

OPERATION AND PARTS MANUAL



MODEL ST3020B1/ST3020BCUL SUBMERSIBLE PUMPS

Revision #2 (10/28/10)



www.discount-equipment.com

THIS MANUAL MUST ACCOMPANY THE EQUIPMENT AT ALL TIMES.

Discount Equipment

Discount-Equipment.com is your online resource for commercial and industrial quality parts and equipment sales.

Locations:

Florida (West Palm Beach): [561-964-4949](tel:561-964-4949)

Outside Florida TOLL FREE: [877-690-3101](tel:877-690-3101)

Need parts? Check out our website at www.discount-equipment.com

Can't find what you need?

Click on this link: <http://www.discount-equipment.com/category/5443-parts/> and fill out the request form.

Please have the machine model and serial number available in order to help us get you the correct parts. One of our experienced staff members will get back to you with a quote for the right part that your machine needs.

We sell worldwide for the brands: Genie, Terex, JLG, MultiQuip, Mayco, Toro/Stone, Diamond Products, Magnum, Airman, Mustang, Power Blanket, Nifty Lift, Atlas Copco, Chicago Pneumatic, Allmand Brothers, Essick, Miller Spreader, Skyjack, Lull, Skytrak, Tsurumi, Husquvarna/Target, Whiteman-Concrete/Mortar, Stow-Concrete/Mortar, Baldor, Wacker, Sakai, Snorkel, Upright, Mi-T-M, Sullair, Neal, Basic, Dynapac, MBW, Weber, Bartell, Bennar Newman, Haulotte, Ditch Runner, Blaw-Knox, Himoina, Best, Buddy, Crown, Edco, Wyco, Bomag, Laymor, Terremite, Barreto, EZ Trench, Takeuchi, Basic, Bil-Jax, Curtis, Gehl, Heli, Honda, ICS/PowerGrit, Puckett, Waldon, ASV, IHI, Partner, Imer, Clipper, MMD, Koshin, Rice, Gorman Rupp, CH&E, Cat Pumps, Comet, General Pump, Giant, AMida, Coleman, NAC, Gradall, Square Shooter, Kent, Stanley, Tamco, Toku, Hatz, Kohler, Robin, Wisconsin, Northrock, Oztec, Toker TK, Rol-Air, Small Line, Wanco, Yanmar

New Equipment - Used Equipment - Rental Equipment - Parts and Accessories

Discount Equipment

www.discount-equipment.com

561-964-4949

Sales: info@Discount-Equipment.com

Parts: wbparts@Discount-Equipment.com

TABLE OF CONTENTS

Multiquip ST3020B1/BCUL Submersible Pump

Table Of Contents.....	2
Parts Ordering Procedures.....	3
Safety Information	4-7
Dimensions.....	8
Specifications	9
Performance Curve.....	10
General Information.....	11
Components	12
Direct Power Operation	13
Float Switches	14-15
Float Switches (CB6 Control Box)	16
Float Switches (CB200 Control Box Old Style)	17
Float Switches (CB200 Control Box New Style).....	18
Operation.....	19-24
Maintenance	24-26
Troubleshooting	27
CB6 Wiring Diagram.....	28
CB200 Wiring Diagram.....	29
Explanation of Code in Remarks Column.....	30
Suggested Spare Parts	31

Component Drawings

Pump Assembly.....	32-33
Motor Assembly.....	34-35
Terms And Conditions Of Sale — Parts	36

NOTICE

Specifications and part numbers are subject to change without notice.

SAFETY INFORMATION

Do not operate or service the equipment before reading the entire manual. Safety precautions should be followed at all times when operating this equipment. Failure to read and understand the safety messages and operating instructions could result in injury to yourself and others.



SAFETY MESSAGES

The four safety messages shown below will inform you about potential hazards that could injure you or others. The safety messages specifically address the level of exposure to the operator and are preceded by one of four words: **DANGER**, **WARNING**, **CAUTION** or **NOTICE**.

SAFETY SYMBOLS

DANGER
Indicates a hazardous situation which, if not avoided, WILL result in DEATH or SERIOUS INJURY .
WARNING
Indicates a hazardous situation which, if not avoided, COULD result in DEATH or SERIOUS INJURY .
CAUTION
Indicates a hazardous situation which, if not avoided, COULD result in MINOR or MODERATE INJURY .
NOTICE
Addresses practices not related to personal injury.

Potential hazards associated with the operation of this equipment will be referenced with hazard symbols which may appear throughout this manual in conjunction with safety messages.

Symbol	Safety Hazard
	Burn hazards
	Electric shock hazards
	Rotating parts hazards
	Pressurized fluid hazards

SAFETY INFORMATION

GENERAL SAFETY

CAUTION

- **NEVER** operate this equipment without proper protective clothing, shatterproof glasses, respiratory protection, hearing protection, steel-toed boots and other protective devices required by the job or city and state regulations.



- Avoid wearing jewelry or loose fitting clothes that may snag on the controls or moving parts as this can cause serious injury.

- **NEVER** operate this equipment when not feeling well due to fatigue, illness or when under medication.



- **NEVER** operate this equipment under the influence of drugs or alcohol.



- **ALWAYS** clear the work area of any debris, tools, etc. that would constitute a hazard while the equipment is in operation.

- No one other than the operator is to be in the working area when the equipment is in operation.

- **DO NOT** use the equipment for any purpose other than its intended purposes or applications.

NOTICE

- This equipment should only be operated by trained and qualified personnel 18 years of age and older.

- Whenever necessary, replace nameplate, operation and safety decals when they become difficult read.

- Manufacturer does not assume responsibility for any accident due to equipment modifications. Unauthorized equipment modification will void all warranties.

- **NEVER** use accessories or attachments that are not recommended by Multiquip for this equipment. Damage to the equipment and/or injury to user may result.

- **ALWAYS** know the location of the nearest fire extinguisher.



- **ALWAYS** know the location of the nearest first aid kit.



- **ALWAYS** know the location of the nearest phone or **keep a phone on the job site**. Also, know the phone numbers of the nearest **ambulance, doctor and fire department**. This information will be invaluable in the case of an emergency.



SAFETY INFORMATION

PUMP SAFETY

DANGER

- **NEVER** operate the equipment in an explosive atmosphere or near combustible materials. An explosion or fire could result causing severe **bodily harm or even death.**



WARNING

- Accidental starting can cause severe injury or death. **ALWAYS** place the ON/OFF switch in the OFF position.
- **DO NOT** place hands or fingers inside pump when pump is running.
- **NEVER** disconnect any **emergency or safety devices.** These devices are intended for operator safety. Disconnection of these devices can cause severe injury, bodily harm or even death. Disconnection of any of these devices will void all warranties.
- Risk of Electric Shock - This pump has not been investigated for use in swimming pool or marine areas.



CAUTION

- **DO NOT** restrict the flow of the discharge hose as it may cause the pump to overheat.
- Be careful of discharge hose whipping under pressure.
- **ALWAYS** check pump oil level only when pump is cool. Expansion due to heat may cause hot oil to spray from the oil plug when the oil plug is removed. The possibility of severe scalding may exist.

NOTICE

- **ALWAYS** place the pump in an upright position on a platform before using. The platform will prevent the pump from burrowing itself on soft sand or mud.
- **NEVER** operate pump on its side.
- **DO NOT** allow the pump to freeze in water.
- **NEVER** leave an open pump chamber unattended.
- **ALWAYS** keep the machine in proper running condition.
- **DO NOT** attempt to thaw out a frozen pump by using

a torch or other source of flame. Application of heat in this manner may heat the oil in the seal cavity above the critical point, causing pump damage.

- **DO NOT** pump water with a temperature greater than 104°F.
- **DO NOT** pump liquids containing acid or alkali.
- **ALWAYS** check strainer before pumping. Make sure strainer is not clogged. Remove any large objects, dirt or debris from the strainer to prevent clogging.
- **ALWAYS** use a large basket strainer when pumping water that contains large debris.
- **ALWAYS** flush pump (clean) after use when pumping water concentrated with heavy debris. It is very important to always flush the pump before turning it off to prevent clogging.
- Fix damage to machine and replace any broken parts immediately.
- **ALWAYS** store equipment properly when it is not being used. Equipment should be stored in a clean, dry location out of the reach of children and unauthorized personnel.
- **NEVER** lubricate components or attempt service on a running machine.
- **NEVER** run pump *dry*.
- **ALWAYS** allow the machine a proper amount of time to cool before servicing.
- Keep machine in proper running condition.

ELECTRICAL SAFETY

DANGER

- The electrical voltage required to operate pump can cause severe injury or even death through physical contact with live circuits. **ALWAYS** disconnect electrical power from pump before performing maintenance on pump.



WARNING

- To reduce the risk of electric shock, connect only to a circuit protected by a Ground-Fault Circuit-Interrupter (GFCI).

SAFETY INFORMATION

NOTICE

- **ALWAYS** make certain that the voltage supplied to the pump is correct. Always read the pump's nameplate to determine what the power requirements are.

Power Cord/Cable Safety

⚠ DANGER

- **NEVER** let power cords or cables lay in water.
- **NEVER** stand in water while AC power cord is connected to a live power source.
- **NEVER** use **damaged** or **worn** cables or cords. Inspect for cuts in the insulation.
- **NEVER** grab or touch a live power cord or cable with wet hands. The possibility exists of **electrical shock, electrocution or death.**
- Make sure power cables are securely connected to the motor's output receptacles. Incorrect connections may cause electrical shock and damage to the motor.

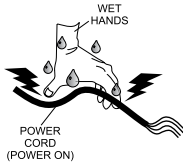

⚠ WARNING

- **NEVER** attempt to use the power cord as a lifting or lowering device for the pump.

NOTICE

- **ALWAYS** make certain that proper power or extension cord has been selected for the job. See Cable Selection Chart in this manual.

Grounding Safety

⚠ DANGER

- **ALWAYS** make sure pump is grounded.
- **NEVER** use gas piping as an electrical ground.
- **ALWAYS** make sure that electrical circuits are properly grounded to a suitable earth ground (ground rod) per the National Electrical Code (NEC) and local codes before operating generator. **Severe injury or death by electrocution** can result from operating an ungrounded motor.

Control Box Safety

⚠ DANGER

- **ALWAYS** have a qualified electrician perform the control box installation. The possibility exists of electrical shock or electrocution.

NOTICE

- **ALWAYS** mount control box in a vertical position protected from harsh environmental elements.

LIFTING SAFETY

⚠ CAUTION

- When raising or lowering of the pump is required, always attach an adequate rope or lifting device to the correct lifting point (handle) on the pump.

NOTICE

- **DO NOT** lift machine to unnecessary heights.
- **NEVER** lift the equipment while the electric motor is running.

TRANSPORTING SAFETY

NOTICE

- **ALWAYS** shut down pump before transporting.
- **ALWAYS** tie down equipment during transport by securing the equipment with rope.

ENVIRONMENTAL SAFETY/DECOMMISSIONING

- **DO NOT** pour waste or oil directly onto the ground, down a drain or into any water source.
- Contact your country's Department of Public Works or recycling agency in your area and arrange for proper disposal of any electrical components, waste or oil associated with this equipment.
- When the life cycle of this equipment is over it is recommended that the pump casing and all other metal parts be sent to a recycling center



Metal recycling involves the collection of metal from discarded products and its transformation into raw materials to use in manufacturing a new product.

Recyclers and manufacturers alike promote the process of recycling metal. Using a metal recycling center promotes energy cost savings.

DIMENSIONS

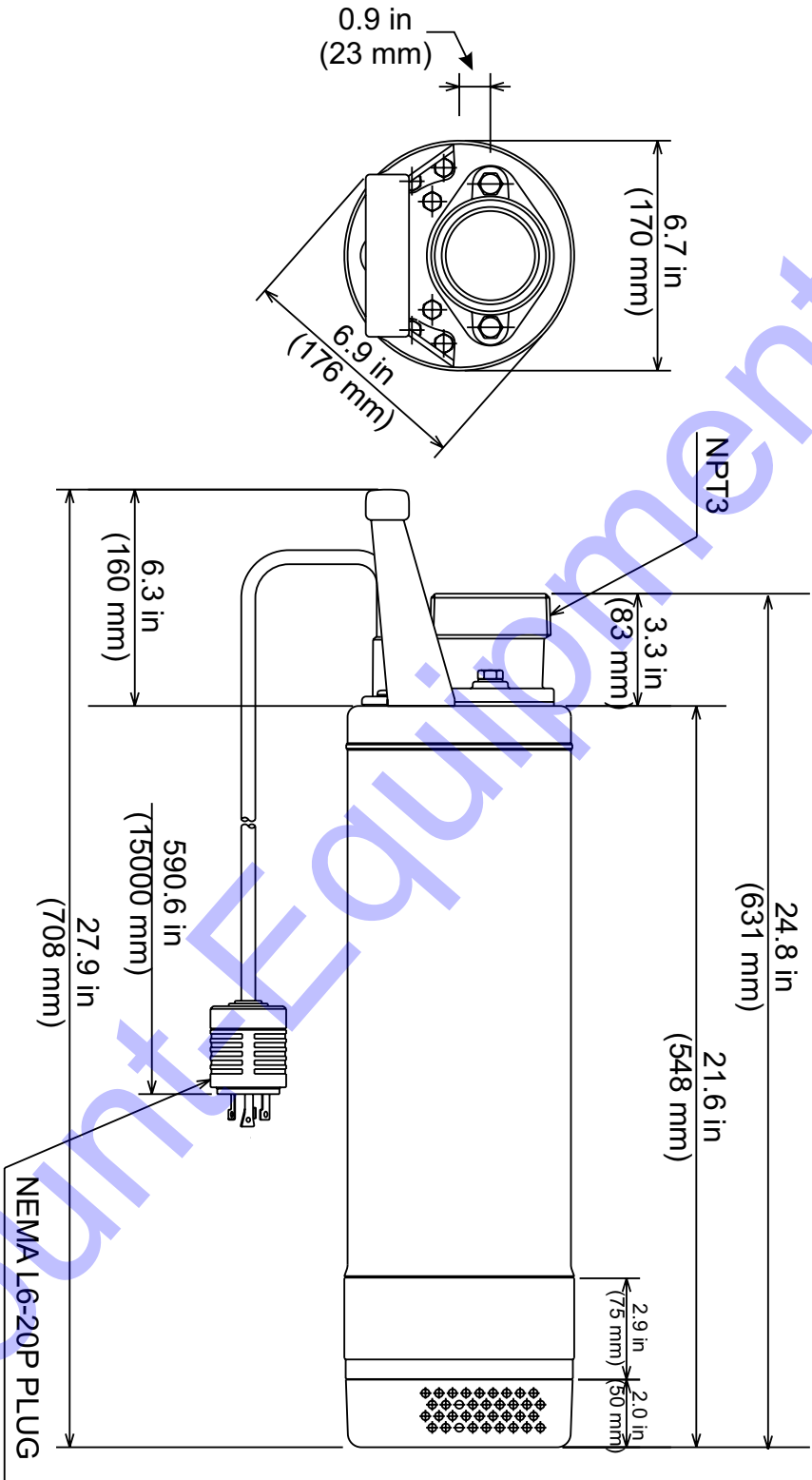

Figure 1. ST3020B1/BCUL Pump Dimensions

SPECIFICATIONS

Table 1. Specifications	
Model	ST3020B1/BCUL
Type	Centrifugal Submersible Pump
Impeller	Cast Ductile Iron
Suction & Discharge Size	3 in. (76 mm)
Maximum Pumping Capacity	145 gallons/minute (548 liters/minute)
Max Head	66 ft. (20.1 meters)
Power	2 HP (1.5 kW)
Voltage Phase	1Ø 230 V
Starting Amps	52.2 A
Running Amps	10.5 A
Control Box Required	See Note 3
Temperature Range	32°F ~ 86°F (0°C ~ 30°C)
Thermal Overload Protection	YES
Rotation	CCW (See Note 1)
Mechanical Seal Oil Capacity	18 in ³ (300 cc) (See Note 2)
Power Cable Length	50 ft (approx. 15 m)
Dry Net weight	67 lb (31 kg)

1. **Motor Rotation** – Upon start-up, the pump **"kicks"** in the opposite direction of motor rotation. The correct rotation is counterclockwise (CCW) as viewed from the impeller end of the pump.
2. **Mechanical Seal Oil** – Use ISO VG32 oil grade. Fill oil cavity 75% to 85% full (allow air space for expansion).
3. **Control Box** - Control box (Table 2) may be required for certain pumping applications.

Table 2. Control Box Specifications				
Model	Voltage Type	UL/CSA Listed	Thermal Overload Protection	Float Switch Capability
CB6	230 VAC, 60 Hz Single Phase	YES	NO	YES
CB200	230 VAC, 60 Hz Single Phase	YES	YES	YES

PERFORMANCE CURVE

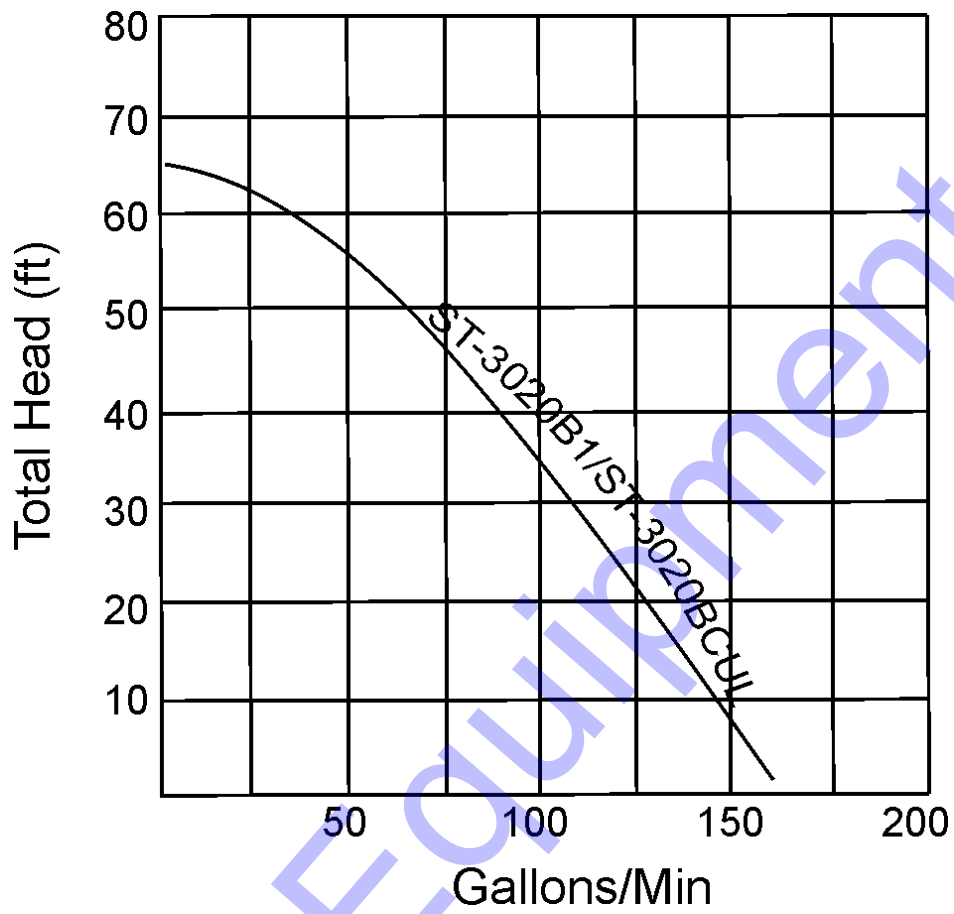

Figure 2. Pump Performance Curve

GENERAL INFORMATION

The Multiquip Model ST3020B1 and ST3020BCUL submersible pumps are designed to pump water and is used for the draining (dewatering) of well casings construction sites, coffer dams, manholes, transformer vaults and excavations.

It's slim design (only 6.7 inches in diameter) allows it to fit easily inside 8-inch casings and eliminates the need for larger, more costly casings. The pump is powered by a 2-HP, 230-volt, single-phase motor for easy starting with a 6,000-watt generator.

This rugged submersible pump is loaded with features such as:

- **THERMAL OVERLOAD PROTECTION** - automatically shuts off the motor should it reach an unsafe operating temperature.
- **HEAVY-DUTY LIFTING HANDLE** - provides and convenient and safe location to attach a lifting device.
- **STRAIN-RELIEF PROTECTOR** - provides added safety in the event the operator should try lifting the pump from the electrical cord.
- **REPLACEABLE DISCHARGE PORT** - provides easy maintenance and lower repair costs.
- **DOUBLE OIL-LUBRICATED SEAL** - provides positive lubrication if the pump should be left running dry. This helps prevent damage in the event the pump is run dry for short periods of time.
- **DUCTILE IRON IMPELLER** - for abrasion resistance and extended life. The high-chrome ductile iron material minimizes wear.
- **CORROSION-RESISTANT STAINLESS-STEEL SHAFT** - simplifies maintenance

If the pump was used to pump water containing mud, silt, use clean water to flush out the pump after each use.

DO NOT allow the pump to run dry for an extended period of time, as this will damage the pump. During maintenance, dry running is permissible but only for a few seconds.

NEVER lift the pump by its electrical power cord. **ALWAYS** lift the pump by its carrying handle or attach a rope to the carrying handle.

A pump fully submerged in liquid will not freeze, unless the liquid freezes. **DO NOT** allow a partially submerged pump to freeze. The expansion of water freezing in the volute may crack the pump, causing expensive repairs. If there is any danger of the pump being subjected to freezing temperatures, Lift the pump from water and allow it to drain thoroughly.

If the pump jams or the pump rotor locks for any reason, disconnect the pump from the power source immediately. Allowing the pump motor to cycle **ON** and **OFF** under an overload condition can burn out the motor.

When replacement of nuts and bolts is required, use only recommended parts as referenced in the parts section of this manual. This pump uses metric threads. **DO NOT** use English measurement threads.

COMPONENTS

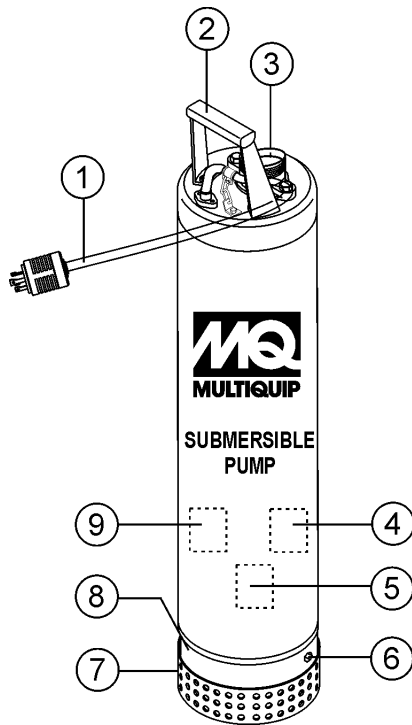

Figure 3. Submersible Pump Components

Figure 3 shows the location of the basic components, for the ST3020B1/BCUL submersible pump. Listed below is a brief explanation of each component.

1. **AC Power Cable** – This unit is supplied with a 50-ft. (approximately 15 meters) AC power cable with a NEMA L6-20P grounding-type plug. Always check the cable for signs of wear. **NEVER** use a defective power cable.
2. **Carrying Handle** – Always carry the submersible pump by its handle. **NEVER** carry the pump by its power cord. Carrying or lifting the pump by the power cord will cause undue stress on the cord and can ultimately dislodge the cord from the pump.
3. **Discharge Port** – Connect a 3-inch hose to this port. Remember to adequately support the discharge hose to avoid stress on the pump.
4. **Thermal Overload Protection** – This pump is equipped with a thermal overload protection device that will shut down the motor in the event of high operating temperatures. The motor will automatically restart once the temperature returns to an acceptable operating temperature.

5. **Mechanical Seal** – The hydraulic oil in the pump cavity is designed to provide cooling for the pump seal. This allows the pump to run dry for a limited period of time.
6. **Mechanical Seal Oil Plug** – Remove this plug to check and add lubrication oil (ISO VG32 grade) to the oil cavity. This oil protects the mechanical seal. Oil cavity should be full enough to cover seal spring.
7. **Strainer Base** – This strainer base is made of electro-coated steel which is resistant to hardware corrosion. **DO NOT** pump large objects or debris with this pump. This pump is for pumping water only. For dewatering purposes, always place the strainer base on a platform.
8. **Volute/Impeller** – Impellers are constructed of ductile iron to minimize wear and prolong service life.
9. **Electric Motor** – These submersible pumps utilize a 60 Hz, single-phase, 230 VAC, 2 HP electric motor. Consult with a licensed electrician before connecting motor to a power source and control boxes. Observe all city and local safety codes.

DIRECT POWER OPERATION

Direct Power Operation

The ST3020B1/BCUL submersible pumps can be configured to operate by direct power (Figure 4) or connected to a control box (Figures 9, 10 and 11) utilizing float switches. When the pump is connected directly to a 1Ø, 230 VAC, 60 Hz power source via the L6-20P plug located at the end of the power cord, the pump will operate soon as power is applied. It is suggested that a quick disconnect switch be installed as a means of turning the power on and off.

When operating the pump using direct power (no control box) the pump must be monitored at all times. Failure to monitor the pump during operation could lead to **severe pump damage** should the pump encounter problems such as a stuck impeller or not fully immersed in water.

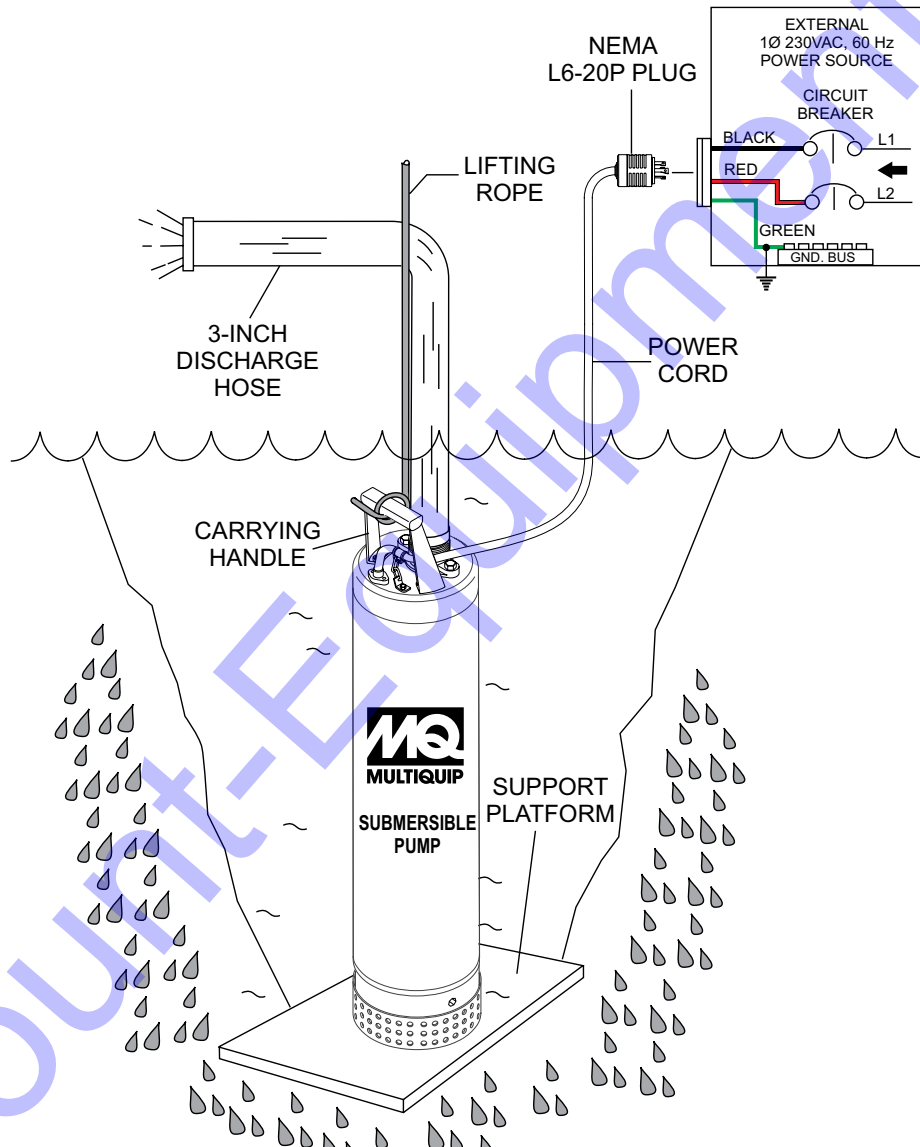

Figure 4. Direct Power Application.

FLOAT SWITCHES

Mechanical Float Switch

Mechanically activated float switches offer a reliable low current control for dewatering applications.

How It Works

The mechanical float switch control will turn ON (close) when the float tips 45° above -horizontal, indicating a high level, and turns OFF (open) when the float switch drops 45° below horizontal. Reference Figure 6 and Figure 7. Maximum pumping range is 120 degrees. See Figure 5 below.

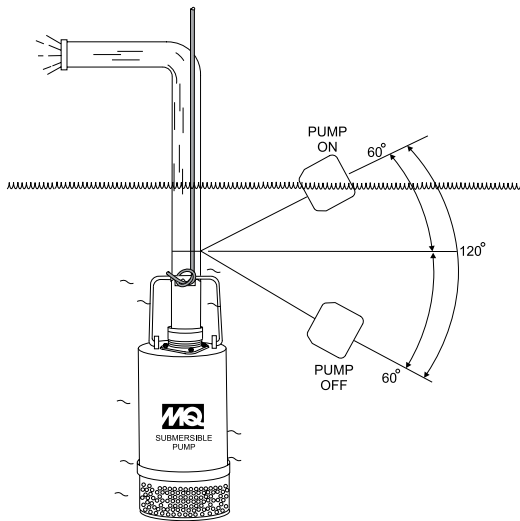

Figure 5. Pumping Range (Float Switch)

Pumping Range

The pumping range of the pump is determined by the float switch tether cord. Use Table 3 as guide line to determine your required pumping range. Pumping ranges are based on non-turbulent conditions. Range may vary due to water temperature and cord shape. Please note as the tether length increases, so does the variance of the pumping range.

Design Features

Float switch housings are constructed of high-impact, corrosion resistant polypropylene with mechanically activated, snap action contacts.

- Suitable for most liquid environments.
- Hermetically sealed.
- Thick-walled non-corrosive PVC plastic enclosure.
- Pressure tested to 30 ft. (9 meters).
- Standard SJO, 16-gauge, 2 conductor cord (20 ft./6.09 m).

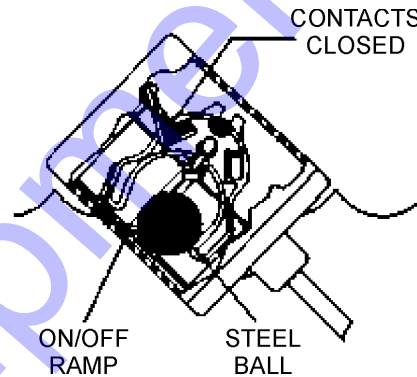

Figure 6. Float Switch (Closed)

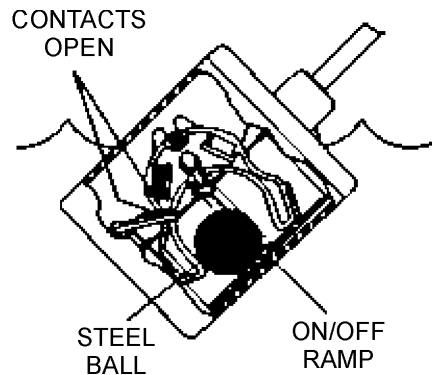

Figure 7. Float Switch (Open)

Table 3. Pumping Range

Tether Length	2 in. 5.08 cm.	4 in. 10.16 cm.	6 in. 15.24 cm.	8 in. 20.32 cm.	10 in. 25.4 cm.	12 in. 30.48 cm.	14 in. 35.56 cm.	16 in. 40.46 cm.
Pumping Range	6 in. 15.24 cm.	10 in. 25.4 cm.	14 in. 35.56 cm.	18 in. 45.72 cm.	22 in. 55.88 cm.	27 in. 68.58 cm.	31 in. 78.74 cm.	35 in. 88.9 cm.

Float Switches

For unattended operation of the submersible pump **two** Model SW1WOPA float switches will be required. These float switches have bare wires on one end of the cable for direct connection to either the CB6 or CB200 Control Boxes. The illustration below is an example of using two single float switches in a typical dewatering application.

Mounting The Float Switches

1. Determine the required **cord tether length** as shown in Figure 5 and Table 3.
2. Place the cord into the clamp as shown in Figure 8.
3. Secure the clamp to the discharge hose as shown in Figure 8. **DO NOT** install cord under hose clamp.
4. Using a screwdriver, tighten the hose clamp. **DO NOT** over-tighten. Make sure the float cord is not allowed to touch the excess hose clamp band during operation.

NOTICE

Single float switch, Model SW1A has a pumping range between 5.5~18 in. (14~46 cm.). Dual float switch has a pumping range between 1~48 in. (2.54~122 cm.)

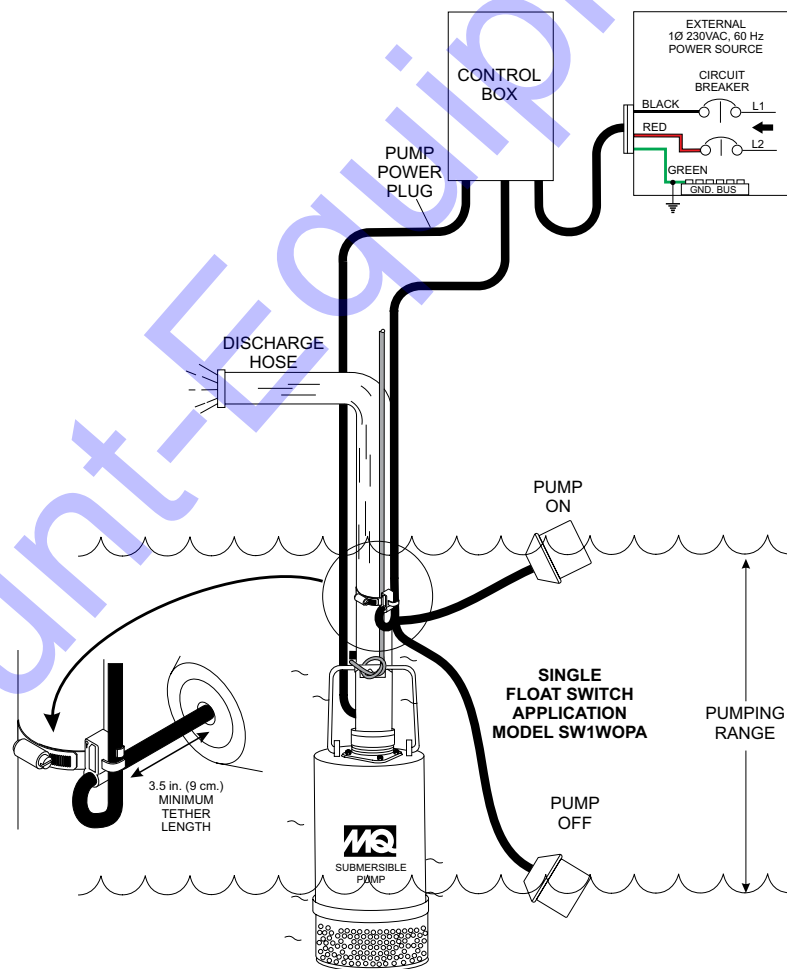

Figure 8. Single Float Switch (2) Application Diagram

FLOAT SWITCHES (CONTROL BOX)

Control Boxes (CB6 and CB200)

For special remote pumping applications of the submersible pump, a control box (Models CB6 or CB200) is required. These water resistant control boxes provides watertight housing and glands to prevent water from leaking into the box, and a float switch interface. Both control boxes will require the use of **two** SW-1WOPA float switches, no plug, bare wires for direct connection to the control box. See Figures 9, 10 and 11 for control box connections.

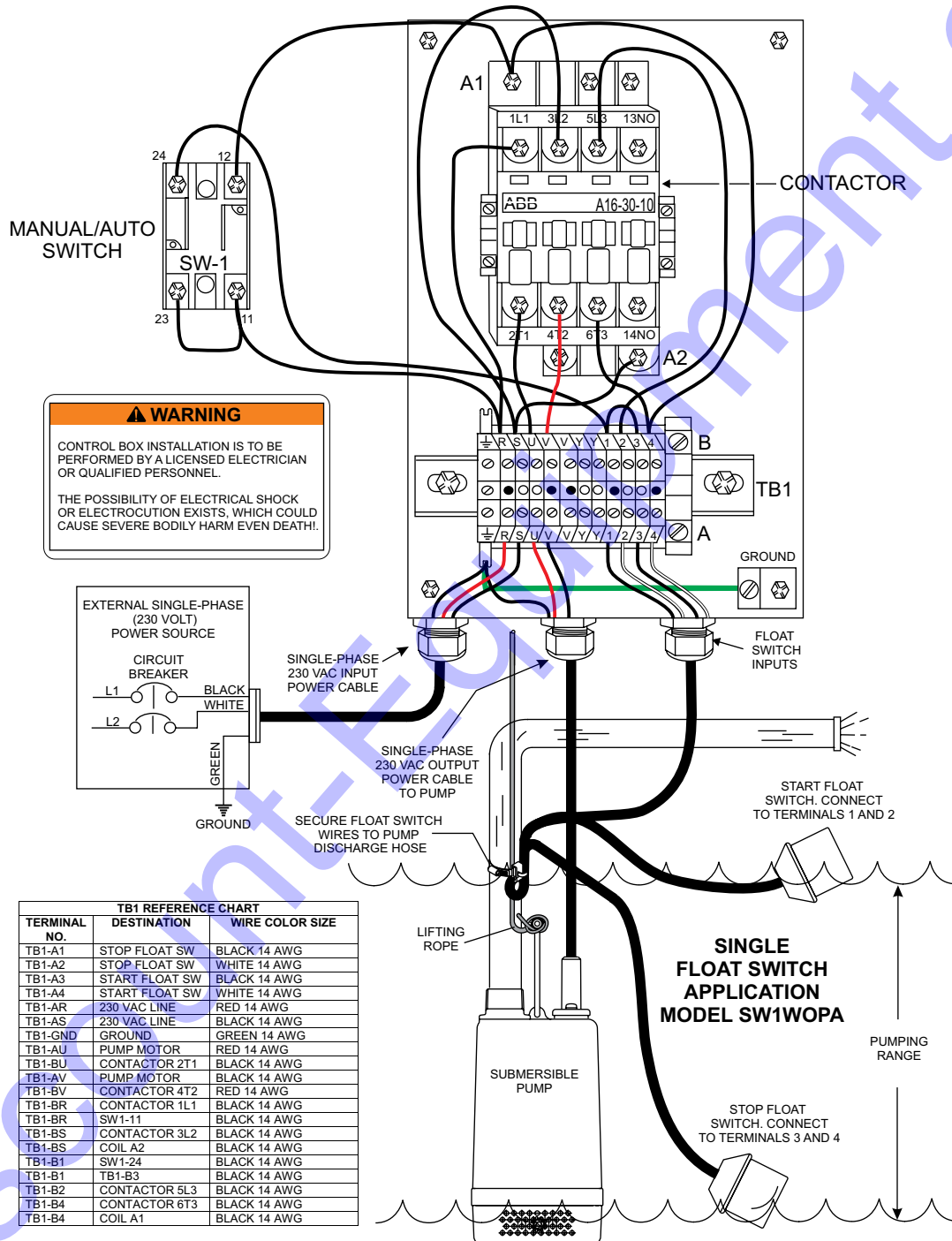
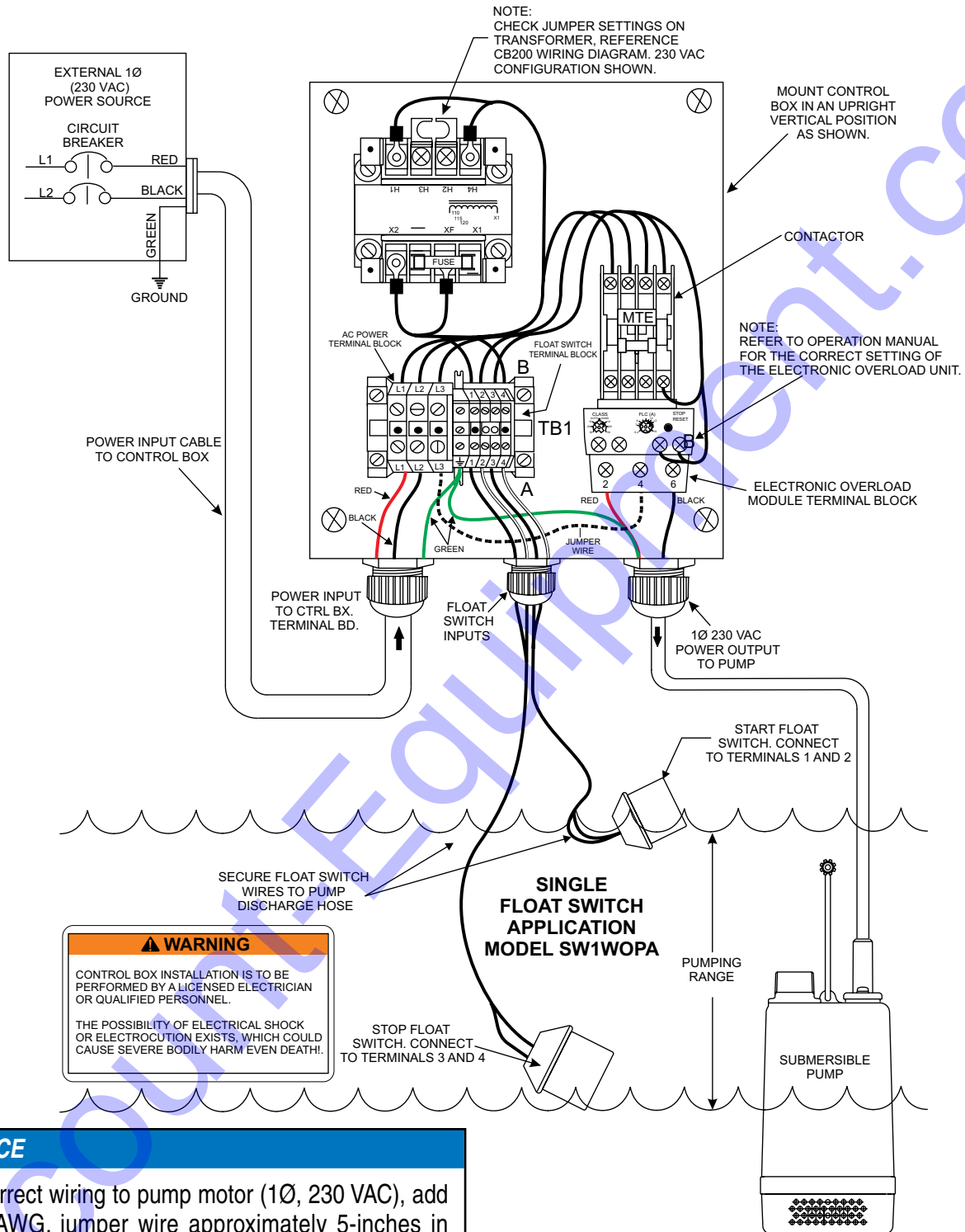

Figure 9. CB6 Control Box Dual Float Switch Application Diagram

FLOAT SWITCHES (CONTROL BOX)



**Figure 10. CB200 Control Box (Old Style)
Dual Float Switch Application Diagram**

FLOAT SWITCHES (CONTROL BOX)

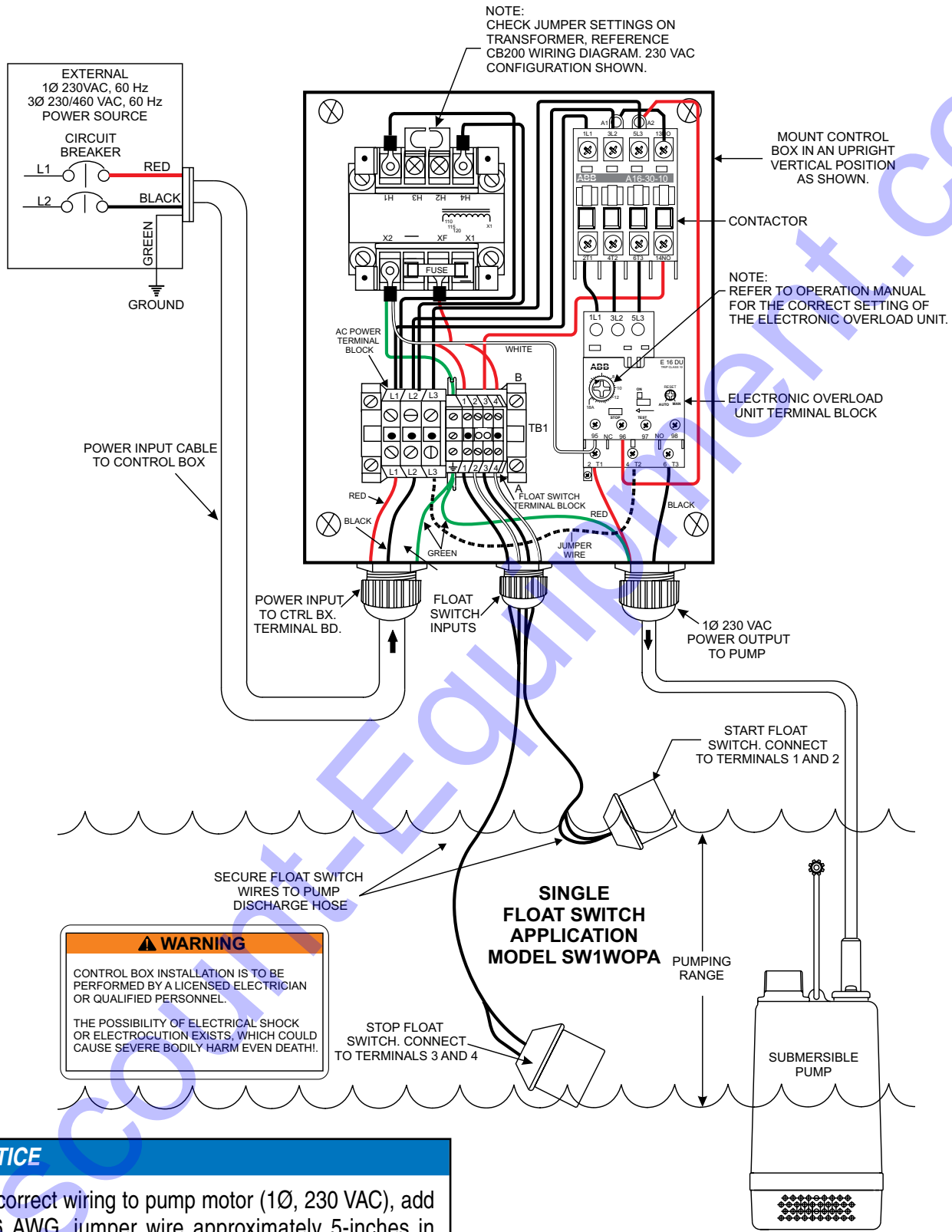

WARNING

CONTROL BOX INSTALLATION IS TO BE PERFORMED BY A LICENSED ELECTRICIAN OR QUALIFIED PERSONNEL.

THE POSSIBILITY OF ELECTRICAL SHOCK OR ELECTROCUTION EXISTS, WHICH COULD CAUSE SEVERE BODILY HARM EVEN DEATH!

NOTICE

For correct wiring to pump motor (1Ø, 230 VAC), add a 16 AWG. jumper wire approximately 5-inches in length between the input terminal block marked L3 and terminal 4 on the electronic overload unit. Reference CB200 wiring diagram (new style)

Figure 11. CB200 Control Box (New Style) Dual Float Switch Application Diagram

Hose Connections

1. Connect a 3-inch hose to the discharge port on the pump as shown in Figure 8. Make sure that hose is attached correctly to the discharge port.

Attaching Lifting Rope

1. Attach a suitable lifting cable (rope) to the carrying handle (Figure 12) on the pump and lower the pump into place. For applications where there is an excessive amount of mud, grit or silt, the use of a support platform is desirable. When pumping water from swimming pool type applications where there is little or no debris, the support platform is not required.

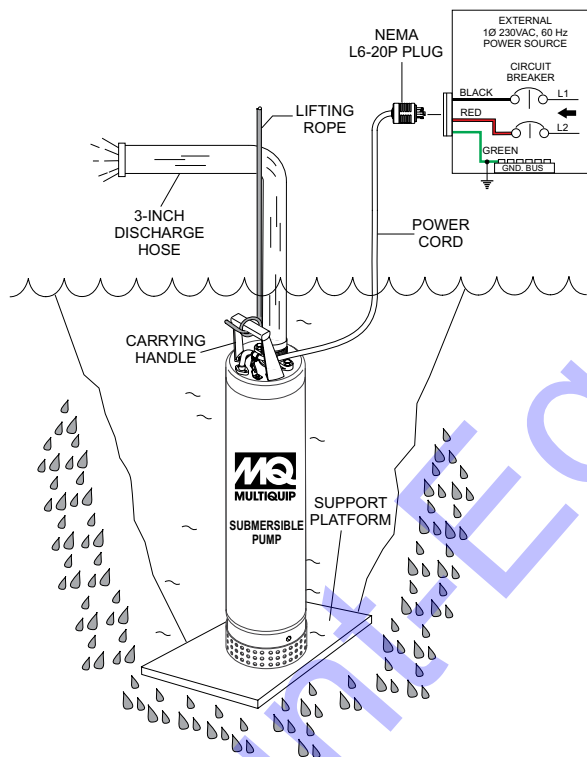

Figure 12. Submersible Pump Upright Position (Correct)

2. Make sure the pump is always placed in an upright position (Figure 12), and not tilted (Figure 13). Never position the pump directly on a soft, loose bottom. Remember to attain maximum pumping capacity and prevent excessive wear. Position the pump so it will not burrow itself into sand or clay.

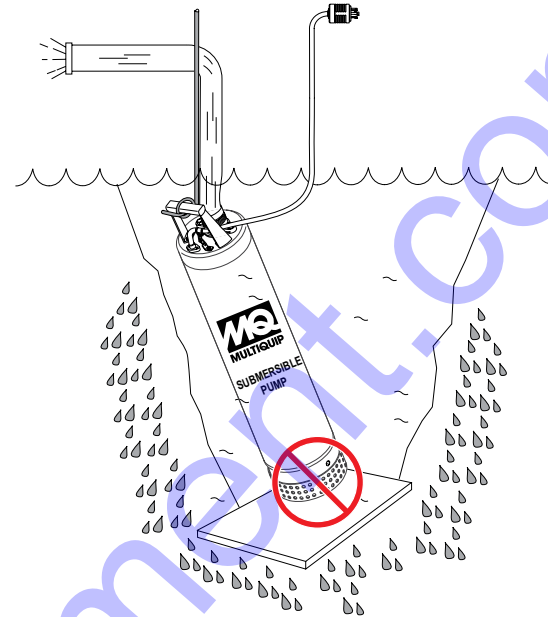

Figure 13. Submersible Pump Tilted Position (Incorrect)

Pump Power Connections (No Control Box)

1. Make sure circuit breaker supplying power to pump motor is in the **OFF** position.
2. Insert the L6-20P power cable plug (Figure 12) into the appropriate power source receptacle. The correct source voltage for this pump is 230 VAC, 60 Hz, single-phase.
3. If all of the pump's electrical requirements have been met, place the circuit breaker or power ON/OFF switch in the **ON** position.
4. Wait a few seconds and water should begin to flow from the discharge hose.
5. If water is not flowing from the discharge hose or not flowing freely after a few minutes, place the circuit breaker or ON/OFF switch in the **OFF** position and check the system for leaks.

NOTICE

When connecting the pump directly to a power source (no control box), it is recommended that personnel monitor the pump while in operation. Severe pump damage can occur if left unattended.

For unattended operation Multiquip recommends the use of either the CB6 or CB200 control box.

Control Box Installation

The following procedure outlines the steps for connecting the pump to a control box.

⚠ DANGER



The ST3020B1 and SB3020BCUL submersible pumps are also designed to work with a control box. This control box contains the necessary electronics (float switch connections) to operate the pump. Remember this control box contains hazardous voltages. Disconnect all sources of power before installing or servicing. There exists the possibility of electrocution, electric shock or burn, which can cause severe bodily harm or even **death!**

⚠ DANGER



When installing the control box, the possibility exists of electrical shock, electrocution and possibly death! **NEVER** have untrained personnel perform the installation. **ALWAYS** have qualified service personnel (licensed electrician) perform the installation.

⚠ WARNING



Explosion or Fire Hazard exists if this pump is used with flammable liquids. **DO NOT** use this pump with **flammable liquids**. **DO NOT** install this pump in hazardous locations as defined by the National Electrical Code, ANSI/NFPA 70.

Control Box Mounting

Mount the control box in an **upright vertical position**. Make sure the control box is securely fastened to a flat surface, that is free of dust, dirt, moisture or any elements that may contaminate or erode the electronic components of the control box.

Single-Phase Power Installation (Input)

The ST3020B1/BCUL submersible pump requires 1Ø, 230 VAC, 60 Hz, power for normal operation.

If you cannot determine what your pump's power requirements are, look at the vendor supplied identification name tag attached to the pump or contact Multiquip's service department.

NOTICE

Applying incorrect power (voltage or voltage phase) to the submersible pump can cause severe damage to the pump motor. Please make sure that the correct voltage and phase are connected to the pump motor at all times.

Power Cord Requirements

When routing the 230 VAC, 60 Hz., single phase power via a power cord to the control box, **ALWAYS** use the correct wire size. Please refer to Table 4 to determine the correct wire size. Incorrect wire size can adversely affect the performance of the pump and may ultimately burn-out the pump motor.

Table 4. Power Cord Length and Wire Size			
AMPS	50 FT. (15.24 m)	100 FT. (30.48 m)	150 FT. (45.72 m)
6	16 AWG	16 AWG	14 AWG
8	16 AWG	14 AWG	12 AWG
10	16 AWG	14 AWG	12 AWG
12	14 AWG	14 AWG	12 AWG
14	14 AWG	12 AWG	10 AWG
16	12 AWG	12 AWG	10 AWG

Connecting Dual float Switch (SW-1WOP) To Control Box

1. Remove the float switch input connector housing, then route the float switch wires through the cable gland on the control box. Attach the wires of the float switch to the terminal block as indicated by Table 5 and Figures 7, 8 and 9.

Table 5. Dual Float switch Connections

Float Switch	Terminal Block No.	Wire Color	Control Box
Start	TB1-A1 TB1-A2	Black White	CB6/CB200
Stop	TB1-A3 TB1-A4	Black White	CB6/CB200

2. Tighten the connector housing to ensure a tight fit between the cord and the connector body. This will prevent the cable from pulling out of the terminal block and also prevent moisture from entering the control box.
3. Determine the tether length of the float switch wires then secure float switch wires to pump discharge hose. See Figure 8 and Table 3 to determine the pumping range.

Connecting AC Power to the CB 200 Control Box

1. The AC power cord (input) should have three wires. Each wire is color coded. The colors are **RED, BLACK** and **GREEN**.
2. Remove the AC input connector housing from the control box, then route the power cord through the cable gland on the control box.
3. Connect the AC power cord to the terminal block (TB1) located inside the control box as shown in Figures 9, 10, 11 and Table 6.

Table 6. 1Ø-230 VAC Power Connections

Wire Color	CB6 Terminal Block No.	CB200 Terminal Block No.
BLACK	TB1-AR (L1)	TB1A-L1
RED	TB1-AS (L2)	TB1A-L2
GREEN	TB1-GND	TB1-GND

4. Connect the other end of the AC power cord to the voltage source. Remember to provide a means of disconnecting the power from the control box (circuit breaker or quick disconnect switch). Also make sure to provide a good earth ground to the control box

NOTICE

It is recommended that the power being supplied to the control box **ALWAYS** be connected to a **circuit breaker** or a **quick disconnect switch**. This safety feature allows for quick removal of power from the control box in the event of an emergency.

Connecting AC Power to the Pump Motor

1. AC power is routed to the pump motor via a contactor/thermal overload unit. The coil of the contactor is energized or de-energized by the opening and closing of the float switch contacts. The thermal overload unit protects the windings of the electric motor in the event of a stuck impeller.
2. The power cord should have three wires. Each wire is color coded. The colors are **RED, BLACK** and **GREEN**.
3. Remove the pump AC input connector housing from the control box, then route the power cord through the cable gland on the control box.
4. Connect pump power cord to the thermal overload unit and TB1 as shown in Figures 8, 9 and Table 7.

Table 7. 1Ø-230 VAC Power Connections

Wire Color	CB200 Thermal Overload Unit Terminal Block TB1
BLACK	T1-2 (L1)
RED	T3-6 (L3)
GREEN	TB1-GND

5. Install **jumper wire** between T2 of electronic overload module and TB1-L3. Reference Figures 10 and 11.

NOTICE

CB6 control box does not have thermal overload capability. Install jumper wire (CB200 Control Box) between T2 of electronic overload module and TB1-L3. Jumper wire **must** be installed in order for electronic overload module to work correctly.

Electronic Overload Module Settings

NOTICE

ALWAYS make sure that the electronic overload module supplied with the control box is set to the correct amperage. This overload module must **MATCH** the amperage requirements of the pump motor.

Using an electronic overload unit with incorrect settings may result in serious damage to the pump. **ALWAYS** check the nameplate on the pump to determine the required amperage settings for the overload module.

CB200 Control Box Old Style Electronic Overload Module

There are two dials on the Electronic Overload Module (Figure 14) that require setting before the pump can be used with the control box.

These dials are located on top of the overload module and are labeled CLASS and FLC (A).

Use a phillips-head screw driver to adjust the dials to the correct settings.

Full Load Current (FLC) Amps Dial Setting

1. Set the FLC (A) dial pointer (Figure 14) to 10.5. This setting represents the running amps of the pump. This information can be located on the pump's nameplate.

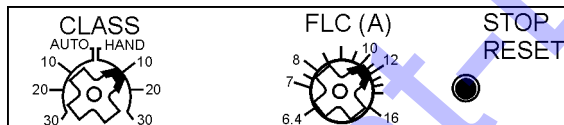

Figure 14. Electronic Overload Module (Old Style)

Class Dial Setting

1. Depending on the application, Set the **CLASS** dial pointer (Figure 14) to either **HAND** (manual) or **AUTO**.
2. There are 3 groups of numbers on the **CLASS** dial that range from 10 to 30. These numbers represent the trip class of the thermal overload device.
3. Set the **CLASS** dial pointer to position 10. This setting controls the reset function only. It does not affect the ability of the pump to run with or without float switches.

Reset Operation

This electronic control unit has two modes of reset. The modes are defined as follows:

MODE 1

When the **CLASS** dial on the electronic overload module is in the **HAND** position (manual) the reset button (Figure 15) on the front of the control box must be pushed to reset the unit (restore power) in the event of an overload.



Figure 15. Control Box Reset Button

MODE 2

When the **CLASS** dial on the electronic overload module is in the **AUTO** position (automatic mode) the unit will automatically be reset in the event of an overload.

NOTICE

The CB200 Control Box (old style) is shipped from the factory with the **CLASS** dial set to the **HAND** position.

CB200 Control Box New Style Electronic Overload Module

There are two dials (A and B) on the Electronic Overload Module (Figure 16) that require setting before the pump can be used with the control box.

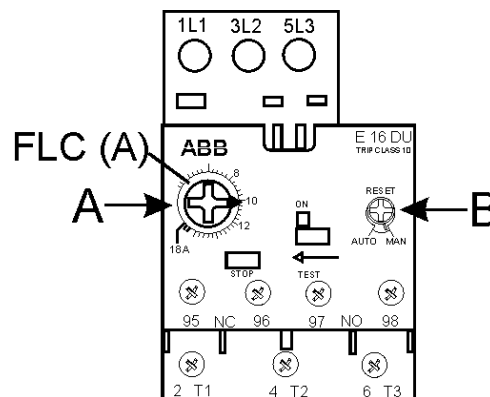

Figure 16. Electronic Overload Module (New Style)

Full Load Current (FLC) Amps Dial A Setting

1. Set dial **A** pointer (Figure 16) to 10.5. This setting represents the running amps of the pump. This information can be located on the pump's nameplate

Reset Dial Setting

1. Depending on the application, Set **RESET** dial **B** pointer (Figure 16) to either **AUTO** or **MAN**.

Manual Operation

1. From the voltage source set the circuit breaker or quick disconnect switch to the **ON** position.
2. For manual operation of the pump, place the 3-position operation switch (Figure 17) on the control box in the **MANUAL** position.

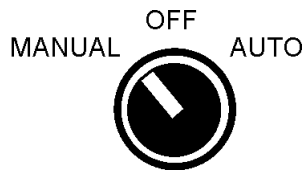

Figure 17. Manual-Off-On SW. (Man Position)

3. Verify that the **ON** indicator (Figure 18) on the control box is LIT. This means that power is being supplied to the control box.



Figure 18. Control Box Power ON Indicator

4. In the manual mode the pump will run continuously. Pay close attention when running the pump in this mode. Severe **DAMAGE** to the pump may occur if pump is not immersed in water.

Automatic Operation

1. From the voltage source set the circuit breaker or quick disconnect switch to the **ON** position.
2. Make sure float switches have been connected to the control box. References Figures 9,10 and 11.
3. For automatic operation of the pump, place the 3-position operation switch (Figure 19) on the control box in the **AUTO** position.

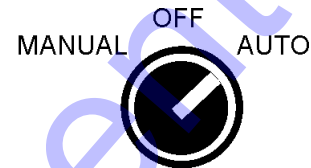

Figure 19. Manual-Off-On SW. (AUTO Position)

4. In the **AUTO** mode the pump will run as long as there is a sufficient amount of water for the **start float** switch to be activated. This water level is determined by the setting of the float switches.

The **stop float** switch contacts will open when the water level is low and power will be removed from the pump's motor.

5. Once the water level has risen back to the appropriate level the **start float** switch contacts will close and power will be restored to the pump's motor.

OPERATION/MAINTENANCE

Shut-Down

1. Place the 3-position operation switch on the control box in the **OFF** position (Figure 20).

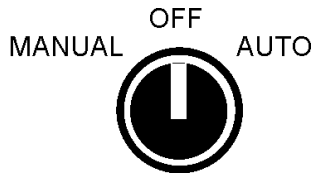

Figure 20. Manual-Off-On SW. (OFF Position)

2. Verify that the control box power ON light is **OFF**.
3. Remove the power from the pump by turning off the circuit breaker or switch that provides power to the pump. Remember to make sure that hands are dry (not wet), and feet are not standing in water when removing or disconnecting power from the pump.
4. Using the lifting rope, lift the pump up from its current position. Remove the discharge hose from the discharge port on the pump.
5. Remove all power cables and float switches from the control box. Place cables and float switches in a suitable container where they will not get damaged.

Cleanup

1. Wipe off any mud or debris that might have attached itself to the pump.
2. If the pump was used to pump mud, grit or silt, flush vigorously with clean water.
3. Store pump in a clean dry place away from dirt and debris.

Lubrication

To check the lubrication oil level of the mechanical seal perform the following:

Checking Lubrication Oil Level

1. Lay the pump (Figure 21) on its side with the oil plug facing upwards.
2. Using an allen wrench, remove oil fill plug.
3. Visually inspect oil plug hole to verify that oil cavity is full enough to cover seal spring.
4. When reinstalling oil fill plug, apply teflon tape to prevent leaking.

Changing Lubrication Oil

1. If lubrication oil level is low, block the oil fill opening with a finger and roll pump to one side to drain oil into a small container.
2. Use a funnel (Figure 21) and fill oil cavity with ISO VG32 lubrication oil or equivalent. Pump oil cavity capacity is 300 cc. Fill to 75-80% capacity to allow for expansion. Replace lubrication oil every 6 months (1,000 hours) or as needed.

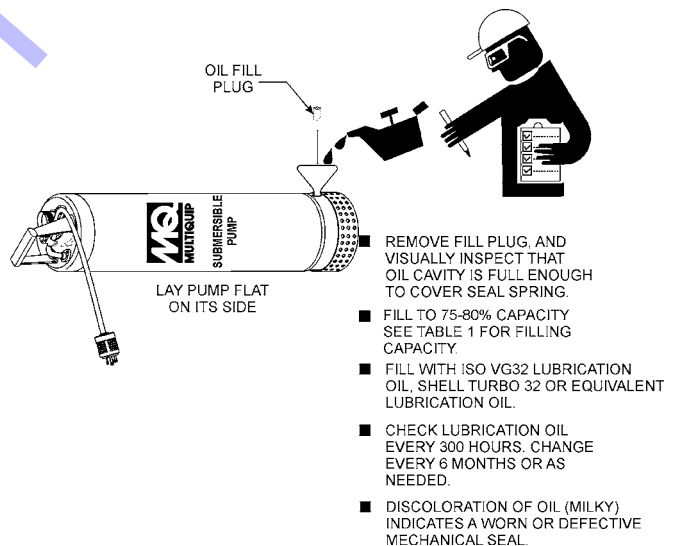

Figure 21. Adding Lubrication Oil

Inspecting Lubrication Oil (Mechanical Seal)

1. Block the oil fill opening with a finger and roll pump to one side to drain (Figure 22) oil into a small transparent container.
2. If oil is cloudy (milky) or has water in it, indicates that mechanical seal is defective or worn. Replace **mechanical seal**.

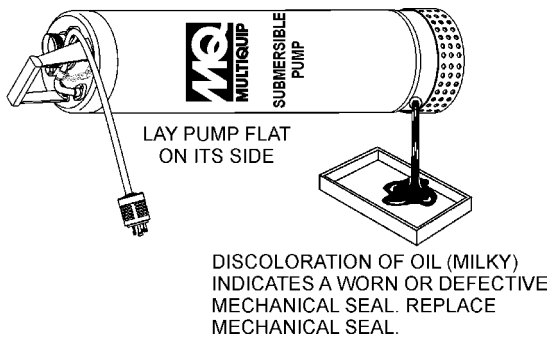

Figure 22. Lubrication Oil Inspection

Impeller/Mechanical Seal Replacement

Refer to the the following procedure and Figure 23 for the removal of the impeller and mechanical seal.

1. Remove the three strainer bolts (item 147) that secure, strainer to the suction cover (item 176). Remove strainer (item 146).
2. Remove the four suction cover bolts (item 177) that secure the suction cover (item 176) to the casing (item 1). Remove suction cover.
3. Remove suction cover packing (item 179) from suction cover and friction disc (items 176 and 2).
4. Remove impeller nut (item 4) and washer (item 53).
5. Remove impeller (item 3) and impeller key (item 6) from motor shaft. Remove mechanical seal (item 60).
6. Remove adjustment liner (item 47).
7. Reassemble in reverse order.

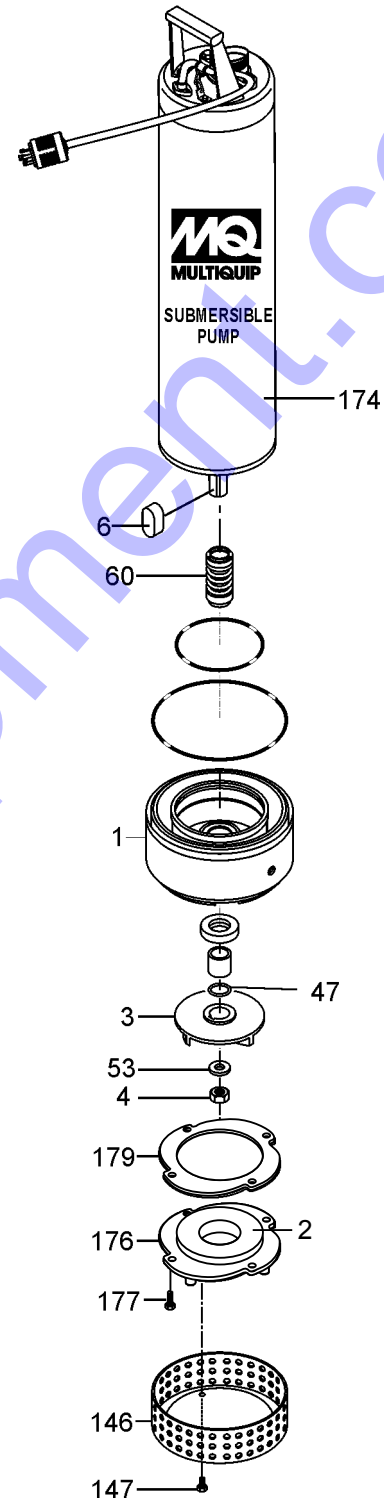

Figure 23. Impeller/Mechanical Seal Removal

Electrical Insulation Testing

Why perform electrical insulation testing?

Electrical insulation starts to age as soon as it's made. Harsh environments, especially those with extreme temperature changes and/or chemical contamination, cause further deterioration of the insulation (power cord).

As a result, personnel safety (electrocution/shock) and power reliability can suffer resulting in higher operating cost and maintenance.

What is Insulation Resistance Testing

Insulation resistance testing applies a regulated stabilized high voltage (Figure 24), typically 500 VDC or greater across a dielectric (power cord). Measuring the amount of **leakage current** flowing through the dielectric will yield a resistive measurement in megohms.

Insulating Material Testing

To verify the integrity of the pump's insulating material (power cable) it will be necessary to perform an electrical insulation test. Any electrical insulation must have the opposite characteristic as the conductor: it should resist the flow of current, keeping it within the conductor.

To measure the IR (current x resistance), the use of an IR tester must be employed. This IR tester is a portable device that is a resistance meter (ohmmeter) with a built in DC generator that develops a high DC voltage.

The high DC voltage from the IR tester is usually 500 VDC or more. This voltage, when applied causes a small current to flow through and over the insulation's surfaces. The tester provides a direct reading of IR in megohms.

A high resistance reading would indicate a "**good**" insulation, meaning very little current is escaping through the insulation. While a relatively low resistance reading would indicate a **poor** insulation, meaning a significant amount of current may be leaking through and along the insulation.

NOTICE

Insulation resistance is moisture and temperature sensitive. When temperature increases, insulation resistance decreases, and vice versa.

When performing this test measurement, perform the test using the same test parameters as used in the initial testing.

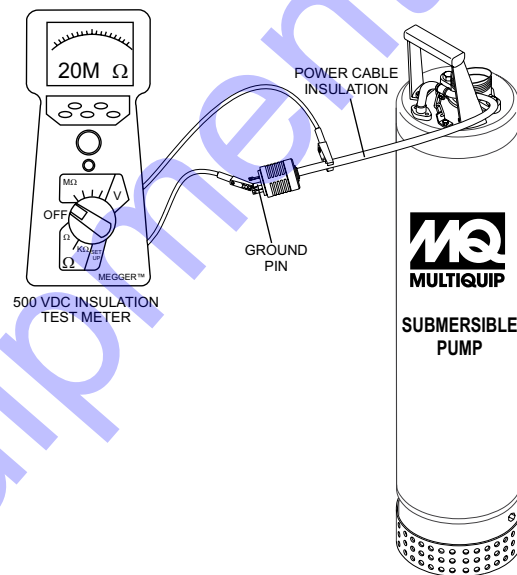

Figure 24. Insulation Tester Application

! DANGER



Read and follow the manufacturer's users manual prior to operating insulation tester (megaohm meter). This meter generates a test voltage of 500 volts or greater. Only qualified and trained personnel should use this equipment. The possibility exists of severe **electrical shock, electrocution even death!**, when using insulation tester.

Table 8. Pump Troubleshooting

SYMPTOM	POSSIBLE PROBLEM	SOLUTION
Pump Fails To Start	Incorrect voltage/amps?	Check that proper voltage (230 VAC, 60 Hz, single-phase) is being supplied to the pump. Also check that there is an adequate amount of current (amps) to run the pump. Check power source circuit breaker.
	Check electrical connections?	If using float switches check wiring, inspect power cord.
	Blown power fuse or tripped circuit breaker?	Replace fuse check circuit breaker, check cause of blown fuse or tripped breaker.
	Impeller locked?	Disconnect power cord and check for clogging. Unclog pump. Check overload protection device.
	Wet motor windings?	Use multimeter to check motor insulation. Insulation resistance must be approximately 15 megaohms. If resistance is low, disassemble pump motor and bake windings to dry them.
	Defective motor and pump bearings?	Check for excessive bearing wear, if worn replace bearings. Replace motor if defective.
Pump Fails to Deliver Full Output	Twisted or restricted discharge hose?	Lay hose flat un-kinked. Remove clog from hose line.
	Clogged pump strainer?	Clean strainer.
	Low voltage?	Use a voltmeter to check voltage while pump is energized. Voltage must be within $\pm 10\%$. Check power source (no load and load). If an extension cord is used, make sure it has adequate current-carrying capacity for the required length. See Table 4.
	Impeller worn?	Replace impeller.
Water in Mechanical Seal Oil	Defective mechanical seal?	Replace mechanical seal.
	Loose Oil Fill Plug?	Tighten securely. Apply teflon tape.

CB6 WIRING DIAGRAM

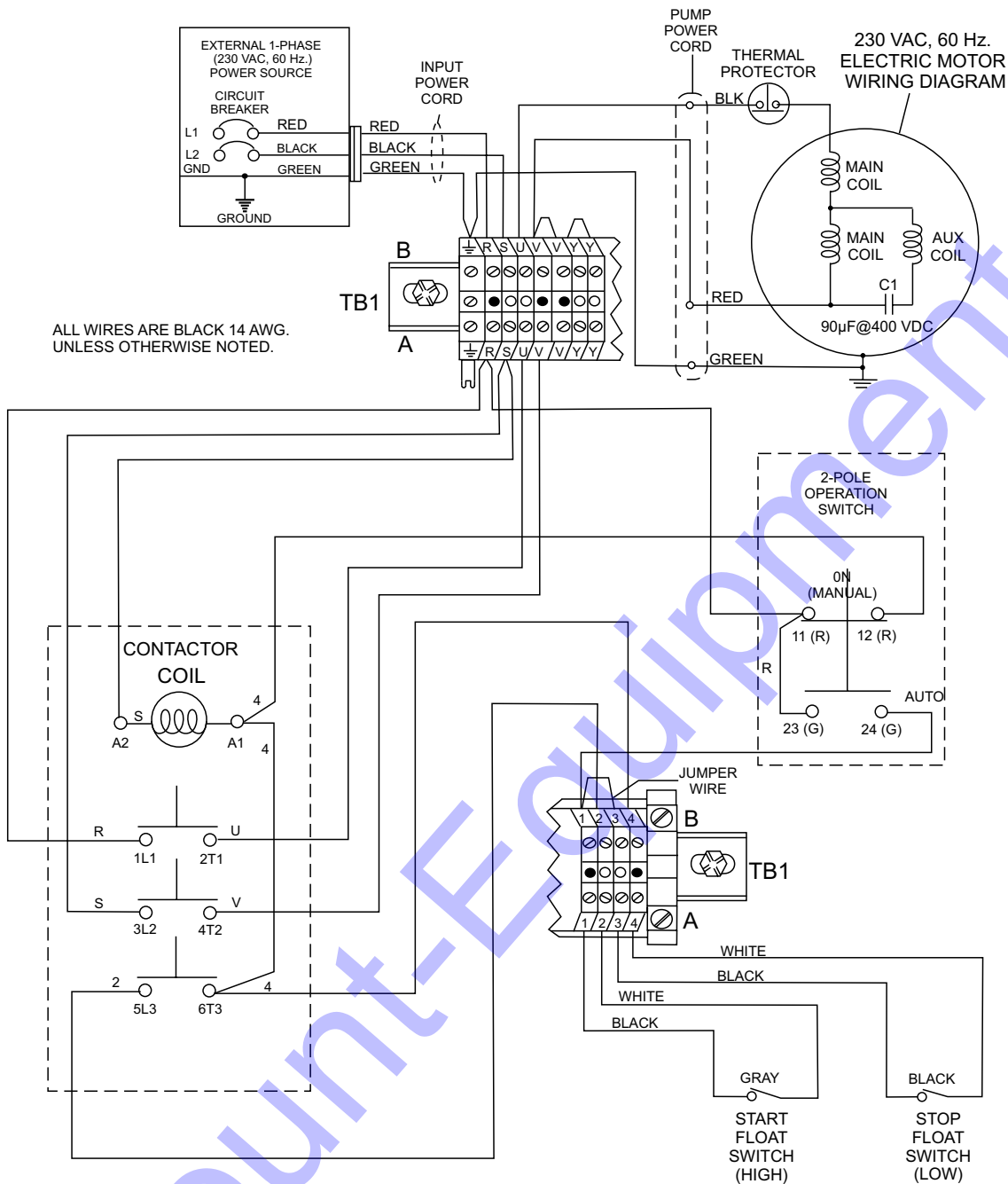

WARNING
CONTROL BOX INSTALLATION IS TO BE PERFORMED BY A LICENSED ELECTRICIAN OR QUALIFIED PERSONNEL.
THE POSSIBILITY OF ELECTRICAL SHOCK OR ELECTROCUTION EXISTS, WHICH COULD CAUSE SEVERE BODILY HARM EVEN DEATH!

Figure 25. CB6 Wiring Diagram

CB200 WIRING DIAGRAM

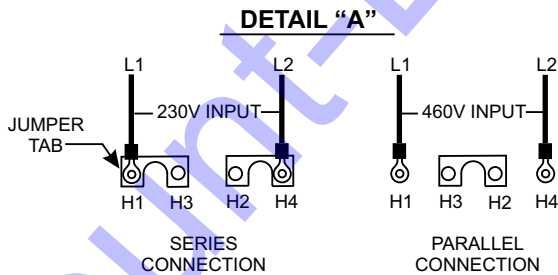
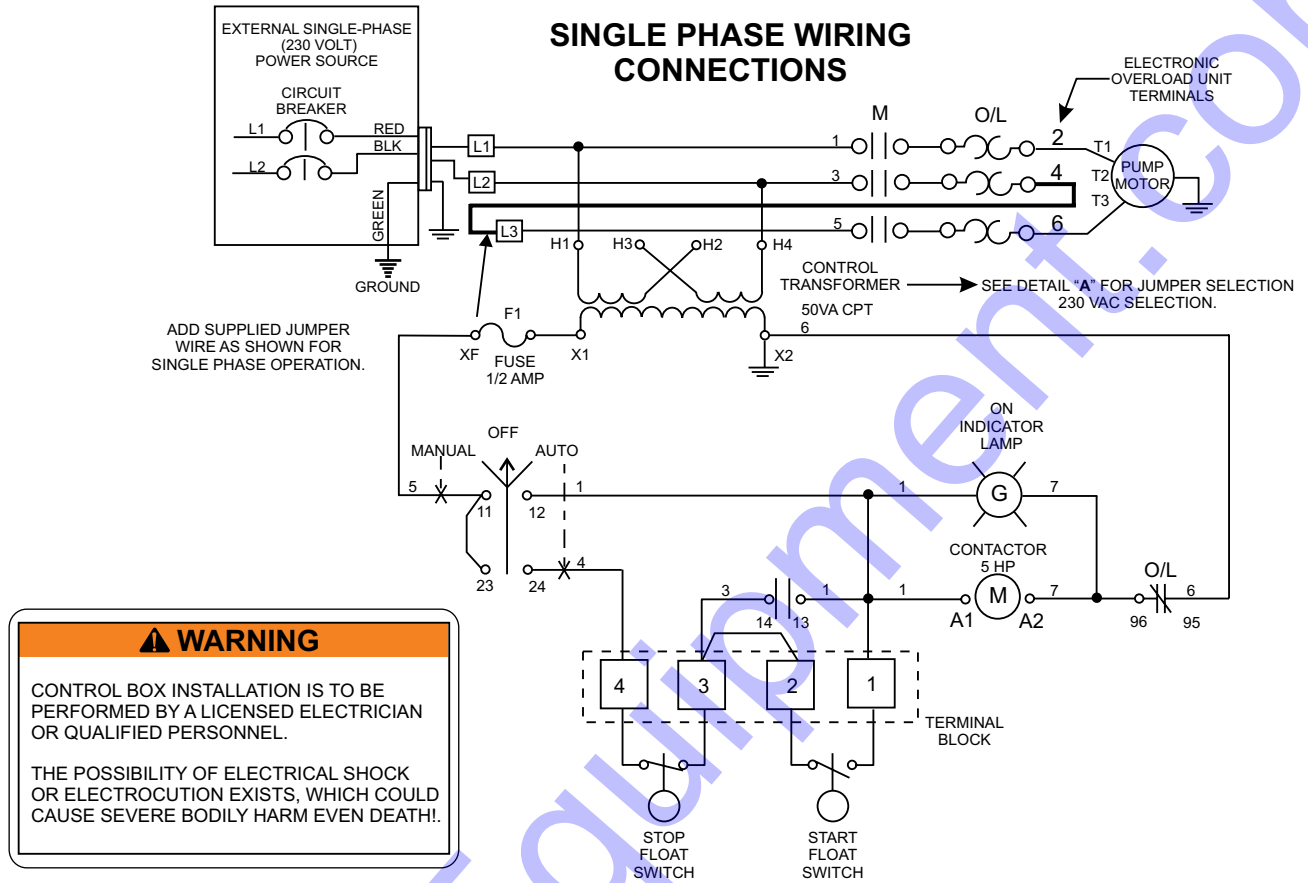

NOTES

SINGLE PHASE INSTALLATION

The transformer connections must be set up for 230 volts. Reference detail "A". Add the supplied jumper wire between terminal 4 of the electronic overload unit and L3 on the input terminal block.

ELECTRONIC OVERLOAD MODULE

This control box is equipped with an electronic overload unit. The FLC (A) dial on the overload module must be set in accordance with the requirements of the pump.

Figure 26. CB200 Wiring Diagram

EXPLANATION OF CODE IN REMARKS COLUMN

The following section explains the different symbols and remarks used in the Parts section of this manual. Use the help numbers found on the back page of the manual if there are any questions.

NOTICE

The contents and part numbers listed in the parts section are subject to change **without notice**. Multiquip does not guarantee the availability of the parts listed.

SAMPLE PARTS LIST

NO.	PART NO.	PART NAME	QTY.	REMARKS
1	12345	BOLT	1	INCLUDES ITEMS W/%
2%		WASHER, 1/4 IN.		NOT SOLD SEPARATELY
2%	12347	WASHER, 3/8 IN. ...	1	MQ-45T ONLY
3	12348	HOSE	A/R	MAKE LOCALLY
4	12349	BEARING	1	S/N 2345B AND ABOVE

NO. Column

Unique Symbols — All items with same unique symbol

(@, #, +, %, or >) in the number column belong to the same assembly or kit, which is indicated by a note in the “Remarks” column.

Duplicate Item Numbers — Duplicate numbers indicate multiple part numbers, which are in effect for the same general item, such as different size saw blade guards in use or a part that has been updated on newer versions of the same machine.

NOTICE

When ordering a part that has more than one item number listed, check the remarks column for help in determining the proper part to order.

PART NO. Column

Numbers Used — Part numbers can be indicated by a number, a blank entry, or TBD.

TBD (To Be Determined) is generally used to show a part that has not been assigned a formal part number at the time of publication.

A blank entry generally indicates that the item is not sold separately or is not sold by Multiquip. Other entries will be clarified in the “Remarks” Column.

QTY. Column

Numbers Used — Item quantity can be indicated by a number, a blank entry, or A/R.

A/R (As Required) is generally used for hoses or other parts that are sold in bulk and cut to length.

A blank entry generally indicates that the item is not sold separately. Other entries will be clarified in the “Remarks” Column.

REMARKS Column

Some of the most common notes found in the “Remarks” Column are listed below. Other additional notes needed to describe the item can also be shown.

Assembly/Kit — All items on the parts list with the same unique symbol will be included when this item is purchased.

Indicated by:

“INCLUDES ITEMS W/(unique symbol)”

Serial Number Break — Used to list an effective serial number range where a particular part is used.

Indicated by:

“S/N XXXXX AND BELOW”

“S/N XXXX AND ABOVE”

“S/N XXXX TO S/N XXX”

Specific Model Number Use — Indicates that the part is used only with the specific model number or model number variant listed. It can also be used to show a part is NOT used on a specific model or model number variant.

Indicated by:

“XXXXX ONLY”

“NOT USED ON XXXX”

“Make/Obtain Locally” — Indicates that the part can be purchased at any hardware shop or made out of available items. Examples include battery cables, shims, and certain washers and nuts.

“Not Sold Separately” — Indicates that an item cannot be purchased as a separate item and is either part of an assembly/kit that can be purchased, or is not available for sale through Multiquip.

SUGGESTED SPARE PARTS

ST3020B1/ST3020BCUL SUBMERSIBLE PUMP

1 TO 3 UNITS

Qty.	P/N	Description
10203020B1120AC CORD WITH GLAND
10202020060MECHANICAL SEAL
10203020B1103PACKING

NOTICE

Part numbers on this Suggested Spare Parts list may supersede/replace the part numbers shown in the following parts lists.

PUMP ASSY.

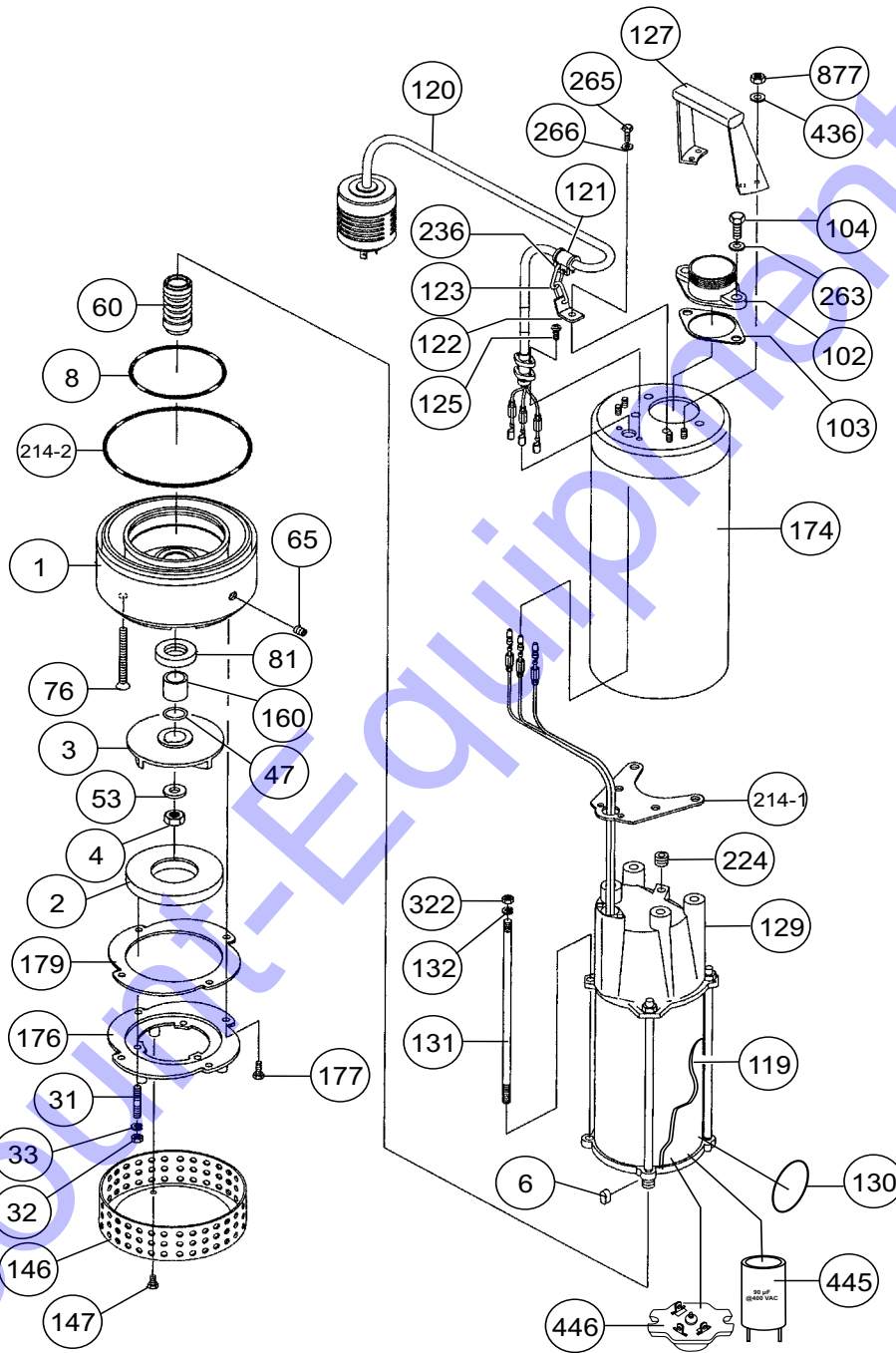

PUMP ASSY.

<u>NO.</u>	<u>PART NO.</u>	<u>PART NAME</u>	<u>QTY.</u>	<u>REMARKS</u>
1	0202020B001	CASING	1	
2	0202020B002	FRICTION DISC	1	
3	0202020B003	IMPELLER	1	
4	0202020004	IMPELLER NUT	1	
6	0202020B006	IMPELLER KEY	1	
8	0202020B008	CASING COVER	1	
31	0202020B031	STUD BOLT	3	
32	0202020B032	NUT	3	
33	0202020B003	WASHER	3	
47	0202020047	LINER	1	QTY. AS REQUIRED
53	0202020053	WASHER	1	
60	0202020060	MECHANICAL SEAL	1	
65	0202020065	OIL PLUG	1	
76	0202020B076	SCREW	4	
81	0202020081	OIL SEAL	1	
102	0203020B1102	DISCHARGE PORT	1	
103	0203020B1103	PACKING	1	
104	0203020B1104	STUD BOLT	2	
119	0203020B1119	MOTOR	1	
120	0203020B1120	AC CORD W/CORD GLAND	1	
121	0202020B1121	CORD CLAMP	1	
122	0202020B1122	HANGER METAL	1	
123	0202020B1123	CHAIN	1	
125	0202020B1125	SCREW	2	
127	0203020B1127	CARRYING HANDLE	1	
129	0203020B1129	MOTOR HEAD COVER	1	
130	0202020B130	O-RING	1	
131	0202020B131	BOLT	4	
132	0202020B132	SPRING WASHER	4	
146	0202020B146	STRAINER	1	
147	0202020B147	BOLT	3	
160	0201503160	SLEEVE	1	
174	0203020B1174	OUTER PIPE	1	
176	0202020B176	SUCTION COVER	1	
177	0202020B177	BOLT	4	
179	0202020B178	PACKING	1	
214-1	0203020B1214A	PACKING	1	
214-2	0203020B1214B	PACKING	1	
224	0202020224	PLUG	1	
236	0201503A236	S-TIP	1	
263	0203020B1263	WASHER	2	
265	020-3020B1265	BOLT	2	
266	0203020B1266	WASHER	2	
322	0202020B322	NUT	2	
436	0203020B1436	WASHER	2	
445	0203020B1445	CAPACITOR	1	
446	0203020B1446	AUTO-CUT PROTECTOR	1	
877	0203020B1877	NUT	4	

MOTOR ASSY.

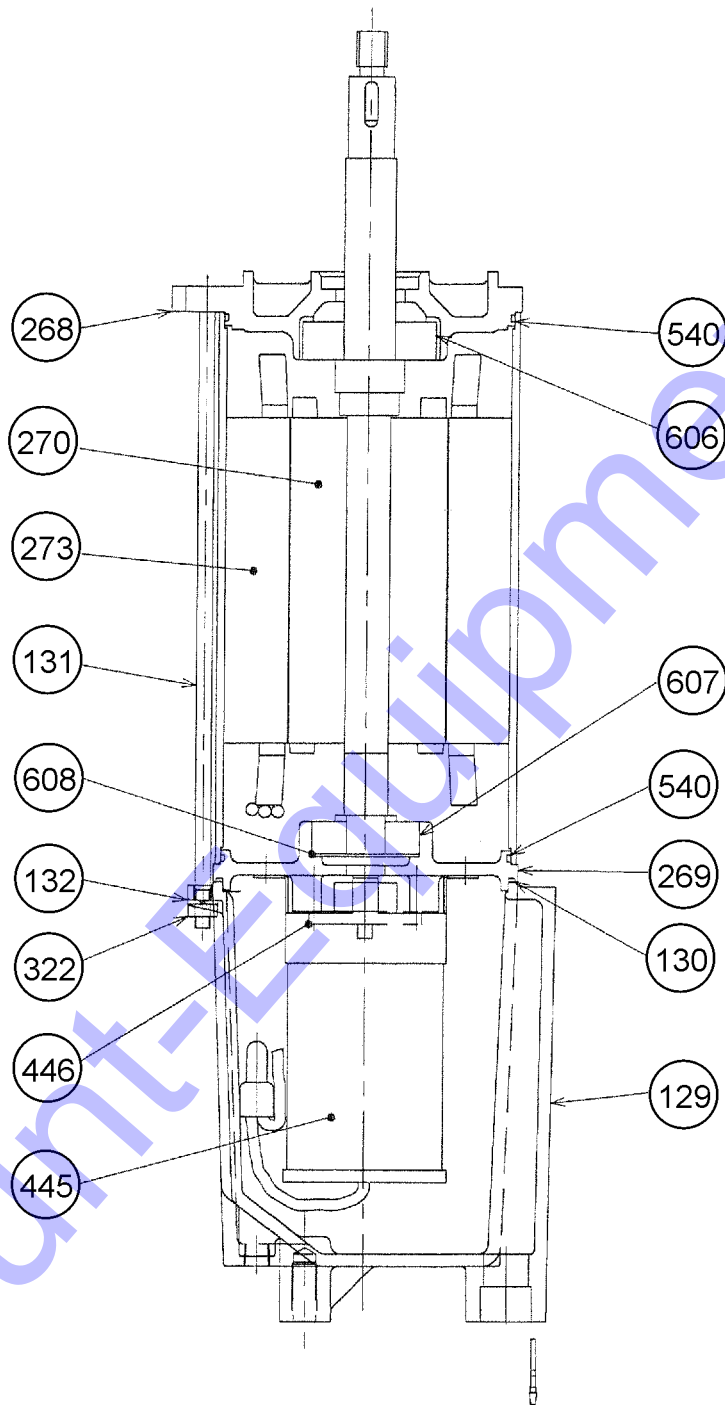

MOTOR ASSY.

NO.	PART NO.	PART NAME	QTY.	REMARKS
129	0203020B1129	MOTOR HEAD COVER	1	
130	0203020B1130	PACKING	1	
131	0202020B131	BOLT	4	
132	0202020B132	SPRING WASHER	4	
268	0202020B268	MOTOR A BRACKET	1	
269	0202020B269	MOTOR B BRACKET	1	
270	0203020B1270	MOTOR ROTOR	1	
273	0203020B1273	MOTOR STATOR	1	
322	0202020B322	NUT	4	
445	0203020B1445	CAPACITOR	1	
446	0203020B1446	AUTO CUT PROTECTOR	1	
540	0201503A540	PACKING	2	
606	0202020B606	MOTOR A BEARING	1	
607	0202020B607	MOTOR B BEARING	1	
608	0202020B608	WAVE WASHER	2	

Discount Equipment

Discount-Equipment.com is your online resource for commercial and industrial quality parts and equipment sales.

Locations:

Florida (West Palm Beach): [561-964-4949](tel:561-964-4949)

Outside Florida TOLL FREE: [877-690-3101](tel:877-690-3101)

Need parts? Check out our website at www.discount-equipment.com

Can't find what you need?

Click on this link: <http://www.discount-equipment.com/category/5443-parts/> and fill out the request form.

Please have the machine model and serial number available in order to help us get you the correct parts. One of our experienced staff members will get back to you with a quote for the right part that your machine needs.

We sell worldwide for the brands: Genie, Terex, JLG, MultiQuip, Mayco, Toro/Stone, Diamond Products, Magnum, Airman, Mustang, Power Blanket, Nifty Lift, Atlas Copco, Chicago Pneumatic, Allmand Brothers, Essick, Miller Spreader, Skyjack, Lull, Skytrak, Tsurumi, Husquvarna/Target, Whiteman-Concrete/Mortar, Stow-Concrete/Mortar, Baldor, Wacker, Sakai, Snorkel, Upright, Mi-T-M, Sullair, Neal, Basic, Dynapac, MBW, Weber, Bartell, Bennar Newman, Haulotte, Ditch Runner, Blaw-Knox, Himoina, Best, Buddy, Crown, Edco, Wyco, Bomag, Laymor, Terremite, Barreto, EZ Trench, Takeuchi, Basic, Bil-Jax, Curtis, Gehl, Heli, Honda, ICS/PowerGrit, Puckett, Waldon, ASV, IHI, Partner, Imer, Clipper, MMD, Koshin, Rice, Gorman Rupp, CH&E, Cat Pumps, Comet, General Pump, Giant, AMida, Coleman, NAC, Gradall, Square Shooter, Kent, Stanley, Tamco, Toku, Hatz, Kohler, Robin, Wisconsin, Northrock, Oztec, Toker TK, Rol-Air, Small Line, Wanco, Yanmar

New Equipment - Used Equipment - Rental Equipment - Parts and Accessories

Discount Equipment

www.discount-equipment.com

561-964-4949

Sales: info@Discount-Equipment.com

Parts: wbparts@Discount-Equipment.com