



# OPERATOR MANUAL

**MODELS: CF24E, CF36, CF46**  
**4 Blades**



## POWER TROWEL

A 100% employee-owned American manufacturer

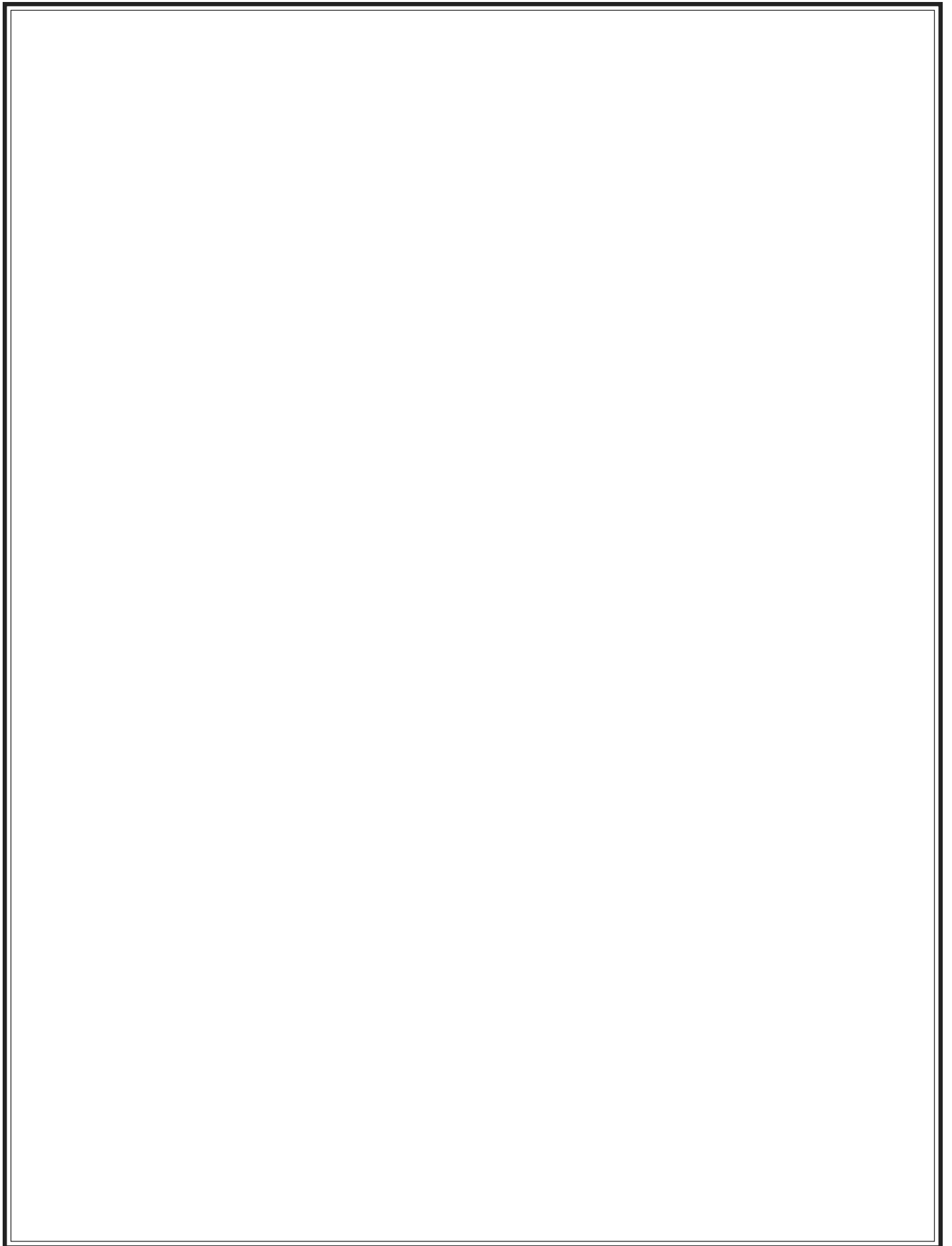

# Table of Contents

CF Power Trowel

TABLE OF CONTENTS .....	3
FOREWORD .....	4
LIMITED WARRANTY .....	5
TECHNICAL DATA .....	6-9
Specifications .....	6
Torque Chart - Imperial .....	7
Torque Chart - Metric .....	8
Hardware Identification .....	10
HEALTH & SAFETY .....	11-12
Safety Training .....	10
Safety Precautions .....	11-12
INTRODUCTION .....	14-17
Intro .....	14
Operating Principle .....	14
Delivery Checks .....	14
Before Starting .....	14
Determining the Right Machine .....	14
Standard Features .....	15
Preparation for Service .....	15
Location and Use of Controls .....	16
Adjust Tilt Lock Nut .....	17
OPERATIONS .....	18
To Start .....	18
To Shut Off .....	18
Initial Operation .....	18
Floating Operation .....	18
Finishing Operation .....	18
MAINTENANCE .....	19
Maintenance, Lubrication and Adjustment .....	19
Lubrication .....	19
Trowel Gearcase .....	19
Arm Bearing .....	19
CALIFORNIA PROPOSITION 65 .....	IBC

MANUFACTURED UNDER ONE OR MORE OF THE FOLLOWING PATENTS AND OTHERS  
PENDING, 4046483, 4232980, CAN.-1131361

DYNA-CLUTCH is a trademark of the Manufacturer.

# User Information

## Foreword

These instructions include:

- Safety regulations
- Operating instructions
- Maintenance instructions

**These instructions have been prepared for operation on the construction site and for the maintenance engineer.**

These instructions are intended to simplify operation of the machine and to avoid malfunctions through improper operation.

Observing the maintenance instructions will increase the reliability and service life of the machine when used on the construction site and reduce repair costs and downtimes.

**Always keep these instructions at the place of use of the machine.**

**Only operate the machine as instructed and follow these instructions.**

**Observe the safety regulations as well as the guidelines of the civil engineering trade association. Observe safety rules for the operation of equipment and the pertinent regulations for the prevention of accidents.**

Stone Construction Equipment, Inc. is not liable for the function of the machine when used in an improper manner and for other than the intended purpose.

Operating errors, improper maintenance and the use of incorrect operating materials are not covered by the warranty.

The above information does not extend the warranty and liability conditions of business of Stone Construction Equipment, Inc.

Please enter the following data. This will help expedite any service or warranty work.

1. Machine Type: \_\_\_\_\_

Machine S/N: \_\_\_\_\_

2. Engine Type: \_\_\_\_\_

Engine S/N: \_\_\_\_\_

3. VIN: \_\_\_\_\_

4. Purchase Date: \_\_\_\_\_

5. Dealer/Distributor Information:

Name: \_\_\_\_\_

Address: \_\_\_\_\_

\_\_\_\_\_

Phone #: \_\_\_\_\_

Fax #: \_\_\_\_\_

6. Battery  
Manufacturer: \_\_\_\_\_

Battery Type: \_\_\_\_\_

Battery S/N: \_\_\_\_\_

**Location of above information:**

1. Information on S/N tag.
2. Information on engine tag.
3. Information on S/N tag - if applicable.
4. Date you purchased machine.
5. Dealer machine was purchased from.
6. Information on battery and battery warranty card.

---

**Stone Construction Equipment, Inc.**  
**P.O. Box 150, Honeoye, New York 14471**  
**Phone: (800) 888-9926**  
**Fax: (716) 229-2363**

## L i m i t e d   W a r r a n t y

The Manufacturer warrants that products manufactured shall be free from defects in material and workmanship that develop under normal use for a period of 90 days for concrete vibrators and electric pumps, one year for Rhino®, Bulldog®, Wolfpac Rollers™, trowels, Stompers®, saws, forward plates, engine powered pumps, and 6 months for all other products from the date of shipment. The foregoing shall be the exclusive remedy of the buyer and the exclusive liability of the Manufacturer. Our warranty excludes normal replaceable wear items, i.e. gaskets, wear plates, seals, O-rings, V-belts, drive chains, clutches, etc. Any equipment, part or product which is furnished by the Manufacturer but manufactured by another, bears only the warranty given by such other manufacturer. (The Manufacturer extends the warranty period to "Lifetime" for the drum bearings and seals for the mortar mixers, and agrees to furnish, free of charge, the bearings and seals only upon receipt of the defective parts. The warranty is two years for eccentric bearings on the forward plate compactors, mortar and plaster mixer drums, trowel gearboxes and five years on the Bulldog trench roller eccentric bearings.) A Warranty Evaluation Form must accompany all defective parts. Warranty is voided by product abuse, alterations, and use of equipment in applications for which it was not intended, use of non-manufacturer parts, or failure to follow documented service instructions. The foregoing warranty is exclusive of all other warranties whether written or oral, expressed or implied. No warranty of merchantability or fitness for a particular purpose shall apply. The agents, dealer and employees of Manufacturer are not authorized to make modification to this warranty, or additional warranties binding on Manufacturer. Therefore, additional statements, whether oral or written, do not constitute warranty and should not be relied upon.

The Manufacturer's sole responsibility for any breach of the foregoing provision of this contract, with respect to any product or part not conforming to the Warranty or the description herein contained, is at its option (a) to repair, replace or refund such product or parts upon the prepaid return thereof to location designated specifically by the Manufacturer. Product returns not shipped prepaid or on an economical transportation basis will be refused (b) as an alternative to the foregoing modes of settlement - the Manufacturer's dealer to repair defective units with reimbursement for expenses, except labor, and be reviewed with the Manufacturer prior to repair. A Warranty Evaluation Form must accompany all warranty claims.

Except as set forth hereinabove and without limitation of the above, there are no warranties or other affirmations which extends beyond the description of the products and the fact hereof, or as to operational efficiency, product reliability or maintainability or compatibility with products furnished by others. In no event whether as a result of breach of contract or warranty or alleged negligence, shall the Manufacturer be liable for special or consequential damages including but not limited to: Loss of profits or revenues, loss of use of the product or any associated product, cost of capital, cost of substitute products, facilities or services or claims of customers.

No claim will be allowed for products lost or damaged in transit. Such claims should be filed with the carrier within fifteen days.

Effective April 1, 1998.



Stone Construction Equipment, Inc.  
32 East Main Street, P. O. Box 150  
Honeoye, NY 14471-0150

Phone: 1-800-888-9926 • 1-716-229-5141  
Fax: 1-716-229-2363

www.stone-equip.com • e-mail: [sceney@mcimail.com](mailto:sceney@mcimail.com)

# Technical Data

# Trowels – Specifications

MODEL	STONE CF24E	STONE CF364	STONE CF464
<b>Dimensions</b>			
Operating Wt. (kg)	130 lbs. (59)	160 - 185 lbs. (72.7 - 84)	180 - 225 lbs. (82 - 102.3)
Diameter (cm)	24" (61)	36" (91.5)	46" (116)
<b>Blades:</b>			
Number	4	4	4
Finish (cm)	-	6" x 14" (15.2 x 35.6)	6" x 18" (15.2 x 45.7)
Combination (cm)	5"x9" (12.7 x 22.9)	8" x 14" (20.3 x 35.6)	8" x 18" (20.3 x 45.7)
Float (cm)	-	10" x 14" (25.4 x 35.6)	10" x 18" (25.2 x 45.7)
<b>Blade Positioning / Blade Leveler</b>	Self-aligning aircraft bearings - positive blade positioning, inf. var. blade leveler	Self-aligning aircraft bearings - positive blade positioning, inf. var. blade leveler	Self-aligning aircraft bearings - positive blade positioning, inf. var. blade leveler
<b>Operating System</b>			
Engine hp/(kw)	4 hp Honda (2.98) 4.5hp Robin (3.36)	5 hp B&S, (3.7) 5 hp B&S I/P, (3.7) 8hp B&S I/P, (5.9) 5.5 hp Honda, (4.1) 8 hp Honda, 5.9) 6hp Robin (4.47) 9hp Robin (6.71)	8 hp B&S I/P, (5.9) 8 hp Honda, (5.9) 9hp Robin (6.71)
RPM'S (Hertz)	50 - 130 (.8 - 2.1)	50 - 130 (.8 - 2.1)	50 - 130 (.8 - 2.1)
<b>Gear Box</b>	Hardened steel worm and bronze gear, cast aluminum gear box, tapered roller bearings	Hardened steel worm and bronze gear, cast aluminum gear box, tapered roller bearings	Hardened steel worm and bronze gear, cast aluminum gear box, tapered roller bearings
<b>Standard Features:</b>			
<b>Safety Shutoff</b>	Patented Dyna-Clutch	Patented Dyna-Clutch	Patented Dyna-Clutch
<b>Handle</b>	Reinforced, contoured,	Reinforced, triple- tube, contoured, adjustable	Reinforced, triple- tube, contoured, adjustable
<b>Throttle</b>	T-handle Throttle (turns) w/1/4-turn locking	T-handle Throttle (turns) w/1/4-turn locking	T-handle Throttle (turns) w/1/4-turn locking
<b>Spider</b>	cast iron	cast iron	cast iron
<b>Stabilizing Ring</b>	rotating	rotating	rotating
<b>Lifting Eye</b>	hand lift	standard	standard
<b>Gauges</b>	oil sight gauge	oil sight gauge	oil sight gauge
<b>Shipped</b>	assembled	assembled	assembled
<b>Other Features:</b>	cushioned handgrips, rotating guard	cushioned handgrips, shock-mounted stationary guard	cushioned handgrips, shock-mounted stationary guard
<b>Warranty</b>	2-year gear case	2-year gear case	2-year gear case

# Technical Data

## Machine Sound and Vibration Measurements

### Sound and Vibration Measurements

Sound Pressure Values as measured are per the following:

Noise 1	Model/Configuration	
Sound Pressure	CF36	CF46
at operator's ear	5.5 Honda	8 Honda
	92dBA	93dBA

RMS acceleration on the handle were measured per the following:

meter/sec <sup>2</sup> RMS	8.27	7.6
----------------------------	------	-----

Sound and vibration values have been taken in accordance to the EEC machine regulation (edition 93/68/EEC)

Sound Pressure measurements were taken with Simpson model 886-2 type 2 meter, calibrated 1/31/98

Acceleration measurements were taken with Quest Tech model VI-100 meter, calibrated 4/17/96

Sound and vibration measurements were obtained with machine operating at maximum engine speed of 3600 RPM.

Unit measurements were taken on steel test plate.

c:\winnt\bonnie\sound\_cf feb 2000.doc

# Technical Data

## Torque Chart - Imperial

### SAE GRADE 5 Coarse Thread

SIZE	PLATED	
1/4 – 20 (.250)	6 ft. lbs.	8 Nm
5/16 – 18 (.3125)	13 ft. lbs.	18 Nm
3/8 – 16 (.375)	23 ft. lbs.	31 Nm
7/16 – 14 (.4375)	37 ft. lbs.	50 Nm
1/2 – 13 (.500)	57 ft. lbs.	77 Nm
9/16 – 12 (.5625)	82 ft. lbs.	111 Nm
5/8 – 11 (.625)	112 ft. lbs.	152 Nm
3/4 – 10 (.750)	200 ft. lbs.	271 Nm
7/8 – 9 (.875)	322 ft. lbs.	436.5 Nm
1 – 8 (1.000)	483 ft. lbs.	655 Nm

### SAE GRADE 8 Coarse Thread

SIZE	PLATED	
1/4 – 20 (.250)	9 ft. lbs.	12 Nm
5/16 – 18 (.3125)	18 ft. lbs.	24 Nm
3/8 – 16 (.375)	33 ft. lbs.	45 Nm
7/16 – 14 (.4375)	52 ft. lbs.	70 Nm
1/2 – 13 (.500)	80 ft. lbs.	108 Nm
9/16 – 12 (.5625)	115 ft. lbs.	156 Nm
5/8 – 11 (.625)	159 ft. lbs.	215 Nm
3/4 – 10 (.750)	282 ft. lbs.	382 Nm
7/8 – 9 (.875)	454 ft. lbs.	615 Nm
1 – 8 (1.000)	682 ft. lbs.	925 Nm

### SAE GRADE 5 Fine Thread

SIZE	PLATED	
1/4 – 28 (.250)	7 ft. lbs.	10Nm
5/16 – 24 (.3125)	14 ft. lbs.	19 Nm
3/8 – 24 (.375)	26 ft. lbs.	35 Nm
7/16 – 20 (.4375)	41 ft. lbs.	56 Nm
1/2 – 20 (.500)	64 ft. lbs.	87 Nm
9/16 – 18 (.5625)	91 ft. lbs.	123 Nm
5/8 – 18 (.625)	128 ft. lbs.	173 Nm
3/4 – 16 (.750)	223 ft. lbs.	302 Nm
7/8 – 14 (.875)	355 ft. lbs.	481 Nm
1 – 12 (1.000)	529 ft. lbs.	717 Nm
1 – 14 (1.000)	541 ft. lbs.	733 Nm

### SAE GRADE 8 Fine Thread

SIZE	PLATED	
1/4 – 28 (.250)	10 ft. lbs.	14Nm
5/16 – 24 (.3125)	20 ft. lbs.	27 Nm
3/8 – 24 (.375)	37 ft. lbs.	50 Nm
7/16 – 20 (.4375)	58 ft. lbs.	79 Nm
1/2 – 20 (.500)	90 ft. lbs.	122 Nm
9/16 – 18 (.5625)	129 ft. lbs.	175 Nm
5/8 – 18 (.625)	180 ft. lbs.	244 Nm
3/4 – 16 (.750)	315 ft. lbs.	427 Nm
7/8 – 9 (.875)	501 ft. lbs.	679 Nm
1 – 12 (1.000)	746 ft. lbs.	1011 Nm
1 – 14 (1.000)	764 ft. lbs.	1036 Nm



# Technical Data

## Torque Chart - Metric

### Property Class 8.8

ZINC-PLATED

SIZE	Coarse Thread		Fine Thread	
	Nm	ft. lbs.	Nm	ft. lbs.
M6	9.9	7	10	7
M8	24	18	25	18
M10	48	35	49	36
M12	83	61	88	65
M14	132	97	140	103
M16	200	148	210	155
M20	390	288	425	313
M24	675	498	720	531

### Property Class 10.9

ZINC-PLATED

SIZE	Coarse Thread		Fine Thread	
	Nm	ft. lbs.	Nm	ft. lbs.
M6	14	10	14	10
M8	34	25	35	26
M10	67	49	68	50
M12	117	86	125	92
M14	185	136	192	142
M16	285	210	295	218
M20	550	406	600	443
M24	950	701	1000	738

### Property Class 12.9

ZINC-PLATED

SIZE	Coarse Thread		Fine Thread	
	Nm	ft. lbs.	Nm	ft. lbs.
M6	16.5	12	16.5	12
M8	40	30	42	31
M10	81	60	82	60
M12	140	103	150	111
M14	220	162	235	173
M16	340	251	350	258
M20	660	487	720	531
M24	1140	841	1200	885

Conversion Factor: 1 ft. lb. = 1.3558 Nm

# Technical Data

# Hardware Key

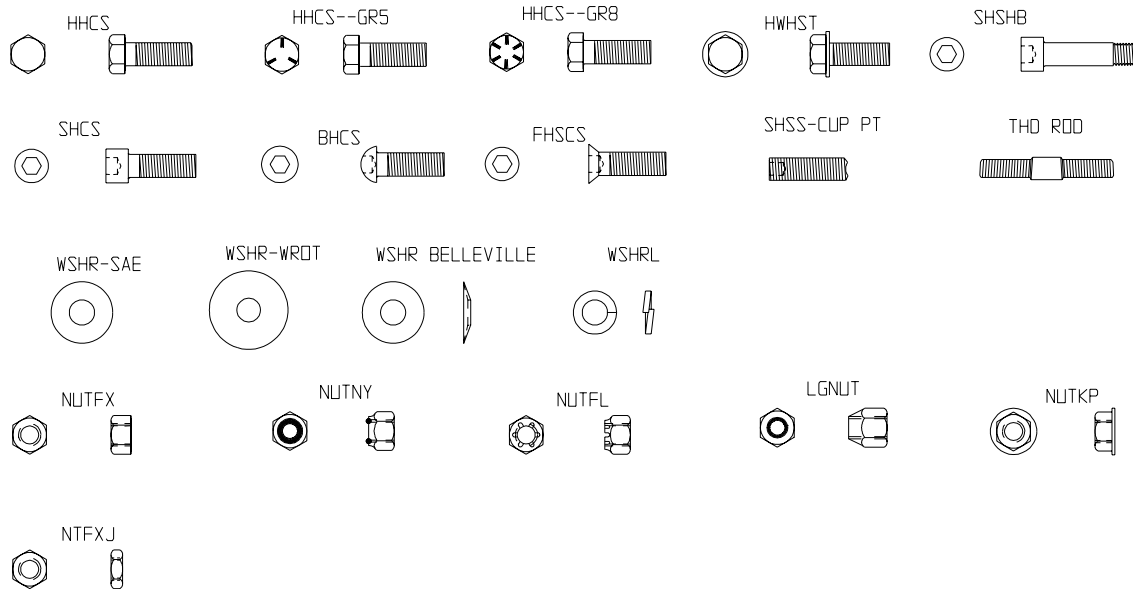

### **SAFETY**

These machines are designed to carry out the function of finishing concrete surfaces.

If used correctly, they will provide an effective and safe means of finishing and meet the appropriate performance standards.

It is essential that the operator of the machine is adequately trained in its safe operation, be authorized to operate it, and have sufficient knowledge of the machine to ensure that it is in full working order, before being put to use.

### **WARNING**

- Before using this equipment, study the entire owner's manual to become familiar with its operation. Do not allow untrained or unauthorized personnel, especially children, to operate this equipment. Use only factory authorized parts for service.
- When warning decals are destroyed or missing, contact the Manufacturer immediately at 1-800-888-9926 for replacement. For the safety of yourself and others, it is imperative that the following rules are observed. Failure to do so may result in serious injury or death.

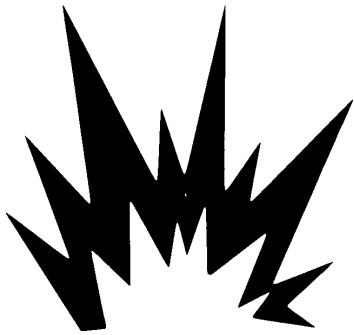

#### USE COMMON SENSE WHEN HANDLING FUELS

- Transport and handle fuel only when contained in approved safety containers.
- Do not smoke when refueling the engine or during any other fuel handling operation.
- Do not refuel the unit with the engine running or while hot.
- If fuel is spilled during refueling, wipe it off from the engine immediately and discard the rag in a safe place. Do not operate the unit if fuel or oil leaks exist-repair immediately.
- Never operate this equipment in an explosive atmosphere.

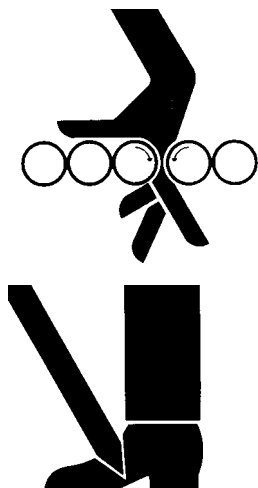

- Never perform any work on the unit while it is running. Before working on it, stop the engine and disconnect the spark plug wire to prevent accidental starting.
- Do not operate this unit without all guards in place. Keep hands, feet, clothing and jewelry away from the unit blades and all moving parts. Rotating and moving parts will cause serious injury if contacted during operation.
- Do not allow anyone to stand or lean on the unit during operation.

# Health & Safety

## Safety Precautions

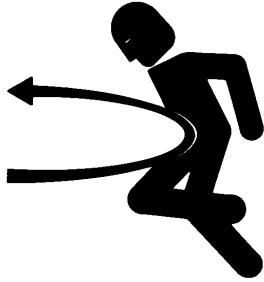

- Keep the patented Dyna-Clutch safety system in adjustment and good operating condition at all times. Do not operate the trowel if it does not work properly. Out of control Trowels can cause serious personal injury and damage to fresh concrete surfaces. The Dyna-Clutch system will automatically stop the unit if the operator loses control of it during operation.
- Make sure the Dyna-Clutch is disengaged (lever in the down position) before starting the unit. Keep one hand firmly on the handle while starting and do not let go of the handle during operation.



- Avoid contact with hot exhaust systems and engine parts.
- Allow engine to cool before performing any repairs or service.



- Ear protection required when operating this equipment.



- Never operate any gas powered equipment in a poorly ventilated or enclosed area.
- Avoid prolonged breathing of exhaust gases.

# Introduction

## Intro/Operating Principle/Delivery Checks/Before Starting/ Determining the Right Machine

Congratulations on your purchase of Stone Smooth Operator™ Power Trowels! You've made an excellent choice! The Power Trowels have been specifically designed as the ideal machine for the contractor who is engaged in professional concrete finishing.

Upon receipt of your Smooth Operator™ Power Trowel, **CAREFULLY CHECK FOR ANY FREIGHT DAMAGE.** Any damage should be immediately reported to the carrier and a claim registered.

The Smooth Operator™ Power Trowel is manufactured to the strictest specifications and inspection procedures. If any material or manufacturing defects are found, return the tag on the machine with assembler's signature and your findings to the manufacturer. We want to know when a product is less than perfect. We also welcome any and all input on how the product may serve you better.

### OPERATING PRINCIPLE

The following instructions were compiled to provide you information on how to obtain long and trouble free use of the unit. Periodic maintenance of this unit is essential. Read the manual in its entirety and follow the instructions carefully. Failure to do so may injure yourself or a bystander.

**DELIVERY CHECKS**--Immediately on taking delivery of your new equipment and before putting it into service:

- Read the handbook completely--it could save a great deal of unnecessary expense.
- Read the engine manual supplied.

- Check the general condition of the equipment--has it been damaged during delivery?
- Check engine oil level.
- Check fuel levels.

Recommended lubricants are detailed in the Care and Maintenance section.

**BEFORE STARTING**--These starting instructions are general guidelines only. Consult the engine manual included with this unit for specific instructions.

### DETERMINING THE RIGHT MACHINE

CF24E--Ideal compactness for small jobs.

CF364--Ideal all purpose size.

CF464--Utilized for jobs requiring maximum productivity.

The Stone Smooth Operator™ line provides the most popular sizes and configurations available. Engine options and trowel sizes can accommodate any job. Engines available are 4 hp, 5.5 hp, 8 or 9 horsepower Honda, Briggs or Robin with four finish or combo blade configurations in 24", 36" and 46" diameters.

# Introduction

## Standard Features/Preparation for Service

### STANDARD FEATURES

Your new CF Power Trowel comes standard with many features to enhance productivity, performance and safety. Listed below are just a few of these features.

**DYNA-CLUTCH**--Patented safety device automatically stops blade rotation without shutting down the engine, if the trowel gets away from the operator. Prevents injury to personnel and damage to the trowel and fresh concrete surfaces.

**ADJUSTABLE THROTTLE**--Located in a convenient location, this push-pull throttle control can be set to provide any blade speed from 50 to 130 RPM, and located in place at the desired operating speed.

**BENT ARM ADJUSTMENT**--Allows blades to be adjusted to compensate for bent arms caused by dropping or mishandling the trowel. Can be easily adjusted on-site for consistent finishing.

**HEAVY DUTY RING GUARD**--Protects operator and unit while providing lower center of gravity which contributes to unit stability and performance.

**CAST IRON SPIDER**--Extra strong, houses a double set of replaceable nylon bearings for each blade arm to insure alignment and eliminate seizing. Also contributes to lower center of gravity for increased trowel performance.

**ADJUSTABLE HANDLE**--Can be positioned to provide comfort and control for any operator's height. Equipped with flanged and cushioned motorcycle style hand grips to absorb vibration and minimize operator fatigue.

### PREPARATION FOR SERVICE

**BEFORE STARTING**--Your new CF Power Trowel has been assembled and tested at the factory. However, before placing the unit into service the following items should be checked:

**ASSEMBLY AND HARDWARE**--The unit is shipped completely assembled, except for installation of the adjustable handle. Consult the HANDLE ASSEMBLY exploded diagram and assemble the adjustable to the main handle with handle adjustment knob as shown.

Next check all hardware on the unit and engine. Consult the HARDWARE AND TORQUE CHART section of this manual for general guidelines and recommendations and tighten any suspicious hardware.

**OIL LEVEL AND LUBRICATION**--Check the oil level in the engine and gearbox. Engine and trowel warranties are VOID if this unit is run without oil. Also, check the blade arms and thrust bearing to make sure they have been greased. Consult the GENERAL LUBRICATION SECTION of this manual for lubrication requirements and instruction, if required.

**FUEL**--Fill the fuel tank on gasoline engines with clean gasoline from a safety can. DO NOT mix oil with the gasoline.



**FOLLOW SAFETY PRECAUTIONS  
WHENEVER HANDLING GASOLINE.**

# Introduction

## Location and Use of Controls

### LOCATION AND USE OF CONTROLS

Before operating this trowel, it is important to familiarize yourself, and any other personnel who will be using it, with the location and proper use of the controls to insure safe and efficient operation:

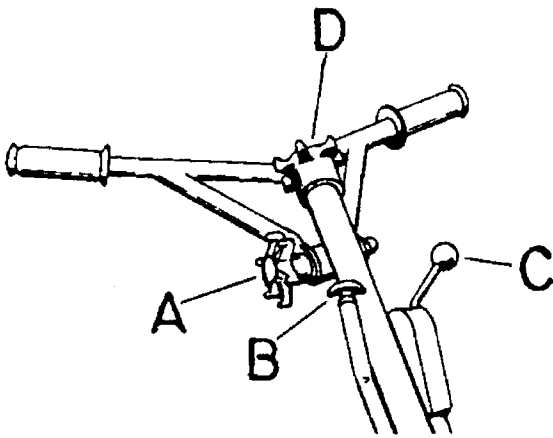

**A - HANDLE ADJUSTMENT KNOB** - to adjust the handle for maximum operator comfort and control, simply turn the knob counterclockwise one-quarter turn maximum to loosen, move handle to desired position and tighten knob to lock handle in place.

**B - THROTTLE CONTROL** - this is a push-pull type throttle control which can be locked at any desired blade speed from 50 to 130 RPM, to meet varying job conditions. To use, simply push or pull the throttle control to obtain the desired blade speed. To lock the throttle at the speed, turn the control clockwise. To unlock the throttle for further adjustments, turn the control counterclockwise approximately 1/4 turn.

**C - DYNA-CLUTCH LEVER** - this is a patented feature which acts as a safety device to stop the trowel from spinning out of control if the operator lets go of the handle. It also allows the operator to control the engagement and disengagement of the trowel blades independent of engine speed.

To use, simply move the lever all the way up to the RUN position to engage the trowel blades. To stop the blades from turning, push the lever all the way down to STOP position. In the event that the operator lets go of the handle while the blades are turning, the centrifugal force from the swing of the handle will throw the Dyna-Clutch lever to the STOP position. This prevents the unit from spinning out of control and causing injury to personnel or damage to the trowel and fresh concrete. Since the Dyna-Clutch system disengages the blades from the engine, rather than shutting down the engine to stop the blades, time is saved in getting the unit operating again. The operator simply moves the Dyna-Clutch lever to RUN position instead of having to restart the engine and readjust engine speed.

**D - TILT ADJUSTMENT KNOB** - adjusts the angle of the blades for different curing stages and conditions of the concrete. Turning the knob clockwise increases the angle of the blades to the concrete. Turning the knob counterclockwise flattens or decreases the angle of the blades.

**E - ProPitch™ Handle Option** -adjusts the angle of the blades for different curing stage and conditions of the concrete. Lift handle upwards to increase angle of the blades to the concrete. Depress trip button to release lock and decrease the angle of the blades.



# Introduction

## Adjust Tilt Knob Lock Nut/Linkage Rod

**TO ADJUST TILT LOCK NUT**--The tilt lock nut is located on the tilt rod assembly. Using the lifteye, raise the trowel with an overhead crane. Back off tilt knob until there is enough cable slack to access the tilt lock nut. For more tilt, loosen lock nut set screw and turn lock nut towards tilt knob, 1 turn, and lock set screw. Crank knob to full tilt position and check clearance between the tilt lever and gearcase for 1/64" (paper thickness). Repeat adjustment if required.

**NOTE: Cables may stretch over time and may need to be replaced if full tilt is no longer obtainable.**

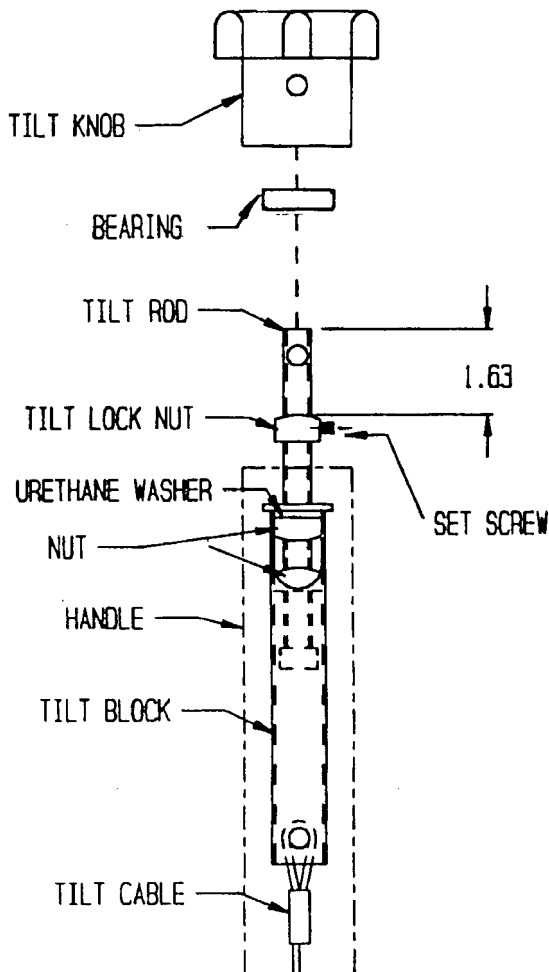

**TO ADJUST ProPitch™ LINKAGE Rod**--The linkage rod is fastened to a yoke end and a swivel by two nuts. To adjust follow the steps listed below.

1. Using the lifteye, raise the trowel using an overhead crane.
2. The lower end of the linkage rod is connected to a yoke and held in place with two (2) nuts. Loosen the nut on the upper end of the linkage rod to allow slack in the tilt cable when the ProPitch handle is in full tilt position.
4. With handle in full tilt position, adjust the nut on the backside of swivel at the upper end of linkage rod until the proper gap is achieved between the tilt lever and the gearcase--approximately 1/64 inch.
5. Tighten nut on the outside of swivel to lock linkage rod into position.
6. Repeat adjustment if required.

**NOTE: Cables may stretch over time and may need to be replaced if full tilt is no longer obtainable. Refer to Service and Parts Manual for full diagram and parts breakdown.**

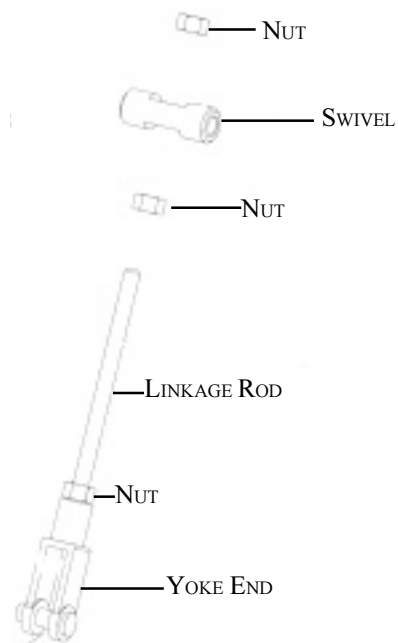

# Operations

## To Start/To Shut Off/Initial Operation/Floating Operation/Finishing Operation

**TO START**--Make sure the Dyna-Clutch lever is in the **STOP** position. If it is not, push the lever down to the **STOP** position before attempting to start the engine. Open fuel valve under fuel tank (if so equipped), open throttle approximately half way down and apply choke. Holding unit handle firmly with one hand, pull the starter rope sharply with the other about (3) times. When engine starts, open choke and adjust throttle as necessary to keep it running. If engine doesn't start after (3) pulls, open choke slightly.

**NOTE:** These starting instructions are general guidelines only. Since many engine options are available on CF Power Trowels, consult the **ENGINE MANUAL** included with the unit for specific instructions.

### TO SHUT OFF

**5 HP & 8 HP B&S ENGINES** - close throttle all the way, flip grounding tab against spark plug and hold there until the engine comes to a complete stop.

**4, 5.5 & 8 HP HONDA ENGINES** - close throttle all the way and flip oil minder kill switch to the **OFF** position.

**4.5, 8 & 9 HP ROBIN ENGINES** - close throttle all the way, depress kill switch button and hold down until engine stops completely.

**NOTE:** These stopping instructions are general guidelines only, consult the **ENGINE MANUAL** included with the unit for specific instructions.

**INITIAL OPERATION**--With engine started as instructed previously and at operating temperature, adjust speed to about half throttle. Hold the handle firmly with one hand and move the Dyna-Clutch lever to **RUN** position to engage the trowel blades.

### FLOATING OPERATION

Attach float or combination blades to the trowel arms, and when the concrete has set sufficiently to support the weight of the trowel, place the unit on the concrete. Start the unit and engage the blades as previously instructed. Using the tilt adjustment knob or ProPitch™ handle, adjust the blades to the float position--blades should be as flat to the concrete as possible with enough tension kept on the tilt adjustment cable to prevent the unit from dancing or chattering.

Guide the trowel over the concrete in a circular back and forth motion. Under normal conditions, you should be able to float a 30 x 30 foot area in approximately 15 minutes.

This operation will bring the water and fines to the surface, allowing for a smoother finish when finishing the concrete.

### FINISHING OPERATION

After floating, allow the concrete to set until it will support the weight of the trowel. Set the pitch to approximately 1/4" to 3/8" on the blades. If the blades start to dig into the concrete, decrease the amount of pitch.

# Maintenance

## Maintenance, Lubrication, Adjustment/Lubrication/Trowel Gearcase/Arm Bearing

### MAINTENANCE, LUBRICATION AND ADJUSTMENT

To get long and trouble free service from your new CF Power Trowel, it is essential to perform periodic maintenance on engine and machine mechanisms. Follow the guidelines listed below:

### LUBRICATION

#### A. ENGINE CRANKCASE

**Daily**--check oil level in engine. Engine warranty is VOID if it is run without oil. Add oil as required to keep crankcase full. Engine oil should be changed every 250 hours of operation, or once a year, whichever comes first.

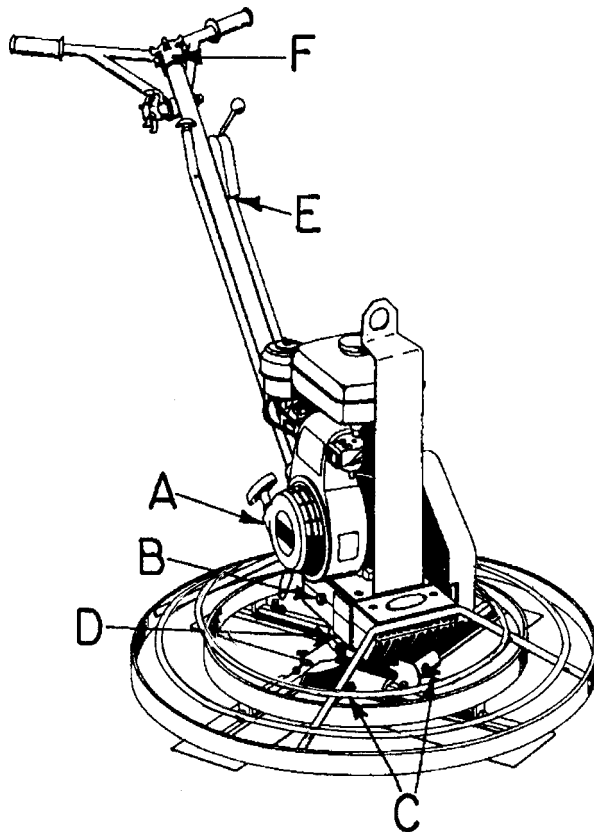

Oil requirements are as follows:

Temperatures above 40°F (4°C) - SAE 30  
Temperatures below 40°F (4°C) - SAE 5W20

These oil requirements are general guidelines only, for specific requirements consult the ENGINE MANUAL included with the unit.

#### B. TROWEL GEARCASE

**Daily**--check oil level in gearcase. Trowel warranty is VOID if it is run without oil. Oil level should fill the sight plug, located on the right side of the gearcase, when the unit is at rest on a level surface. Add oil as required to keep oil level at correct height. Gearcase oil should be changed every 250 hours of operation, or once a year, whichever comes first. Use 90 wt oil when changing or adding oil to the gearcase.

#### C. ARM BEARING

**Monthly**--grease arm bearing through the grease fittings in the spider. There are (3) fittings on (3) arm trowels and (4) fittings on (4) arm trowels. Pump grease into each fitting until clean grease comes out of spider at either end, thoroughly clean excess grease off from spider when all arms have been greased. Use any grade #1 lithium base grease.

#### D. THRUST BEARING

**Weekly**--grease with any grade 1 Lithium based grease to purge out any dirt or water. Wipe off excess grease.

**Yearly**--for bearing lubrication remove thrust bearing and clean thoroughly. Inspect for damage and replace if necessary or repack with any grade #1 lithium-based grease and reinstall. Refer to Spider Assembly Removal section in your Parts/Service Trowel Manual, P/N 56354 for spider removal.

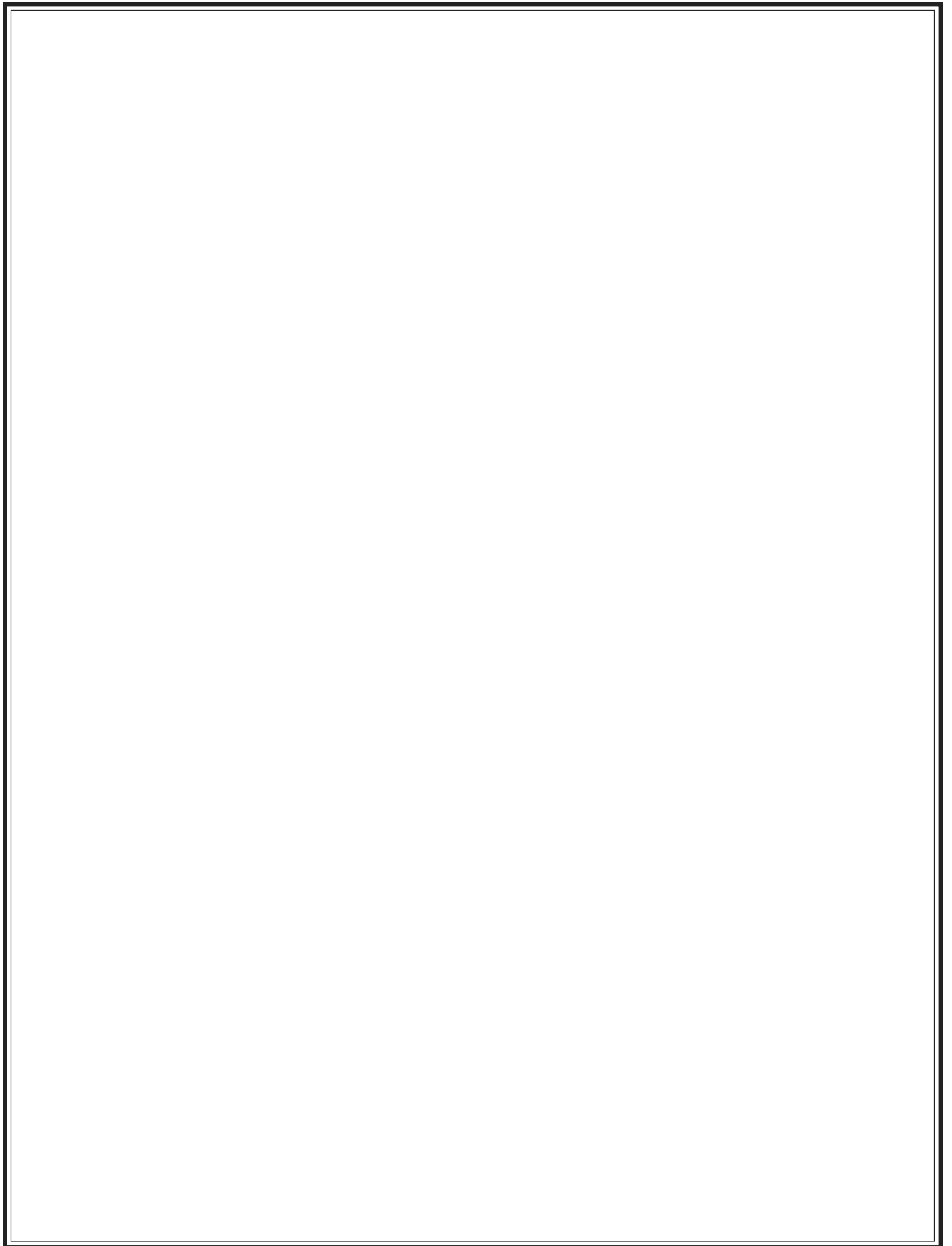

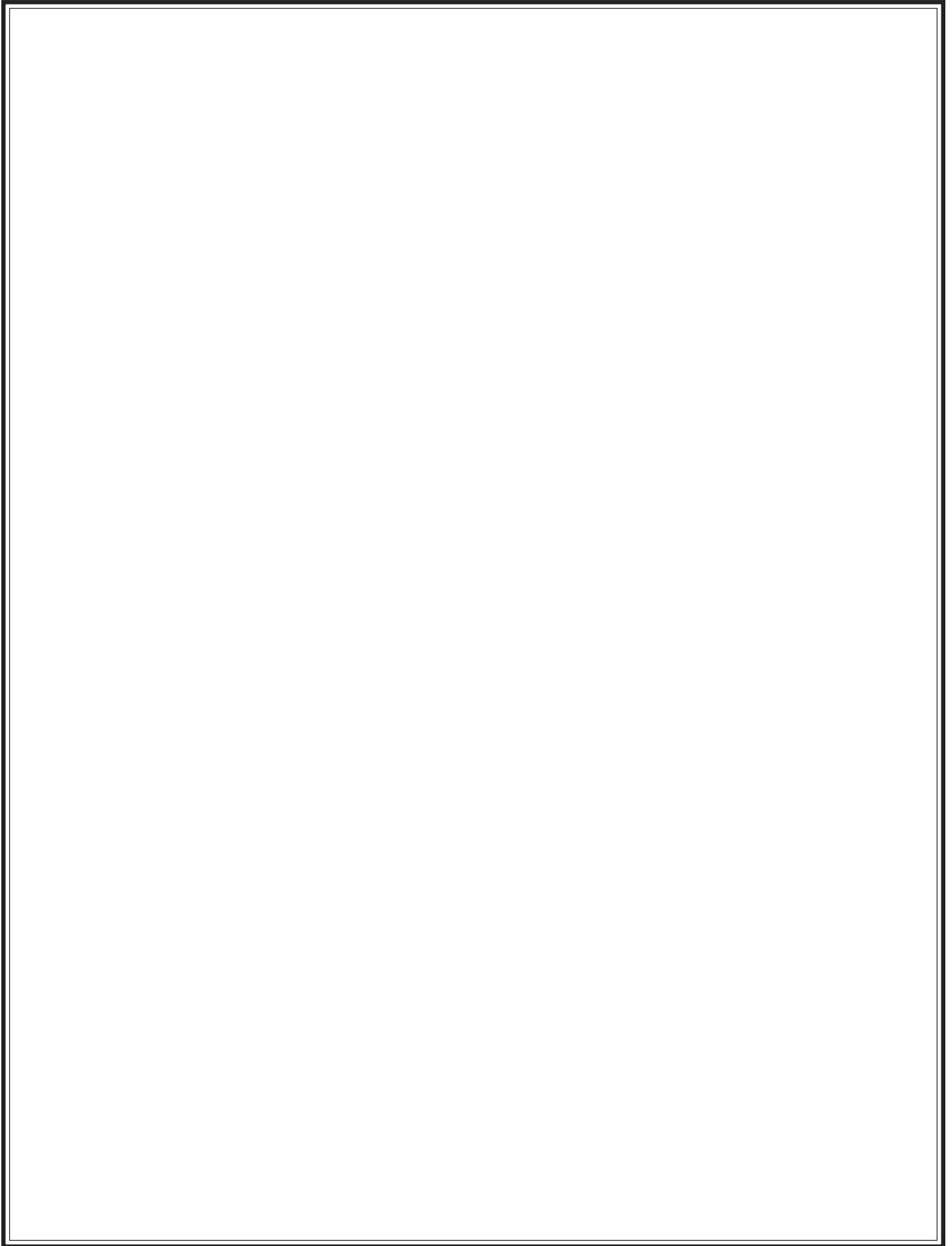

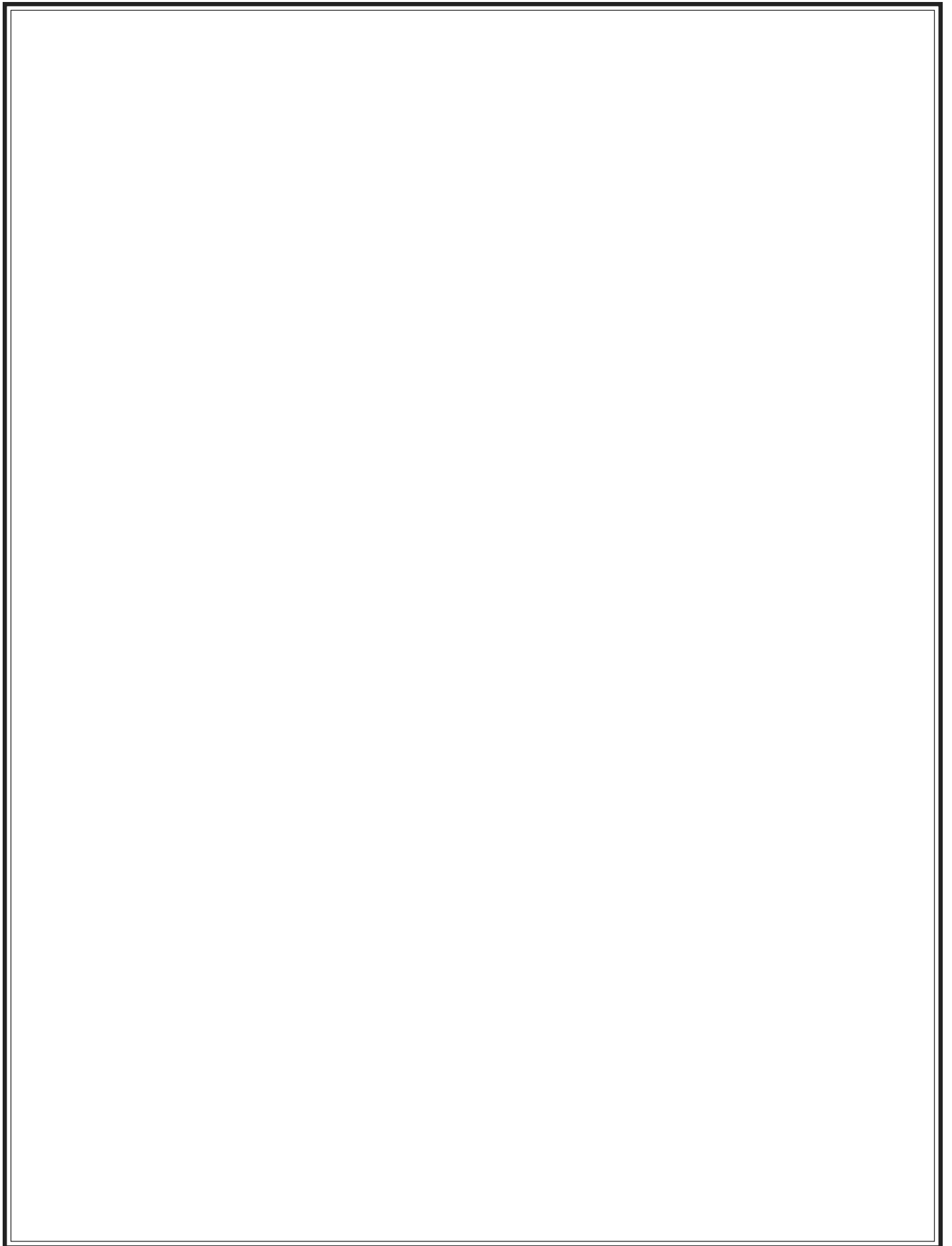

**CALIFORNIA PROPOSITION 65 WARNING:  
Operation of this equipment and/or engine  
exhaust from this product contains chemicals  
known to the State of California to cause cancer,  
birth defects, or other reproductive harm.**



*Bred Tough. Technology Born to Work.  
The Way It Ought To Be.*

Stone Construction Equipment, Inc.  
P.O. Box 150, Honeoye, New York 14471  
Phone: (800) 888-9926  
Fax: 716-229-2363  
e-mail: [sceny@mcimail.com](mailto:sceny@mcimail.com)  
[www: stone-equip.com](http://www.stone-equip.com)

A 100% employee-owned American manufacturer

© 1984 Stone Construction Equipment, Inc.  
Printed in U.S.A.