



OPERATOR MANUAL

MODELS: RP522 & RP652



REVERSIBLE PLATE

A 100% employee-owned American manufacturer

TABLE of CONTENTS

RP522 & RP652

FOREWORD	5
LIMITED WARRANTY	6
SECTION 1 - TECHNICAL DATA	7 - 10
1.1 Specifications	8 - 9
1.2 Noise and Vibration Data	10
SECTION 2 - HEALTH & SAFETY	11 - 16
SECTION 3 - OPERATION	17 - 23
3.1 General Information	18
3.2 Description	18
3.3 Normal Use	18
3.4 Improper Use	18
3.5 Who Is Allowed To Operate The Machine?	19
3.6 Conversions and Modifications To The Machine	19
3.7 Safety Information In The Operating and Maintenance Instructions	19
3.8 Transporting The Machine	19
3.9 Before Starting Operations	19
3.10 Starting The Machine	20
3.11 Starting In Enclosed Spaces, Tunnels, Mines or Deep Ditches	20
3.12 Machine Control	20
3.13 Parking The Machine	20
3.14 Filling Gasoline	20
3.15 Operating Control At The Tow-Bar	21
3.16 Adjusting The Tow-Bar	21
3.17 To Start The Engine	22
3.18 Operation	22
3.19 To Stop The Engine	22
3.20 Loading and Transportation	23
SECTION 4 - MAINTENANCE	25 - 34
4.1 Maintenance and Repairs	26
4.2 Testing	26
4.3 General Notes	26 - 27
4.4 Maintenance Work (Honda Engine)	27
4.5 Filling Up With Fuel	27
4.6 Checking The Engine Oil Level	27

TABLE of CONTENTS

RP522 & RP652

4.7	Cleaning The Air Filter Element	28
4.8	Cleaning The Machine	28
4.9	Screw Connections	28
4.10	Checking Rubber Buffer	28
4.11	Checking The V-Belt	28 - 29
4.12	Exciter: Oil Level/Oil Change	29
4.13	Filling and Bleeding The Circuit	29 - 30
4.14	Maintenance Schedule	31
4.15	Lubrication Schedule	32
4.16	Alternative Lube Oil Table	32
4.17	Torque Information and Charts	33 - 34

CALIFORNIA PROPOSITION 65 WARNING 35ij9

FOREWORD

These instructions include:

- Safety regulations
- Operating instructions
- Maintenance instructions

These instructions have been prepared for operation on the construction site and for the maintenance engineer.

These instructions are intended to simplify operation of the machine and to avoid malfunctions through improper operation.

Observing the maintenance instructions will increase the reliability and service life of the machine when used on the construction site and reduce repair costs and downtimes.

Always keep these instructions at the place of use of the machine.

Only operate the machine as instructed and follow these instructions.

Observe the safety regulations as well as the guidelines of the civil engineering trade association. Observe the safety rules for the operation of road rollers and compactors and the pertinent regulations for the prevention of accidents.

Stone Construction Equipment, Inc. is not liable for the function of the machine when used in an improper manner or for other than the intended purpose.

Operating errors, improper maintenance and the use of incorrect operating materials are not covered by the warranty.

The above information does not extend the warranty and liability conditions of business of Stone Construction Equipment, Inc.

Warranty Information

Please enter the following data. This will help expedite any service or warranty work.

1. Machine Type: _____

Machine S/N: _____

2. Engine Type: _____

Engine S/N: _____

3. VIN: _____

4. Purchase Date: _____

5. Dealer/Distributor Information:

Name: _____

Address: _____

Phone #: _____

Fax #: _____

Location of above information:

1. Information on S/N tag.
2. Information on engine tag.
3. Information on S/N tag - if applicable.
4. Date you purchased machine.
5. Dealer machine was purchased from.

Stone Construction Equipment, Inc.
P.O. Box 150, Honeoye, New York 14471
Phone: (800) 888-9926
Fax: (716) 229-2363

Limited Warranty

The Manufacturer warrants that products manufactured shall be free from defects in material and workmanship that develop under normal use for a period of 90 days for concrete vibrators and electric pumps, one year for Rhino®, Bulldog®, Wolfpac Rollers™, trowels, Stompers®, saws, forward plates, engine powered pumps, and 6 months for all other products from the date of shipment. The foregoing shall be the exclusive remedy of the buyer and the exclusive liability of the Manufacturer. Our warranty excludes normal replaceable wear items, i.e. gaskets, wear plates, seals, O-rings, V-belts, drive chains, clutches, etc. Any equipment, part or product which is furnished by the Manufacturer but manufactured by another, bears only the warranty given by such other manufacturer. (The Manufacturer extends the warranty period to "Lifetime" for the drum bearings and seals for the mortar mixers, and agrees to furnish, free of charge, the bearings and seals only upon receipt of the defective parts. The warranty is two years for eccentric bearings on the forward plate compactors, mortar and plaster mixer drums, trowel gearboxes and five years on the Bulldog trench roller eccentric bearings.) A Warranty Evaluation Form must accompany all defective parts. Warranty is voided by product abuse, alterations, and use of equipment in applications for which it was not intended, use of non-manufacturer parts, or failure to follow documented service instructions. The foregoing warranty is exclusive of all other warranties whether written or oral, expressed or implied. No warranty of merchantability or fitness for a particular purpose shall apply. The agents, dealer and employees of Manufacturer are not authorized to make modification to this warranty, or additional warranties binding on Manufacturer. Therefore, additional statements, whether oral or written, do not constitute warranty and should not be relied upon.

The Manufacturer's sole responsibility for any breach of the foregoing provision of this contract, with respect to any product or part not conforming to the Warranty or the description herein contained, is at its option (a) to repair, replace or refund such product or parts upon the prepaid return thereof to location designated specifically by the Manufacturer. Product returns not shipped prepaid or on an economical transportation basis will be refused (b) as an alternative to the foregoing modes of settlement - the Manufacturer's dealer to repair defective units with reimbursement for expenses, except labor, and be reviewed with the Manufacturer prior to repair. A Warranty Evaluation Form must accompany all warranty claims.

Except as set forth hereinabove and without limitation of the above, there are no warranties or other affirmations which extends beyond the description of the products and the fact hereof, or as to operational efficiency, product reliability or maintainability or compatibility with products furnished by others. In no event whether as a result of breach of contract or warranty or alleged negligence, shall the Manufacturer be liable for special or consequential damages including but not limited to: Loss of profits or revenues, loss of use of the product or any associated product, cost of capital, cost of substitute products, facilities or services or claims of customers.

No claim will be allowed for products lost or damaged in transit. Such claims should be filed with the carrier within fifteen days.

Effective April 1, 1998.



Stone Construction Equipment, Inc.
32 East Main Street, P. O. Box 150
Honeoye, NY 14471-0150

Phone: 1-800-888-9926 • 1-716-229-5141
Fax: 1-716-229-2363
www.stone-equip.com • e-mail: sceny@mcimail.com

1. TECHNICAL DATA

1. TECHNICAL DATA

1.1 MACHINE SPECIFICATIONS

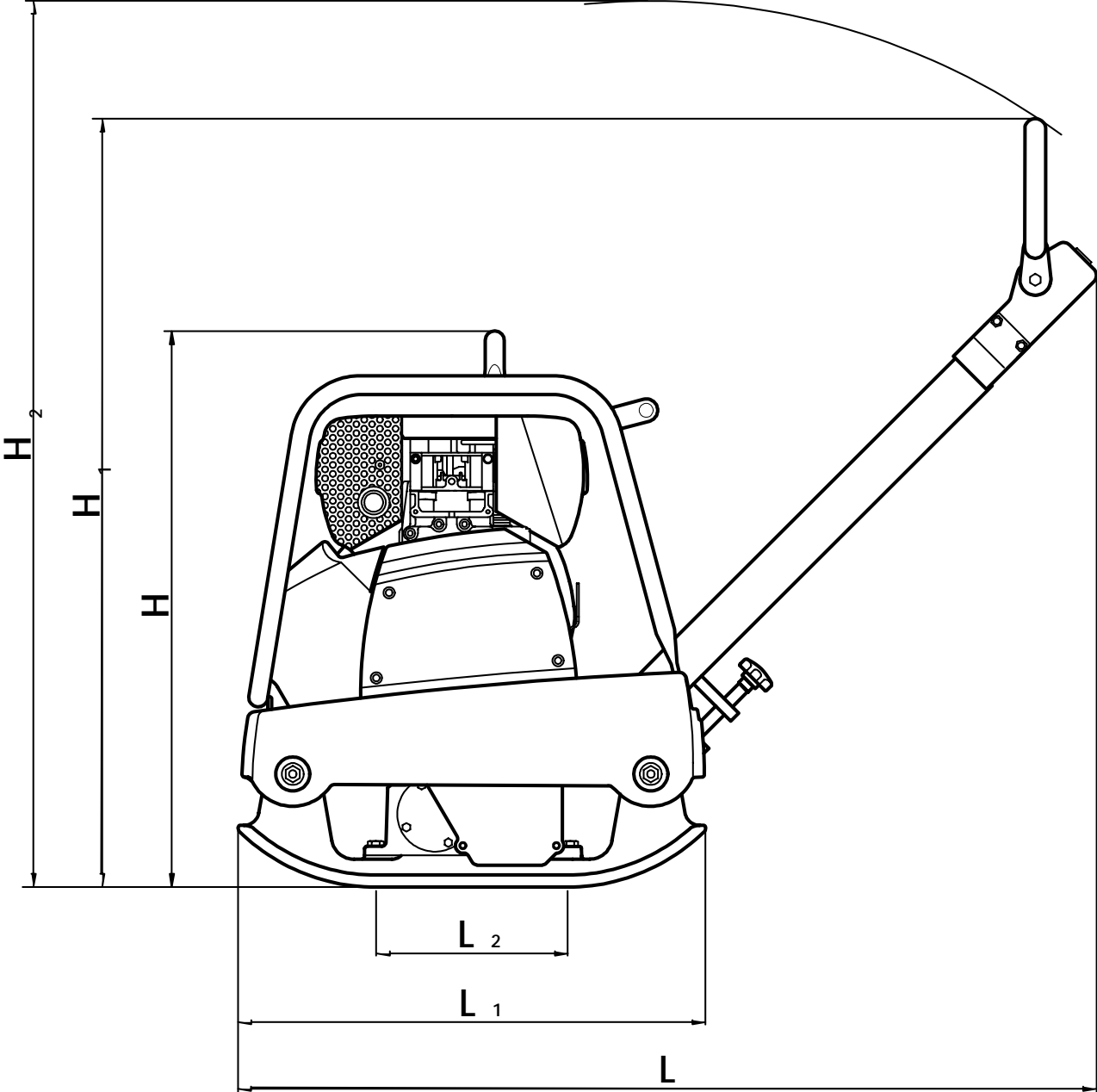



1.1 Specifications - Stone RP522 & RP652

	RP522	RP652
Dimensions in in / mm		
Length L	44.88 in / 1140 mm	44.88 in / 1140 mm
Length L1	23.62 in / 600 mm	27.56 in / 700 mm
Length L2	10.0 in / 254 mm	12.99 in / 330 mm
Height H	24.01 in / 610 mm	29.13 in / 740 mm
Height H1	40.16 in / 1020 mm	40.16 in / 1020 mm
Height H2	46.46 in / 1180 mm	46.46 in / 1180 mm
Width basic unit I	15.75 in / 400 mm	19.69 in / 500 mm
Width basic unit II	15.75 in / 400 mm	27.56 in / 700 mm
Weights in lbs / kg		
Basic unit I	220.5 lbs / 100 kg	407.9 lbs / 185 kg
Basic unit II	220.5 lbs / 100 kg	429.9 lbs / 195 kg
Drive		
Engine Type	Honda GX 120	Honda GX270
Type of Construction	1 cyl. 4-stroke-gasoline	1 cyl. 4-stroke-gasoline
Performance HP / kW	4.0 HP / 2.9 kW	9.0 HP / 6.6 kW
At Revolutions (min ⁻¹)	3600	3600
Cooling	Air	Air
Fuel Consumption (g/h / l/h)	.237 g/h / 0,9 l/h	.55 g/h / 2,1 l/h
Max. Gradient	20°	20°
Max. Gradeability	35%	35%
Drive	via centrifugal clutch and v-belt	via centrifugal clutch and v-belt
Control Fwd/Rvs	hydraulic	hydraulic
Operating Speed in ft/min / m/min		
Basic unit I	0 - 82 ft/min / 0 - 25 m/min	0 - 72 ft/min / 0 - 22 m/min
Basic unit II	0 - 82 ft/min / 0 - 25 m/min	0 - 62 ft/min / 0 - 19 m/min
Vibration		
Centrifugal Force (lbs / kN)	4947 lbs / 22 kN	6519 lbs / 29 kN
Vibration Frequency (vpm / Hz)	5880 vpm / 98 Hz	5700 vpm / 95 Hz
Amplitude (in / mm)	.047 in / 1.2 mm	.047 in / 1.2 mm
Maximum Performance in sq/ft/hr / m²/hr		
Basic unit I	6456 sq/ft/hr / 600 m ² /hr	7101 sq/ft/hr / 660 m ² /hr
Basic Unit II	6456 sq/ft/hr / 600 m ² /hr	8606 sq/ft/hr / 800 m ² /hr
Filling Quantities in gal / l		
Fuel	.66 gal / 2.5 l	1.58 gal / 6.0 l
Optional Extras		
Vulkollan Plate	X	X

1. TECHNICAL DATA

Noise & Vibration Data / Torque Information

1.2 NOISE AND VIBRATION DATA

The following listed noise and vibration data according to the EC machine directive in the version (91/368/EEC) was determined at the rated speed of the drive motor with vibration with the machine placed on a resilient base.

Values can deviate in normal use depending on the conditions prevailing at the place of use.

NOISE DATA

The noise emission specified in appendix 1, subclause 1.7.4.f of the EC machine directive for

	the sound pressure level at the operator place L_{PA}	the sound power level L_{WA}
RP522	97,3 dB(A)	111,7 dB(A)
RP652	92,3 dB(A)	109,3 dB(A)

These noise levels were measured according to ISO 3744 for the sound power level (L_{WA}) and ISO 6081 for the sound pressure level (L_{PA}) at the operator workplace.



Since the permissible noise rating level of 89 dB(A) can be exceeded with this machine, the operator must wear suitable hearing protection.

VIBRATION DATA

Hand-arm vibration values according to appendix 1, subclause 3.6.3.a of the EC machine directive.

The weighted effective value of acceleration, determination according to ISO 8662, part 1, is about 10 m/s².

2. HEALTH & SAFETY

SAFETY USE

These machines are designed to carry out the function of compacting material of the non-cohesive, bituminous and granular varieties.

If used correctly they will provide an effective and safe means of compaction and meet the appropriate performance standards.

It is essential that the driver/operator of the machine is adequately trained in its safe operation, be authorized to drive it, and have sufficient knowledge of the machine to ensure that it is in full working order before being put to use.

2. HEALTH & SAFETY

Safety Precautions

SAFETY PRECAUTIONS

Before using this equipment, study this entire manual to become familiar with its operation. Do not allow untrained or unauthorized personnel, especially children, to operate this equipment. Use only factory authorized parts for service.

When warning decals are destroyed or missing, contact the Manufacturer immediately at 1-800-888-9926 for replacement. For the safety of yourself and others, it is imperative that the following rules are observed. Failure to do so may result in serious injury or death.

FOLLOW SAFETY INSTRUCTIONS

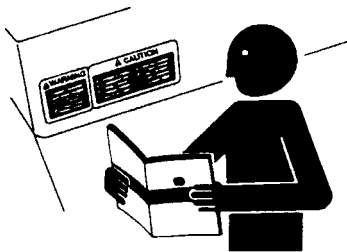

- Carefully read all safety messages and decals in this manual and on your machine safety signs. Keep decals in good condition. Replace missing or damaged decals. Be sure new equipment components and repair parts include the current safety signs. Replacement safety signs and decals are available through your dealer.
- Learn how to operate the machine and how to use controls properly. Do not let anyone operate without instruction.
- Keep your machine in proper working condition. Unauthorized modifications to the machine may impair the function and/or safety and affect machine life.
- If you do not understand any part of this manual and need assistance, contact your dealer.

UNDERSTAND SIGNAL WORDS

▲ DANGER

▲ WARNING

▲ CAUTION

- A signal word – DANGER, WARNING, or CAUTION – is used with the safety-alert symbol. DANGER identifies the most serious hazards.
- DANGER or WARNING safety signs are located near specific hazards.
- General precautions are listed on CAUTION safety signs. CAUTION also calls attention to safety messages in this manual.



- This notation appears before warnings in the text. It means that the step which follows must be carried out to avoid the possibility of personal injury or death. These warnings are intended to help the technician avoid any potential hazards encountered in the normal service procedures. We strongly recommend that the reader takes advantage of the information provided to prevent personal injury or injury to others.

2. HEALTH & SAFETY

Safety Precautions



USE COMMON SENSE WHEN HANDLING FUELS

- Transport and handle fuel only when contained in approved safety container.
- Do not smoke when refueling or during any other fuel handling operation.
- Do not refuel while the engine is running or while it is still hot.
- If fuel is spilled during refueling, wipe it off from the engine immediately and discard the rag in a safe place.
- Do not operate the equipment if fuel or oil leaks exist - repair immediately.
- Never operate this equipment in an explosive atmosphere.



- Keep feet clear of all plates.
- Keep work area free of bystanders.
- For foot protection, wear steel toe shoes or toe pads.



- Ear protection required when operating this equipment.



HOT SURFACES

- Muffler, engine, and engine shroud may be hot.
- Allow all components in the engine compartment to cool before performing any service work.



- Never operate unit in a poorly ventilated or enclosed area.
- Avoid prolonged breathing of exhaust gases.
- Engine exhaust fumes can cause sickness or death.

2. HEALTH & SAFETY

Safety Precautions

WEAR PROTECTIVE CLOTHING

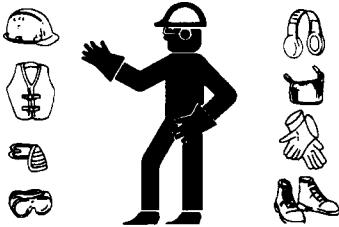

- Wear close fitting clothing and safety equipment appropriate to the job.
- Prolonged exposure to loud noise can cause impairment or loss of hearing.
- Wear a suitable hearing protective device such as earmuffs or earplugs to protect against objectionable or uncomfortable loud noises.
- Operating equipment safely requires the full attention of the operator. Do not wear radio or music headphones while operating machine.

PRACTICE SAFE MAINTENANCE



- Understand service procedure before doing work. Keep area clean and dry.
- Never lubricate, service or adjust machine while it is moving. Keep hands, feet, and clothing from power-driven parts. Disengage all power and operate controls to relieve pressure. Lower equipment to the ground. Stop the engine. Remove the key. Allow machine to cool.
- Securely support any machine elements that must be raised for service work.
- Keep all parts in good condition and properly installed. Fix damage immediately. Replace worn or broken parts. Remove any buildup of grease, oil, or debris.
- Disconnect battery ground cable (-) before making adjustments on electrical systems or welding on machine.

PREPARE FOR EMERGENCIES

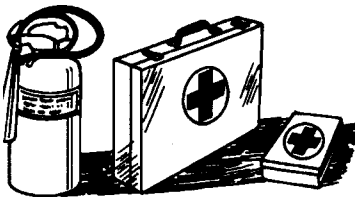

- Be prepared if a fire starts.
- Keep a first aid kit and fire extinguisher handy.
- Keep emergency numbers for doctors, ambulance service, hospital, and fire department near your telephone.

2. HEALTH & SAFETY

Safety Precautions



- Starting fluid (ether) is highly flammable, do not use or an explosion or fire may result.



PREVENT BYPASS STARTING

- Avoid possible injury or death from engine runaway.
- Do not start engine by shorting across starter terminal.
- Start engine only from operator's station.

DISPOSE OF WASTE PROPERLY

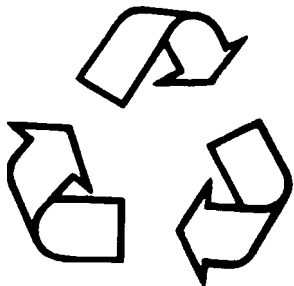

- Improperly disposing of waste can threaten the environment and ecology. Potentially harmful waste used with equipment include such items as oil, fuel, coolant, brake fluid, filters, and batteries.
- Use leakproof containers when draining fluids. Do not use food or beverage containers that may mislead someone into drinking from them.
- Do not pour waste onto the ground, down a drain, or into any water source.
- Inquire on the proper way to recycle or dispose of waste from your local environmental or recycling center.

3. OPERATION

3. OPERATION

RP522 & RP652

3.1 GENERAL INFORMATION

This machine has been built according to the state-of-the-art in compliance with the pertinent rules. Nevertheless, these machines can still constitute a hazard to persons and property if:

- Not used for the intended purpose.
- Not operated by suitably qualified and instructed personnel.
- Modified or converted in an improper manner.
- The pertinent safety regulations are not observed.

For this reason, any person entrusted with the operation, maintenance, or repair of the machine is obligated to read and follow the operating instructions and particularly to observe the safety regulations.

If necessary, this must be confirmed by the signature of the company using the machine.

Furthermore, the following must be made known and observed:

- Pertinent regulations for the prevention of accidents.
- Generally recognized safety rules.
- Country-specific regulations.

3.2 DESCRIPTION

The RP522 and RP652 are reversible vibrating plates operating on the basis of the twin-shaft vibration system principle.

The engine drives the exciter on the baseplate via a centrifugal clutch and a V-belt. The exciter produces the vibration required for compaction as a result of the built-in imbalance.

The machine is guided at the tow-bar grip. It is operated with the operating controls on the tow-bar.

TAKE GREAT CARE ON DOWNSLOPES. THE MACHINE COULD SLIP DUE TO LOOSE MATERIAL OR IF THE SURFACE IS SLIPPERY. DO NOT WORK ON HARD CONCRETE OR SET ASPHALT SURFACING.

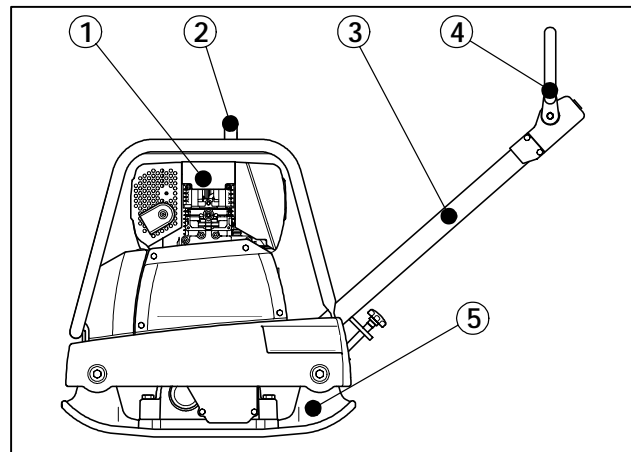

Equipment Overview

1. Engine
2. Central point suspension
3. Tow-bar
4. Operating control/tow-bar
5. Base plate with exciter

3.3 NORMAL USE

This machine is only intended for all compaction work in the fields of Civil Engineering and Road Construction.

All ground materials such as sand, gravel, sludge, crushed stone, asphalt, and composite set paving can be compacted.

3.4 IMPROPER USE

The machine can constitute hazards if not used by instructed personnel or for other than the intended purpose. The machine is not to be used on hard concrete, hardened bituminous surfacing or frozen soil.

3. OPERATION

RP522 & RP652

3.5 WHO IS ALLOWED TO OPERATE THE MACHINE?

Only suitably qualified, instructed, and authorized persons over 18 years of age may operate the machine. Maintenance and repairs, particularly on the hydraulic system, require special knowledge and must be undertaken only by qualified personnel.

3.6 CONVERSIONS AND MODIFICATIONS TO THE MACHINE

Unauthorized modifications and conversion of the machine are not permitted for safety reasons.

Spare parts and special equipment not delivered by us are also not approved by us. The installation and/or the use of such parts can also have a detrimental effect on the operating safety.

The manufacturer disclaims all liability for any damage resulting from the use of non-original parts or special equipment.

3.7 SAFETY INFORMATION IN THE OPERATING AND MAINTENANCE INSTRUCTIONS

The following signs and designations are used in the manual to designate instructions of particular importance:

Important - Refers to special information on how to use the machine most efficiently.

Attention - Refers to special information and/or orders and prohibitions directed towards preventing damage.

⚠ WARNING Refers to orders and prohibitions designed to prevent injury or extensive damage.

3.8 TRANSPORTING THE MACHINE

Only load and transport the machine as specified in the operating instructions.

Only use suitable means of transport and lifting gear with sufficient bearing capacity.

Attach suitable slinging means to the points of attachment provided.

Only use sturdy loading ramps with sufficient bearing capacity. The ramp inclination must be flatter than the gradient climbing ability of the machine.

Secure the machine to prevent it from tilting or slipping.

It is highly dangerous to walk or stand under suspended loads.

Secure the machine on transport vehicles to prevent it from rolling, slipping, and tilting.

3.9 BEFORE STARTING OPERATIONS

⚠ WARNING

WEAR PERSONAL PROTECTIVE EQUIPMENT TO PREVENT LOSS OF HEARING. OBSERVE THE SAFETY REGULATIONS. OBSERVE THE OPERATING AND MAINTENANCE INSTRUCTIONS. BEFORE PUTTING THE MACHINE INTO SERVICE, PLEASE READ THE OPERATING MANUAL FOR THE ENGINE.

- Park the machine on level ground.
- Check the engine oil level.
- Check the fuel level.
- Top off missing lubricants according to the lubricant chart.
- Check screw connections for tightness.
- Check condition of engine and machine.

3. OPERATION

RP522 & RP652

3.10 STARTING THE MACHINE

Prior to starting, familiarize yourself with the operating and control elements, the mode of operation of the machine, and the working environment. This includes, e.g. obstacles in the working area, bearing capacity of the ground, and the necessary safety provisions.

Use personal protective equipment (safety footwear, hearing protection, etc.).

Check to ensure that all safety devices are firmly in place.

Do not start the machine if instruments or control devices are faulty.

For machines with hand-start, only use the safety cranks tested by the manufacturer, and precisely follow the operating instructions of the engine manufacturer.

Precisely follow the starting and stopping procedures specified in the operating instructions and observe indicator lights.

Starting and operation of the machine in potentially explosive atmospheres is forbidden!

3.11 STARTING IN ENCLOSED SPACES, TUNNELS, MINES OR DEEP DITCHES

Engine exhaust fumes are highly dangerous!

For this reason, when operating the machine in enclosed spaces, tunnels, mines or deep ditches, it is important to ensure that there is sufficient air to breathe (see UVV "Construction Work", VBG 37, paragraphs 40 and 41).

3.12 MACHINE CONTROL

Operating devices that adjust themselves automatically when released in normal use must not be locked.

Check protective devices and brakes for proper functioning prior to operation.

When reversing, particularly on the edges and banks of ditches, as well as in front of obstacles, the machine operator can fall or be crushed.

Always keep a safe distance away from the edges and banks of ditches and refrain from any actions that could cause the machine to topple over.

Always control the machine so that hand injuries through hard objects are avoided.

Always ascend slopes carefully in a direct path.

Reverse up steep slopes to prevent the machine from toppling over onto the machine operator.

If faults on the safety devices or other faults detrimental to the safe operation of the machine are noticed, operation of the machine must be stopped immediately and the faults remedied.

When undertaking compaction work in the vicinity of buildings or above pipelines and similar, check the effect of the vibrations on the buildings and pipes and stop compaction work if necessary.

3.13 PARKING THE MACHINE

Park the machine on a firm and level surface.

Shut down the drive and secure it to prevent accidental movement and unauthorized use. If available, close the fuel valve. Do not place or store equipment with integrated moving gear on the chassis. The moving gear is intended only for transportation purposes.

3.14 FILLING GASOLINE

Only fill gasoline with the engine shut down. No open fire, do not smoke. Do not spill any fuel. Collect discharging fuel in a suitable container and prevent fuel from seeping into the soil. Ensure that the filler cap is tight.

Leaky fuel tanks constitute an explosion hazard and must therefore be replaced immediately.

3. OPERATION

RP522 & RP652

3.15 OPERATING CONTROL AT THE TOW-BAR

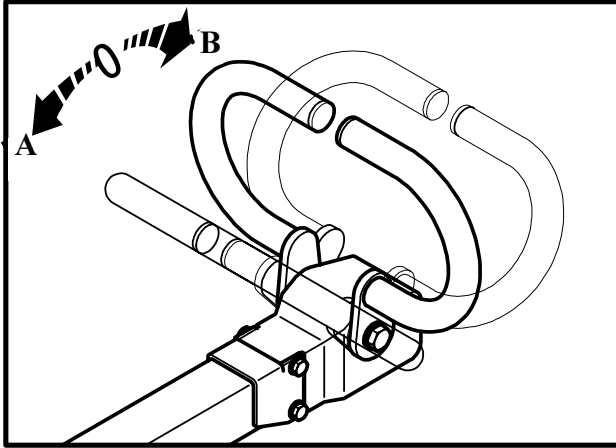

A forward
B reverse

The control lever serves for adjustment of the unbalances in the exciter and in turn for continuous regulation.

- Forward (A), point compacting (0), reverse (B)
- The speed of the machine

Important - The control lever remains automatically in position only when set to the maximum forward travel setting (a). In any other position, the control lever moves in the direction of maximum forward travel when released. If the control lever is operated too quickly several times, the shift lever will block in reverse travel. In this case:

- Release lever in forward travel position up to maximum forward travel position.
- Blocking is cleared within a few seconds and perfect shifting is possible.

The control lever can be operated only with the engine running. The lever blocks if operated when the machine is stationary. Blocking is immediately cleared when the engine is restarted.

3.16 ADJUSTING THE TOW-BAR

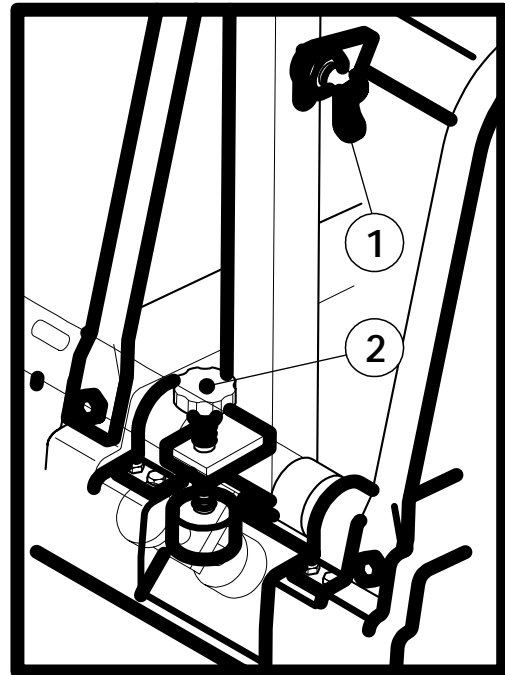

By turning the adjustment-screw (2), the tow-bar can be set to any position so as to obtain the best working height on the tow-bar grip.

In case of loading and transporting, the tow-bar has to be locked in an upright position by turning up the locking bolt.

When loading and transporting, the tow-bar must be locked vertical by moving the latch (1).

3. OPERATION

RP522 & RP652

3.17 TO START THE ENGINE

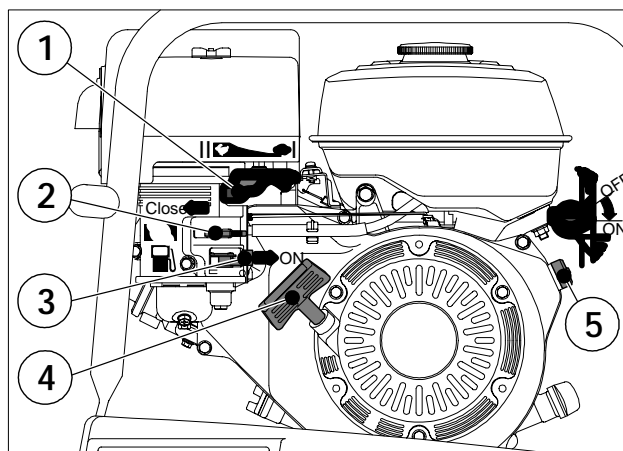

Important - To prevent engine damage through oil deficiency, the engine is provided with a low oil warning system. If the oil level is too low, the engine switches off automatically (the engine switch remains in the ON position).

1. Move fuel tap (3) to “ON”.
2. Move choke lever (2) to “CLOSE”.
3. Adjust engine speed control lever (1) to full load.
4. Move engine switch (5) to “ON”.
5. Pull starter handle (4) slightly until a resistance is felt, then pull out sharply.
6. Allow engine to warm up for one to two minutes.
7. As the engine warms up, gradually move the choke lever to the “OPEN” position.

Attention - Do not allow starter handle to rebound against the engine. Guide starter cable back by hand to the rest position. Do not operate choke lever if engine is warm or at high outside temperature.

3.18 OPERATION

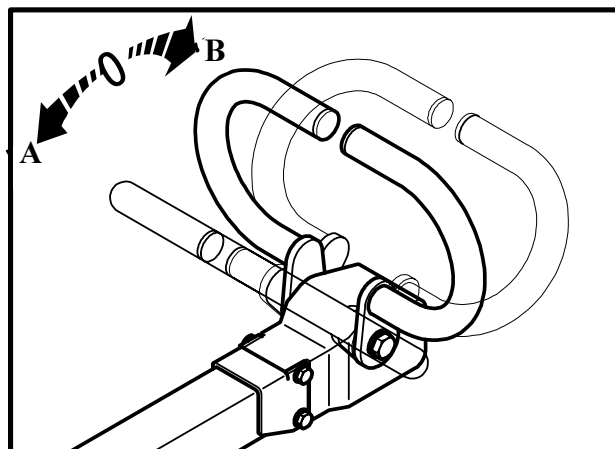

- Allow the engine to warm up for one to two minutes when idling.
- Adjust the engine speed control lever to full load position.

Attention - The engine speed should always be well below or well above the engaging speed of the centrifugal clutch* since, otherwise, the clutch linings will wear very quickly or could even be destroyed.

*ca. 2000 1/min

- Adjust the direction of travel and speed at the control lever.
- Guide and steer the machine at the control arm.

3.19 TO STOP THE ENGINE

1. Adjust engine speed control lever (1) to idle position.
2. Turn engine switch (4; E-Start 6) to “OFF”.
3. Move fuel tap (3) to “OFF”.

Important - In an emergency situation, set the engine switch to the OFF position in order to stop the engine.

3. OPERATION

RP522 & RP652

3.20 LOADING AND TRANSPORTATION

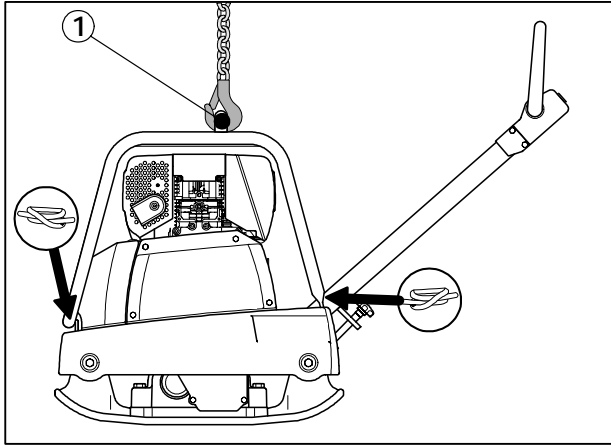

⚠️ WARNING

ONLY USE SUFFICIENTLY STRONG AND SECURE LOADING RAMPS WHEN LOADING. SECURE THE MACHINE AGAINST ROLLING OR SLIPPING OFF AND AGAINST TIPPING OVER. ENSURE THAT PERSONS ARE NOT PUT AT RISK. ALWAYS USE THE FASTENING POINTS PROVIDED WHEN LOADING, LASHING, OR LIFTING THE MACHINE. NEVER STAND OR WALK UNDER SUSPENDED LOADS. THIS IS EXTREMELY DANGEROUS!

After being loaded, the machine should be:

1. Lashed in place (1).
2. Lock the tow-bar.
3. Use the center-of-gravity suspension point (2) in order to lift the machine.

4. MAINTENANCE

4. MAINTENANCE

RP522 & RP652

4.1 MAINTENANCE AND REPAIRS

Observe the maintenance, inspection and adjustments, and intervals specified in the operating instructions, as well as the information for part replacement.

Maintenance work must be undertaken by only qualified and authorized persons.

Maintenance and repairs must only be undertaken with the drive stationary.

Only carry out maintenance and repairs when machine is parked on a firm and even surface and is secured to prevent it from rolling.

When changing larger assemblies and individual components, only use suitable and perfectly functioning hoisting and lifting gear with suitable bearing capacity. Attach and secure parts to lifting gear carefully.

Spare parts must comply with the technical requirements of the manufacturer. Therefore only use original spare parts.

Before working on hydraulic lines, these must previously be rendered pressureless. Hydraulic oil discharging under pressure can cause serious injuries.

Only persons with a special knowledge of hydraulics and the necessary experience must undertake work on hydraulic devices.

Do not adjust pressure relief valves.

Drain hydraulic oil at operating temperature.

Caution: Risk of scalding!

Collect discharging hydraulic oil and dispose of the same in an environmentally-friendly manner.

Do not start the engine with hydraulic oil drained.

After completing all work (with the system still pressureless), inspect all connections and bolted connections for leaks.

Inspect all hoses and bolted connections for leaks and externally visible damage at regular intervals. Rectify any damage immediately.

Replace externally damaged hydraulic hose lines at regular intervals (depending on time used), even when no safety-relevant faults are visible.

Inspect the electrical equipment of the machine at regular intervals. Faults such as loose connections or worn/scorched cables must be repaired immediately.

Properly refit and inspect all protective devices after maintenance and repairs.

4.2 TESTING

Road rollers, trench rollers, and vibrating plates must be tested for safety by an expert depending on the particular application and operating conditions as required, however at least once a year.

4.3 GENERAL NOTES

Careful maintenance:

- Increased service life
- Increased function
- Reduced downtimes
- Increased reliability
- Reduced repair costs

- Observe the safety regulations.
- Maintenance work should only be performed when the engine is shut off.
- The engine and machine should be cleaned thoroughly before carrying out maintenance work.
- Park the machine on a flat surface and secure it against rolling away and slipping.
- Ensure that operating materials and replaced parts are disposed of safely and in an environmentally friendly way.

4. MAINTENANCE

RP522 & RP652

- Before commencing work on any electrical equipment, disconnect the battery and cover it with insulating materials.
- Do not confuse “PLUS” and “MINUS” poles on the battery.
- It is essential that short-circuits be prevented in cables carrying currents.
- Burnt-out light bulbs in indicator lamps should be replaced immediately.
- When cleaning the machine with a high-pressure water jet, do not spray the electrical components directly.
- After washing the components, blow-dry them with compressed air in order to prevent surface leakage current and corrosion.

4.4 MAINTENANCE WORK (HONDA ENGINE)

Attention - Only the maintenance work that has to be performed daily is included in this operating manual. Please refer to the Engine Operating Manual and to the maintenance instructions and intervals listed therein.

4.5 FILLING UP WITH FUEL

WARNING

FILL FUEL TANK ONLY WHEN ENGINE IS SWITCHED OFF. NO NAKED FLAMES. NO SMOKING. NEVER FILL FUEL TANK IN ENCLOSED AREAS.

1. Clean the area around the fuel filling socket.
2. Open the cap and check the fuel level visually.
3. If necessary, fill up with unleaded fuel.

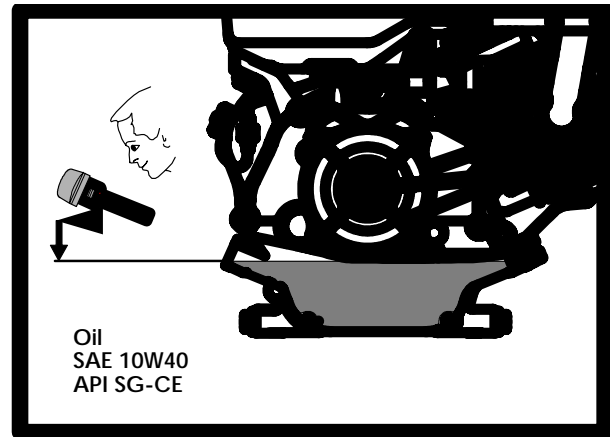

4.6 CHECKING THE ENGINE OIL LEVEL

1. Park the machine horizontally.
2. Clean the area around the oil filler cap.
3. Open the oil filler cap.
4. Check the oil level and refill up to the edge of the oil filler cap if necessary.
5. Check the seal on the dipstick and replace if necessary.
6. Close the oil filler cap.
7. Allow the engine to run for approximately one minute and check oil level again with engine switched off.

4. MAINTENANCE

RP522 & RP652

4.7 CLEANING THE AIR FILTER ELEMENT

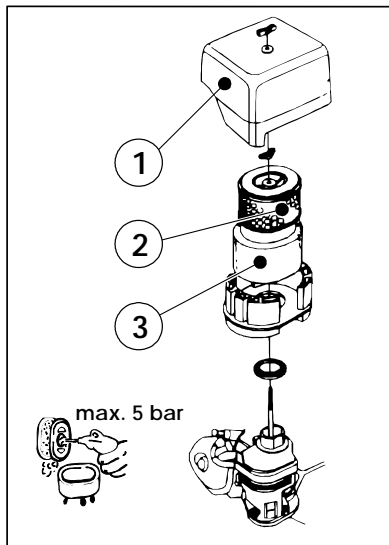

Attention - Never run the engine without the air cleaner. Rapid engine wear will result. Do not allow dust to enter the carburetor.

1. Remove the filter cover (1).
2. Take out the filter element (2 & 3).
3. Check the filter element, replace if damaged.

For slight clogging: Clean the filter element (2) by tapping lightly or blow it from inside to the outside with dry, compressed air.

For heavy clogging: Wash the filter element (3) in a non-flammable cleaning solution and allow to dry thoroughly.

⚠ WARNING

NEVER USE PETROL OR CLEANING SOLUTIONS WITH A LOW FLASH POINT FOR CLEANING THE FILTER ELEMENT. DO NOT SMOKE IN THE WORKING AREA; AVOID OPEN FIRE AND SPARKS – FIRE AND EXPLOSION HAZARD. USE PROPER SAFETY GOGGLES TO AVOID EYE INJURIES.

1. Soak the filter element (3) with clean motor oil, squeeze out excess oil.
2. Replace the filter element (2 & 3).
3. Fit the cover (1) and fasten.

4.8 CLEANING THE MACHINE

Clean the machine thoroughly daily.

Attention - After cleaning, check all cables, hoses, pipes, and screwed fittings for leaks, loose connections, chafe marks, and other damage. Any faults that are detected should be rectified immediately. Do not use any flammable or aggressive substances for cleaning purposes.

4.9 SCREW CONNECTIONS

With vibration equipment, it is important to check the screwed connections periodically to ensure that they are screwed tight. Observe tightening torques.

4.10 CHECKING RUBBER BUFFER

Check the rubber buffer for cracks, fractures, and for a tight fit. Replace immediately if damaged.

4.11 CHECKING THE V-BELT

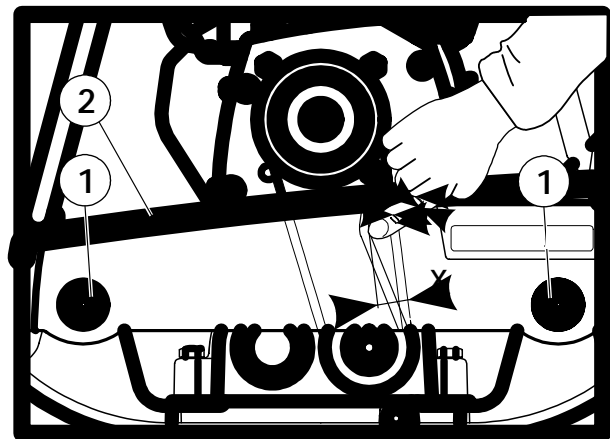

1. Remove the v-belt guard.
2. Check the v-belt for tension and condition. Proper tension is obtained when a two-lb.

4. MAINTENANCE

RP522 & RP652

force is applied midway between the sheaves and a 1/4-1/2 deflection of the belt is obtained

3. Undo the nuts (1) of the rubber stops on the outside.
4. Push the upper tray (2) upwards on both sides.

Important - It is important to ensure that the frame is also actually pushed on the rubber stop contact surfaces and not just the rubber elements are stretched and then spring back again. If necessary apply light blows with a hammer to knock the rubber stops downwards.

1. Both buffers should be equally pre-tensioned.
2. Tighten nuts (1).
3. Crank the drive manually and re-check tension and correct if necessary.
4. Replace v-belt guard.

4.12 EXCITER: OIL LEVEL/OIL CHANGE

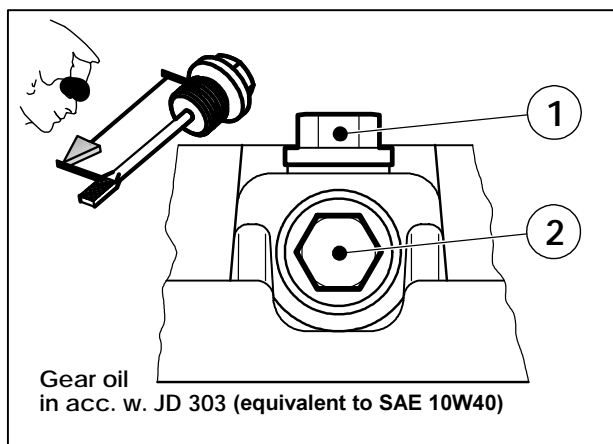

Important - Check/change exciter oil when it is warm.

⚠ WARNING

**TAKE CARE WHEN DRAINING HOT OIL;
DANGER OF SCALDING.**

1. Unscrew oil filling plug (1) and oil drain plug (2).
2. Drain old oil.
3. Replace oil drain plug (2).
4. Fill new oil via oil filler hole (1). See lubrication chart for oil quantity and quality.
5. Replace oil filling plug (1).

Attention - Collect oil that flows out and dispose of oil without harm to the environment. In order to ensure sufficient lubrication, the distance of the oil level must be at the upper dip rod mark (see diagram above). If the oil level is too low, the gear unit can be damaged though overheating.

4.13 FILLING AND BLEEDING THE CIRCUIT

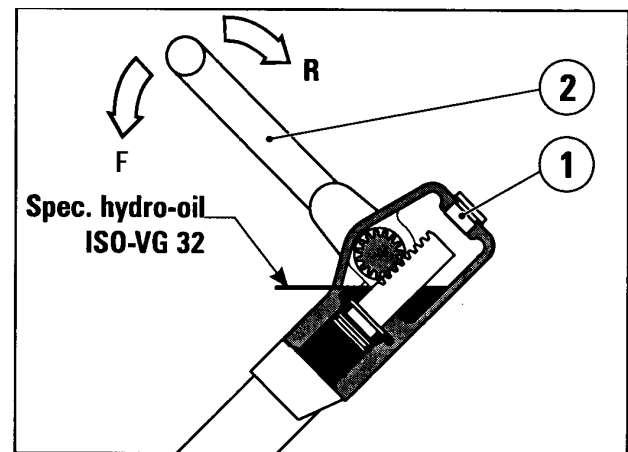

1. Release locking screw (1).
2. Set throttle lever (2) to "F".
3. Pour in hydraulic fluid while continually changing the throttle lever position.

Important - To ensure correct bleeding, from time place the shaft vertically.

4. MAINTENANCE

RP522 & RP652

Stop filling when:

- A distinct “clicking” noise is heard in the exciter while shifting the lever.
- You no longer feel a cushion of air when moving the throttle lever.

Attention - When filling, the circuit path is shortened.

1. To check oil level, start the engine and bring up to operating speed.
2. Move throttle lever several times backward and forwards between “F” and “R”.
3. The correct oil level should be somewhere in the area shown (see illustration). At this point, the throttle lever must be in the “F” position.
4. If the level is too low, top off with hydraulic fluid. If too high, drain off excess fluid.
5. With the machine running and the throttle lever in the “F” position, close locking screw (1).

4. MAINTENANCE

RP522 & RP652

4.14 MAINTENANCE SCHEDULE

Intervals	Daily	20 h	50 h	100 h	250 h	As Required
Clean machine	X					
Check engine oil level *	X					
Change engine oil *		X		X		
Check air filter *	X					
Change air filter * (X 17210 ZE2 822)						X
Check exciter oil level			X			
Change exciter oil (or annually)					X	
Check hydraulic oil level						X
Check V-belt				X		
Retighten screwed connections				X		
Check rubber buffers				X		
Check, adjust the valve clearance *					X	

* Observe the engine manual

4. MAINTENANCE

RP522 & RP652

4.15 LUBRICATION SCHEDULE

Lubrication point	Quantity (qt / l)	Change intervals (operating hours)	Lubrication
Engine			
RP522	.634 qt / 0.6 l	100 *	Engine oil API SG-CE SAE 10W40
RP652	1.162 qt / 1.1 l		
Exciter			
RP522		500 ** or annually	Engine oil API SG-CE SAE 10W40
RP652			
Hydraulic			
RP522		not necessary	Spec. Hydro-Oil ISO-VG32
RP652			

* first time after 20 op. hrs.

** first time after 100 op. hrs.

4.16 ALTERNATIVE LUBE OIL TABLE

	Engine Oil API SG-CE SAE 10W40	Gear oil in acc. with JDM J 20 A	Spec. Hydro-Oil ISO-VG 32	ATF-Oil
DEUTZ OIL	HD-C 10W40; TLL 10W40	GO-SP	Spec. Hydro-Oil W32: H-EP 32 BA**	Dexron III D
ARAL	Multi Turboral	Fluid HGS	-----	Dexron III D
BP	Vanellus Multigr.; Vanellus FE *	Hydromatic TF-SD	Energol EHPM 32	Dexron III D
ESSO	XD 3+LDX; CDX	Torque Fluid 56	Univis N 32	Dexron III D
FINA	Kappa FE; Kappa Turbo DI	Transfluid AS	Hydran TSX 32; Biohydran TMP 32 **	Finamatic II D
SHELL	Super 3	Donax TD	Tellus W32; Naturelle HFE 32 **	Dexron III D
TOTAL	Rubia XT; Rubia FE *	-----	-----	Dexron III D

* semi-synthetic, light-duty oils

** biological multi-purpose hydraulic oils

4. MAINTENANCE

RP522 & RP652

4.17 TORQUE INFORMATION AND CHARTS

The tightness categories relate to bolts with untreated, unlubricated surface.

The figures result in 90% exploitation of the limit of elasticity for a friction coefficient $\mu_{ges} = 0.14$.

Use a torque wrench to check that the tightening torques are observed.

The figures indicated do not apply if lubricant MoS2 is used.

Important - Self-tightened nuts have to be replaced after every disassembly.

SAE GRADE 5 Coarse Thread, Zinc-Plated		
SIZE	TORQUE	
	ft. lbs.	Nm
1/4 - 20 (.250)	6	8
5/16 - 18 (.3125)	13	18
3/8 - 16 (.375)	23	31
7/16 - 14 (.4375)	37	50
1/2 - 13 (.500)	57	77
9/16 - 12 (.5625)	82	111
5/8 - 11 (.625)	112	152
3/4 - 10 (.750)	200	271
7/8 - 9 (.875)	322	436.5
1 - 8 (1.000)	483	655

SAE GRADE 8 Coarse Thread, Zinc-Plated		
SIZE	TORQUE	
	ft. lbs.	Nm
1/4 - 20 (.250)	9	12
5/16 - 18 (.3125)	18	24
3/8 - 16 (.375)	33	45
7/16 - 14 (.4375)	52	70
1/2 - 13 (.500)	80	108
9/16 - 12 (.5625)	115	156
5/8 - 11 (.625)	159	215
3/4 - 10 (.750)	282	382
7/8 - 9 (.875)	454	615
1 - 8 (1.000)	682	925

SAE GRADE 5 Fine Thread, Zinc-Plated		
SIZE	TORQUE	
	ft. lbs.	Nm
1/4 - 28 (.250)	7	10
5/16 - 24 (.3125)	14	19
3/8 - 24 (.375)	26	35
7/16 - 20 (.4375)	41	56
1/2 - 20 (.500)	64	87
9/16 - 18 (.5625)	91	123
5/8 - 18 (.625)	128	173
3/4 - 16 (.750)	223	302
7/8 - 14 (.875)	355	481
1 - 12 (1.000)	529	717
1 - 14 (1.000)	541	733

SAE GRADE 8 Fine Thread, Zinc-Plated		
SIZE	TORQUE	
	ft. lbs.	Nm
1/4 - 28 (.250)	10	14
5/16 - 24 (.3125)	20	27
3/8 - 24 (.375)	37	50
7/16 - 20 (.4375)	58	79
1/2 - 20 (.500)	90	122
9/16 - 18 (.5625)	129	175
5/8 - 18 (.625)	180	244
3/4 - 16 (.750)	315	427
7/8 - 9 (.875)	501	679
1 - 12 (1.000)	746	1011
1 - 14 (1.000)	764	1036

t-chrt_i.doc

4. MAINTENANCE

RP522 & RP652

Property Class 8.8

ZINC-PLATED

SIZE	Coarse Thread		Fine Thread	
	Nm	ft. lbs.	Nm	ft. lbs.
M6	9.9	7	10	7
M8	24	18	25	18
M10	48	35	49	36
M12	83	61	88	65
M14	132	97	140	103
M16	200	148	210	155
M20	390	288	425	313
M24	675	498	720	531

Property Class 10.9

ZINC-PLATED

SIZE	Coarse Thread		Fine Thread	
	Nm	ft. lbs.	Nm	ft. lbs.
M6	14	10	14	10
M8	34	25	35	26
M10	67	49	68	50
M12	117	86	125	92
M14	185	136	192	142
M16	285	210	295	218
M20	550	406	600	443
M24	950	701	1000	738

Property Class 12.9

ZINC-PLATED

SIZE	Coarse Thread		Fine Thread	
	Nm	ft. lbs.	Nm	ft. lbs.
M6	16.5	12	16.5	12
M8	40	30	42	31
M10	81	60	82	60
M12	140	103	150	111
M14	220	162	235	173
M16	340	251	350	258
M20	660	487	720	531
M24	1140	841	1200	885

Conversion Factor: 1 ft. lb. = 1.3558 Nm

CALIFORNIA PROPOSITION 65 WARNING:
Operation of this equipment and/or engine exhaust
from this product contains chemicals known to the
State of California to cause cancer, birth defects,
or other reproductive harm.



Stone Construction Equipment, Inc.
P.O. Box 150, Honeoye, New York 14471
Phone: (800) 888-9926
Fax: 716-229-2363
e-mail: sceny@mcimail.com
www: stone-equip.com

A 100% employee-owned American manufacturer

© 1999 Stone Construction Equipment, Inc.
Printed in U.S.A.

GP1M