

# OPERATION AND PARTS MANUAL



## MODEL QP4TKT SERIES TRASH PUMP (KUBOTA OC95-E4 DIESEL ENGINE)

Revision #0 (03/26/18)



[www.discount-equipment.com](http://www.discount-equipment.com)

THIS MANUAL MUST ACCOMPANY THE EQUIPMENT AT ALL TIMES.

# **Discount Equipment**

Discount-Equipment.com is your online resource for commercial and industrial quality parts and equipment sales.

## **Locations:**

Florida (West Palm Beach): [561-964-4949](tel:561-964-4949)

Outside Florida TOLL FREE: [877-690-3101](tel:877-690-3101)



**Need parts?** Check out our website at [www.discount-equipment.com](http://www.discount-equipment.com)

## **Can't find what you need?**

Click on this link: <http://www.discount-equipment.com/category/5443-parts/> and fill out the request form.

Please have the machine model and serial number available in order to help us get you the correct parts. One of our experienced staff members will get back to you with a quote for the right part that your machine needs.

We sell worldwide for the brands: Genie, Terex, JLG, MultiQuip, Mayco, Toro/Stone, Diamond Products, Magnum, Airman, Mustang, Power Blanket, Nifty Lift, Atlas Copco, Chicago Pneumatic, Allmand Brothers, Essick, Miller Spreader, Skyjack, Lull, Skytrak, Tsurumi, Husquyarna/Target, Whiteman-Concrete/Mortar, Stow-Concrete/Mortar, Baldor, Wacker, Sakai, Snorkel, Upright, Mi-T-M, Sullair, Neal, Basic, Dynapac, MBW, Weber, Bartell, Bennar Newman, Haulotte, Ditch Runner, Blaw-Knox, Himoina, Best, Buddy, Crown, Edco, Wyco, Bomag, Laymor, Terremite, Barreto, EZ Trench, Takeuchi, Basic, Bil-Jax, Curtis, Gehl, Heli, Honda, ICS/PowerGrit, Puckett, Waldon, ASV, IHI, Partner, Imer, Clipper, MMD, Koshin, Rice, Gorman Rupp, CH&E, Cat Pumps, Comet, General Pump, Giant, AMida, Coleman, NAC, Gradall, Square Shooter, Kent, Stanley, Tamco, Toku, Hatz, Kohler, Robin, Wisconsin, Northrock, Oztec, Toker TK, Rol-Air, Small Line, Wanco, Yanmar

 **WARNING** 

**CALIFORNIA — Proposition 65 Warning**

Diesel engine exhaust and some of its constituents are known to the State of California to cause cancer, birth defects and other reproductive harm.

## REPORTING SAFETY DEFECTS

---

If you believe that your vehicle has a defect that could cause a crash or could cause injury or death, you should immediately inform the National Highway Traffic Safety Administration (NHTSA) in addition to notifying Multiquip Inc. at 1-800-421-1244.

If NHTSA receives similar complaints, it may open an investigation, and if it finds that a safety defect exists in a group of vehicles, it may order a recall and remedy campaign. However, NHTSA cannot become involved in individual problems between you, your dealer, or Multiquip Inc.

To contact NHTSA, you may either call the Vehicle Safety Hotline toll-free at 1-888-327-4236 (TTY: 1-800-424-9153), go to <http://www.safercar.gov>, or write to:

Administrator  
NHTSA  
1200 New Jersey Avenue, SE  
Washington, DC 20590

You can also obtain information about motor vehicle safety from <http://www.safercar.gov>.

# TABLE OF CONTENTS

## QP4TKT Series Trash Pump

Proposition 65 Warning .....	2
Reporting Safety Defects.....	3
Table Of Contents.....	4
Parts Ordering Procedures.....	5
Safety Information .....	6–10
Specifications .....	11
Dimensions.....	12
General Information.....	13
Pump Components.....	14–15
Engine Components.....	16–17
Inspection .....	18–19
Setup .....	20
Operation.....	21–22
Engine Maintenance.....	24–25
Pump Maintenance.....	26–28
Troubleshooting .....	29–31
Explanation Of Code In Remarks Column.....	32
Suggested Spare Parts .....	33

## Component Drawings

Decals (QP4TKT10) .....	34–35
Decals (QP4TKT16/QP4TKT28) .....	36–37
Trash Pump Assembly .....	38–41
Trailer Assembly (QP4TKT10).....	42–43
Trailer Assembly (QP4TKT16/QP4TKT28).....	44–45
Axle Assembly .....	46–47
Lifting Bail Assembly (QP4TKT16/28).....	48–49
Fuel Assembly (QP4TKT16).....	50–51
Fuel Assembly (QP4TKT28).....	52–53
Pump/Battery Mount Assembly (QP4TKT10)..	54–55
Battery Assembly (QP4TKT16/QP4TKT28) ....	56–57
Pump Mount Assembly (QP4TKT16/28) .....	58–59
Engine Service Parts.....	60–61
Terms And Conditions Of Sale — Parts .....	62

### NOTICE

Specifications and part numbers are subject to change without notice.

# SAFETY INFORMATION

Do not operate or service the equipment before reading the entire manual. Safety precautions should be followed at all times when operating this equipment. Failure to read and understand the safety messages and operating instructions could result in injury to yourself and others.



## SAFETY MESSAGES

The four safety messages shown below will inform you about potential hazards that could injure you or others. The safety messages specifically address the level of exposure to the operator and are preceded by one of four words: **DANGER**, **WARNING**, **CAUTION** or **NOTICE**.

## SAFETY SYMBOLS

<b>DANGER</b>
Indicates a hazardous situation which, if not avoided, <b>WILL</b> result in <b>DEATH</b> or <b>SERIOUS INJURY</b> .
<b>WARNING</b>
Indicates a hazardous situation which, if not avoided, <b>COULD</b> result in <b>DEATH</b> or <b>SERIOUS INJURY</b> .
<b>CAUTION</b>
Indicates a hazardous situation which, if not avoided, <b>COULD</b> result in <b>MINOR</b> or <b>MODERATE INJURY</b> .
<b>NOTICE</b>
Addresses practices not related to personal injury.

Potential hazards associated with the operation of this equipment will be referenced with hazard symbols which may appear throughout this manual in conjunction with safety messages.

Symbol	Safety Hazard
	Lethal exhaust gas hazards
	Explosive fuel hazards
	Burn hazards
	Respiratory hazards
	Accidental starting hazards
	Eye and hearing hazards

# SAFETY INFORMATION

## GENERAL SAFETY

### CAUTION

- **NEVER** operate this equipment without proper protective clothing, shatterproof glasses, respiratory protection, hearing protection, steel-toed boots and other protective devices required by the job or city and state regulations.



- **NEVER** operate this equipment when not feeling well due to fatigue, illness or when under medication.
- **NEVER** operate this equipment under the influence of drugs or alcohol.



### NOTICE

- This equipment should only be operated by trained and qualified personnel 18 years of age and older.
- Whenever necessary, replace nameplate, operation and safety decals when they become difficult to read.
- Manufacturer does not assume responsibility for any accident due to equipment modifications. Unauthorized equipment modification will void all warranties.
- **NEVER** use accessories or attachments that are not recommended by Multiquip for this equipment. Damage to the equipment and/or injury to user may result.
- **ALWAYS** know the location of the nearest fire extinguisher.
- **ALWAYS** know the location of the nearest first aid kit.
- **ALWAYS** know the location of the nearest phone or **keep a phone on the job site**. Also, know the phone numbers of the nearest ambulance, doctor and fire department. This information will be invaluable in the case of an emergency.

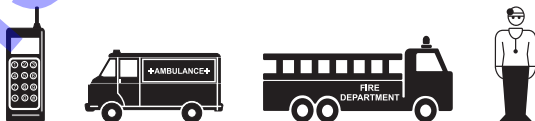

## PUMP SAFETY

### DANGER

- **NEVER** pump volatile, explosive, flammable or low flash point fluids. These fluids could ignite or explode.
- The engine fuel exhaust gases contain poisonous carbon monoxide. This gas is colorless and odorless, and can cause death if inhaled.
- The engine of this equipment requires an adequate free flow of cooling air. **NEVER** operate this equipment in any enclosed or narrow area where free flow of the air is restricted. If the air flow is restricted it will cause injury to people and property and serious damage to the equipment or engine.



- **NEVER** operate the equipment in an explosive atmosphere or near combustible materials. An explosion or fire could result causing severe **bodily harm or even death**.



### WARNING

- **NEVER** pump corrosive chemicals or water containing toxic substances. These fluids could create serious health and environmental hazards. Contact local authorities for assistance.
- **NEVER** open the priming plug when pump is hot. Hot water inside could be pressurized much like the radiator of an automobile. Allow pump to cool to the touch before loosening plug. The possibility exists of scalding, resulting in severe bodily harm.
- **NEVER** operate the pump with closed discharge hose. The liquid could reach boiling temperatures, build pressure, and cause the casing to rupture or explode.
- **NEVER** disconnect any emergency or safety devices. These devices are intended for operator safety. Disconnection of these devices can cause severe injury, bodily harm or even death. Disconnection of any of these devices will void all warranties.



# SAFETY INFORMATION

## CAUTION

- **NEVER** lubricate components or attempt service on a running machine.
- **NEVER** block or restrict flow from discharge hose. Remove kinks from discharge line before starting pump. Operation with a blocked discharge line can cause water inside pump to overheat.

## NOTICE

- **ALWAYS** fill the pump casing with water before starting the engine. Failure to maintain water inside the pump housing will cause severe damage to the pump and mechanical seal.
- In winter drain water from pump housing to prevent freezing.
- **NEVER** start the pump with the clean-out cover removed. The rotating impeller inside the pump can cut or sever objects caught in it. Before starting the pump, check that the clean-out cover is securely fastened.
- **ALWAYS** keep the machine in proper running condition.
- **ALWAYS** ensure pump is on level ground before use.
- Fix damage to machine and replace any broken parts immediately.
- **ALWAYS** store equipment properly when it is not being used. Equipment should be stored in a clean, dry location out of the reach of children and unauthorized personnel.

## ENGINE SAFETY

### WARNING

- **DO NOT** place hands or fingers inside engine compartment when engine is running.
- **NEVER** operate the engine with heat shields or guards removed.
- **DO NOT** remove the engine oil drain plug while the engine is hot. Hot oil will gush out of the oil tank and severely scald any persons in the general area of the pump.



## CAUTION

- **NEVER** touch the hot exhaust manifold, muffler or cylinder. Allow these parts to cool before servicing equipment.



## NOTICE

- **NEVER** run engine without an air filter or with a dirty air filter. Severe engine damage may occur. Service air filter frequently to prevent engine malfunction.
- **NEVER** tamper with the factory settings of the engine or engine governor. Damage to the engine or equipment can result if operating in speed ranges above the maximum allowable.



## FUEL SAFETY

### DANGER

- **DO NOT** start the engine near spilled fuel or combustible fluids. Fuel is extremely flammable and its vapors can cause an explosion if ignited.
- **ALWAYS** refuel in a well-ventilated area, away from sparks and open flames.
- **ALWAYS** use extreme caution when working with flammable liquids.
- **DO NOT** fill the fuel tank while the engine is running or hot.
- **DO NOT** overfill tank, since spilled fuel could ignite if it comes into contact with hot engine parts or sparks from the ignition system.
- Store fuel in appropriate containers, in well-ventilated areas and away from sparks and flames.
- **NEVER** use fuel as a cleaning agent.
- **DO NOT** smoke around or near the equipment. Fire or explosion could result from fuel vapors or if fuel is spilled on a hot engine.





# SAFETY INFORMATION

## BATTERY SAFETY (ELECTRIC START ONLY)

### DANGER

- **DO NOT** drop the battery. There is a possibility that the battery will explode.
- **DO NOT** expose the battery to open flames, sparks, cigarettes, etc. The battery contains combustible gases and liquids. If these gases and liquids come into contact with a flame or spark, an explosion could occur.



### WARNING

- **ALWAYS** wear safety glasses when handling the battery to avoid eye irritation. The battery contains acids that can cause injury to the eyes and skin.
- Use well-insulated gloves when picking up the battery.
- **ALWAYS** keep the battery charged. If the battery is not charged, combustible gas will build up.
- **DO NOT** charge battery if frozen. Battery can explode. When frozen, warm the battery to at least 61°F (16°C).
- **ALWAYS** recharge the battery in a well-ventilated environment to avoid the risk of a dangerous concentration of combustible gases.
- If the battery liquid (dilute sulfuric acid) comes into contact with **clothing or skin**, rinse skin or clothing immediately with plenty of water.
- If the battery liquid (dilute sulfuric acid) comes into contact with **eyes**, rinse eyes immediately with plenty of water and contact the nearest doctor or hospital to seek medical attention.



### CAUTION

- **ALWAYS** disconnect the **NEGATIVE** battery terminal before performing service on the equipment.
- **ALWAYS** keep battery cables in good working condition. Repair or replace all worn cables.

## TRANSPORTING SAFETY

### CAUTION

- **NEVER** allow any person or animal to stand underneath the equipment while lifting.

### NOTICE

- Before lifting, make sure that the equipment parts are not damaged and screws are not loose or missing.
- **ALWAYS** make sure forklift forks are inserted into pockets (if applicable) as far as possible when lifting the pump.
- **ALWAYS** shutdown engine before transporting.
- **NEVER** lift the equipment while the engine is running.
- Tighten fuel tank cap securely and close fuel cock to prevent fuel from spilling.
- Use one point suspension hook and lift straight upwards.
- **DO NOT** lift machine to unnecessary heights.
- **ALWAYS** tie down equipment during transport by securing the equipment with rope.
- Never allow any person or animal to stand underneath the equipment while lifting.

# SAFETY INFORMATION

## TOWING SAFETY

### ⚠ CAUTION

- Check with your local county or state safety towing regulations, in addition to meeting **Department of Transportation (DOT) Safety Towing Regulations**, before towing your equipment. 
- Refer to MQ Power trailer manual for additional safety information.
- In order to reduce the possibility of an accident while transporting the equipment on public roads, **ALWAYS** make sure the trailer that supports the equipment and the towing vehicle are mechanically sound and in good operating condition.
- **ALWAYS** shutdown engine before transporting
- Make sure the hitch and coupling of the towing vehicle are rated equal to, or greater than the trailer “gross vehicle weight rating.”
- **ALWAYS** inspect the hitch and coupling for wear. **NEVER** tow a trailer with defective hitches, couplings, chains, etc.
- Check the tire air pressure on both towing vehicle and trailer. **Trailer tires should be inflated to 50 psi cold.** Also check the tire tread wear on both vehicles.
- **ALWAYS** make sure the trailer is equipped with a **safety chain**.
- **ALWAYS** properly attach trailer’s safety chains to towing vehicle.
- **ALWAYS** make sure the vehicle and trailer directional, backup, brake and trailer lights are connected and working properly.
- DOT Requirements (if applicable) include the following:
  - Connect and test electric brake operation.
  - Secure portable power cables in cable tray with tie wraps.
- The maximum speed for highway towing is **55 MPH** unless posted otherwise. Recommended off-road towing is not to exceed **15 MPH** or less depending on type of terrain.

- Avoid sudden stops and starts. This can cause skidding, or jack-knifing. Smooth, gradual starts and stops will improve towing.
- Avoid sharp turns to prevent rolling.
- Trailer should be adjusted to a level position at all times when towing.
- Raise and lock trailer wheel stand in up position when towing.
- Place **chock blocks** underneath wheel to prevent **rolling** while parked.
- Place **support blocks** underneath the trailer’s bumper to prevent **tipping** while parked.
- Use the trailer’s swivel jack to adjust the trailer height to a level position while parked.

## ENVIRONMENTAL SAFETY

### NOTICE

- Dispose of hazardous waste properly. Examples of potentially hazardous waste are used motor oil, fuel and fuel filters. 
- **DO NOT** use food or plastic containers to dispose of hazardous waste.
- **DO NOT** pour waste, oil or fuel directly onto the ground, down a drain or into any water source.

# SPECIFICATIONS

Table 1. Pump Specifications			
Model	QP4TKT10	QP4TKT16	QP4TKT28
Type	Trash pump		
Suction x Discharge Size	4 x 4 in. (102 x 102 mm)		
Maximum Pumping Capacity	475 gal./min. (1,798 liters/min.)		
Maximum Solids Diameter	2 in. (51 mm)		
Maximum Lift	25 ft. (7.6 m)		
Maximum Head	85 ft. (26 m)		
Maximum Pressure	37.7 psi (260 kPa)		
Dry Net Weight (Pump)	286 lb. (130 kg)		
Dry Net Weight (Pump and Trailer)	571 lb. (259 kg)	686 lb. (311 kg)	756 lb. (343 kg)
Fuel Tank Capacity	5.2 quarts (4.9 liters)	16 gal. (61 liters)	28 gal. (106 liters)

Table 2. Engine Specifications	
Engine Model	Kubota OC95-EF02
Engine Type	Oil-cooled and forced air-cooling diesel engine
Displacement	25.3 in. <sup>3</sup> (0.416 liters)
Maximum Output	9.4 hp (7.0 kW) @ 3,600 rpm
Idle Speed	1,300 rpm
Fuel Type	Ultra-low sulfur diesel fuel
Engine Oil Type	API service CF-class (SEA #30, 20, 10W30)
Engine Oil Capacity	1.8 quarts (1.7 liters)
Starting Method	Electric start
Dry Net Weight	124 lb. (56.2 kg)

### Performance Curves Self-Priming Trash Pump

Pump Model : **QP4TK**    Engine : KUBOTA/ Diesel OC95    Power : 9.4 HP  
 Suction Line : 4 inch    Discharge Line : 4 inch

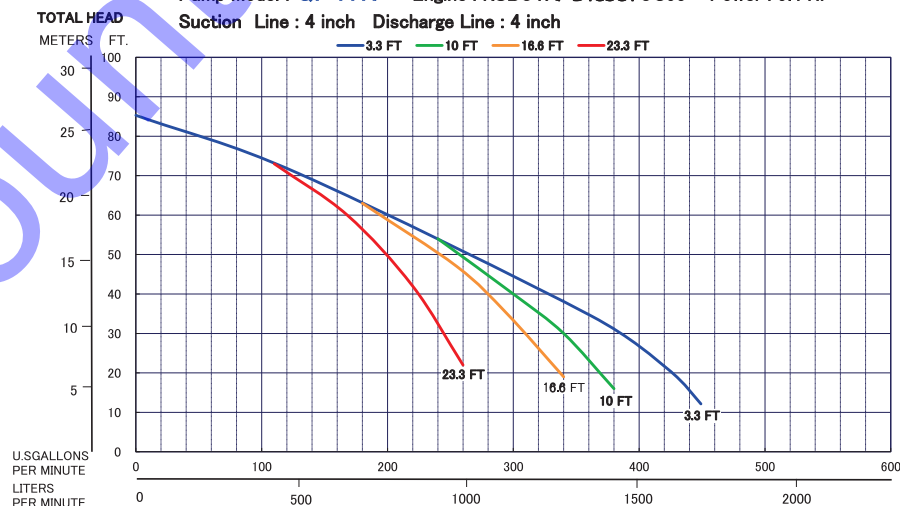

**Figure 1. Performance Curve**

# DIMENSIONS

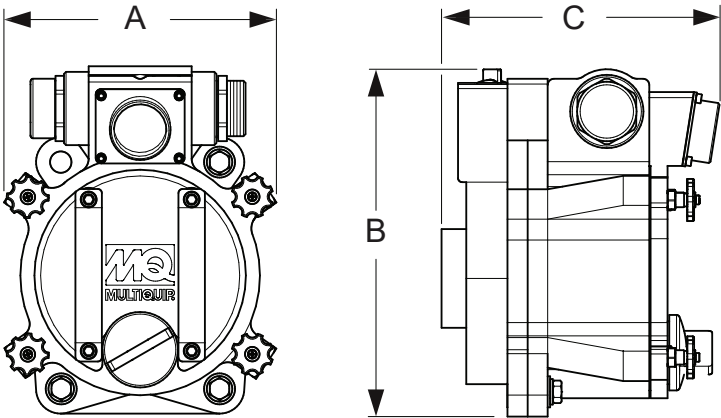

Table 3. Dimensions		
Reference Letter	QP4TKT10 in. (mm)	QP4TKT16/ QP4TKT28 in. (mm)
A	19 (483)	
B	24.2 (615)	
C	13.5 (343)	
D	52.4 (1,331)	56.5 (1,435)
E	28.4 (721)	
F	44.5 (1,130)	
G	49 (1,245)	
H	67 (1,702)	
I	23.5 (597)	
J	91.6 (2,327)	102 (2,591)
K	29 (737)	

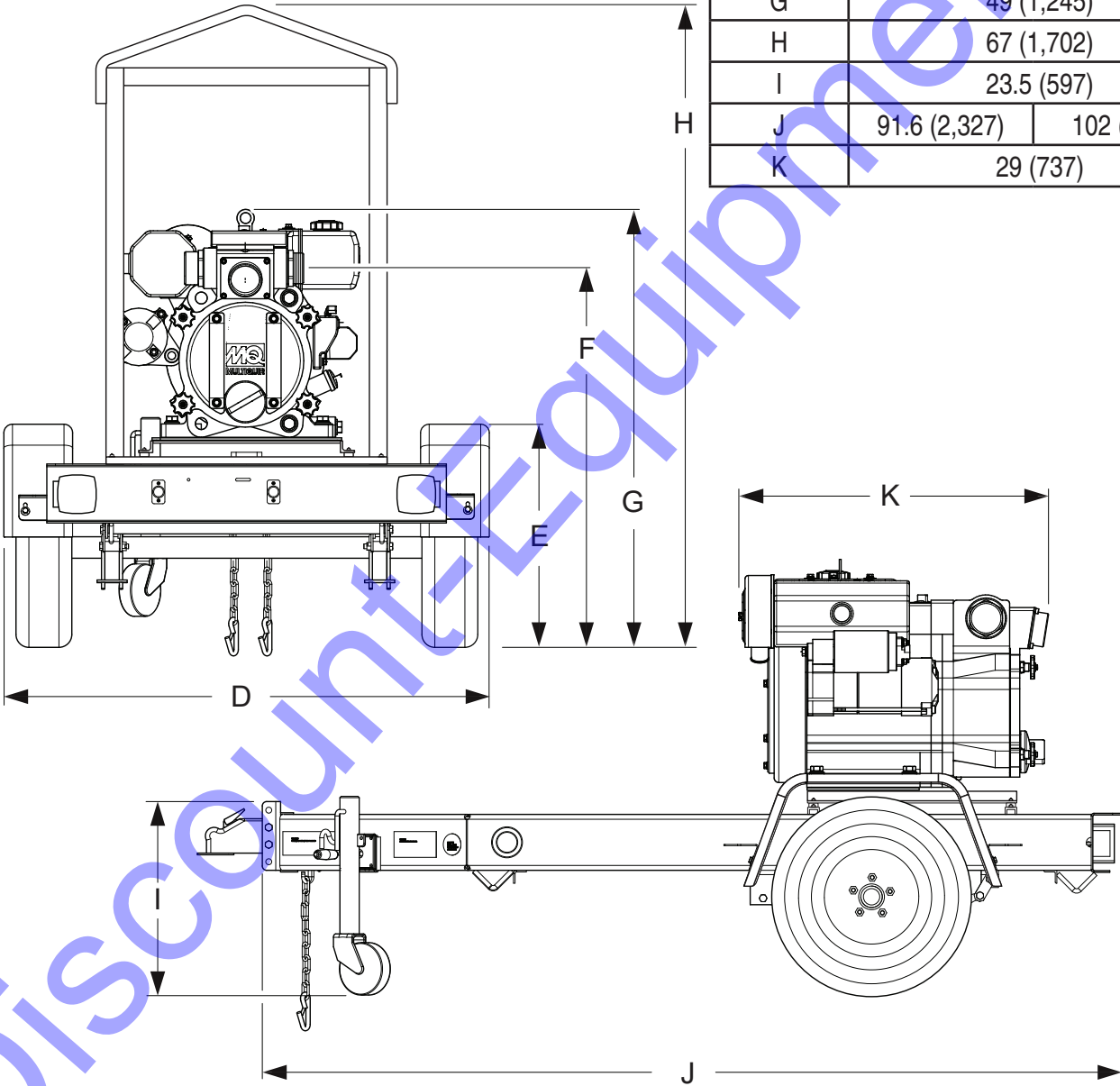

Figure 2. Dimensions

## GENERAL INFORMATION

The QP4TKT series trash pump is a self-priming pump powered by a 9.4-horsepower, oil- and air-cooled, Kubota diesel engine. The pump's suction and discharge ports are four inches in diameter, enabling a discharge rate of approximately 475 gpm (1,798 lpm).

### TRASH PUMPS

Trash pumps derive their name from their ability to handle a greater amount of solid debris than standard centrifugal pumps. Trash pumps are unlikely to clog, as they can handle water containing 25% solids by weight, and can accommodate solids up to one-half the size of the discharge opening. If the pump does become clogged, it can be disassembled quickly without the use of tools to allow for debris removal.

### PUMP PRIMING

The pump is **self-priming**, therefore **the pump casing must be filled with water before the pump is operated.**

The engine drives a rotating impeller that creates a partial vacuum (low pressure) within the pump. The reduced internal air pressure causes water to flow continuously into the pump through the suction line, and the centrifugal force of the impeller expels the water from the pump through the discharge ports.

**NEVER** attempt to operate the pump without filling the casing with water first.

### SUCTION LIFT

The QP4TKT series trash pump has a maximum suction lift of 25 feet (7.6 meters) at sea level. To obtain the optimum suction lift, **ALWAYS** place the pump as close to the water as possible and use the **shortest** possible suction line.

### ELEVATION

The elevation at which the pump is operated impacts its performance. Due to decreased atmospheric pressure at higher altitudes, the pump's priming ability is reduced as elevation increases.

Pumps generally lose one foot of priming ability for every 1,000 feet (305 meters) of elevation above sea level.

For example, in Flagstaff, Arizona, where the elevation is approximately 7,000 feet (2,134 meters) above sea level, a pump with a suction lift of 25 feet (7.6 meters) at sea level will have a suction lift of only 18 feet (5.5 meters).

Table 4 shows the difference in suction lift at various elevations.

**Table 4. Suction Lift at Various Elevations**

Altitude in Feet (Meters)	Suction Lift in Feet (Meters)			
Sea level	10 (3.0)	15 (4.6)	20 (6.1)	25 (7.6)
2,000 (609.6)	8.8 (2.7)	13.2 (4.0)	17.6 (5.4)	22 (6.7)
4,000 (1,219.2)	7.8 (2.4)	11.7 (3.6)	15.6 (4.8)	19.5 (5.9)
6,000 (1,828.8)	6.9 (2.1)	10.4 (3.2)	13.8 (4.2)	17.3 (5.3)
8,000 (2,438.4)	6.2 (1.9)	9.3 (2.8)	12.4 (3.8)	15.5 (4.7)
10,000 (3,048)	5.7 (1.7)	8.6 (2.6)	11.4 (3.5)	14.3 (4.4)

Table 5 shows the loss of performance as elevation increases.

**Table 5. Performance Loss at Various Elevations**

Altitude in Feet (Meters)	Discharge Flow	Discharge Head
Sea level	100%	100%
2,000 (609.6)	97%	95%
4,000 (1,219.2)	95%	91%
6,000 (1,828.8)	93%	87%
8,000 (2,438.4)	91%	83%
10,000 (3,048)	88%	78%

### TRAILERS

The QP4TKT10 is mounted on the basic TRLR10P trailer (1.45-gallon fuel tank).

The QP4TKT16 is mounted on the multipurpose TRLRMP16FP trailer (16-gallon fuel tank).

The QP4TKT28 is mounted on the multipurpose TRLRMPXFP trailer (28-gallon fuel tank).

### ACCESSORIES

Multiquip offers a complete line of fittings, hoses, and couplers for various pump applications. Refer to the parts list section of this manual for a complete list of accessories.

# PUMP COMPONENTS

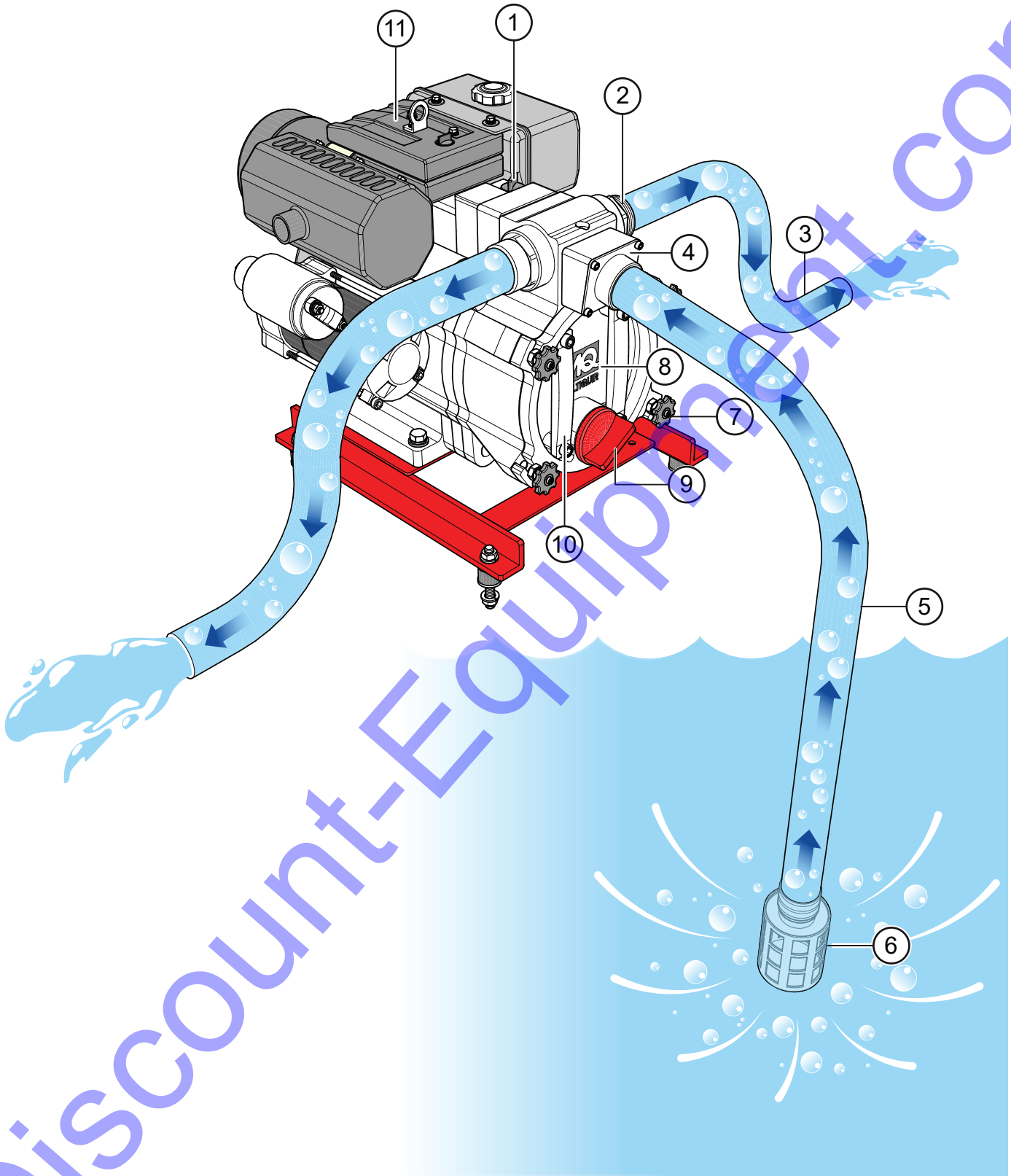

Figure 3. QP4TK Pump Components

## PUMP COMPONENTS

Figure 3 shows a typical QP4TKT series trash pump application. The main pump components are listed below.

1. **Fill Cap** — **The pump casing must be filled with water prior to operation!** Remove the fill cap to add water to the pump.

### WARNING

**NEVER** remove the fill cap while the pump is **hot**. Pressurized water inside can cause **serious injury**.

2. **Discharge Ports (2)** — 4-inch, male, NPT-threaded, left- and right-side discharge ports accommodate threaded hoses or pipes. Quick-connect hoses will fit onto the discharge ports with an optional coupler (P/N A400A). Contact the Multiquip Parts Department to order. PVC pipe or concrete pipe can also be connected to the discharge ports.
3. **Discharge Hoses (2)** — Discharge hoses are usually collapsible (thin-walled) hoses. However, if thin-walled discharge hoses are not available, rigid suction hoses may be substituted. **MAKE SURE** hoses lay flat and remain unkinked. Quick-connect hoses will fit onto the discharge ports with an optional coupler (P/N A400A). Contact the Multiquip Parts Department to order.
4. **Suction Port** — The 4-inch, male, NPT-threaded suction port accommodates a threaded or quick-connect hose. An optional coupler (P/N A400A) is necessary for quick-connect coupling. Contact the Multiquip Parts Department to order.
5. **Suction Hose** — Suction hoses are commonly reinforced with rigid PVC helix and are specifically designed to prevent collapse during operation. Use recommended suction hoses **only**. **MAKE SURE** the suction hose remains unkinked. A quick-connect hose will fit onto the suction port with an optional coupler (P/N A400A). Contact the Multiquip Parts Department to order.
6. **Strainer** — **ALWAYS** attach the strainer to the bottom end of the suction hose to prevent large objects and debris from entering the pump. Position the strainer so that it remains completely underwater.
7. **Locking Knobs (4)** — Loosen the locking knobs to open the clean-out cover and gain access to the casing cavity. Turn the knobs counterclockwise to loosen.
8. **Clean-Out Cover** — Opens to allow removal of debris from inside the pump. To open the cover, loosen the four locking knobs, grip the cover handles, and turn the cover counterclockwise. Once the cover is clear of the four knob fasteners, pull it outward to open.
9. **Drain Plug** — Remove the drain plug to drain water from the pump casing.
10. **Clean-Out Cover Handles (2)** — After loosening the four locking knobs, grip the handles and turn counterclockwise to open the clean-out cover.
11. **Diesel Engine** — A 9.4-horsepower, oil- and air-cooled, Kubota diesel engine. Refer to the **Engine Components** section of this manual for more information.

### NOTICE

Running the pump for sustained periods with the strainer above the water surface can damage the pump.

# ENGINE COMPONENTS

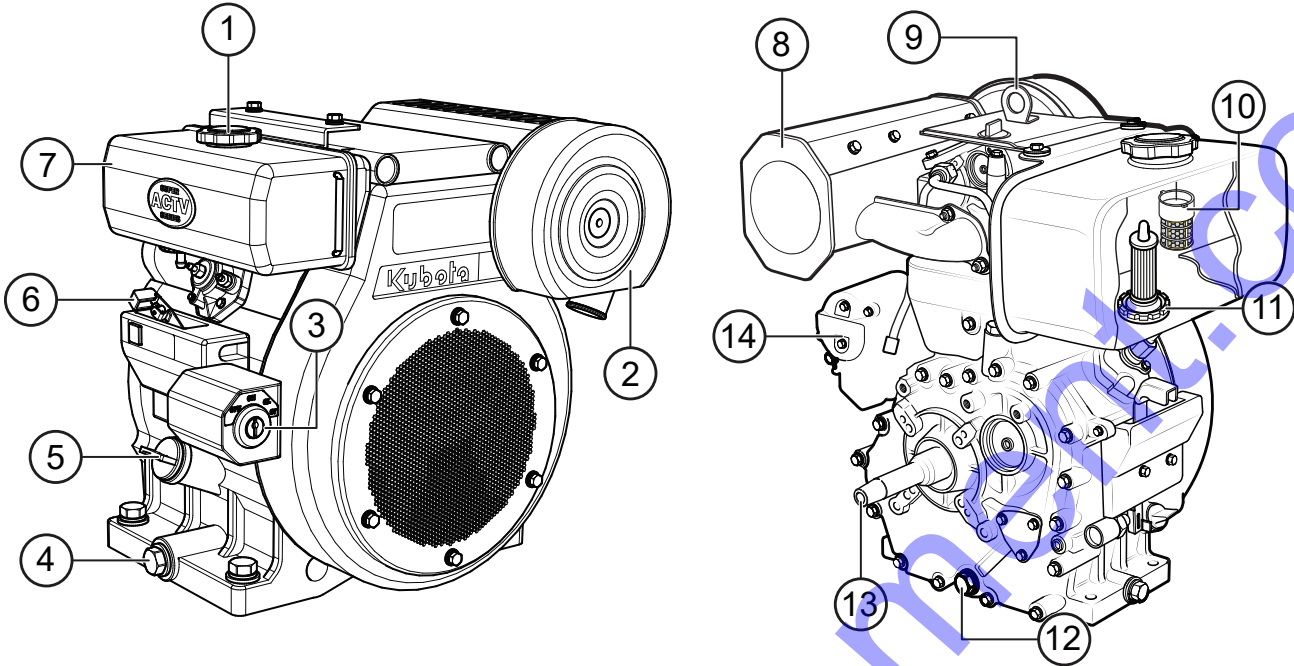

Figure 4. Kubota Engine Components

## INITIAL SERVICING

The engine (Figure 4) must be checked for proper lubrication and filled with fuel prior to operation. Refer to the manufacturer's engine manual for operation and maintenance information.

1. **Fuel Filler Cap** — Remove to add diesel fuel to the fuel tank. Make sure the cap is tightened securely. **DO NOT** overfill.

**! DANGER**

**NEVER** fill the fuel tank while the engine is running or **hot**. In the event of a fuel spill, **DO NOT** start the engine until all fuel residue has been wiped up and the area surrounding the engine is dry. Fuel is **extremely flammable** and can ignite if it comes into contact with hot engine parts or sparks from the ignition system.



2. **Air Cleaner** — Prevents dirt and other debris from entering the fuel system. Remove the wing nut on top of the air cleaner cover to gain access to the filter element.
3. **Ignition Switch** — Insert the ignition key here and turn clockwise to start the engine.

4. **Oil Drain Bolts (2)** — There are two oil drain bolts, one on each side of the engine. Remove either bolt to drain oil from the engine crankcase.
5. **Oil Filler Cap/Dipstick** — Remove to determine if engine oil is low. Add oil through this port as recommended in Table 6.
6. **Speed Control Lever** — Controls engine speed (RPM).
7. **Fuel Tank** — Model QP4TKT10 utilizes the engine's 1.45-gallon stock fuel tank (Figure 4). Model QP4TKT16 utilizes a 16-gallon polyethylene fuel tank secured within the trailer bed. Model QP4TKT28 utilizes a 28-gallon polyethylene fuel tank secured within the trailer bed. The use of low or ultra-low sulfur diesel fuels is recommended for optimal engine performance.
8. **Muffler** — Reduces noise and emissions. **NEVER** touch the muffler while it is **hot**.

**! WARNING**

Engine components can generate **extreme heat**. To prevent burns, **NEVER** touch these areas while the engine is running, or immediately after operation. **NEVER** operate the engine with the muffler removed.





9. **Lifting Bail** — Attach a suitable strap or chain here when lifting of the engine is necessary.
10. **Fuel Strainer** — Model QP4TKT10 utilizes the engine's stock fuel tank. The fuel strainer is located within the fuel fill port of the tank (Figure 4). Models QP4TKT16 and QP4TKT28 utilize a polyethylene fuel tank secured within the trailer bed and **do not** provide an individual mechanical fuel strainer bowl.
11. **Fuel Filter** — Model QP4TKT10 utilizes the engine's stock fuel tank. The fuel filter is located within the tank. Models QP4TKT16 and QP4TKT28 utilize a polyethylene fuel tank secured within the trailer bed. The fuel filter is part of the fuel tank assembly. Refer to the parts list illustration for its location.
12. **Oil Filter** — Remove this bolt to gain access to the engine oil filter. Service the oil filter as recommended in the **Maintenance** section of this manual.
13. **Crankshaft** — Connects to the pump engine coupling.
14. **Electric Starter** — Starts the engine when the ignition key is inserted and turned to the **START** position.

# INSPECTION

## PRE-INSPECTION

1. Clean the unit, removing dirt and dust—particularly the engine cooling air inlet.
2. Inspect the air cleaner for dirt and dust. If the air cleaner is dirty, replace it with a new one. See the **Maintenance** section of this manual for more information.
3. Check fastening nuts and bolts for tightness.
4. The QP4TKT series trash pump utilizes a common 12V “C” post type battery for electric start. Check the security of the battery within the battery box and that the connectors are equally secure on their posts.

## ENGINE OIL

1. Place the unit on secure, level ground with the engine turned **OFF**.
2. Remove the engine oil dipstick from the engine oil filler hole (Figure 5) and wipe it clean.

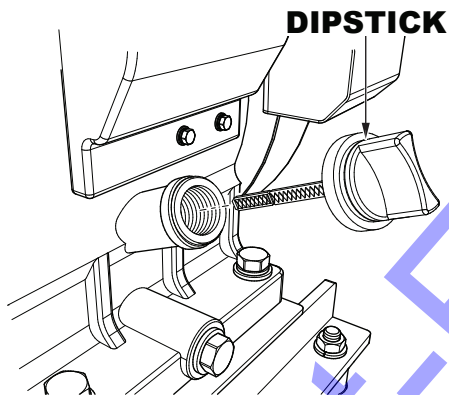

Figure 5. Engine Oil Dipstick Removal

3. Reinsert the dipstick into the filler hole, then remove it again without screwing it in.

4. Check the oil level on the dipstick (Figure 6). If the oil level is low, fill to the edge of the oil filler hole with the recommended oil type (Table 6). Maximum oil capacity is 1.8 quarts (1.7 liters).

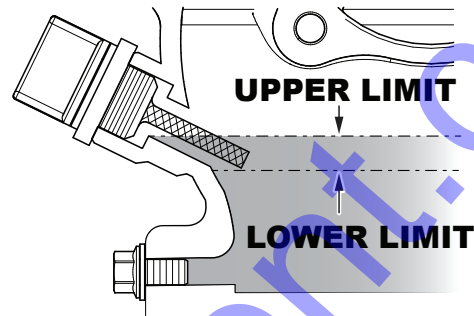

Figure 6. Engine Oil Inspection

Table 6. Recommended Oil Types

Season	Temperature	Oil Type
Summer	25°C or higher	SAE 10W-30
Spring/Fall	25°C–10°C	SAE 10W-30/20
Winter	0°C or lower	SAE 10W-10

### NOTICE

The engine oil level must be checked **daily**. There is no low oil shutoff feature and operating the pump with low oil levels will cause **severe damage to the engine**.

## FUEL

### DANGER



Motor fuels are **highly flammable** and can be dangerous if mishandled. **NEVER** smoke while refueling. **NEVER** attempt to refuel while the engine is **hot** or **running**.

1. Identify and remove the fuel cap. On pump model QP4TKT10, the fuel cap is located on top of the engine fuel tank (Figure 7). On pump models QP4TKT16 and QP4TKT28, the fuel cap is located near the front of the trailer, on top of the fuel pickup tube (Figure 8).

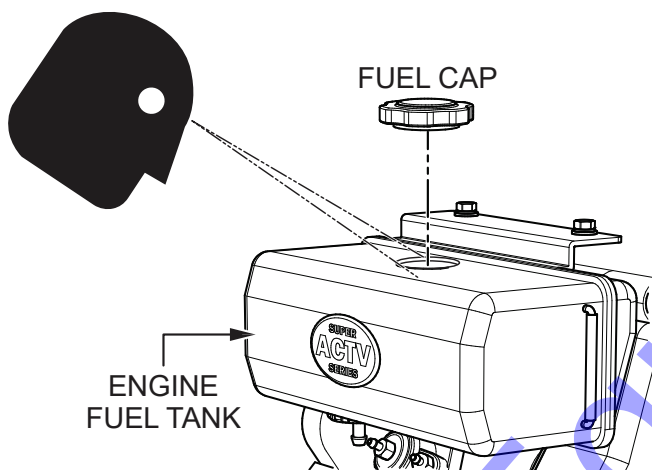

Figure 7. Fuel Inspection (QP4TKT10)

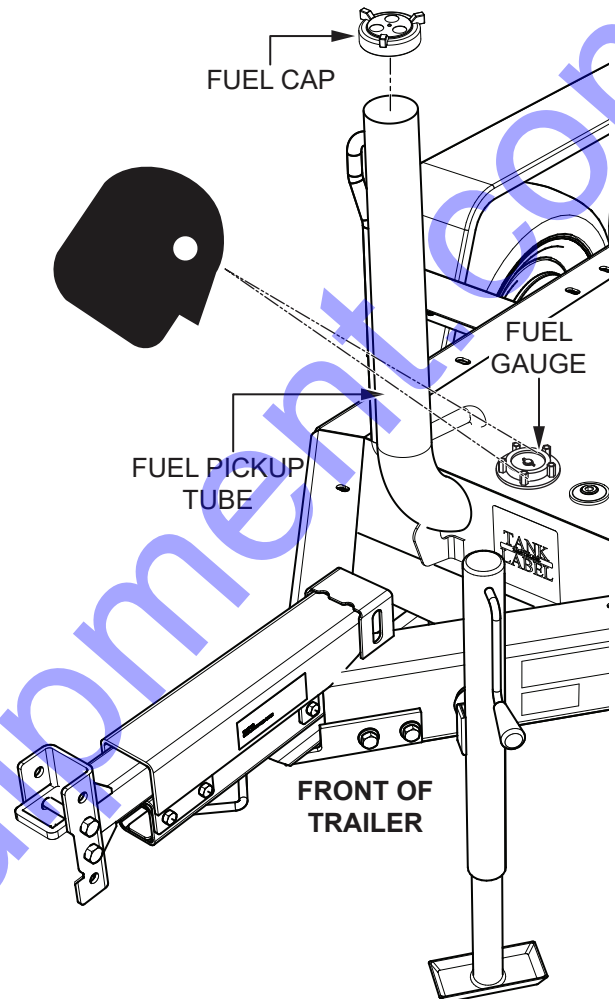

Figure 8. Fuel Inspection (QP4TKT16/QP4TKT28)

2. Check the fuel level. On pump model QP4TKT10, visually inspect the fuel level inside the engine fuel tank (Figure 7). On pump model QP4TKT16 or QP4TKT28, read the fuel gauge located near the base of the fuel pickup tube (Figure 8).
3. If the fuel level is low, fill the tank with low or ultra-low sulfur diesel fuel **only**. Use a fuel strainer for filtration while refueling, and replace the fuel cap when finished. **DO NOT** top off fuel. Wipe up any spilled fuel **immediately**.

## SETUP

Pump performance (flow, head, velocity and pressure) is determined by multiple factors, including operating altitude, suction lift, the length and diameter of the hoses, friction loss, the specific gravity and temperature of the fluid being pumped, and total discharge head. Set up the pump as follows to achieve optimal pump performance.

1. Place the pump on a solid, level operating surface as close as possible to the water source. The most critical factor for successful pump operation is the total suction lift, which should not exceed 25 feet (7.6 meters) at sea level. See Figure 9.
2. Initialize self-priming of the pump by removing the fill cap and filling the pump casing with water.

### NOTICE

**THE PUMP CASING MUST BE FILLED WITH WATER PRIOR TO OPERATION.** Self-priming of the pump will not take place unless the pump casing is filled with water.

### NOTICE

This pump uses a water-cooled mechanical seal to prevent water from seeping into the engine. The passage of water through the pump casing lubricates the seal and prevents it from overheating. **NEVER** operate the pump without water in the casing, as this can damage the mechanical seal.

3. Check for water leakage between the pump and the engine, which may indicate that the seal inside the pump is worn or damaged. Continued operation of the pump in this condition is **not recommended**, and can cause **severe water damage to the engine**.

4. Connect suitable hoses to the suction and discharge ports. **MAKE SURE** the hoses are tightly secured to their respective ports, have O-rings in place, and are free of any kinks, cracks, gouges, or holes. Using **two** hose clamps to secure the suction hose to the suction port is **recommended**.

### NOTICE

Suction and discharge hoses are available from Multiquip. Contact your local MQ dealer for more information.

5. **MAKE SURE** the strainer is clean and securely attached to the water end of the suction hose. Position the strainer so it will remain **completely underwater**, but is not buried in any underlying sand or silt.

### NOTICE

Sustained pump operation with the strainer above the water surface can damage the pump.

6. **MAKE SURE** the discharge hoses lay as straight as possible and remain unrestricted. Remove any twists or sharp bends which may impede the flow of water.

### NOTICE

Discharge hoses are usually collapsible (thin-walled) hoses. However, if thin-walled discharge hoses are not available, rigid suction hoses may be substituted. PVC pipe or concrete pipe can also be connected to the discharge ports.

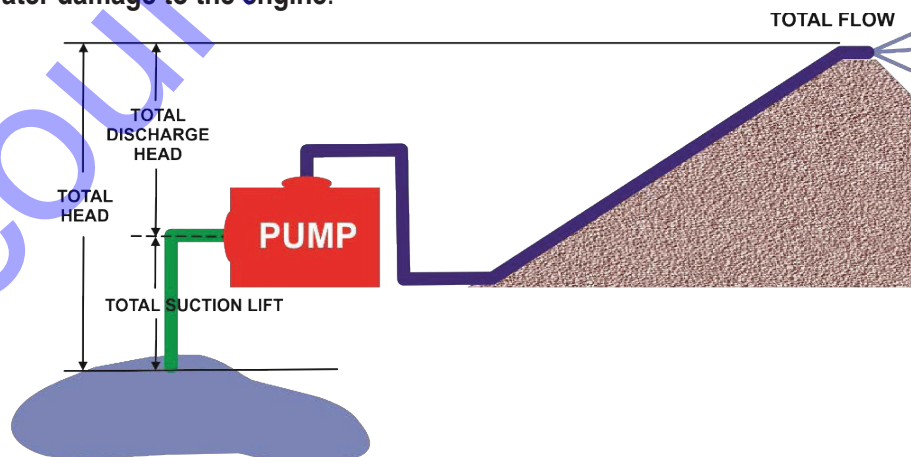

Figure 9. Pump Setup

## **DANGER**



**NEVER** operate the pump in a confined area or enclosed structure that does not provide an ample free flow of air.

## **WARNING**

**NEVER** pump flammable fluids, corrosive chemicals, or fluids containing toxic substances. These fluids can create potentially dangerous health and environmental hazards. Contact local authorities for assistance.

## **CAUTION**



**DO NOT** attempt to operate the pump until the **Safety Information**, **General Information**, and **Inspection** sections of this manual have been read and thoroughly understood.

## **CAUTION**



**ALWAYS** wear approved eye and hearing protection while operating the pump.

## **NOTICE**

**NEVER** attempt to start the engine unless the pump has first been primed with water. **Severe damage will occur** to the pump's mechanical seal if the pump has not been primed.

## STARTING THE ENGINE

1. Move the engine speed control lever to the **START** position (Figure 10).

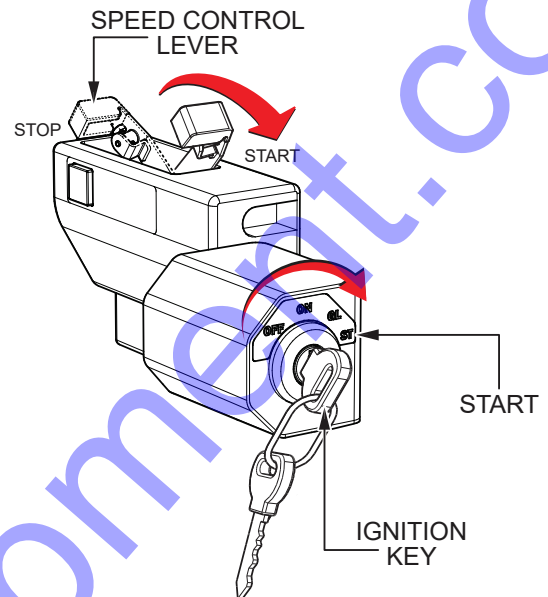

**Figure 10. Starting the Engine**

2. Turn the ignition key to the **START** position (Figure 10). Release the key when the engine starts.
3. Move the engine speed control lever to the **IDLE** position (Figure 11). Run the engine at idle for several minutes and check for any abnormal conditions such as extreme vibration, loose components, or fluid leaks.

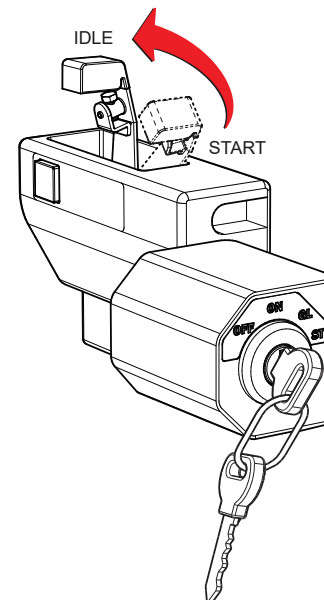

**Figure 11. Engine Speed Control Lever (IDLE)**

4. Move the engine speed control lever back to the **START** position to begin pumping. The priming process will take a few moments before water begins to flow.

### NOTICE

**ALWAYS** run the engine at **full speed** while pumping.

## STOPPING THE ENGINE

### Normal Shutdown

#### CAUTION

When stopping the engine, reduce the load **slowly**. Avoid stopping the engine suddenly, which can cause abnormal temperature rise.

1. Move the engine speed control lever to the **IDLE** position and run the engine for three minutes with no load.
2. Turn the ignition key to the **OFF** position.
3. Move the engine speed control lever to the **STOP** position.

### Emergency Shutdown

To stop the engine **immediately**, quickly turn the ignition key to the **OFF** position.

## ENGINE MAINTENANCE

Perform engine maintenance procedures according to Table 7 below.

Table 7. Engine Maintenance Schedule							
Description (3)	Operation	Before Each Use	First Month or 10 Hrs.	Every 3 Months or 25 Hrs.	Every 6 Months or 50 Hrs.	Every Year or 100 Hrs.	Every 2 Years or 200 Hrs.
Engine Oil	Check	X					
	Change		X				
Air Cleaner	Check	X					
	Change			X (1)			
All Nuts and Bolts	Re-tighten if necessary	X					
Cooling Fins	Check				X		
Spark Arrester	Clean					X	
Fuel Tank	Clean					X	
Fuel Filter	Check					X	
Idle Speed	Check/Adjust					X (2)	
Valve Clearance	Check/Adjust						X (2)
Fuel Lines	Check	Every 2 years (replace if necessary) (2)					

(1) Service more frequently when used in **dusty** areas.

(2) These items should be serviced by your service dealer, unless you have the proper tools and are mechanically proficient. Refer to the Kubota engine manual for service procedures.

(3) For commercial use, log hours of operation to determine proper maintenance intervals.

# ENGINE MAINTENANCE

## DAILY

### **⚠ DANGER**



To prevent a possible fire or explosion, **NEVER** use fuel as a cleaning solvent.

- Thoroughly clean dirt and debris from the pump and engine.
- Check the engine oil level and add oil as recommended in Table 6 if needed.
- Inspect the air cleaner element and replace it if necessary.
- Check all fasteners and retighten as necessary.

## Engine Oil

### NOTICE

The engine oil level must be checked **daily**. There is no low oil shutoff feature and operating the pump with low oil levels will cause **severe damage to the engine**.

### NOTICE

**ALWAYS** drain the engine oil while the oil is **warm**.

1. Remove the oil filler cap/dipstick (Figure 12) and set it aside.

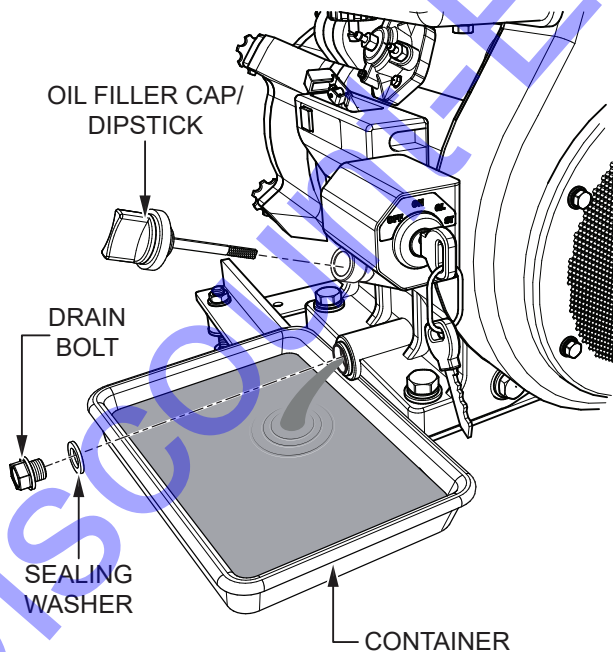

Figure 12. Engine Oil Replacement

2. Remove the oil drain bolt and sealing washer and allow the oil to drain into a suitable container (Figure 12).
3. Reinstall the drain bolt and sealing washer and tighten them securely.
4. Add engine oil as recommended in Table 6. Engine oil capacity is 1.8 quarts (1.7 liters). **DO NOT** overfill.
5. Reinstall the oil filler cap/dipstick.

## Air Cleaner

### NOTICE

Operating the engine without an air filter, or with a damaged or worn air filter in need of replacement, will allow dirt to enter the engine, causing rapid engine wear.

1. Remove and set aside the wing nut and washer securing the air cleaner cover to the air cleaner (Figure 13).

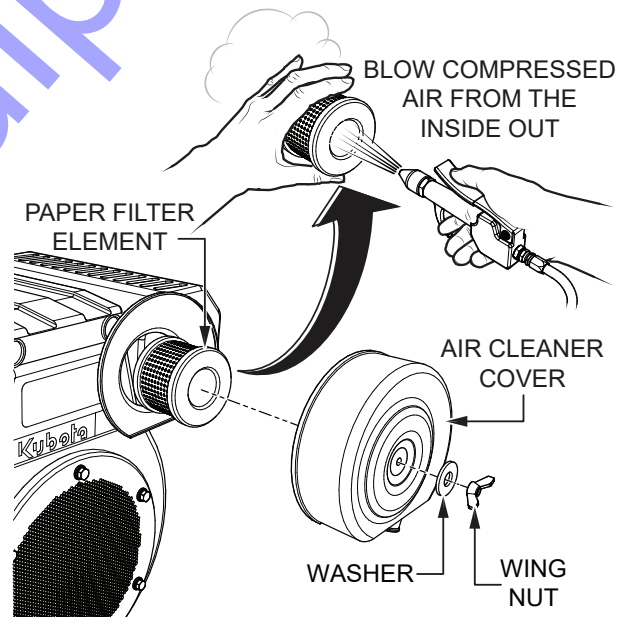

Figure 13. Air Cleaner Maintenance

2. To remove dirt, tap the paper filter element several times on a hard surface, or blow compressed air [not exceeding 30 psi (207 kPa, 2.1 kgf/cm<sup>2</sup>)] through the element from the inside out. **NEVER** brush off dirt. Brushing will force dirt into the fibers. Replace the paper filter element if it is excessively dirty.
3. Reinstall the air cleaner cover and secure it with the wing nut.



# PUMP MAINTENANCE

PLACE VACUUM TESTER  
OVER PUMP SUCTION PORT

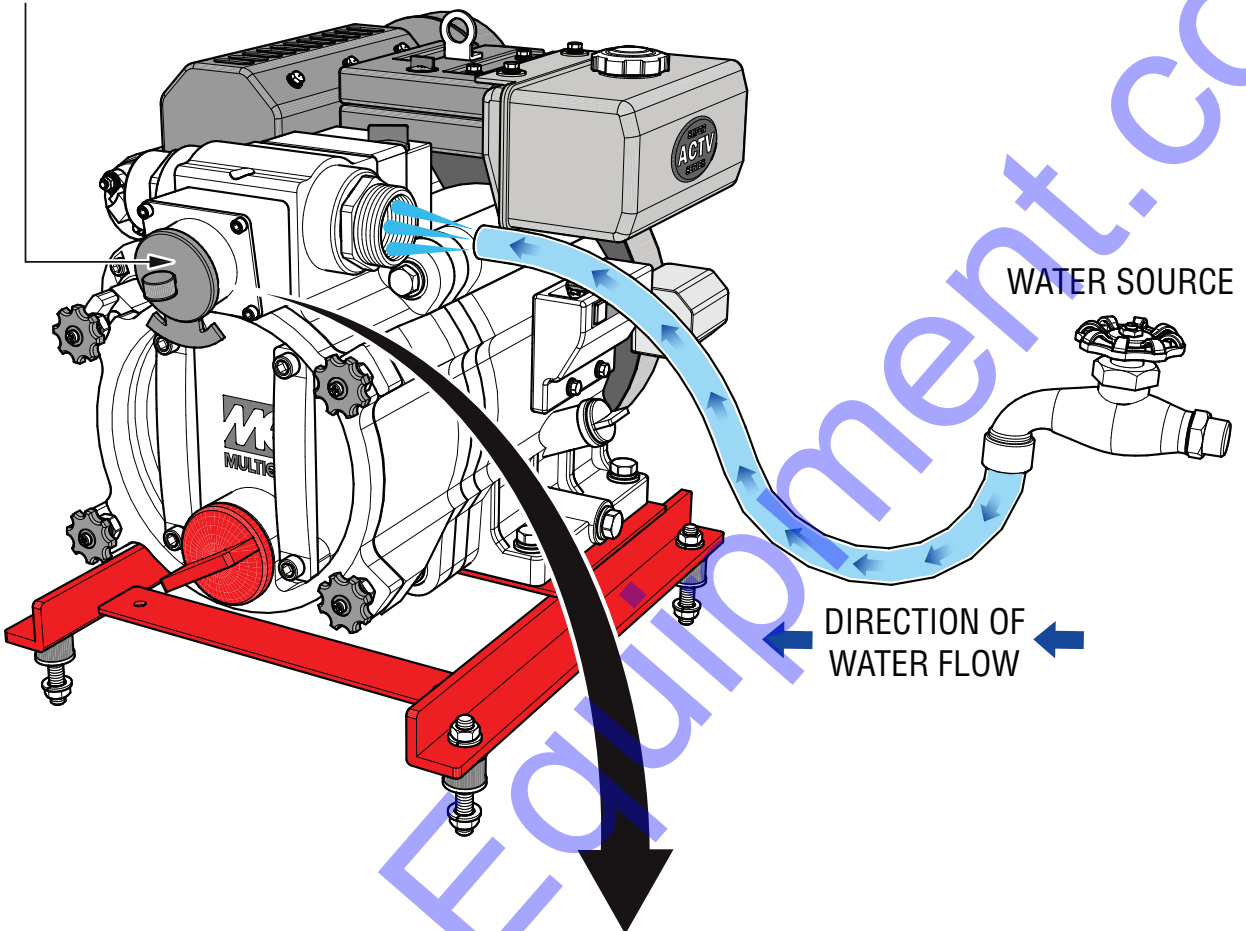

ACCEPTABLE READING IS  
BETWEEN -25 AND -20 inHg

25 inHg TRANSLATES INTO 25 FEET  
OF LIFT AT SEA LEVEL

PUMP VACUUM TESTER

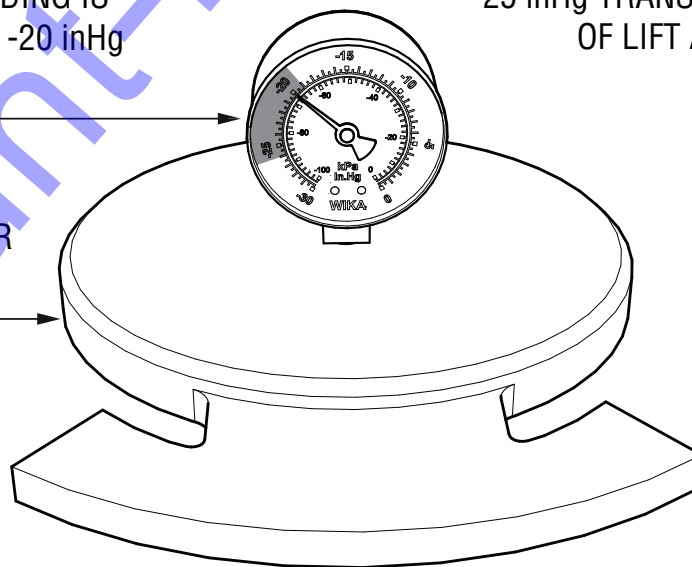

Figure 14. Pump Vacuum Test

# PUMP MAINTENANCE

## PUMP VACUUM TEST

Perform the following procedure to test the pump vacuum. Refer to Figure 14.

1. Remove the pump fill cap and fill the pump casing with water.

### WARNING

**NEVER** remove the fill cap while the pump is **hot**. Water inside may be **under pressure**.

2. Start the engine as described in the **Operation** section, and wait for the pump to begin pumping.
3. Place a water hose inside one of the discharge ports, and turn on the water. The flow of water into the discharge port will prevent the pump from running dry.
4. Place the pump vacuum tester (P/N 7000030) over the suction port with the vacuum gauge facing **upward**. It may be necessary to apply a small amount of water around the rubber seal of the vacuum tester to create a proper seal.
5. Make sure there are no air leaks between the vacuum tester and the suction port. If air leaks are present, reset the vacuum tester.
6. Run the pump for a few minutes while monitoring the vacuum gauge. A gauge reading of 20–25 inHg (inches of mercury) indicates that the pump is working properly. A gauge reading below 20 inHg indicates that the pump is not working properly.

### NOTICE

25 inHg (inches of mercury) translates into 25 feet of suction lift at sea level.

7. To test the flapper valve, shut down the engine. The vacuum tester should remain attached to the suction port by vacuum, indicating that the flapper valve is seating properly and holding water in the suction hose when the engine is stopped. This prevents backflow and allows for faster priming when the engine is restarted.

## IMPELLER CLEARANCE ADJUSTMENT

Every six months, inspect the impeller, shaft seal, and shaft sleeve for wear, and check the clearance between the impeller and the volute. The impeller should be as close to the volute as possible without touching it.

1. Adjust the clearance between the impeller and the volute by adding or removing shims behind the impeller.

### NOTICE

Removing too many shims will create excessive clearance between the impeller and the volute, resulting in reduced pump performance.

As the impeller wears down over time, additional shims may be required to maintain minimal clearance between the impeller and the volute.

2. Turn the ignition key to the **START** position, then quickly turn it back to the **OFF** position, which will cause the impeller to rotate just a bit. Repeat this a few times while checking the clearance between the impeller and the volute.

If it becomes necessary to replace the impeller or the volute, make sure the clearance between the impeller and the volute is adjusted correctly.

## PUMP CLEANING

After pumping water with a large quantity of dirt and debris, perform the following procedure to clean out the pump:

1. Remove the drain plug from the pump housing to drain any water remaining in the pump.
2. Loosen the four locking knobs by turning them counterclockwise. Grip the clean-out cover handles, twist counterclockwise, and pull outward to open the clean-out cover.
3. Clean inside the pump casing and remove all dirt and debris. Inspect the impeller and volute for wear. Replace any damaged or worn parts.

### CAUTION

The impeller can develop sharp edges. **BE CAREFUL** when cleaning around the impeller to prevent injury.

### LONG-TERM STORAGE

Prepare the pump for long-term storage (more than 30 days) as follows.

- Run the engine for about three minutes, then stop the engine.
- While the engine is off but still warm, drain the engine oil. Fill the engine crankcase with fresh oil.
- Drain the fuel tank completely.
- Wipe off any oil or dirt that has accumulated on the engine.
- Remove the drain plug from the pump and completely drain any water left in the pump housing.
- Open the pump cover and clean the interior of the pump casing. Coat the interior of the pump casing with a light film of oil to reduce corrosion. A spray can of oil works well for this application.
- To protect the water-cooled seals, pour a half-pint of lubricating oil through the discharge opening on the pump and crank the engine several times. This will keep the mechanical seal lubricated and prevent excessive corrosion.
- Cover the suction and discharge ports with duct tape to prevent any foreign matter from entering the pump.
- Disconnect the battery cables.
- Cover the pump and engine with a plastic sheet and store them out of direct sunlight, in a location that is free of moisture and dust.

# TROUBLESHOOTING

Troubleshooting (Trash Pump)		
Symptom	Possible Problem	Solution
Pump does not prime.	Not enough water in the housing?	Add water.
	Engine speed too low?	Increase engine RPM to full speed.
	Strainer plugged?	Clean strainer.
	Suction hose damaged?	Replace or repair hose and clamps.
	Air leak at suction port?	Check that fittings are tight and properly sealed.
	Pump located too high above water line?	Move pump closer to water.
	Debris collecting in pump housing?	Clean pump housing.
	Too much distance between impeller and volute?	Replace impeller or adjust clearance by adding shims. 0.01 – 0.02 inch (0.25 – 0.51 mm)
	Water leaking out of sight glass?	Check condition of mechanical seal.
Pump takes in water, little or no discharge.	Engine speed too low?	Increase engine RPM to full speed.
	Suction strainer partially plugged?	Clean strainer.
	Worn impeller or volute?	Adjust clearance or replace impeller/volute.
Suction hose leaks at inlet.	Fittings/clamps are not sealed properly?	Tighten, replace or add clamp. (Keep extra seals on pump).
	Hose diameter too large?	Use correct diameter hose.
Discharge does not stay on coupling.	Pressure too high?	Check pressure, add additional clamp.
	Hose kinked or end blocked?	Check hose.
Engine is locked or slow to start.	Impeller jammed or blocked?	Open pump cover and clean dirt and debris from inside housing.
	Impeller and wear plate binding?	Inspect for clearance 0.01 – 0.02 inch (0.25 – 0.51 mm). Add or remove shims.
	Defective engine?	See engine owner's manual.
	Impeller binding to rear adaptor plate?	Adjust clearance by adding or removing shims 0.025 – 0.040 inch (0.64 – 1.02 mm)

# TROUBLESHOOTING

Troubleshooting (Engine)		
Symptom	Possible Problem	Solution
Engine will not start or start is delayed, although engine can be turned over.	No Fuel reaching injection pump?	Add fuel. Check entire fuel system.
	Defective fuel pump?	Replace fuel pump.
	Fuel filter clogged?	Replace fuel filter and clean tank.
	Faulty fuel supply line?	Replace or repair fuel line.
	Compression too low?	Check piston, cylinder and valves. Adjust or repair per engine repair manual.
	Fuel pump not working correctly?	Repair or replace fuel pump.
	Oil pressure too low?	Check engine oil pressure.
	Low starting temperature limit exceeded?	Comply with cold starting instructions and proper oil viscosity.
	Defective battery?	Charge or replace battery.
	Air or water mixed in fuel system?	Check carefully for loosened fuel line coupling, loose cap nut, etc.
At low temperatures engine will not start.	Engine oil too thick?	Refill engine crankcase with correct type of oil for winter environment.
	Defective battery?	Replace battery.
Engine fires but stops soon as starter is switched off.	Fuel filter blocked?	Replace fuel filter.
	Fuel supply blocked?	Check the entire fuel system.
	Defective fuel pump?	Replace fuel pump.
Engine stops by itself during normal operation.	Fuel tank empty?	Add fuel.
	Fuel filter blocked?	Replace fuel filter.
	Defective fuel pump?	Replace fuel pump.
	Mechanical oil pressure shutdown sensor stops the engine due to low oil?	Add oil. Replace low oil shutdown sensor if necessary.
Low engine power, output and speed.	Fuel tank empty?	Replace fuel filter.
	Fuel filter clogged?	Replace fuel filter.
	Fuel tank venting is inadequate?	Ensure that tank is adequately vented.
	Leaks at pipe unions?	Check threaded pipe unions tape and tighten unions as required.
	Speed control lever does not remain in selected position?	See engine manual for corrective action.
	Engine oil level too full?	Correct engine oil level.
	Injection pump wear?	Use No. 2-D diesel fuel only. Check the fuel injection pump element and delivery valve assembly and replace as necessary.

## TROUBLESHOOTING

Troubleshooting (Engine) - continued		
Symptom	Possible Problem	Solution
Low engine power output and low speed, black exhaust smoke.	Air filter blocked?	Clean or replace air filter.
	Incorrect valve clearances?	Adjust valves per engine specification.
	Malfunction at injector?	See engine manual.
Engine overheats.	Too much oil in engine crankcase?	Drain off engine oil down to uppermark on dipstick.
	Entire cooling air system contaminated/ blocked?	Clean cooling air system and cooling fin areas.
	Fan belt broken or elongated?	Change belt or adjust belt tension.
	Coolant insufficient?	Replenish coolant.
	Radiator net or radiator fin clogged with dust?	Clean net or fin carefully.
	Fan, radiator, or radiator cap defective?	Replace defective part.
	Thermostat defective?	Check thermostat and replace if necessary.
	Head gasket defective or water leakage?	Replace parts.

# EXPLANATION OF CODE IN REMARKS COLUMN

The following section explains the different symbols and remarks used in the Parts section of this manual. Use the help numbers found on the back page of the manual if there are any questions.

## NOTICE

The contents and part numbers listed in the parts section are subject to change **without notice**. Multiquip does not guarantee the availability of the parts listed.

## SAMPLE PARTS LIST

NO.	PART NO.	PART NAME	QTY.	REMARKS
1	12345	BOLT .....	1	INCLUDES ITEMS W/%
2%		WASHER, 1/4 IN. ....		NOT SOLD SEPARATELY
2%	12347	WASHER, 3/8 IN. ...	1	MQ-45T ONLY
3	12348	HOSE .....	A/R	MAKE LOCALLY
4	12349	BEARING .....	1	S/N 2345B AND ABOVE

## NO. Column

**Unique Symbols** — All items with same unique symbol (@, #, +, %, or >) in the number column belong to the same assembly or kit, which is indicated by a note in the “Remarks” column.

**Duplicate Item Numbers** — Duplicate numbers indicate multiple part numbers, which are in effect for the same general item, such as different size saw blade guards in use or a part that has been updated on newer versions of the same machine.

## NOTICE

When ordering a part that has more than one item number listed, check the remarks column for help in determining the proper part to order.

## PART NO. Column

**Numbers Used** — Part numbers can be indicated by a number, a blank entry, or TBD.

TBD (To Be Determined) is generally used to show a part that has not been assigned a formal part number at the time of publication.

◆ A blank entry generally indicates that the item is not sold separately or is not sold by Multiquip. Other entries will be clarified in the “Remarks” Column.

## QTY. Column

**Numbers Used** — Item quantity can be indicated by a number, a blank entry, or A/R.

A/R (As Required) is generally used for hoses or other parts that are sold in bulk and cut to length.

A blank entry generally indicates that the item is not sold separately. Other entries will be clarified in the “Remarks” Column.

## REMARKS Column

Some of the most common notes found in the “Remarks” Column are listed below. Other additional notes needed to describe the item can also be shown.

**Assembly/Kit** — All items on the parts list with the same unique symbol will be included when this item is purchased.

Indicated by:

“INCLUDES ITEMS W/(unique symbol)”

**Serial Number Break** — Used to list an effective serial number range where a particular part is used.

Indicated by:

“S/N XXXXX AND BELOW”

“S/N XXXX AND ABOVE”

“S/N XXXX TO S/N XXX”

**Specific Model Number Use** — Indicates that the part is used only with the specific model number or model number variant listed. It can also be used to show a part is NOT used on a specific model or model number variant.

Indicated by:

“XXXXX ONLY”

“NOT USED ON XXXX”

**“Make/Obtain Locally”** — Indicates that the part can be purchased at any hardware shop or made out of available items. Examples include battery cables, shims, and certain washers and nuts.

**“Not Sold Separately”** — Indicates that an item cannot be purchased as a separate item and is either part of an assembly/kit that can be purchased, or is not available for sale through Multiquip.

## SUGGESTED SPARE PARTS

### QP4TK TRASH PUMP

1 to 3 units

Qty.	P/N	Description
2	.....0803442930	.....MECHANICAL SEAL
2	.....0811885443	.....MECH. SEAL SLEEVE
2	.....0482200240	.....O-RING, SEAL SLEEVE
1	.....1471040031	ASSY .IMPELLER
2	.....0631211159	.....FLOODING CAP
1	.....KIT4TK	.....KIT, MECHANICAL SEAL

#### NOTICE

Part numbers on this Suggested Spare Parts list may supersede/replace the part numbers shown in the following parts lists.

### OC95 KUBOTA DIESEL ENGINE

1 to 3 units

Qty.	P/N	Description
1	.....1142041030	.....CAP, FUEL TANK
1	.....1146043012	.....FUEL FILTER
1	.....1390141350	.....FUEL STRAINER
5	.....1491132110	.....OIL FILTER
3	.....1146011180	.....AIR FILTER



# DECALS (QP4TKT10)

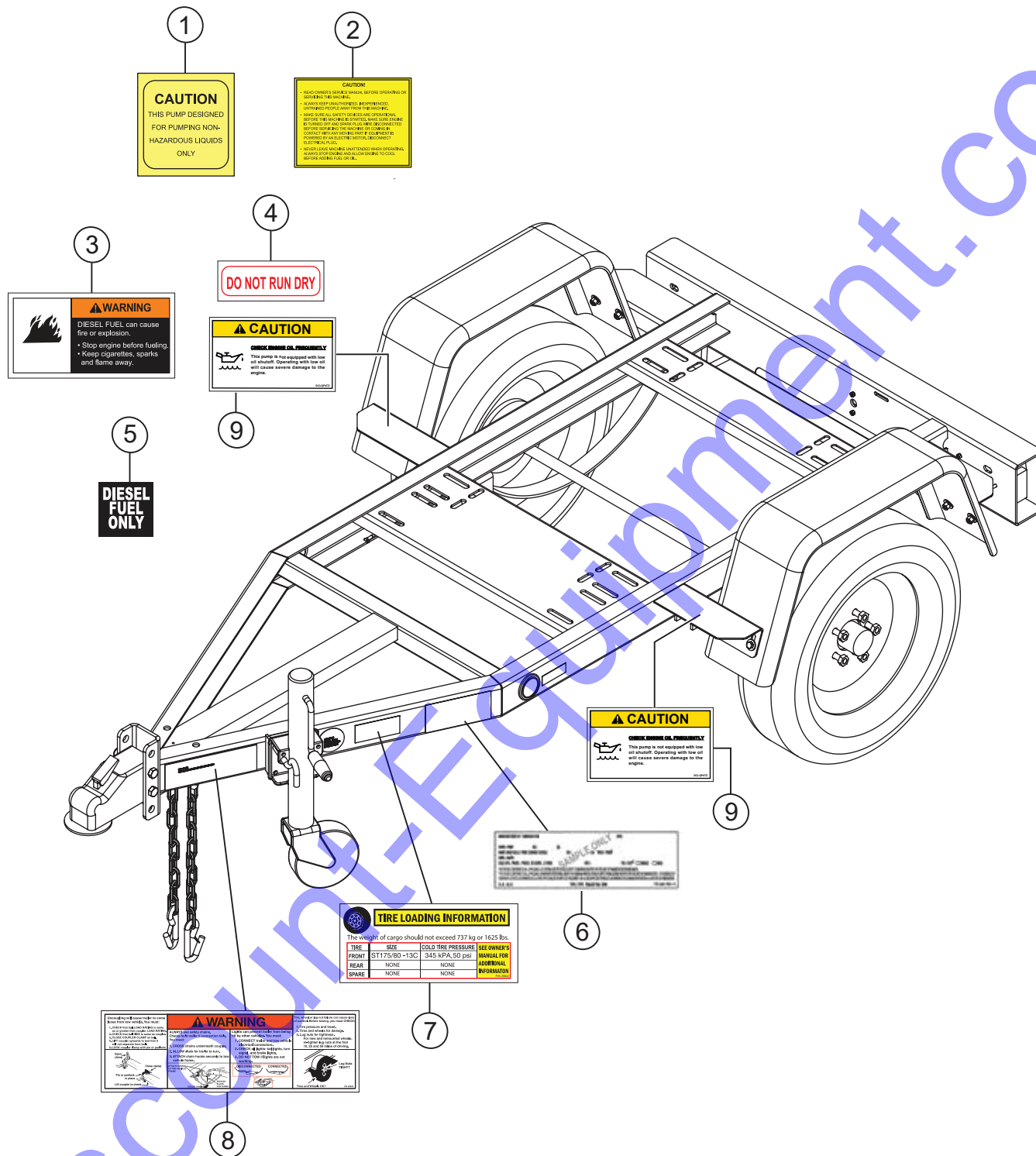

## DECALS (QP4TKT10)

<u>NO.</u>	<u>PART NO.</u>	<u>PART NAME</u>	<u>QTY.</u>	<u>REMARKS</u>
1	DCS02	DECAL, PUMP SAFETY	1	
2	920203290	DECAL, CAUTION .....	1	NPA329
3	B9504500004	DECAL, WARNING .....	1	
4	27188	DECAL, DO NOT RUN .....	1	
5	1630680004	DECAL, DIESEL FUEL ONLY	1	
6	9315	DECAL, TRAILER 10, VIN	1	
7	29842	DECAL, TIRE LOADING	1	
8	49002	DECAL, TRLR HITCH/WHEEL WARNING	1	
9	DCLQP4TZ	DECAL, FREQUENTLY CHECK OIL LEVEL	2	

# DECALS (QP4TKT16/QP4TKT28)

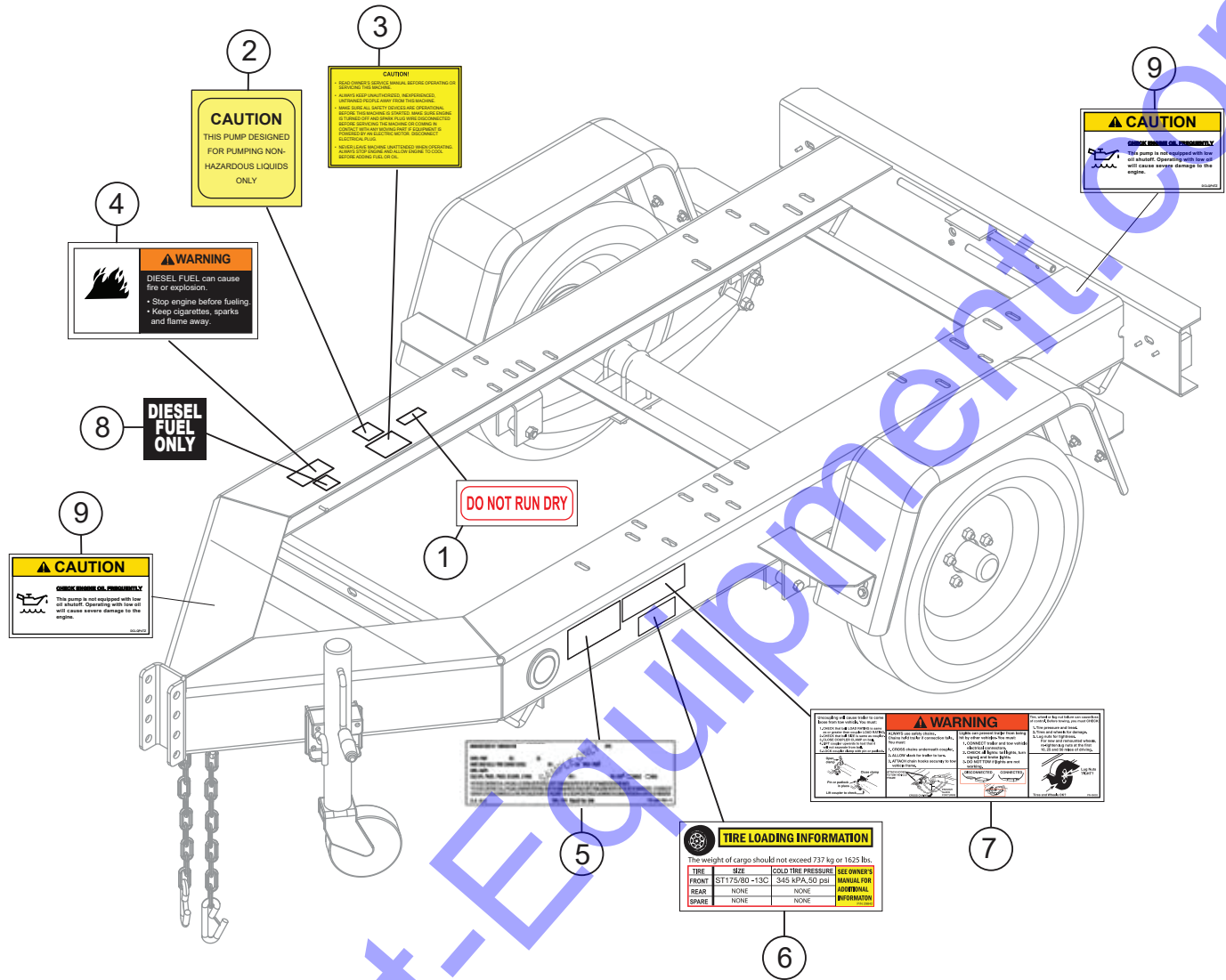

## DECALS (QP4TKT16/QP4TKT28)

<u>NO.</u>	<u>PART NO.</u>	<u>PART NAME</u>	<u>QTY.</u>	<u>REMARKS</u>
1	27188	DECAL, DO NOT RUN	1	
2	DCS02	DECAL, PUMP SAFETY	1	
3	920203290	DECAL, CAUTION .....	1.....	NPA329
4	B9504500004	DECAL, WARNING	1	
5	29680	DECAL, MULTIPLE TRAILER, VIN	1	
6	29842	DECAL, TIRE LOADING	1	
7	49002	DECAL, TRLR HITCH/WHEEL WARNING	1	
8	1630680004	DECAL, DIESEL FUEL ONLY	1	
9	DCLQP4TZ	DECAL, FREQUENTLY CHECK OIL LEVEL	2	

# TRASH PUMP ASSY.

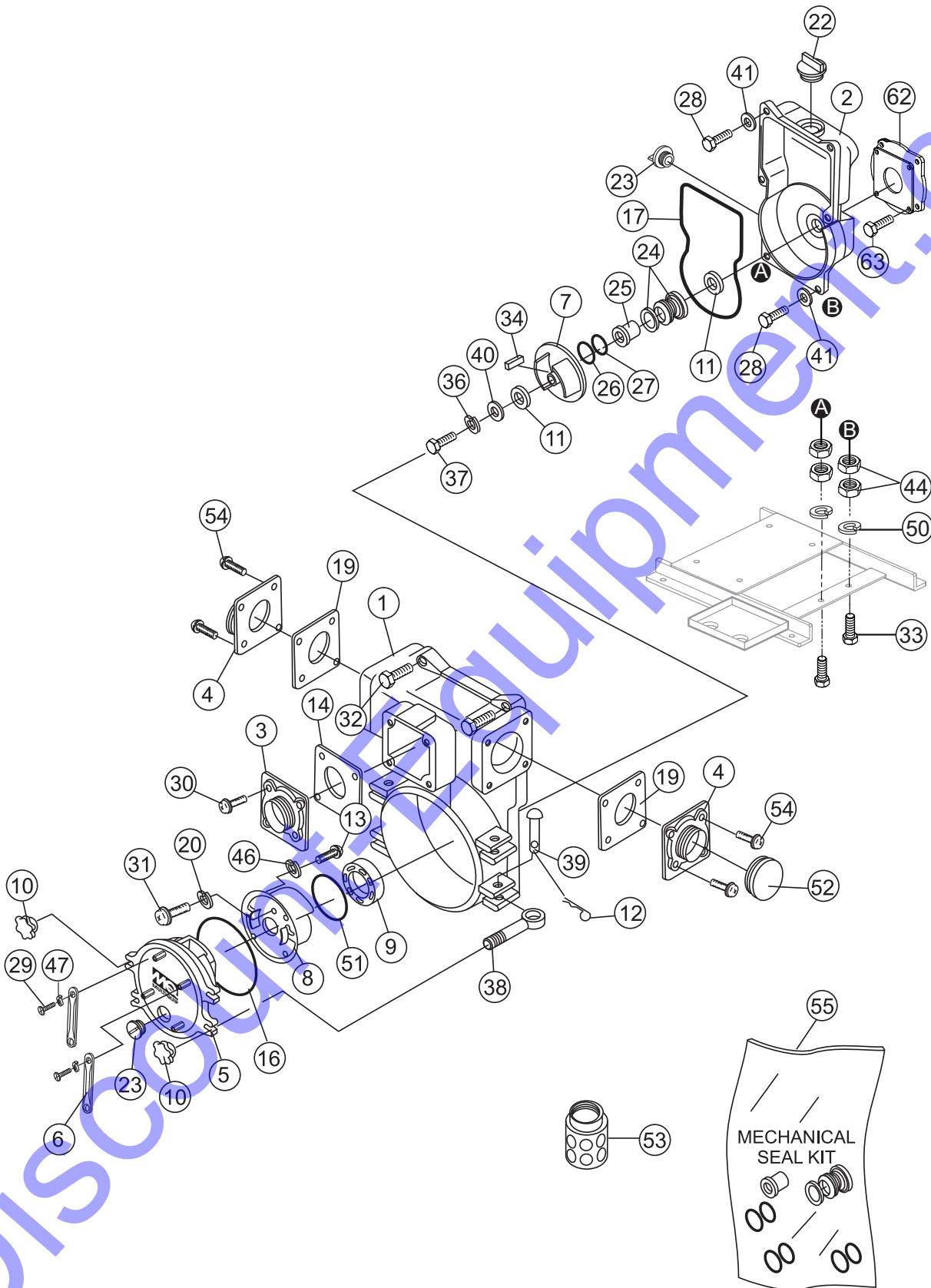

## TRASH PUMP ASSY.

<u>NO.</u>	<u>PART NO.</u>	<u>PART NAME</u>	<u>QTY.</u>	<u>REMARKS</u>
1	14660600100002	CASING	1	
2	14660600210002	CASING COVER	1	
3	14660000900002	SUCTION COVER, NPT 4"	1	
4	14660000900002	DELIVERY COVER, NPT 4"	2	
5	14660601700002	DRAIN COVER	1	
6	12471002500002	DRAIN COVER SET HANDLE	2	
7	1471040031ASSY	IMPELLER ASSEMBLY .....	1	REPLACES P/N 1471040031
8	1466000130	VOLUTE CASING	1	
9	1466040700	WEAR PLATE	1	
10	14660002200002	DRAIN SET HANDLE	4	
11#	0482200240	O-RING (MECHANICAL SEAL SLEEVE)	2	
12	0641400430	SPLIT PIN	4	
13	0131190820	CAP SCREW, M8 X 20 (VOLUTE CASING)	3	
14	1401350350	CHECK VALVE	1	
16	0483602750	O-RING (DRAIN COVER)	1	
17	1466330460	O-RING (CASING)	1	
19	1401330360	DELIVERY COVER PACKING	2	
20	0451290080	WASHER, LOCK M8 (WEAR PLATE)	3	
22	0631211159	FLOODING CAP, PF1 1/2"	1	
23	0631211159	DRAIN CAP, PF1 1/2"	2	
24#	0803442930	MECHANICAL SEAL	1	
25#	0811885433	MECHANICAL SEAL SLEEVE	1	
26#	0852834525	ADJUST LINER, F45 X F25.4 T0.3	1	
27#	0852854525	ADJUST LINER, F45 X F25.4 T0.5	1	
28	0131290676	CAP SCREW, 3/8"-16UNC X 76 (CASING COVER SET BOLT)	4	
29	0141050825	SCREW, M8 X 25 (DRAIN COVER SET HANDLE)	4	
30	0131151225	CAP SCREW, M12 X 25 (SUCTION COVER)	4	
31	0131190820	CAP SCREW, M8 X 20 (WEAR PLATE)	3	
32	0131151230	CAP SCREW, M12 X 30 (CASING)	6	
33	0105051040	BOLT, M10 X 40 (PUMP)	2	
34	0520040440	KEY	1	
36	0458220100	WASHER, SEAL (IMPELLER)	1	
37	0191190750	BOLT, (IMPELLER)	1	
38	1466200270	HINGE BOLT, M10 X 65	4	
39	1466220280	HINGE PIN	4	

# TRASH PUMP ASSY. (CONT'D.)

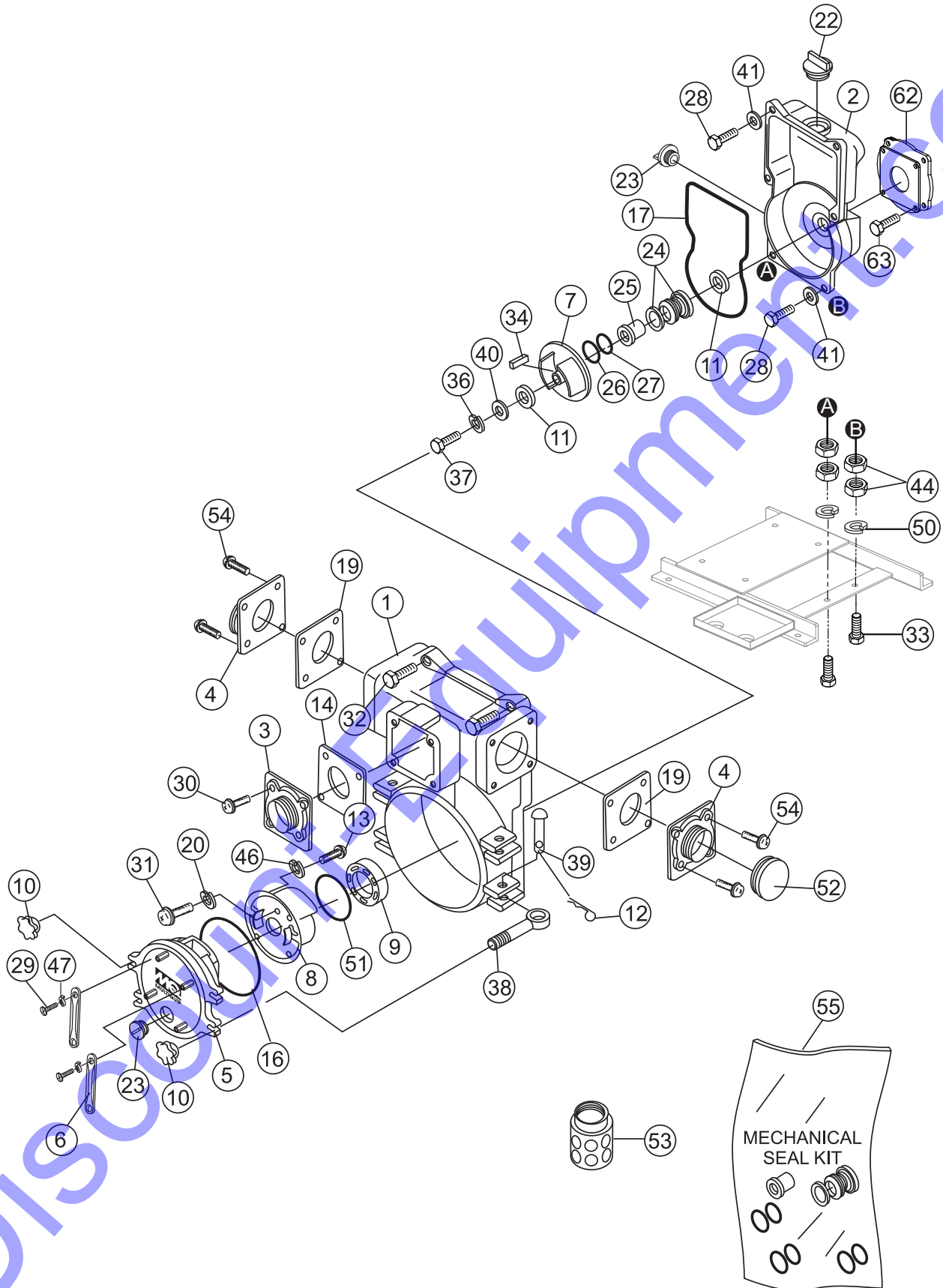

## TRASH PUMP ASSY. (CONT'D.)

<u>NO.</u>	<u>PART NO.</u>	<u>PART NAME</u>	<u>QTY.</u>	<u>REMARKS</u>
40	1466251241	IMPELLER WASHER, 42 X 9.8 X T6.0.....	1	REPLACES P/N 43342012400011
41	0458220071	SEAL WASHER, 3/8" (CASING COVER)	4	
43	0205450100	NUT, M10 (CUSHION RUBBER)	8	
44	0205450100	NUT, M10 (PUMP)	4	
46	0451290080	WASHER, SPRING M8 (VOLUTE CASING)	3	
47	0451250080	WASHER, SPRING M8 (DRAIN COVER SET HANDLE)	4	
50	0451250100	WASHER, SPRING M10 (PUMP)	2	
51	0481572500	O-RING (VOLUTE CASING)	1	
52	1466108050	CAP	1	
53	0742214100	STRAINER	1	
54	0131151220	CAP SCREW, M12 X 20 (DELIVERY COVER)	8	
55	KIT4TK	KIT, MECHANICAL SEAL, SLEEVE, O-RINGS...	1	INCLUDES ITEMS W/#
62	24820006000014	CASING COVER SET PLATE	1	
63	0141090820	SCREW, (CASING COVER SET PLATE)	4	



# TRAILER ASSY. (QP4TKT10)

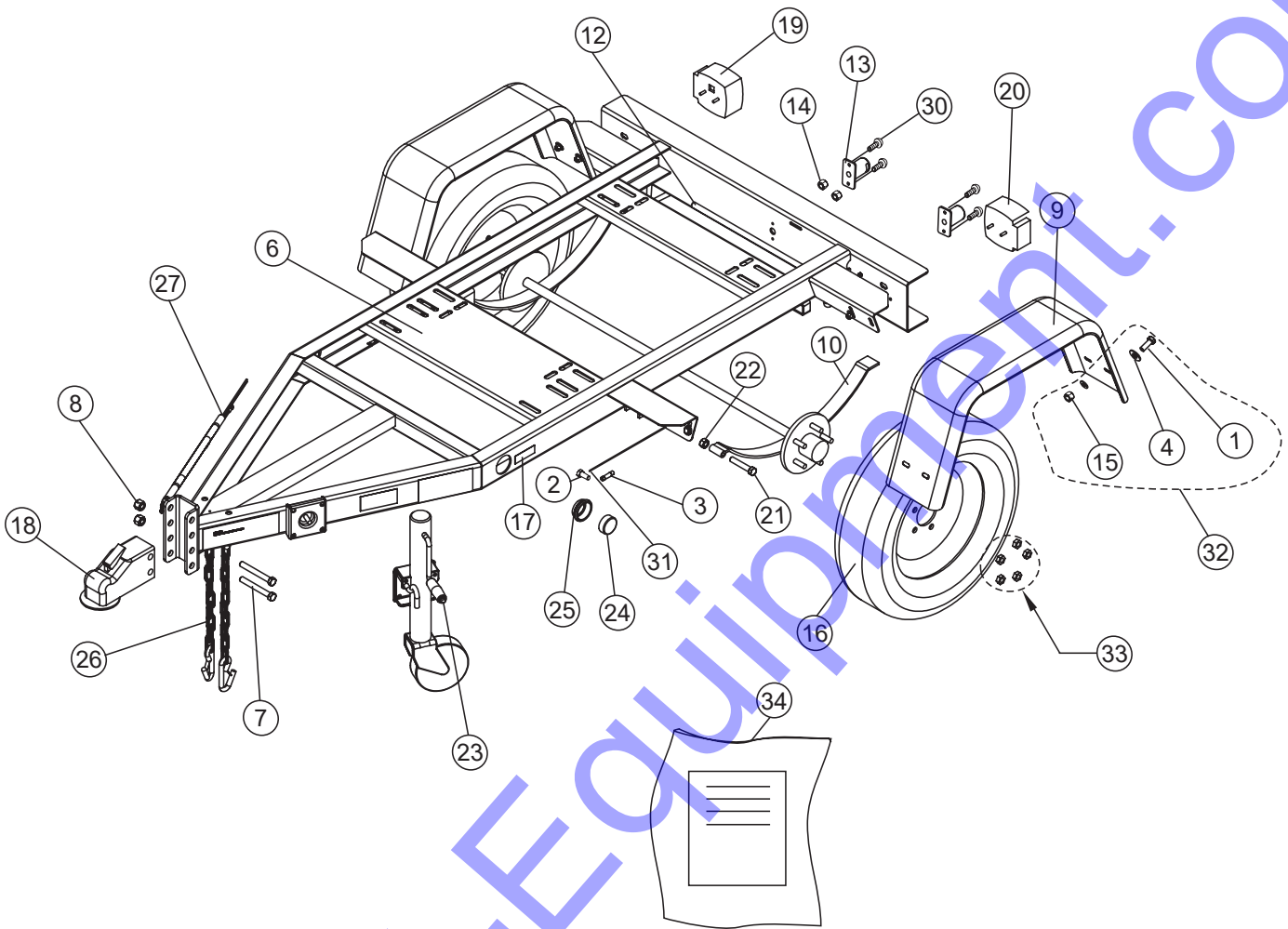

## TRAILER ASSY. (QP4TKT10)

<u>NO.</u>	<u>PART NO.</u>	<u>PART NAME</u>	<u>QTY.</u>	<u>REMARKS</u>
1#	0205	SCREW, HHC 3/8-16 X 1.0	8	
2	1273	SCREW, HHST 8-32 X 3/8	2	
3	2540	CONNECTOR, BUTT SPLICE, 16-14	2	
4#	4001	WASHER, FLAT USS 3/8 PLD	16	
6	9500	FRAME, TRLR10W W/A	1	
7	9502	SCREW, HHC 5/8-11 X 4-1/2 GRD 8	2	
8	9503	NUT, NYLOC 5/8-11	2	
9	9505	FENDER, 8 X 30 X 13	2	
10	9506	AXLE SPRG. ASSY., 43" HF, 27" SPRG. CTR	1	
11	9509	SCREW, TEK 12 X 3/4 SELF TAP	1	
12	9512	INSULATOR, WIRING .50D X .31ID X .5L	8	
13	9514	LIGHT, LICENSE PLATE	2	
14	10019	NUT, NYLOC 10-32	4	
15#	10133	NUT, NYLOC 3/8-16	8	
16	EE45318	WHEEL ASSY., ST175/80 D13, LOAD RATE C	2	
17	29158	REFLECTOR, AMBER, PETERSON B491A	2	
18	29228	COUPLER, 2" BALL 6000#GVWR	1	
19	29242	LIGHT, TAIL RT (CURB) SIDE(M440)	1	
20	29243	LIGHT, TAIL LT (ROAD) SIDE(M440L)	1	
21	29248	SCREW, HHC 9/16-18 X 3.0, AXLE MOUNT	2	
22	29249	NUT, HEX AXLE 9/16-18 N-2	2	
23	29496	JACK, SIDEWIND 10", BOLT-ON 1/2 PIN	1	
24	29563	LIGHT, 2" ROUND AMBER M146A	2	
25	29564	GROMMET/WIRE KIT, 2", 24146-18K	2	
26	29572	CHAIN ASSY., SAFETY 7600 LB	2	
27	29784	HARNESS, TRLR, 48" LOOM	1	
30	5065 B	SCREW, PHP 10-32 X 1/2	4	
31	60018	WIRE, 16 GA. BROWN, SAE J1128	3	
32	29754	KIT, HARDWARE, FENDER MOUNT .....	1	INCLUDES ITEMS W/#
33	29755	KIT, HARDWARE, LUG NUT	1	
34	2764	BAG, OPERATION AND PARTS MANUAL	1	

# TRAILER ASSY. (QP4TKT16/QP4TKT28)

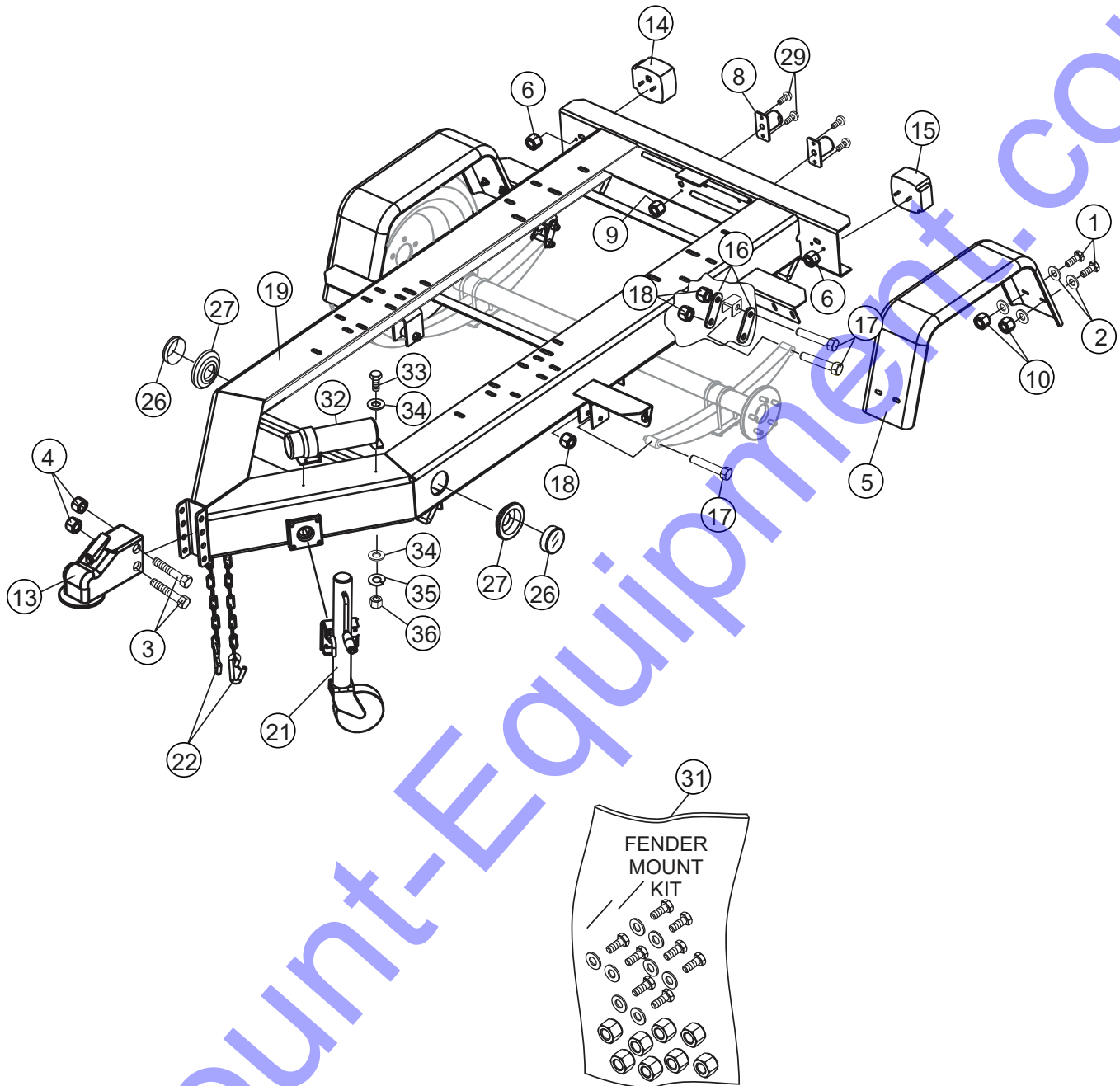

## TRAILER ASSY. (QP4TKT16/QP4TKT28)

<u>NO.</u>	<u>PART NO.</u>	<u>PART NAME</u>	<u>QTY.</u>	<u>REMARKS</u>
1	0205	SCREW, HHC 3/8-16 X 1	8	
2	4001	WASHER, FLAT USS 3/8 PLD	16	
3	9502	SCREW, HHC 5/8-11 X 4-1/2 GRD 8	2	
4	9503	NUT, NYLOC 5/8-11	2	
5	9505	FENDER, 8 X 30 X 13	2	
6\$%		NUT.....	4	NOT SOLD SEPARATELY
8	9514	LIGHT ASSY., LICENSE PLATE	2	
9	10019	NUT, NYLOC 10-32	4	
10	10133	NUT, NYLOC 3/8-16	8	
13	29228	COUPLER, 2" BALL 600# GVWR	1	
14	29242	LIGHT, TAIL RT (CURB) SIDE M440	1	INCLUDES ITEMS W/ \$
15	29243	LIGHT, TAIL LT (ROAD) SIDE M440L	1	INCLUDES ITEMS W/ %
16	29247	SHACKLE, AXLE MOUNTING	4	
17	29248	SCREW, HHC 9/16-18	6	
18	29249	NUT, 9/16-18 AXLE MOUNTING, N-2	6	
19	29370	FRAME, W/ A TRLRMP	1	
21	29496	JACK, SIDEWIND 10", BOLT THRU	1	
22	29572	CHAIN ASSY., SAFETY 7600 LB	2	
26	29898	LIGHT, 2-1/2 SIDE MARKER, AMBER, 143A	2	
27	29900	GROMMET W/ WIRE KIT, 2-1/2", 14248K	2	
29	5065 B	SCREW, PHP 10-32 X 1/2	4	
31	29754	FENDER MOUNT KIT	1	
32	23297	MANUAL HOLDER, PICTOGRAPH SAE J232	1	
33	0202	SCREW, HHC 5/16-18 X 1	2	
34	0300 B	WASHER, FLAT 5/16 MED.	4	
35	0161 C	WASHER, LOCK 5/16 MED.	2	
36	5283	NUT, 5/16 X 18	2	

# AXLE ASSY.

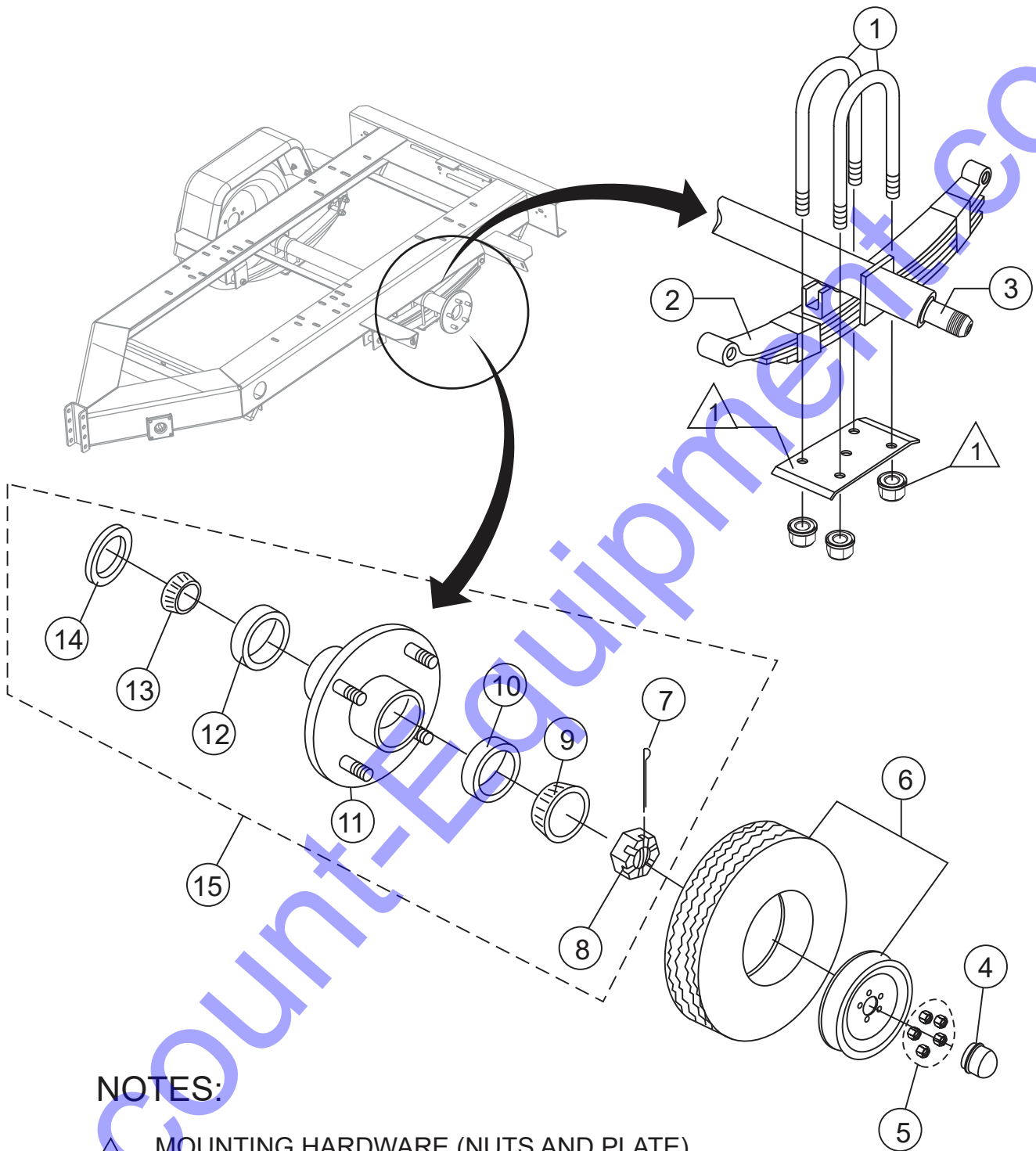

## NOTES:



MOUNTING HARDWARE (NUTS AND PLATE) INCLUDED WITH U-BOLTS (ITEM 1).

**AXLE ASSY.**

<u>NO.</u>	<u>PART NO.</u>	<u>PART NAME</u>	<u>QTY.</u>	<u>REMARKS</u>
1	29381U	KIT, U-BOLT	4	
2	29381S	SPRING, 4 LEAF 25.25	2	
3	29381B	AXLE BEAM	1	
4	46749	DUST CAP.....	2.....	HENDERSON
5	29755	LUG NUT KIT	1	
6	EE45318	WHEEL ASSY., ST175/80 D13	2	
7%	491688	COTTER PIN	1	
8%	114	SPINDLE NUT.....	1.....	HENDERSON
9%	L44649	OUTER BEARING CONE.....	1.....	HENDERSON
10%	L44610	OUTER BEARING CUP.....	1.....	HENDERSON
11%	10-215S	IDLER HUB, 5 X 4.5".....	1.....	HENDERSON
12%	L68111	INNER BEARING CUP.....	1.....	HENDERSON
13%	L68149	INNER BEARING CONE.....	1.....	HENDERSON
14%	58846	GREASE SEAL.....	1.....	HENDERSON
15	29381H	HUB KIT.....	1.....	INCLUDES ITEMS W/%

# LIFTING BAIL ASSY. (QP4TKT16/QP4TKT28)

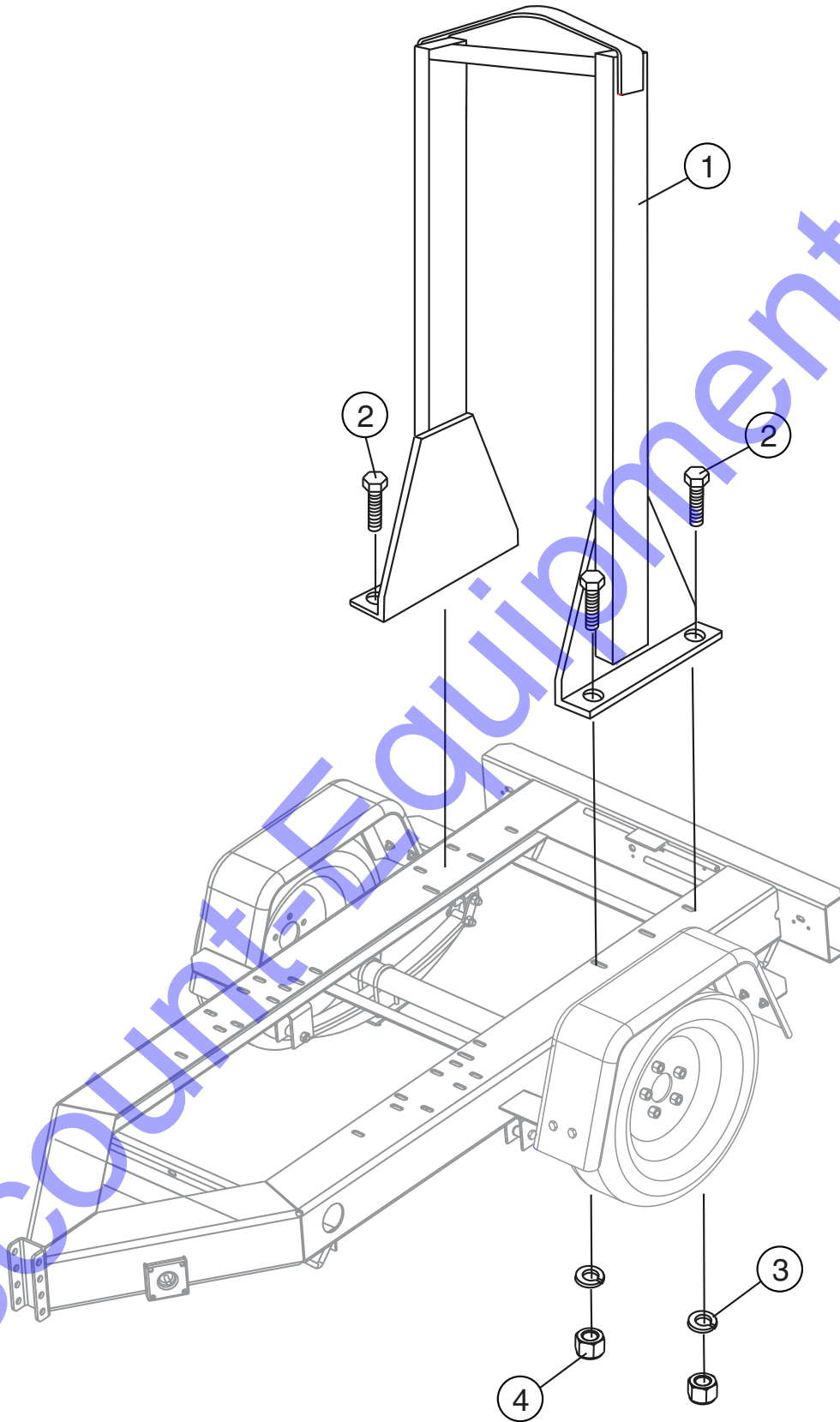

## LIFTING BAIL ASSY. (QP4TKT16/QP4TKT28)

---

<u>NO.</u>	<u>PART NO.</u>	<u>PART NAME</u>	<u>QTY.</u>	<u>REMARKS</u>
1	MPQ102	LIFTING BAIL	1	
2	0105051640	BOLT 3/4-10 X 2 GRD 8	4	
3	030216400	WASHER, 3/4	4	
4	020316130	NUT, 3/4 X 10	4	



# FUEL ASSY. (QP4TKT16)

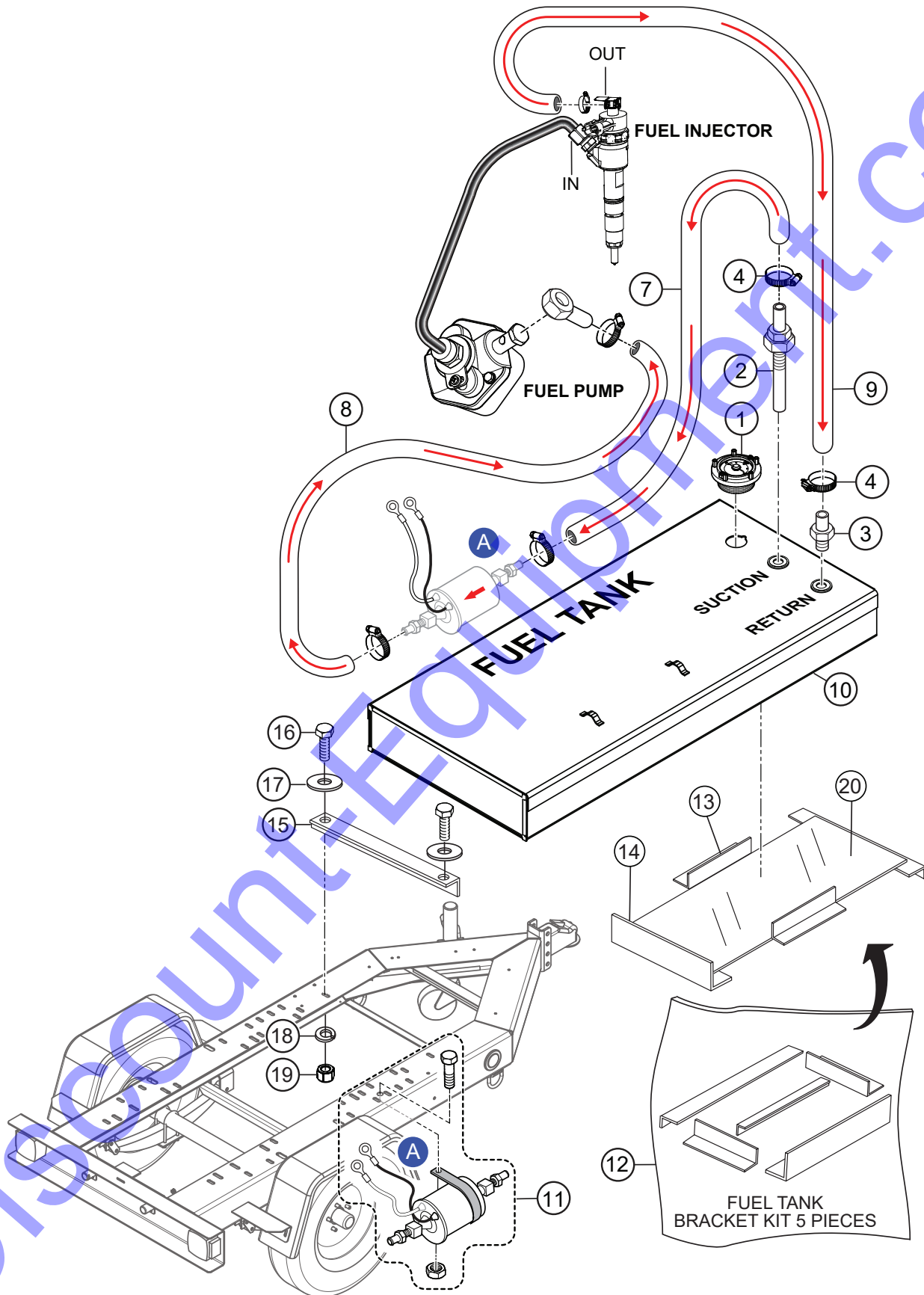

## FUEL ASSY. (QP4TKT16)

<u>NO.</u>	<u>PART NO.</u>	<u>PART NAME</u>	<u>QTY.</u>	<u>REMARKS</u>
1	19340	FUEL GAUGE	1	
2	19089	TUBE, TANK SUCTION	1	
3	19086	FITTING, STR-1/4MP	1	
4	6109152	CLAMP	6	
7	6635BULK	FUEL HOSE 5/16, 23"	1	
8	6635BULK	FUEL HOSE 5/16, 32"	1	
9	6635BULK	FUEL HOSE 3/16, 80"	1	
10	19029	TANK, FUEL 16 GAL.	1	
11	EM14401	FUEL PUMP	1	
12	ANGLEKIT16F	ANGLE KIT .....	1	INCLUDES ITEMS W/#
13	34577#	ANGLE, 2 X 2 X 1/8 X 13" MILD BLACK STEEL	2	
14	34590#	ANGLE, 2 X 2 X 1/8 X 32" MILD BLACK STEEL	2	
15	34591#	ANGLE, 1 X 1 X 1/8 X 26" MILD BLACK STEEL	1	
16	0202	BOLT, 5/16 X 18 X 1	2	
17	3233	WASHER, FENDER 3/8 X 1-1/2"	2	
18	0161 C	WASHER, LOCK 5/16 MED.	2	
19	2105164	NUT, 5/16-18	2	
20	34592	SHEET, STEEL 1/16 X 45 X 15-3/4 IN.	1	

# FUEL ASSY. (QP4TKT28)

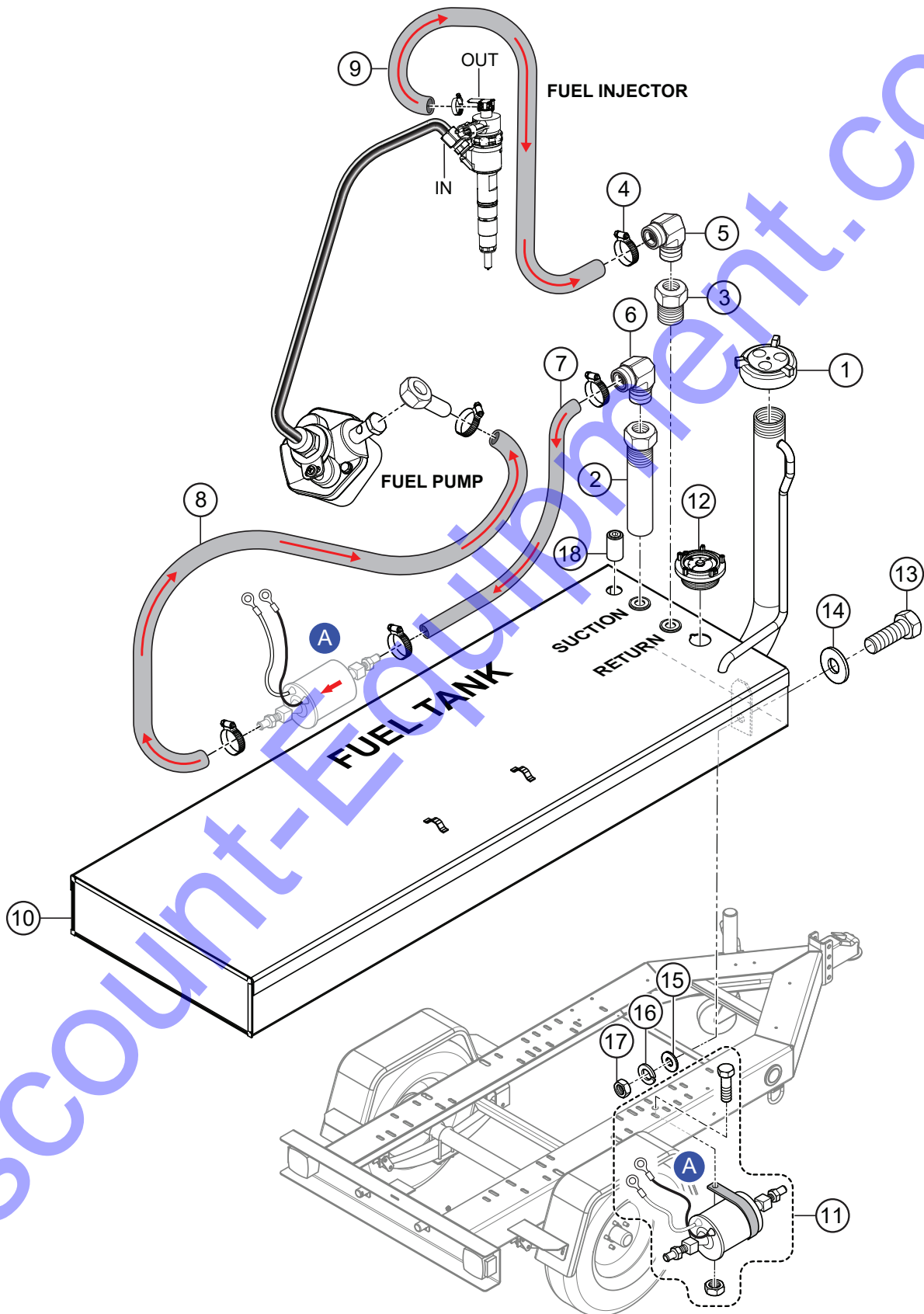

## FUEL ASSY. (QP4TKT28)

<u>NO.</u>	<u>PART NO.</u>	<u>PART NAME</u>	<u>QTY.</u>	<u>REMARKS</u>
1	7V3177002	CAP	1	
2	PICKUPTUBE	PICK UP TUBE	1	
3	5284	BUSHING, HEX PIPE 3/8 X 1/4" BRASS	1	
4	6109152	CLAMP	6	
5	6109204	FITTING, HOSE	1	
6	84454	ELBOW BRASS 1/4 MALE NPT	2	
7	60028	FUEL HOSE 5/16, 23"	1	
8	6635BULK	FUEL HOSE 5/16, 32"	1	
9	6635BULK	FUEL HOSE 3/16, 80"	1	
10	EE55144	TANK, FUEL 28 GAL.	1	
11	EM14401	FUEL PUMP	1	
12	31223FG	FUEL GAUGE	1	
13	6109210	BOLT, 1/2-13 X 1-1/2"	2	
14	13211	WASHER, FLAT 1/2 X 1-1/4 USS	2	
15	6109170	WASHER, FLAT 1/2 X 1	2	
16	6109810	WASHER, LOCK 1/2"	2	
17	6109160	NUT, 1/2"	2	
18		PLUG	1	

# PUMP AND BATTERY MOUNTING ASSY. (QP4TKT10)

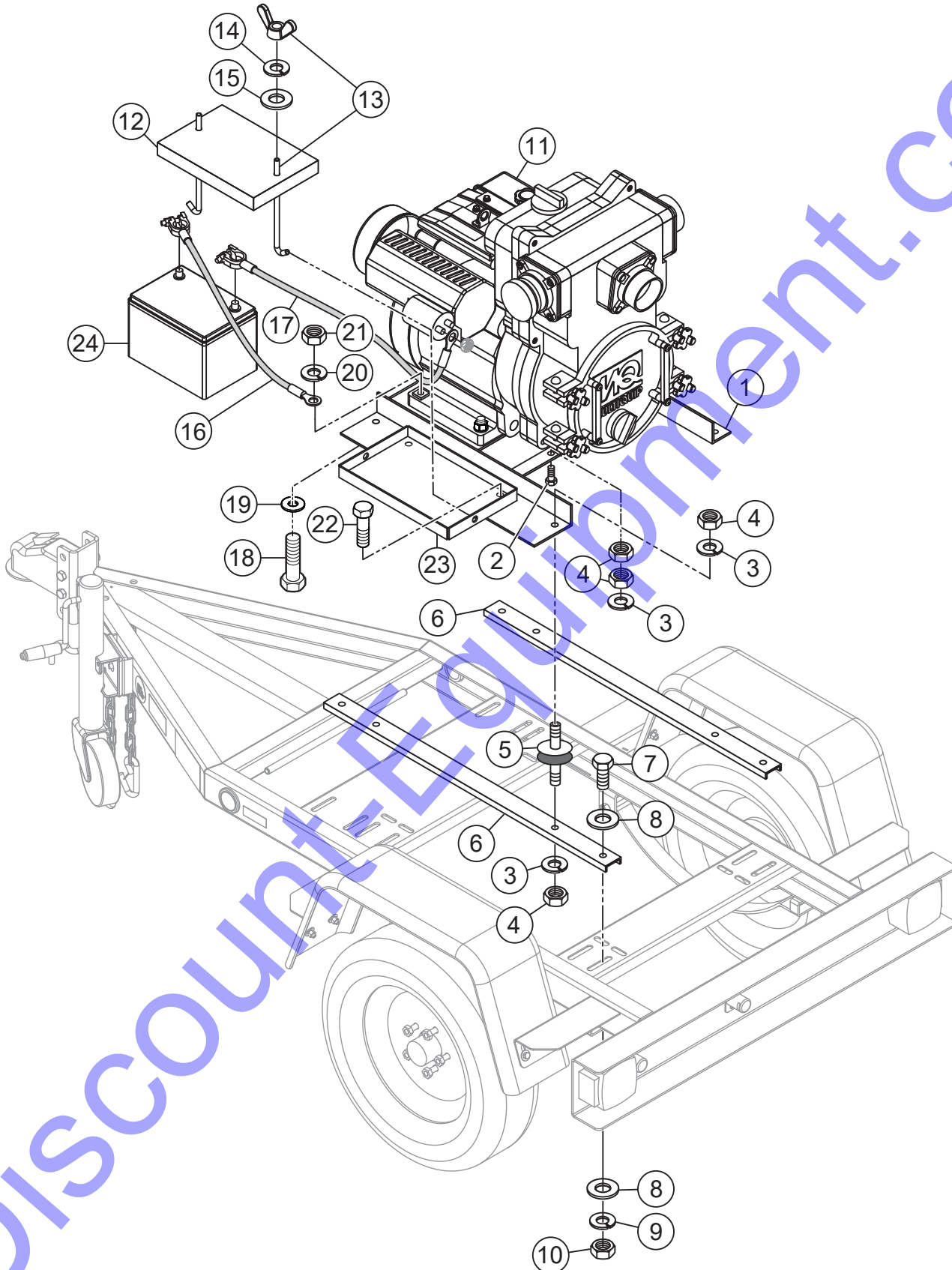

## PUMP AND BATTERY MOUNTING ASSY. (QP4TKT10)

<u>NO.</u>	<u>PART NO.</u>	<u>PART NAME</u>	<u>QTY.</u>	<u>REMARKS</u>
1	TBD	BASE, ENGINE	1	
2	0105051040	BOLT, M10 X 40 (PUMP)	2	
3	0451250100	WASHER, SPRING M10 (PUMP)	10	
4	0205450100	NUT, M10	12	
5	0723302546	CUSHION RUBBER	4	
6	29175	BRACKET, CHANNEL	2	
7	6109184	BOLT, HEX 1/2-13 X 2-1/2	4	
8	6109170	WASHER, FLAT 1/2"	8	
9	6109180	WASHER, LOCK 1/2"	4	
10	6109160	NUT, HEX 1/2-13	4	
11	TBD	ENGINE, KUBOTA OC95-E4	1	
12	09592250000014	BATTERY COVER	1	
13	0950241265A0002	BATTERY BOLT W/NUT .....	2	INCLUDES ITEMS W/#
14#	0451250080	LOCK WASHER	2	
15#	0401450080	WASHER (BATTERY)	2	
16	0975209300	NEGATIVE BATTERY CABLE	1	
17	0976209450	POSITIVE BATTERY CABLE	1	
18	0105051045	BOLT, ENGINE	4	
19	031110160	WASHER, ENGINE	4	
20	0451250100	LOCK WASHER (ENGINE)	4	REPLACES P/N 0451290100
21	020310080	NUT, ENGINE	4	REPLACES P/N 0205450100
22	0105051225	BOLT (BATTERY TRAY)	2	
23	09592280000014	BATTERY TRAY	1	
24	10315	BATTERY, 12V GROUP 24, WET	1	

# BATTERY ASSY. (QP4TKT16/QP4TKT28)

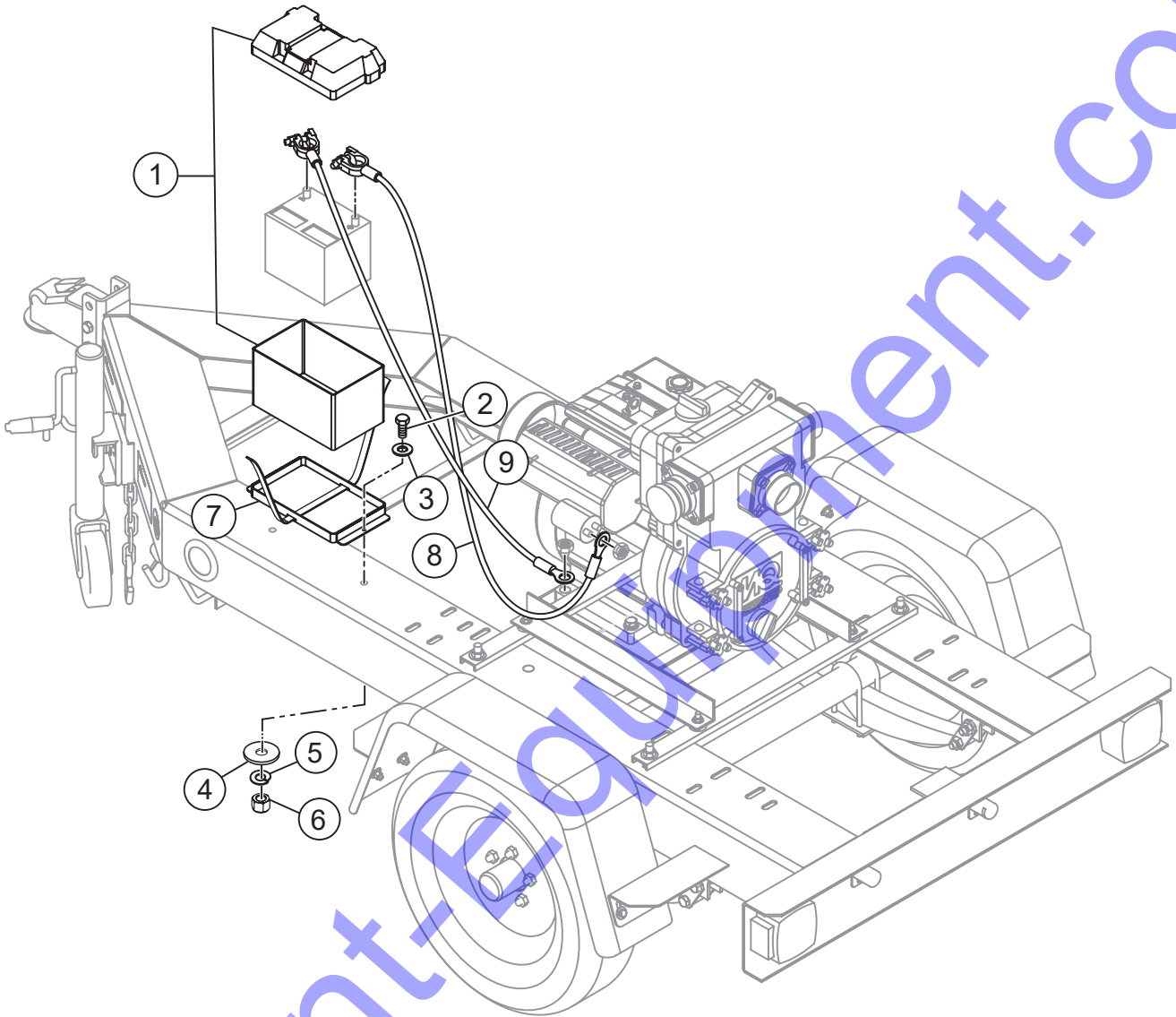

## BATTERY ASSY. (QP4TKT16/QP4TKT28)

<u>NO.</u>	<u>PART NO.</u>	<u>PART NAME</u>	<u>QTY.</u>	<u>REMARKS</u>
1	34506	BATTERY BOX	1	
2	0202	SCREW, HHC 5/16-18 X 1	2	
3	0300 B	WASHER, FLAT 5/16 MED.	2	
4	3233	WASHER, FENDER 3/8 X 1-1/2	2	
5	0161 C	WASHER, LOCK 5/16 MED.	2	
6	2105164	NUT, 5/16 X 18	2	
7	34584	BRACKET, BATTERY	1	
8	34597	POSITIVE BATTERY CABLE	1	
9	34596	NEGATIVE BATTERY CABLE	1	



# PUMP MOUNTING ASSY. (QP4TKT16/QP4TKT28)

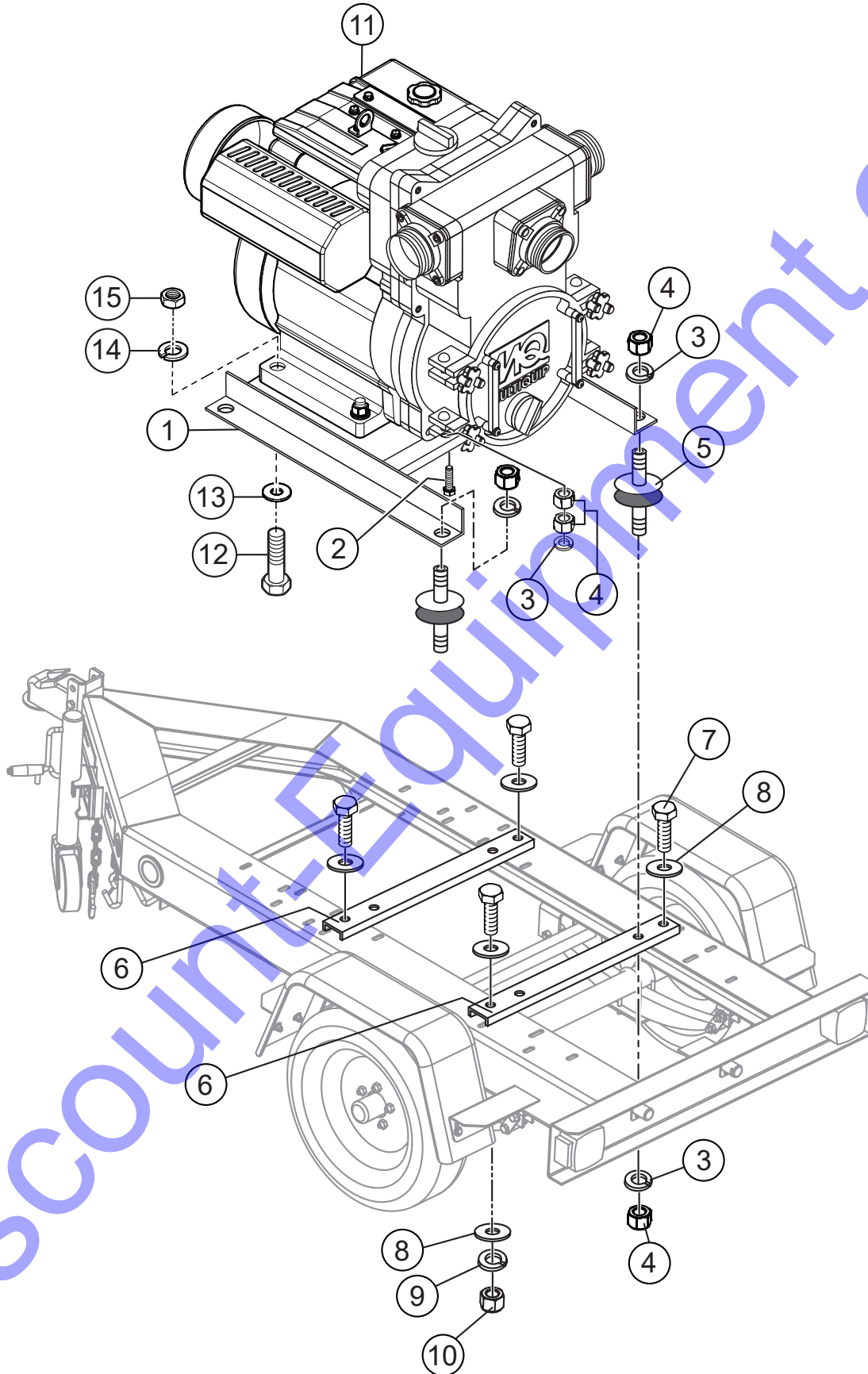

## PUMP MOUNTING ASSY. (QP4TKT16/QP4TKT28)

<u>NO.</u>	<u>PART NO.</u>	<u>PART NAME</u>	<u>QTY.</u>	<u>REMARKS</u>
1	TBD	BASE, ENGINE	1	
2	0105051040	BOLT (PUMP), M10 X 40	2	
3	0451250100	WASHER, LOCK M10	10	
4	0205450100	NUT, M10	12	
5	0723302546	CUSHION RUBBER	4	
6	29175	BRACKET, CHANNEL	2	
7	6109184	BOLT, HEX 1/2-13 X 2-1/2	4	
8	6109170	WASHER, FLAT 1/2"	8	
9	6109180	WASHER, LOCK 1/2"	4	
10	6109160	NUT, HEX 1/2-13	4	
11	TBD	ENGINE, KUBOTA OC95-E4	1	
12	0105051045	BOLT, ENGINE	4	
13	031110160	WASHER, ENGINE	4	REPLACES P/N 0401450100
14	0451250100	LOCK WASHER (ENGINE)	4	REPLACES P/N 0451290100
15	020310080	NUT, ENGINE	4	REPLACES P/N 0205450100

# ENGINE SERVICE PARTS

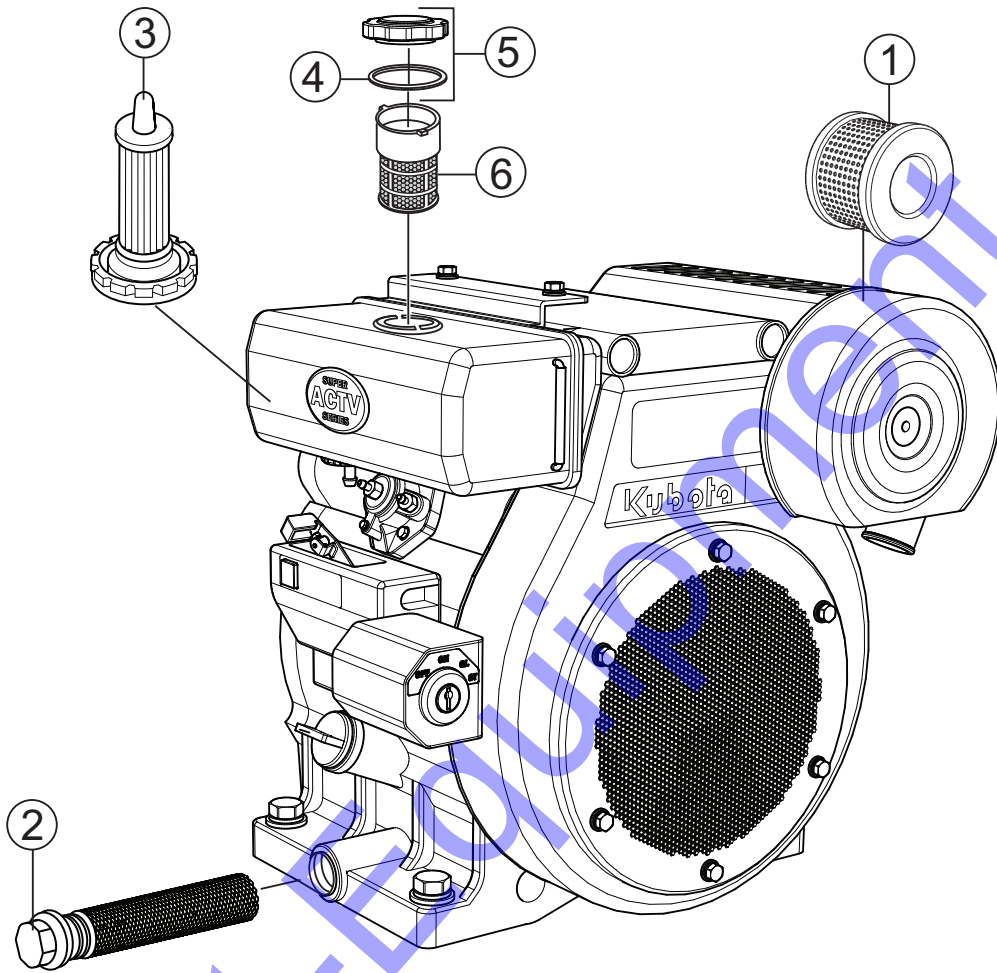

## ENGINE SERVICE PARTS

<u>NO.</u>	<u>PART NO.</u>	<u>PART NAME</u>	<u>QTY.</u>	<u>REMARKS</u>
1	1142011180	AIR FILTER	1	
2	1491132110	OIL FILTER	1	
3	1142043012	FUEL FILTER	1	
4#	1390141340	GASKET	1	
5	1142041030	CAP, FUEL TANK.....	1.....	INCLUDES ITEM W#
6	1390141350	FUEL STRAINER	1	

# **Discount Equipment**

Discount-Equipment.com is your online resource for commercial and industrial quality parts and equipment sales.

## **Locations:**

Florida (West Palm Beach): [561-964-4949](tel:561-964-4949)

Outside Florida TOLL FREE: [877-690-3101](tel:877-690-3101)

**Need parts?** Check out our website at [www.discount-equipment.com](http://www.discount-equipment.com)

## **Can't find what you need?**

Click on this link: <http://www.discount-equipment.com/category/5443-parts/> and fill out the request form.

Please have the machine model and serial number available in order to help us get you the correct parts. One of our experienced staff members will get back to you with a quote for the right part that your machine needs.

We sell worldwide for the brands: Genie, Terex, JLG, MultiQuip, Mayco, Toro/Stone, Diamond Products, Magnum, Airman, Mustang, Power Blanket, Nifty Lift, Atlas Copco, Chicago Pneumatic, Allmand Brothers, Essick, Miller Spreader, Skyjack, Lull, Skytrak, Tsurumi, Husquyarna/Target, Whiteman-Concrete/Mortar, Stow-Concrete/Mortar, Baldor, Wacker, Sakai, Snorkel, Upright, Mi-T-M, Sullair, Neal, Basic, Dynapac, MBW, Weber, Bartell, Bennar Newman, Haulotte, Ditch Runner, Blaw-Knox, Himoinsa, Best, Buddy, Crown, Edco, Wyco, Bomag, Laymor, Terremite, Barreto, EZ Trench, Takeuchi, Basic, Bil-Jax, Curtis, Gehl, Heli, Honda, ICS/PowerGrit, Puckett, Waldon, ASV, IHI, Partner, Imer, Clipper, MMD, Koshin, Rice, Gorman Rupp, CH&E, Cat Pumps, Comet, General Pump, Giant, AMida, Coleman, NAC, Gradall, Square Shooter, Kent, Stanley, Tamco, Toku, Hatz, Kohler, Robin, Wisconsin, Northrock, Oztec, Toker TK, Rol-Air, Small Line, Wanco, Yanmar