

OPERATION AND PARTS MANUAL



MODEL QP-2TZ TRASH PUMP (Diesel Engine)



www.discount-equipment.com

Revision #0 (03/25/05)

**THIS MANUAL MUST ACCOMPANY
THE EQUIPMENT AT ALL TIMES.**

Discount Equipment

Discount-Equipment.com is your online resource for commercial and industrial quality parts and equipment sales.

Locations:

Florida (West Palm Beach): [561-964-4949](tel:561-964-4949)

Outside Florida TOLL FREE: [877-690-3101](tel:877-690-3101)

Need parts? Check out our website at www.discount-equipment.com

Can't find what you need?

Click on this link: <http://www.discount-equipment.com/category/5443-parts/> and fill out the request form.

Please have the machine model and serial number available in order to help us get you the correct parts. One of our experienced staff members will get back to you with a quote for the right part that your machine needs.

We sell worldwide for the brands: Genie, Terex, JLG, MultiQuip, Mayco, Toro/Stone, Diamond Products, Magnum, Airman, Mustang, Power Blanket, Nifty Lift, Atlas Copco, Chicago Pneumatic, Allmand Brothers, Essick, Miller Spreader, Skyjack, Lull, Skytrak, Tsurumi, Husquyarna/Target, Whiteman-Concrete/Mortar, Stow-Concrete/Mortar, Baldor, Wacker, Sakai, Snorkel, Upright, Mi-T-M, Sullair, Neal, Basic, Dynapac, MBW, Weber, Bartell, Bennar Newman, Haulotte, Ditch Runner, Blaw-Knox, Himoina, Best, Buddy, Crown, Edco, Wyco, Bomag, Laymor, Terremite, Barreto, EZ Trench, Takeuchi, Basic, Bil-Jax, Curtis, Gehl, Heli, Honda, ICS/PowerGrit, Puckett, Waldon, ASV, IHI, Partner, Imer, Clipper, MMD, Koshin, Rice, Gorman Rupp, CH&E, Cat Pumps, Comet, General Pump, Giant, AMida, Coleman, NAC, Gradall, Square Shooter, Kent, Stanley, Tamco, Toku, Hatz, Kohler, Robin, Wisconsin, Northrock, Oztec, Toker TK, Rol-Air, Small Line, Wanco, Yanmar



WARNING

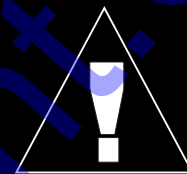

CALIFORNIA — Proposition 65 Warning

Engine exhaust and some of its constituents are known to the State of California to cause cancer, birth defects and other reproductive harm.

MQ QP-2TZ Trash Pump

Hatz 1B20 Diesel Engine

Here's How To Get Help	3	Spare Parts Kit Assembly	32-33
Table of Contents	4	Accessories Assembly	34-35
Parts Ordering Procedures	5	Crankcase and Engine Mount Assembly	36-37
Safety Message Alert Symbols	6-7	Crankshaft Assembly	38-39
Rules For Safe Operation	8-9	Camshaft Assembly	40-41
Pump Specifications/Dimensions	10	Piston Assembly	42-43
Engine Specifications	11	Cylinder Head Assembly	44-45
General Information	12	Oil Pump/Governor Assembly	46-49
Pump Components	13	Timing Cover Assembly	50-51
Refueling	14	Flywheel Assembly	52-53
Basic Engine	15	Fuel Injection Assembly	54-57
Pre-Inspection (Engine)	16	Recoil Starter Assembly	58-59
Pre-Setup (Pump)	17	Air Duct Assembly	60-63
Initial Start-up (Engine)	18	Crankcase Breather Assembly	64-65
Maintenance (Pump)	19-20	Fuel Tank Assembly	66-67
Maintenance (Engine)	21-22	Air Filter Assembly	68-69
Preparation for Long-Term Storage	23	Muffler Assembly	70-71
Troubleshooting (Engine)	24	Sealing and Bonding Adhesives	72
Troubleshooting (Pump)	25		
Explanation Of Code In Remarks Column	26	Terms and Condition Of Sale — Parts	73
Suggested Spare Parts	27		
Pump Assy.	28-31		

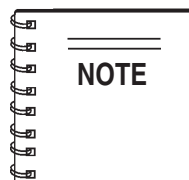

Specification and part number are subject to change without notice.

QP-2TZ — SAFETY MESSAGE ALERT SYMBOLS

FOR YOUR SAFETY AND THE SAFETY OF OTHERS!

Safety precautions should be followed at all times when operating this equipment. Failure to read and understand the Safety Messages and Operating Instructions could result in injury to yourself and others.

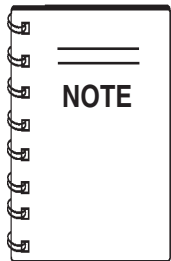

This Owner's Manual has been developed to provide complete instructions for the safe and efficient operation of the Multiquip **Model QP-2TZ Trash Pump**. Refer to the engine manufacturers instructions for data relative to its safe operation. **Before using this pump, ensure that the operating individual has read and understands all instructions in this manual.**

SAFETY MESSAGE ALERT SYMBOLS

The three (3) Safety Messages shown below will inform you about potential hazards that could injure you or others. The Safety Messages specifically address the level of exposure to the operator, and are preceded by one of three words: **DANGER**, **WARNING**, or **CAUTION**.

DANGER

You **WILL** be **KILLED** or **SERIOUSLY INJURED** if you **DO NOT** follow these directions.

WARNING

You **CAN** be **KILLED** or **SERIOUSLY INJURED** if you **DO NOT** follow these directions.

CAUTION

You **CAN** be **INJURED** if you **DO NOT** follow these directions.

Potential hazards associated with the QP-2TZ Trash Pump operation will be referenced with Hazard Symbols which appear throughout this manual, and will be referenced in conjunction with Safety Message Alert Symbols.

HAZARD SYMBOLS

Lethal Exhaust Gases



Engine exhaust gases contain poisonous carbon monoxide. This gas is colorless and odorless, and can cause death if inhaled. **NEVER** operate this equipment in a confined area or enclosed structure that does not provide ample free flow air.

Explosive Fuel



GASOLINE is extremely flammable, and its vapors can cause an explosion if ignited. **DO NOT** start the engine near spilled fuel or combustible fluids. **DO NOT** fill the fuel tank while the engine is running or hot. **DO NOT** overfill tank, since spilled fuel could ignite if it comes into contact with hot engine parts or sparks from the ignition system. Store fuel in approved containers, in well-ventilated areas and away from sparks and flames. **NEVER**

Burn Hazards



Engine components can generate extreme heat. To prevent burns, **DO NOT** touch these areas while the engine is running or immediately after operations. Never operate the engine with heat shields or heat guards removed.

Rotating Parts



NEVER operate equipment with covers, or guards removed. Keep fingers, hands, hair and clothing away from all moving parts to prevent injury.

QP-2TZ — SAFETY MESSAGE ALERT SYMBOLS



Accidental Starting



OFF

ALWAYS place the engine ON/OFF switch in the **OFF** position when the pump is not in use.



Respiratory Hazard



ALWAYS wear approved respiratory protection.



Sight and Hearing hazard

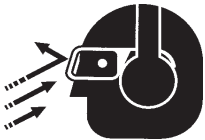

ALWAYS wear approved eye and hearing protection.



Equipment Damage Messages

Other important messages are provided throughout this manual to help prevent damage to your pump, other property, or the surrounding environment.

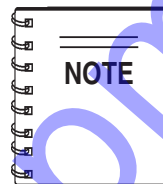

This pump, other property, or the surrounding environment could be damaged if you do not follow instructions.

RULES FOR SAFE OPERATION

DANGER

Failure to follow instructions in this manual may lead to serious injury or even death! This equipment is to be operated by trained and qualified personnel only! This equipment is for industrial use only.

The following safety guidelines should always be used when operating the **trash pump**:

GENERAL SAFETY

- **DO NOT** operate or service this equipment before reading this entire manual.



- This equipment should not be operated by persons under 18 years of age.
- **NEVER** operate this equipment without proper protective clothing, shatterproof glasses, steel-toed boots and other protective devices required by the job.



- **NEVER** operate this equipment when not feeling well due to fatigue, illness or taking medicine.



- **NEVER** operate this equipment under the influence of drugs or alcohol.



- Whenever necessary, replace nameplate, operation and safety decals when they become difficult read.
- **ALWAYS** check the machine for loosened threads or bolts before starting.
- **ALWAYS** wear proper respiratory (mask) hearing and eye protection equipment when operating the pump.



- **NEVER** touch the hot exhaust manifold, muffler or cylinder. Allow these parts to cool before servicing engine or pump.



- **High Temperatures** – Allow the engine to cool before adding fuel or performing service and maintenance functions. Contact with *hot* components can cause serious burns.

- The engine of this pump requires an adequate free flow of cooling air. **NEVER!** operate the pump in any enclosed or narrow area where free flow of the air is restricted. If the air flow is restricted it will cause serious damage to the pump or engine and may cause injury to people and property. Remember the pump's engine gives off **DEADLY** gases.

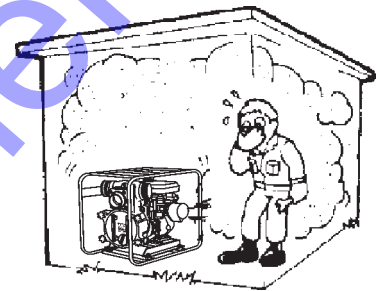

- **ALWAYS** refuel in a well-ventilated area, away from sparks and open flames.

- **ALWAYS** use extreme caution when working with **flammable** liquids. When refueling, **stop the engine** and allow it to cool. **DO NOT** smoke around or near the machine. Fire or explosion could result from fuel vapors, or if fuel is spilled on a hot engine.

- **NEVER** operate the pump in an **explosive atmosphere** or near combustible materials. An explosion or fire could result causing severe **bodily harm or even death**.



- Topping-off to filler port is dangerous, as it tends to spill fuel.

- Refer to the **Engine Owner's Manual** for engine technical questions or information.

- **NEVER** use accessories or attachments, which are not recommended by Multiquip for this equipment. Damage to the equipment and/or injury to user may result.

- Manufacturer does not assume responsibility for any accident due to equipment modifications.

RULES FOR SAFE OPERATION

- **NEVER** Run engine without air cleaner. Severe engine damage may occur.
- **ALWAYS** read, understand, and follow procedures in Operator's Manual before attempting to operate equipment.
- **ALWAYS** be sure the operator is familiar with proper safety precautions and operation techniques before using pump.
- **ALWAYS** store equipment properly when it is not being used. Equipment should be stored in a clean, dry location out of the reach of children.
- **NEVER** leave the pump unattended, turn off engine when unattended.
- Unauthorized equipment modifications will void all warranties.
- **NEVER** pump volatile, explosive, flammable or low flash point fluids. These fluids could ignite or explode.
- **NEVER** operate the pump in an **explosive** atmosphere.
- Before starting the pump, check that the clean-out cover is securely fasten.
- **ALWAYS** ensure pump is on level ground before use.
- Become familiar with the components of the pump before operating.
- **NEVER** pump corrosive chemicals or water containing toxic substances. These fluids could create serious health and environmental hazards. Contact local authorities for assistance.
- **NEVER** open the priming plug when pump is hot. Hot water inside could be pressurized much like the radiator of an automobile. Allow pump to cool to the touch before loosening plug.
- **NEVER** open the pump housing during operation or start the pump with the clean-out cover removed. The rotating impeller inside the pump can cut or sever objects caught in it.
- **NEVER** block or restrict flow from discharge hose. Remove kinks from discharge line before starting pump. Operation with a blocked discharge line can cause water inside pump to overheat.
- **ALWAYS** fill the pump casing with water before starting the engine. Failure to maintain water inside the pump housing will cause severe damage to the pump.
- In winter drain water from pump housing to prevent freezing.

- **High Temperatures** – Always stop engine and allow the engine to cool before adding fuel, oil or performing service and maintenance functions. Contact with *hot* components can cause serious burns.
- **NEVER** disconnect any "**emergency or safety devices**". These devices are intended for operator safety. Disconnection of these devices can cause severe injury, bodily harm or even death! Disconnection of any of these devices will void all warranties.

Maintenance Safety

- **NEVER** lubricate components or attempt service on a running machine.
- **ALWAYS** allow the machine a proper amount of time to cool before servicing.
- Keep the machinery in proper running condition.
- Fix damage to the machine immediately and always replace broken parts, or missing decals.
- Dispose of hazardous waste properly. Examples of potentially hazardous waste are used motor oil, fuel and fuel filters.
- **DO NOT** use food or plastic containers to dispose of hazardous waste.
- **DO NOT** pour waste, oil or fuel directly onto the ground, down a drain or into any water source.

Emergencies

- **ALWAYS** know the location of the nearest **fire extinguisher**.



- **ALWAYS** know the location of the nearest **first aid kit**.



- In emergencies **always** know the location of the nearest phone or **keep a phone on the job site**. Also know the phone numbers of the nearest **ambulance, doctor and fire department**. This information will be invaluable in case of an emergency.



QP-2TZ — SPECIFICATIONS/DIMENSIONS (PUMP)

Table 1. Specifications (Pump)		
Pump	Model	QP-2TZ
	Type	Trash Pump
	Suction & Discharge Size	2.00 in. (50 mm.)
	Maximum Pumping Capacity	198 gallons/minute (750 liters/minute)
	Max. Solids Diameter	1.50 in. (25.4 mm.)
	Max. Lift	25 ft. (7.62 meters)
	Max. Head	95 ft. (29.0 meters)
Dimension (L x W x H)	26.5 x 18.3 X 23.2 in. (67.5 X 46.5 X 59.0 cm.)	
Dry Net Weight	131 lbs. (59.5 Kg.)	

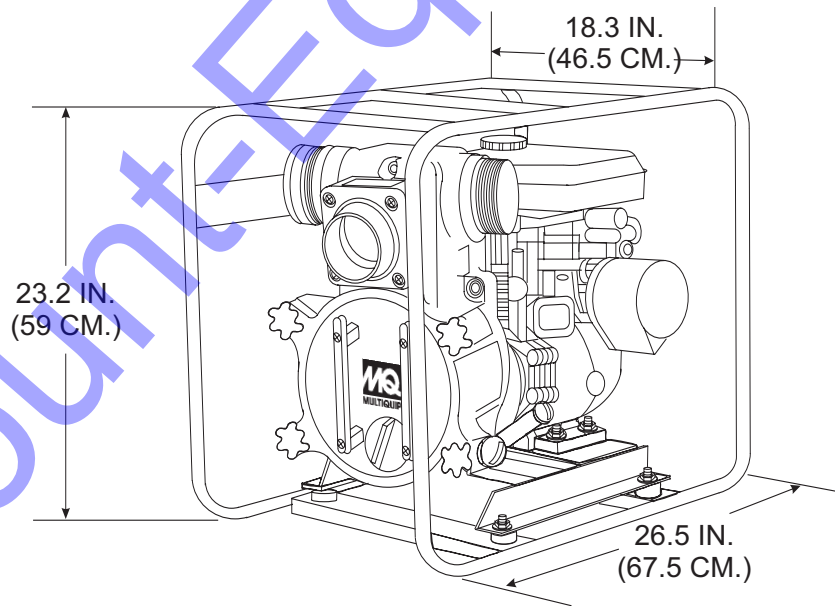
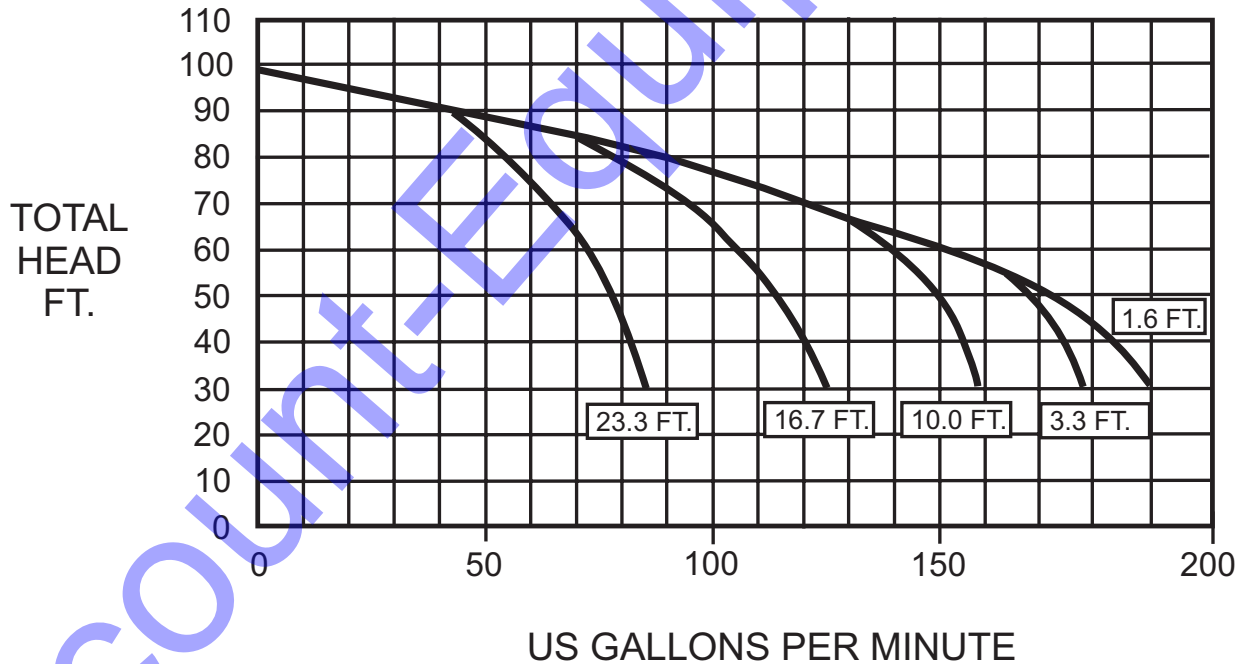

Figure 1. QP-2TZ Dimensions

QP-2TZ — SPECIFICATIONS (ENGINE)

Table 2. Engine Specifications (HATZ 1B20)

HATZ Diesel Model 1B20 Air-Cooled	No. Cylinders	Displacement	Idle Speed	Lube Oil Capacity	Type Air Cleaner	Starting Method	Weight
	1	14.5 in ³ (.232 liters)	800 RPM	0.95 qts. (0.9 liters)	Dry Element	Recoil Start	72 lbs. (33 kg.)
Engine Oil Type	CCMC - D4 - D5 - PD@ or API - CD-CE - CF -CG or SHPD						
Type Fuel	EN 590 - DIN 51601 BS 2869 A1/A2-ASTM D 975-1D/2D						



QP-2TZ — GENERAL INFORMATION

APPLICATION

The **QP-2TZ Trash Pump** is designed to be used for dewatering applications. Both the suction and discharge ports on the QP-2TZ trash pump use a 2-inch diameter opening, which allows the pump to pump at a rate of approximately 211 gallons/minute (gpm) or 800 liters/minute (lpm).

Trash or self-priming pumps are designed to purge air from the suction line and create a partial vacuum in the pump body. The reduced atmospheric pressure inside the pump allows water to flow through the suction line and into the pump body. The centrifugal force created by the rotating impeller pressurizes the water and expels it from the pump.

Engine

This trash pump is powered by a 4.6 horsepower, air-cooled, **HATZ 1B20** diesel engine.

Trash Pump

Trash pumps derive their name from their ability to handle a greater amount of debris and solids than standard centrifugal pumps. This pump generally handle solids up to 1/2 the size of the discharge opening making them less likely to clog. Also trash pumps are capable of handling water with 25% solids by weight.

The advantage of using a trash pump is that it can be quickly and easily disassembled in the field "**without tools**" and easily cleaned when clogged.

Suction Lift

This pump is intended to be used for dewatering applications and is capable of suction lifts up to 25 feet at sea level. For optimal suction lift performance, keep the suction hose or line as short as possible. In general, always place the pump as close to the water as possible.

Pump Support

The pump should always be placed on **solid stationary ground** in a level position.

NEVER place the pump on **soft soil**. The suction hose or pipe connection should always be checked for tightness and leaks. A small suction leak in the hose or fittings could prevent the pump from priming.

Elevation

Higher elevations will effect the performance of the pump. Due to less atmospheric pressure at higher altitudes, pumps **DO NOT** have the priming ability that they have at sea level. This is due to the "thinner air" or lack of oxygen at higher altitudes.

A general rule of thumb is that for every 1,000 feet of elevation above sea level a pump will lose one foot of priming ability.

For example, in Flagstaff, Arizona where the elevation is approximately 7,000 feet, the pump would have a suction lift of 25 feet rather than the 18 feet at sea level. Table 3 shows suction lift at various elevations.

Table 3. Suction Lift at Various Elevations

Altitude Feet (Meters)	Suction Lift in Feet (Meters)			
	Sea Level	10.0 (3.048)	15.0 (4.572)	20.0 (6.096)
2,000 (610)	8.80 (2.680)	13.2 (4.023)	17.6 (5.364)	22.0 (6.705)
4,000 (1,219)	7.80 (2.377)	11.7 (3.566)	15.6 (4.754)	19.5 (5.943)
6,000 (1,829)	6.90 (2.103)	10.4 (3.169)	13.8 (4.206)	17.3 (5.273)
8,000 (2,438)	6.20 (1.889)	9.30 (2.834)	12.4 (3.779)	15.5 (4.724)
10,000 (3,048)	5.70 (1.737)	8.60 (2.621)	11.4 (3.474)	14.3 (4.358)

Table 4 shows percentage drops in performance as elevation increases.

Table 4. Performance Loss at Various Elevations

Altitude Feet (Meters)	Discharge Flow	Discharge Head
Sea Level	100%	100%
2,000 (610)	97%	95%
4,000 (1,219)	95%	91%
6,000 (1,829)	93%	87%
8,000 (2,438)	91%	83%
10,000 (3,048)	88%	78%

QP-2TZ — PUMP COMPONENTS

Figure 2 shows a typical application using the QP-2TZ Trash pump. Please note that this pump is intended for the removal of clean water and water containing some debris and solids. Maximum size of solids should not exceed 1.0 inch (25 mm) in diameter. **DO NOT** set strainer on bottom of water bed. Placing the strainer above the water bed will prevent the pump from drawing in excessive amounts of sand and foreign debris.

Figure 2. QP-2TZ Pump Application

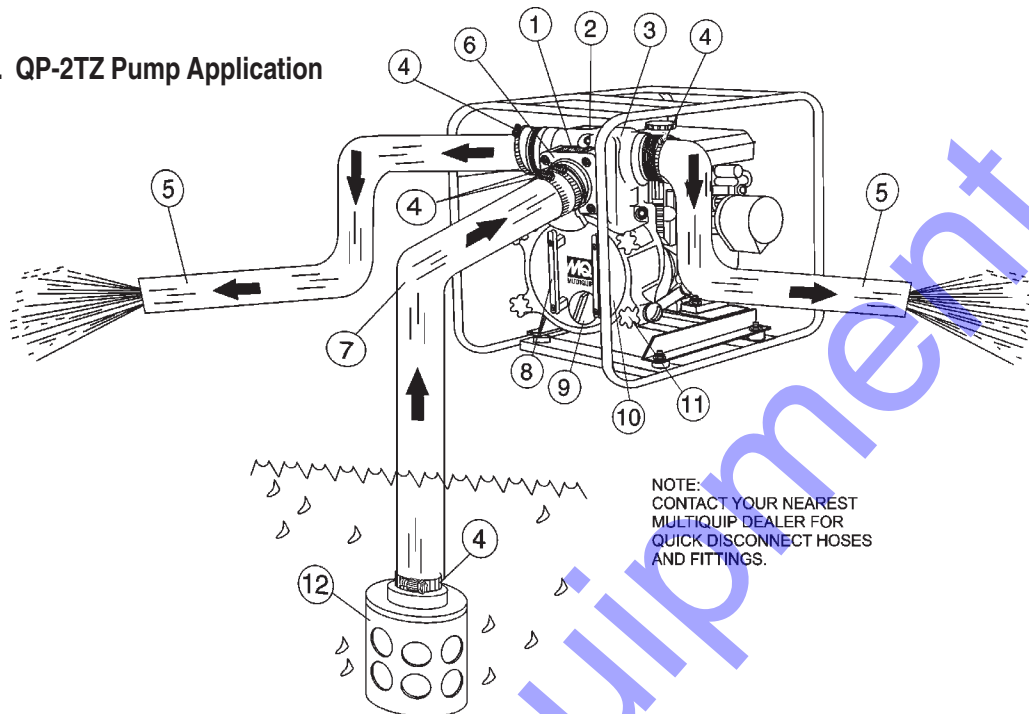

1. **Pump** – The model QP-2TZ is a 2-inch trash pump used in general dewatering applications. Typical dewatering applications consist of manholes, septic tanks, fast and slow seepage ditch water, silt water, mud water and muck water.
2. **Fill Cap** – Prior to operation, the pump casing should be filled with water. Remove this cap to add water to the pump. After the initial prime, a sufficient amount of water will be retained in the casing so that the operator will not need to re-prime later.
If the casing is dry or has insufficient water, the pump will have difficulty in priming which could lead to premature mechanical seal wear thus causing damage to the pump.
3. **Discharge Port** – Connect a 2-inch discharge hose to this port.
4. **Worm Clamp** – Used to secure the hose to the inlet and outlet ports on the pump. Use two clamps to secure the hose on the inlet side of the pump.
5. **Discharge Hose** – Connect this flexible rubber hose to the discharge port on the pump. Make sure that the hose lays flat and is not kinked. Use only recommended type discharge hose. Contact Multiquip Parts Department for ordering information.
6. **Suction Port** – Connect a 2-inch inlet hose to this port. Use two worm clamps to secure the hose.
7. **Suction Hose** – Connect this flexible rubber hose to the suction portion the pump. Make sure that the hose lays flat and is not kinked. Use only recommended type suction hose. Contact Multiquip Parts Department for ordering information.
8. **Clean-out Cover Handles** – To gain access to the pump's clean-out area, grip both handles, then pull to remove cover. Make sure both locking knobs have been released before attempting to remove clean-out cover.
9. **Drain Plug** – Remove this plug to drain water from the pump.
10. **Clean-out Cover** – Remove cover to gain access to the clean-out area.
11. **Locking Knobs** – Turn both knobs clockwise to secure clean-out cover, turn counterclockwise to release cover.
12. **Strainer** – Always attach a strainer to the bottom side of the suction hose to prevent large objects and debris from entering the pump. Strainer should be positioned so that it will remain completely under water. Running the pump with the strainer above water for long periods can damage pump.



! DANGER

Adding fuel to the tank should be done only when the engine is stopped and has had an opportunity to cool down. In the event of a fuel spill, **DO NOT** attempt to start the engine until the fuel residue has been completely wiped up, and the area surrounding the engine is dry. If pump is placed in a truck bed with a plastic liner, **REMOVE** pump from truck bed and place on ground (Figure 3) to refuel. The possibility of *fire* or *explosion* exists, due to static electricity.

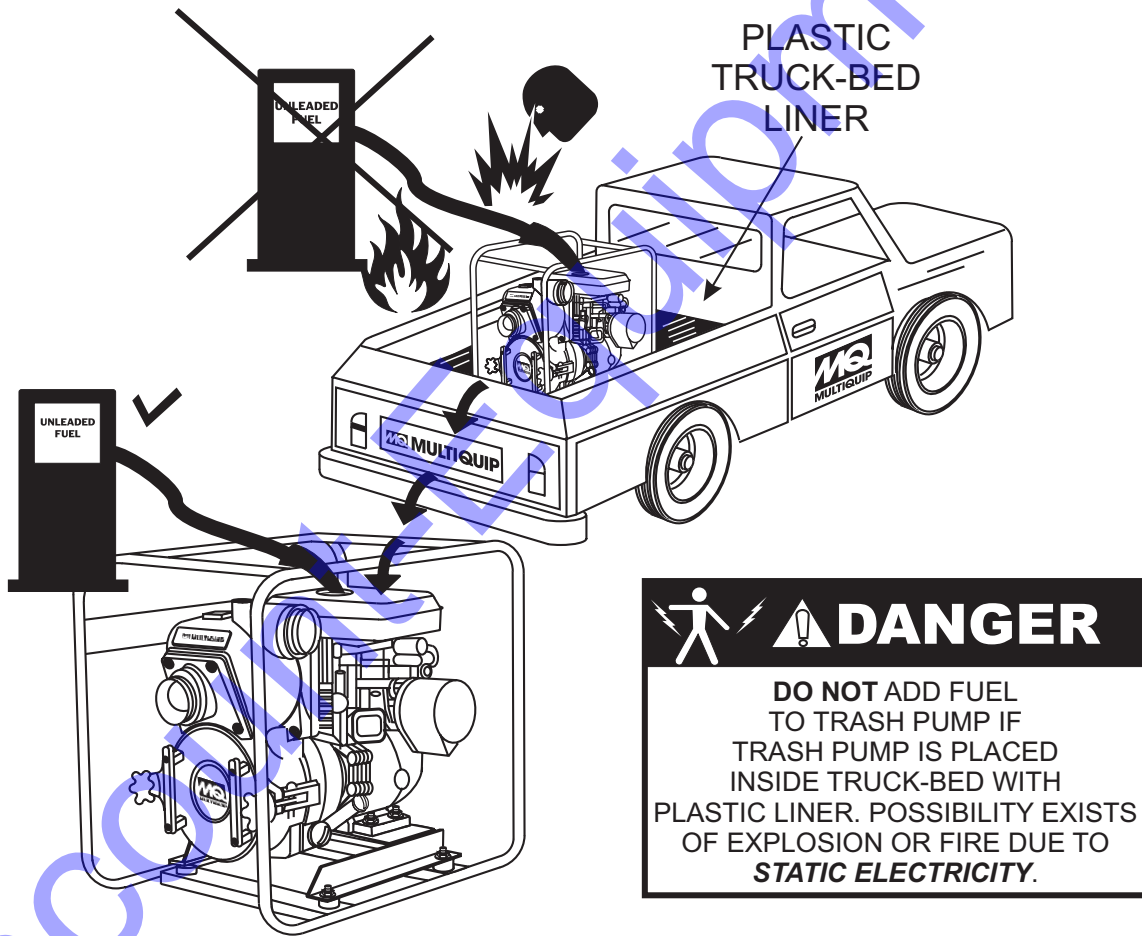

Figure 3. Pump Refueling

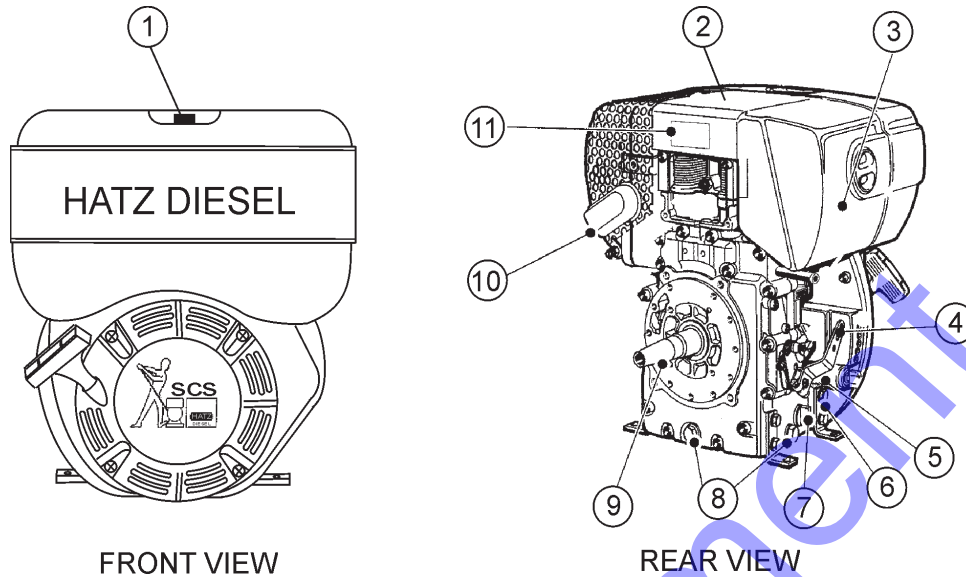

Figure 4. Engine Controls and Components

INITIAL SERVICING

The engine (Figure 4) must be checked for proper lubrication and filled with fuel prior to operation. Refer to the manufacturer's Engine manual for instructions & details of operation and servicing.

1. **Fuel Filler Cap/Fuel Tank** – Pull this latch to add *diesel* fuel to the tank. After refueling, always make sure the fuel cap is latched properly. **DO NOT** over fill. For additional information refer to engine owner's manual.



WARNING

Adding fuel to the tank should be accomplished only when the engine is stopped and has had an opportunity to cool down. In the event of a fuel spill, **DO NOT** attempt to start the engine until the fuel residue has been completely wiped up, and the area surrounding the engine is dry.

2. **Engine Lifting Straps/Cover** – Remove the air cleaner cover, then lift this cover (the one with decals on it) to gain access to the engine lifting straps.
3. **Air Cleaner/Cover** – Prevents dirt and other debris from entering the fuel system. Remove wing-nut on side of air filter cover to gain access to filter element.
4. **Speed Control Lever** – This lever is connected to the throttle control which is located on the side of the engine compartment cover. Use this lever to control engine speed.
5. **Dip Stick** – Remove dipstick to determine if the engine oil level is low. If low add oil as specified.

6. **Engine Motor Mounts** – Attach these engine mounts to the pump frame. Tighten securely.
7. **Oil Filter** – Remove this bolt to gain access (internal) to the engine oil filter. Service the oil filter as recommended in the maintenance section of this manual.
8. **Oil Drain Plugs** – There are two oil drain plugs, one is underneath the flywheel, the other on the side of the engine. Remove these plugs to drain engine oil from the engine crankcase.
9. **Crankshaft** – Connect this shaft to the input of the transmission.
10. **Muffler** – Used to reduce noise and emissions.
11. **Nameplate** – Contains information about the engine.



WARNING

Engine components can generate extreme heat. To prevent burns, **DO NOT** touch these areas while the engine is running or immediately after operating. **NEVER** operate the engine with the muffler removed.

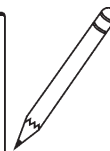
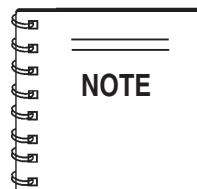

Operating the engine without an air filter, with a damaged air filter, or a filter in need of replacement will allow dirt to enter the engine, causing rapid engine wear.

QP-2TZ — PRE-INSPECTION (ENGINE)

CAUTION



NEVER operate the pump in a confined area or enclosed area structure that does not provide ample **free flow of air**.

ALWAYS wear approved eye and hearing protection before operating the pump.



Before Starting

1. Read safety instructions at the beginning of manual.
2. Clean the pump, removing dirt and dust, particularly the engine cooling air inlet, carburetor and air cleaner.
3. Check the air filter for dirt and dust. If air filter is dirty, replace air filter with a new one as required.
4. Check carburetor for external dirt and dust. Clean with dry compressed air.
5. Check fastening nuts and bolts for tightness.



Engine Oil Check

1. To check the engine oil level, place the pump on secure level ground with the engine stopped.
2. Remove the filler dipstick from the engine oil filler hole (Figure 5) and wipe clean.

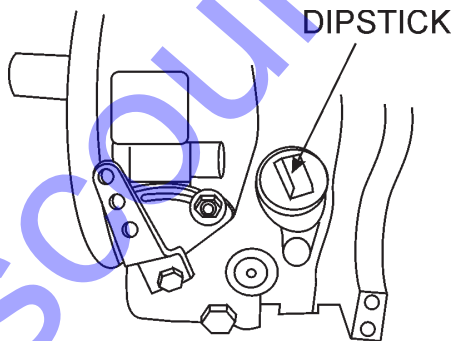

Figure 5. Engine Oil Dipstick (Removal)

3. Insert and remove the dipstick without screwing it into the filler neck. Check the oil level shown on the dipstick.
4. If the oil level is low (Figure 6), fill to the edge of the oil filler hole with the recommended oil type (Table 5). Maximum oil capacity is 1.16 quarts (1.1 liters)

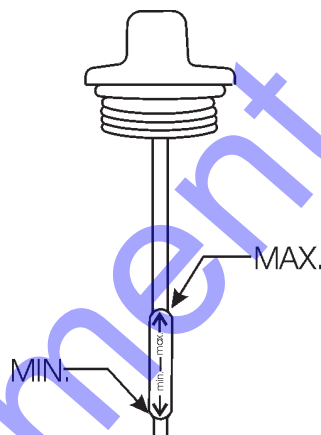

Figure 6. Engine Oil Dipstick (Oil Level)

Table 5. Oil Type

Season	Temperature	Oil Type
Summer	25°C or Higher	SAE 10W-30
Spring/Fall	25°C~10°C	SAE 10W-30/20
Winter	0°C or Lower	SAE 10W-10

Explosive Fuel



DANGER

Motor fuels are highly flammable and can be dangerous if mishandled. **DO NOT** smoke while refueling. **DO NOT** attempt to refuel the pump if the engine is **hot!** or **running**.

Fuel Check

1. Remove the gasoline cap located on top of fuel tank.
2. Visually inspect to see if the fuel level is low. If fuel is low, replenish with unleaded fuel.
3. When refueling, be sure to use a strainer for filtration. **DO NOT** top-off fuel. Wipe up any spilled fuel **immediately!**

Before Starting

1. Read safety instructions at the beginning of manual.
2. Place pump as near to water as possible, on a firm flat, level surface.
3. To prime pump, remove fill cap (Figure 2) and fill pump casing with water. If the pump casing is not filled with water before starting, it will not begin pumping.

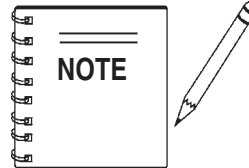

Suction and discharge hoses are available from Multiquip. Contact your nearest dealer for more information.

CAUTION

Pump casing **must** be filled with water before using pump. Otherwise pump will not be able to begin pumping.

WARNING

DO NOT open **fill cap** if pump is **hot!** Water inside may be under pressure.

4. Check for **leaks** between pump and engine. If water is leaking between the pump and engine housing, the seal inside the pump may be worn or damaged. Continued operation of the pump is not recommended. Further usage of the pump under these conditions may cause severe water damage to engine.

Hoses and Clamps

1. Check that all hoses are **securely** attached to the pump. Make certain suction hose (Figure 2) does not have any air leakage. Tighten hose clamps and couplings as required.
2. It is recommended that 2 clamps be used when securing the suction hose to the inlet side (suction) of the pump.
3. Remember suction hoses must be **rigid** enough not to collapse when the pump is in operation.
4. Check that the **discharge** hose (Figure 2) is not restricted. Place hose so that it lays as straight as it is possible on the ground. Remove any twists or sharp bends from hose which may block the flow of water.

5. The discharge hose is usually a **collapsible** (thin-walled) hose, however if a thin-walled discharge hose is not available, a rigid suction hose can be substituted in its place.
6. Make sure the **suction strainer** (Figure 2) is clean and securely attached to the water end of the suction hose. The strainer is designed to protect the pump by preventing large objects from being pulled into the pump.

CAUTION

The strainer should be positioned so it will remain completely **under water**. Running the pump with the strainer above water for long periods can damage the pump.

CAUTION

DO NOT pump flammable fluids, corrosive chemicals or fluids containing toxic substances. These fluids can create potentially dangerous health and environmental hazards. Contact local authorities for assistance.

CAUTION

This pump uses a water-cooled **mechanical seal** to prevent water from seeping into the engine. The passage of water through the pump casing lubricates the seal and prevents it from overheating. **NEVER!** operate the pump without water in the casing as this will cause damage to the mechanical seal.

QP-2TZ — INITIAL START-UP (ENGINE)

CAUTION



DO NOT attempt to operate the pump until the Safety, General Information and Inspection sections of this manual have been *read and thoroughly understood*.

This section is intended to assist the operator with the *initial start-up* of the trash pump. It is extremely important that this section be read carefully before attempting to use the pump in the field.

Starting the Engine (HATZ engine)

3. Move the engine speed lever to the **START** position (Figure 8).

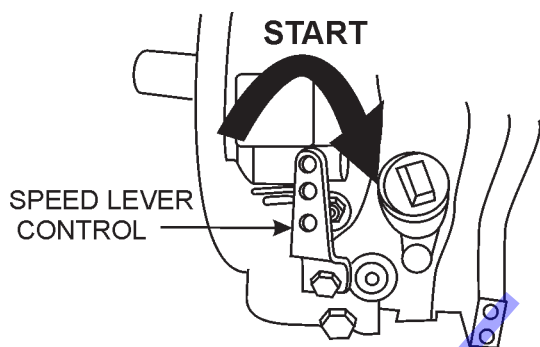

Figure 8. Engine Speed Lever (START position)

4. Grasp the starter grip (Figure 9) and slowly pull it out until you feel the strongest resistance then return the starter grip to the initial position.

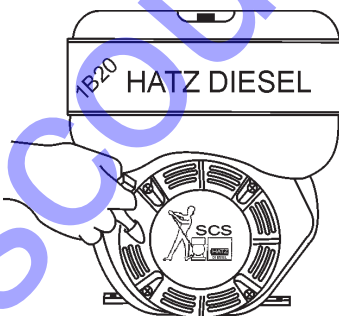

Figure 9. Starter Grip

CAUTION

Do not allow the starter grip to snap back against the engine. Return it gently to prevent damage to the starter.

5. Pull the starter grip again, hard and fast, pulling it all the way out to start engine.
6. If the engine does not start, repeat steps 4 and 5.

CAUTION

ALWAYS run engine at *full speed* while pumping.

Stopping The Engine

Normal Shutdown

1. Move the engine speed lever to the low speed and run the engine for about three minutes with no load.
2. After the engine cools, move the engine speed lever to the **STOP** position (Figure 11).

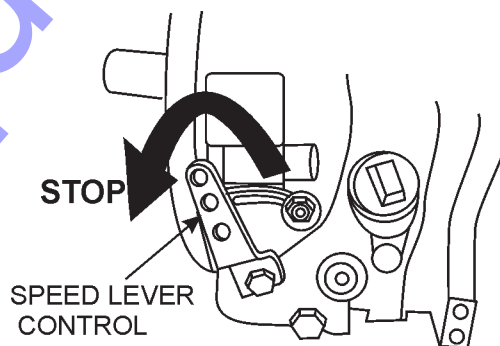

Figure 11. Engine Speed Lever (STOP Position)

4. Slowly pull the starter grip (Figure 9) until strong resistance is felt and leave it in this position. This prevents rust from forming while the engine is not in use.

CAUTION

When stopping the engine, reduce the load slowly. Do not stop engine suddenly since it may cause the temperature to rise abnormally.

Emergency Shutdown

1. To stop engine immediately, quickly place the engine speed lever to the STOP position.

Pump Vacuum Test

CAUTION

DO NOT attempt to start the engine unless the pump has previously been **primed** with water. Severe pump damage will occur if pump has not been primed.

To perform the pump vacuum test do the following:

1. Remove the pump fill cap (Figure 2), and fill the pump with water.
2. Start the engine as outlined in the initial start-up section, and wait for the pump to begin pumping.
3. As shown in Figure 13, place a water hose inside the discharge opening of the pump, and turn on the water. This flow of water into the discharge opening will **prevent** the pump from running dry.
4. Place the **Pump Vacuum Tester** (P/N 7000030) over the pump suction (inlet) opening (Figure 13) with the vacuum gauge facing upwards. It may be necessary to apply a small amount of water around the rubber seal of the vacuum tester to make a good suction fit.
5. Check and make sure that there are no air leaks between the vacuum tester and the inlet port on the pump. If air leaks are present reset vacuum tester.
6. Run the pump for a few minutes while monitoring the vacuum gauge. If the gauge indicates a reading between -25 and -20 in. Hg. (inches of mercury), then it can be assumed that the pump is working correctly.

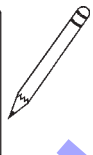
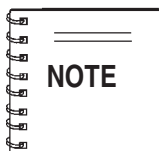

25 in. Hg. (inches of mercury) translates into 25 feet of lift at **sea level**.

7. If the vacuum tester gauge indicates a reading **below** -20 in. Hg, it can then be assumed that the pump is not functioning correctly, and corrective action needs to be taken.
6. To test the **flapper valve**, shut down the engine. The vacuum tester should remain attached to the pump suction inlet port by vacuum. This indicates the pump's flapper valve is seating properly to hold water in the suction hose when the engine is stopped. This prevents backflow and allows for faster priming when the engine is restarted.

Adjusting Impeller Clearance

1. If it is necessary to replace impeller or volute, be sure clearance between impeller and volute is adjusted correctly.
2. The impeller should be as close to the volute as possible without rubbing against it. Clearance is adjusted by adding or removing **shims** from behind the impeller.
3. Check clearance between impeller and insert by slowly pulling starter rope to turn impeller. Remove spark plug to make it easier to turn impeller.

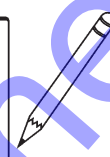
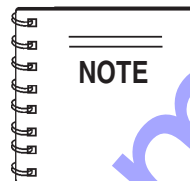

It is important not to remove too many shims or the clearance between the impeller and volute will become **too wide** and pump performance will be reduced. Remember as the impeller wears down, additional shims may be required to maintain the clearance between the impeller and insert.

4. Check the impeller **every six months** for wear, and for clearance between the impeller face and the volute. Also check the shaft seal for wear, as well as the shaft sleeve.

Pump Cleaning

After pumping water containing large amounts of dirt and debris, perform the following:

1. Remove the drain plug from the pump housing (Figure 2) and drain any water left in the pump.
2. Loosen the two locking hand knobs (turn counterclockwise) and remove **clean-out cover**.
3. Clean and remove dirt, debris from pump casing. Inspect impeller and volute for wear. Replace any damaged or worn parts.

CAUTION

The impeller may develop **sharp edges**. Use extreme care when cleaning around the impeller to prevent being cut.

CAUTION

DO NOT RUN PUMP WITHOUT WATER.

PLACE VACUUM TESTER OVER PUMP SUCTION PORT

DISCHARGE PORT

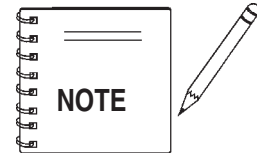
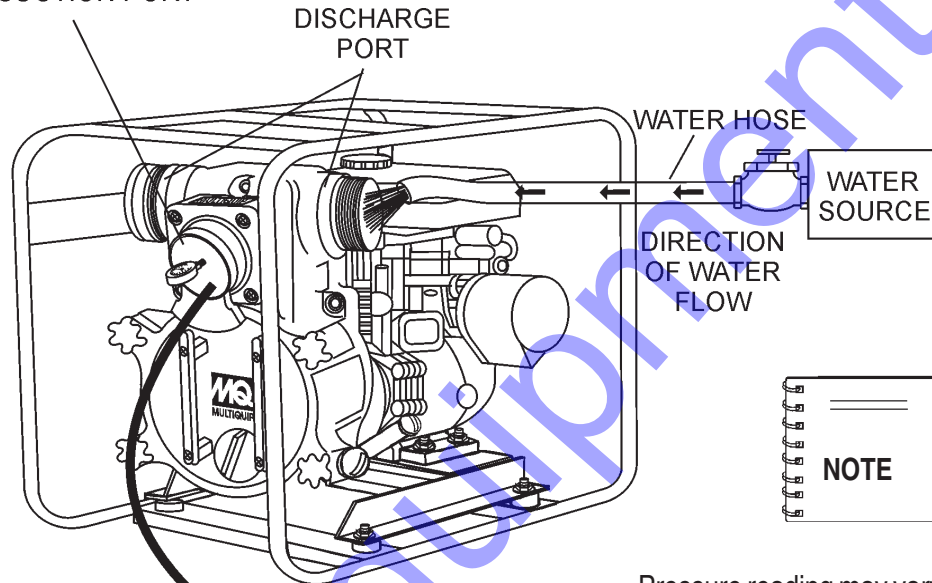

Pressure reading may vary depending on altitude. See Tables 3 and 4 on page 12.

ACCEPTABLE READING SHOULD BE BETWEEN -25 AND -20 IN. HG.

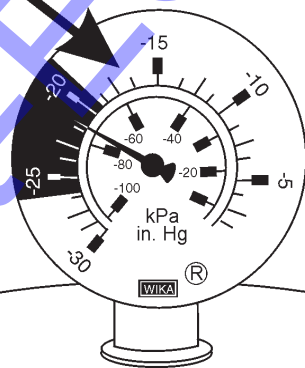

25 IN. HG. TRANSLATES INTO 25 FEET OF LIFT AT SEA LEVEL.

PUMP VACUUM TESTER

Figure 13. Pump Vacuum Tester

QP-2TZ — MAINTENANCE (ENGINE)

Engine Maintenance

Perform engine maintenance procedures as referenced by Table 6 below:

Table 6. Engine Maintenance Schedule							
DESCRIPTION (3)	OPERATION	BEFORE	FIRST MONTH OR 10 HRS.	EVERY 3 MONTHS OR 25 HRS.	EVERY 6 MONTHS OR 50 HRS.	EVERY YEAR OR 100 HRS.	EVERY 2 YEARS OR 200 HRS.
Engine Oil	CHECK	X					
	CHANGE		X				
Air Cleaner	CHECK	X					
	CHANGE			X (1)			
All Nuts & Bolts	Re-tighten If Necessary	X					
Cooling Fins	CHECK				X		
Spark Arrester	CLEAN					X	
Fuel Tank	CLEAN					X	
Fuel Filter	CHECK					X	
Idle Speed	CHECK-ADJUST					X (2)	
Valve Clearance	CHECK-ADJUST						X (2)
Fuel lines	CHECK	Every 2 years (replace if necessary) (2)					

(1) Service more frequently when used in **DUSTY** areas.

(2) These items should be serviced by your service dealer, unless you have the proper tools and are mechanically proficient. Refer to the HATZ shop manual for service procedures.

(3) For commercial use, log hours of operation to determine proper maintenance intervals.

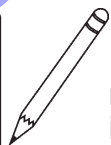
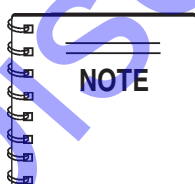

Reference manufacturer engine manual for specific servicing instructions.

Maintenance

Perform the engine maintenance procedures as indicated below:

DAILY

- Thoroughly remove dirt and oil from the engine and control area. Clean or replace the air cleaner elements as necessary. Check and retighten all fasteners as necessary. Check the spring box and bellows for oil leaks. Repair or replace as needed.

WEEKLY

- Remove the fuel filter cap and clean the inside of the fuel tank.
- Remove or clean the filter at the bottom of the tank.

ENGINE OIL

1. Drain the engine oil when the oil is **warm** as shown in Figure 14.
2. Remove the oil drain bolt and sealing washer and allow the oil to drain into a suitable container.
3. Replace engine oil with recommended type oil as listed in Table 5. Engine oil capacity is 0.95 quarts (0.9 liters). **DO NOT** overfill.
4. Install drain bolt with sealing washer and tighten securely.

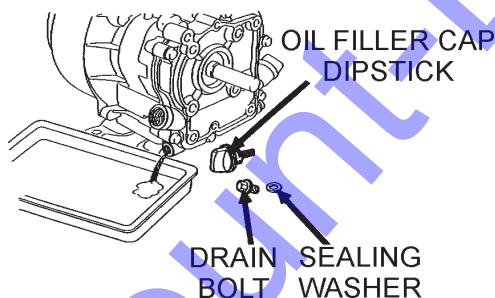

Figure 14. Engine Oil (Draining)

! DANGER

DO NOT use gasoline as a cleaning solvent, because that would create a risk of fire or explosion.

ENGINE AIR CLEANER

1. Loosen the wing nut and detach the cover of the air cleaner shown in Figure 15.
2. Tap the element (Figure 15) several times on a hard surface to remove dirt, or blow compressed air [not exceeding 30 psi (207 kPa, 2.1 kgf/cm²)] through the element side. **NEVER** wash the element with detergent because the element is oil-soaked type. Replace the element when the output decreases or bad exhaust color is noticed.

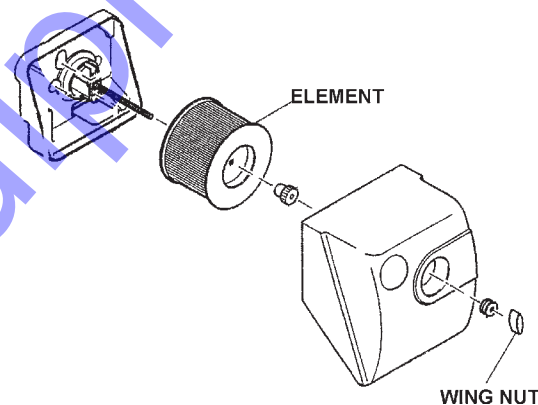

Figure 15. Engine Air Cleaner

QP-2TZ — PREPARATION FOR LONG -TERM STORAGE

Pump Storage

For storage of the pump for over 30 days, the following is required:

- Drain the fuel tank completely.
- Run the engine for about 3 minutes and then stop.
- Stop the engine. Drain the engine crankcase oil while the engine is still warm. Fill engine crankcase with fresh oil.
- Pull the recoil starter grip (Figure 17) 2 or 3 times. **DO NOT** start the engine.

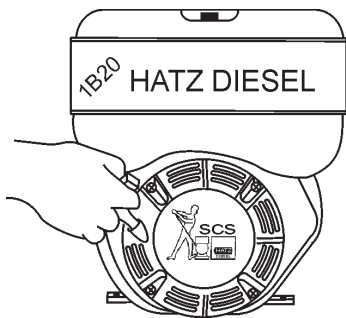

Figure 17. Recoil Starter Grip

- Pull the recoil starter grip slowly. **STOP** when it feels tight. This closes the intake and exhaust valves (compression position) , and helps prevents rust from forming.
- Wipe any oil or dirt that may have accumulated on the engine.
- Remove the drain plug from the pump and drain out any water left in the housing.
- Remove the pump cover and clean the inside of pump housing. Coat the inside of pump housing with a light film of oil to reduce corrosion. A spray can of oil works well for this application.
- Cover suction and discharge ports with duct tape to prevent any foreign matter from falling into pump.
- Cover pump and engine with plastic covering or equivalent and store in a clean, dry place.
- To protect the water cooled-seals, place one-half pint of lubricating oil (new or used) through the discharge opening on the pump and crank the engine several times. This will prevent excessive corrosion and also keep the mechanical seal lubricated.

QP-2TZ — TROUBLESHOOTING (ENGINE)

TABLE 7. ENGINE TROUBLESHOOTING

SYMPTOM	POSSIBLE PROBLEM	SOLUTION
Engine will not start or start is delayed, although engine can be turned over.	Speed control lever is in "STOP" position?	Set speed control lever to "START" position.
	No fuel reaching injection pump?	Add fuel. Check entire fuel system.
	Defective fuel pump?	Replace fuel pump.
	Fuel filter clogged?	Replace fuel filter and clean tank.
	Faulty fuel supply line?	Replace or repair fuel line.
	Compression too low?	Check piston, cylinder and valves. Adjust or repair per engine repair manual.
	Fuel injector not working correctly?	Repair or replace injector in accordance with engine repair manual.
	Oil pressure too low?	Check engine oil pressure.
	Low starting temperature limit exceeded	Comply with cold starting instructions and proper oil viscosity.
At low temperatures engine will not start.	Fuel separates has inadequate resistance to low temperatures?	Check whether clear (not turbid) fuel emerges from the fuel line (detach from injection pump). If the fuel is turbid or separated, warm up the engine or drain the complete fuel supply system. Refuel with winter grade diesel fuel.
	Engine oil too thick?	Refill engine crankcase with correct type of oil for winter environment.
Engine fires but stops soon as starter is switched off.	Fuel filter blocked?	Replace fuel filter.
	Fuel supply blocked?	Check the entire fuel system.
Engine stops by itself during normal operation.	Fuel tank empty?	Add fuel.
	Fuel filter blocked?	Replace fuel filter.
Low engine power, output and speed.	Fuel tank empty?	Fill with No.2 diesel fuel.
	Fuel filter clogged?	Replace fuel filter.
	Fuel tank venting is inadequate?	Ensure that tank is adequately vented.
	Speed control lever does not remain in selected position?	See engine manual for corrective action.
	Engine oil level too full?	Correct engine oil level?
Low engine power output and low speed, black exhaust smoke.	Air filter blocked?	Clean or replace air filter.
	Incorrect valve clearances?	Adjust valves per engine specification.
	Malfunction at injector?	See engine manual.

QP-2TZ — TROUBLESHOOTING (PUMP)

TABLE 8. PUMP TROUBLESHOOTING

SYMPTOM	POSSIBLE PROBLEM	SOLUTION
Pump does not take on water.	Not enough priming water in the housing?	Add water.
	Engine speed too low?	Increase throttle.
	Strainer plugged?	Clean strainer.
	Suction hose damaged?	Replace or repair hose, and clamps
	Air leak at suction port?	Check that fittings are tight and properly sealed.
	Pump is located too high above water line?	Move pump closer to water.
	Debris collecting in pump housing?	Clean pump housing.
	Too much distance between impeller and volute.	Adjust clearance by adding shims or replace impeller. Min. .006" - Max. .020"
	Water leaking out weep hole between pump and engine?	Check condition of mechanical seal and gaskets, between pump end and engine housing.
Pump takes in water, little or no discharge.	Engine speed too low?	Increase throttle speed.
	Suction strainer partially plugged?	Clean strainer.
	Impeller/Volute worn?	Adjust clearance by adding shims or replace impeller/volute
Suction hose leaks at inlet.	Fittings/clamps are not sealed properly?	Tighten, replace or add clamp. (Keep extra seals on pump)
	Hose diameter is too large?	Use smaller diameter hose or replace hose.
Discharge does not stay on coupling.	Pressure too high?	Check pressure, add additional clamp.
	Hose kinked or end blocked?	Check hose.
Impeller does not turn: pump is hard to start.	Impeller jammed or blocked?	Open pump cover and clean dirt and debris from inside housing.
	Impeller and volute binding?	Adjust clearance by removing shim from behind impeller.
	Defective engine?	See Engine Owner's Manual.

QP-2TZ — EXPLANATION OF CODE IN REMARKS COLUMN

How to read the marks and remarks used in this parts book.

Items Found In the “Remarks” Column

Serial Numbers-Where indicated, this indicates a serial number range (inclusive) where a particular part is used.

Model Number-Where indicated, this shows that the corresponding part is utilized only with this specific model number or model number variant.

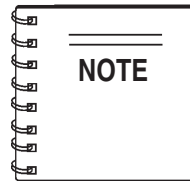

The contents of this catalog are subject to change without notice.

Items Found In the “Items Number” Column

All parts with same symbol in the number column, *, #, +, %, or ■, belong to the same assembly or kit.

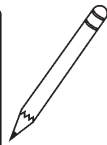
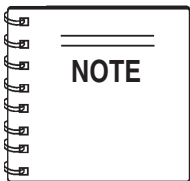

If more than one of the same reference number is listed, the last one listed indicates newest (or latest) part available.

**QP-2TZ TRASH PUMP 1 TO 3 UNITS
W/ HATZ IB20**

Qty.	P/N	Description
2	KIT2T	KIT, MECHANICAL SEAL, O-RINGS
1	2257040030	IMPELLER
2	0631211159	FLOODING CAP
3	50426000	AIR FILTER ELEMENT
1	01548800	ROPE RECOIL STARTER
1	01535302	CAP, FUEL TANK
1	01635200	FUEL FILTER, GAS TANK

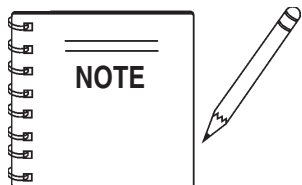

Part number on this Suggested Spare Parts List may supersede/replace the P/N shown in the text pages of this book.

QP-2TZ — PUMP ASSY.

PUMP ASSY.

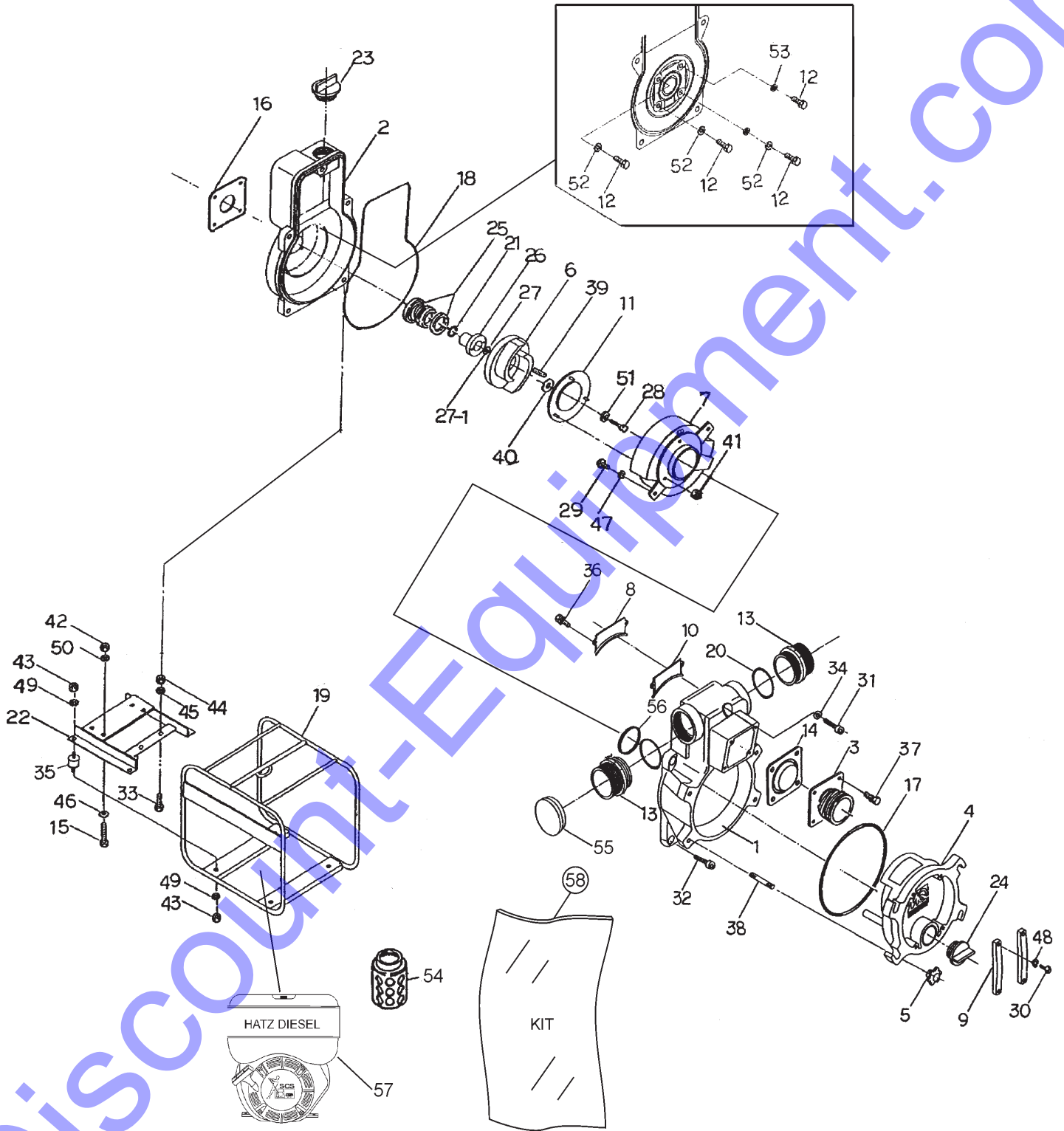

PUMP ASSY.

<u>NO.</u>	<u>PART NO.</u>	<u>PART NAME</u>	<u>QTY.</u>	<u>REMARKS</u>
1	1889100011	CASING	1	
2	1889100020	CASING COVER	1	
3	18890001600014	SUCTION COVER	1	
4	1889100171	DRAIN COVER	1	
5	19920002200014	DRAIN COVER HANDLE	4	
6	2257040030	IMPELLER	1	
7	1889000132	VOLUTE CASING	1	
8	1889100741	SUCTION PLATE	1	
9	1247100250	DRAIN COVER SET HANDLE	2	
10	1889330410	SUCTION PLATE PACKING	1	
11	1992250700	WEAR PLATE	1	
12	0105090825	BOLT (CASING COVER), M8 X 25	4	
13	07904320200014	NIPPLE, NPS2" X NPT2"	2	
14	1889350351	CHECK VALVE, NBR+SS400	1	
15	0105090825	BOLT (ENGINE), M8 X 25	4	
16	1211390610	CASING COVER PACKING, OIL SHEET, X 84	1	
17*	0481571950	O'RING (DRAIN COVER), G195	1	
18*	0489402910	O'RING (CASING)	1	
19	2257214010P002	BASE, SS400	1	
20	0481310550	O'RING (NIPPLE), G55	2	
21*	0482200180	O'RING (MECHANICAL SEAL SLEEVE), S18	1	
22	22572140200014	ENGINE BASE, SS400	1	
23	0631211159	FLOODING CAP, PF1 1/2"	1	
24	0631211159	DRAIN CAP, PF1 1/2"	1	
25*	0803442930	MECHANICAL SEAL, EH791-030-T, SIC X SIC	1	
26*	0811345443	MECHANICAL SEAL SLEEVE, 25 H43	1	
27*	0852833020	ADJUST LINER, 30 X 20 T0.3	1	
27-1*	0852853020	ADJUST LINER, 30 X 20 T0.5	1	
28	0191190525	BOLT (IMPELLER), 5/16-24 UNF X 25	1	
29	0141090820	SCREW (VOLUTE CASING), M8 X 20	2	
30	0141090825	SCREW (DRAIN COVER SET HANDLE), M8 X 25	4	
31	0131191270	CAP SCREW (CASING), M12 X 70	1	
32	0131191235	CAP SCREW (CASING), M12 X 35	4	
33	0105091055	BOLT (PUMP), M10 X 55	2	
34	0459220120	SEAL WASHER (CASING), M12, W12S1	1	
35	0723302040	CUSHION RUBBER, 40 X 20 M10, NBR+SS400	4	
36	0181090820	BOLT SET WITH SPRING WASHER (SUCTION COVER) M8 X 20	2	
37	0181090825	BOLT SET WITH SPRING WASHER (SUCTION COVER) M8 X 25	4	

QP-2TZ — PUMP ASSY.

PUMP ASSY.

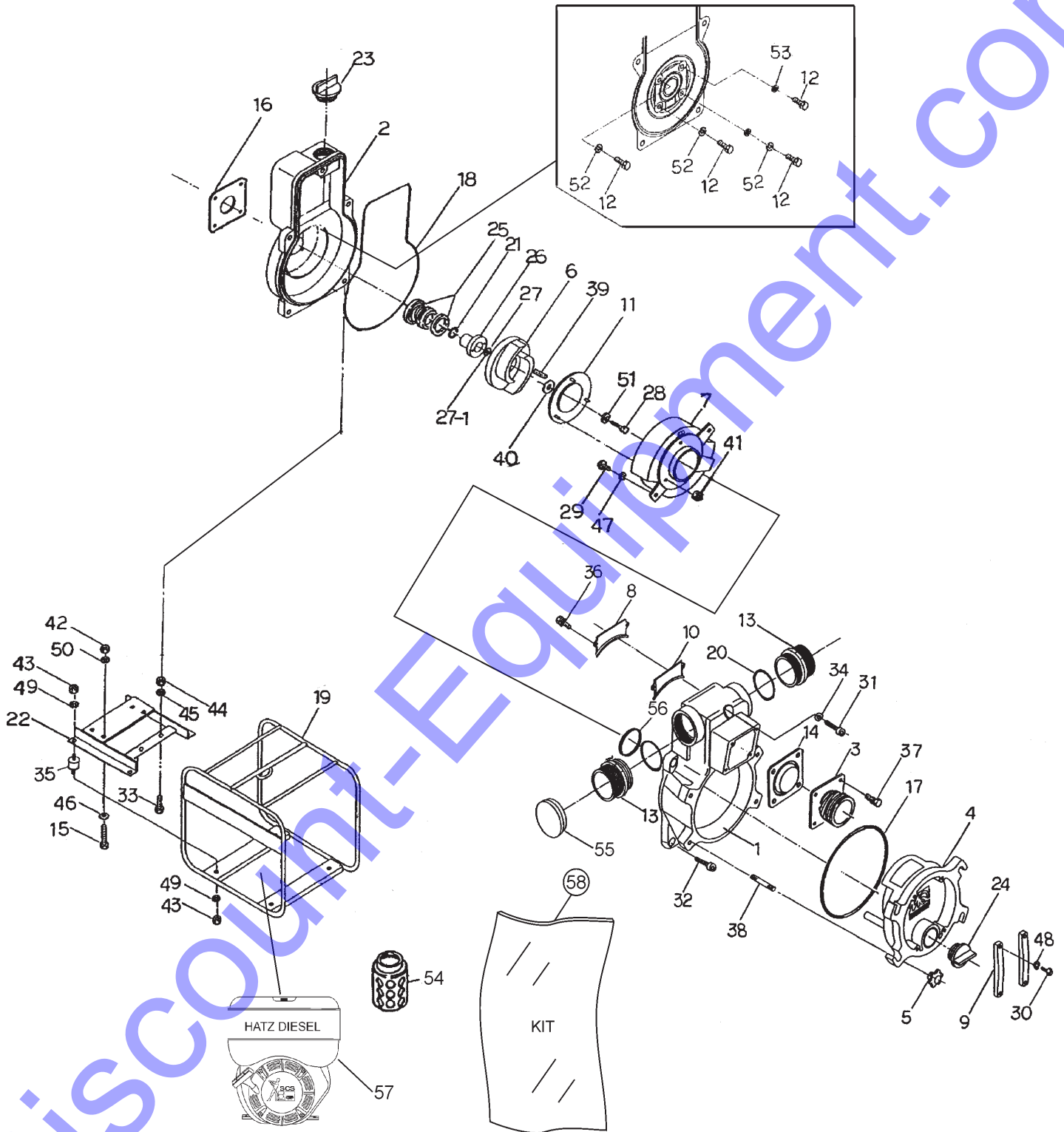

PUMP ASSY.

<u>NO.</u>	<u>PART NO.</u>	<u>PART NAME</u>	<u>QTY.</u>	<u>REMARKS</u>
38	0151191250	STUD BOLT (DRAIN COVER HANDLE), M12 X 50 X15 X 20	4	
39	0520030413	KEY, 4.7 X 16	1	
40	43592012400011	IMPELLER WASHER, 35 X 9 T4.5	1	
41	0204490060	U-NUT (WEAR PLATE, M6	3	
42	0205490080	NUT, ENGINE, M8	4	
43	0205490100	NUT, CUSHION RUBBER, M10	8	
44	0205490100	NUT, PUMP, M10	2	
45	0451290100	SPRING WASHER, PUMP, M10	2	
46	0401650080	WASHER, ENGINE, M8	4	
47	0457290080	SPRING WASHER (VOLUTE CASING), M8	2	
48	0451290080	SPRING WASHER (DRAIN COVER SET), M8	4	
49	0451290100	SPRING WASHER (CUSHION RUBBER), M10	8	
50	0451290080	SPRING WASHER (ENGINE), M8	4	
51	0451290080	SPRING WASHER (IMPELLER), M8	1	
52	0451290080	SPRING WASHER (CASING COVER), M8	3	
53	0458220080	SEAL WASHER (CASING COVER)	1	
54	0742214050	STRAINER	1	
55	1889068050	CAP	1	
56	0741310700	O'RING, G70	1	
57	1B20	ENGINE, HATZ	1	
58	KIT2T	KIT, MECHANICAL SEAL, SLEEVE, & O-RINGS ..	1	INCLUDES ITEMS W/*

HATZ 1B20 — SPARE PARTS KIT ASSY.

SPARE PARTS KITS ASSY.

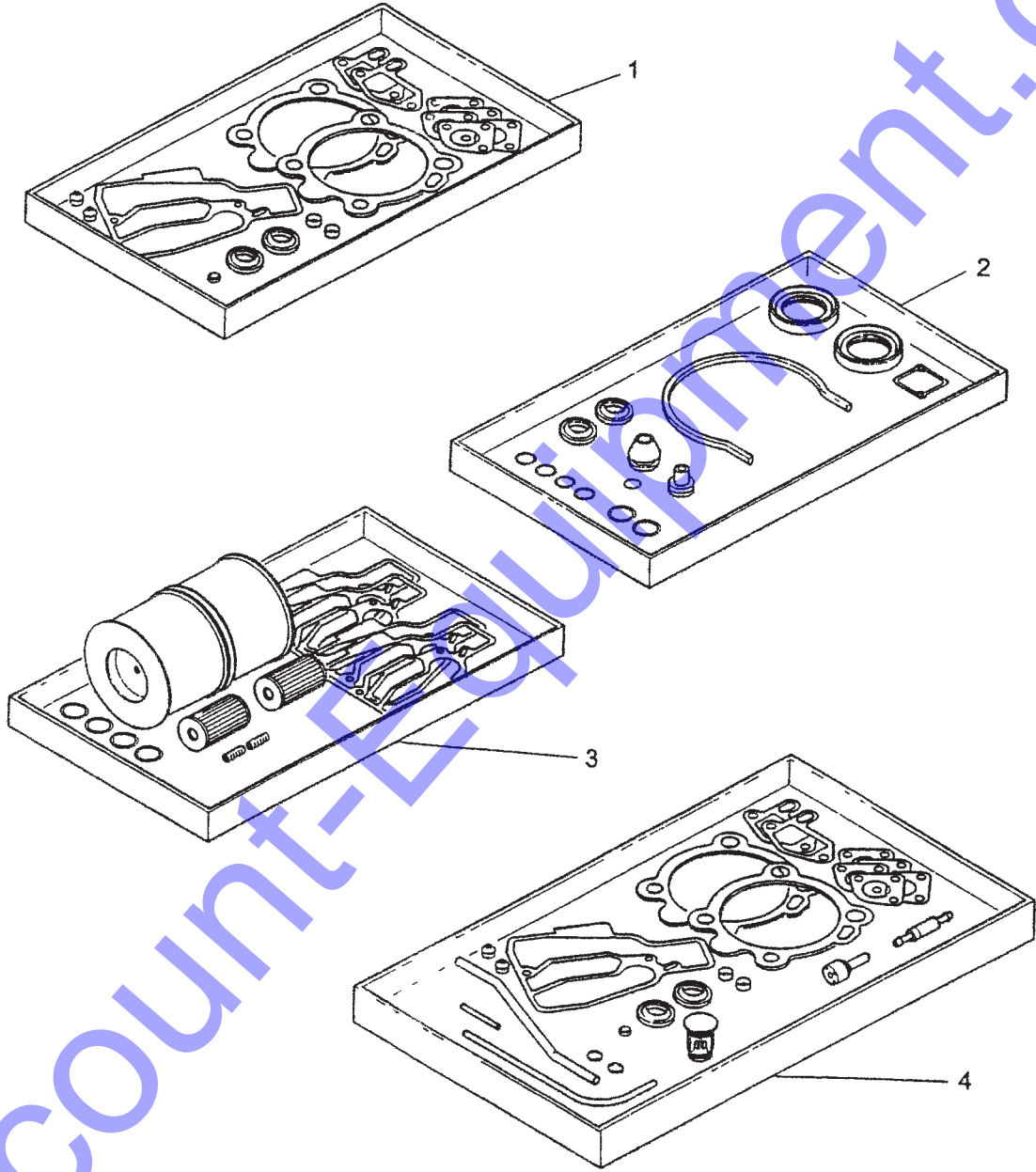

HATZ 1B20 — SPARE PARTS KIT ASSY.

SPARE PARTS KITS ASSY.

<u>NO.</u>	<u>PART NO.</u>	<u>PART NAME</u>	<u>QTY.</u>	<u>REMARKS</u>
1	01554100	GASKET SET CYL. HEAD	1	
2	01554200	GASKET SET CRANKCASE	1	
3	01554300	MAINTENANCE KIT- 1000 HRS	1	
4	01554400	EMERGENCY KIT	1	

HATZ 1B20 — ACCESSORIES ASSY.

ACCESSORIES ASSY.

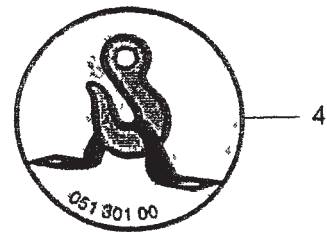
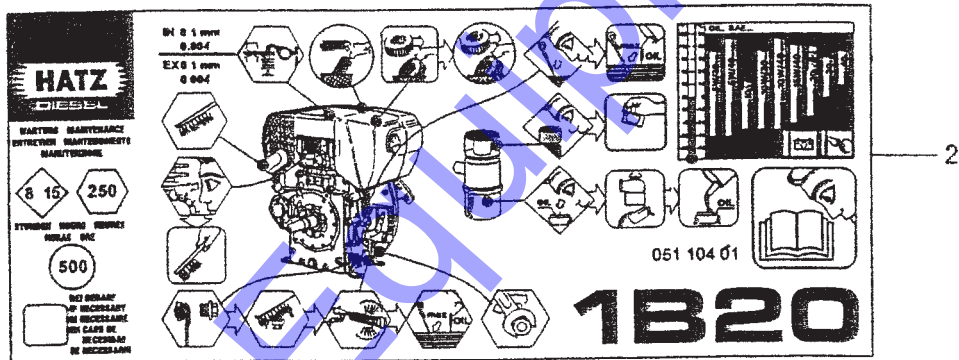
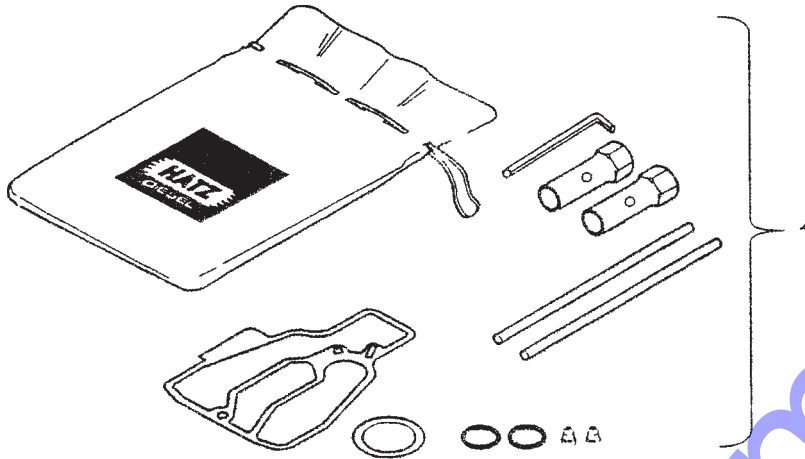

ACCESSORIES ASSY.

<u>NO.</u>	<u>PART NO.</u>	<u>PART NAME</u>	<u>QTY.</u>	<u>REMARKS</u>
1	01331001	TOOL KIT	1	
2	05110401	DECAL MAINTENANCE	1	
3	05130000	DECAL START	1	
4	05130100	DECAL	1	

HATZ 1B20 — CRANKCASE AND ENGINE MOUNT ASSY.

CRANKCASE AND ENGINE MOUNT ASSY.

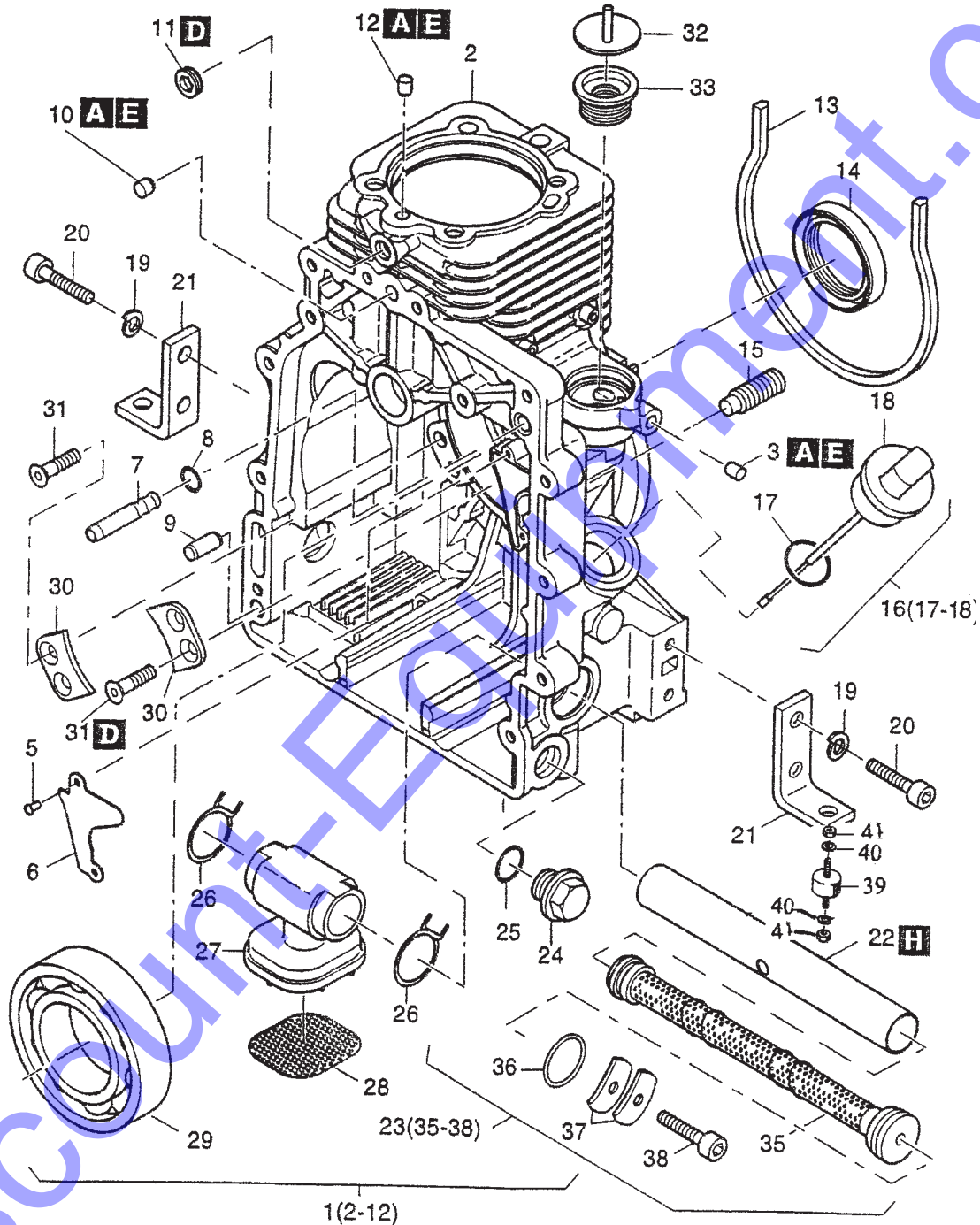

NOTE: Refer to Table 9 at the end of the manual for *letter* (A to L) call-outs.

HATZ 1B20 — CRANKCASE AND ENGINE MOUNT ASSY.

CRANKCASE AND ENGINE MOUNT ASSY.

<u>NO.</u>	<u>PART NO.</u>	<u>PART NAME</u>	<u>QTY.</u>	<u>REMARKS</u>
1	01552210	CRANKCASE ASSEMBLY	1	
2*		CRANKCASE	1	NOT SOLD SEPARATELY
3*	03455000	PLUG 6.5X7	1	
5*	40002600	BLIND RIVET	2	
6*	04105400	COVER PLATE	1	
7*	05084300	PIN	1	
8*	50440300	O- RING	1	INCLUDED IN CRANKC. GASK. SET
9*	50249101	CYL. PIN	1	
10*	04005500	PLUG	1	
11*	50062300	SCREW M10X1	1	
12*	04112800	PLUG	1	
13	04098000	SEALING STRIP 331.5 MM	1	INCLUDED IN CRANKC.GASK. SET
14	50423200	OIL SEAL 40X55X10	1	INCLUDED IN CRANKC. GASK. SET
15	04115200	GRUB SCREW	1	
16	01316000	DIPSTICK W/SEALING RING	1	INCLUDES ITEMS W/%
17%	04125000	SEALING RING	1	
18%		DIPSTICK.....	1	NOT SOLD SEPARATELY
19	50208500	SPRING WASHER	8	
20	04121900	ALL. SCREW M8X35	8	
21	04099302	ENGINE BRACKET	4	
22	04105710	TUBE F. OIL FILTER	1	
23	01542702	OIL SUCTION FILTER	1	INCLUDES ITEMS W/ #
24	50373100	DRAIN PLUG M22X1.5	1	INCLUDED IN MAINTENANCE KIT
25	50469800	JOINT A22X27	1	INCLUDED IN CRANKC. GASK. SET AND MAINTENANCE KIT
26	05036900	HOSE CLIP	2	
27	04104400	SUCTION PORT	1	
28	04104500	SIEVE	1	
29	50423300	BALL BEARING 6308	1	
30	04094400	PLATE	2	
31	50328000	CENTER SUNK SCREW AM6X16	4	
32	01555800	COVER	1	
33	03568700	RUBBER DIAPHRAGM	1	
35#		FILTER, OIL SUCTION	1	NOT SOLD SEPARATELY
36#	50475900	O- RING 20X4	1	
37#	05148200	PLATE SPRING	2	
38#	50170700	ALL. SCREW M6X16	1	
39	99400696	ISOLATOR	4	
40	50208500	SPRING WASHER	8	
41	50022900	NUT M8	8	

HATZ 1B20 — CRANKSHAFT ASSY.

CRANKSHAFT ASSY.

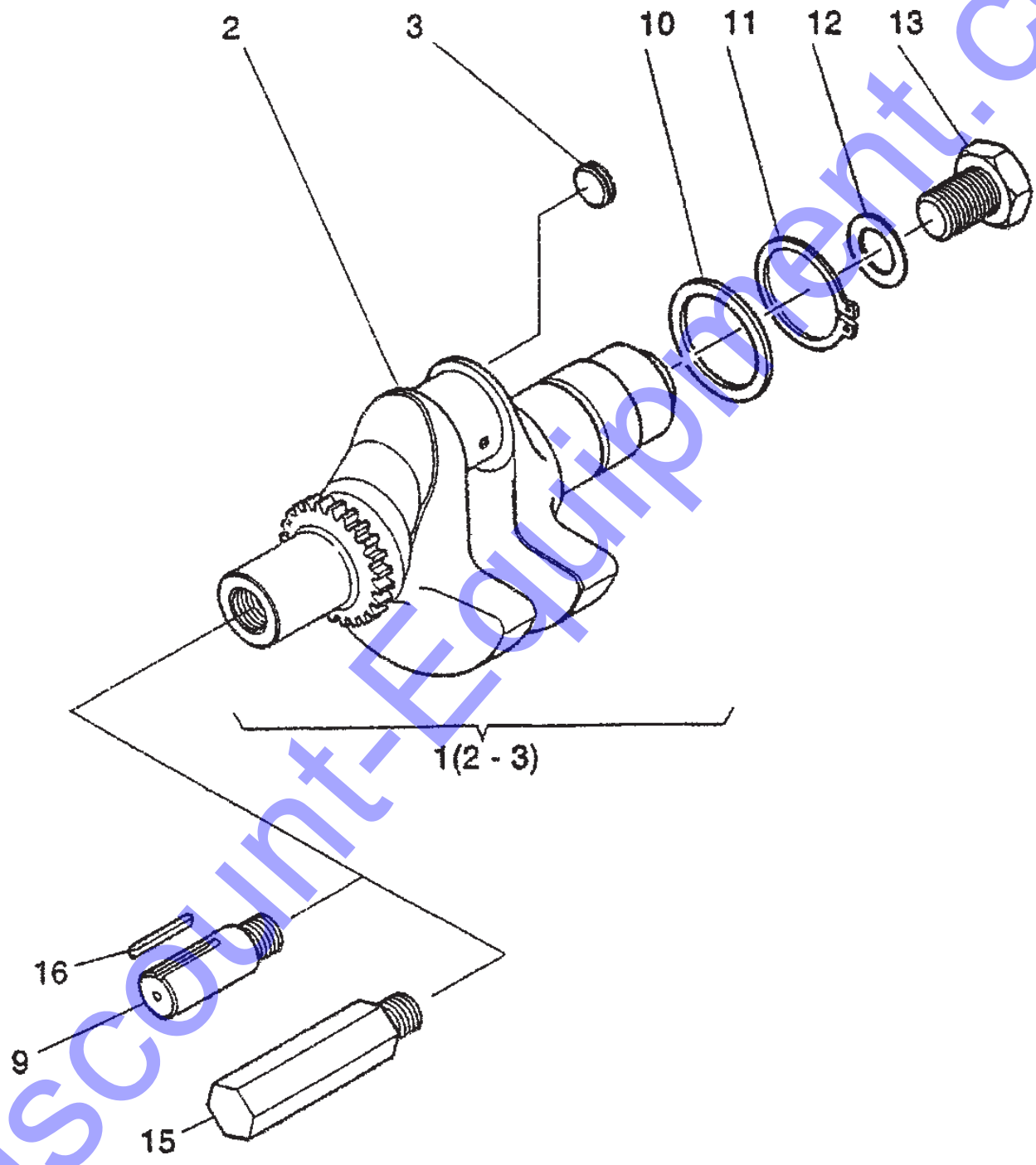

HATZ 1B20 — CRANKSHAFT ASSY.

CRANKSHAFT ASSY.

<u>NO.</u>	<u>PART NO.</u>	<u>PART NAME</u>	<u>QTY.</u>	<u>REMARKS</u>
1	01552700	CRANKSHAFT NO. X W/ PLUG	1	INCLUDES ITEMS W/*
2*		CRANKSHAFT	1	NOT SOLD SEPARATELY
3*	04125300	CLOSING PLUG 12 MM	1	
9	05100000	STUB SHAFT 20 DIA.	1	
10	40032500	SUPPORTING DISK 40X50X2.5	1	
11	50120600	CIRCLIP A40X1.75	1	
12	04114201	DISK 18.5X37X5	1	
13	50443600	HEX. SCREW M18X1.5X55	1	
15	05107301	STUB SHAFT SEM FINISHED 27 MM DIA.	1	
16	50463400	FITTING KEY A5X5X36	1	

HATZ 1B20 — CAMSHAFT ASSY.

CAMSHAFT ASSY.

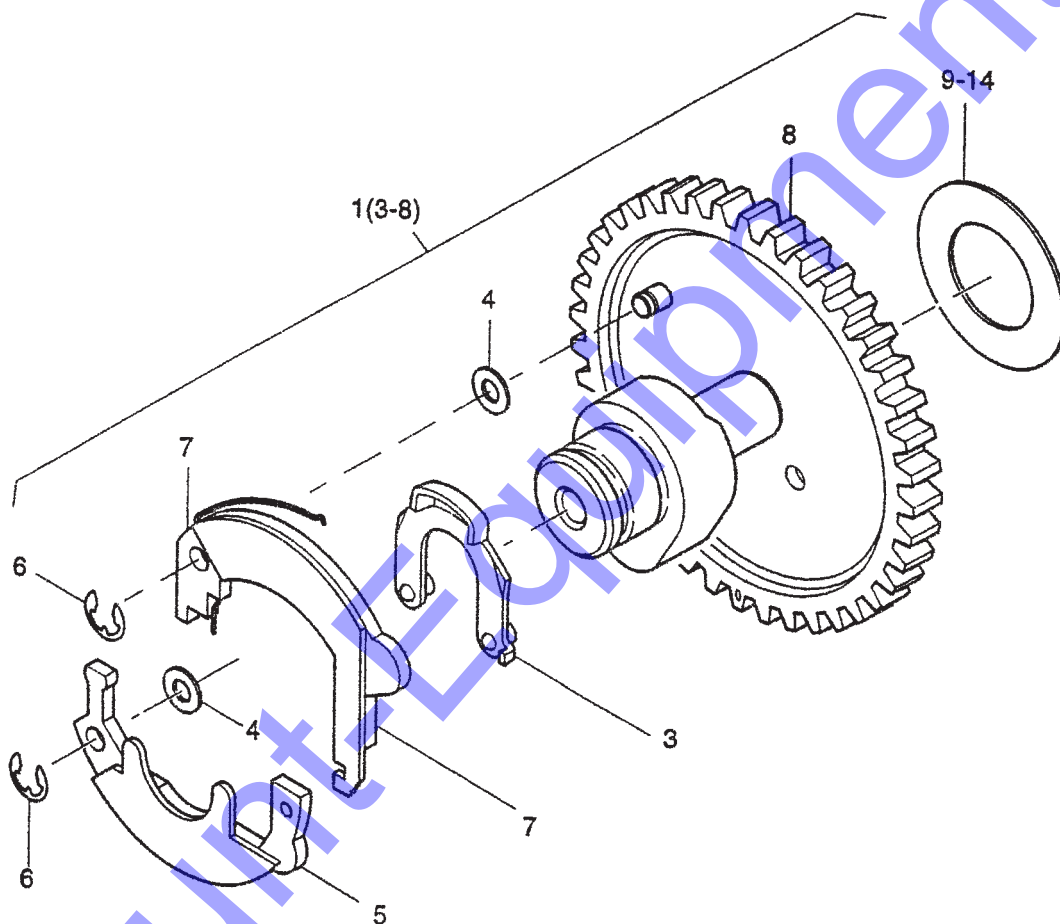

HATZ 1B20 — CAMSHAFT ASSY.

CAMSHAFT ASSY.

<u>NO.</u>	<u>PART NO.</u>	<u>PART NAME</u>	<u>QTY.</u>	<u>REMARKS</u>
1	01503520	CAMSHAFT ASSY.	1	INCLUDES ITEMS W/*
3*	01326400	CAMLEVER	1	
4*	50123200	SHIM 5X10X0.5 DIN988	2	
5*	01326600	FLYWEIGHT	1	
6*	50255300	LOCK WASHER	2	
7*	01326500	FLYWEIGHT	1	
8*		CAMSHAFT	1	NOT SOLD SEPARATELY
9	04121700	WASHER 0.9MM 23X38X0.9	1	
10	04112100	WASHER 1.0MM 23X38X1.0	1	
11	04112200	WASHER 1.1MM 23X38X1.1	1	
12	04112300	WASHER 1.2MM 23X38X1.2	1	
13	04125100	WASHER 1.3MM 23X38X1.3	1	
14	04125200	WASHER 1.4MM 23X38X1.4	1	

HATZ 1B20 — PISTON ASSY.

PISTON ASSY.

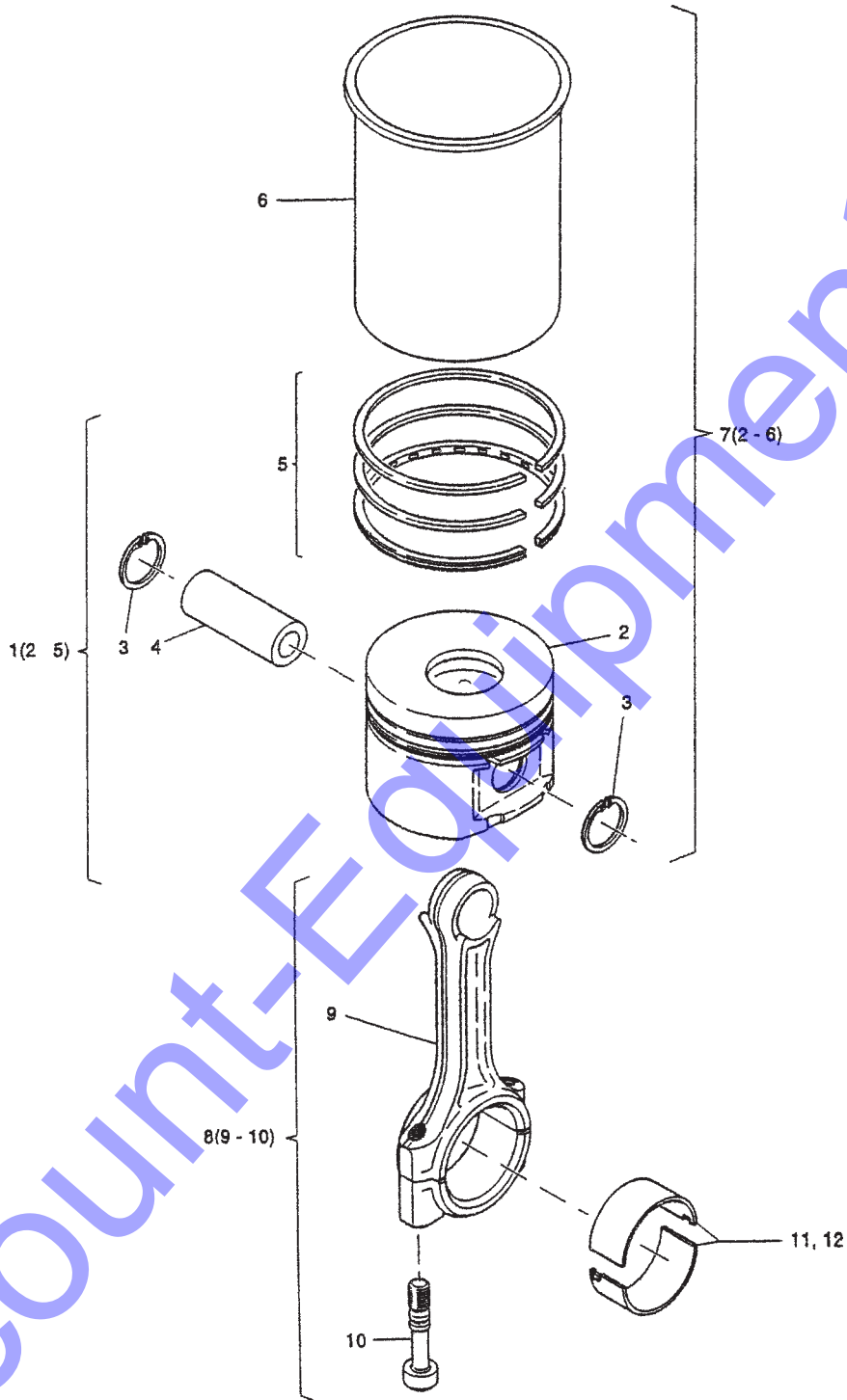

HATZ 1B20 — PISTON ASSY.

PISTON ASSY.

<u>NO.</u>	<u>PART NO.</u>	<u>PART NAME</u>	<u>QTY.</u>	<u>REMARKS</u>
1	01317100	PISTON 69MM ASSY.	1	INCLUDES ITEMS W/*
2*	%	PISTON 69MM	1	NOT SOLD SEPARATELY
3*	50425500	CIRCLIP	2	
4*	50425400	PISTON PIN	1	
5*	01317200	PISTON RING SET 69MM	1	
6%		CYLINDER	1	NOT SOLD SEPARATELY
7	01554500	CYLINDER WITH PISTON ASSY.	1	INCLUDES ITEMS W/%
8	01500100	CONROD ASSY.	1	INCLUDES ITEMS W/\$
9\$		CONROD	1	NOT SOLD SEPARATELY
10\$	05046900	CONROD SCREW	2	
11	01575700	BIG END BEARING	1	
12	01581900	BIG END BEARING - 0.5MM	1	

HATZ 1B20 — CYLINDER HEAD ASSY.

CYLINDER HEAD ASSY.

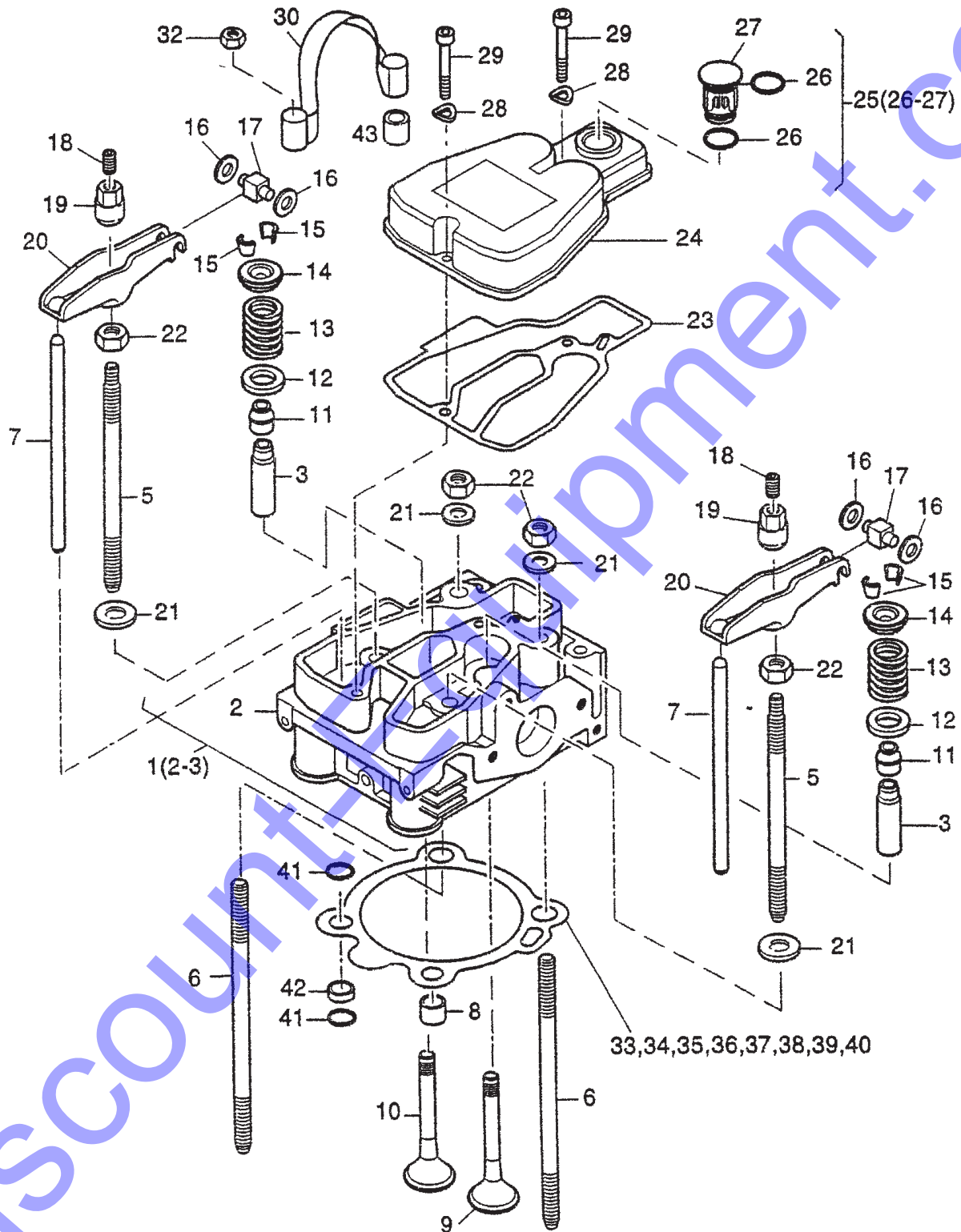

HATZ 1B20 — CYLINDER HEAD ASSY.

CYLINDER HEAD ASSY.

NO.	PART NO.	PART NAME	QTY.	REMARKS
1	01500221	CYLINDER HEAD ASSY	1	INCLUDES ITEMS W/*
2*		CYLINDER HEAD	1	NOT SOLD SEPARATELY
3*	05119400	VALVE GUIDE	2	
6	05062500	STUD CYLINDER HEAD 128MM	4	
7	05054000	PUSH ROD	2	
8	04107500	SEALING RING CYL. HEAD	2	INCLUDED IN CRANKC. GASK. SET
9	05053200	VALVE, INTAKE	1	
10	05053300	VALVE, EXHAUST	1	
11	50425800	VALVE STEM SEAL CAP	2	INCLUDED IN CRANKC. GASK. SET
12	04093700	WASHER	2	
13	04093600	VALVE SPRING	2	
14	04093800	SPRING PLATE	2	
15	50425700	COLLET	2	
16	50445100	DISK 6X12X1.2 DIN 988	4	
17	05091101	SLIDER	2	
18	50358000	GRUB SCREW M8X10	2	INCLUDED IN MAINTENANCE KIT
19	05054700	NUT FOR ROCKER ARM	2	
20	05050900	ROCKER	2	
21	05061201	WASHER 8.1X20X3	4	
22	50364300	HEX. NUT M8 DIN 934	4	
23	05055700	HEAD COVER GASKET	1	INCLUDED IN CRANKC. GASK. SET AND MAINTENANCE KIT
24	05047310	CYLINDER HEAD COVER	1	
25	01509600	DOSING DEVICE ASSY	1	INCLUDES ITEMS W/+ INCLUDED IN EMERGENCY KIT
26+	50425900	O- RING 16X2	2	
27+		DOSING DEVICE	1	NOT SOLD SEPARATELY
28	50081200	SPRING WASHER A6	2	
29	50374900	ALL SCREW M6X35	2	
30	04117600	LIFTING STRAP	1	
32	50129500	HEX. NUT M8	2	
33	05059400	CYLINDER HEAD GASKET 0.3MM	1	
34	05059500	CYLINDER HEAD GASKET 0.4MM	1	INCLUDED IN HEAD GASKET SET
35	05059600	CYLINDER HEAD GASKET 0.5MM	1	INCLUDED IN HEAD GASKET SET
36	05059700	CYLINDER HEAD GASKET 0.6MM	1	
37	05059800	CYLINDER HEAD GASKET 0.7MM	1	
38	05059900	CYLINDER HEAD GASKET 0.8MM	1	
39	05060000	CYLINDER HEAD GASKET 0.9MM	1	
40	05060100	CYLINDER HEAD GASKET 1.0MM	1	

HATZ 1B20 — OIL PUMP/GOVERNOR ASSY.

OIL PUMP/GOVERNOR

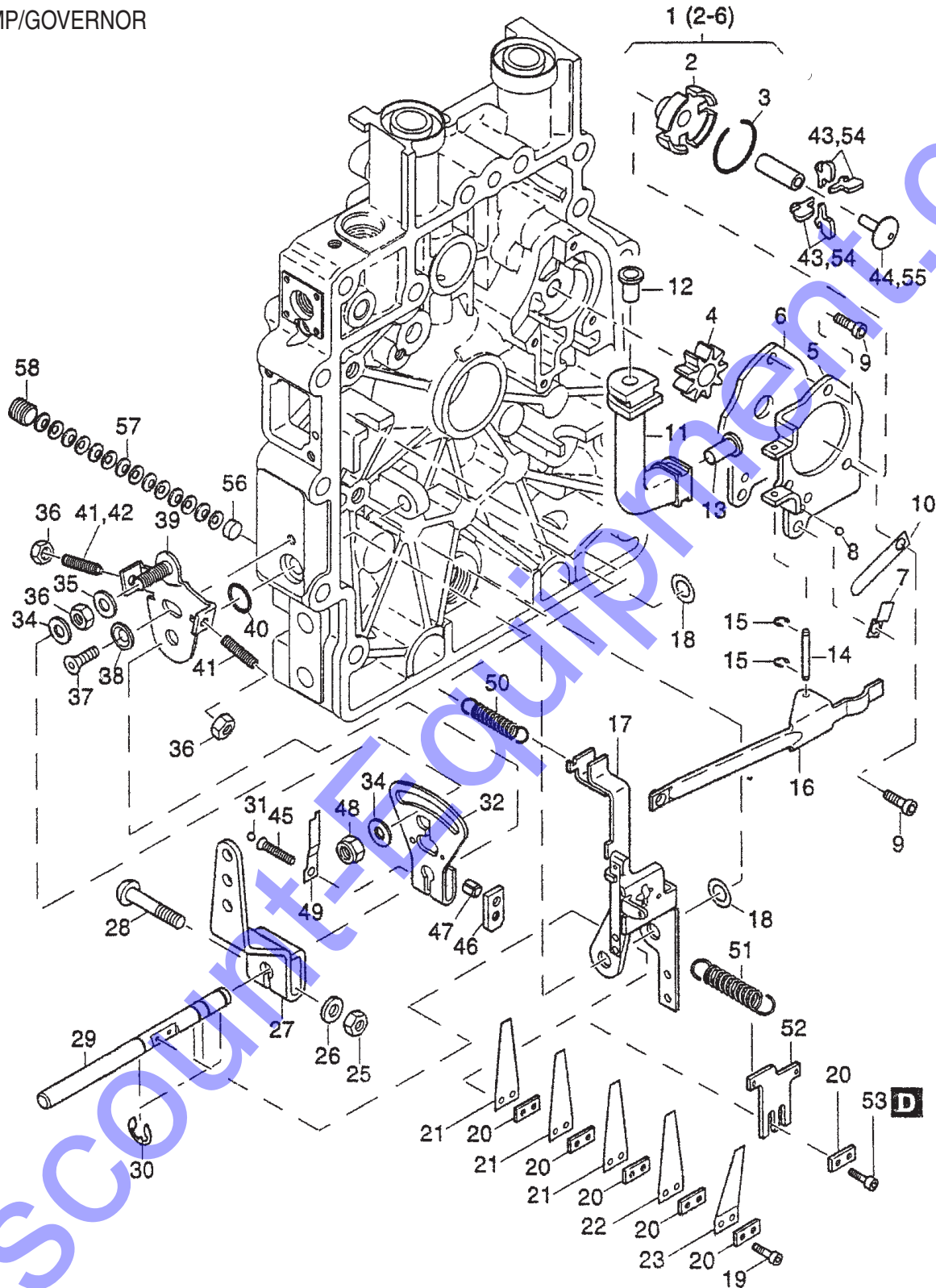

NOTE: Refer to Table 9 at the end of the manual for *letter* (A to L) call-outs.

HATZ 1B20 — OIL PUMP/GOVERNOR ASSY.

OIL PUMP/GOVERNOR

<u>NO.</u>	<u>PART NO.</u>	<u>PART NAME</u>	<u>QTY.</u>	<u>REMARKS</u>
1	01530210	COVER OIL PUMP ASSY.	1	INCLUDES ITEMS W/*
2*		COVER, OIL PUMP	1	NOT SOLD SEPARATELY
3*	50434901	CIRCLIP	1	
4*		GEAR, OIL PUMP	1	NOT SOLD SEPARATELY
5*		HOUSING, OIL PUMP	1	NOT SOLD SEPARATELY
6*		HOUSING, OIL PUMP	1	NOT SOLD SEPARATELY
7	05097100	RETAINING STRAP	1	
8	50447900	BALL 3.5MM	1	
9	50429400	ALL. SCREW M5X12	4	
10	05097300	FLAT SPRING 0.4	1	
11	04102900	OIL SUCTION TUBE	1	
12	50447400	TUBE INSERT	1	
13	50447500	TUBE INSERT	1	
14	05078600	SHAFT	1	
15	50434800	CIRCLIP	2	
16	05079400	LEVER	1	
17	01530402	GOVERNOR LEVER	1	
18	50422400	SHIM 8X14X1	2	
18	50125800	DISK 8X14X0.5	2	
19	50435000	ALL. SCREW M3X12	2	
20	05079800	INTERMED. PLATE	5	
21	05131600	GOVERNOR SPRING 0.2MM	3	
22	05078900	GOVERNOR SPRING 0.3	1	
23	05148600	STOP SPRING 0.4MM	1	
25	50144400	HEX. NUT M6	1	
26	50144500	FLAT WASHER	1	
27	04095600	LEVER	1	
28	03927300	SCREW M6X32	1	
29	05079301	SHAFT	1	
30	50092700	CIRCLIP	4	
31	50347100	BALL 3.175MM	1	
32	01333000	CONSOLE	1	
34	50114300	DISK	2	
35	50144500	FLAT WASHER	1	
36	50144400	HEX. NUT M6	3	
37	50423900	CTR. SUNK SCREW M6X20	1	
38	04122900	DISK	1	
39	01316402	SUPPORT	1	

HATZ 1B20 — OIL PUMP/GOVERNOR ASSY. (CONT.)

OIL PUMP/GOVERNOR

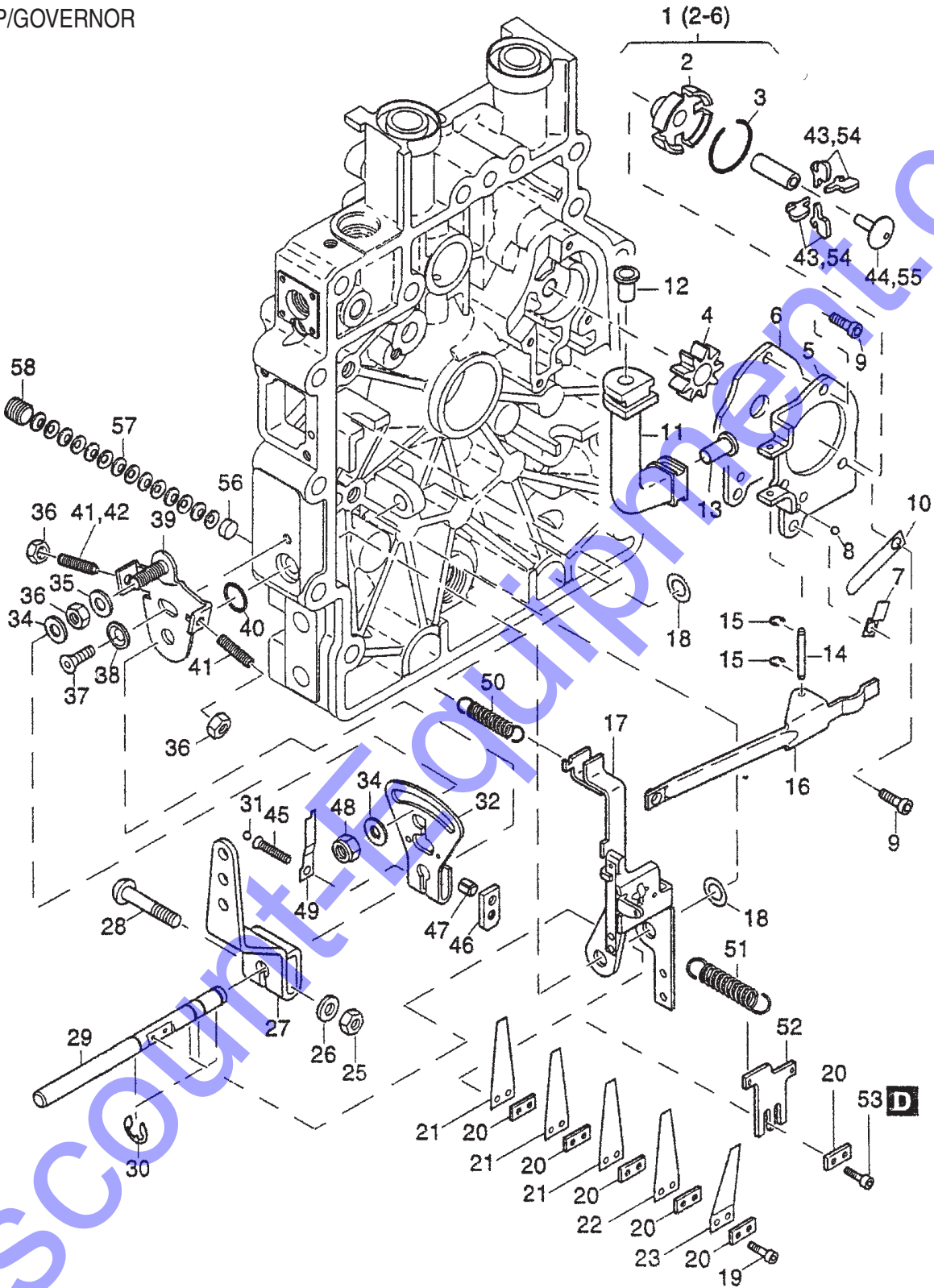

NOTE: Refer to Table 9 at the end of the manual for *letter* (A to L) call-outs.

HATZ 1B20 — OIL PUMP/GOVERNOR ASSY. (CONT.)

OIL PUMP/GOVERNOR

<u>NO.</u>	<u>PART NO.</u>	<u>PART NAME</u>	<u>QTY.</u>	<u>REMARKS</u>
40	40022401	O- RING 8X2	1	
41	50138100	THREADED PIN M6X35	2	
42	50004200	THREADED PIN M6X18	1	
43	05079601	CENTRIFUGAL WEIGHT	8	
44	05078501	GOVERNOR SLEEVE	1	
45	50475300	FILL. HEAD SCREW 5X25	1	
46	05151300	SUPPORT	1	
47	50475400	PIN 5X8	1	
48	50328300	HEX. NUT M6	1	
49	04122800	PLATE SPRING	1	
50	04000200	TENSION SPRING	1	
51	05130900	GOVERNOR SPRING	1	
52	05130800	STOP PLATE	1	
53	50465300	CYL. SCREW M3X8	2	
54	05146900	CENTRIFUGAL WEIGHT	4	
55	05147001	GOVERNOR SLEEVE	1	
56	05151700	PLUG	1	
57	50475800	PLATE SPRING	14	
58	50475700	GRUB SCREW M10X10	1	

HATZ 1B20 — TIMING COVER ASSY.

TIMING COVER ASSY.

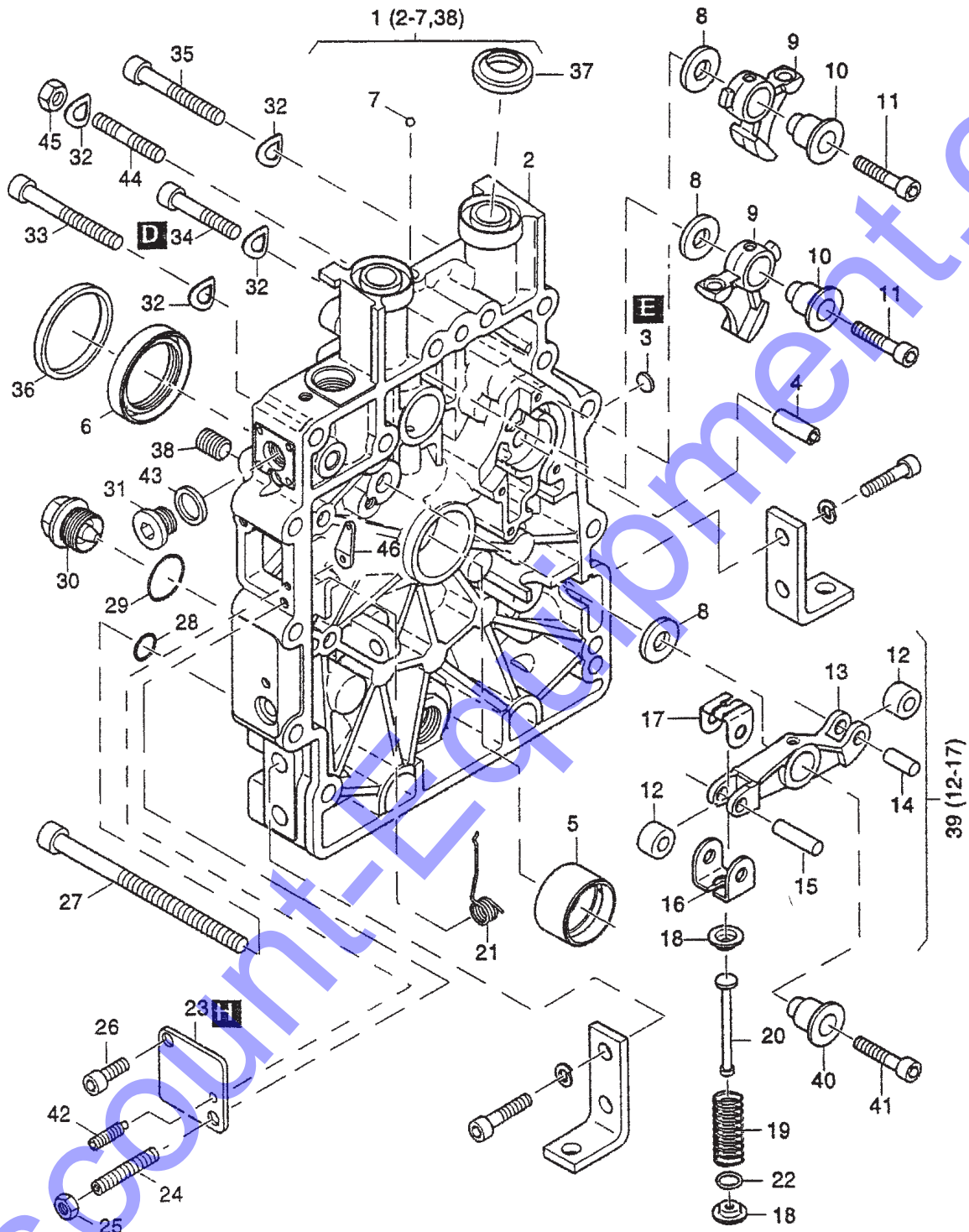

NOTE: Refer to Table 9 at the end of the manual for *letter* (A to L) call-outs.

HATZ 1B20 — TIMING COVER ASSY.

TIMING COVER ASSY.

<u>NO.</u>	<u>PART NO.</u>	<u>PART NAME</u>	<u>QTY.</u>	<u>REMARKS</u>
1	01319510	TIMING COVER ASSY	1	INCLUDES ITEMS W/*
2*		TIMING COVER	1	NOT SOLD SEPARATELY
3*	04130200	CLOSING PLUG	1	
4*	01533900	BOLT GOVERNOR HOUSING	1	
5*	05053100	MAIN BEARING	1	
5	04124800	MAIN BEARING - 0.5	1	
6*	40033700	OIL SEAL 30X47X8	1	IN CRANKCASE GASKET SET
7*	50443400	BALL	1	
8	03794100	WASHER	3	
9	05053400	CAM FOLLOWER	2	
10	03794201	CAM FOLLOW SPINDLE	2	
11	50457900	ALL. SCREW M6X25	2	
12\$		BUSHING, ROCKER ARM	2	NOT SOLD SEPARATELY
13\$		ROCKER ARM	1	NOT SOLD SEPARATELY
14\$		PIN, ROCKER ARM	1	NOT SOLD SEPARATELY
15\$		PIN, ROCKER ARM	1	NOT SOLD SEPARATELY
16\$		CLAMP, ROCKER ARM	1	NOT SOLD SEPARATELY
17\$		CLAMP, ROCKER ARM	1	NOT SOLD SEPARATELY
18	04094801	CUP	2	
19	04095700	PRESSURE SPRING	1	
20	04094700	DRAW ROD	1	
21	05095210	SPRING	1	
22	04133900	DISK 10.7X19X0.5	1	
23	04095210	COVER	1	
24	50448901	GRUB SCREW M6X30	1	
25	50144400	HEX. NUT M6	1	
26	50384200	ALL. SCREW M6X12	1	
27	50426100	ALL. SCREW M8X120	2	
28	50162900	JOINT A8X14	2	IN CRANKCASE GASKET SET
29	50469800	JOINT A22X27	1	IN MAINT. + CRANKCASE SET
30	50373100	DRAIN PLUG M22X1.5	1	IN MAINTENANCE KIT
31	50459200	CLOSING SCREW M12X1.5	1	
32	50095100	SPRING WASHER A8	13	
33	50248800	ALL. SCREW M8X60	1	
34	50453400	ALL. SCREW M8X45	2	
35	50392900	ALL. SCREW M8X50	9	
36	04097800	CENTERING RING SAE A	1	
37	04106500	SEALING RING TIMING COVER	2	IN HEAD GASKET SET
38*	50358000	GRUB SCREW M8X10	5	
39	01319601	ROCKER ARM	1	INCLUDES ITEMS W/\$
40	04096810	CAM FOLLOW SPINDLE	1	
41	50469900	ALL. SCREW M6X30	1	
42	50274901	GRUB SCREW M4X20	1	
43	04122000	JOINT	1	
44	50038700	STUD M8X50	1	
45	50148000	HEX. NUT M8	1	
46	05127100	LEVER	1	

HATZ 1B20 — FLYWHEEL ASSY.

FLYWHEEL ASSY.

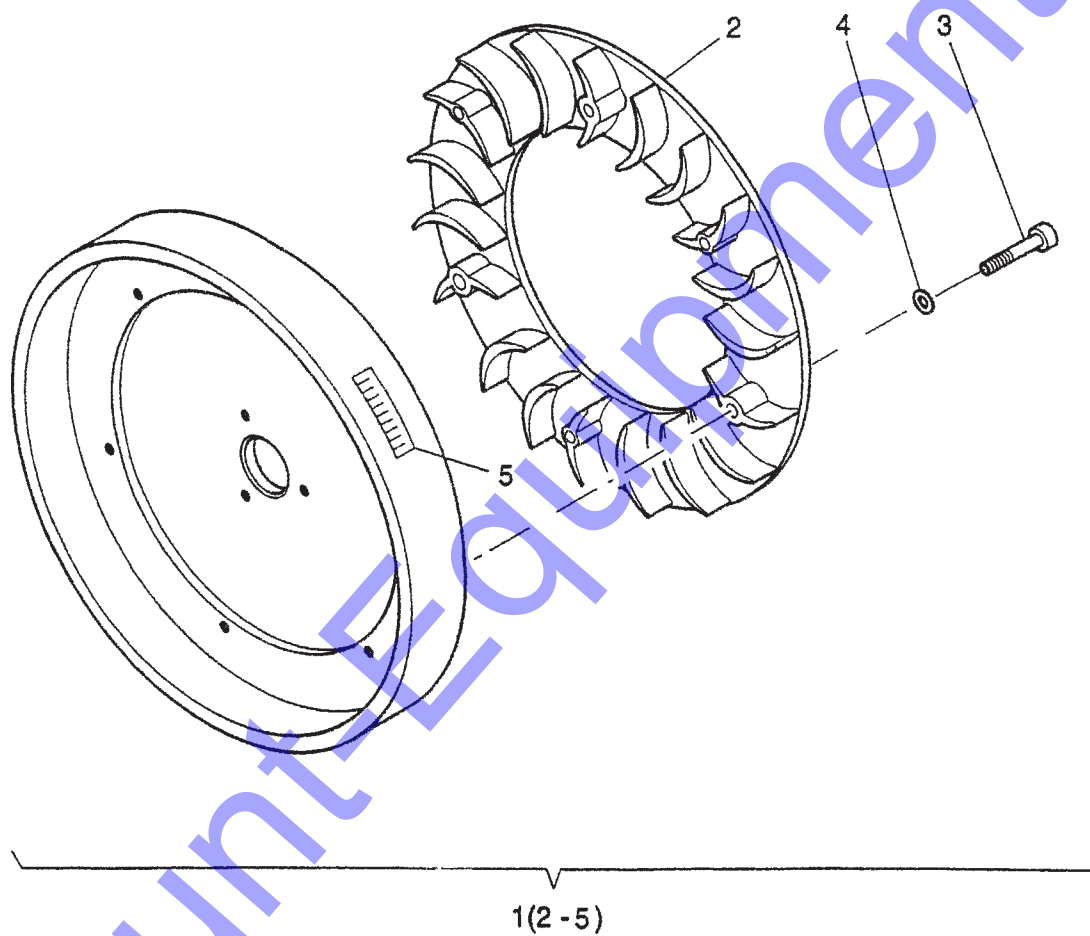

HATZ 1B20 — FLYWHEEL ASSY.

FLYWHEEL ASSY.

<u>NO.</u>	<u>PART NO.</u>	<u>PART NAME</u>	<u>QTY.</u>	<u>REMARKS</u>
1	01579710	FLYWHEEL W/ BLOWER	1	INCLUDES ITEMS W/ *
2*	01321310	BLOWER RING	1	
3*	50327300	ALL. SCREW M4X20	6	
4*	50003400	SPRING WASHER A4	6	
5*	04117300	STICKER "TDC"	1	

Discount-Equipment.com

HATZ 1B20 — FUEL INJECTION ASSY.

FUEL INJECTION ASSY.

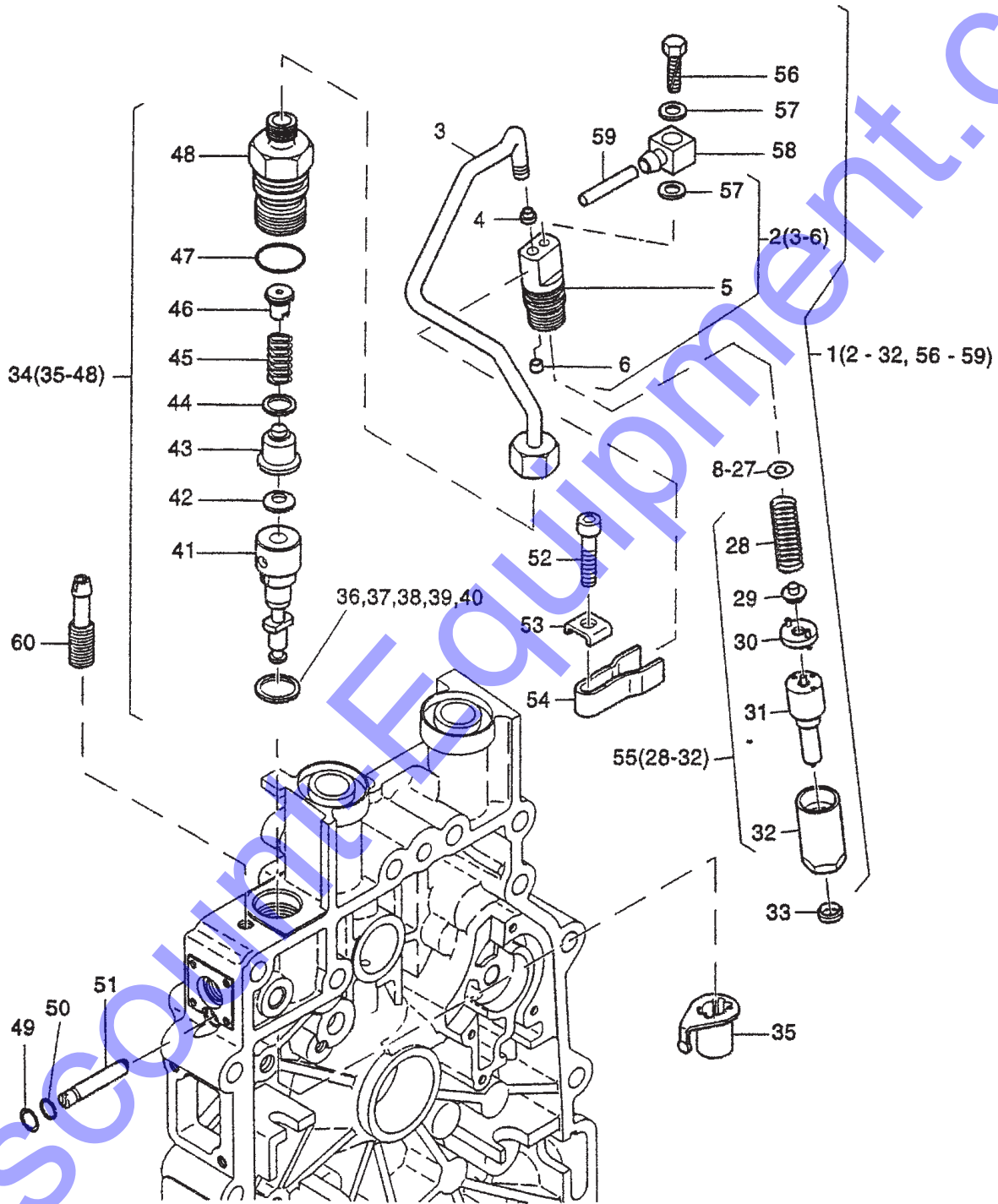

HATZ 1B20 — FUEL INJECTION ASSY.

FUEL INJECTION ASSY.

<u>NO.</u>	<u>PART NO.</u>	<u>PART NAME</u>	<u>QTY.</u>	<u>REMARKS</u>
1	01621600	INJECTOR ASSY.....	1	INCLUDES ITEMS W/\$
2\$	01577110	NOZZLE HOLDER ASSY	1	INCLUDES ITEMS W/#
3#\$		PIPE	1	NOT SOLD SEPARATELY
4#\$	05096101	SEALING CONE 4.9MM	1	SEE TECHNICAL ADVICE 95125801
4	05070601	SEALING CONE 5.3MM	1	
5#\$		NIPPLE BODY	1	NOT SOLD SEPARATELY
6#\$	05081500	SEALING CONE	1	
8\$	50436400	SHIM 1.00MM	1	
9\$	50436500	SHIM 1.04MM	1	
10\$	50436600	SHIM 1.10MM	1	
11\$	50436700	SHIM 1.14MM	1	
12\$	50436800	SHIM 1.20MM	1	
13\$	50436900	SHIM 1.24MM	1	
14\$	50437000	SHIM 1.30MM	1	
15\$	50437100	SHIM 1.34MM	1	
16\$	50437200	SHIM 1.40MM	1	
17\$	50437300	SHIM 1.44MM	1	
18\$	50437400	SHIM 1.50MM	1	
19\$	50437500	SHIM 1.54MM	1	
20\$	50437600	SHIM 1.60MM	1	
21\$	50437700	SHIM 1.64MM	1	
22\$	50437800	SHIM 1.70MM	1	
23\$	50437900	SHIM 1.74MM	1	
24\$	50438000	SHIM 1.80MM	1	
25\$	50438100	SHIM 1.84MM	1	
26\$	50438200	SHIM 1.90MM	1	
27\$	50438300	SHIM 1.94MM	1	
28+\$		SPRING	1	NOT SOLD SEPARATELY
29+\$		SPRING WASHER	1	NOT SOLD SEPARATELY
30+\$		PLATE	1	NOT SOLD SEPARATELY
31+\$	50442200	NOZZLE	1	IN EMERGENCY KIT
32+		BODY	1	NOT SOLD SEPARATELY
33	05070500	JOINT	1	IN HEAD GASKET SET

HATZ 1B20 — FUEL INJECTION ASSY. (CONT.)

FUEL INJECTION ASSY.

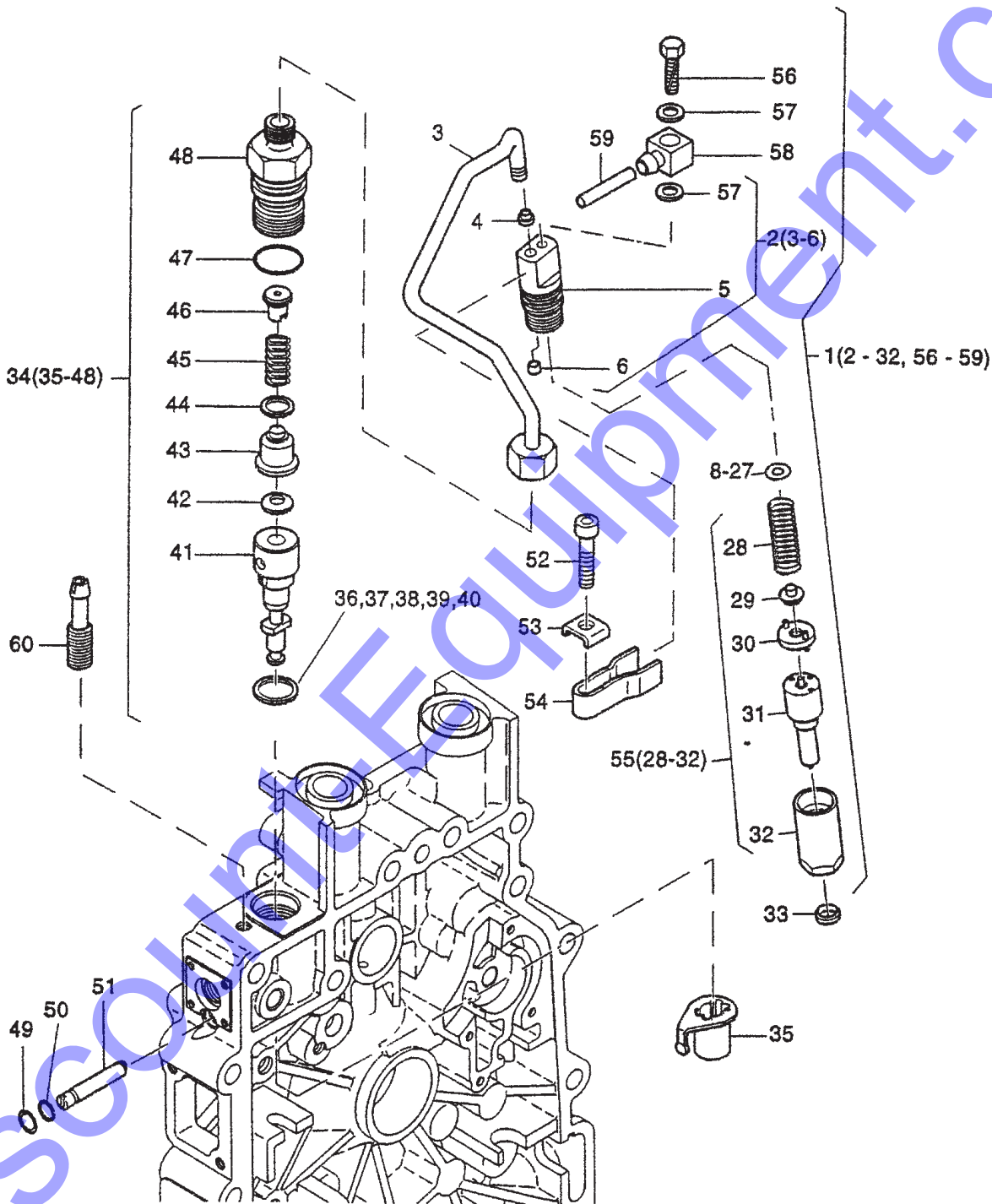

HATZ 1B20 — FUEL INJECTION ASSY. (CONT.)

FUEL INJECTION ASSY.

NO.	PART NO.	PART NAME	QTY.	REMARKS
34	01322200	INJECTION PUMP	1	INCLUDES ITEMS W/*
35*	01330800	CONTROL SLEEVE	1	
36*	04096300	SHIM 0.2MM	1	
37*	04096400	SHIM 0.3MM	1	
38*	04096500	SHIM 0.4MM	1	
39*	04096600	SHIM 0.5MM	1	
40*	04096700	SHIM 0.6MM	1	
41*		VALVE, FUEL INJECTOR PUMP	1	NOT SOLD SEPARATELY
42*	50471600	SPRING WASHER 8	1	
43*		BODY, FUEL INJECTOR PUMP	1	NOT SOLD SEPARATELY
44*	50476900	WASHER	1	
45*		SPRING, FUEL	1	NOT SOLD SEPARATELY
46*		BODY, FUEL	1	NOT SOLD SEPARATELY
47*	50476500	O- RING 17X2	1	
48*	50445900	VALVE HOLDER	1	
49	50476000	DISC 8	1	
50	50433900	O- RING 1.0X3.3	1	
51	04097700	PIN	1	
52	50323900	ALL. SCREW M6X30	1	
53	05089300	RETAINING YOKE	1	
54	05056700	FORK FOR INJECTOR	1	
55	01326100	PARTS SET NOZZLE ASSY.	1	INCLUDES ITEMS W/+
56\$	50464500	HEX SCREW M6X16	1	
57\$	50110800	JOINT A4X8	2	
58\$	05129000	CONNECTING NIPPLE	1	
59\$	05130200	HOSE 2.5X285	1	
60	05084201	CONNECTING NIPPLE	1	

HATZ 1B20 — RECOIL STARTER ASSY.

RECOIL STARTER ASSY.

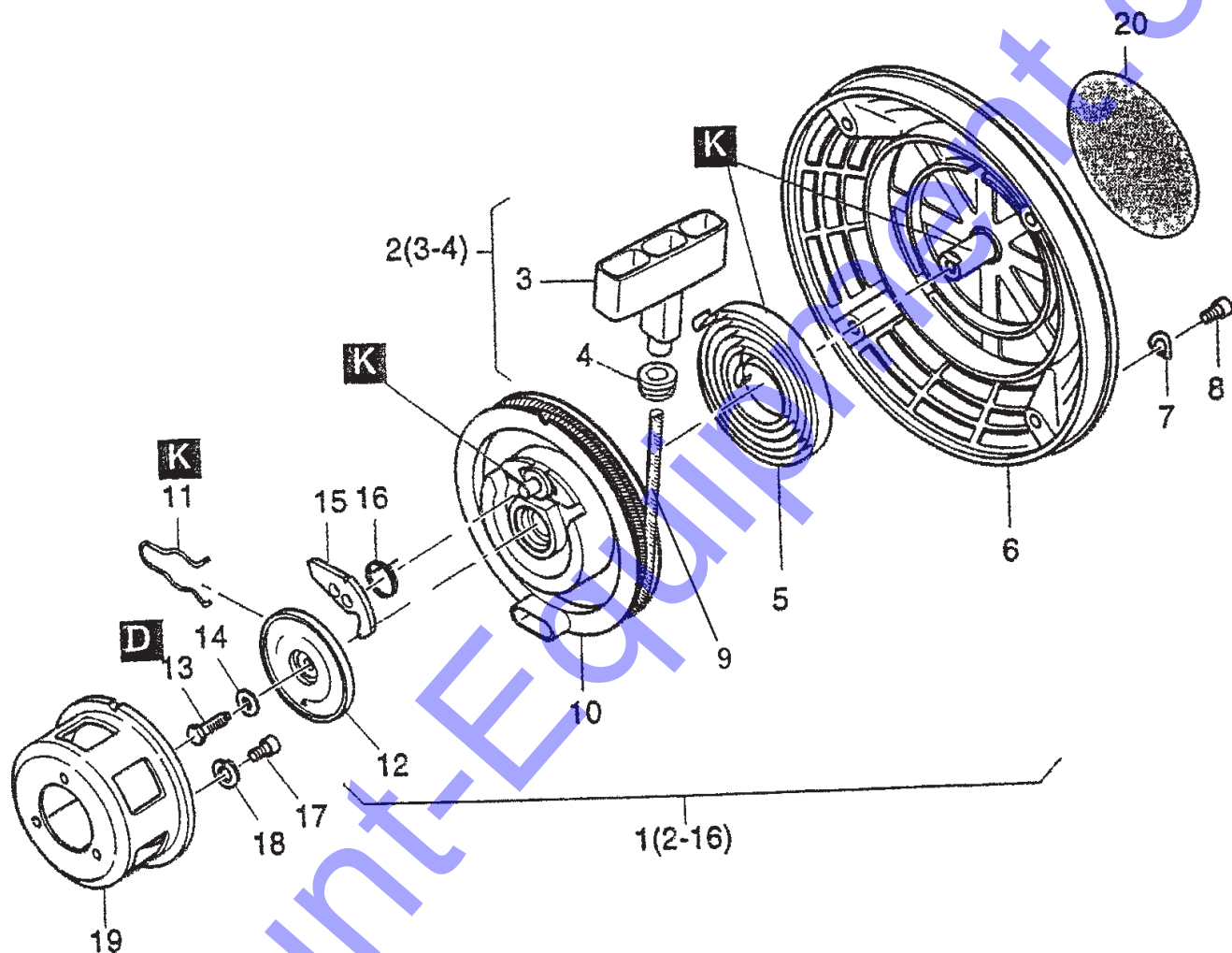

NOTE: Refer to Table 9 at the end of the manual for *letter* (A to L) call-outs.

HATZ 1B20 — RECOIL STARTER ASSY.

RECOIL STARTER ASSY.

<u>NO.</u>	<u>PART NO.</u>	<u>PART NAME</u>	<u>QTY.</u>	<u>REMARKS</u>
1	01515002	RECOIL STARTER ASSY.	1	INCLUDES ITEMS W/*
2*	01497800	HANDLE ASSY.	1	INCLUDES ITEMS W/#
3*#		HANDLE	1	NOT SOLD SEPARATELY
4*#	03665200	RUBBER SLEEVE	1	
5*	05045201	RETURN SPRING	1	
6*	01569300	HOUSING RECOIL STARTER	1	
7*	50081200	SPRING WASHER A6	4	
8*	50062700	ALLEN SCREW M6X10	4	
9*	05088901	ROPE RECOIL STARTER	1	
10*	01548800	ROPE PULLEY	1	
11*	05044901	BRAKE SPRING	1	
12*	05045001	BRAKE DISK	1	
13*	50146300	HEX SCREW M6X18	1	
14*	50165600	SPRING WASHER	1	
15*	05044800	RATCHET	1	
16*	05061300	RETURN SPRING	1	
17	50062700	ALLEN SCREW M6X10	3	
18	50170900	SPRING WASHER 6	3	
19	50445800	DRIVING SLEEVE	1	
20	05109100	STICKER LABEL	1	

HATZ 1B20 — AIR DUCT ASSY.

AIR DUCT ASSY.

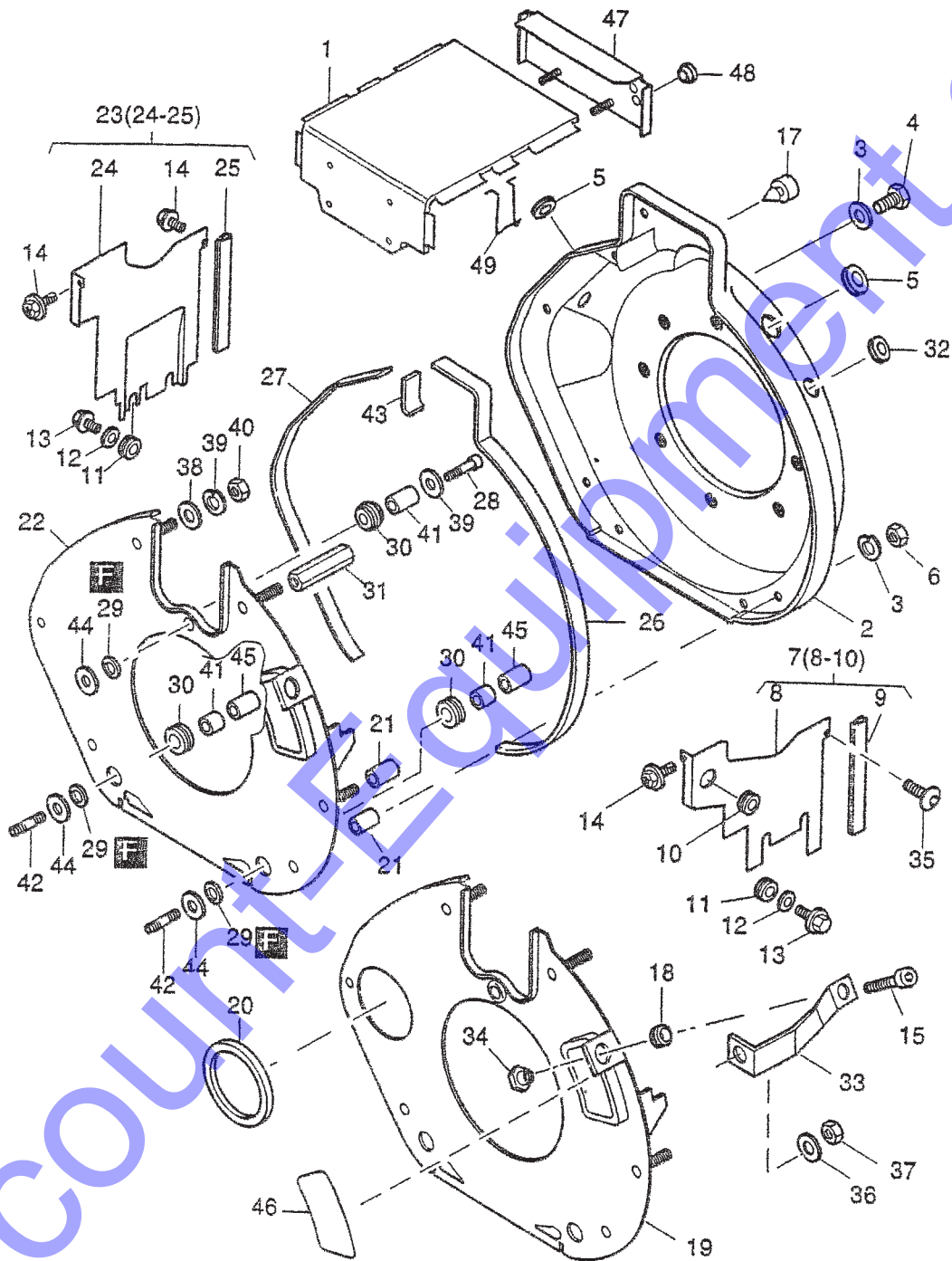

NOTE: Refer to Table 9 at the end of the manual for *letter* (A to L) call-outs.

HATZ 1B20 — AIR DUCT ASSY.

AIR DUCT ASSY.

<u>NO.</u>	<u>PART NO.</u>	<u>PART NAME</u>	<u>QTY.</u>	<u>REMARKS</u>
1	01533504	HOOD	1	
2	01316800	BLOWER DUCTING	1	
3	50170900	SPRING WASHER 6	7	
4	50146300	HEX SCREW M6X18	1	
5	50461700	RUBBER SLEEVE	2	
6	50144400	HEX NUT M6	6	
7	01316600	COOLING AIR DUCTING	1	INCLUDES ITEMS W/*
8*		AIR DUCT	1	NOT SOLD SEPARATELY
9*	04097600	SEALING STRIP 106.5 MM	1	
10*	50334800	RUBBER SLEEVE	1	
11	50163801	RUBBER SLEEVE	4	
12	50441600	WASHER 4,3	3	
13	50445400	HEX. SCREW M4X10	3	
14	50335600	COMBI SCREW M6X16	3	
15	50170700	ALLEN SCREW M6X16	1	
17	50392610	CAP	2	
18	50392800	RUBBER SLEEVE	1	
19	01607000	PARTING SHEET	1	ELECTRIC START ONLY
20	04099500	SEALING RING	1	
21	04139000	SPACER TUBE 6.5X12X18	5	
22	01607100	PARTING SHEET	1	
23	01316500	COOLING AIR DUCT	1	INCLUDES ITEMS W/#
24#		AIR DUCT	1	NOT SOLD SEPARATELY
25#	04097600	SEALING STRIP 106.5MM	1	
26	04124500	SEALING STRIP 470MM	1	
27	04124600	SEALING STRIP 388MM	1	

HATZ 1B20 — AIR DUCT ASSY. (CONT.)

AIR DUCT ASSY.

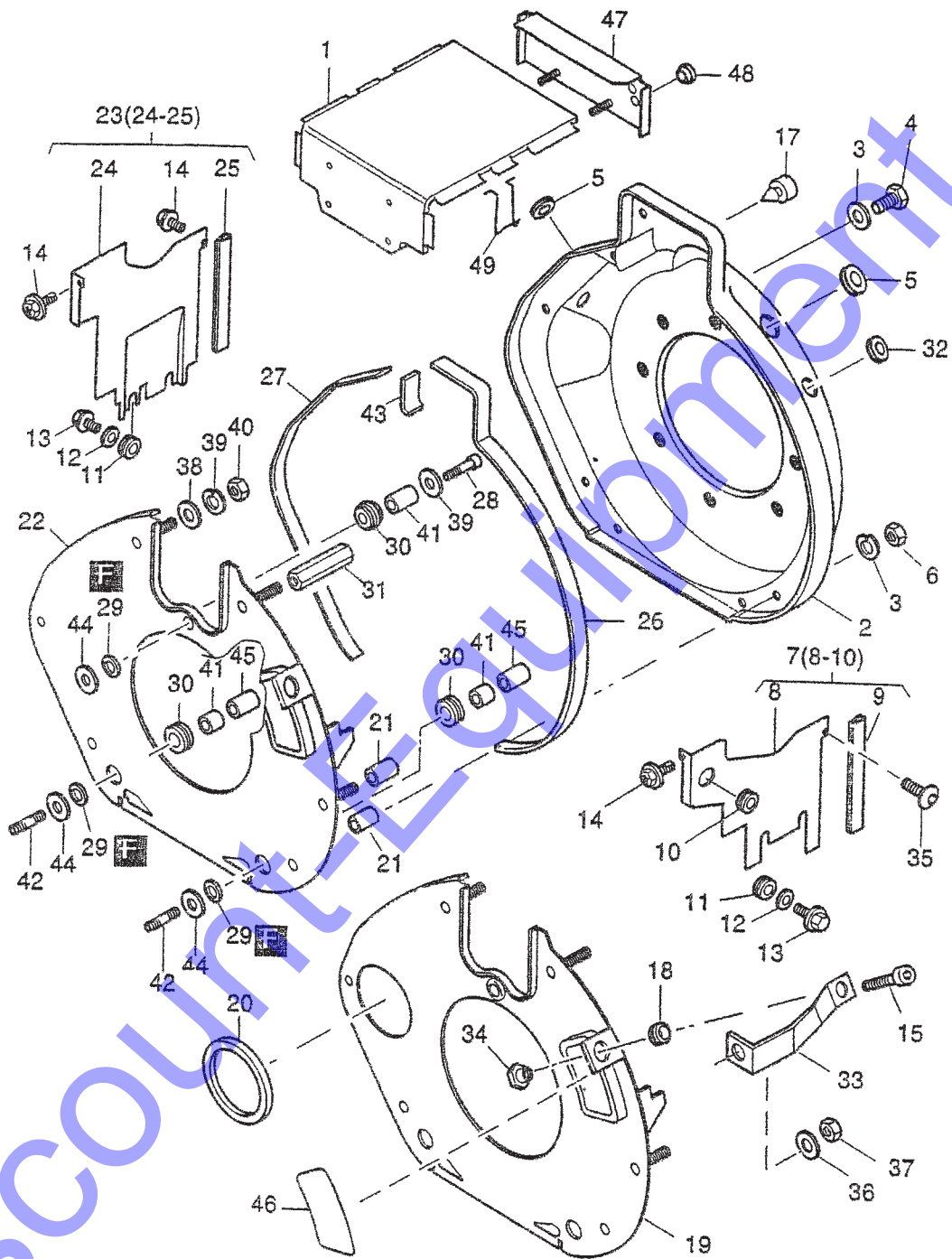

NOTE: Refer to Table 9 at the end of the manual for *letter* (A to L) call-outs.

HATZ 1B20 — AIR DUCT ASSY. (CONT.)

AIR DUCT ASSY.

<u>NO.</u>	<u>PART NO.</u>	<u>PART NAME</u>	<u>QTY.</u>	<u>REMARKS</u>
28	50170800	ALLEN SCREW M6X25	1	
29	03575500	SEALING RING	3	
30	00921400	SPACER BUSHING	3	
31	04124400	SPACER 57MM	1	
32	50453300	RUBBER SLEEVE	1	
33	01599500	SUPPORT	1	
34	04123200	THREAD, BUSH M6	1	
35	50328000	CTR. SUNK SCREW AM6X16	1	
36	50095100	SPRING WASHER A8	1	
37	50344700	HEX. NUT M8	1	
38	50144500	FLAT WASHER 6,4	2	
39	50170900	SPRING WASHER 6	3	
40	50144400	HEX. NUT M6	2	
41	04119100	CLAMP	3	
42	50458100	STUD M6X45	2	
43	05007300	SEALING STRIP 48MM	1	
44	04042000	WASHER 6.5X22.5X1	3	
45	04124300	BUSH 6.5X13X16.5	2	
46	04113800	COVER	1	
47	01579300	COVER	1	
48	50334800	RUBBER SLEEVE	2	
49	05144100	SPRING CLIP	1	

HATZ 1B20 — CRANKCASE BREATHER ASSY.

CRANKCASE BREATHER ASSY.

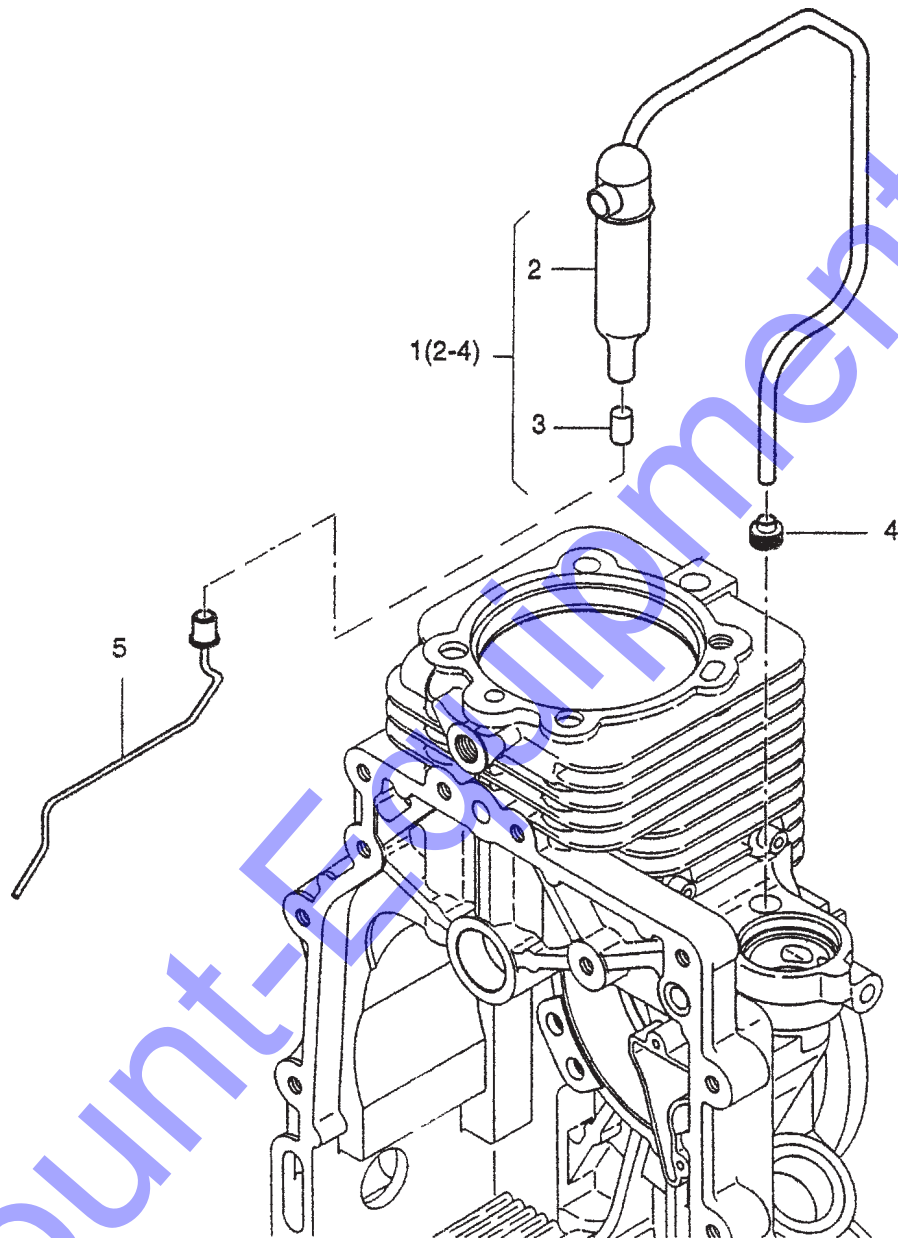

HATZ 1B20 — CRANKCASE BREATHER ASSY.

CRANKCASE BREATHER ASSY.

<u>NO.</u>	<u>PART NO.</u>	<u>PART NAME</u>	<u>QTY.</u>	<u>REMARKS</u>
1	01556400	OIL SEPARATOR ASSY.	1	INCLUDES ITEMS W/*
2*		OIL SEPARATOR	1	NOT SOLD SEPARATELY
3*	05102900	FILTER BREATHER SYSTEM	1	
4*	01583700	BREATHER TUBE	1	IN CRANKCASE GASKET SET
5	01551600	SUCTION PIPE	1	

HATZ 1B20 — FUEL TANK ASSY.

FUEL TANK ASSY.

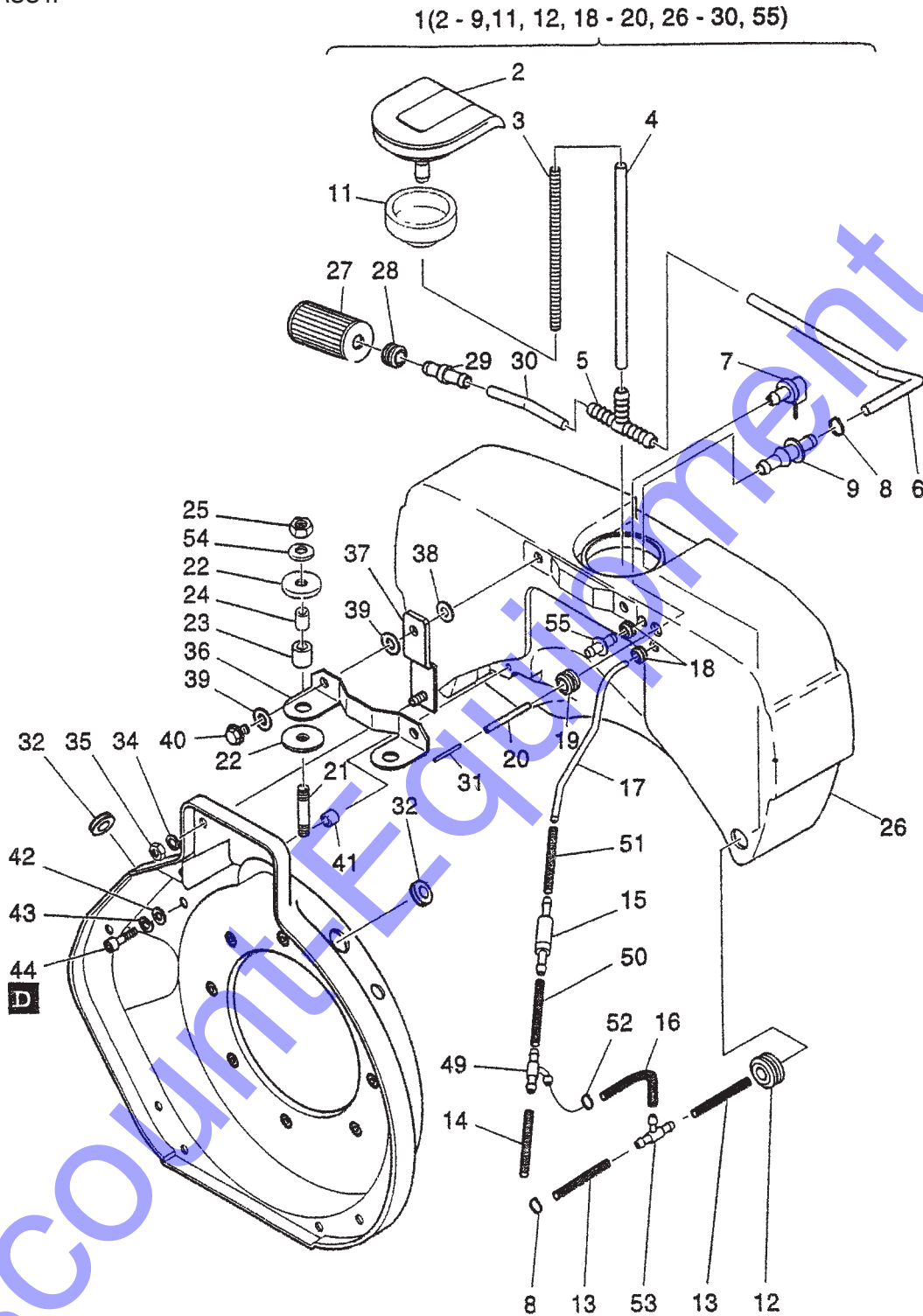

NOTE: Refer to Table 9 at the end of the manual for *letter* (A to L) call-outs.

HATZ 1B20 — FUEL TANK ASSY.

FUEL TANK ASSY.

<u>NO.</u>	<u>PART NO.</u>	<u>PART NAME</u>	<u>QTY.</u>	<u>REMARKS</u>
1	01578820	FUEL TANK ASSY 3 LITER	1	INCLUDES ITEMS W/*
2*	01535302	CAP FOR FUEL TANK	1	
3*	05084600	SPRING	1	
4*	05085100	FUEL HOSE 7X165	1	
5*	50440600	NIPPLE FOR FUEL TANK	1	
6*	05084900	FUEL HOSE 7X190	1	
7*	01534900	FUEL VENT VALVE	1	
8*	50441100	HOSE CLIP	2	IN EMERGENCY KIT
9*	05084000	CONNECTING NIPPLE	1	
11*	05086401	GASKET FOR FUEL CAP	1	
12*	50440800	RUBBER SLEEVE	1	
13	05123100	FUEL HOSE 7/70	2	
14	05085300	FUEL HOSE 3.5X45	1	
15	01534600	FUEL VENT VALVE	1	
16	03673300	FUEL HOSE 4.5/170	1	
17	05122200	FUEL PIPE	1	
18*	05130400	RUBBER SLEEVE	2	
19*	50440900	RUBBER SLEEVE	1	
20*	05085600	BREATHER HOSE	1	
21	50231900	STUD M8X25	2	
22	05109810	DISK 8.2X22X2	4	
23	05086810	RUBBER SHELL	2	
24	05122800	INSULATING SLEEVE	2	
25	40028400	HEX. NUT M8	2	
26*		FUEL TANK	1	NOT SOLD SEPARATELY
27*	01635200	FUEL FILTER	1	IN MAINTENANCE KIT INCLUDES ITEMS W/ #
28*#	50440900	RUBBER SLEEVE	1	
29*	05084400	CONNECTING NIPPLE	1	
30*	05085000	FUEL PIPE 7X70	1	
31	05085500	TUBE 1.4X2X16	1	
32	05107700	RUBBER SLEEVE	2	
34	50170900	SPRING WASHER 6	2	
35	50144400	HEX. NUT M6	2	
36	05108511	SUPPORT	1	
37	01331300	SUPPORT	2	
38	50120000	DISK A6,4	2	
39	05110010	DISK 7.1X17.9X2	4	
40	01557000	HEX. SCREW M6X16	2	
41	04118800	DISK 6.5X13X4.8	2	
42	50144500	FLAT WASHER 6,4	2	
43	50170900	SPRING WASHER 6	2	
44	50170700	ALL. SCREW M6X16	2	
49	05122700	HOSE NIPPLET	1	
50	05123200	FUEL HOSE 3.5X38	1	
51	03664300	FUEL HOSE 4.5X75	1	
52	50399801	CLAMP 11,3	1	
53	50459600	HOSE NIPPLE T	1	
54	50148100	FLAT WASHER 8,4	2	
55*	05129610	CONNECTING NIPPLE	1	

HATZ 1B20 — AIR FILTER ASSY.

AIR FILTER ASSY.

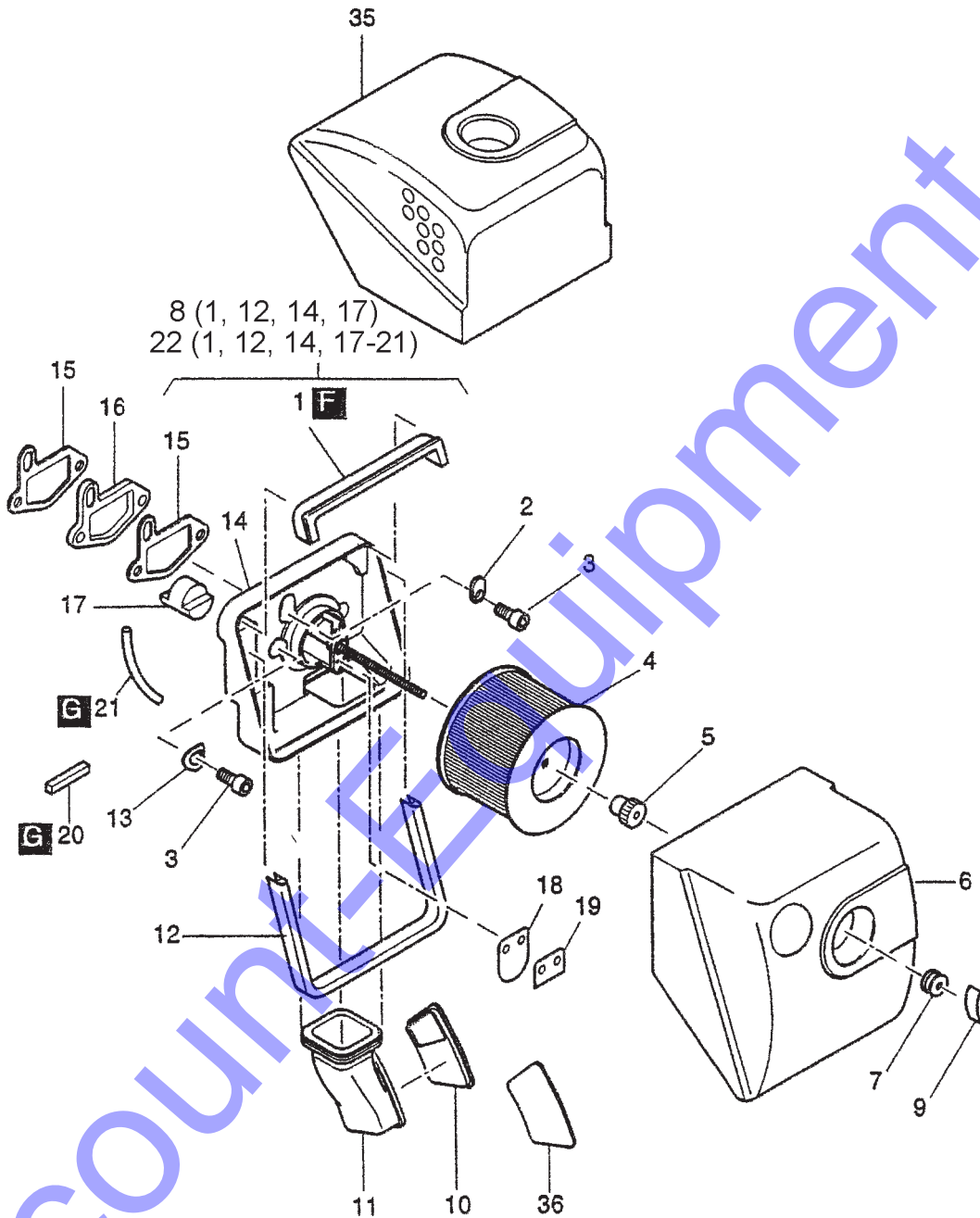

NOTE: Refer to Table 9 at the end of the manual for *letter* (A to L) call-outs.

HATZ 1B20 — AIR FILTER ASSY.

AIR FILTER ASSY.

<u>NO.</u>	<u>PART NO.</u>	<u>PART NAME</u>	<u>QTY.</u>	<u>REMARKS</u>
1*\$	\$05082900	SEALING STRIP	1	
2	05056400	WASHER	1	
3	50171500	ALL. SCREW M8X25	3	
4	50426000	AIR FILTER ELEMENT	1	IN MAINTENANCE KIT
5	50454300	NUT M6	1	
6	05054900	COVER AIR FILTER	1	
7	50435800	RUBBER SLEEVE	1	
8	01515100	AIR FILTER HOUSING ASSY	1	INCLUDES ITEMS W/*
9	50452200	WING NUT M6	1	
10	04104200	COVER, RUBBER INSERT	1	
11	04103000	RUBBER INSERT	1	
12*\$	05056100	SEALING STRIP 365MM	1	
13	50095100	SPRING WASHER A8	2	
14*\$		AIR FILTER ASSY	1	NOT SOLD SEPARATELY
15	05056300	GASKET AIR FILTER.....	2	IN HEAD GASKET SET
16	05088300	INSULATING FLANGE	1	
17*\$	05098100	PLUG	1	
18\$	05147100	VALVE PLATE	1	
19\$	05147200	VALVE PLATE	1	
20\$	03599000	SEALING STRIP 8X8X30	1	
21\$	05043810	HOSE 2X4X215	1	
22	01603600	AIR FILTER HOUSING	1	INCLUDES ITEMS W/ \$

HATZ 1B20 — MUFFLER ASSY.

MUFFLER ASSY.

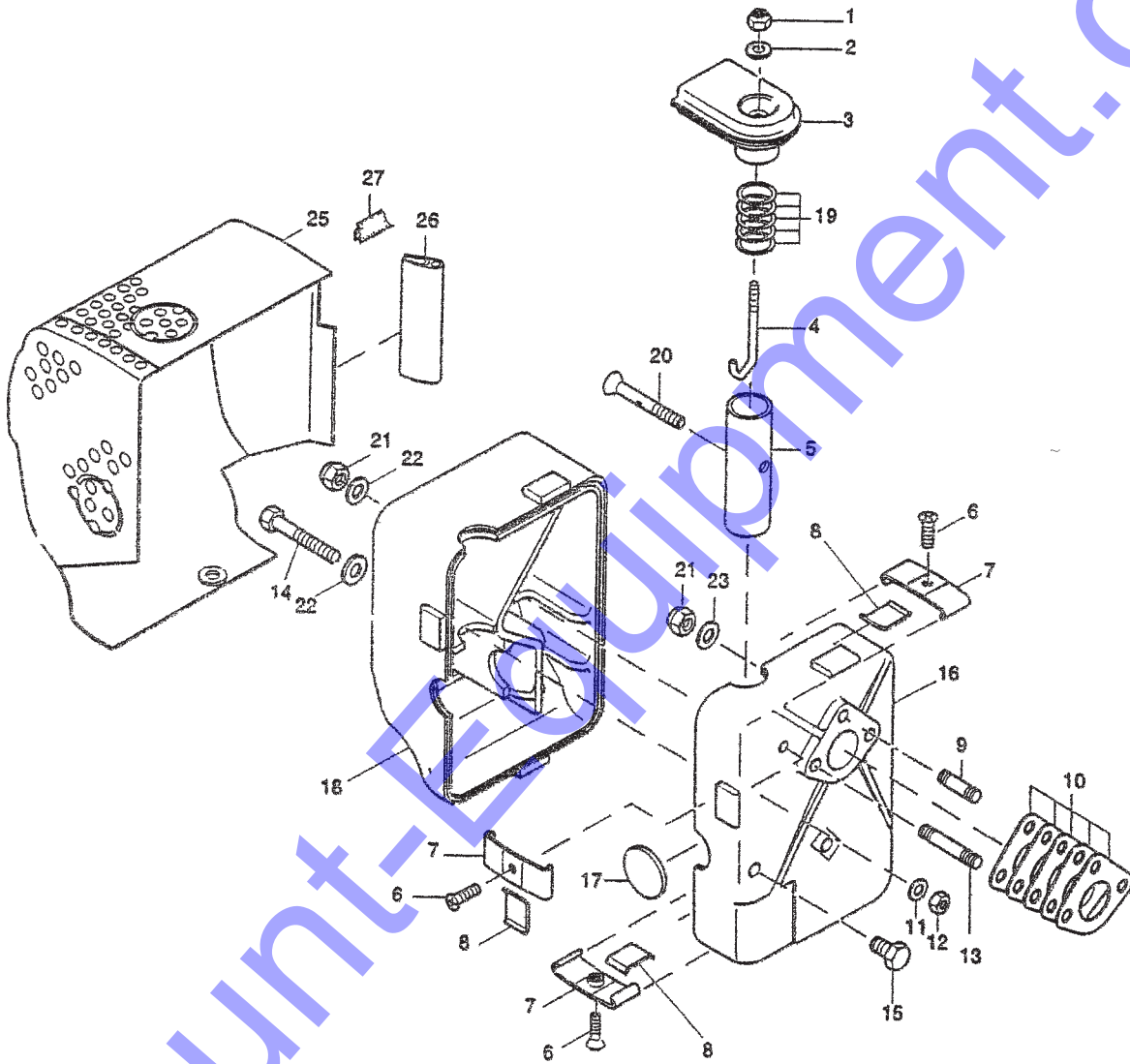

HATZ 1B20 — MUFFLER ASSY.

MUFFLER ASSY.

<u>NO.</u>	<u>PART NO.</u>	<u>PART NAME</u>	<u>QTY.</u>	<u>REMARKS</u>
1	40028300	HEX. NUT M6	1	
2	50144500	FLAT WASHER 6,4	1	
3	01531311	EXHAUST END PIPE	1	
4	05081101	THREADED BOLT M6	1	
5	05081410	EXHAUST TUBE	1	
6	50422500	CTR. SUNK SCREW M6X12	3	
7	01531201	CLAMP	3	
8	05081611	SUPPORTING PLATE	3	
9	50128100	STUD	2	
10	05080100	MUFFLER GASKET 1B20	5 IN HEAD GASKET SET
11	50144500	FLAT WASHER 6,4	1	
12	40028300	HEX NUT M6	1	
13	50039500	STUD M8X110	1	
14	50028800	HEX. SCREW M8X90	1	
15	50450500	HEX. SCREW M8X10	1	
16	01587800	MUFFLER, INNER PART	1	
17	05081002	COVER	1	
18	05077810	MUFFLER, OUTER PART	1	
19	05127000	WASHER, 28.1X34X0.5	5	
20	50445000	CTR. SUNK. SCREW M6X35	1	
21	40028400	HEX NUT M8	3	
22	50148100	FLAT WASHER 8,4	2	
23	50123000	DISK 8,4	2	
25	01532300	MUFFLER GUARD	1	
26	05100300	SEALING STRIP 65MM	1	
27	05135000	SEALING STRIP 33MM	1	

HATZ 1B20 — SEALING AND BONDING ADHESIVES

TABLE 9. SEALING AND BONDING ADHESIVES

Item	Part Number	Description	Amount
A	50223001	Loctite Activator	500 ml
B	50223100	Loctite 573	50 ml
C	50223200	Loctite 601	50 ml
D	50223300	Loctite 221	50 ml
E	50223400	Loctite 648	10 ml
F	50223800 + 50223900	Technicoll 8058 Technicoll 8367	0.75 kg 0.75 kg
G	50256501	Loctite IS 407	10 g
H	50282501	Silicon	30 ml
J	50283003	High Temp Paste	100 ml
K	50342600	High Temp Grease	100 g
L	50256600	Silicon Sealer	100 g

Discount Equipment

Discount-Equipment.com is your online resource for commercial and industrial quality parts and equipment sales.

Locations:

Florida (West Palm Beach): [561-964-4949](tel:561-964-4949)

Outside Florida TOLL FREE: [877-690-3101](tel:877-690-3101)

Need parts? Check out our website at www.discount-equipment.com

Can't find what you need?

Click on this link: <http://www.discount-equipment.com/category/5443-parts/> and fill out the request form.

Please have the machine model and serial number available in order to help us get you the correct parts. One of our experienced staff members will get back to you with a quote for the right part that your machine needs.

We sell worldwide for the brands: Genie, Terex, JLG, MultiQuip, Mayco, Toro/Stone, Diamond Products, Magnum, Airman, Mustang, Power Blanket, Nifty Lift, Atlas Copco, Chicago Pneumatic, Allmand Brothers, Essick, Miller Spreader, Skyjack, Lull, Skytrak, Tsurumi, Husquyarna/Target, Whiteman-Concrete/Mortar, Stow-Concrete/Mortar, Baldor, Wacker, Sakai, Snorkel, Upright, Mi-T-M, Sullair, Neal, Basic, Dynapac, MBW, Weber, Bartell, Bennar Newman, Haulotte, Ditch Runner, Blaw-Knox, Himoina, Best, Buddy, Crown, Edco, Wyco, Bomag, Laymor, Terremite, Barreto, EZ Trench, Takeuchi, Basic, Bil-Jax, Curtis, Gehl, Heli, Honda, ICS/PowerGrit, Puckett, Waldon, ASV, IHI, Partner, Imer, Clipper, MMD, Koshin, Rice, Gorman Rupp, CH&E, Cat Pumps, Comet, General Pump, Giant, AMida, Coleman, NAC, Gradall, Square Shooter, Kent, Stanley, Tamco, Toku, Hatz, Kohler, Robin, Wisconsin, Northrock, Oztec, Toker TK, Rol-Air, Small Line, Wanco, Yanmar