

# OWNER'S MANUAL

**21", 24", 27" BURNISHER**

Powered by the  
EPA/Carb Certified  
Kawasaki  
603cc Engine

Available  
With  
Optional  
Dust Control  
Upgrade

**CE, LEED, CARB, EPA & GS-42 COMPLIANT**

**Discount  
Equipment**

**IMPORTANT SAFETY INSTRUCTIONS**

Read and observe all **DANGER, WARNING, AND CAUTION** statements included in the Owner's Manual and affixed to the machine. These statements indicate that there is a possibility of death, bodily injury, and damage to the machine or property if these instructions are ignored.

 **WARNING**

Do not store or use gasoline or other flammable vapors and liquids in the vicinity of this machine. Always store equipment away from heater rooms, boilers, gas-fired water heaters or any other source of open flame. Propane is highly flammable. Always store LPG tanks (full or empty) outside in a secure, well ventilated area.

**NO SMOKING, NO SPARKS, NO FLAMES NEAR UNIT OR LPG TANK.**

Operate only in well ventilated areas. Buildings must be provided with:

- A. A continuous mechanical ventilation that removes the products of combustion to the outdoors of not less than 300 CFM for each 10,000 BTUH or fraction thereof; or
- B. Natural ventilation of not less than 300 CFM for each 10,000 BTUH input or a fraction thereof; based on a maximum of one-quarter air exchange per hour for the net building volume.

If you smell LPG gas, stop the unit and check for leaks. Also open windows, don't touch electrical switches, extinguish any open flames. Call your gas supplier if no leaks are found.

Do not adjust the fuel system without the proper analysis equipment.

 **DANGER**

This machine emits CO (carbon monoxide), which is a colorless, odorless, non-irritating gas. Symptoms of CO exposure include headache, drowsiness, dizziness and nausea.

If you experience any of these symptoms during machine operation, immediately shut off the machine and go outside for fresh air. Have a qualified service technician test the machine for CO emissions before using it again.

High exposure to CO may result in vomiting, confusion, collapse, loss of consciousness and muscle weakness. If such symptoms occur, call for emergency medical attention. **DO NOT** operate this machine or other propane powered equipment until cleared to do so by a physician. Excessive exposure to CO can result in death.

Never change or alter the propane control components.

This machine is factory equipped with engine components and emission controls that maintain harmful exhaust emissions below certified acceptable levels. Never tamper, adjust, or remove any factory installed engine components for purposes other than maintenance, repair or replacement.

Never tilt the equipment on its side for pad, belt or brush replacement. It is designed to tilt back on its rear wheel and handle for maintenance and repair. A second person should aid in lifting and securing equipment for repair.

Never tilt & transport while engine is running.

Keep hands and feet clear of all moving parts.

Never try to replace parts or repair equipment with machine running.

Turn the gas off at the tank to kill the engine.

Remove the LPG tank and store it in an approved area when not in use. A "NO SMOKING" sign should be permanently displayed at the storage area.

Always vent an over-full bottle using the tank's bleed valve, out of doors away from all closed places and away from any fire or flame producing device. Vent until the white vapor turns clear.

This machine is intended for use with vapor withdraw propane cylinders only. NEVER use a liquid withdraw propane cylinder with this equipment. **DO NOT** overfill the cylinder. If the regulator or regulator connection freezes, stop the machine and take the cylinder outdoors. Inspect cylinder and purge the cylinder using the bleeder valve if necessary.



VAPOR ONLY !  
VAPEUR SEULEMENT !  
VAPOR SOLO !



NO LIQUID !  
NINGUN LIQUIDO !  
AUCUN LIQUIDE !

**Keep all objects clear of the exhaust system during and after operation.**

**Do not leave this machine unattended while the engine is running.**



## WARNING

**Do not operate equipment in one location for more than a few seconds. Damage to floor surface can occur.**

**Always store equipment away from possible damage by falling objects in warehouse-type areas. Always store LPG tanks outside in a secure, well-ventilated area.**

**The muffler and engine become hot enough during operation to cause severe burns.**

**NOTE:** The exhaust system will be very hot and takes several minutes to cool, so keep yourself and all materials clear.

**Safety goggles, safety shoes and safety clothing are recommended while operating the machine.**

**Continuous exposure to high noise levels can cause hearing loss. Hearing protection is recommended while the machine is in operation.**

**The operational weighted sound level of this machine is less than 89dB(A).**

**Prolonged exposure to machine vibration may cause tingling or numbness in the fingers and hands. Use of gloves and limits to operator vibration exposure are recommended to prevent such symptoms. The operational hand/arm vibration level of this machine is less than 2.5m/s<sup>2</sup>.**

**The machine should not be used in nursing homes, hospitals, day-care centers, etc., while they are occupied. Avoid use in areas with obstruction such as thresholds and floor outlet boxes. Avoid use in areas with loose debris or small objects that may become caught in the rotating pad.**

**When LPG tank is attached to the machine and not running, the operator should not leave the machine unattended except for short periods of time such as rest stops, washroom or meal stops.**

**The operator must completely understand all instructions, warning and operating procedures before using this machine.**

**The manufacturer's warranty will be voided if the machine is not maintained in accordance with this manual's recommended maintenance**

**instructions and the engine manufacturer's recommended maintenance procedures. Failure to do so may cause damage to the machine, equipment, furniture, buildings or personal injury! A maintenance record should be kept indicating date of service, hours on engine, and work done.**

## GUIDE TO GRAPHICAL SYMBOLS AND PRODUCT LABELS



Read all instructions before using



Hot surface – Do Not Touch



Wear hearing protection when operating



Wear safety goggles when operating



Switch "On" Position



Switch "Off" position

Refer to page 9 of this manual for a location and description of all safety labels and controls.

## TRANSPORT & PREPARATION



## WARNING

**Follow the instructions given in this booklet, the Engine's Owners Manual and the training given by your supervisor for the safe operation of this machine. Failure to do so can result in personal injury and/or damage to the machine or property.**

**DO NOT OPERATE THIS MACHINE IN AN EXPLOSIVE ENVIRONMENT!**

**THIS PROPANE MACHINE IS INTENDED FOR COMMERCIAL USE.**

**CAUTION**

**Do not use "T" handle when attempting to tilt back machine for service or cleaning. The "T" handle is designed for control during operation only.**

**Do not use excessive vertical pressure.**

**I. PREPARATION****A. Check that the suggested maintenance schedule has been observed:**

All machines are equipped with a multi-function maintenance meter. The functions include the following: hour meter, service alert and tachometer. (See Engine Maintenance Meter Instructions on pg5).

**B. Check the engine oil before every operation:**

Make sure the machine is level when checking the oil. Always take 2 readings of the dipstick before adding oil. If the oil level is below the full mark, add just enough oil to the engine to bring the oil level up to the full mark. **Never over fill.** Follow the guidelines in your Engine Owners Manual. Check for foreign material on the dipstick.

**C. Properly fill and check your LPG tank and all LPG fuel lines for leaks:**

1. Every tank has been pressure and leak tested. However, every time a tank is filled and/or connected to the machine it should be soap tested. All LPG lines must be pressurized and every inch of line and connections must be sprayed. If you find a leak, make the proper repairs before operating the machine.

**NOTE:** The connection and disconnection of the LPG tank must be done in a well ventilated area with NO source of ignition within 10 feet (3 meters) from the point of connection.

2. **Never over fill the LPG tank!** The LPG tank is designed to hold just 20 pounds of propane. Make sure to weigh the tank as it is being filled. The gross weight of a full tank should not exceed 48 pounds. If while operating the machine, you notice frost forming on the LPG lines or the regulator, your tank has been over filled. If you continue to operate the machine in this condition, damage will occur. The excess propane in the tank must be removed before normal operations resume. The bleeding of a propane tank should be done in a safe location outside the building. In some cases the regulator must defrost before restarting the engine.

**D. Connecting the high pressure hose to the LPG Tank:**

Make sure the couplers are in line and screwed together hand tight. If this is not done properly, fuel will not pass through to the regulator. Never complete the connection of the tanks to the machine by using a wrench. Always do it by hand. Listen for the rush of fuel to the lock-out device when you open the tank valve. If you hear this, it indicates a good connection has been made at the tank.

**E. Install fresh pads or brushes before every job:**

To install a fresh pad, set the machine down in the rear. Unscrew and remove the pad-centering ring. Remove the old pad and center the new pad onto the pad driver. Reinstall the pad-centering ring. Never "flip" a pad. Keep the same side down throughout the life of the pad. Even after a pad is cleaned, you can tell the down side by the centering ring indentation. This practice will increase the pad life and help maintain a properly functioning pad driver.

**NEVER TILT A MACHINE ON ITS SIDE!**

**DO NOT use machine with a damaged or disintegrated pad to avoid excess vibration.**

**II. STARTING THE ENGINE**

**A.** Open propane (LPG) tank valve (counter clockwise).

**B.** Set throttle control at idle.

**C.** Battery start – turn key to the start position & move throttle toward fast position. If engine does not start, release key and return to step "B".

- **When a propane tank is overfilled it may temporarily cause the fuel regulator to malfunction. Remove the tank to a well ventilated location. Release some gas until the cloud disappears and escaping gas is "clear." Reinstall tank.**
- **All machines are equipped with tamper proof fuel systems. If a fuel problem exists, contact an authorized service center.**
- **Propane tanks should be removed & stored in a protected off site area.**

### III. OPERATION

*Provide and use ear protection during operation.*

*Never let an untrained person operate or perform repairs on the machine. They may hurt themselves, damage the floor or the equipment.*

*Engine speed not to exceed 3400 RPM.*

*This machine is not suitable for picking up hazardous dust.*

*Do not use on surfaces with a gradient exceeding 2%.*

### IV. STOPPING THE ENGINE

*Turn the propane tank valve clockwise to a closed position and turn the key OFF.*

***NOTE:** The exhaust system will be very hot and takes several minutes to cool, so keep yourself and all materials clear.*

### V. PROCEDURES

*Follow machine (straight ahead) at moderate walking speed. Keep moving.*

- Do not operate the machine in one location for more than a few seconds — it will damage — “burn” the finish.*
- When operation is completed remove tank and store in a secure, protected off site (preferably outdoor) location.*
- Do not use for scrubbing operations.*
- Never tilt back machine to maintenance position while engine is running.*
- Never reach under protective shroud when engine is running.*

### VI. MAINTENANCE

#### A. Machine & engine maintenance

- 1. Refer to engine manufacturer's owners manual and comply completely with the instructions. Change the oil and filter according to the Engine Owners Manual.*
- 2. Keep a good service log on each machine with the date, hour meter reading, type(s) of service performed and the name of the person who performed them.*
- 3. Clean the entire unit after each use. When cleaning the unit, check for possible loose nuts and bolts.*
- 4. The foam engine dust filter should be removed and cleaned periodically by shaking out the accumulated dust and rinsing with water and a mild detergent. Squeeze out the excess water (do not wring out). Allow the filter to air dry*

*before replacing. Failure to keep the engine dust filter clean may result in engine overheating.*

#### B. Engine maintenance meter

*This multi-function meter acts as a preventive maintenance tool, which benefits you with increased fuel economy, less down-time and longer engine life.*

***The meter's displays are:***

***Hour Meter:** Displays total run hours when machine is off.*

***Tachometer:** Indicates engine RPM during operation.*

***Service Alert:** Change oil after **first 8 hours of operation.** Thereafter change oil **every 50 hours.***

*The display flashes to alert you to lube and change the oil at 25 hour intervals. The service alert only flashes during operation and it warns you to change the oil for only two hours. After the two hours is reached, the alert will automatically reset to the next 25 hour interval. Therefore, it is recommended that a separate maintenance log be kept to track oil changes.*

***Remember that being safe is a full-time, every day job. Follow all information posted on the machine and the LPG tank.***

***Never allow anyone to operate this machine who has not read or cannot understand the given instructions.***

#### C. Troubleshooting the electrical system

- 1. Check all wire connections for obvious problems. Remove LPG tank, then remove battery box cover. Check all connections visibly and physically. If any “loose”, damaged or unconnected wires are noticed, replace or repair as needed.*
- 2. Check the battery posts and wires. **Always wear a face shield, safety glasses and protective clothing when working around a battery!** The gases can be explosive and the acid is highly corrosive to metals, cloth and ALL HUMAN TISSUE (skin, eyes, etc.) If the battery post(s) are corroded, remove the wires and clean posts and wires. Applying some axle grease on the posts of the battery after they are cleaned will slow down the battery corrosion process.*  
*If nothing obvious is noted, a more detailed investigation is warranted. Before any such troubleshooting begins, the following things should be done:*
  - a. Replace propane LPG tank with one from a machine that runs.*



b. Charge the battery or provide an absolute source of 12 volt DC power capable of 50 amperes total output. (A pair of good jumper cables from your car or truck battery will suffice.) Equip yourself with an inexpensive 12 volt test light.

c. If the trouble seems to be in the electrical control equipment, you may wish to disconnect the starter from the system so as to check the system without spinning the engine.

d. Battery rundown. A common problem is letting the battery run down. What usually happens is that it takes the crew a few jobs to get used to the whole system, so the machine is stopped and started quite often. Key left in on position, when engine is turned off, will result in battery running down – dying.

**D. Belt Inspection & Replacement**

**Inspection**

- Fold T-Handle to forward position
- Tilt machine back on rear of body & handle
- If belt is worn, cracked or shredding, belt needs to be replaced.

**Replacement**

- Place 3/4" wrench on end of the shaft on the top of the buffer body.
- Turn pad driver counter-clockwise to remove.
- Take belt off by turning 3/4" wrench on shaft and removing belt from pad driver pulley and engine crank pulley.
- Check pad driver pulley & engine crank pulley for correct alignment.
- Install new belt on engine crank pulley & pad driver pulley, using 3/4" wrench.
- Install belt on tension pulley
- Install pad drive onto shaft, and return buffer to operating position.

**E. Adjusting Pad Pressure**

The pad pressure may be adjusted by moving the wheels:

- Forward to reduce weight on the buffer pad or
- Backward to increase the weight

This adjustment may be required to adjust to different floor finishes or to the weight variance of aluminum or steel propane tanks.

**KAWASAKI ENGINES**

**Tune-up Specifications**

ITEM	SPECIFICATIONS
Ignition Timing	Unadjustable
Spark Plugs: Gap	NGK - BPR4ES 0.75 mm (0.30 in)
Low Idle Speed	1500 RPM
High Idle Speed	3400 RPM
Valve Clearance	IN: 0.10-0.15 mm (0.004-0.006 in) EX: 0.10-0.15 mm (0.004-0.006 in)
Other Specifications	No other adjustment needed

**NOTE:** High and low idle speeds may vary depending on the equipment on which the engine is used. Refer to the equipment specifications.

**Engine Oil**

Check the engine oil daily before starting the engine otherwise shortage of the engine oil may cause serious damage to the engine such as seizure.

- Place the engine on a level surface. Clean the area around the oil gauge before removing it.
- Remove the oil gauge and wipe it with a clean cloth.
- Pour the oil slowly to “FULL” mark on the oil gauge.
- Insert the oil gauge into the tube WITHOUT SCREWING IT IN.
- Remove the oil gauge to check the oil level. The oil level should be between “ADD” and “FULL” marks. Do not overfill.
- Install and tighten the oil gauge.

**The following engine oils are recommended:**

API Service Classification: SF, SG, SH, or SJ.

**Oil Viscosity**

Choose the viscosity according to the temperature as follows:

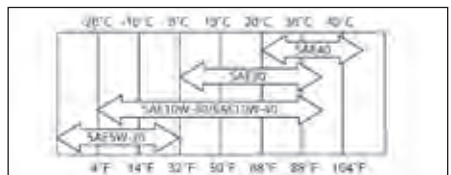

**NOTE:** Using multi grade oils (5W-20, 10W-30, and 10W-40) will increase oil consumption. Check oil level more frequently.

**Engine Oil Capacity**

FS481	1.5 L (1.6 US qt.) when oil filter is not removed
	1.7 L (1.8 US qt.) when oil filter is removed
	1.7 L (1.8 US qt.) when oil filter is removed

**Oil Change**

Change oil after **first 8 hours of operation**. Thereafter change oil **every 50 hours**.

- Run the engine to warm oil.
- Be sure the engine (equipment) is level.
- Stop the engine.
- Open the oil drain valve and drain the oil into suitable container while engine is warm.

**WARNING!**

**Hot engine oil can cause severe burns. Allow engine temperature to drop from hot to warm level before draining and handling oil.**

**Oil Drain Plug**

- Close the oil drain valve.
- Remove oil gauge and refill with fresh oil (See "Recommended Oils" on pg 6).
- Check the oil level (see "Preparation" on pg 6) for oil level check).

**Oil Filter Change**

- Change the oil filter **every 100 hours** of operation.

**CAUTION!**

**Before removing the oil filter, place a suitable pan under filter connection.**

- Drain engine oil into a suitable container.
- Rotate the oil filter (A) counterclockwise to remove it.
- Coat a film of clean engine oil on seal of new filter.
- Install new filter rotating it clockwise until seal contacts mounting surface (B). Then rotate filter 3/4 turn more by hand.
- Supply engine oil as specified.
- Run the engine for about 3 minutes, stop engine, and check oil leakage around the filter.
- Add oil to compensate for oil level drop due to oil filter capacity (See "Oil Level Check" on pg 6).

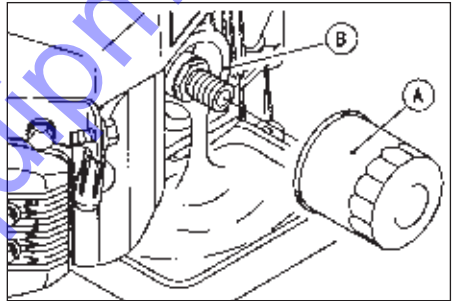

**WARNING!**

**Engine oil is a toxic substance. Dispose of used oil properly. Contact your local authorities for approved disposal methods or possible recycling.**

**KAWASAKI ENGINE BATTERY START WIRING DIAGRAM**

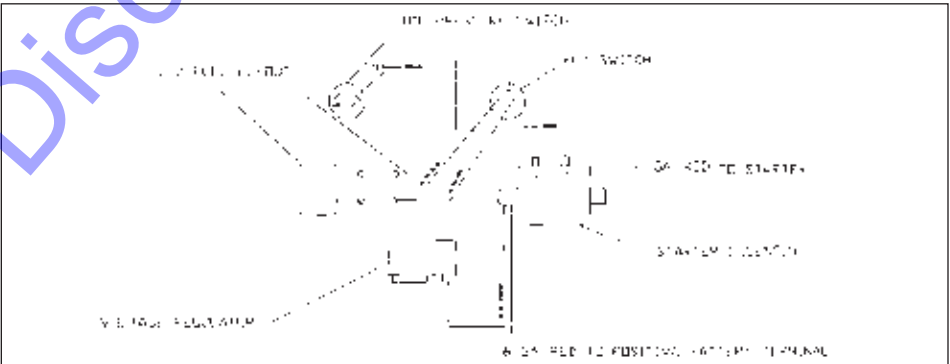

## KAWASAKI ENGINE MAINTENANCE SCHEDULE

MAINTENANCE	INTERVAL						
	Daily	First 8 hr.	Every 25 Hr.	Every 50 hr.	Every 100 hr.	Every 200 hr.	Every 300 hr.
Check and add engine oil	•						
Check for loose or lost nuts and screws	•						
Check for fuel and oil leakage	•						
Check battery electrolyte level	•						
Check or clean air intake screen	•						
Clean air cleaner foam element			•				
Clean air cleaner paper element				•			
Clean dust and dirt from cylinder and cylinder head fins						•	
Tighten nuts and screws						•	
Change engine oil		•		•			
Clean and gap spark plugs						•	
Change oil filter						•	
Replace air cleaner paper element						•	
Clean combustion chambers							•
Clean and adjust valve clearance				•*			•
Clean and lap valve seating surface							•

\*After the 1st 50 hours

## ENGINE TROUBLESHOOTING

### COMMON PROBLEMS & PROBABLE CAUSES

#### Engine cranks but will not start

- Fuel cylinder is empty
- Shutoff valve is closed
- Clogged, obstructed, kinked or cut fuel or vacuum line
- Spark plug lead disconnected
- Faulty choke or throttle settings
- Faulty ignition coil
- Faulty kill switch
- Faulty regulator

#### Engine starts hard

- Faulty choke or throttle settings
- Clogged, obstructed, kinked or cut fuel or vacuum line
- Faulty regulator
- Low compression

#### Engine will not crank

- Battery is discharged
- Loose or faulty connections or wires
- Faulty ignition key switch or starter control switch

#### Engine overheats

- Incorrect fuel settings
- Air intake filter screen or cooling fins clogged
- Low oil level

#### Exhaust emissions or propane odor

- Carburetor or regulator setting incorrect
- Dirty or clogged air filter
- Choke engaged
- Loose fittings, clamps or hoses cracked, hoses cut or leaking

### SOLUTIONS

Refill cylinder  
 Open valve  
 Remove obstruction or replace line  
 Connect lead to spark plug  
 Set controls to correct positions  
 Replace coil  
 Replace switch  
 Replace regulator

Set controls to correct position  
 Remove obstruction or replace line  
 Replace regulator  
 Valves need adjustment  
 Have engine serviced by a trained technician

Charge or replace battery  
 Tighten, repair or replace wires  
 Repair or replace switch(es)

Have engine serviced  
 Clean and clear debris or replace filter  
 Check and add oil

Have engine serviced by a trained technician  
 Replace air filter  
 Adjust to correct settings  
 Tighten or seal; check with soap and water solution, if bubbles appear, part is still leaking; replace





# Warning Label Locations



Discount-Equipment.com

## Quick Start Guide

1. Read, understand and observe all Important Safety Instructions before operating the machine (See Pg. 2).
2. Make sure the machine is properly maintained prior to use (See Pg. 2 & 10).
3. Make sure the LPG tank (A) is filled, connected and checked for leaks. (See Pg. 2 & 3).
4. Open the LPG tank by turning the knob (B) counter clockwise.
5. Set the throttle lever (C) to idle [  ] position.
6. Turn key (D) to start [  ] position.
7. Move throttle lever (C) toward run [  ] position. If motor fails to start, return to Step 5 above.
8. Set throttle lever (C) to desired operating speed and follow the moving machine (straight ahead) at moderate walking pace (keep moving).

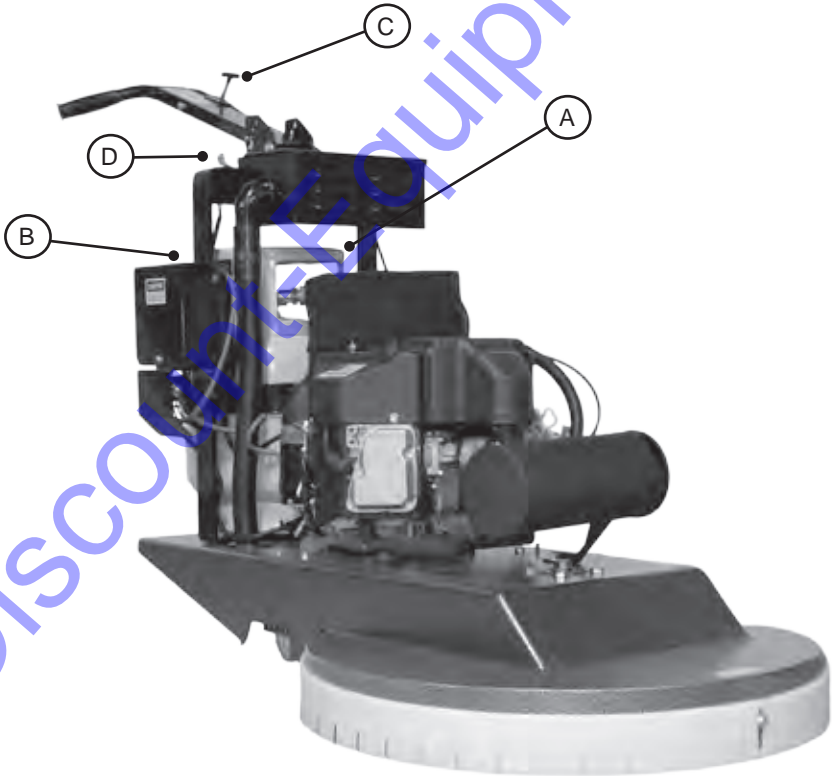

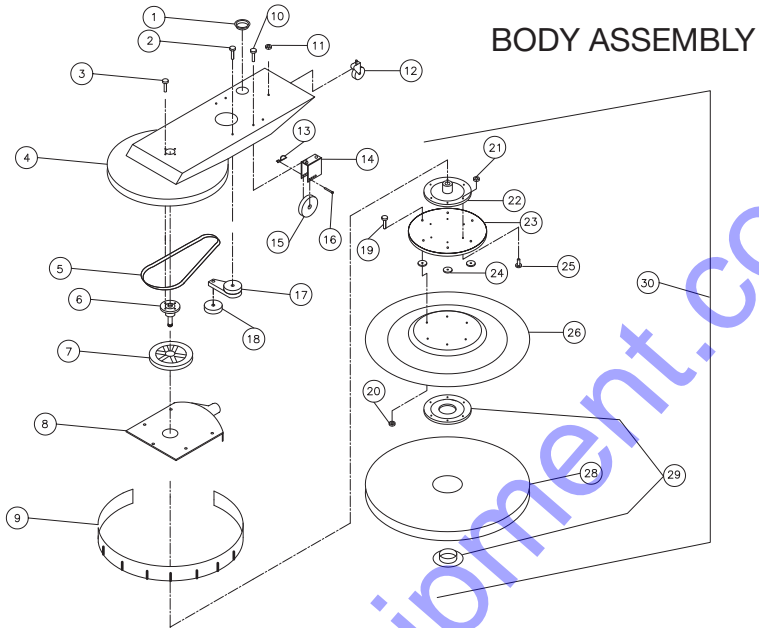

**PARTS LIST FOR 21", 24", 27" BODY ASSEMBLY**

REF #	DESCRIPTION	PART #	QTY
1	HOSE GROMMET	625-9280K35	1
2	3/8-16x2" BOLT	164-10123	1
3	1/2-13x1" BOLT	164-10211	4
4	BODY ASSEMBLY (21") : (24") : (27")	(283-21-5) : (283-24-5) : (283-27-5)	1
5	BELT (21") : (24") : (27")	(113-BX42) : (113-BX49) : (113-BX51)	1
6	SPINDLE ASSEMBLY	011-6-2730	1
7	PULLEY (21") : (24") : (27")	(172-MB65*1) : (011-6-2785) : (172-MB88*1)	1
8	DUST CONTROL PLATE (21") : (24") : (27")	(283-21-6) : (283-24-6) : (288-070-10)	1
9	DUST SKIRT (21") : (24") : (27")	(070-21DC-SKIRT) : (070-24DC-SKIRT) : (070-27DC-SKIRT)	1
10	5/16-18x1" BOLT	164-10063	4
11	1/2-13 HEX NUT	164-22008	1
12	SWIVEL CASTER	011-6-2755	1
13	PIN CLIP	011-6-2762	2
14	WHEEL LEG	011-6-2760	2
15	6" WHEEL	156-6-213P	2
16	CLEVIS PIN	011-6-2761	2
17	BELT TENSIONER	011-6-2795	1
18	TENSIONER PULLEY	011-6-2795A	1
19	1 1/2" ELEVATOR BOLT	164-31C150 BELZ	6
20	5/16-18 NYLOK NUT	164-22509	6
21	5/16-18 NYLOK NUT	164-22509	6
22	HUB	107-DC-100	1
23	FLEX PLATE	307-DC-400	1
24	RISERS	307-DC-500	6
25	1 1/4" ELEVATOR BOLT	164-31C125BELZ	6
26	FLEX LOK W/ RISER (21") : (24") : (27")	(070-21-10) : (070-24-10) : (070-27-10)	1
28	PAD (21") : (24") : (27")	(250-PT21) : (250-PT24) : (250-PT27)	1
29	BIG MOUTH PAD GRAB	201-792455	1
30	PAD DRIVER ASSEMBLY (21") : (24") : (27")	(070-21-PD) : (070-24-PD) : (070-27-PD)	1

## HANDLE ASSEMBLY

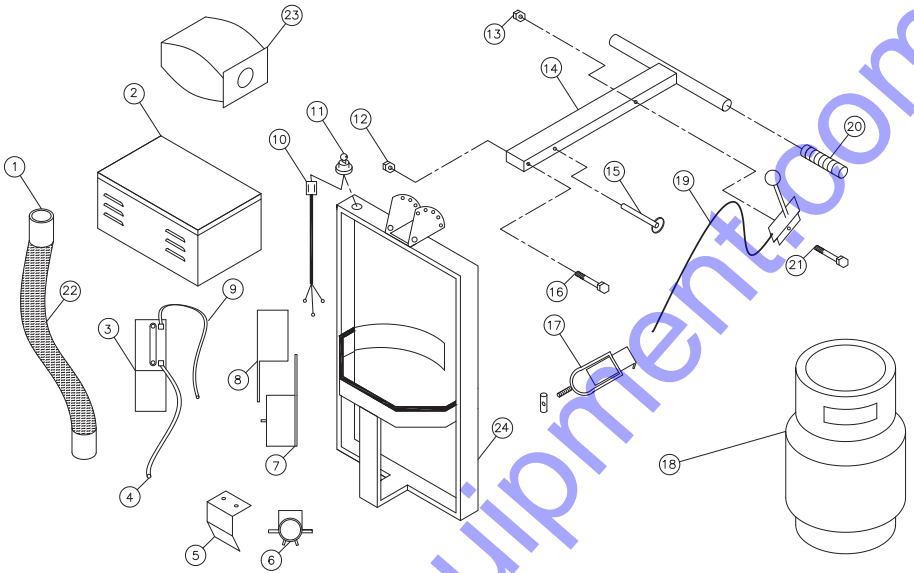

### PARTS LIST FOR HANDLE ASSEMBLY

1	HOSE CUFF	S2-47-CUFF	2
2	DUST BAG BOX ASSEMBLY	288-070-5	1
3	12V BATTERY	276-GTX14	1
4	(+) BATTERY CABLE	153-6-16.5	2
5	SOLENOID COVER	283-11-SC	1
6	STARTER SOLENOID	296-SS581	1
7	BATTERY BOX BOTTOM	283-11-2127B	1
8	BATTERY BOX TOP	283-11-2127T	1
9	(-) BATTERY CABLE	153-6-26	1
10	WIRE HARNESS	011-762WHK	1
11	KEY SWITCH	312-308-0385	1
12	3/8-16 LOK NUT	164-22834	1
13	1/4-20 FLANGE NUT	164-14FN	1
14	T-HANDLE	283-27-25	1
15	RELEASE PIN	625-98404A395	1
16	3/8-16x3 3/4 BOLT	164-37C375HCS5Z	1
17	TOGGLE + NUT	284-TB2-60	1
18	20# LP CYLINDER	293-20#STLMF	1
19	THROTTLE CABLE	212-1	1
20	HANDLE GRIPS	224-987319	2
21	1/2-20x3 3/4 BOLT	164-25C375HCS5Z	1
22	DUST HOSE	S2-47	3
23	DUST BAG	070-DC-BAG	1
24	HANDLE ASSEMBLY	283-27-20	1

FUEL SYSTEM

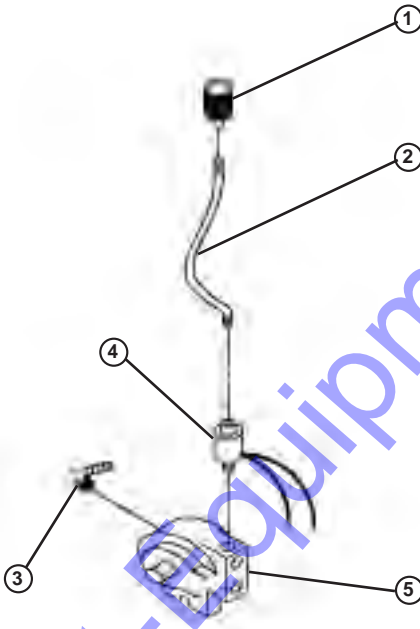

12 VOLT START  
MODELS

**PARTS LIST FOR BUFFER FUEL SYSTEM**

<b>PART #</b>	<b>DESCRIPTION</b>	<b>PART #</b>	<b>QTY</b>
1	QUICK COUPLER	152-700	1
2	LPG HOSE 20"	267-P5561-0410	1
3	FUEL HOSE FITTING	166-62040	1
4	FUEL LOK-OUT (12 VOLT)	152-N3-0173-1	1
5	FUEL REGULATOR (T60-E)	152-500	1



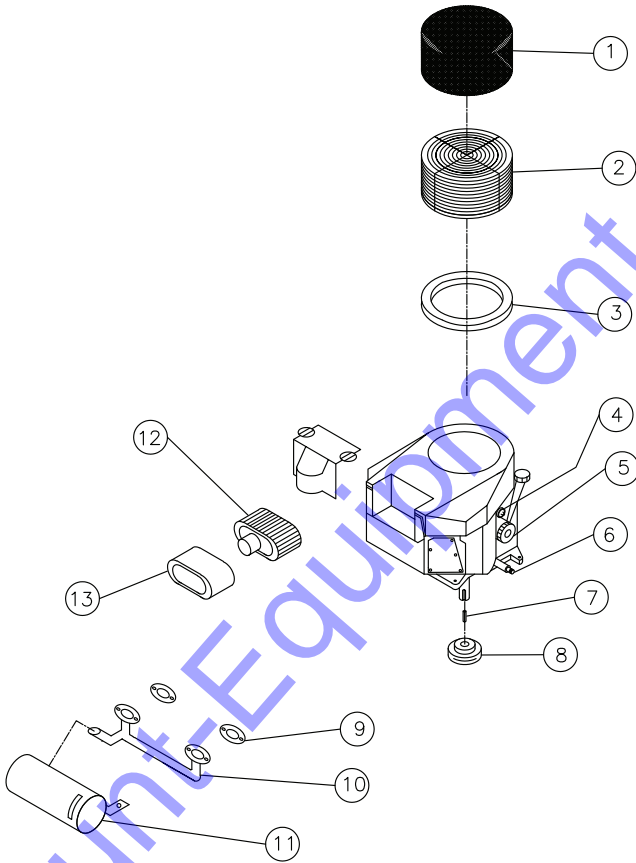

**KAWASAKI 603cc ENGINE**

PART #	DESCRIPTION	PART #	QTY
1.	Foam Hat Filter	186-271964	(1)
2.	Debris Screen	309-18540-603	(1)
3.	Foam Hat Seal	175-8.25*9.75*1	(1)
4.	Oil Pressure Switch	152-N3-0082	(1)
5.	Oil Filter	309-49065-7007	(1)
6.	Oil Drain Valve	312-504-0185	(1)
7.	1 / 4 x 1 1 / 4 Key	199-NHNT-SE UND	(1)
8.	Crank Pulley	011-6-2780	(1)
9.	Exhaust Manifold Gasket	309-11060-7016	(2)
10.	Exhaust Manifold	152-603-MAN	(1)
11.	Catalytic Muffler	152-603-MUF	(1)
12.	Air Filter Element	309-11013-7049	(1)
13.	Foam Pre Filter	309-11013-7046	(1)