

# Operator's Assembly and Parts Manual

## Max Mix Concrete Mixer



[www.discount-equipment.com](http://www.discount-equipment.com)



It is the OWNER'S RESPONSABILITY to communicate information on the  
SAFE USE and OPERATION of this machine to the operators.

# **Discount Equipment**

Discount-Equipment.com is your online resource for commercial and industrial quality parts and equipment sales.

## **Locations:**

Florida (West Palm Beach): [561-964-4949](tel:561-964-4949)

Outside Florida TOLL FREE: [877-690-3101](tel:877-690-3101)

**Need parts?** Check out our website at [www.discount-equipment.com](http://www.discount-equipment.com)

## **Can't find what you need?**

Click on this link: <http://www.discount-equipment.com/category/5443-parts/> and fill out the request form.

Please have the machine model and serial number available in order to help us get you the correct parts. One of our experienced staff members will get back to you with a quote for the right part that your machine needs.

We sell worldwide for the brands: Genie, Terex, JLG, MultiQuip, Mayco, Toro/Stone, Diamond Products, Magnum, Airman, Mustang, Power Blanket, Nifty Lift, Atlas Copco, Chicago Pneumatic, Allmand Brothers, Essick, Miller Spreader, Skyjack, Lull, Skytrak, Tsurumi, Husquyarna/Target, Whiteman-Concrete/Mortar, Stow-Concrete/Mortar, Baldor, Wacker, Sakai, Snorkel, Upright, Mi-T-M, Sullair, Neal, Basic, Dynapac, MBW, Weber, Bartell, Bennar Newman, Haulotte, Ditch Runner, Blaw-Knox, Himoina, Best, Buddy, Crown, Edco, Wyco, Bomag, Laymor, Terremite, Barreto, EZ Trench, Takeuchi, Basic, Bil-Jax, Curtis, Gehl, Heli, Honda, ICS/PowerGrit, Puckett, Waldon, ASV, IHI, Partner, Imer, Clipper, MMD, Koshin, Rice, Gorman Rupp, CH&E, Cat Pumps, Comet, General Pump, Giant, AMida, Coleman, NAC, Gradall, Square Shooter, Kent, Stanley, Tamco, Toku, Hatz, Kohler, Robin, Wisconsin, Northrock, Oztec, Toker TK, Rol-Air, Small Line, Wanco, Yanmar

## MAX MIX SERVICE & ASSEMBLY MANUAL

You will need the manual for safety warnings and precautions, assembly instructions operating and maintenance procedures, parts list and diagram. Keep your invoice with this manual for your record. Keep manual and invoice in a safe and dry place for future reference.

### Safety Warnings and Precautions

WARNING: When using this equipment, basic safety precautions should always be followed to reduce the risk of personal injury and damage to equipment.

### Read all instructions before using this equipment

- 1. Keep work area clean.** Cluttered areas can cause injuries.
- 2. Observe work area conditions.** Do not use machines or power tool in damp or wet locations. Do not expose to rain. Work in a well-lighted area.  
Do not use electrically powered tools in presence of flammable gases or liquids.
- 3. Keep Children away.** Children must never be allowed in the work area.  
Do not let them handle machines, tools or extension cords.
- 4. Store idle equipment.** When not in use tools & equipment must be stores in a dry location to inhibit rust. Always Lock up tools and keep out of reach of children
- 5. Do not force equipment.** This unit will perform better and safer at its intended rate. Do not use inappropriate attachments in an attempt to exceed the capacity/capability.
- 6. Use the right equipment for the job.** Do not attempt to use this unit as a larger industrial mixer, do not use this unit for a purpose for which it was not intended.
- 7. Dress Properly.** Do not wear loose clothing or jewelry as they can be caught in moving parts. Protective electrically non-conductive clothes and non-skid footwear are recommended when working. Wear restrictive hair covering to contain long hair.
- 8. Use eye and ear protection.** Always wear ANSI (American National Standards Institute) approved impact safety goggles, wear a full face shield if you are producing metal fillings or wood chips. Wear an ANSI approved dust mask or respirator when working around metal, wood, and chemical dust and mists.
- 9. Do not overreach.** Keep proper footing and balance at all times. Do not reach over or across running machines.
- 10. Maintain Equipment with care.** Keep the unit clean for better and safer panoramic. Follow instructions for lubricating and changing accessories. Inspect cords periodically and if damaged, have them repaired by an authorized technician. The handle must be kept clean, dry and free from oil and grease at all times.
- 11. Disconnect power.** Unplug when not in use, or when cleaning, lubricating, or adjusting the mixer.
- 12. Remove adjust keys and wrenches.** Check that keys and adjusting wrenches are removed from the unit or work surface before plugging it in.
- 13. Avoid unintentional starting.** Be sure the switch is in the OFF position when not in use and before plugging in.
- 14. Stay alert.** Watch what you are doing, use common sense. Do not operate this unit when you tired.

- 15. Check for damaged parts.** Before using this equipment, any part that appears damaged should be carefully checked to determine that it will operate properly and perform its intended function. Check for alignment and binding of moving parts: any broken parts or mounting fixtures: and any other condition that may affect proper operation. Any part that is damaged should be properly repaired or replaced by a qualified technician. Do not use this unit if any switch do not turn ON an OFF properly.
- 16. Guard against electric shock.** Prevent body contact with grounded surfaces such as pipes, radiators, ranges and refrigerator enclosures.
- 17. Replacement parts and accessories.** When servicing, use only identical replacement parts. Use of any other parts will void the warranty.
- 18. Keep safe clearance around mixer.** Keep all people (except operator) a minimum of six feet from the mixer during operation.
- 19. Do not overload mixer.** An Overload could damage this unit.
- 20. Do not move mixer during operation.** The mixer could tip over or the motor could be damaged.
- 21. Do not operate mixer under the influence of alcohol or drugged.** Read warning labels on prescription to determine if your judgment or reflexes are impaired while taking drugs. If there is any doubt, do not operate this unit.

## Unpacking

When unpacking, check to make sure that all components are included as per the following list:

- 1 MOTOR
- 1 DRUM COMPLETE
- 1 DRUM GASKET (SEAL)
- 2 PADDLES
- 1 MOTOR COVER
- 1 AXLE FRAME
- 1 FRAME BASE
- 2 X 10" WHEELS
- 2 HANDLES WITH GRIPS
- 1 PEDESTAL ASSEMBLY (4 LEGS)
- 1 RUBBER WASHER
- 1 T-BOLT
- 24 ASSORTED BOLTS
- 26 ASSORTED WASHERS
- 24 ASSORTED HEX NUTS
- 1 PIN COTTER

FOR MORE DETAILS SEE PARTS BREAKDOWN

## ASSEMBLY

1. Using the M8 x 70 mm long bolts, nuts & washers attached the rear leg stand.

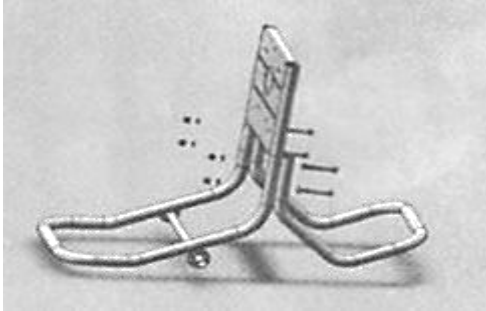

12. Mount the motor Cover.

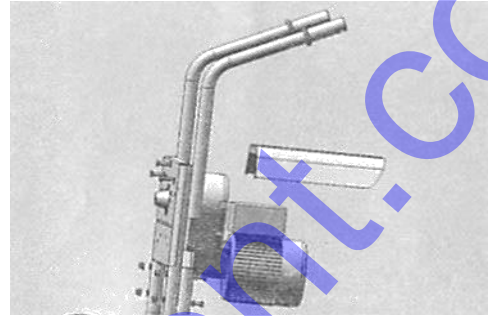

2. Fit the 2 wheels to wheel axles and tighten with hex bolt M8 x 16 bolt and washer.

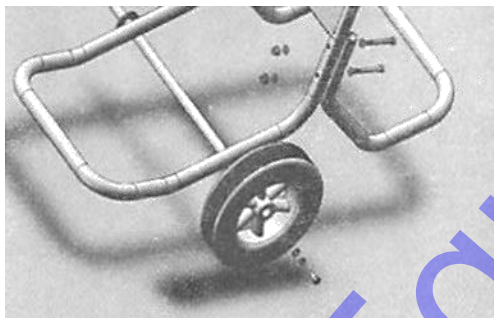

13. Next, slide the drum onto the driveshaft, then anchor the drum in place with the T-bolt and T-Bolt washer. Push the drum up onto the driveshaft while at the same time tighten the T-Bolt by hand. Once the T-bolt is tightened as much as possible by hand, give it a whack with a rubber hammer.

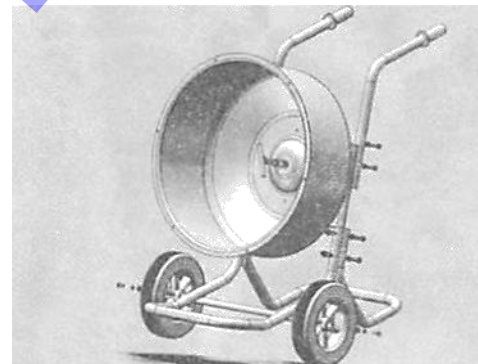

3. Using the M8 x 70 mm long bolts, nuts & washer attached the handles.

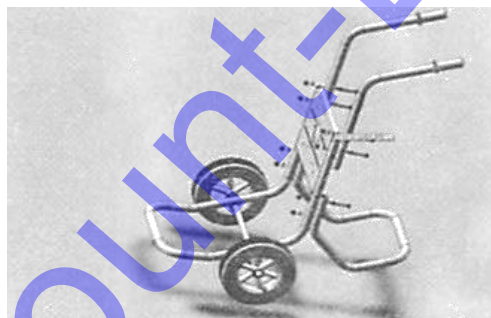

4. Fit the motor and gearbox assembly using the M8 x 16 bolts, nuts & washer.

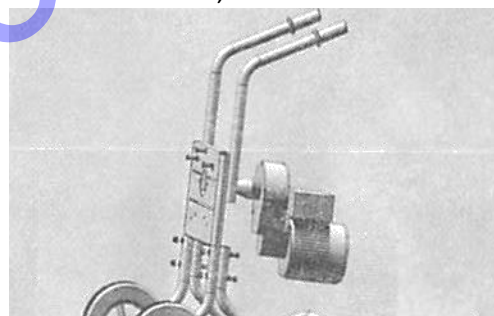

14. Mount each mixer paddle inside the assembled drum with the pointed end facing downwards. Also the V-shaped bend in the mixer should be pointed in the direction of the drum rotation (clockwise). Use the M8 x 20 mm Hex bolt washer and hex flange nut to secure the unit to the lower mounting holes.

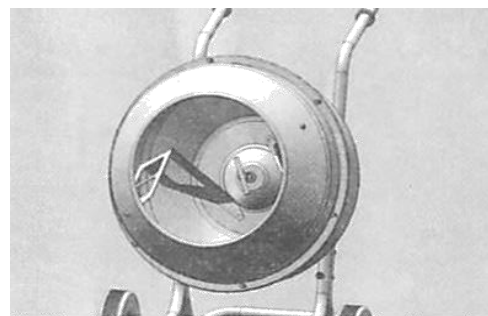



8. Place the rubber gasket to the upper drum making sure the holes align in both drum halves.

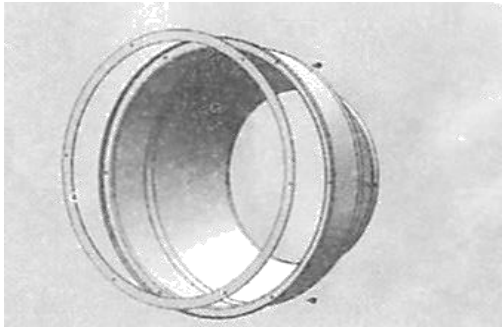

10. Use the M8 x 16 hex bolt, washer & nut to secure each mixer drum half and tight the bolts.

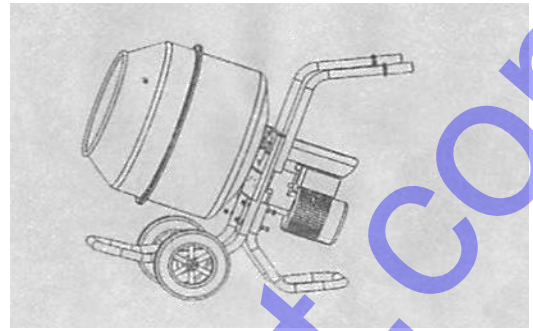

9. Place the upper drum half on the lower half, making sure the mounting holes are clear to install the M6 x 16 mm screws into each mounting hole, secure each screw with elastic washers and hex flange nut.

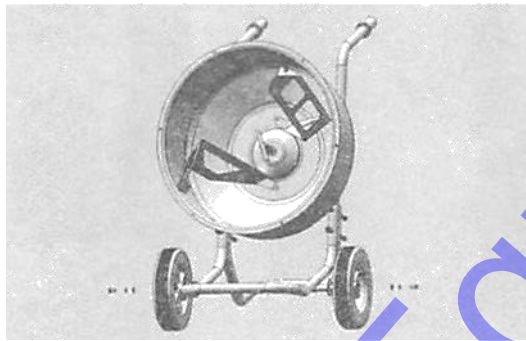

11. Final Product.

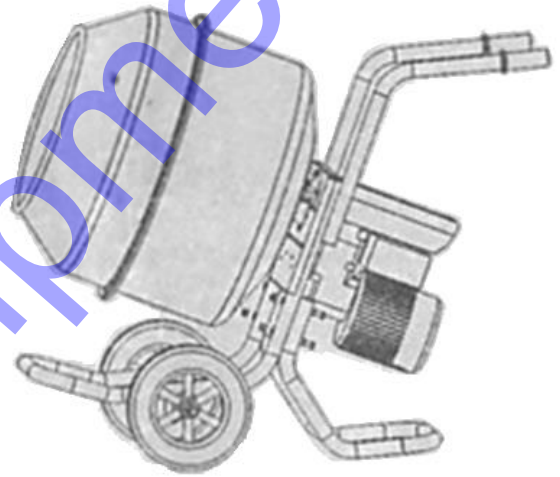

# PARTS BREAKDOWN

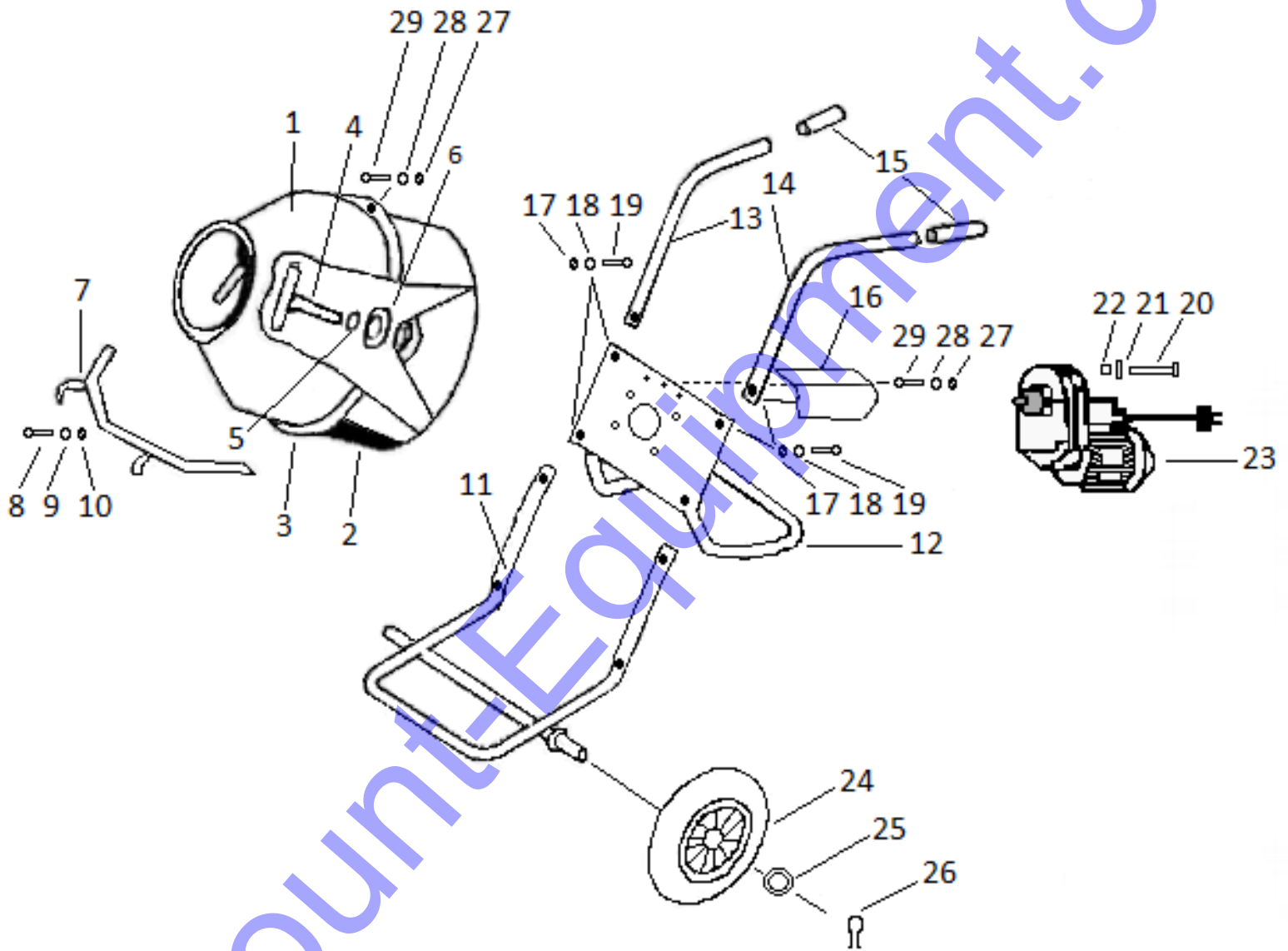

# BOLTS BREAKDOWN

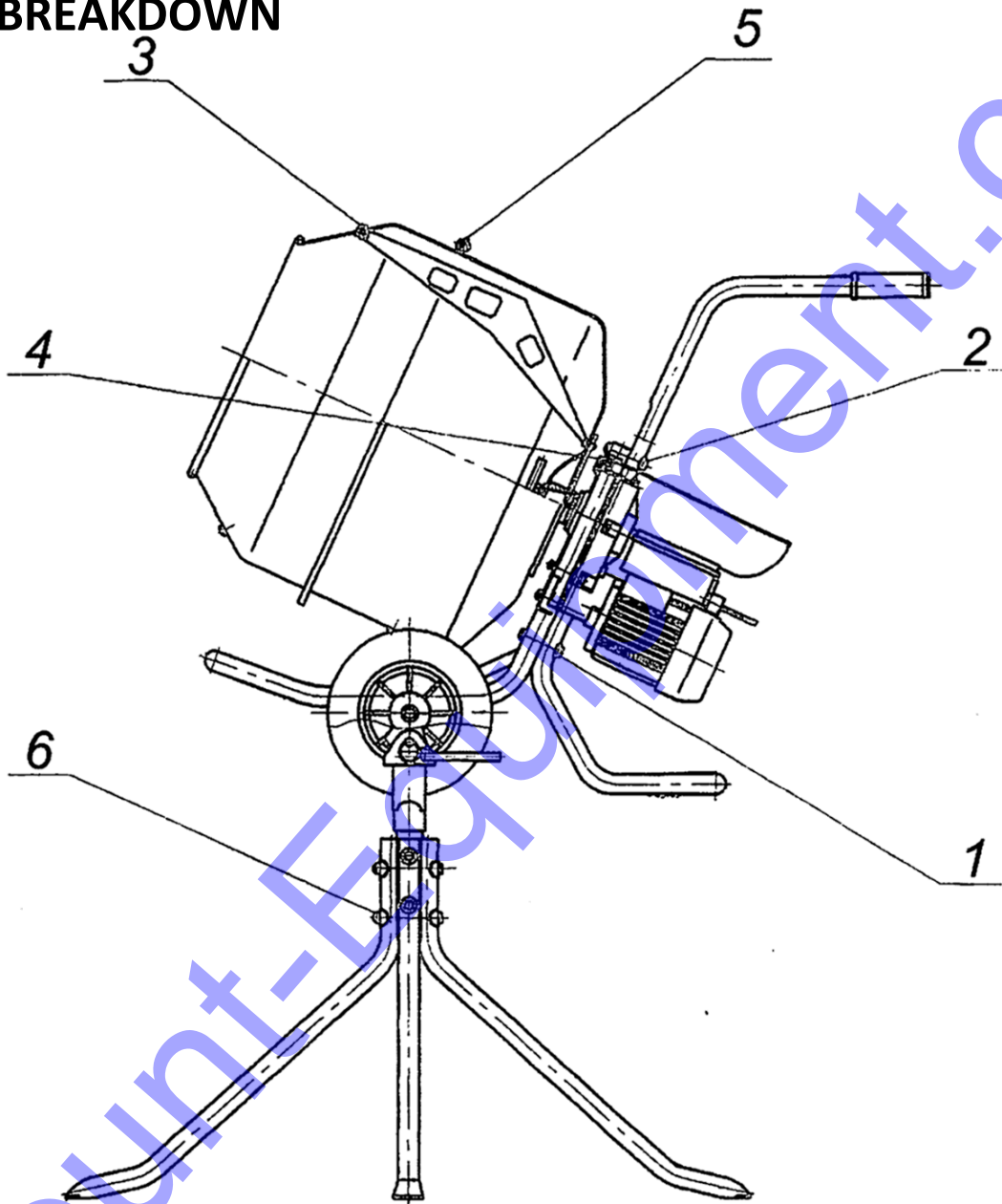



## MAX MIX PARTS LIST

ITEM	PART No.	DESCRIPTION	QTY
1	2250719	MAX MIX UPPER DRUM HALF	1
2	2250720	MAX MIX LOWER DRUM HALF	1
3	N/A	MAX MIX RUBBER GASKET (SEAL)	1
4	2222982	T-BOLT M4 X 35	1
5	N/A	T-BOLT RUBBER WASHER	1
6	2224428	T-BOLT WASHER 14X36X6	1
7	2253145	MIXING PADDLE	2
8	2222193	PADDLE SCREW TB M12X25	4
9	N/A	PADDLE WASHER	4
10	2223700	PADDLE BOLT	4
11	3206159	AXLE FRAME	1
12	N/A	FRAME REAR SUPPORT	1
13	2235450	RIGHT HANDLE	1
14	3206149	LEFT HANDLE	1
15	2288786	HANDLE GRIPS	2
16	N/A	MOTOR COVER	1
17	3206140	FRAME SCREW	4
18	2226700	FRAME WASHER 6	4
19	2226702	FRAME BOLT M6 X 15	4
20	N/A	MOTOR HEX BOLT M6 x 16	4
21	N/A	MOTOR WASHER 6	4
22	N/A	MOTOR SCREW M6	4
23	N/A	MAX MIX MOTOR ASSEMBLY 115V	1
24	2222148	10" WHEEL	2
25	N/A	WHEEL WASHER	2
26	2255749	WHEEL COTTER PIN	2
27	3206365	DRUM AND ENGINE COVER SCREW M8	8
28	3201255	DRUM AND ENGINE COVER WASHER M8	8
29	3206152	DRUM AND ENGINE COVER HEX BOLT M8 X 20	8
30	N/A	MAX MIX PEDESTAL LEG	4
31	N/A	MAX MIX PEDESTAL LEG UNION TUBE	1
32	N/A	PEDESTAL BOLT	4
33	N/A	PEDESTAL WASHER	4
34	N/A	PEDESTAL HEX BOLT	4
35	N/A	PEDESTAL SUPPORT BASE	1
36	N/A	PEDESTAL BASE L BOLT	1
37	N/A	PEDESTAL BASE PIN LOCK	2
38	N/A	PEDESTAL BASE WASHER	2
39	N/A	PEDESTAL BASE HAIR LOCK PIN	2