

**OPERATION AND PARTS MANUAL**



*Mikasa* **SERIES**  
**MODEL MVH408DZ**  
**REVERSIBLE PLATE COMPACTOR**  
**(HATZ 1B50T-9-166 DIESEL ENGINE)**

Revision #2 (08/03/16)



[www.discount-equipment.com](http://www.discount-equipment.com)

**THIS MANUAL MUST ACCOMPANY THE EQUIPMENT AT ALL TIMES.**

# **Discount Equipment**

Discount-Equipment.com is your online resource for commercial and industrial quality parts and equipment sales.

## **Locations:**

Florida (West Palm Beach): [561-964-4949](tel:561-964-4949)

Outside Florida TOLL FREE: [877-690-3101](tel:877-690-3101)

**Need parts?** Check out our website at [www.discount-equipment.com](http://www.discount-equipment.com)

## **Can't find what you need?**



Click on this link: <http://www.discount-equipment.com/category/5443-parts/> and fill out the request form.

Please have the machine model and serial number available in order to help us get you the correct parts. One of our experienced staff members will get back to you with a quote for the right part that your machine needs.

We sell worldwide for the brands: Genie, Terex, JLG, MultiQuip, Mayco, Toro/Stone, Diamond Products, Magnum, Airman, Mustang, Power Blanket, Nifty Lift, Atlas Copco, Chicago Pneumatic, Allmand Brothers, Essick, Miller Spreader, Skyjack, Lull, Skytrak, Tsurumi, Husquyarna/Target, Whiteman-Concrete/Mortar, Stow-Concrete/Mortar, Baldor, Wacker, Sakai, Snorkel, Upright, Mi-T-M, Sullair, Neal, Basic, Dynapac, MBW, Weber, Bartell, Bennar Newman, Haulotte, Ditch Runner, Blaw-Knox, Himoinsa, Best, Buddy, Crown, Edco, Wyco, Bomag, Laymor, Terremite, Barreto, EZ Trench, Takeuchi, Basic, Bil-Jax, Curtis, Gehl, Heli, Honda, ICS/PowerGrit, Puckett, Waldon, ASV, IHI, Partner, Imer, Clipper, MMD, Koshin, Rice, Gorman Rupp, CH&E, Cat Pumps, Comet, General Pump, Giant, AMida, Coleman, NAC, Gradall, Square Shooter, Kent, Stanley, Tamco, Toku, Hatz, Kohler, Robin, Wisconsin, Northrock, Oztec, Toker TK, Rol-Air, Small Line, Wanco, Yanmar

## PROPOSITION 65 WARNING

---

 <b>WARNING</b> 
<b>CALIFORNIA — Proposition 65 Warning</b>
Diesel engine exhaust and some of its constituents are known to the State of California to cause cancer, birth defects and other reproductive harm.

# TABLE OF CONTENTS

## MVH408DZ Reversible Plate Compactor

Proposition 65 Warning .....	2
Table Of Contents .....	4
Parts Ordering Procedures.....	5
Safety Information .....	6-10
Specifications .....	11
Dimensions.....	12
General Information.....	13
Components .....	14-15
Basic Engine.....	16
Inspection .....	17-19
Startup.....	20-21
Operation.....	22-23
Maintenance .....	24-30
Troubleshooting (Compactor) .....	31
Troubleshooting (Engine).....	32-33
Explanation Of Code In Remarks Column.....	34
Suggested Spare Parts .....	35

## Compactor Component Drawings

Vibrating Plate Assembly.....	36-37
Vibrator Assembly .....	38-39
Base And Engine Assembly .....	40-43
Electric Device Assembly .....	44-47
Control Assembly .....	48-51
Nameplate And Decals Assembly .....	52-53

## Hatz 1B50 Engine Component Drawings

Spare Parts Kit Assembly.....	54-55
Accessories Assembly.....	56-57
Crankcase Assembly.....	58-59
Crankshaft Assembly.....	60-61
Camshaft Assembly.....	62-63
Piston, Connecting Rod, Cylinder Assembly.....	64-65
Cylinder Head Assembly .....	66-67
Oil Pump, Governor Assembly .....	68-69
Timing Cover Assembly.....	70-71
Blower, Flywheel Assembly .....	74-75
Injection Equipment Assembly .....	76-79
Recoil Starter Assembly .....	80-81
Air Ducting A Assembly .....	82-83
Air Ducting B Assembly .....	84-85
Crankcase Breathing System Assembly .....	86-87
Fuel Assembly .....	88-89
Air Filter Assembly.....	90-91
Exhaust Silencer Assembly .....	92-93
Starter, Alternator Assembly.....	94-97
Electric Equipment, Wirings Assembly .....	98-99
Speed Control Assembly .....	100-101
Spec. Equipment EPA Assy. ....	102-103

Terms And Conditions Of Sale — Parts .....	104
--	-----

### NOTICE

Specifications and part numbers are subject to change without notice.

# SAFETY INFORMATION

Do not operate or service the equipment before reading the entire manual. Safety precautions should be followed at all times when operating this equipment. Failure to read and understand the safety messages and operating instructions could result in injury to yourself and others.



## SAFETY MESSAGES

The four safety messages shown below will inform you about potential hazards that could injure you or others. The safety messages specifically address the level of exposure to the operator and are preceded by one of four words: **DANGER**, **WARNING**, **CAUTION** or **NOTICE**.

## SAFETY SYMBOLS

**! DANGER**

Indicates a hazardous situation which, if not avoided, **WILL** result in **DEATH** or **SERIOUS INJURY**.

**! WARNING**

Indicates a hazardous situation which, if not avoided, **COULD** result in **DEATH** or **SERIOUS INJURY**.







**! CAUTION**

Indicates a hazardous situation which, if not avoided, **COULD** result in **MINOR** or **MODERATE INJURY**.

**NOTICE**

Addresses practices not related to personal injury.

Potential hazards associated with the operation of this equipment will be referenced with hazard symbols which may appear throughout this manual in conjunction with safety messages.

Symbol	Safety Hazard
	Lethal exhaust gas hazards
	Explosive fuel hazards
	Burn hazards
	Respiratory hazards
	Accidental starting hazards
	Eye and hearing hazards
	Rotating parts hazards

# SAFETY INFORMATION

## GENERAL SAFETY

### CAUTION

- **NEVER** operate this equipment without proper protective clothing, shatterproof glasses, respiratory protection, hearing protection, steel-toed boots and other protective devices required by the job or city and state regulations.



- **NEVER** operate this equipment when not feeling well due to fatigue, illness or when under medication.



- **NEVER** operate this equipment under the influence of drugs or alcohol.



- **ALWAYS** check the equipment for loosened threads or bolts before starting.
- **DO NOT** use the equipment for any purpose other than its intended purposes or applications.
- **ALWAYS** clear the work area of any debris, tools, etc. that would constitute a hazard while the equipment is in operation.

### NOTICE

- This equipment should only be operated by trained and qualified personnel 18 years of age and older.
- Whenever necessary, replace nameplate, operation and safety decals when they become difficult read.
- Manufacturer does not assume responsibility for any accident due to equipment modifications. Unauthorized equipment modification will void all warranties.
- **NEVER** use accessories or attachments that are not recommended by Multiquip for this equipment. Damage to the equipment and/or injury to user may result.
- **ALWAYS** know the location of the nearest **fire extinguisher**.
- **ALWAYS** know the location of the nearest **first aid kit**.
- **ALWAYS** know the location of the nearest phone or **keep a phone on the job site**. Also, know the phone numbers of the nearest **ambulance, doctor and fire department**. This information will be invaluable in the case of an emergency.

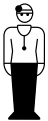

# SAFETY INFORMATION

## COMPACTOR SAFETY

### DANGER

- **NEVER** operate the equipment in an explosive atmosphere or near combustible materials. An explosion or fire could result causing severe **bodily harm or even death.**



### WARNING

- **NEVER** disconnect any **emergency or safety devices.** These devices are intended for operator safety. Disconnection of these devices can cause severe injury, bodily harm or even death. Disconnection of any of these devices will void all warranties.

### CAUTION

- **NEVER** lubricate components or attempt service on a running machine.

### NOTICE

- **ALWAYS** keep the machine in proper running condition.
- Fix damage to machine and replace any broken parts immediately.
- **ALWAYS** store equipment properly when it is not being used. Equipment should be stored in a clean, dry location out of the reach of children and unauthorized personnel.

## ENGINE SAFETY

### DANGER

- The engine fuel exhaust gases contain poisonous carbon monoxide. This gas is colorless and odorless, and can cause death if inhaled.
- The engine of this equipment requires an adequate free flow of cooling air. **NEVER** operate this equipment in any enclosed or narrow area where free flow of the air is restricted. If the air flow is restricted it will cause injury to people and property and serious damage to the equipment or engine.



### WARNING

- **DO NOT** place hands or fingers inside engine compartment when engine is running.
- **NEVER** operate the engine with heat shields or guards removed.
- Keep fingers, hands hair and clothing away from all moving parts to prevent injury.
- **DO NOT** remove the radiator cap while the engine is hot. High pressure boiling water will gush out of the radiator and severely scald any persons in the general area of the compactor.
- **DO NOT** remove the coolant drain plug while the engine is hot. Hot coolant will gush out of the coolant tank and severely scald any persons in the general area of the compactor.
- **DO NOT** remove the engine oil drain plug while the engine is hot. Hot oil will gush out of the oil tank and severely scald any persons in the general area of the compactor.



### CAUTION

- **NEVER** touch the hot exhaust manifold, muffler or cylinder. Allow these parts to cool before servicing equipment.



### NOTICE

- **NEVER** run engine without an air filter or with a dirty air filter. Severe engine damage may occur. Service air filter frequently to prevent engine malfunction.
- **NEVER** tamper with the factory settings of the engine or engine governor. Damage to the engine or equipment can result if operating in speed ranges above the maximum allowable.
- **NEVER** tip the engine to extreme angles during lifting as it may cause oil to gravitate into the cylinder head, making the engine start difficult.



# SAFETY INFORMATION

## FUEL SAFETY

### DANGER

- **DO NOT** add fuel to equipment if it is placed inside truck bed with plastic liner. Possibility exists of explosion or fire due to static electricity.

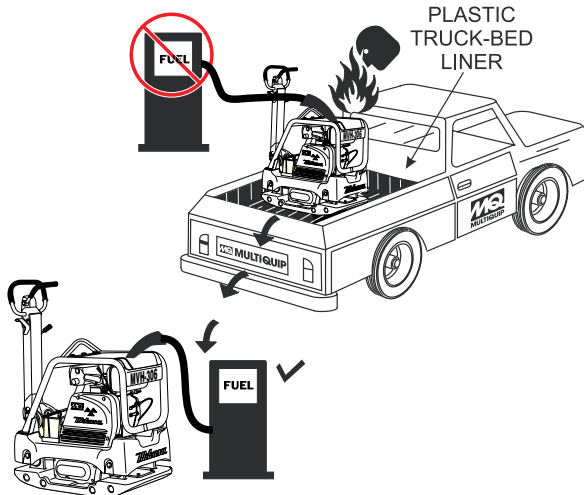

- **DO NOT** start the engine near spilled fuel or combustible fluids. Diesel fuel is extremely flammable and its vapors can cause an explosion if ignited.
- **ALWAYS** refuel in a well-ventilated area, away from sparks and open flames.
- **ALWAYS** use extreme caution when working with **flammable** liquids.
- **DO NOT** fill the fuel tank while the engine is running or hot.
- **DO NOT** overfill tank, since spilled fuel could ignite if it comes into contact with hot engine parts or sparks from the ignition system.
- Store fuel in appropriate containers, in well-ventilated areas and away from sparks and flames.
- **NEVER** use fuel as a cleaning agent.
- **DO NOT** smoke around or near the equipment. Fire or explosion could result from fuel vapors or if fuel is spilled on a hot engine.



## BATTERY SAFETY (ELECTRIC START ONLY)

### DANGER

- **DO NOT** drop the battery. There is a possibility that the battery will explode.
- **DO NOT** expose the battery to open flames, sparks, cigarettes, etc. The battery contains combustible gases and liquids. If these gases and liquids come into contact with a flame or spark, an explosion could occur.



### WARNING

- **ALWAYS** wear safety glasses when handling the battery to avoid eye irritation. The battery contains acids that can cause injury to the eyes and skin.
- Use well-insulated gloves when picking up the battery.
- **ALWAYS** keep the battery charged. If the battery is not charged, combustible gas will build up.
- **DO NOT** charge battery if frozen. Battery can explode. When frozen, warm the battery to at least 61°F (16°C).
- **ALWAYS** recharge the battery in a well-ventilated environment to avoid the risk of a dangerous concentration of combustible gases.
- If the battery liquid (dilute sulfuric acid) comes into contact with **clothing or skin**, rinse skin or clothing immediately with plenty of water.
- If the battery liquid (dilute sulfuric acid) comes into contact with **eyes**, rinse eyes immediately with plenty of water and contact the nearest doctor or hospital to seek medical attention.



### CAUTION

- **ALWAYS** disconnect the **NEGATIVE** battery terminal before performing service on the equipment.
- **ALWAYS** keep battery cables in good working condition. Repair or replace all worn cables.



# SAFETY INFORMATION

## TRANSPORTING SAFETY

### CAUTION

- NEVER allow any person or animal to stand underneath the equipment while lifting.

### NOTICE

- Before lifting, make sure that the equipment parts (hook and vibration insulator) are not damaged and screws are not loose or missing.
- Always make sure crane or lifting device has been properly secured to the lifting bail (hook) of the equipment.
- ALWAYS shutdown engine before transporting.
- NEVER lift the equipment while the engine is running.
- Tighten fuel tank cap securely and close fuel cock to prevent fuel from spilling.
- Use adequate lifting cable (wire or rope) of sufficient strength.
- Use one point suspension hook and lift straight upwards.
- DO NOT lift machine to unnecessary heights.
- ALWAYS tie down equipment during transport by securing the equipment with rope.

## ENVIRONMENTAL SAFETY/DECOMMISSIONING

### NOTICE

Decommissioning is a controlled process used to safely retire a piece of equipment that is no longer serviceable. If the equipment poses an unacceptable and unrepairable safety risk due to wear or damage or is no longer cost effective to maintain (beyond life-cycle reliability) and is to be decommissioned (demolition and dismantlement), be sure to follow rules below:

- DO NOT pour waste or oil directly onto the ground, down a drain or into any water source.
- Contact your country's Department of Public Works or recycling agency in your area and arrange for proper disposal of any electrical components, waste or oil associated with this equipment.



- When the life cycle of this equipment is over, remove battery and bring to appropriate facility for lead reclamation. Use safety precautions when handling batteries that contain sulfuric acid.

- When the life cycle of this equipment is over, it is recommended that the trowel frame and all other metal parts be sent to a recycling center.

Metal recycling involves the collection of metal from discarded products and its transformation into raw materials to use in manufacturing a new product.

Recyclers and manufacturers alike promote the process of recycling metal. Using a metal recycling center promotes energy cost savings.

## EMISSIONS INFORMATION

### NOTICE

The diesel engine used in this equipment has been designed to reduce harmful levels of carbon monoxide (CO), hydrocarbons (HC) and nitrogen oxides (NOx) contained in diesel exhaust emissions.

This engine has been certified to meet US EPA Evaporative emissions requirements in the installed configuration.

Attempting to modify or make adjustments to the engine emission system by unauthorized personnel without proper training could damage the equipment or create an unsafe condition.

Additionally, modifying the fuel system may adversely affect evaporative emissions, resulting in fines or other penalties.

### Emission Control Label

The emission control label is an integral part of the emission system and is strictly controlled by regulations.

The label must remain with the engine for its entire life.

If a replacement emission label is needed, please contact your authorized Kohler Engine Distributor.

## SPECIFICATIONS

Table 1. MVH408DZ Specifications	
Centrifugal Force	12,365 lbf (55 kN)
Vibration Frequency	4,400 vpm (73 Hz)
Maximum Traveling Speed	79 ft/min (24 m/min)
Plate Size (W x L)	19.68 x 35.43 in (500 x 900 mm)
Plate Size (W x L) with extension plates	25.59 x 35.43 in (650 x 900 mm)
Max. Forward Speed	82 ft./min (25 m/min)
Recommended Battery Types	Centennial 25-75, Interstate MT85, North Star NSB-AGM35, Odyssey PC1400/35
Battery Dimensions (LxWxH)	9.75 x 7 x 9 in. (248 x 178 x 229 mm)
Operating Weight	899.48 lbs. (408 kg.)
Operating Weight with extension plates	932.55 lbs. (423 kg.)

Table 2. Engine Specifications	
Engine Make	HATZ
Engine Model	1B50T-9-166
Engine Type	Air-cooled, 4 Cycle Diesel Engine
Cylinder Bore X Stroke	3.66 in. x 2.99 in. (93 mm x 76 mm)
Displacement	31.55 cu-in (517 cc)
Maximum Output	9 BHP (6.7 kW) @ 2500 RPM
Fuel Tank Capacity	Approx. 1.4 U.S. gallons (5.3 liters)
Fuel Type	Diesel
Oil Capacity	1.58 qts (1.5 liters)
Starting Method	Recoil/Electric Start
Dry Net Weight	123.46 lbs (56 Kg.)

# DIMENSIONS

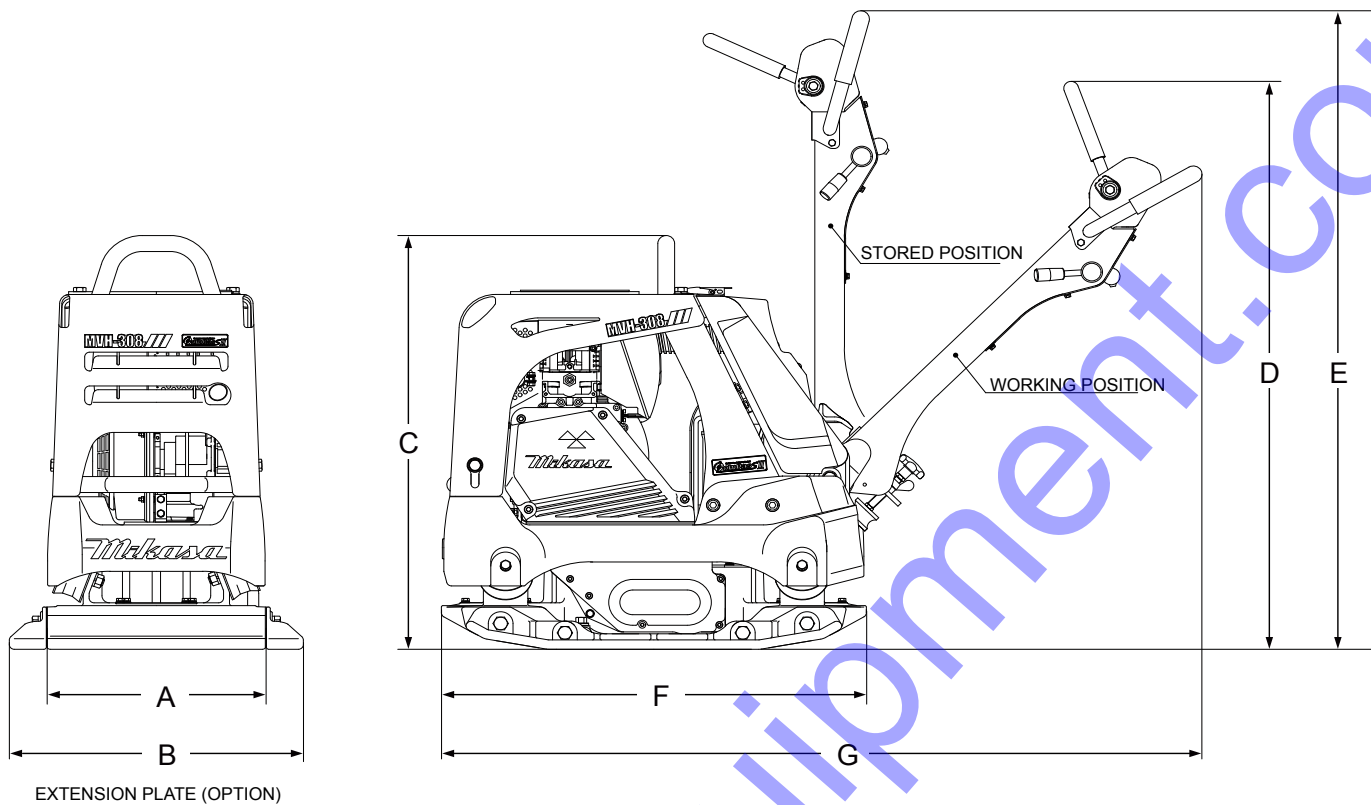

Figure 1. Dimensions

Table 3. Dimensions	
REF. DES	IN. (MM)
A	19.68 (500)
B	25.59 (650)
C	36.61 (930)
D	47.64 (1210)
E	53.54 (1360)
F	35.43 (900)
G	62.01 (1575)

## GENERAL INFORMATION

### DEFINITION OF PLATE COMPACTOR

The Mikasa MVH408DZ is a reversible plate compactor designed for efficient compaction of sand, gravel and cohesive soils. This plate compactor is a powerful compacting tool capable of applying a tremendous force in consecutive high frequency vibrations to a soil surface. Its applications include compacting for road, embankments and reservoirs as well as backfilling for gas pipelines, water pipelines and cable installation work.

### VIBRATORY PLATES

The vibratory plates of the compactor produce low amplitude high frequency vibrations, designed to compact granular soils and asphalt.

The resulting vibrations cause forward motion. The engine and handle are vibration isolated from the vibrating plate.

### FREQUENCY/SPEED

The compactor's vibrating plate produces a vibration frequency of 4,400 VPM (vibrations per minute). The travel speed of the compactor is approximately 82 ft/minute (25 meters/minute).

### ENGINE

This plate compactor are equipped with a Hatz 1B50 air cooled, 4-cycle diesel engine. The engine drives an eccentric weight at a high speed to develop a compaction force.

#### NOTICE

The MVH408DZ plate compactor is shipped from the factory **without the battery**. Battery can be purchased locally. Reference Table 1 for battery specifications.

### CONTROLS

Before starting the plate compactor identify and understand the function of all the controls and components.

# COMPONENTS

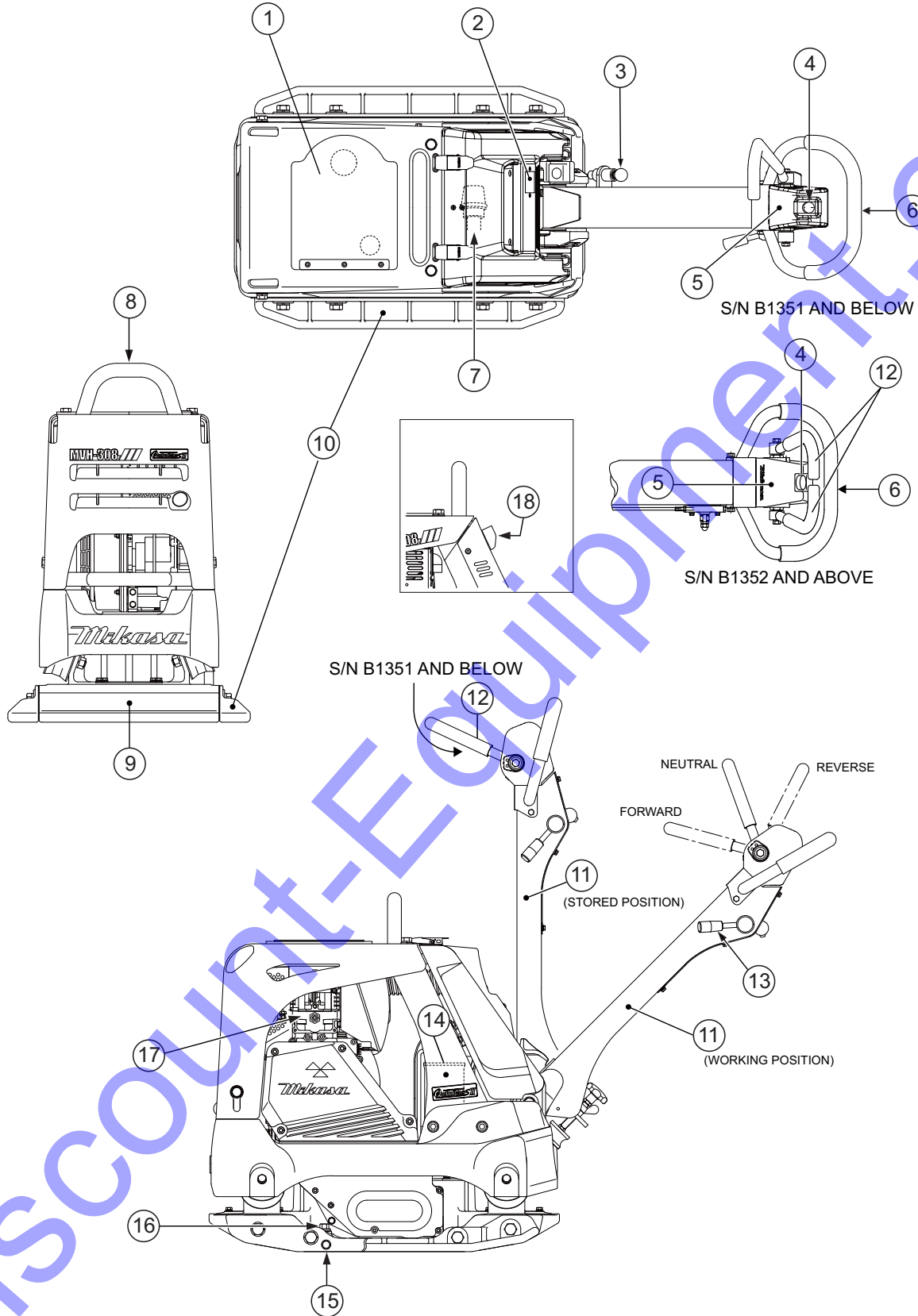
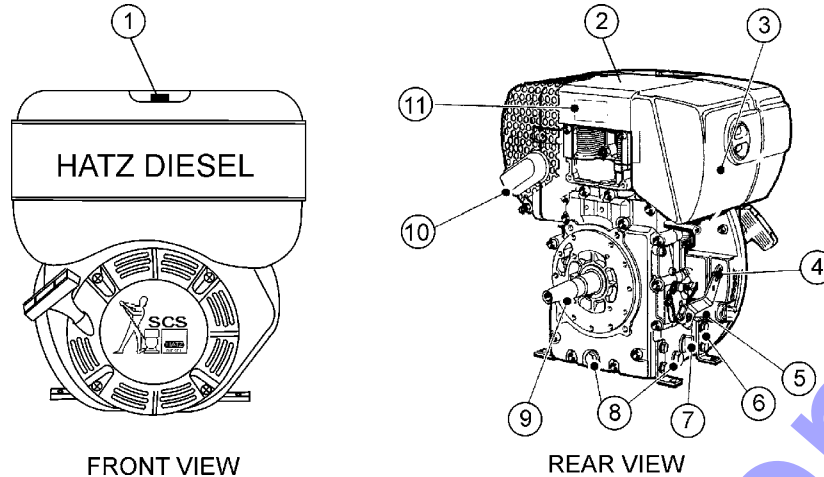

Figure 2. Plate Compactor Components

## COMPONENTS

Figure 2 shows the location of the basic controls and components of the MVH408DZ Plate Compactor. The function of each control is described below:

1. **Rubber Cover** — Lift this rubber cover to gain access to the fuel tank.
2. **Hour/Tachometer** — Displays the cumulative time that the machine has been in use. During operation it displays the rpm reading. The tachometer also has a battery checker that lights red when the charge is low.
3. **Handle Bar Height Adjuster** — Adjusts the handle bar to the desired height by loosening the wing nut and turning the grip clockwise to raise the handle bar and counterclockwise to lower the handle bar.
4. **Breather Plug** — Allow pressure to escape to the air in the form of a gas from heat.
5. **Hydraulic Pump (Oil Reservoir)** — Regulates hydraulic oil flow produced by the direction of the control lever.
6. **Hand Grip** — When operating the compactor use this hand grip to maneuver the compactor.
7. **Cyclone Cleaner** — Filters large dust particles to keep air cleaner from getting clogged easily.
8. **Lifting Bale** — When lifting of the compactor is required either by forklift, crane etc., tie rope or chain around this lifting point.
9. **Vibrating Plate** — A flat, open plate made of durable cast iron construction used in the compacting of soil.
10. **Extension Plate** — Provides additional area of vibration to the vibrating plate.
11. **Handle Bar** — When operating the compactor, this handle is to be in the downward position. When the compactor is to be **stored**, move the handle bar to the upright position.
12. **Direction Control Lever** — *Push* the lever forward to move compactor in a forward direction. *Pull* the lever backwards to move compactor in backwards direction. Placing the lever in the middle (midway) will cause the compactor not to move (neutral).
13. **Throttle Lever** — Controls speed of the plate compactor. Place straight vertically to start, **push** fully counterclockwise for full throttle and fully clockwise to stop plate compactor.
14. **Battery** — Provides +12V DC to the electrical system.
15. **Vibrator Oil Drain Plug** — Used to drain vibrator oil from the machine.
16. **Vibration Case Oil Filler** — Used to add oil to the vibration case.
17. **Engine** — This plate compactor uses a Hatz 1B50 diesel engine. Refer to the owner's manual for engine information.
18. **Engine ON/OFF Switch** — Used to turn the engine on or off.



**Figure 3. Engine Controls and Components**

## INITIAL SERVICING

The engine (Figure 3) must be checked for proper lubrication and filled with fuel prior to operation. Refer to the manufacturer's Engine manual for operating and servicing information.

1. **Fuel Filler Cap/Fuel Tank** — Pull this latch to add *diesel* fuel to the tank. After refueling, always make sure the fuel cap is latched properly. **DO NOT** over fill. For additional information refer to engine owner's manual.

### DANGER



Adding fuel to the tank should be done only when the engine is stopped and has had an opportunity to cool down. In the event of a fuel spill, **DO NOT** attempt to start the engine until the fuel residue has been completely wiped up, and the area surrounding the engine is dry.

2. **Engine Lifting Straps/Cover** — Remove the air cleaner cover, then lift this cover (the one with decals on it) to gain access to the engine lifting straps.
3. **Air Cleaner/Cover** — Prevents dirt and other debris from entering the fuel system. Remove wing-nut on side of air filter cover to gain access to filter element.
4. **Speed Control Lever** — This lever is connected to the throttle control which is located on the side of the engine compartment cover. Use this lever to control engine speed.
5. **Dipstick** — Remove dipstick to determine if the engine oil level is low. If low, add oil as specified.

6. **Engine Motor Mounts** — Attach these engine mounts to the pump frame. Tighten securely.
7. **Oil Filter** — Remove this bolt to gain access (internal) to the engine oil filter. Service the oil filter as recommended in the maintenance section of this manual.
8. **Oil Drain Plugs** — There are two oil drain plugs, one is underneath the flywheel, the other on the side of the engine. Remove these plugs to drain engine oil from the engine crankcase.
9. **Crankshaft** — Connect this shaft to the input of the transmission.
10. **Muffler** — Used to reduce noise and emissions.
11. **Nameplate** — Contains information about the engine.

### NOTICE

Operating the engine without an air filter, with a damaged air filter, or a filter in need of replacement will allow dirt to enter the engine, causing rapid engine wear.

### WARNING



Engine components can generate extreme heat. To prevent burns, **DO NOT** touch these areas while the engine is running or immediately after operating. **NEVER** operate the engine with the muffler removed.

## BEFORE STARTING

1. Read all safety instructions at the beginning of manual.
2. Clean the compactor, removing dirt and dust, particularly the engine cooling air inlet, carburetor and air cleaner.
3. Check the air filter for dirt and dust. If air filter is dirty, replace air filter with a new one as required.
4. Check carburetor for external dirt and dust. Clean with dry compressed air.
5. Check fastening nuts and bolts for tightness.

## ENGINE OIL CHECK

1. To check the engine oil level, place the compactor on secure level ground with the engine stopped. If the oil level is low, add oil (Grade CC or above).
2. Lubrication is done from the top of the engine (Figure 4).

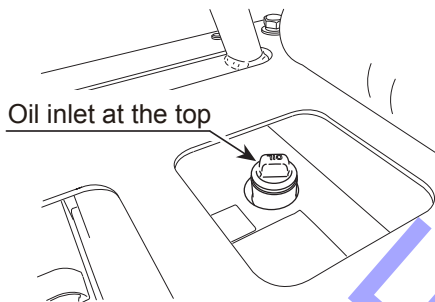

Figure 4. Adding Engine Oil

### NOTICE

Pour oil slowly from the top. Oil might overflow if large amount of oil is poured right away.

Table 4. Oil Type

Season	Temperature	Oil Type
Summer	25°C or Higher	SAE 10W-30
Spring/Fall	25°C~10°C	SAE 10W-30/20
Winter	0°C or Lower	SAE 10W-10

### DANGER



#### EXPLOSIVE FUEL!

Motor fuels are highly flammable and can be dangerous if mishandled. **DO NOT** smoke while refueling. **DO NOT** attempt to refuel the compactor if the engine is hot or running.

## FUEL CHECK

1. The fuel tank cap is equipped with a lock lever. Unlock the lever before opening cap (Figure 5).

Lock lever      Fuel tank cap

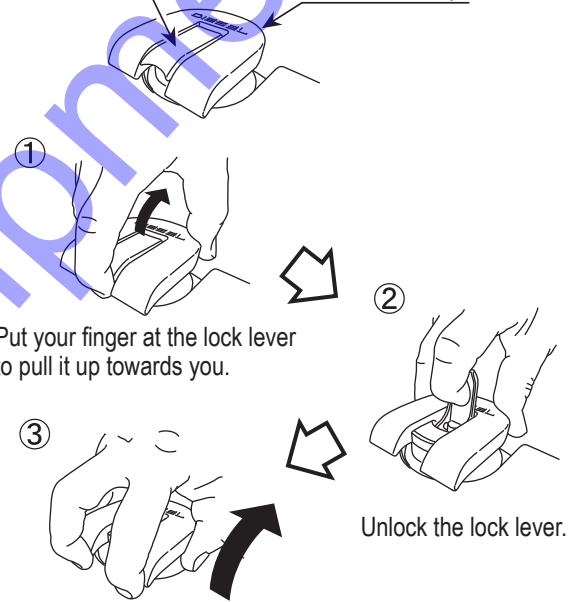

Put your finger at the lock lever to pull it up towards you.

Put your fingers to the tabs at the two locations of the tank cap to pull up towards you.

Unlock the lock lever.

Figure 5. Unlocking Fuel Cap Lever

1. Visually inspect to see if fuel level is low. If fuel is low, replenish with unleaded fuel. Fuel inlet is located under the rubber cover at the front cover top portion.
2. When refueling, be sure to use a strainer for filtration. **DO NOT** top-off fuel. Wipe up any spilled fuel immediately.



## V-BELT COVER REMOVAL

To inspect the V-belt, remove the three bolts that secure the belt cover to the frame as shown in Figure 6.

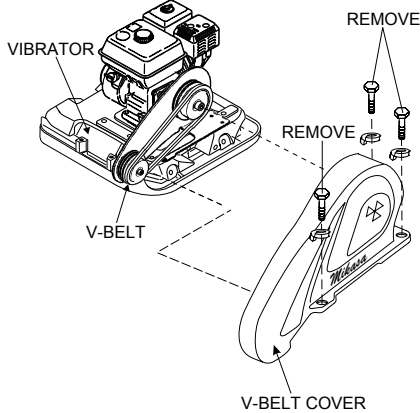

Figure 6. V-Belt Cover Removal

## V-BELT INSPECTION

Visually examine the V-belt (Figure 7) and determine if it is full of tiny cracks, frayed, has pieces of rubber missing, is peeling or otherwise damaged.

Also, examine the belt and determine if it is **oil soaked** or **"glazed"** (hard shiny appearance on the sides of the belt). Either of these two conditions can cause the belt to run hot, which can weaken it and increase the danger of it breaking.

If the V-belt exhibits any of the referenced wear conditions replace the V-belt immediately

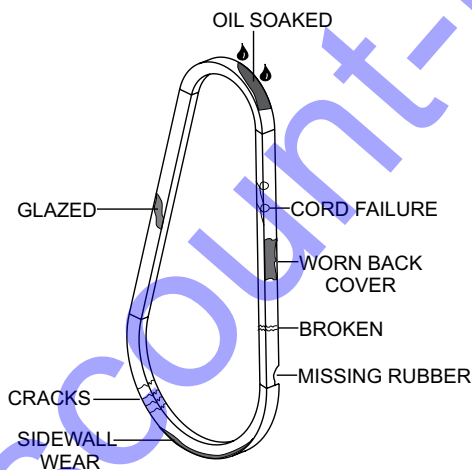

Figure 7. Drive Belt Inspection

## V-BELT TENSION

The V-belt tension is proper if the V-belt bends 10 to 15 mm (Figure 8) when depressed with finger at midway between the clutch and vibrator pulleys.

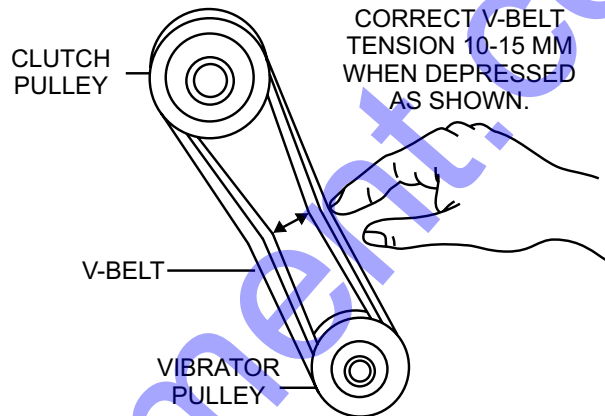

Figure 8. V-Belt Tension

## VIBRATOR OIL CHECK

1. Place the plate compactor horizontally on a flat surface. Make sure the compactor is level when checking the oil in the vibrator assembly.
2. Check vibrator oil level by removing the oil plug (vibrator oil gauge) as shown in Figure 9. Clean the oil gauge and re-thread back in. Remove the oil gauge again and confirm oil level does not exceed the cross hash of the oil plug. **DO NOT OVERFILL!**
3. The vibrator holds approximately 20.3 oz. (600 cc). **IMPORTANT**, if oil is required, replace using only SAE 10W-30 motor oil.

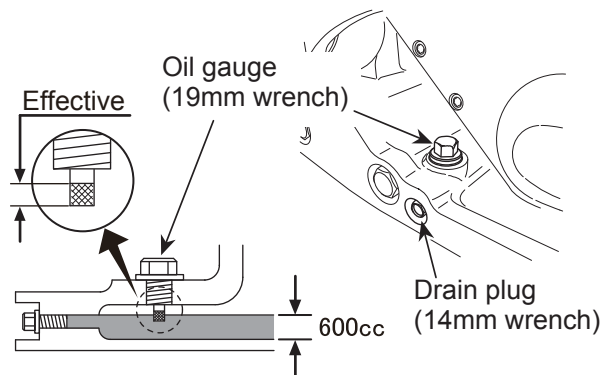
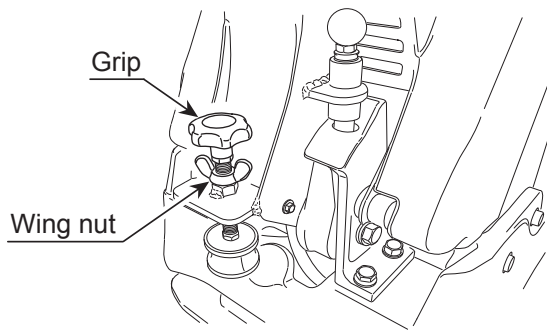

Figure 9. Vibrator Oil Check

**HANDLE BAR**

The height of the handle bar can be adjusted for ease of use. Adjust the handle height as follows. Refer to Figure 10.

1. Loosen the wing nut.
2. Turn the grip clockwise to raise the handle or counterclockwise to lower the handle.
3. When the handle bar is raised to the desired height, tighten the wing nut.



**Figure 10. Handle Height Adjustment**

**CAUTION**



**DO NOT** attempt to operate the compactor until the Safety, General Information and Inspection sections of this manual have been *read and thoroughly understood*.

This section is intended to assist the operator with the initial startup of the compactor. It is extremely important that this section be read carefully before attempting to use the compactor in the field.

## STARTING THE ENGINE

### Electric Start

1. Insert the key to the key switch.
2. Move the throttle lever (Figure 11) to the **idle** position.

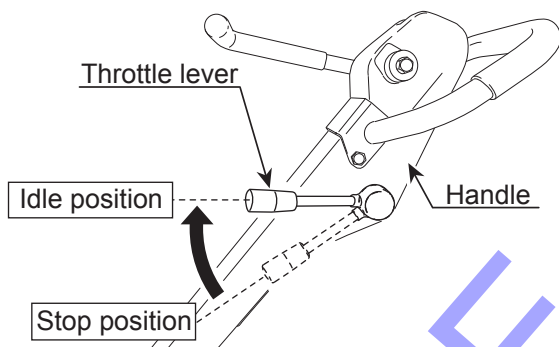

**Figure 11. Throttle Lever (Idle Position)**

3. Turn the key to the "Run" position (Figure 12). The buzzer sounds.

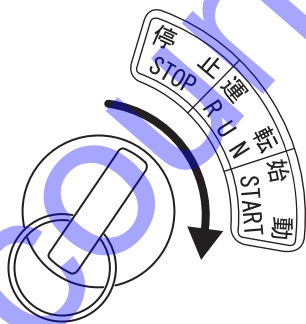

**Figure 12. Key Positions**

4. After "HA" is displayed on the hour tachometer, the display will change immediately to "cumulative time" (Figure 13).

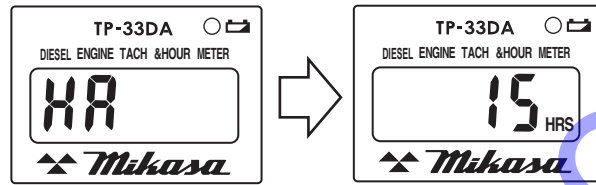

"HA" is displayed at the operation position, then immediately it will change to "Cumulative time".

**Figure 13. Hour Tachometer (Cumulative Time)**

5. Turn the key further to the "Start" position to start the engine. When the engine starts, let go of the key. When the engine revolution increases, the buzzer stops.
6. When the engine is in operation, the Hour Tachometer display will show the "rotation number" (Figure 14).

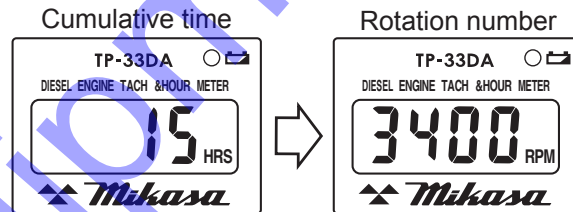

**Figure 14. Hour Tachometer (Rotation Number)**

7. After the engine has started, warm up the engine at low speed for 2 to 3 minutes, especially in cold weather.

**CAUTION**

When the engine does not start, do not run the cell motor continuously for more than 5 seconds. Move the key back to the "Run" position then wait about 10 seconds to restart.

While the engine is running, never turn the key switch to the "Start" position.

## Recoil Start

1. Insert the key to the key switch.
2. Move the throttle lever (Figure 11) to the *idle* position.
3. Turn the key to the "Run" position (Figure 12). The buzzer sounds.
4. After "HA" is displayed on the hour tachometer, the display will change immediately to "cumulative time"
5. Grasp the starter grip (Figure 15) and slowly pull it out. The resistance becomes the hardest at a certain position, corresponding the compression point. Rewind the rope a little from that point and pull out sharply.

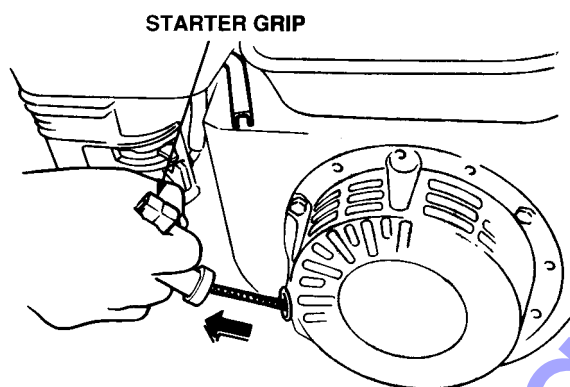

Figure 15. Starter Grip

### NOTICE

**DO NOT** pull the starter rope all the way to the end.

**DO NOT** release the starter rope after pulling. Allow it to rewind as slow as possible.

6. When engine starts, release the starter grip and allow the rope to recoil.
7. After the engine has started, warm up the engine at low speed for 2 to 3 minutes, especially in cold weather.
8. Before the compactor is placed in to operation, run the engine for several minutes. Check for fuel leaks, and noises that would associate with a loose component.

## OPERATION

### CAUTION



**ALWAYS** follow all safety rules in the safety section of this manual before operating compactor. Keep work area clear of debris and other objects that could cause bodily injury or damage to the compactor.

1. Once the engine has started, move the engine throttle lever quickly to the **operation** position (Figure 16).

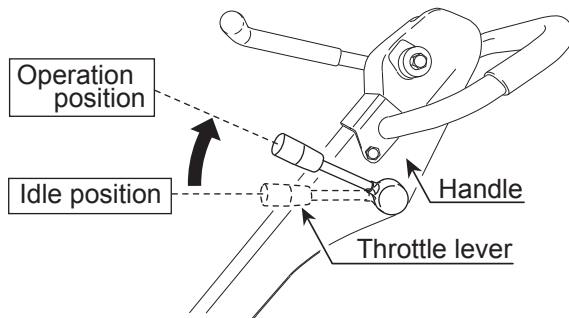

**Figure 16. Throttle Lever (Operation Position)**

2. With the throttle lever in the run position, the engine speed should be around 2,300 RPM, therefore engaging the centrifugal clutch.

### NOTICE

**ALWAYS** move the throttle lever quickly without hesitation, because increasing the engine speed slowly causes the clutch to slip.

3. The direction control lever allows the machine to be moved either backward or forward (Figure 17). When the direction control lever is pushed forward, the machine moves forward. When pulled backward, the machine moves backward.

### NOTICE

Your unit may be equipped with direction control levers on both the right and left side of the handle. Earlier models only have one control lever located on the right side of the handle.

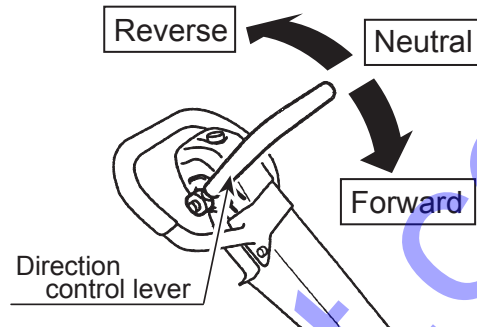

**Figure 17. Direction Control Lever**

4. When the direction control lever is in the neutral position, the machine vibrates staying at the same location

### NOTICE

**NEVER** stop the engine suddenly while working at high speeds.

5. Compactor traveling speed may drop on soils which contain clay, however there may be cases where traveling speed drops because the compaction plate does not leave the ground surface easily due to the composition of the soil. To rectify this problem do the following:
  - Check the bottom plate to see if clay or equivalent material has been lodge in the plate mechanism. If so, wash with water and remove.
  - Remember the compactor does not work as efficiently on clay or soils that have a high moisture content level.
  - If the soil has a high moisture level, dry soil to appropriate moisture content level or carry out compaction twice.

## STOPPING THE ENGINE

### Normal Shutdown

1. Move the throttle lever to the *idle* position (Figure 18) and run the engine for three minutes at low speed.

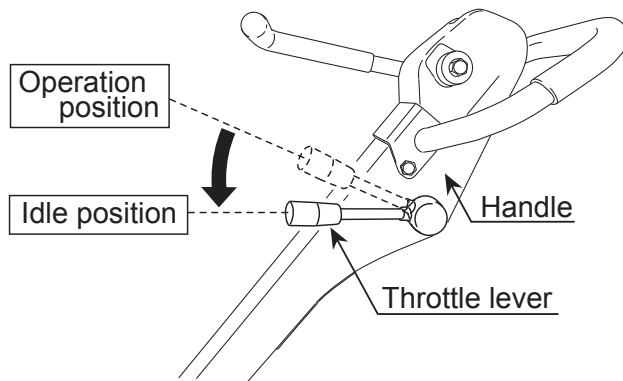

Figure 18. Throttle Lever (Idle)

2. Move the throttle lever (Figure 19) to the "Stop" position to stop the engine. The buzzer will sound.

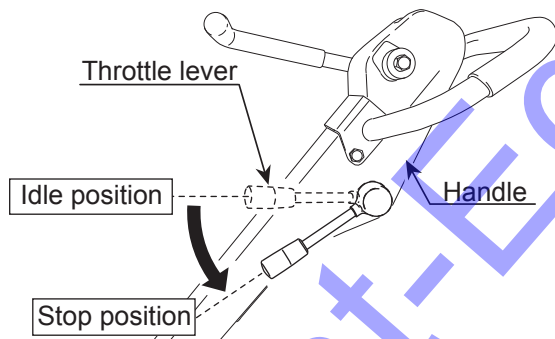

Figure 19. Throttle Lever (Stop Position)

3. Turn the key to the "Stop" position (Figure 20). The buzzer will stop.

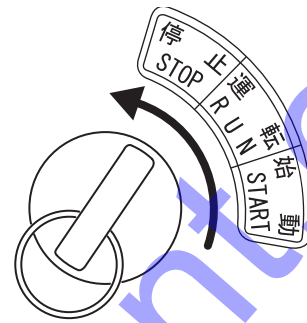

Figure 20. Key Switch (Stop)

### Emergency Shutdown

1. Move the throttle lever quickly to the **IDLE** position, and turn the key to the "Stop" position.

## GENERAL MAINTENANCE

General maintenance practices are crucial to the performance and longevity of your compactor. This equipment requires routine cleaning, inspection and lubrication. Refer to Table 5 and Table 6 for scheduled engine and compactor maintenance.

The following procedures, devoted to maintenance, can prevent serious compactor damage or malfunctioning.

### NOTICE

Refer to **HATZ** engine manual supplied with your compactor for more detailed engine maintenance and troubleshooting.

### CAUTION



**ALWAYS** allow the engine to cool before servicing. **NEVER** attempt any maintenance work on a hot engine.

### WARNING



Some maintenance procedures may require the engine to be run. Ensure that the maintenance area is well ventilated. Diesel engine exhaust contains poisonous carbon monoxide gas that can cause unconsciousness and may result in **DEATH**.

## General Cleanliness

Clean the compactor daily. Remove all dust and debris buildup (mud, clay etc.). If the compactor is steam-cleaned, ensure that lubrication is accomplished **AFTER** steam cleaning.

### NOTICE

Inspection and other services should always be carried out on hard and level ground with the engine shut down.

### NOTICE

The inspection intervals listed in the maintenance tables are for operation under normal conditions. Adjust your inspection intervals based on the number hours plate compactor is in use, and particular working conditions.

# MAINTENANCE

To make sure your plate compactor is always in good working condition before using, carry out the maintenance inspection in accordance with Table 5 and Table 6.

## ENGINE MAINTENANCE

Perform engine maintenance as listed in Table 5.

Table 5. Engine Maintenance Schedule								
Description (3)	Operation	Before	First Month or 10 hrs	Every 3 Months or 25 hrs	Every 6 Months or 50 hrs	Every Year or 100 hrs	Every 2 Years or 200 hrs	
Engine Oil	CHECK	X						
	CHANGE		X					
Air Cleaner	CHECK	X						
	CHANGE			X (1)				
All Nuts and Bolts	Re-tighten If Necessary	X						
Cooling Fins	CHECK				X			
Fuel Tank	CLEAN					X		
Fuel Filter	CHECK					X		
Idle Speed	CHECK-ADJUST					X (2)		
Valve Clearance	CHECK-ADJUST						X (2)	
Fuel lines	CHECK		Every 2 years (replace if necessary) (2)					

1. Service more frequently when used in **DUSTY** areas.
2. These items should be serviced by your service dealer, unless you have the proper tools and are mechanically proficient. Refer to the **HATZ** Shop Manual for service procedures.
3. For commercial use, log hours of operation to determine proper maintenance intervals.



## MACHINE INSPECTION

Perform machine inspection as listed in Table 6.

Interval	Check	Solution
Daily Before Starting	Machine	Clean if necessary.
	Fuel Tank For Leaks	Repair fuel leaks.
	Fuel System for Leaks	Repair fuel leaks.
	Engine Oil	Add oil if necessary.
	Vibrator Oil	Add oil if necessary.
	Air Cleaner Element	Clean/Replace
	Guard Frame	Inspect/deformations
	Shock Absorber	Replace if damaged.
	Hydraulic pump	Check/Repair Leaks
	Hydraulic Pipe System	Check/Repair leaks, Inspect for wear
	Direction Control Lever	Check bolts/nuts, Inspect for wear
Every 20 Hours	Duct Hose	Check for crack/damage
Every 100 Hours	Engine Oil/Oil Filter	Replace only after first 20 hrs.
	Engine Oil	Change
	Engine Oil Filter	Wash
	Vibrator Oil	Check oil level. Check for leaks/dirt.
	Hydraulic Oil	Check oil level. Check for leaks.
Every 200 hours	Battery Terminal	Clean
	V-Belt	Inspect, replace if damaged or worn.
	Clutch	Inspect, replace if not working properly.
Every 300 hours	Engine Bolts	Replace bolts if deformed or elongated.
	Vibrator Oil	Change
	Fuel Filter	Change
	Hydraulic Oil	Change
Every 2 years	Engine Oil Filter	Change
Every 2 years	Fuel Lines	Replace

## TIGHTENING TORQUE

Reference Table 7 below (Tightening Torque ), for retightening of nuts and bolts.

Material	6mm	8mm	10mm	12mm	14mm	16mm	18mm	20mm
4T	70	150	300	500	750	1,100	1,400	2,000
6-8T	100	250	500	800	1,300	2,000	2,700	3,800
11T	150	400	800	1,200	2,000	2,900	4,200	5,600
*	100 (6mm) 300 ~ 350 (8mm) 650 ~ 700 (10mm)							
**	In case counter-part is of aluminum							
Bolt threads used with this machine are all right handed								
Material and quality of material is marked on each bolt, and screw.								

## ENGINE AIR CLEANER

**CAUTION**



Wear protective equipment such as approved safety glasses or face shields and dust masks or respirators when cleaning air filters with compressed air.

This engine is equipped with a replaceable, high-density paper air cleaner element. See (Figure 21) for air cleaner components.

1. Remove the air cleaner cover and foam filter element.
2. Tap the paper filter element several times on a hard surface to remove dirt, or blow compressed air not exceeding 30 psi (207 kPa, 2.1 kgf/cm<sup>2</sup>) through the filter element from the inside out. **NEVER** brush off dirt. Brushing will force dirt into the fibers. Replace the paper filter element if it is excessively dirty.

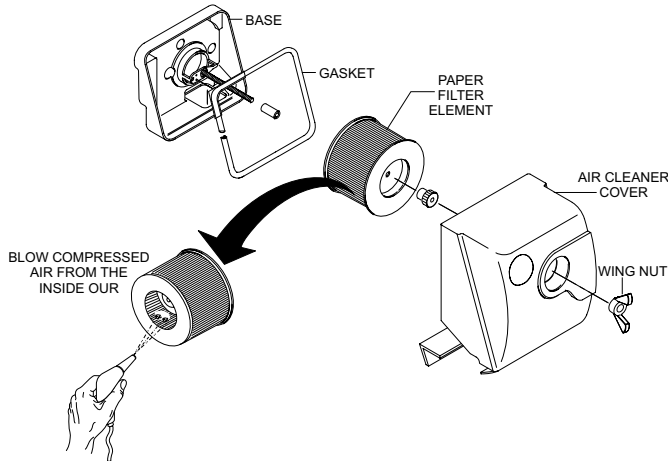

**Figure 21. Engine Air Cleaner**

### NOTICE

Operating the engine with loose or damaged air cleaner components could allow unfiltered air into the engine causing premature wear and failure.

### DUST POT

Always clean the dust pot. A clogged dust pot reduces cyclone effect with cleaner element wearing easily.

1. Release locking latches (Figure 22) on dust pot and remove dust pot from air cleaner body.

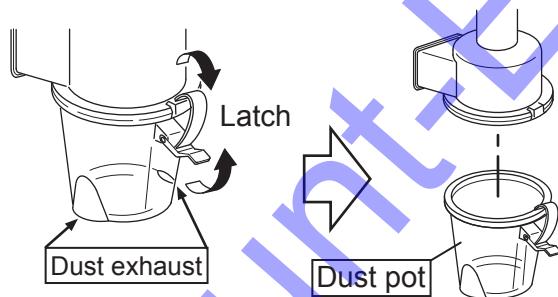

**Figure 22. Unlatching Dust Pot**

2. Clean dust pot with water and neutral detergent.
3. Reinstall dust pot onto air cleaner body and secure dust pot with locking latches (Figure 23).

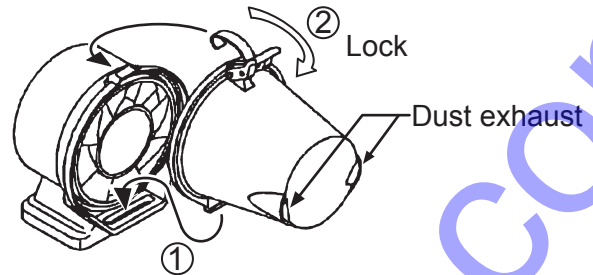

**Figure 23. Latching Dust Pot**

### ENGINE OIL

#### NOTICE

Drain the engine oil when the oil is warm.

1. Remove the oil drain bolt (Figure 24). and sealing washer and allow the oil to drain into a suitable container.
2. Replace engine oil with recommended type oil as listed in Table 4. For engine oil capacity, see Table 2 (Engine Specifications). **DO NOT** overfill.
3. Reinstall drain bolt with sealing washer and tighten securely.

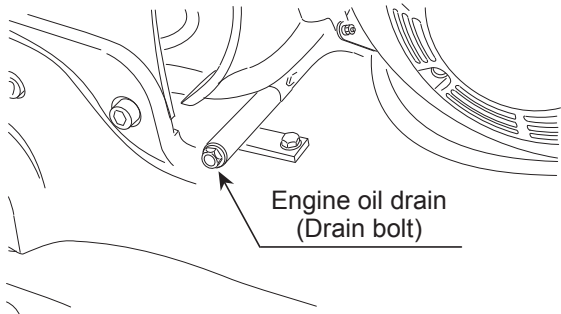

**Figure 24. Draining Engine Oil**

## HYDRAULIC OIL

1. With the handle in vertical position, remove the plug cap from the hydraulic pump (Figure 25).

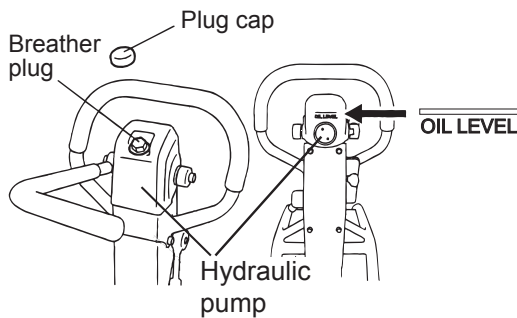

**Figure 25. Removing Plug/Breather Cap**

2. Remove the breather plug with a 24 mm wrench at the top of the hydraulic pump.
3. Remove the hydraulic hose connected to the cylinder on the vibrator side (Figure 26).

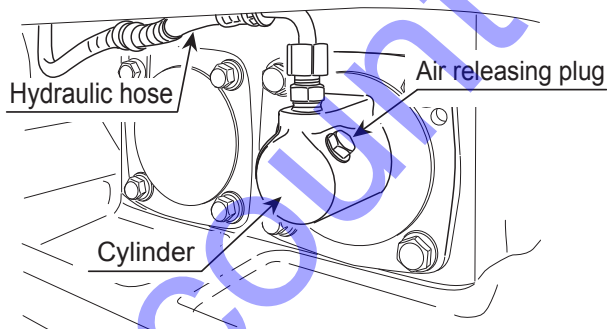

**Figure 26. Removing Hydraulic Hose**

4. Set the run lever to reverse.
5. Drain the hydraulic oil from the pump.
6. After the oil is drained, attach the hydraulic hose again to the cylinder on the vibrator side.

7. With the direction control lever at the forward-most position, secure the guard frame with a rope to immobilize (Figure 27).

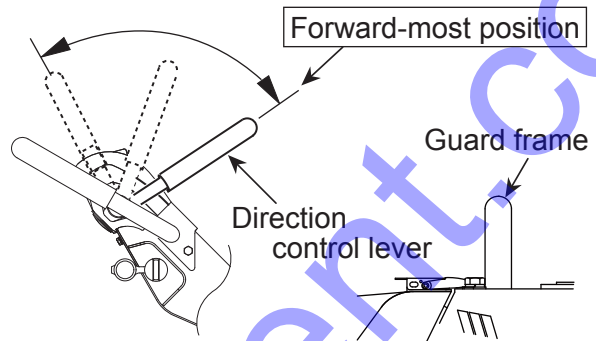

**Figure 27. Direction Control Lever (Forward Position)**

8. Pour hydraulic oil (550cc) to the hydraulic pump breather plug attachment hole (Figure 25).
9. Remove the air releasing plug of vibrator cylinder. Oil will then come out from the air releasing plug. After air bubbles stop coming out, reattach the plug. Tighten securely (Figure 26).
10. Release the direction control lever and move the lever forward and reverse several times (until no air bubbles are seen). Keep the lever at the forward position for 10 seconds every time. (Because the check valve is opened at the maximum forward position and air bubble will come out from the oil tank of the hydraulic pump).
11. In case the air bleeding is insufficient, repeat steps 9 and 10.
12. Attach the hydraulic pump breather plug and put on the plug cap. After making sure the hydraulic oil in the pump is at OIL LEVEL, attach the breather plug.

### **CAUTION**

Do not exceed OIL LEVEL of hydraulic oil. If the level is higher, oil will burst out from the breather plug.

## V-BELT

Visually examine the V-belt (Figure 28) and determine if it is full of tiny cracks, frayed, has pieces of rubber missing, is peeling or otherwise damaged.

Also, examine the belt and determine if it is **oil soaked** or "**glazed**" (hard shiny appearance on the sides of the belt). Either of these two conditions can cause the belt to run hot, which can weaken it and increase the danger of it breaking.

If the V-belt exhibits any of the above wear conditions replace the V-belt immediately.

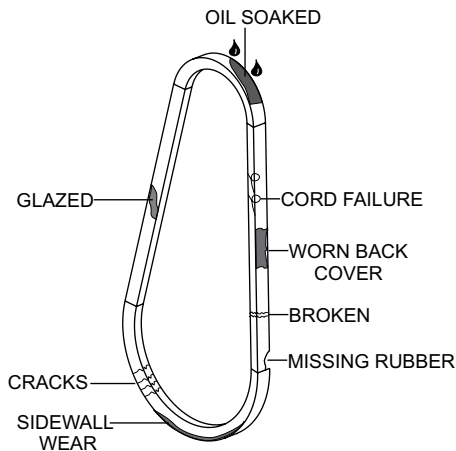

Figure 28. V-Belt Inspection

## BATTERY

The standard battery installed is a maintenance-free battery. It is not necessary to supply battery fluid. In case of a sudden voltage drop, the battery cannot be charged quickly, so it has to be replaced with a new one.

### Checking Battery Capacity

1. Check the battery checker on the hour tachometer (Figure 29).

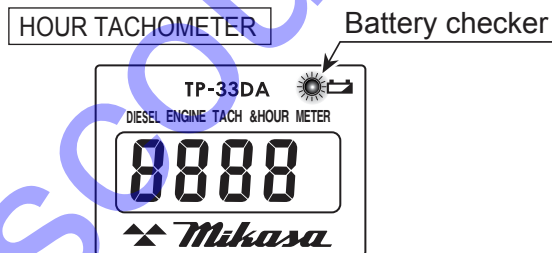

Figure 29. Battery Check

2. When the battery charge gets low, the battery checker lights red.

### NOTICE

If an old battery is used, even when the battery checker is not lighted (indicating low charge), the cell starter might not operate because of low charging level. If that happens, change the battery with the new one.

### Changing the Battery

1. Unlatch the two stoppers at the top portion of the rear cover to open the rear cover (Figure 30).

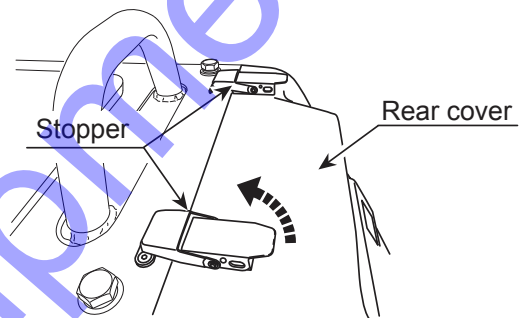

Figure 30. Opening Rear Cover

2. Loosen the two bolts on each side of the bar connecting the battery to the side rails (Figure 31)

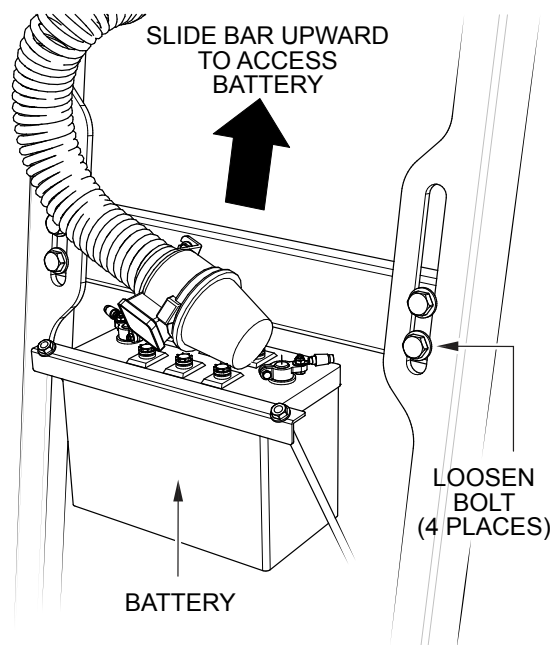
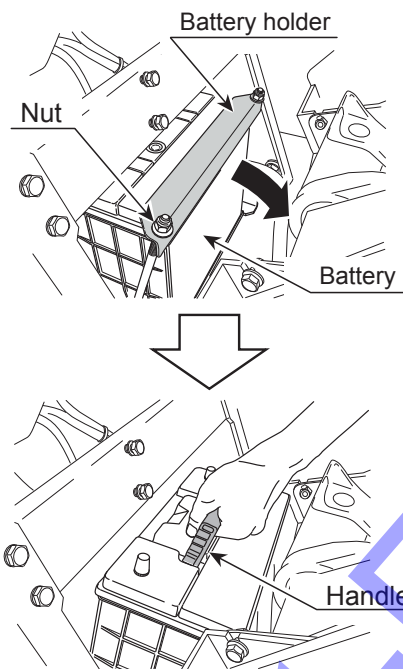

Figure 31. Raising The Battery

## MAINTENANCE

3. Slide the bar up the notches for easy access to the battery and tighten the bolts.
4. Take off the nuts and remove the battery holder (Figure 32).
5. After tilting the battery backward, disconnect the battery terminal. Always disconnect the black terminal on the negative side first.
6. Pull up the handle on the top of the battery to remove the battery from the machine.(Figure 32). Make sure that the battery terminals do not touch the frame.



**Figure 32. Removing Battery**

7. To install new battery, perform the procedure in reverse. Make sure that the red terminal (positive side) is connected first.
8. Loosen the two bolts on each side of the battery bracket and slide the bracket down to lower the battery to its original location.
9. Tighten the four bolts.

## STORAGE

1. Wash off dirt and soil from every part with water. While washing, be careful not to let the water splash on the electric components such as the battery and the engine muffler.
2. Cover the machine to prevent dust and dirt buildup.
3. Store the machine in a dry area away from direct sunlight.
4. Do not leave the machine outdoors. Keep it indoors.
5. When not used for a long period of time, drain the fuel from the fuel tank, and either disconnect the battery terminals or remove the battery itself.
6. When the machine is used after a long storage period, check the level of engine oil and battery capacity before using.

## TROUBLESHOOTING (COMPACTOR)

Troubleshooting (Compactor)		
Symptom	Possible Problem	Solution
Travel speed low and vibration weak.	Clutch slips?	Adjust or replace clutch.
	V-belt slips?	Adjust or replace V-belt.
	Excessive oil in vibrator?	Fill to correct level.
	Trouble in vibrator internals?	Check vibrator assembly for any worn or defective parts, replace any defective parts.
	Aeration in hydraulic oil for for travel reversing system?	Purge air in hydraulic oil. (Bleed plug)
	Engine speed incorrect?	Set engine speed to correct RPM.
Travels forward or backward but unable to switch direction.	Hydraulic pump problems?	Check hydraulic pump.
	Direction Control Lever installation wrong?	Correct installation of IDirection Control Lever.
	Broken or defective oil hose?	Replace oil hose.
	Aeration in hydraulic oil?	Purge air in hydraulic oil. (Bleed plug)
	Excessive oil in reversing system?	Fill to correct level.
	Hydraulic pump clogged with trash?	Clean valve inside hydraulic pump.
	Cylinder piston bearing failure?	Check piston bearing in cylinder for leakage.
Does not travel in forward or reverse	V-belt disengaged or slips?	Engage V-belt, adjust or replace.
	Clutch slips?	Adjust clutch, replace if necessary.
	Vibrator locks?	Check vibrator and correct problem.
	Cylinder piston bearing failure?	Check piston bearing in cylinder for leakage at USH packing.
Direction Control Lever operating resistance for reverse is high.	Piston inside hydraulic pump not moving smoothly?	Adjust or replace.
	Vibrator cylinder piston does not move smoothly	Adjust or replace.

## TROUBLESHOOTING (ENGINE)

Troubleshooting (Engine)		
Symptom	Possible Problem	Solution
Engine will not start or start is delayed, although engine can be turned over.	No Fuel reaching injection pump?	Add fuel. Check entire fuel system.
	Defective fuel pump?	Replace fuel pump.
	Fuel filter clogged?	Replace fuel filter and clean tank.
	Faulty fuel supply line?	Replace or repair fuel line.
	Compression too low?	Check piston, cylinder and valves. Adjust or repair per engine repair manual.
	Fuel pump not working correctly?	Repair or replace fuel pump.
	Oil pressure too low?	Check engine oil pressure.
	Low starting temperature limit exceeded?	Comply with cold starting instructions and proper oil viscosity.
	Defective battery?	Charge or replace battery.
	Air or water mixed in fuel system?	Check carefully for loosened fuel line coupling, loose cap nut, etc.
At low temperatures engine will not start.	Engine oil too thick?	Refill engine crankcase with correct type of oil for winter environment.
	Defective battery?	Replace battery.
Engine fires but stops soon as starter is switched off.	Fuel filter blocked?	Replace fuel filter.
	Fuel supply blocked?	Check the entire fuel system.
	Defective fuel pump?	Replace fuel pump.
Engine stops by itself during normal operation.	Fuel tank empty?	Add fuel.
	Fuel filter blocked?	Replace fuel filter.
	Defective fuel pump?	Replace fuel pump.
	Mechanical oil pressure shutdown sensor stops the engine due to low oil?	Add oil. Replace low oil shutdown sensor if necessary.
Low engine power, output and speed.	Fuel tank empty?	Replace fuel filter.
	Fuel filter clogged?	Replace fuel filter.
	Fuel tank venting is inadequate?	Ensure that tank is adequately vented.
	Leaks at pipe unions?	Check threaded pipe unions tape and tighten unions as required.
	Speed control lever does not remain in selected position?	See engine manual for corrective action.
	Engine oil level too full?	Correct engine oil level.
	Injection pump wear?	Use No. 2-D diesel fuel only. Check the fuel injection pump element and delivery valve assembly and replace as necessary.

## TROUBLESHOOTING (ENGINE)

Troubleshooting (Engine) - continued		
Symptom	Possible Problem	Solution
Low engine power output and low speed, black exhaust smoke.	Air filter blocked?	Clean or replace air filter.
	Incorrect valve clearances?	Adjust valves per engine specification.
	Malfunction at injector?	See engine manual.
Engine overheats.	Too much oil in engine crankcase?	Drain off engine oil down to uppermark on dipstick.
	Entire cooling air system contaminated/ blocked?	Clean cooling air system and cooling fin areas.
	Fan belt broken or elongated?	Change belt or adjust belt tension.
	Coolant insufficient?	Replenish coolant.
	Radiator net or radiator fin clogged with dust?	Clean net or fin carefully.
	Fan, radiator, or radiator cap defective?	Replace defective part.
	Thermostat defective?	Check thermostat and replace if necessary.
Head gasket defective or water leakage?	Replace parts.	



# EXPLANATION OF CODE IN REMARKS COLUMN

The following section explains the different symbols and remarks used in the Parts section of this manual. Use the help numbers found on the back page of the manual if there are any questions.

## NOTICE

The contents and part numbers listed in the parts section are subject to change **without notice**. Multiquip does not guarantee the availability of the parts listed.

## SAMPLE PARTS LIST

NO.	PART NO.	PART NAME	QTY.	REMARKS
1	12345	BOLT .....	1	INCLUDES ITEMS W/%
2%		WASHER, 1/4 IN. ....		NOT SOLD SEPARATELY
2%	12347	WASHER, 3/8 IN. ...	1	MQ-45T ONLY
3	12348	HOSE .....	A/R	MAKE LOCALLY
4	12349	BEARING .....	1	S/N 2345B AND ABOVE

## NO. Column

**Unique Symbols** — All items with same unique symbol (@, #, +, %, or >) in the number column belong to the same assembly or kit, which is indicated by a note in the “Remarks” column.

**Duplicate Item Numbers** — Duplicate numbers indicate multiple part numbers, which are in effect for the same general item, such as different size saw blade guards in use or a part that has been updated on newer versions of the same machine.

## NOTICE

When ordering a part that has more than one item number listed, check the remarks column for help in determining the proper part to order.

## PART NO. Column

**Numbers Used** — Part numbers can be indicated by a number, a blank entry, or TBD.

TBD (To Be Determined) is generally used to show a part that has not been assigned a formal part number at the time of publication.

A blank entry generally indicates that the item is not sold separately or is not sold by Multiquip. Other entries will be clarified in the “Remarks” Column.

## QTY. Column

**Numbers Used** — Item quantity can be indicated by a number, a blank entry, or A/R.

A/R (As Required) is generally used for hoses or other parts that are sold in bulk and cut to length.

A blank entry generally indicates that the item is not sold separately. Other entries will be clarified in the “Remarks” Column.

## REMARKS Column

Some of the most common notes found in the “Remarks” Column are listed below. Other additional notes needed to describe the item can also be shown.

**Assembly/Kit** — All items on the parts list with the same unique symbol will be included when this item is purchased.

Indicated by:

“INCLUDES ITEMS W/(unique symbol)”

**Serial Number Break** — Used to list an effective serial number range where a particular part is used.

Indicated by:

“S/N XXXXX AND BELOW”

“S/N XXXX AND ABOVE”

“S/N XXXX TO S/N XXX”

**Specific Model Number Use** — Indicates that the part is used only with the specific model number or model number variant listed. It can also be used to show a part is NOT used on a specific model or model number variant.

Indicated by:

“XXXXX ONLY”

“NOT USED ON XXXX”

**“Make/Obtain Locally”** — Indicates that the part can be purchased at any hardware shop or made out of available items. Examples include battery cables, shims, and certain washers and nuts.

**“Not Sold Separately”** — Indicates that an item cannot be purchased as a separate item and is either part of an assembly/kit that can be purchased, or is not available for sale through Multiquip.

## SUGGESTED SPARE PARTS

### MVH408DZ PLATE COMPACTOR WITH 1B50 DIESEL ENGINE

#### 1 to 3 units

Qty.	P/N	Description
4	939010260	SHOCK ABSORBER
4	939010010	SHOCK ABSORBER
2	070200463	V-BELT HDPF-5460
1	50384401	IGNITION SWITCH W/ KEYS
3	50404900	KEY, IGNITION SWITCH
3	01542703	OIL SUCTION FILTER ASSY.
3	01635210	FUEL FILTER
1	01919702	FUEL FILTER
3	50484100	ELEMENT, AIR FILTER
1	01535302	CAP, FUEL TANK

#### NOTICE

Part numbers on this Suggested Spare Parts list may supersede/replace the part numbers shown in the following parts lists.

# VIBRATING PLATE ASSY.

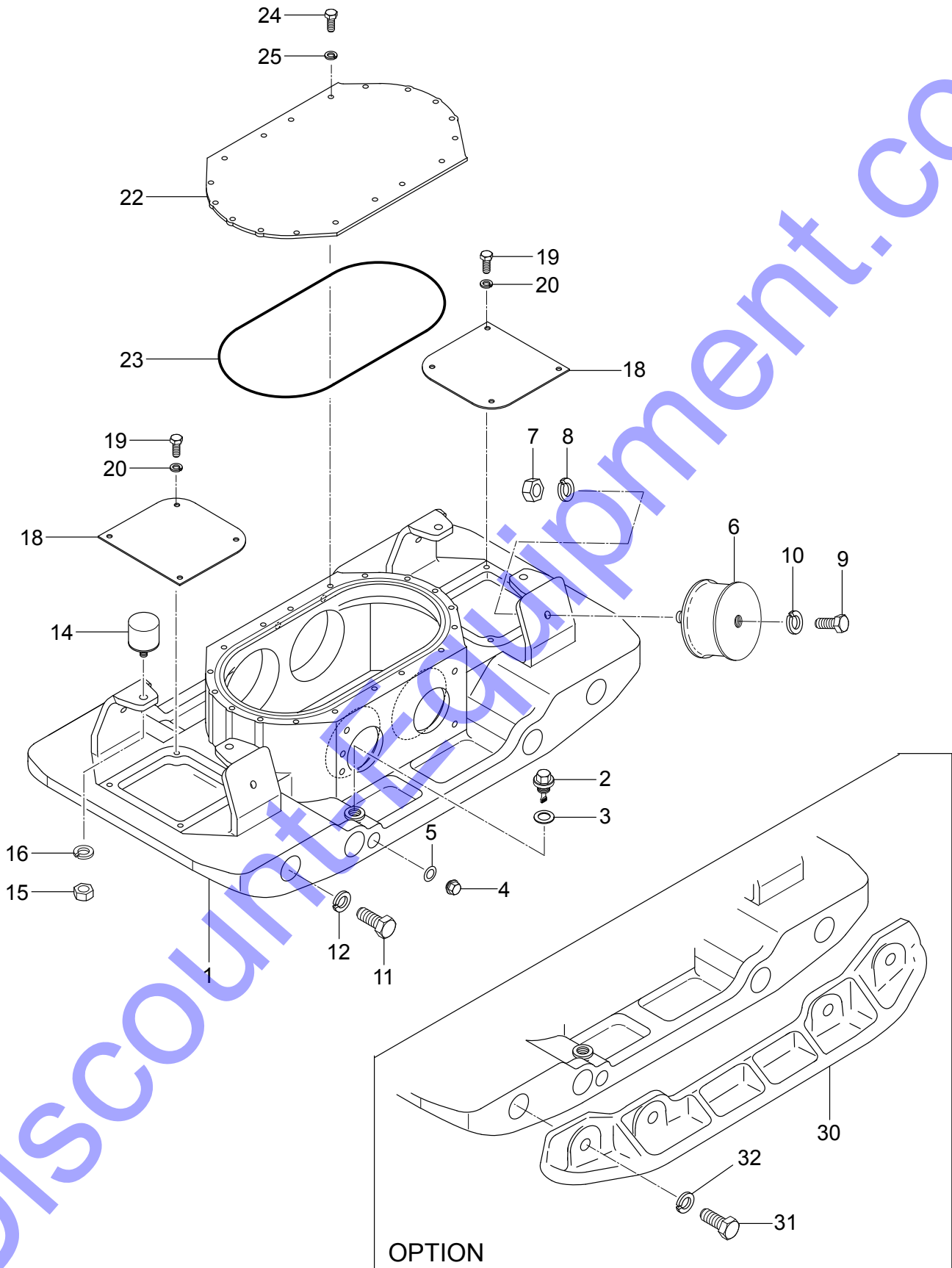

## VIBRATING PLATE ASSY.

<u>NO.</u>	<u>PART NO.</u>	<u>PART NAME</u>	<u>QTY.</u>	<u>REMARKS</u>
1	468121200	VIBRATING PLATE	1	
2	465460670	OIL GAUGE	1	
3	953402930	COPPER PACKING	1	
4	953400270	PLUG	1	
5	953405260	PACKING	1	
6	939010260	SHOCK ABSORBER	4	
7	020316130	NUT M16	4	
8	030216400	WASHER, LOCK M16	4	
9	001221635	BOLT 16X35	4	
10	030216400	WASHER, LOCK M16	4	
11	001221830	BOLT 18X30	8	
12	58407	WASHER, LOCK M18 .....	8.....	REPLACES P/N 030218460
14	939010010	SHOCK ABSORBER	4	
15	020310080	NUT M10	4	
16	030210250	WASHER, LOCK M10	4	
18	468352110	COVER, VIBRATING PLATE	2	
19	014208020	BOLT 8X20.....	8.....	REPLACES P/N 001220820
20	030208200	WASHER, LOCK M8	8	
22	467351790	COVER, VIBRATOR	1	
23	050103250	O-RING	1	
24	014208020	BOLT 8X20.....	18.....	REPLACES P/N 001220820
25	030208200	WASHER, LOCK M8	18	
30	467219050	EXTENSION PLATE	2	
31	012218050	BOLT 18X50.....	8.....	REPLACES P/N 001221850
32	58407	WASHER, LOCK M18 .....	8.....	REPLACES P/N 030218460

# VIBRATOR ASSY.

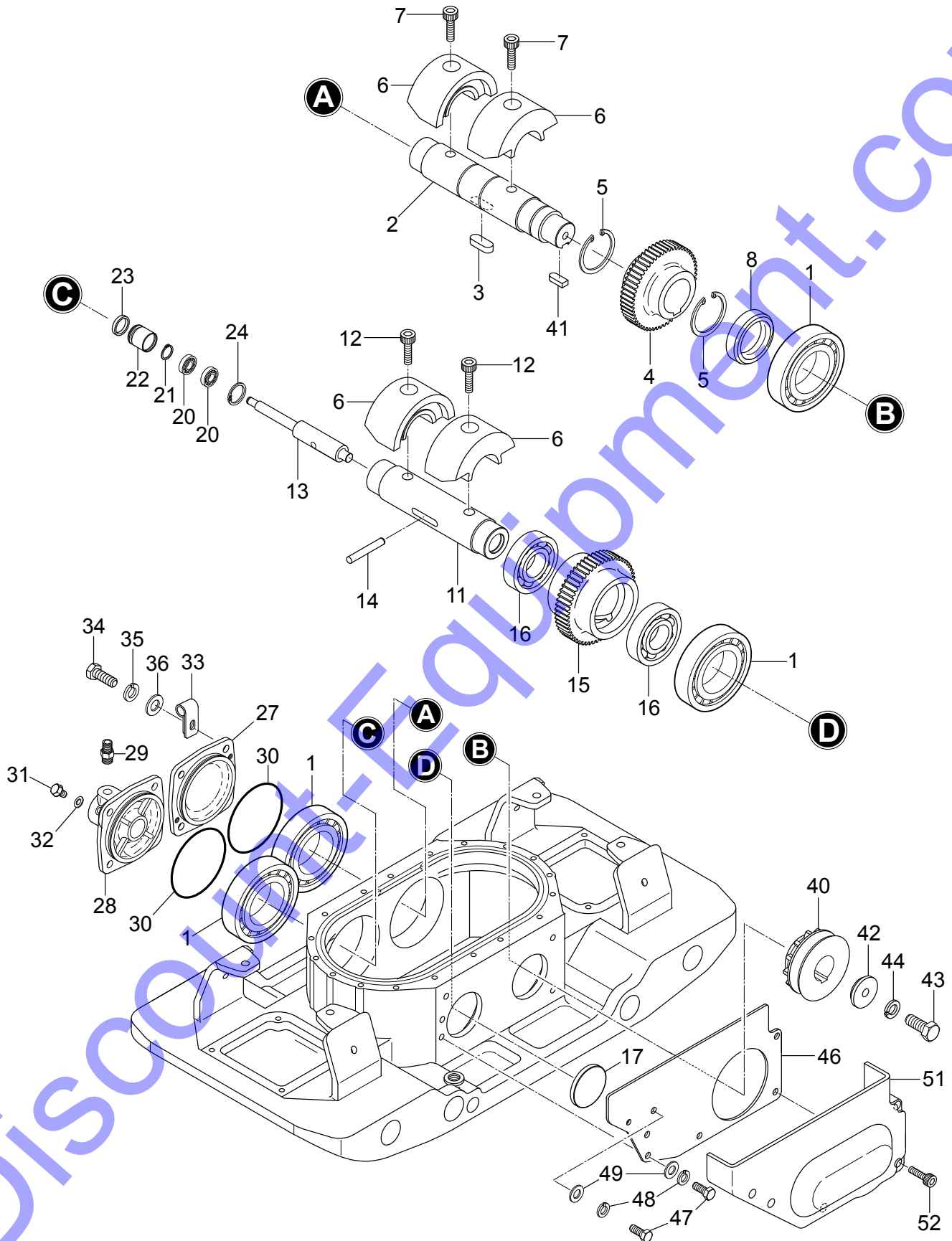

# VIBRATOR ASSY.

<u>NO.</u>	<u>PART NO.</u>	<u>PART NAME</u>	<u>QTY.</u>	<u>REMARKS</u>
1	047920120	ROLLER BEARING	4	
2	457212410	ROTARY SHAFT,DRIVE	1	
3	951405370	KEY 15X10X39	1	
4	456327150	GEAR, DRIVE	1	
5	080200550	STOP RING	2	
6	468352210	ECCENTRIC ROTATOR	4	
7	009120301	SOCKET HEAD BOLT 16X40	2	
8	060105030	OIL SEAL	1	
11	456337670	ROTARY SHAFT, DRIVEN	1	
12	009120302	SOCKET HEAD BOLT 16X30	2	
13	456337380	PISTON ROD	1	
14	456010010	KNOCK PIN 10X70	1	
15	467351910	GEAR (DRIVEN)	1	
16	040006911	BEARING	2	
17	953010030	SEAL CAP	1	
20	042506000	BEARING 6000ZZSG	2	
21	0080000010	STOP RING .....	1	REPLACES P/N 080200100
22	455435051	PISTON	1	
23	455010070	PACKING	1	
24	080100260	STOP RING	1	
27	467352540	BEARING COVER	1	
28	467219070	CYLINDER (R)	1	
29	954010020	CONNECTOR PT, PF1/4	1	
30	050101050	O-RING	2	
31	001720812	FLANGE BOLT 8X12	1	
32	953404600	COPPER PACKING	1	
33	959408880	CLIP 15 (M10)	1	
34	0105091025	BOLT 10X25.....	8	REPLACES P/N 001221025
35	030210250	WASHER, LOCK M10	8	
36	031110160	WASHER, FLAT M10	8	
40	465345090	PULLEY	1	
41	951404970	KEY 12X8X30	1	
42	456437920	WASHER, PULLEY	1	
43	012212035	BOLT 12X35.....	1	REPLACES P/N 001221235
44	030212300	WASHER, LOCK M12	1	
46	467351920	GUIDE, BELT COVER	1	
47	014208020	BOLT 8X20.....	2	REPLACES P/N 001220820
48	030208200	WASHER, LOCK M8	2	
49	401450080	WASHER, FLAT M8 .....	2	REPLACES P/N 031108160
51	468218960	BELT COVER, LOWER	1	
52	001520856	SOCKET HEAD BOLT 8X80	5	

# BASE AND ENGINE ASSY.

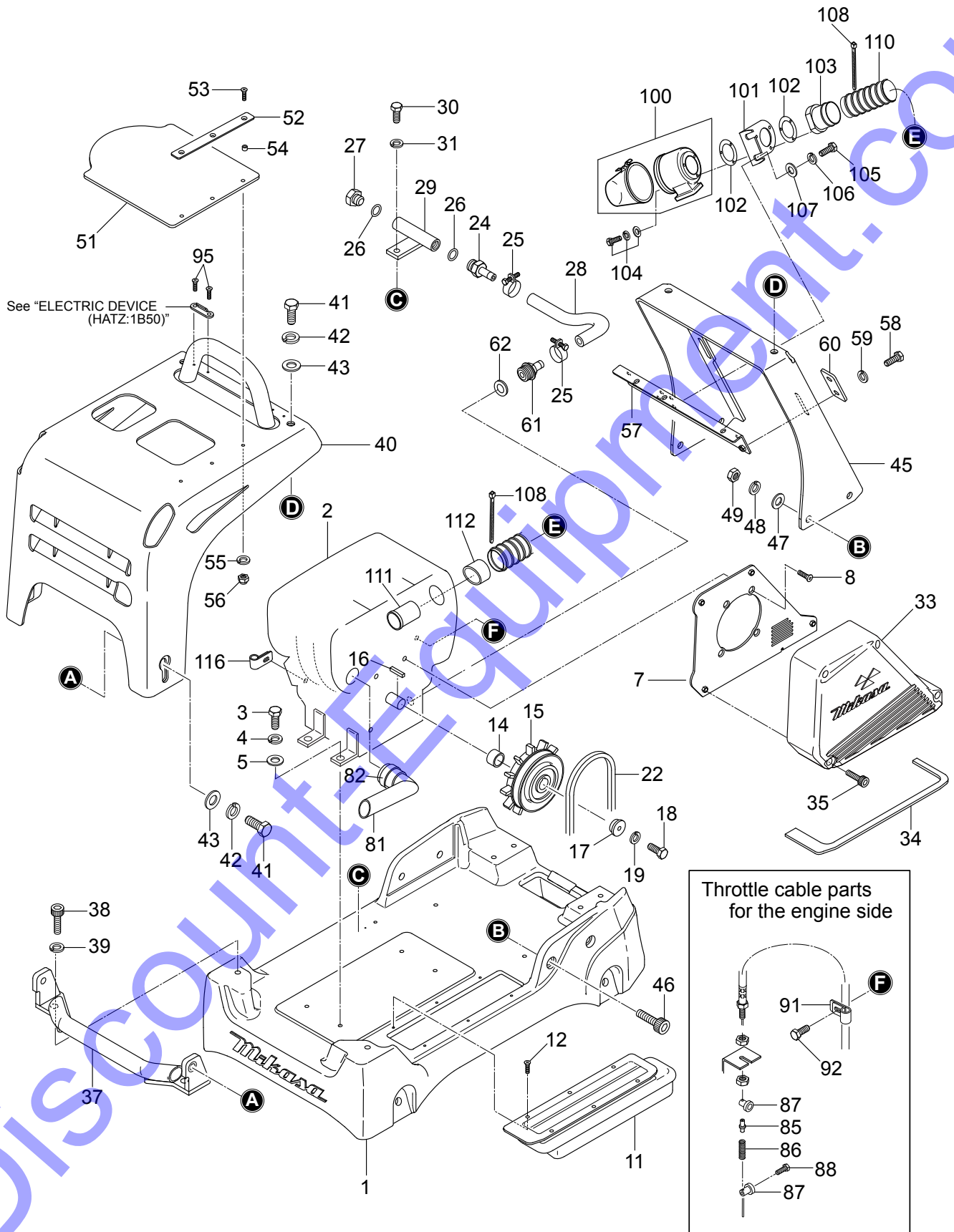

## BASE AND ENGINE ASSY.

<u>NO.</u>	<u>PART NO.</u>	<u>PART NAME</u>	<u>QTY.</u>	<u>REMARKS</u>
1	468121250	BASE	1	
2	918401100	ENGINE ASSY. 1B50T-9-166 HATZ	1	
3	012010030	BOLT 10X30 .....	4	REPLACES P/N 001221030
4	030210250	WASHER, LOCK M10	4	
5	031110160	WASHER, FLAT M10	4	
7	468352230	BELT COVER, IN	1	
8	009120416	SUNK HEAD BOLT 10X25	4	
11	468352120	DUST COVER	1	
12	092006010	FLAT HEAD SCREW 6X10	6	
14	952408830	SPACER 25X31.8X18	1	
15	468352380	CLUTCH ASSY.	1	
16	951400110	KEY 7X7X35	1	
17	952408840	SPECIAL WASHER	1	
18	012010030	BOLT 10X30.....	1	REPLACES P/N 001221030
19	030210250	WASHER, LOCK M10	1	
22	070200463	V-BELT HDPF-5460	1	
24	954407310	UNION, DRAIN	1	
25	0091720000	HOSE CLAMP	2	
26	0211140020	GASKET	2	
27	0401140030	PLUG	1	
28	465459390	DRAIN HOSE	1	
29	464457380	DRAIN JOINT	1	
30	014208020	BOLT 8X20 .....	1	REPLACES P/N 001220820
31	030208200	WASHER, LOCK M8	1	
33	468218930	BELT COVER (OUT)	1	
34	468352130	DUST SPONGE (OUT)	1	
35	001521056	SOCKET HEAD BOLT 10X80	4	
37	468352140	FRONT BUMPER	1	
38	001521435	SOCKET HEAD BOLT 14X35	2	
39	030214350	WASHER, LOCK M14	2	
40	468121210	FRONT COVER	1	
41	001221445	BOLT 14X45	4	
42	030214350	WASHER, LOCK M14	4	
43	031114260	WASHER, FLAT M14	4	
45	468218941	CENTER COVER	1	
46	001521435	SOCKET HEAD BOLT 14X35	4	
47	031114260	WASHER, FLAT M14	4	
48	030214350	WASHER, LOCK M14	4	
49	020314110	NUT M14	4	
51	468466890	RUBBER COVER UPPER	1	
52	467466760	STOPPER, COVER	1	
53	009120424	SOCKET HEAD BOLT 6X25	3	
54	617465130	COLLAR 6.2X7.8X4.5	3	
55	030206150	WASHER, LOCK M6	3	



# BASE AND ENGINE ASSY. (CONTINUED)

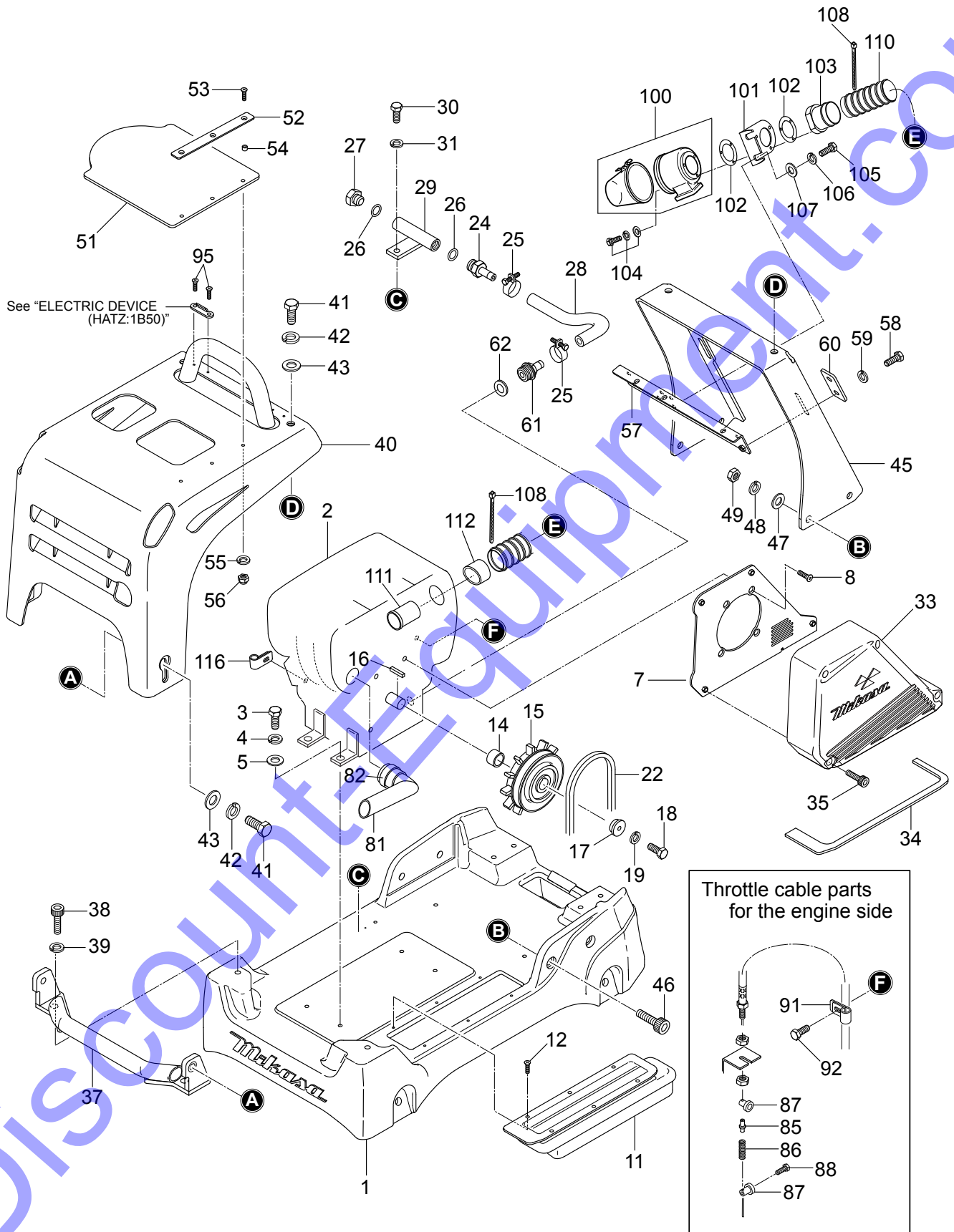

## BASE AND ENGINE ASSY. (CONTINUED)

<u>NO.</u>	<u>PART NO.</u>	<u>PART NAME</u>	<u>QTY.</u>	<u>REMARKS</u>
56	022710607	NYLON NUT M6	3	
57	467352720	CLEANER STAY	1	
58	011208025	BOLT 8X25.....	4	REPLACES P/N 001220825
59	030208200	WASHER, LOCK M8	4	
60	467467580	PLATE, CLEANER STAY	2	
61	465459670	OIL DRAIN	1	
62	DH50001600	JOINT A22X27	1	
81	468352160	EXHAUST PIPE	1	
82	DH03740900	PIPE CLIP	1	
85	DH05165000	GUIDE BUSH	1	
86	DH50484600	PRESSURE SPRING	1	
87	DH50483100	CABLE CLAMP	2	
88	DH50025000	HEX SCREW M 4X10/1B40	1	
91	2067550101	CLAMP COMPLETE	1	
92	011006010	BOLT 6X10 .....	1	REPLACES P/N 001220610
95	009120420	SOCKET HEAD BOLT 5X10	4	
100	466218080	CLEANER, CYCLONE	1	
101	468352180	CYCLONE STAY	1	
102	466462850	GASKET, AIR INTAKE	2	
103	467466840	JOINT, CLEANER	1	
104	009110057	SOCKET HEAD BOLT, 5X18	3	
105	014208020	BOLT 8X20.....	2	REPLACES P/N 001220820
106	030208200	WASHER, LOCK M8	2	
107	0401450080	WASHER, FLAT M8 .....	2	REPLACES P/N 031108160
108	506010060	CLAMP	2	
110	467351900	DUCT HOSE 50X390	1	
111	467466850	INTAKE PIPE	1	
112	467466860	GROMMET, CLEANER	1	
116	2267510103	CLAMP	2	

# ELECTRIC DEVICE ASSY.

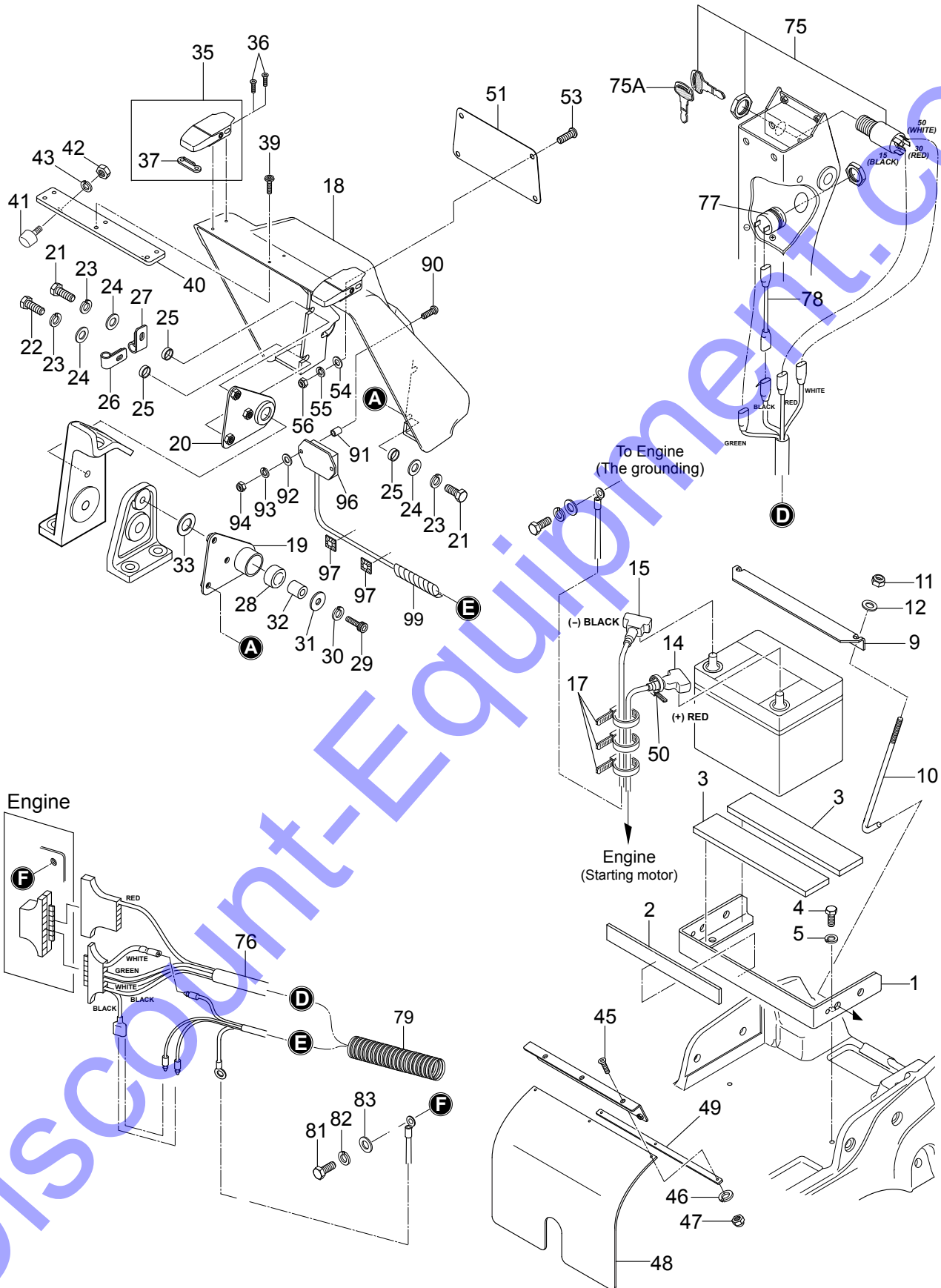

## ELECTRIC DEVICE ASSY.

<u>NO.</u>	<u>PART NO.</u>	<u>PART NAME</u>	<u>QTY.</u>	<u>REMARKS</u>
1	467218920	BATTERY HOLDER	1	
2	456447590	RUBBER PLATE	1	
3	456447600	RUBBER PLATE	2	
4	012210020	BOLT 10X20.....	2	REPLACES P/N 001221020
5	030210250	WASHER, LOCK M10	2	
9	464343740	HOLDER, BATTERY	1	
10	469467170	BOLT, BATTERY	2	
11	022710809	NYLON NUT M8	2	
12	0401450080	WASHER, FLAT M8 .....	2	REPLACES P/N 031108160
14	955301030	BATTERY CABLE (+)	1	
15	955301040	BATTERY CABLE (-)	1	
17	506010070	CLAMP	5	
18	468121270	REAR COVER	1	
19	467352020	BRACKET, REAR COVER (L)	1	
20	467352030	BRACKET REAR COVER (R)	1	
21	014208020	BOLT 8X20.....	5	REPLACES P/N 001220820
22	011208025	BOLT 8X25.....	1	REPLACES P/N 001220825
23	030208200	WASHER, LOCK M8	6	
24	0401450080	WASHER, FLAT M8 .....	6	REPLACES P/N 031108160
25	952408780	COLLAR	6	
26	959408920	CLIP 8 (M8)	1	
27	959408920	CLIP 8 (M8)	1	
28	416459340	RUBBER, VAS HANDLE	2	
29	014210040	SOCKET HEAD BOLT 10X40.....	2	REPLACES P/N 001521040
30	030210250	WASHER, LOCK M10	2	
31	952408740	WASHER	2	
32	952408790	COLLAR	2	
33	467467250	RUBBER WASHER	2	
35	467467090	CATCH CLIP .....	2	INCLUDES ITEM W/@
36	009120421	SOCKET HEAD BOLT 5X15	4	
37@	467467080	HOLDER, CATCH CLIP	2	
39	009110073	SOCKET HEAD SCREW 5X15	2	
40	468352220	BRACKET, STOPPER	1	
41	939010360	STOPPER RUBBER	2	
42	020108060	NUT M8 .....	2	REPLACES P/N 020308060
43	030208200	WASHER, LOCK M8	2	
45	009120422	SOCKET HEAD BOLT 5X20	3	
46	030205130	WASHER, LOCK M5	3	
47	022710506	NYLON NUT M5	3	
48	467466930	RUBBER PLATE, BATTERY	1	
49	468467110	STOPPER, RUBBER PLATE	1	
50	454010020	CLAMP	9	

# ELECTRIC DEVICE ASSY. (CONTINUED)

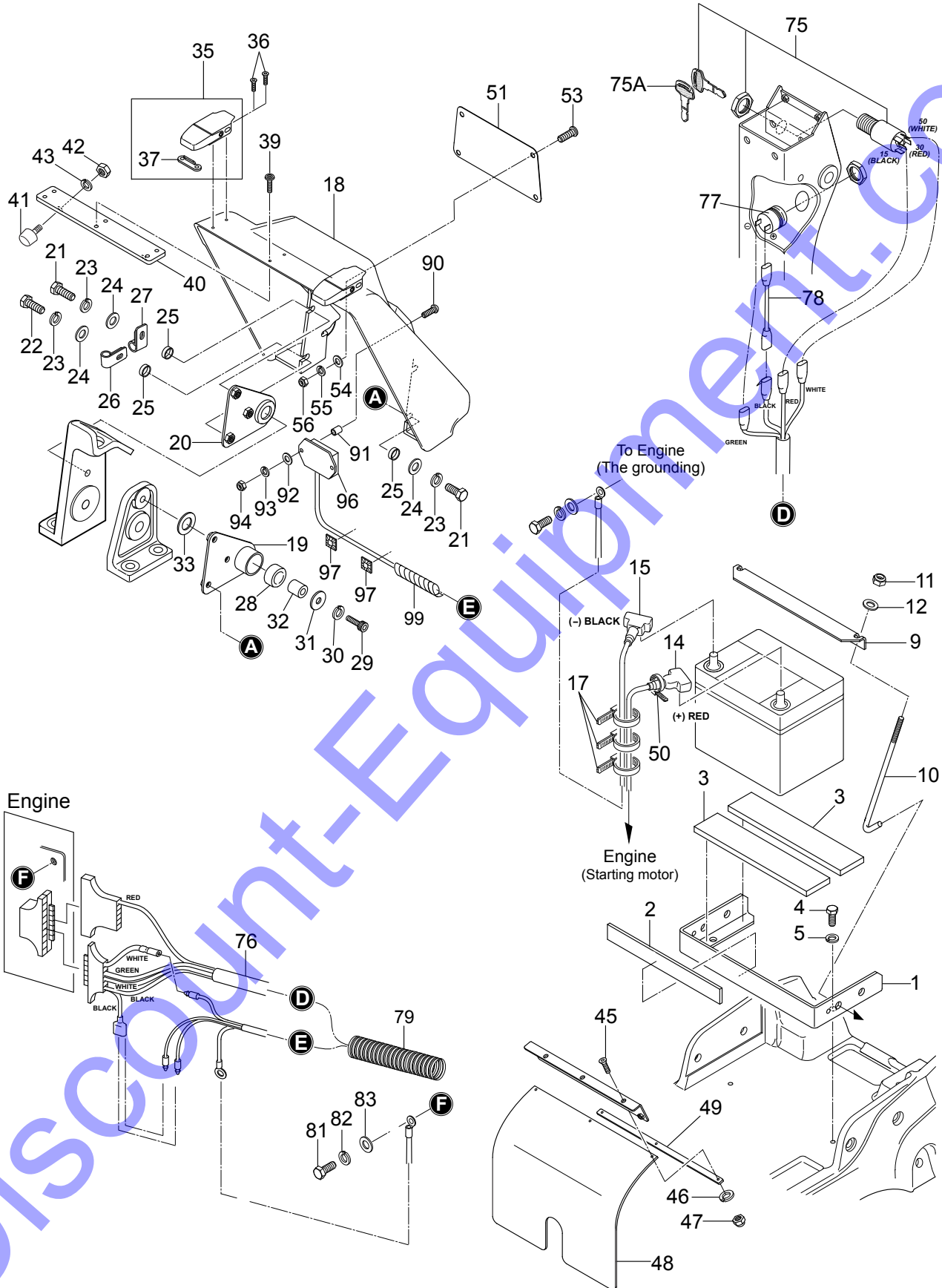

## ELECTRIC DEVICE ASSY. (CONTINUED)

<u>NO.</u>	<u>PART NO.</u>	<u>PART NAME</u>	<u>QTY.</u>	<u>REMARKS</u>
51	467352050	PANEL, REAR COVER	1	
53	009110062	SOCKET HEAD SCREW 6X20	4	
54	952404470	WASHER, LOCK M6 .....	4	REPLACES P/N 031106100
55	030206150	WASHER, FLAT M6	4	
56	022710607	NYLON NUT M6	4	
75	50384401	IGNITION SWITCH W/ KEYS .....	1	INCLUDES ITEM W/\$
75A\$	50404900	KEY, IGNITION SWITCH	1	
76	467352070	WIRE HARNESS	1	
77	50465100	BUZZER	1	
78	465459680	RELAY CABLE/BUZZER	1	
79	959026022	CORRUGATE TUBE	1	
81	001220612	BOLT 6X12	1	
82	030206150	WASHER, LOCK M6	1	
83	952404470	WASHER, FLAT M6 .....	1	REPLACES P/N 031106100
90	009110072	PAN HEAD SCREW 5X35	2	
91	952407930	COLLAR	2	
92	58151	WASHER, FLAT M5 .....	2	REPLACES P/N 031105080
93	030205130	WASHER, LOCK M5	2	
94	022710506	NYLON NUT M5	2	
96	955301020	TACH. AND HOUR METER	1	
97	955407970	WIRING FIXED BASE	2	
99	959021813	SPIRAL TUBE	1	

# CONTROL ASSY.

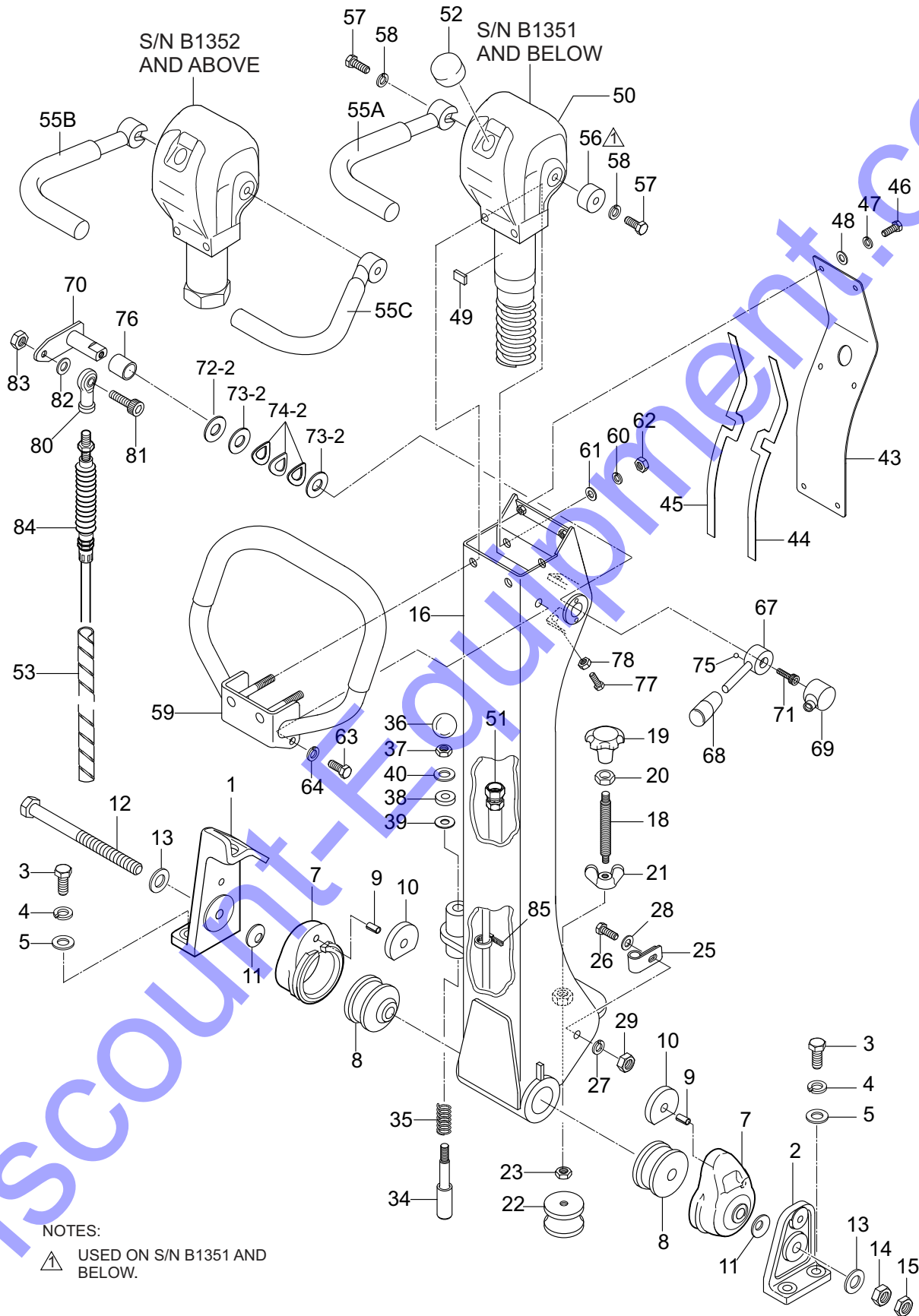

NOTES:  
 ▲ USED ON S/N B1351 AND BELOW.

**CONTROL ASSY.**

<b>NO.</b>	<b>PART NO.</b>	<b>PART NAME</b>	<b>QTY.</b>	<b>REMARKS</b>
1	467351950	HANDLE BRACKET (R)	1	
2	467351960	HANDLE BRACKET (L)	1	
3	012212035	BOLT 12X35.....	4	REPLACES P/N 001221235
4	030212300	WASHER, LOCK M12	4	
5	031112230	WASHER, FLAT M12	4	
7	456336400	RUBBER COUPLING	2	
8	456449940	SHOCK ABSORBER	2	
9	025306016	SPRING PIN 6X16 .....	2	REPLACES P/N 025406016
10	456449930	RUBBER PLATE	2	
11	032124400	CONICAL SPRING WASHER M24	2	
12	001221681	BOLT 16X250	1	
13	0401450160	WASHER, FLAT M16 .....	2	REPLACES P/N 031116260
14	020316130	NUT M16	1	
15	020416100	NUT M16	1	
16	467121170	COLUMN, HANDLE BAR	1	
18	455434950	SPINDLE	1	
19	455010030	KNOB	1	
20	020412070	NUT M12	1	
21	022411635	WING NUT M16	1	
22	939010060	SHOCK ABSORBER	1	
23	020310080	NUT M10.....	1	REPLACES P/N 020410060
25	959408930	CLIP 15	1	
26	011206020	BOLT 6X20.....	1	REPLACES P/N 001220620
27	030206150	WASHER, LOCK M6	1	
28	952404470	WASHER, FLAT M6 .....	1	REPLACES P/N 031106100
29	020106050	NUT M6 .....	1	REPLACES P/N 020306050
34	501402870	HANDLE STOPPER	1	
35	501402880	SPRING/HANDLE	1	
36	959403460	BALL GRIP	1	
37	020310080	NUT M10 .....	1	REPLACES P/N 020410060
38	456449980	RUBBER PACKING	1	
39	953405260	PACKING 1/4	1	
40	031110160	WASHER, FLAT M10	1	
43	467351970	HANDLE COVER	1	
44	467467340	PACKING (L), HANDLE	1	
45	467467350	PACKING (R), HANDLE	1	
46	0105050616	BOLT 6X15.....	6	REPLACES P/N 001220615
47	030206150	WASHER, LOCK M6	6	
48	952404470	WASHER, FLAT M6 .....	6	REPLACES P/N 031106100
49	464457930	RUBBER PIECE	1	
50	468219160	HYDRAULIC PUMP	1	



# CONTROL ASSY. (CONTINUED)

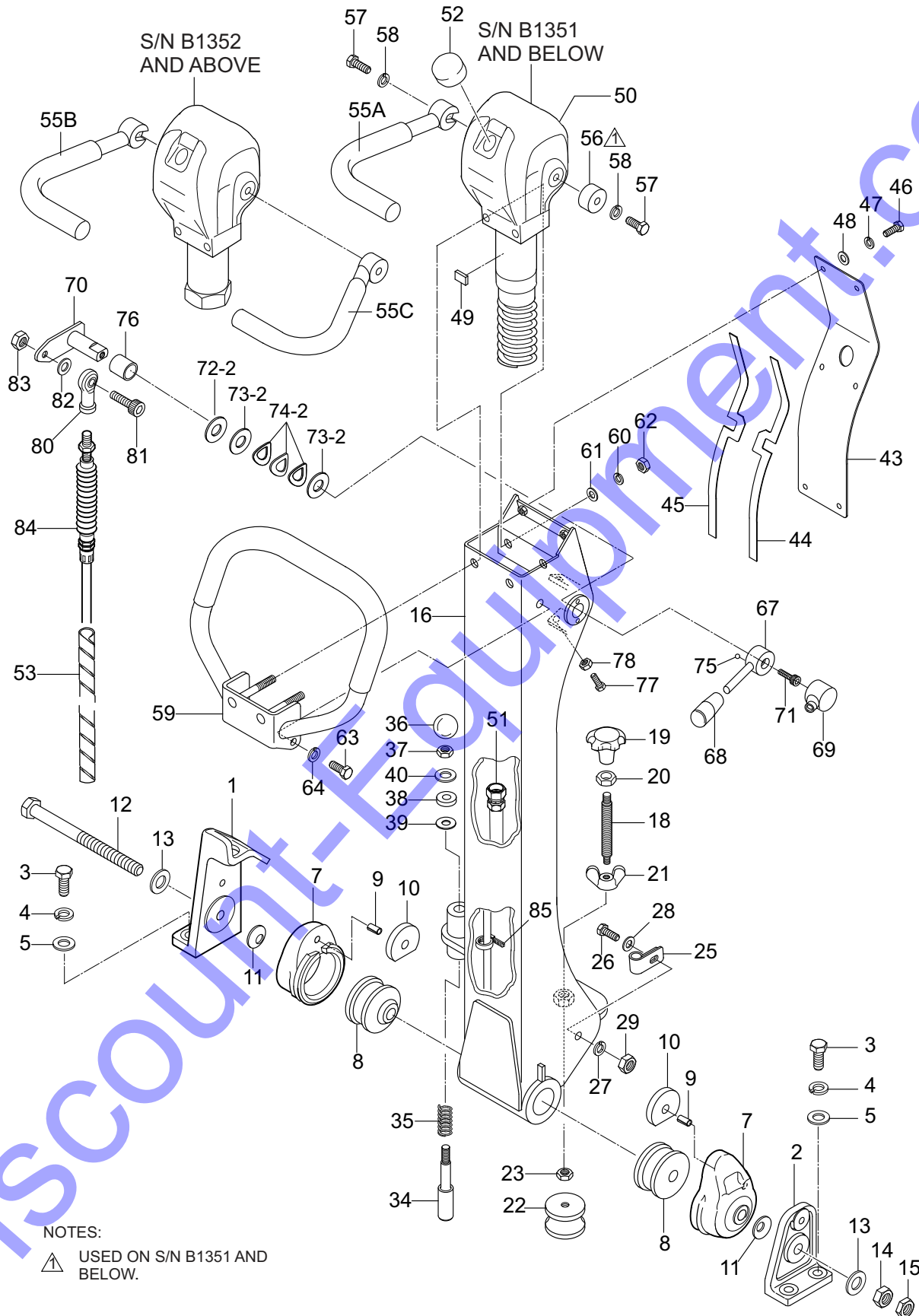

**NOTES:**

▲ USED ON S/N B1351 AND BELOW.

## CONTROL ASSY. (CONTINUED)

<u>NO.</u>	<u>PART NO.</u>	<u>PART NAME</u>	<u>QTY.</u>	<u>REMARKS</u>
51	954003110	OIL HOSE	1	
52	458451630	BREATHER CAP	1	
53	959021813	SPIRAL TUBE	1	
55A	464216630	TRAVEL LEVER, RIGHT .....	1	S/N 1351 AND BELOW
55B	464216820	TRAVEL LEVER, RIGHT .....	1	S/N 1352 AND ABOVE
55C	464216830	TRAVEL LEVER, LEFT .....	1	S/N 1352 AND ABOVE
56	464457400	HANDLE BOSS .....	1	S/N 1351 AND BELOW
57	012010030	BOLT 10X30.....	2	REPLACES 001221030
58	030210250	WASHER, LOCK M10	2	
59	467218900	HANDLE W/ RUBBER GRIP	1	
60	030210250	WASHER, LOCK M10	2	
61	031110160	WASHER, FLAT M10	2	
62	020310080	NUT M10	2	
63	0105091025	BOLT 10X25.....	2	REPLACES P/N 001221025
64	030210250	WASHER, LOCK M10	2	
67	467467380	THROTTLE LEVER	1	
68	959403840	BAR GRIP	1	
69	464457420	COVER, THROTTLE LEVER	1	
70	468467070	ARM, THROTTLE	1	
71	014208020	SOCKET HEAD BOLT 8X20.....	1	REPLACES P/N 001520820
72	0401450160	WASHER, FLAT M16 .....	1	REPLACES P/N 031116260
73	458450660	WASHER	2	
74	033910080	CONICAL WASHER, LOCK	3	
75	464457440	STEEL BALL	1	
76	464010010	DRY BUSHING	1	
77	011606025	BOLT 6X25.....	2	REPLACES P/N 001220625
78	020106050	NUT M6 .....	2	REPLACES P/N 020306050
80	464010020	ROD END M5	1	
81	001520520	SOCKET HEAD BOLT 5X20	1	
82	58151	WASHER, FLAT M5 .....	1	REPLACES P/N 031105080
83	020305040	NUT M5	1	
84	956100069	THROTTLE WIRE	1	
85	454010020	CLAMP	1	

**NAMEPLATE AND DECALS ASSY.**

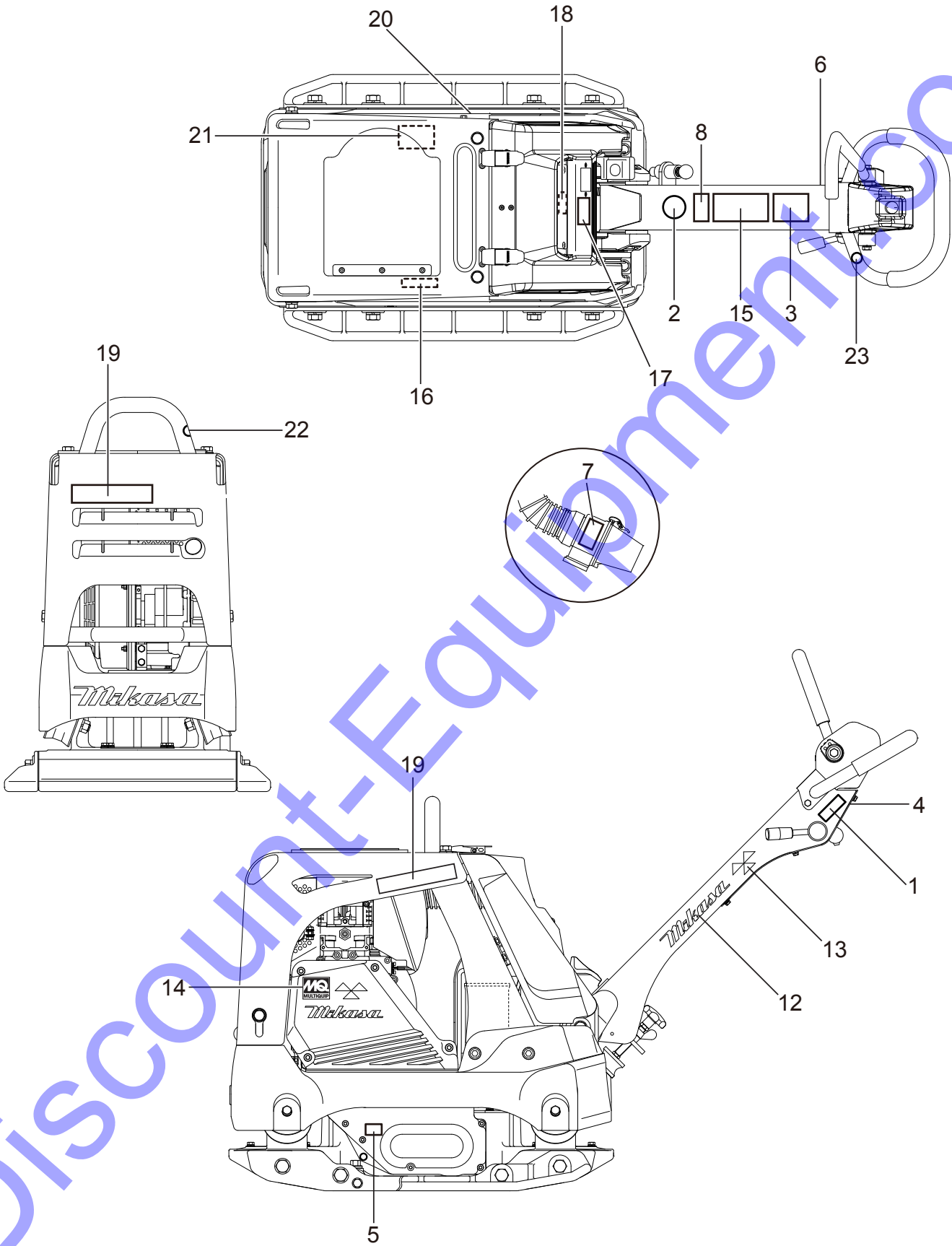

## NAMEPLATE AND DECALS ASSY.

<u>NO.</u>	<u>PART NO.</u>	<u>PART NAME</u>	<u>QTY.</u>	<u>REMARKS</u>
1	920204580	DECAL, FULL THROTTLE	1	
2	920203330	EAR PROTECTION LABEL	1	
3	920211060	DECAL, CAUTION LEVER	1	
4	920211090	DECAL, SHELL TELLUS OIL 32	1	
5	920201950	DECAL, OIL SAE 10W-30	1	
6	920106760	DECAL, STOP-RUN-START	1	
7	920214200	DECAL, CAUTION CYCLONE	1	
8	920214100	DECAL ,E/G FIRE WARNING	1	
12	920217130	DECAL, MIKASA MARK (W) 200L	2	
13	920217110	DECAL, MIKASA MARK 35X70	2	
14	920201580	DECAL, MQ MARK 71X55	1	
15	920218390	DECAL, CAUTION	1	
16	920217690	DECAL, V-BELT HDPF-5460	1	
17	920218150	DECAL, E/G RPM 2400	1	
18	920217880	DECAL, MODEL, MVH-408	1	
19	920217770	DECAL, MODEL (R)	2	
20	920217780	DECAL, MODEL (L)	1	
21		PLATE, SERIAL NO.....	1	CONTACT MQ PARTS DEPT.
22	920214740	DECAL, LIFTING POSITION	1	
23	920214730	DECAL, DO NOT LIFT	1	

# HATZ 1B50 ENGINE — SPARE PARTS KIT ASSY.

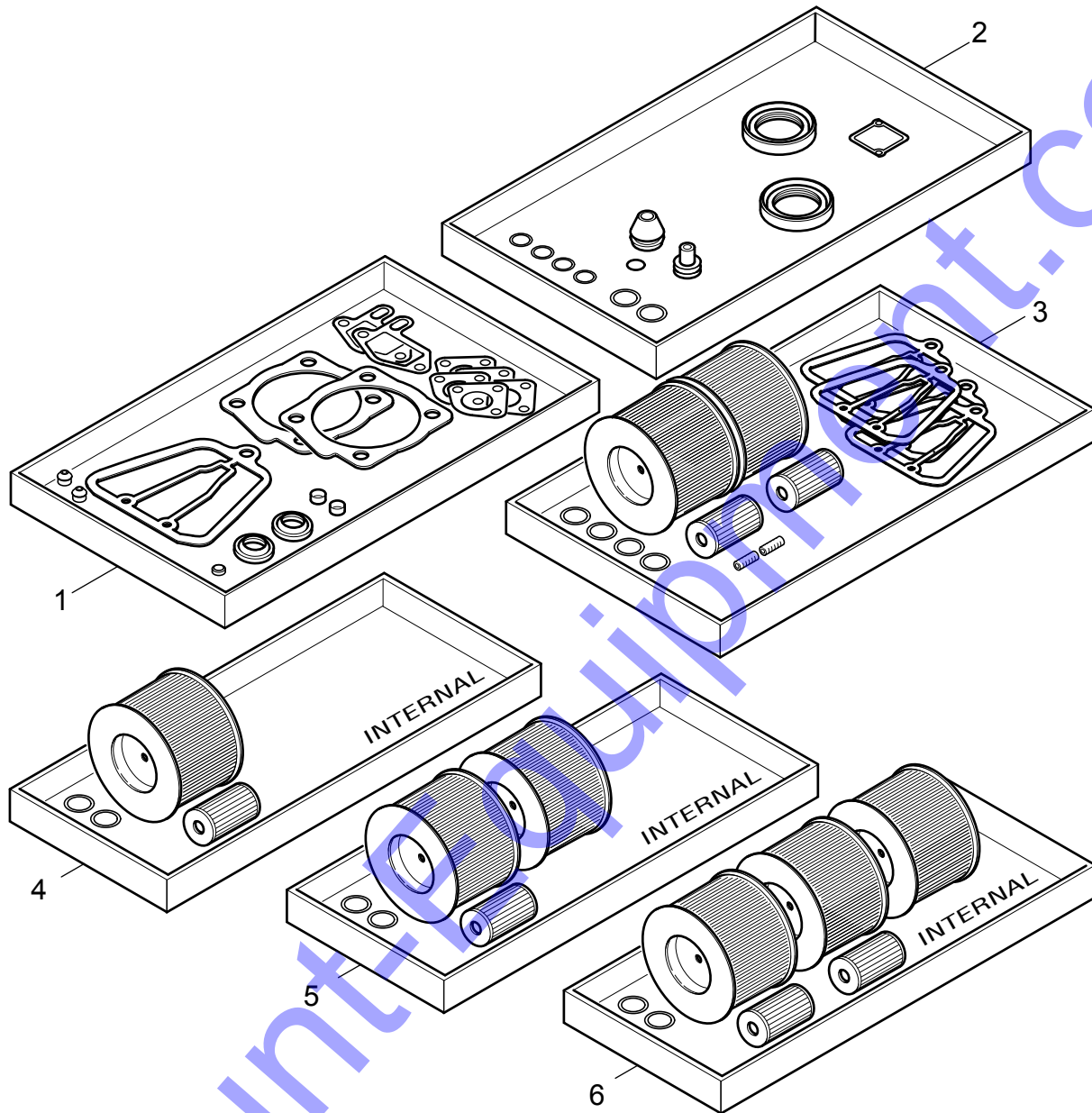

## HATZ 1B50 ENGINE — SPARE PARTS KIT ASSY.

<u>NO.</u>	<u>PART NO.</u>	<u>PART NAME</u>	<u>QTY.</u>	<u>REMARKS</u>
1	01940002	GASKET SET, CYLINDER HEAD	1	
2	01679303	GASKET SET, CRANKCASE	1	
3	01679400	MAINTENANCE KIT	1	
4	02265600	FILTER KIT/INT. LIGHT	1	
5	02268200	FILTER KIT/INT. MED.	1	
6	02269300	FILTER KIT/INT. HEAVY	1	

# HATZ 1B50 ENGINE — ACCESSORIES ASSY.

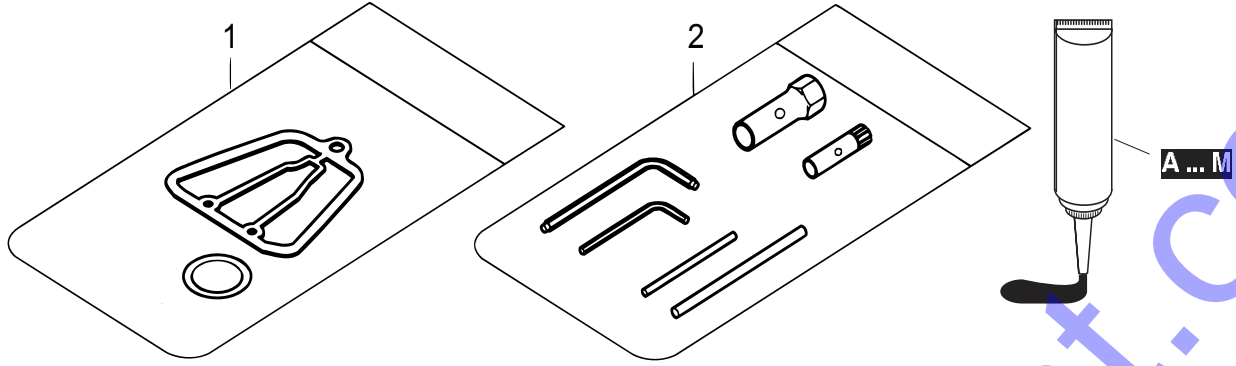

**HATZ**  
DIESEL

WARTUNG - MAINTENANCE  
ENTRETEN - MANTENIMIENTO  
MANUTENZIONE

8-15 250

STUNDEN - HOURS - HEURES  
HORAS - ORE

500

BEI BEDARF  
IF NECESSARY  
SI NECESSAIRE  
EN CASO DE  
NECESSARIO  
SE NECESSARIO

IN  
0.1 mm  
0.004 "

3

1B..

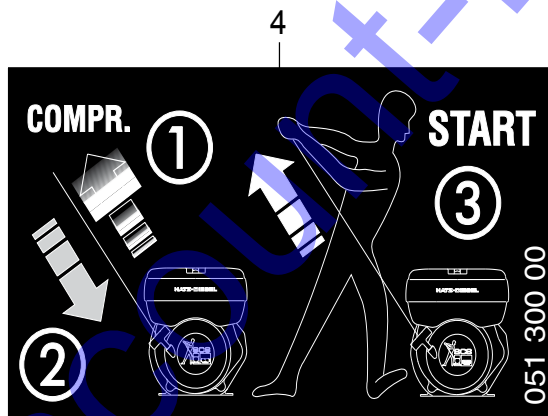

- |                         |                        |                            |
|-------------------------|------------------------|----------------------------|
| A                       | B                      | C                          |
| LOCTITE<br>ACTIVATOR N  | LOCTITE 574            | LOCTITE 601                |
| D                       | E                      | F                          |
| LOCTITE 221             | LOCTITE 648            | TECHNICAL<br>ADHESIVE 8058 |
| FA                      | G                      | H                          |
| TECHNICAL<br>CLEANER    | LOCTITE 407            | TEROSON<br>TEROSTAT 63     |
| J                       | K                      | L                          |
| HIGH TEMP.<br>PASTE     | HIGH TEMP<br>FETT 400G | SILICON<br>SEALER          |
| M                       |                        |                            |
| GRINDING<br>PASTE 80 ML |                        |                            |

## HATZ 1B50 ENGINE — ACCESSORIES ASSY.

<u>NO.</u>	<u>PART NO.</u>	<u>PART NAME</u>	<u>QTY.</u>	<u>REMARKS</u>
A	50223001	LOCTITE ACTIVATOR N	1	
B	50223101	LOCTITE 574	1	
C	50223200	LOCTITE 601	1	
D	50223300	LOCTITE 221	1	
E	50223400	LOCTITE 648	1	
F	50223800	TECHNICAL ADHESIVE 8058	1	
FA	50223900	TECHNICAL CLEANER	1	
G	50256501	LOCTITE IS 407	1	
H	70018944	TEROSON TEROSTAT 63	1	
J	50283004	HIGH TEMPERATURE PASTE	1	
K	50342601	HIGH TEMPERATURE FETT 400G	1	
L	50256600	SILICON SEALER	1	
M	50485100	GRINDING PASTE 80ML	1	
1	01329701	ACCESSORIES KIT	1	
2	01330901	TOOLS	1	
3	05110406	STICKER LABEL	1	
4	05130002	STICKER LABEL "START"	1	



# HATZ 1B50 ENGINE — CRANKCASE ASSY.

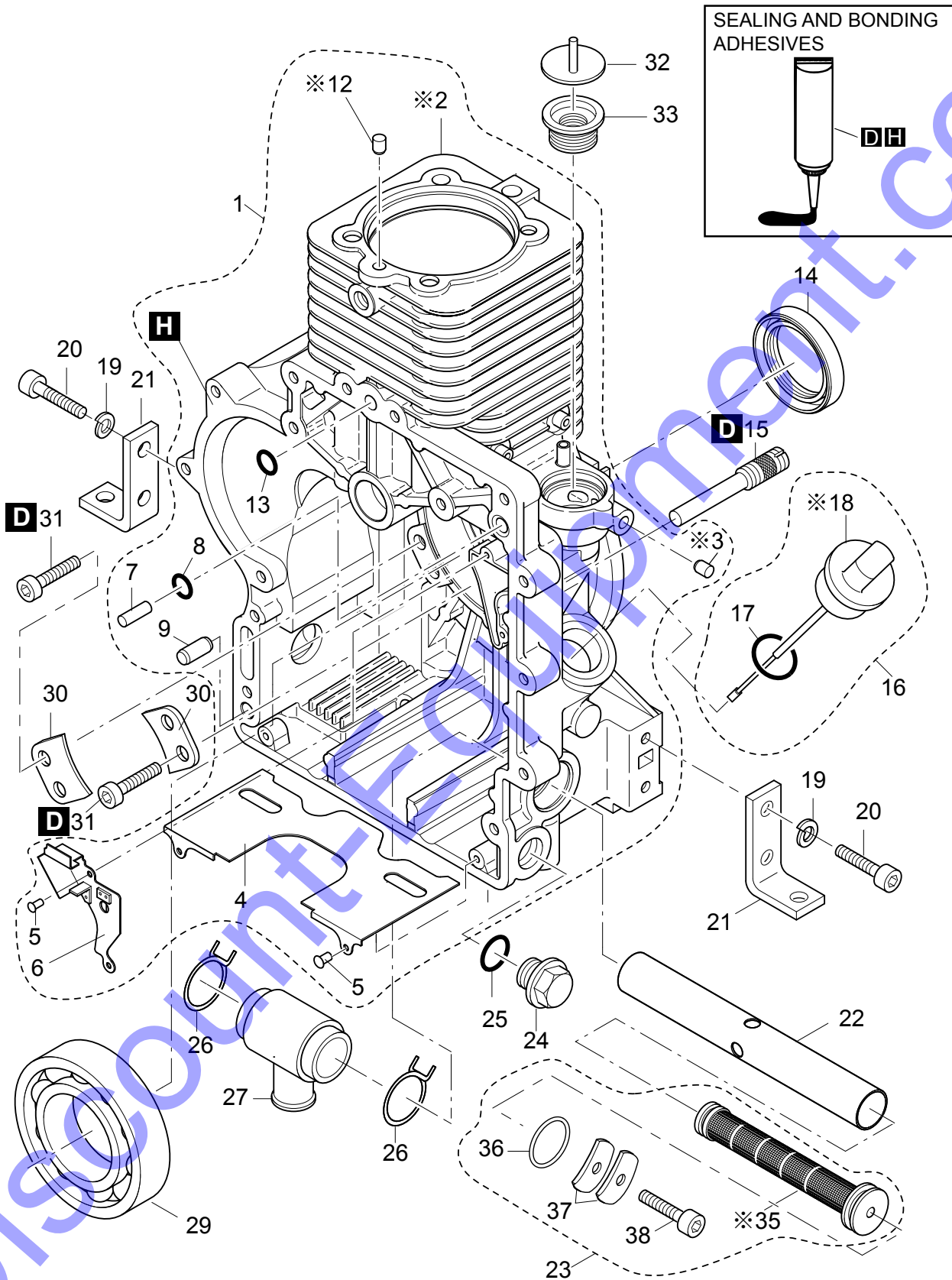

※ NOT SOLD SEPARATELY

## HATZ 1B50 ENGINE — CRANKCASE ASSY.

<u>NO.</u>	<u>PART NO.</u>	<u>PART NAME</u>	<u>QTY.</u>	<u>REMARKS</u>
D	50223300	LOCTITE 221	1	
H	70018944	TEROSON TEROSTAT 63	1	
1	01946500	CRANKCASE ASSY.....	1	INCLUDES ITEMS W/\$
2\$		CRANKCASE.....	1	NOT SOLD SEPARATELY
3\$		PLUG.....		NOT SOLD SEPARATELY
4\$	04141600	COVER SHEET	1	
5\$	40002600	BLIND RIVET	1	
6\$	01336410	COVER SHEET, SIDE	4	
7\$	50502801	CYLINDER PIN 8 M6X24	1	
8\$	50440300	O-RING 8X1.5	1	
9\$	50249102	Z-CYLINDER PIN 8 M6X20	1	
12\$		PLUG.....	2	NOT SOLD SEPARATELY
13\$	40022300	O-RING 8X2	1	
14	50479000	OIL SEAL 45X60X8	1	
15	04198800	GRUB SCREW CARB	1	
16	01342800	DIPSTICK ASSY. ....	1	INCLUDES ITEMS W/@
17@	04125000	SEALING RING, DIPSTICK	1	
18@		DIPSTICK.....	1	NOT SOLD SEPARATELY
19	50208500	WASHER, LOCK	8	
20	04219500	ALLEN SCREW M8X40	8	
21	04144701	ENGINE BRACKET	4	
22	04141500	TUBE, OIL FILTER	1	
23	01542703	OIL SUCTION FILTER ASSY.....	1	INCLUDES ITEMS W/#
24	50373100	DRAIN PLUG, MAGNETIC M22	1	
25	50001600	GASKET	1	
26	05036900	HOSE CLIP	2	
27	04163000	T-PIECE	1	
29	50478900	GROOVE BALL BEARING 6310	1	
30	04133800	PLATE	3	
31	50564200	ALLEN SCREW M6X18	6	
32	01555800	COVER	1	
33	03568701	OIL SUPPLEMENT PLUG	1	
35#		OIL SUCTION FILTER.....	1	NOT SOLD SEPARATELY
36#	50475901	O-RING 20X4	1	
37#	05148200	PLATE SPRING	2	
38#	50170700	ALLEN SCREW M6X16	1	

# HATZ 1B50 ENGINE — CRANKSHAFT ASSY.

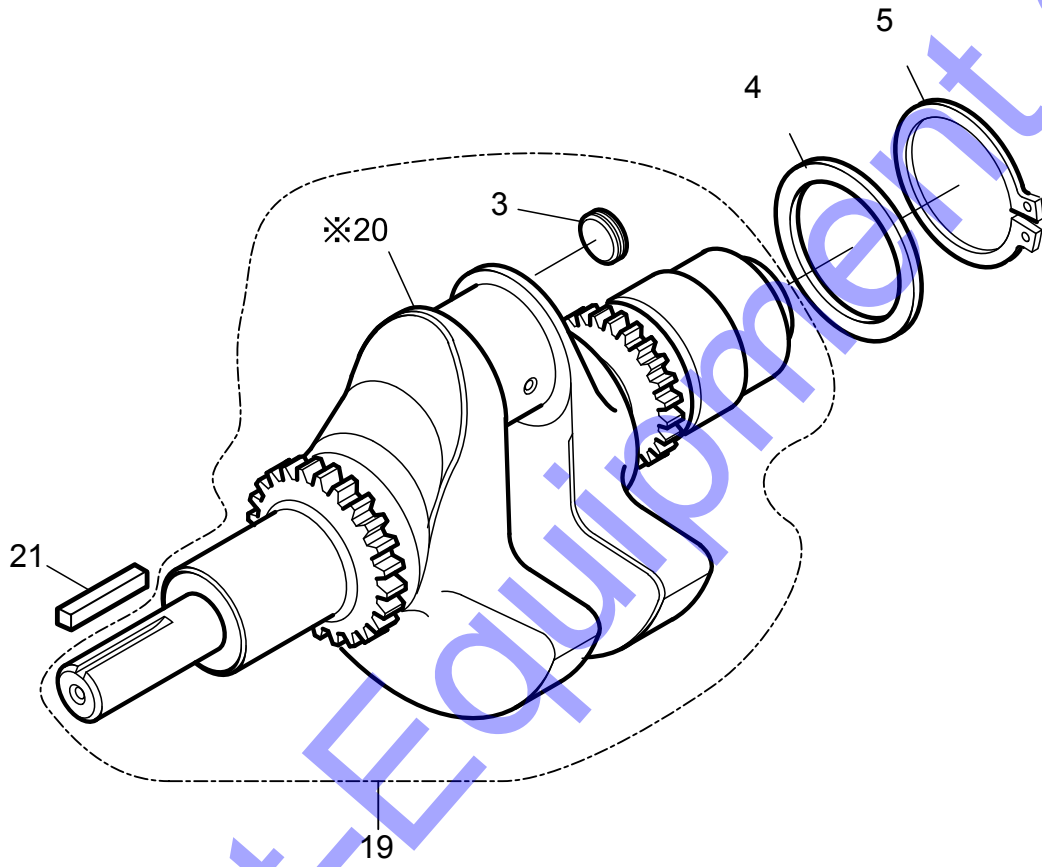

※ NOT SOLD SEPARATELY

## HATZ 1B50 ENGINE — CRANKSHAFT ASSY.

<u>NO.</u>	<u>PART NO.</u>	<u>PART NAME</u>	<u>QTY.</u>	<u>REMARKS</u>
3\$	50529700	COVER	1	
4	50481400	SUPPORTING DISC 50X62X3.0	1	
5	50021800	CIRCLIP 50X2	1	
19	01896210	CRANKSHAFT ASSY. ....	1.....	INCLUDES ITEMS W/\$
20\$		CRANKSHAFT.....	1.....	NOT SOLD SEPARATELY
21	05306100	KEY 7X7X35	1	

# HATZ 1B50 ENGINE — CAMSHAFT ASSY.

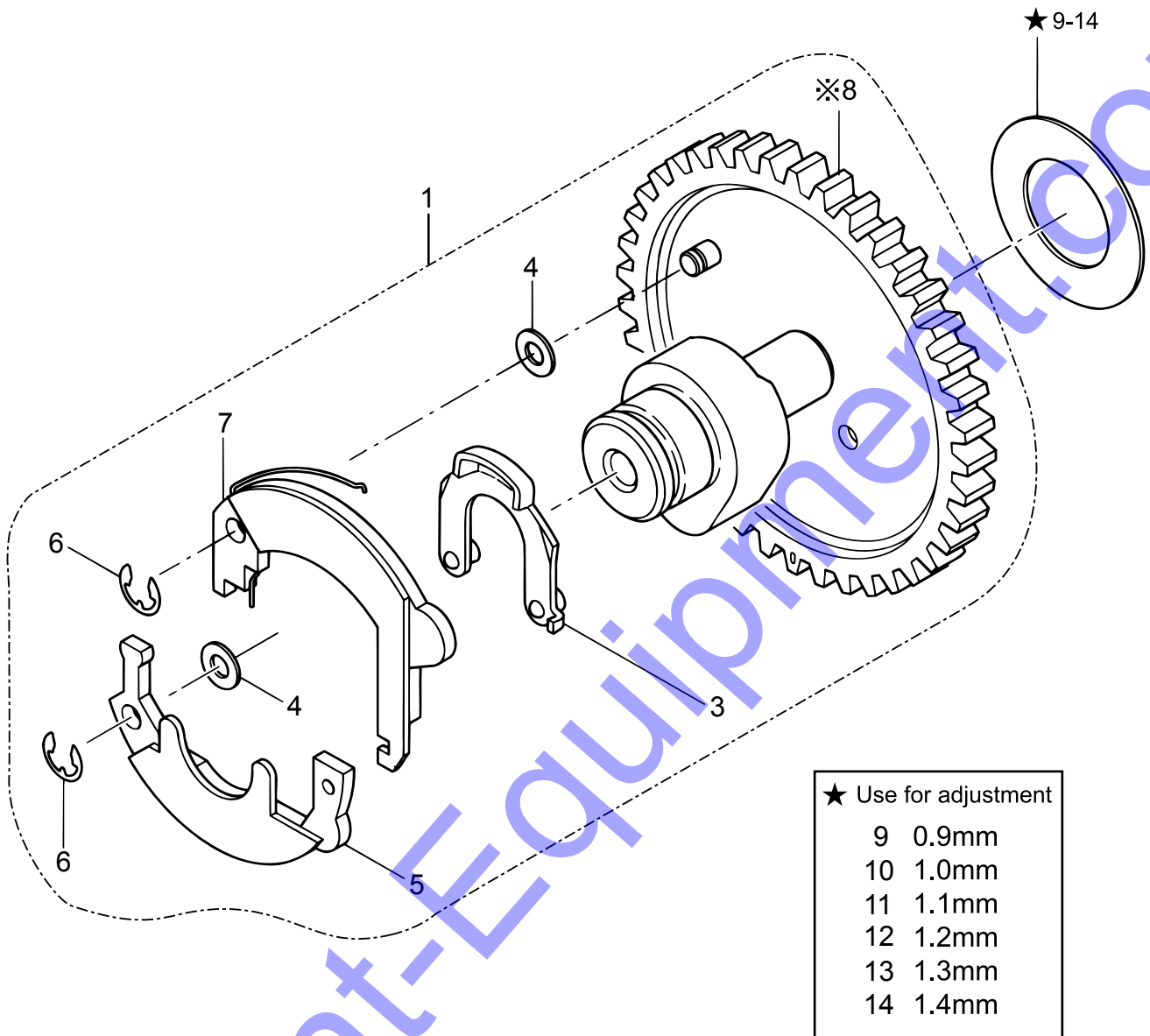

※ NOT SOLD SEPARATELY

## HATZ 1B50 ENGINE — CAMSHAFT ASSY.

<u>NO.</u>	<u>PART NO.</u>	<u>PART NAME</u>	<u>QTY.</u>	<u>REMARKS</u>
1	01345010	CAMSHAFT ASSY. ....	1.....	INCLUDES ITEMS W\$
3\$	01326401	CAMLEVER	1	
4\$	50123200	SHIM 5X10X0.5	1	
5\$	01326600	FLYWEIGHT	1	
6\$	50255300	WASHER, LOCK	1	
7\$	01326501	FLYWEIGHT HAND-START	1	
9	04121700	SHIM 23X38X0.9 .....	1.....	SELECT 0-1
10	04112100	SHIM 23X38X1.0 .....	1.....	SELECT 0-1
11	04112200	SHIM 23X38X1.1 .....	1.....	SELECT 0-1
12	04112300	SHIM 23X38X1.2 .....	1.....	SELECT 0-1
13	04125100	SHIM 23X38X1.3 .....	1.....	SELECT 0-1
14	04125200	SHIM 23X38X1.4 .....	1.....	SELECT 0-1

# HATZ 1B50 ENGINE — PISTON, CONROD, CYLINDER ASSY.

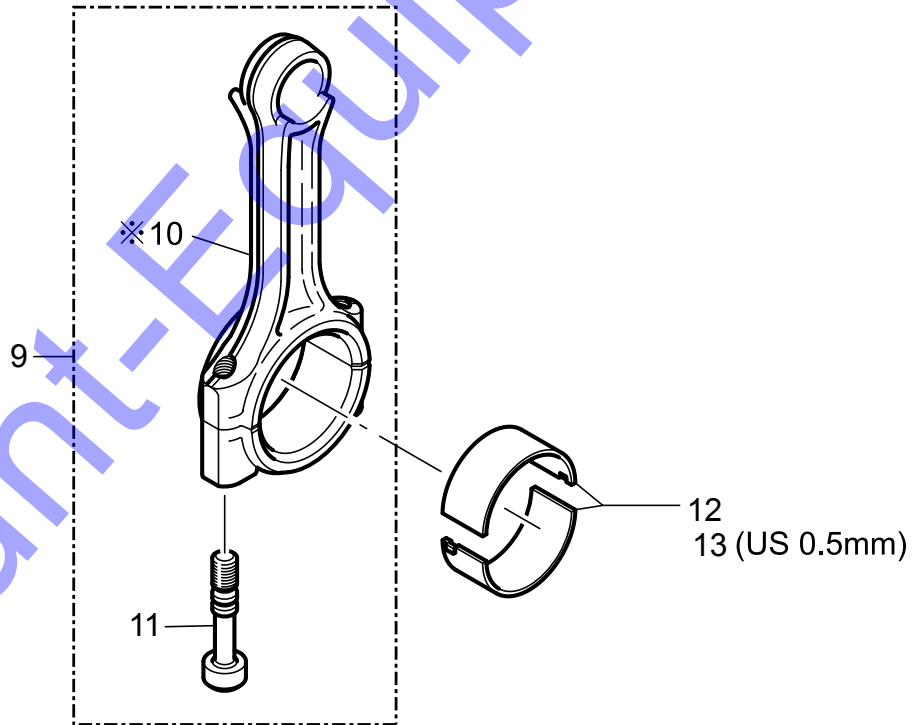
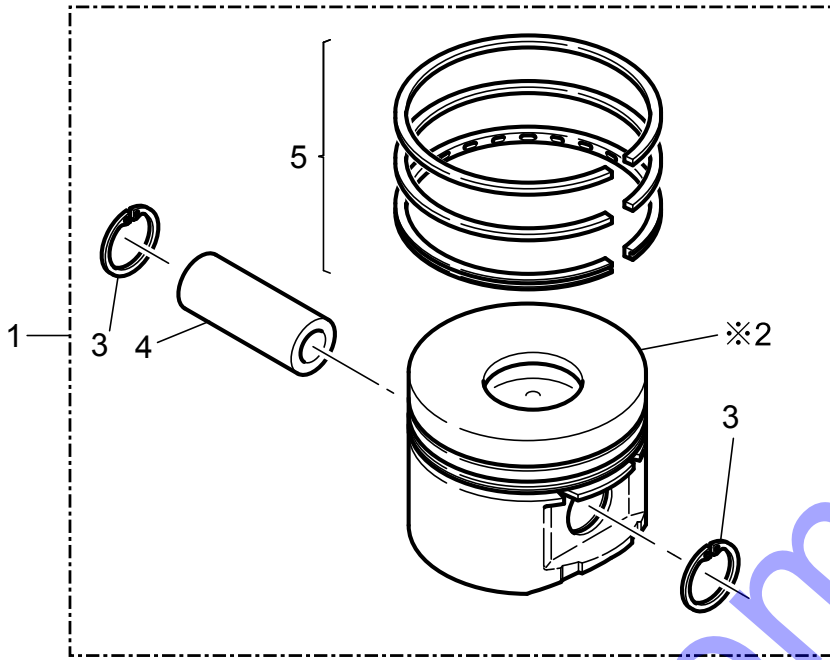

※ NOT SOLD SEPARATELY

## HATZ 1B50 ENGINE — PISTON, CONROD, CYLINDER ASSY.

<u>NO.</u>	<u>PART NO.</u>	<u>PART NAME</u>	<u>QTY.</u>	<u>REMARKS</u>
1	01384320	PISTON ASSY. 93MM .....	1.....	INCLUDES ITEMS W/\$
2\$		PISTON.....	1.....	NOT SOLD SEPARATELY
3\$	50482300	CIRCLIP 22X1	2	
4\$	50566400	GUDGEON PIN 22X13X60	1	
5\$	01384410	PISTON RING SET 93MM	1	
9	01343500	CONNECTING ROD ASSY.....	1.....	INCLUDES ITEMS W/%
10%		CONNECTING ROD.....		NOT SOLD SEPARATELY
11%	04100500	SCREW, CONNECTING ROD	2	
12	01679800	BIG END BEARING	1	
13	01692700	BIG END BEARING US -0.5	1	



# HATZ 1B50 ENGINE — CYLINDER HEAD ASSY.

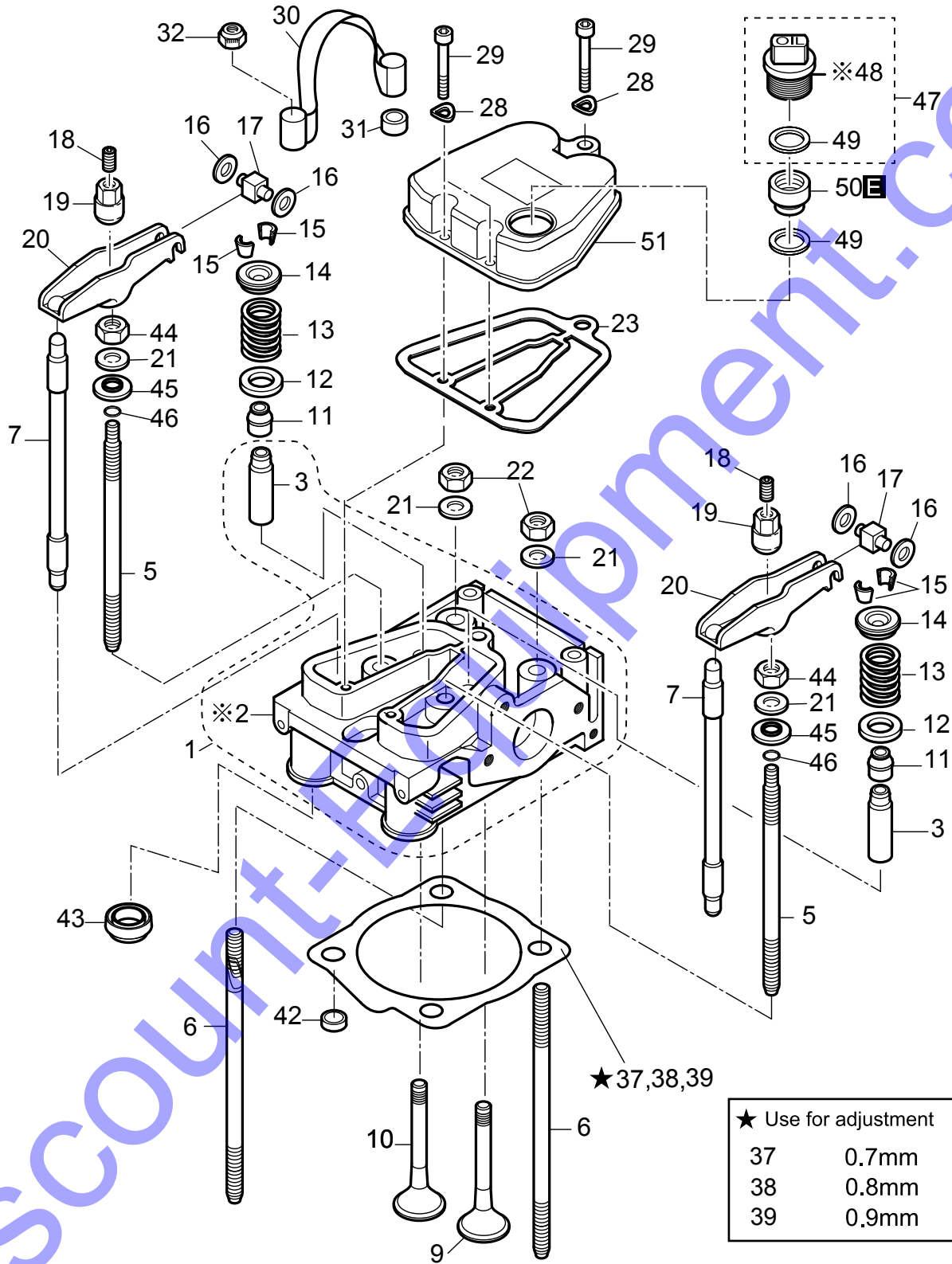

※ NOT SOLD SEPARATELY

## HATZ 1B50 ENGINE — CYLINDER HEAD ASSY.

<u>NO.</u>	<u>PART NO.</u>	<u>PART NAME</u>	<u>QTY.</u>	<u>REMARKS</u>
E	50223400	LOCTITE 648	1	
1	01850902	CYLINDER HEAD ASSY.....	1	INCLUDES ITEMS W/\$
2\$		CYLINDER HEAD.....	1	NOT SOLD SEPARATELY
3\$	05209700	VALVE GUIDE	2	
5	04253010	STUD CYLINDER HEAD	2	
6	04253110	STUD CYLINDER HEAD	2	
7	01374000	PUSHROD	2	
9	05145100	VALVE, INLET	1	
10	05145200	VALVE EXHAUST	1	
11	50631000	VALVE STEM SEAL CAP	2	
12	04147100	WASHER	2	
13	04146900	VALVE SPRING	2	
14	04147000	SPRING PLATE/RETAINER	2	
15	02252500	COLLET (COTTER)	2	
16	50445100	SUPPORT DISC 6X12X1.2	1	
17	05091101	SLIDER	2	
18	50513100	GRUB SCREW M8X10	2	
19	05054700	NUT, ROCKER ARM	2	
20	05146701	ROCKER ARM	2	
21	05099300	WASHER 10.1X24X3	4	
22	50396600	HEXAGON NUT M10	2	
23	05156401	GASKET, CYLINDER HEAD	1	
28	50081200	WASHER, LOCK A6	3	
29	50374900	ALLEN SCREW M6X35	3	
30	04117701	LIFTING STRAP	1	
31	04126100	PROTECTION HOSE	2	
32	40028600	HEXAGON NUT M10	2	
37	04235230	GASKET, CYLINDER HEAD 0.7	1	
38	04235330	GASKET, CYLINDER HEAD 0.8	1	
39	04235430	GASKET, CYLINDER HEAD 0.9	1	
42	04174500	CENTER BUSHING	2	
43	04106501	SEALING RING, TIMING COVER	2	
44	50396600	HEXAGON NUT M10	2	
45	04243700	DISC 8.1X12X2.0	2	
46	50563900	O-RING 10X2.5	2	
47	01936500	CAP SCREW, CYL. HD. COVER .....	1	INCLUDES ITEMS W/%
48%		CAP SCREW .....	1	NOT SOLD SEPARATELY
49%	05278401	SEALING RING 26X35X4	2	
50	05321100	CONNECTING PIECE	1	
51	05256800	COVER CYLINDER HEAD/F. CAP	1	

# HATZ 1B50 ENGINE — OIL PUMP, GOVERNOR ASSY.

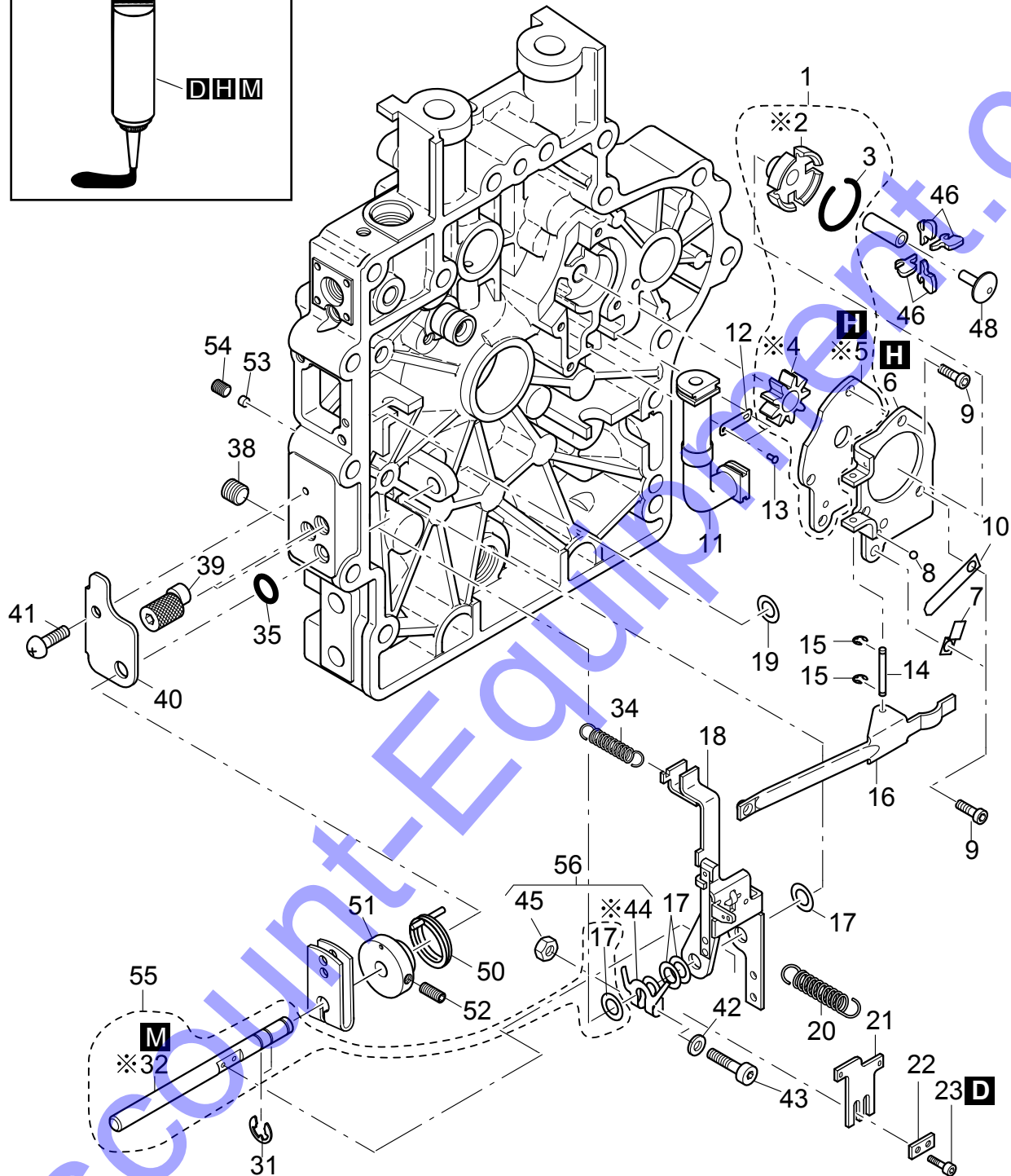
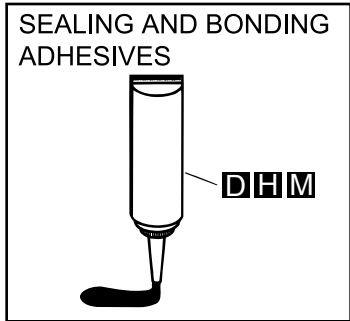

## HATZ 1B50 ENGINE — OIL PUMP, GOVERNOR ASSY.

<u>NO.</u>	<u>PART NO.</u>	<u>PART NAME</u>	<u>QTY.</u>	<u>REMARKS</u>
D	50223300	LOCTITE 221	1	
H	70018944	TEROSON TEROSTAT 63	1	
M	50485100	GRINDING PASTE 80ML	1	
1	01344510	OIL PUMP ASSY. ....	1	INCLUDES ITEMS W/\$
2\$		HOUSING, OIL PUMP .....	1	NOT SOLD SEPARATELY
3\$	04210910	CIRCLIP	1	
4\$		GEAR, OIL PUMP.....	1	NOT SOLD SEPARATELY
5\$		SPACER, OIL PUMP .....	1	NOT SOLD SEPARATELY
6	05078110	COVER, OIL PUMP	1	
7	05097100	RETAINING STRAP	1	
8	50447900	BALL 3.5MM	1	
9	50429400	ALLEN SCREW M5X12	4	
10	05097300	FLAT SPRING 0.4	1	
11	01346000	TUBE, OIL SUCTION	1	
12	04153400	FISHPLATE	1	
13	40002600	BLIND RIVET 3.2 K44311	2	
14	05078600	SHAFT	1	
15	50434800	CIRCLIP 1.9	2	
16	04208300	LEVER	1	
17%	50422400	SHIM 8X14X1	2	
18	01530404	GOVERNOR LEVER	1	
19	50125800	DISC 8X14X0.5	1	
20	04290100	GOVERNOR SPRING .....	1	SELECT 0-1
21	05130800	STOP	1	
22	05079800	INTERMEDIATE PLATE .....	1	SELECT 1-5
23	50465300	ALLEN SCREW M3X8	2	
31	50092700	CIRCLIP 7	4	
32%		SHAFT .....	1	NOT SOLD SEPARATELY
34	50563400	TENSION SPRING .....	1	SELECT 0-1
34A	04000200	TENSION SPRING .....	1	SELECT 0-1
35	40022401	O-RING 8X2 GRAY	1	
38	50475700	GRUB SCREW M10X10	1	
39	05178810	ECCENTRIC SCREW	2	
40	05178400	PLATE	1	
41	50492300	FILLISTER HEAD SCREW M5X12	1	
42	50216300	WASHER 5.3	1	
43	50492200	ALLEN SCREW M5X25	1	
44#		STOP .....	1	NOT SOLD SEPARATELY
45#	50094300	HEXAGON NUT M5	1	
46	05079611	CENTRIFUGAL WEIGHT .....	1	SELECT 0-4
48	05078502	GOVERNOR SLEEVE	1	
50	05154010	SPRING .....	1	SELECT 0-1
51	05179000	BUSH .....	1	SELECT 0-1
52	50400600	GRUB SCREW M5X10 .....	1	SELECT 0-1
53	05307300	PLUG 4.5X3	1	
54	50574600	THREADED PIN M6X10	1	
55	01981000	SHAFT W/ SHIMS .....	1	INCLUDES ITEM W/%
56	02340300	STOP W/ NUT .....	1	INCLUDES ITEM W/#

# HATZ 1B50 ENGINE — TIMING COVER ASSY.

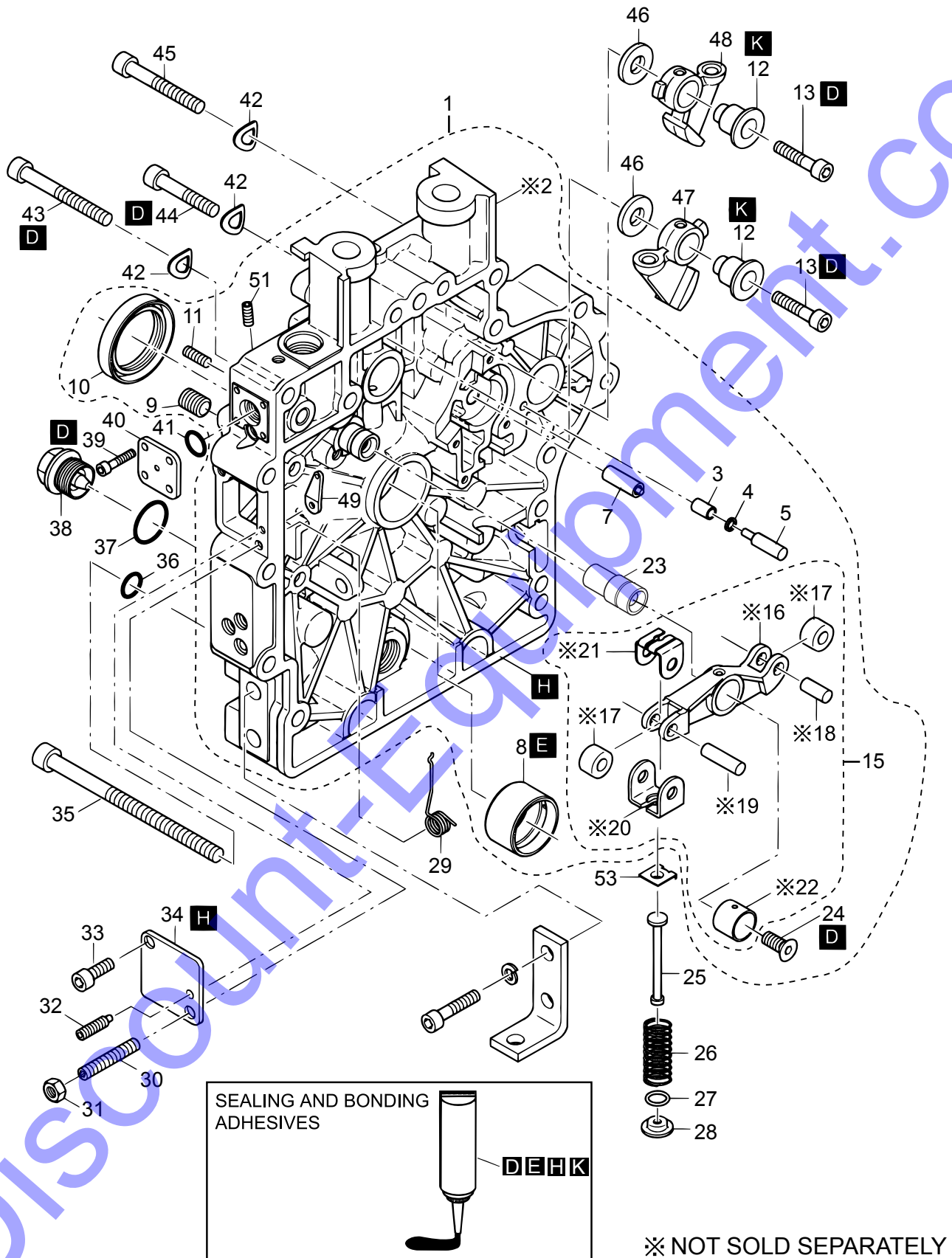

## HATZ 1B50 ENGINE — TIMING COVER ASSY.

NO.	PART NO.	PART NAME	QTY.	REMARKS
D	50223300	LOCTITE 221	1	
E	50223400	LOCTITE 648	1	
H	70018944	TEROSON TEROSTAT 63	1	
K	50342601	HIGH TEMPERATURE FETT 400G	1	
1	02262600	TIMING COVER ASSY. ....	1	INCLUDES ITEMS W/\$
2\$		TIMING COVER.....	1	NOT SOLD SEPARATELY
3\$	04185800	CLOSING PLUG	1	
4\$	50464100	O-RING 2X1	1	
5\$	04185700	CLOSING PLUG 4X15	1	
7\$	01344600	BOLT, GOVERNOR HOUSING	1	
8\$	04148801	MAIN BEARING, STANDARD	1	
8	04220801	MAIN BEARING, US -0.5	1	
9\$	50530600	GRUB SCREW M8X10	4	
10\$	50479500	OIL SEAL 35X47X7	1	
11\$	50400600	GRUB SCREW M5X10	2	
12	03794201	CAM FOLLOW SPINDLE	2	
13	50457900	ALLEN SCREW M6X25	2	
15\$	01346720	ROCKER LEVER ASSY.....	1	INCLUDES ITEMS W/%
16%		ROCKER LEVER.....	1	NOT SOLD SEPARATELY
17%		BUSHING.....	2	NOT SOLD SEPARATELY
18%		BOLT, ROCKER LEVER .....	1	NOT SOLD SEPARATELY
19%		BOLT, ROCKER LEVER .....	1	NOT SOLD SEPARATELY
20%		CLAMP, LOWER .....	1	NOT SOLD SEPARATELY
21%		CLAMP, UPPER.....	1	NOT SOLD SEPARATELY
22%		BUSHING.....	1	NOT SOLD SEPARATELY
23\$	04096830	CAM FOLLOW SPINDLE	1	
24\$	50561800	COUNTERSUNK SCREW M6X40	1	
25	04094700	DRAW ROD	1	
26	04095700	PRESSURE SPRING	1	
27	04133900	DISC 10.7X19X0.5	1	
28	04094802	CUP	1	
29	05095210	SPRING, GOVERNOR	1	
30	50499300	GRUB SCREW M6X35	1	
31	020106050	HEXAGON NUT M6.....	1	REPLACES P/N 50144400
32	50499400	GRUB SCREW M4X25	1	
33	50384200	ALLEN SCREW M6X12	1	
34	04095210	COVER	1	
35	50463000	ALLEN SCREW M8X130	2	
36	50162900	JOINT A8X14	2	
37	50001600	GASKET	1	
38	50373100	DRAIN PLUG MAGNT. M22	1	
39	50397100	ALLEN SCREW M4X10	4	
40	01351700	COVER	1	

# HATZ 1B50 ENGINE — TIMING COVER ASSY. (CONTINUED)

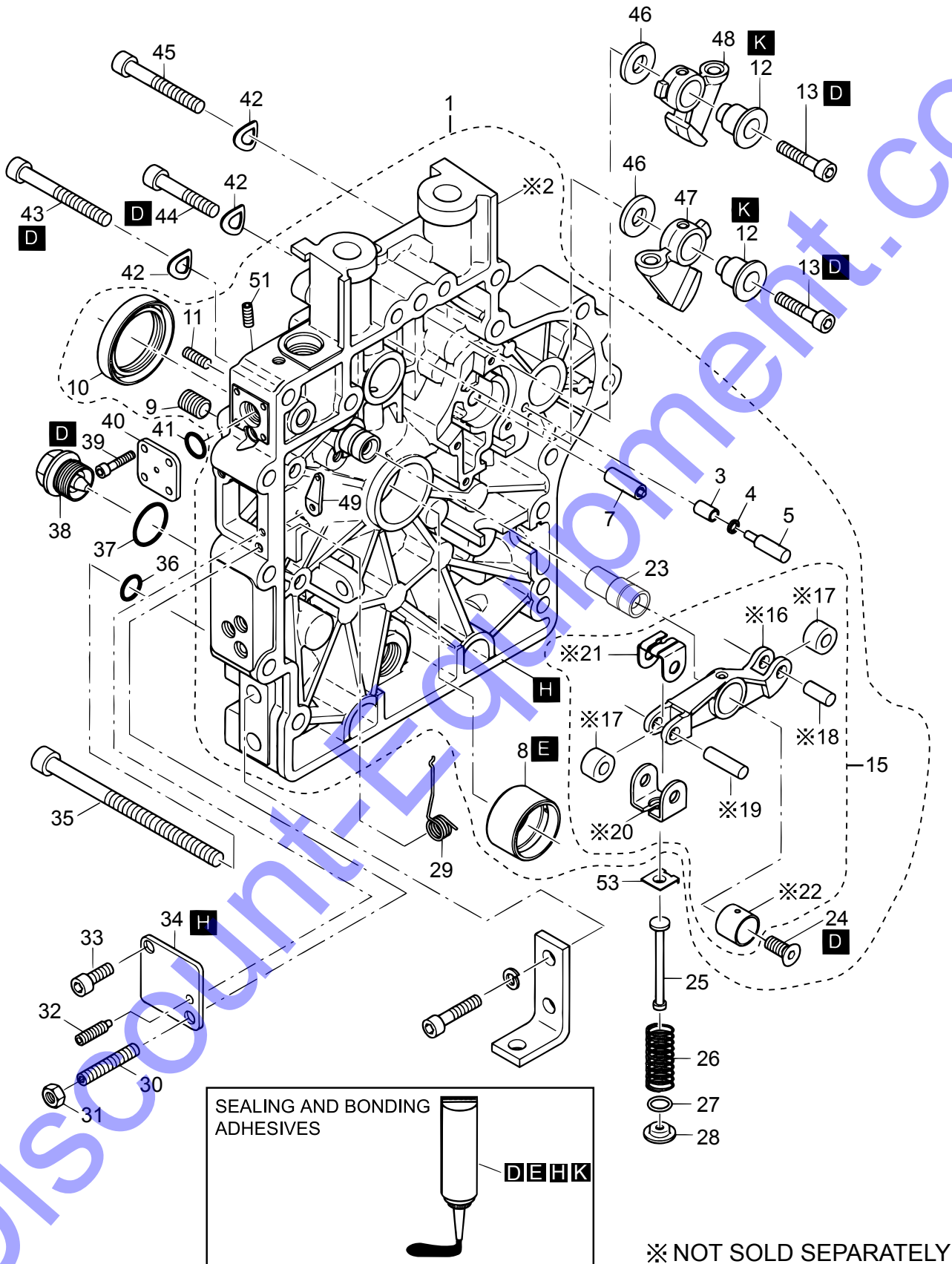

## HATZ 1B50 ENGINE — TIMING COVER ASSY. (CONTINUED)

<u>NO.</u>	<u>PART NO.</u>	<u>PART NAME</u>	<u>QTY.</u>	<u>REMARKS</u>
41	50329000	O-RING 9.5X2.5	1	
42	50095100	WASHER, LOCK A8	15	
43	50288800	ALLEN SCREW M8X55	11	
44	50177500	ALLEN SCREW M8X40	2	
45	50392900	ALLEN SCREW M8X50	2	
46	03794100	WASHER	2	
47	04146600	CAM FOLLOWER	1	
48	04146000	CAM FOLLOWER	1	
49	05127100	LEVER	1	
51	50262400	THREADED PIN M6X10	1	
53	04189500	CUP	1	



# HATZ 1B50 ENGINE — BLOWER, FLYWHEEL ASSY.

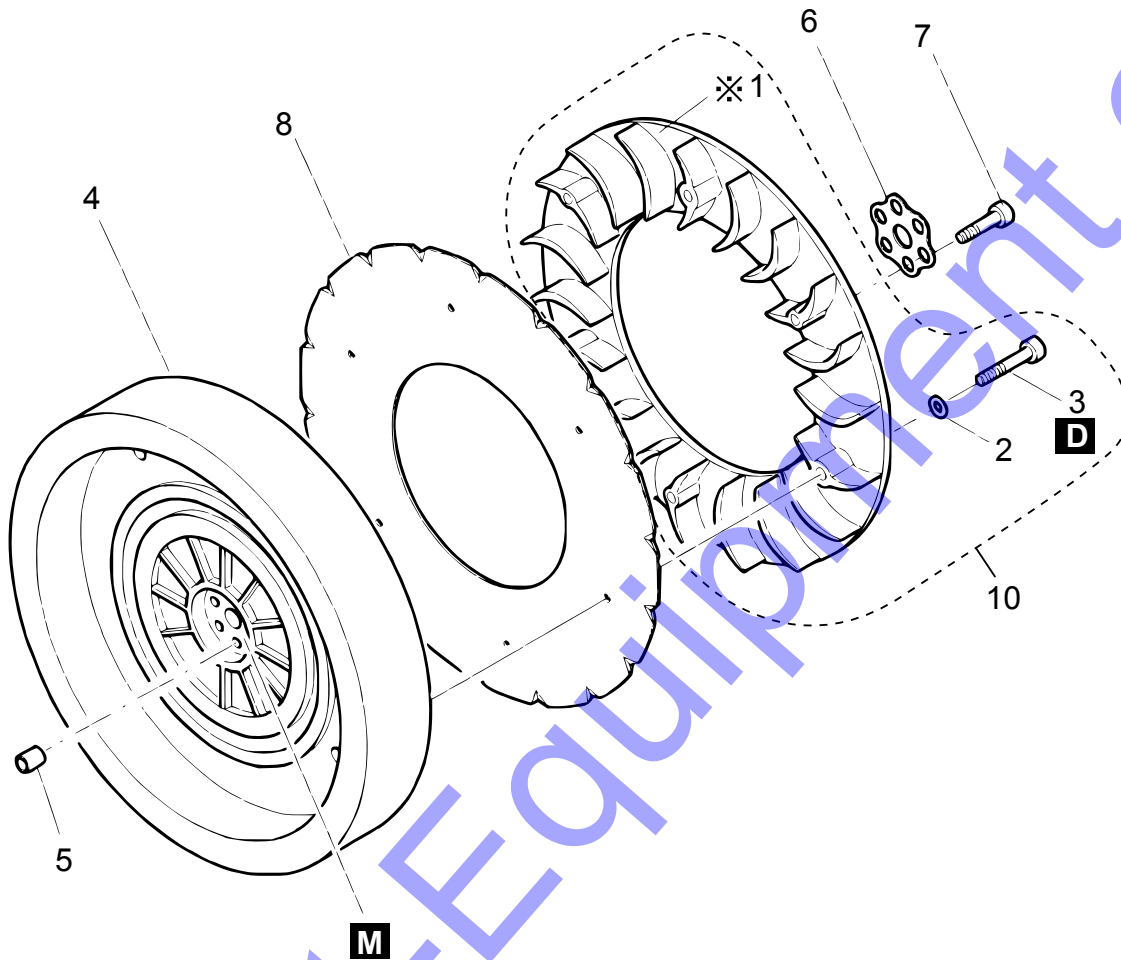

## HATZ 1B50 ENGINE — BLOWER, FLYWHEEL ASSY.

<u>NO.</u>	<u>PART NO.</u>	<u>PART NAME</u>	<u>QTY.</u>	<u>REMARKS</u>
D	50223300	LOCTITE 221	1	
M	50485100	GRINDING PASTE 80ML	1	
1\$		BLOWER RING .....	1	NOT SOLD SEPARATELY
2\$	50003400	WASHER, LOCK A4	6	
3\$	50327300	ALLEN SCREW M4X20	6	
4	04234700	FLYWHEEL	1	
5	04288200	BUSH	1	
6	04155101	PLATE	1	
7	50502501	ALLEN SCREW M8X35	6	
8	01390800	PLATE	1	
10	01934300	BLOWER RING W/ WASHER AND SCREW.....	1	INCLUDES ITEMS W/\$

# HATZ 1B50 ENGINE — INJECTION EQUIPMENT ASSY.

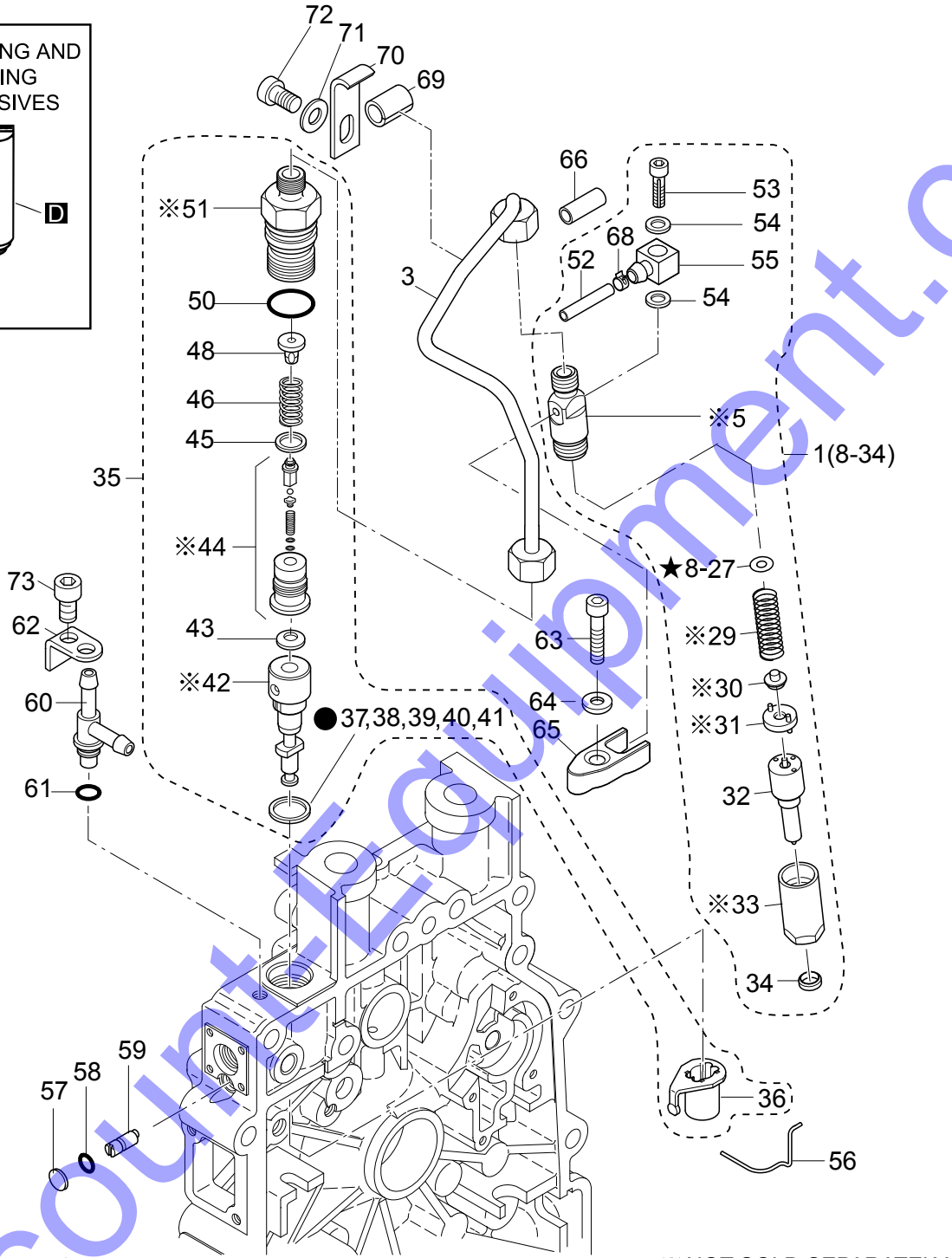
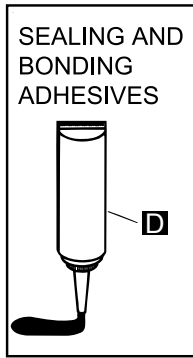

● Use for adjustment

37	0.2mm
38	0.3mm
39	0.4mm
40	0.5mm
41	0.6mm

★ Use for adjustment

8	1.00mm	13	1.24mm	18	1.50mm	23	1.74mm
9	1.04mm	14	1.30mm	19	1.54mm	24	1.80mm
10	1.10mm	15	1.34mm	20	1.60mm	25	1.84mm
11	1.14mm	16	1.40mm	21	1.64mm	26	1.90mm
12	1.20mm	17	1.44mm	22	1.70mm	27	1.94mm

## HATZ 1B50 ENGINE — INJECTION EQUIPMENT ASSY.

<u>NO.</u>	<u>PART NO.</u>	<u>PART NAME</u>	<u>QTY.</u>	<u>REMARKS</u>
D	50223300	LOCTITE 221	1	
1	01399510	INJECTOR ASSY. ....	1	INCLUDES ITEMS W/\$
3	02022901	FUEL PRESSURE PIPE	1	
5\$		HOUSING, INJECTOR .....	1	NOT SOLD SEPARATELY
8\$	50436400	SHIM 1.0 .....	1	SELECT 0-1
9	50436500	SHIM 1.04 .....	1	SELECT 0-1
10	50436600	SHIM 1.10 .....	1	SELECT 0-1
11	50436700	SHIM 1.14 .....	1	SELECT 0-1
12	50436800	SHIM 1.20 .....	1	SELECT 0-1
13	50436900	SHIM 1.24 .....	1	SELECT 0-1
14	50437000	SHIM 1.30 .....	1	SELECT 0-1
15	50437100	SHIM 1.34 .....	1	SELECT 0-1
16	50437200	SHIM 1.40 .....	1	SELECT 0-1
17	50437300	SHIM 1.44 .....	1	SELECT 0-1
18	50437400	SHIM 1.50 .....	1	SELECT 0-1
19	50437500	SHIM 1.54 .....	1	SELECT 0-1
20	50437600	SHIM 1.60 .....	1	SELECT 0-1
21	50437700	SHIM 1.64 .....	1	SELECT 0-1
22	50437800	SHIM 1.70 .....	1	SELECT 0-1
23	50437900	SHIM 1.74 .....	1	SELECT 0-1
24	50438000	SHIM 1.80 .....	1	SELECT 0-1
25	50438100	SHIM 1.84 .....	1	SELECT 0-1
26	50438200	SHIM 1.90 .....	1	SELECT 0-1
27	50438300	SHIM 1.94 .....	1	SELECT 0-1
29\$		SPRING, INJECTOR .....	1	NOT SOLD SEPARATELY
30\$		GUIDE, INJECTOR SPRING .....	1	NOT SOLD SEPARATELY
31\$		HOLDER, GUIDE .....	1	NOT SOLD SEPARATELY
32\$	50577410	NOZZLE	1	
33\$		BODY, INJECTOR .....	1	NOT SOLD SEPARATELY
34\$	05070500	JOINT WASHER INJECTOR	1	
35	01680820	INJECTION PUMP ASSY. ....	1	INCLUDES ITEMS W/%
36%	01330801	CONTROL SLEEVE	1	
37%	04096300	SHIM 14X18X0.2 .....	1	SELECT 0-1
38	04096400	SHIM 14X18X0.3 .....	1	SELECT 0-1
39	04096500	SHIM 14X18X0.4 .....	1	SELECT 0-1
40	04096600	SHIM 14X18X0.5 .....	1	SELECT 0-1
41	04096700	SHIM 14X18X0.6 .....	1	SELECT 0-1
42%		VALVE, INJECTION PUMP .....	1	NOT SOLD SEPARATELY

# HATZ 1B50 ENGINE — INJECTION EQUIPMENT ASSY. (CONTINUED)

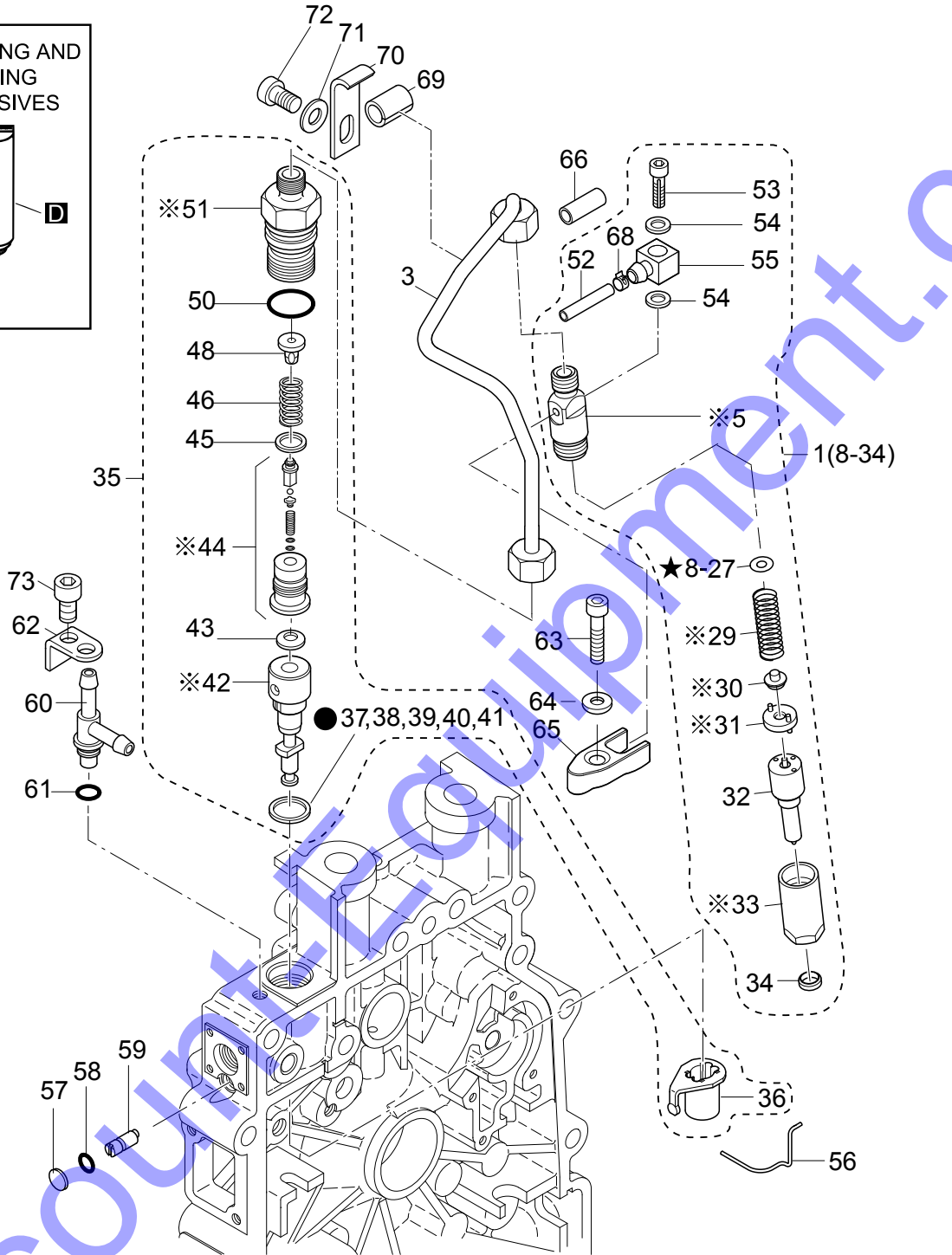
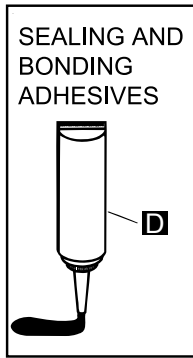

※ NOT SOLD SEPARATELY

● Use for adjustment	
37	0.2mm
38	0.3mm
39	0.4mm
40	0.5mm
41	0.6mm

★ Use for adjustment			
8	1.00mm	13	1.24mm
9	1.04mm	14	1.30mm
10	1.10mm	15	1.34mm
11	1.14mm	16	1.40mm
12	1.20mm	17	1.44mm
18	1.50mm	23	1.74mm
19	1.54mm	24	1.80mm
20	1.60mm	25	1.84mm
21	1.64mm	26	1.90mm
22	1.70mm	27	1.94mm

## HATZ 1B50 ENGINE — INJECTION EQUIPMENT ASSY. (CONTINUED)

<u>NO.</u>	<u>PART NO.</u>	<u>PART NAME</u>	<u>QTY.</u>	<u>REMARKS</u>
43%	04165200	SEALING WASHER	1	
44%		VALVE COMPONENTS .....	1	NOT SOLD SEPARATELY
45%	50476900	JOINT WASHER	1	
50%	50489200	O-RING 17X2	1	
51%		HOUSING, INJECTION PUMP.....	1	NOT SOLD SEPARATELY
52\$	04282000	HOSE 2.5X245	1	
53\$	04281900	ALLEN SCREW M4X14	1	
54\$	50110800	JOINT A 4X8	2	
55\$	05129000	CONNECTING NIPPLE	1	
56	04161800	HOLDING SPRING	1	
57	50476000	DISC	1	
58	50330100	O-RING 4X1.2	1	
59	04097710	ECCENTRIC PIN	1	
60	01756800	NIPPLE	1	
61	50154300	O-RING 7.5X10.5X1.5	1	
62	05390700	SUPPORT	1	
63	50323900	ALLEN SCREW M6X30	1	
64	50596500	BALL DISC	1	
65	04281801	FORK, INJECTOR	1	
66	05267901	INSULATION HOSE 185MM	1	
68\$	50577900	CLAMP	1	
69	04282700	PROTECTION HOSE	1	
70	04282600	SUPPORT	1	
71	50144500	WASHER, FLAT 6.4	1	
72	50528100	ALLEN SCREW M6X16	1	
73	50547000	ALLEN SCREW M5X25	1	

# HATZ 1B50 ENGINE — RECOIL STARTER ASSY.

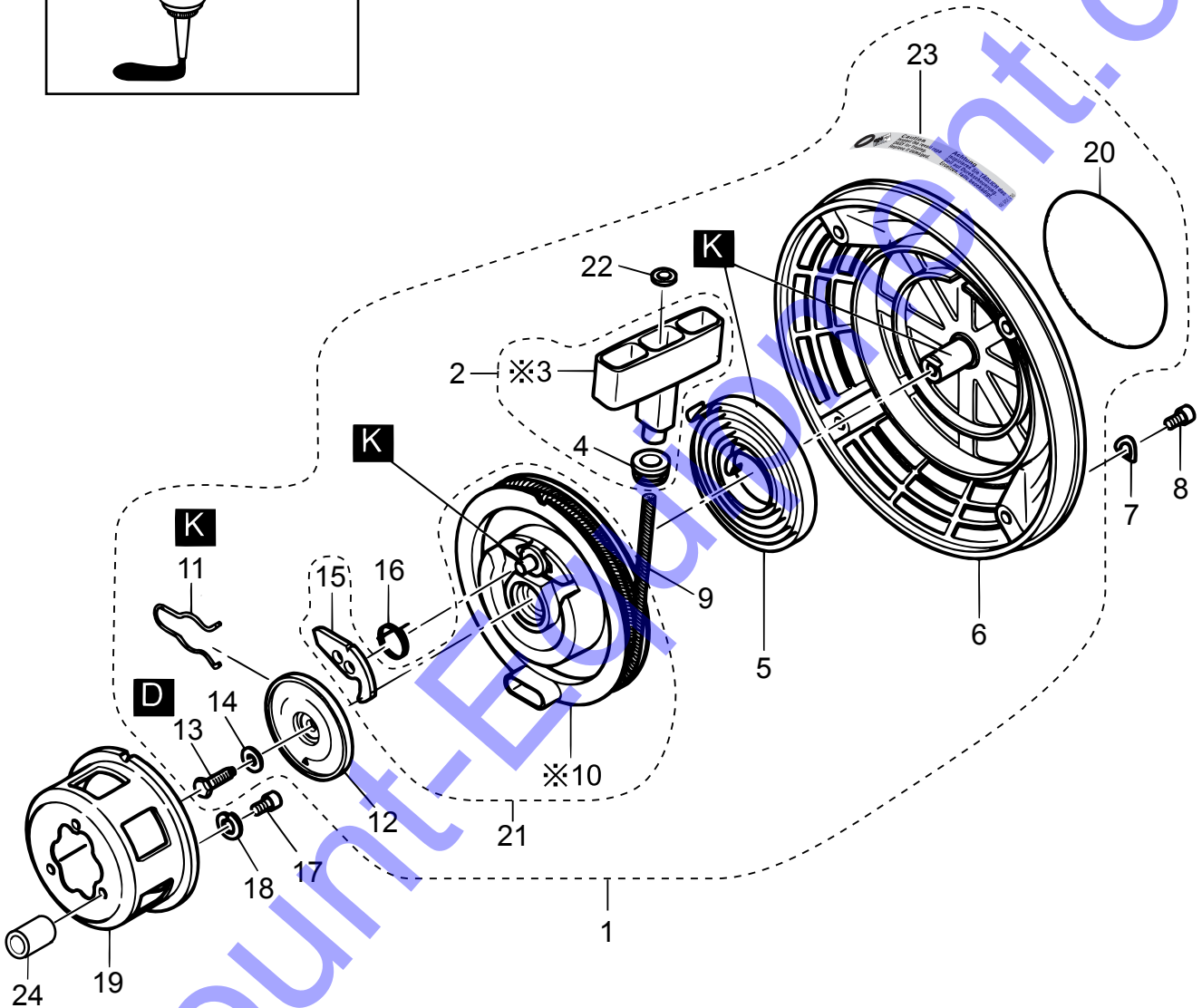
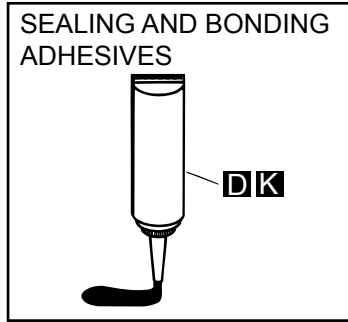

※ NOT SOLD SEPARATELY

## HATZ 1B50 ENGINE — RECOIL STARTER ASSY.

<u>NO.</u>	<u>PART NO.</u>	<u>PART NAME</u>	<u>QTY.</u>	<u>REMARKS</u>
D	50223300	LOCTITE 221	1	
K	50342601	HIGH TEMP. FETT 400G	1	
1	02319100	RECOIL-STARTER ASSY.....	1	INCLUDES ITEMS W/\$
2\$	01497800	STARTER KNOB ASSY. ....	1	INCLUDES ITEMS W/%
3\$%		KNOB, STARTER.....	1	NOT SOLD SEPARATELY
4\$%	03665200	RUBBER SLEEVE	1	
5\$	05045202	SPIRAL SPRING	1	
6\$	02308100	CASE RECOIL-STARTER	1	
7	50081200	WASHER, LOCK A6	4	
8	50062700	ALLEN SCREW M6X10	4	
9\$	01929000	ROPE, RECOIL	1	
10\$@		REEL.....	1	NOT SOLD SEPARATELY
11\$	05044901	BRAKE SPRING	1	
12\$	05045001	BRAKE DISC	1	
13\$	50146300	HEXAGON SCREW M6X18	1	
14\$	50390701	CON. WASHER, LOCK 6	1	
15 \$@	05044800	RATCHET, RECOIL STARTER	1	
16\$	05061300	RETURN SPRING	1	
17	50062700	ALLEN SCREW M6X10	3	
18	50170900	WASHER, LOCK 6	3	
19	04155000	STARTER PULLEY	1	
20\$	05109103	STICKER LABEL	1	
21\$	01548800	REEL WITH RATCHET, RECOIL .....	1	INCLUDES ITEMS W/@
22\$	50514600	WASHER 5.3	1	
23\$	05333801	STICKER	1	
24	05188600	SPACER BUSH 7X12X7	3	



# HATZ 1B50 ENGINE — AIR DUCTING A ASSY.

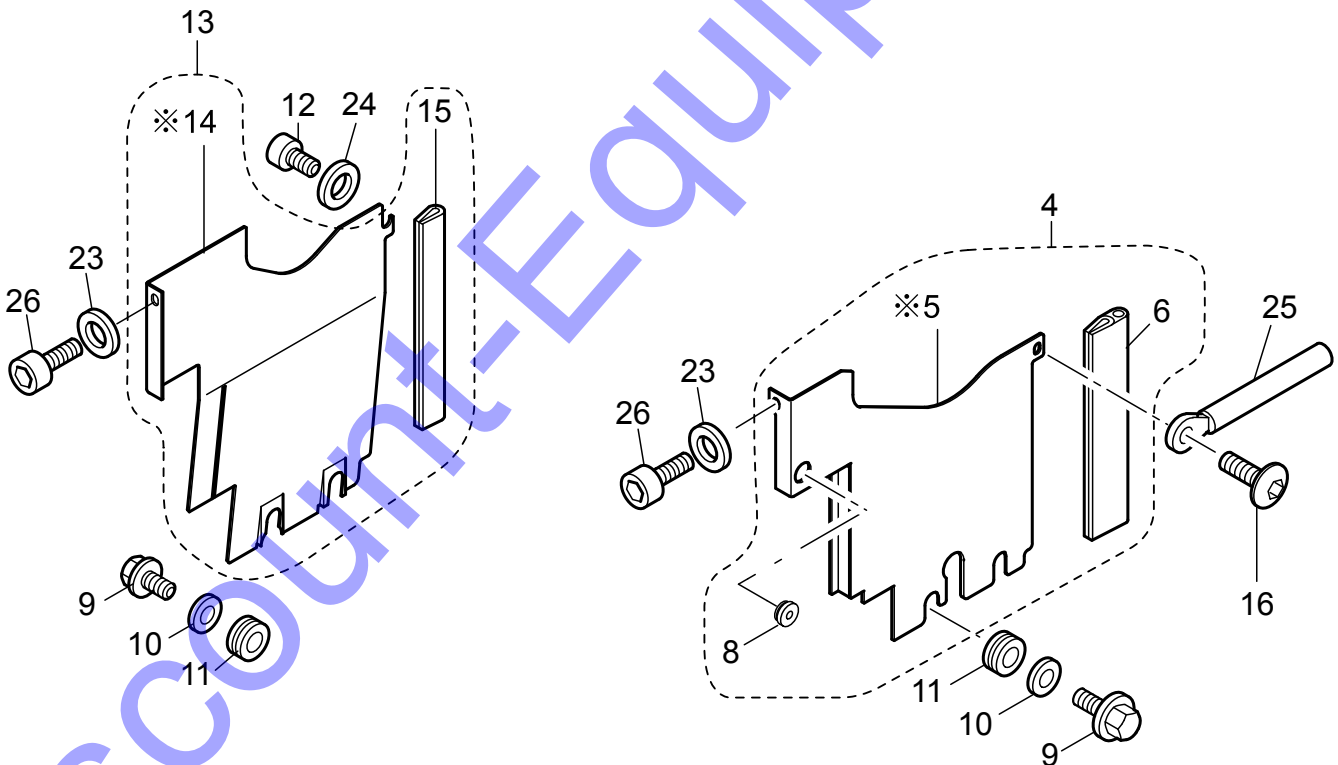
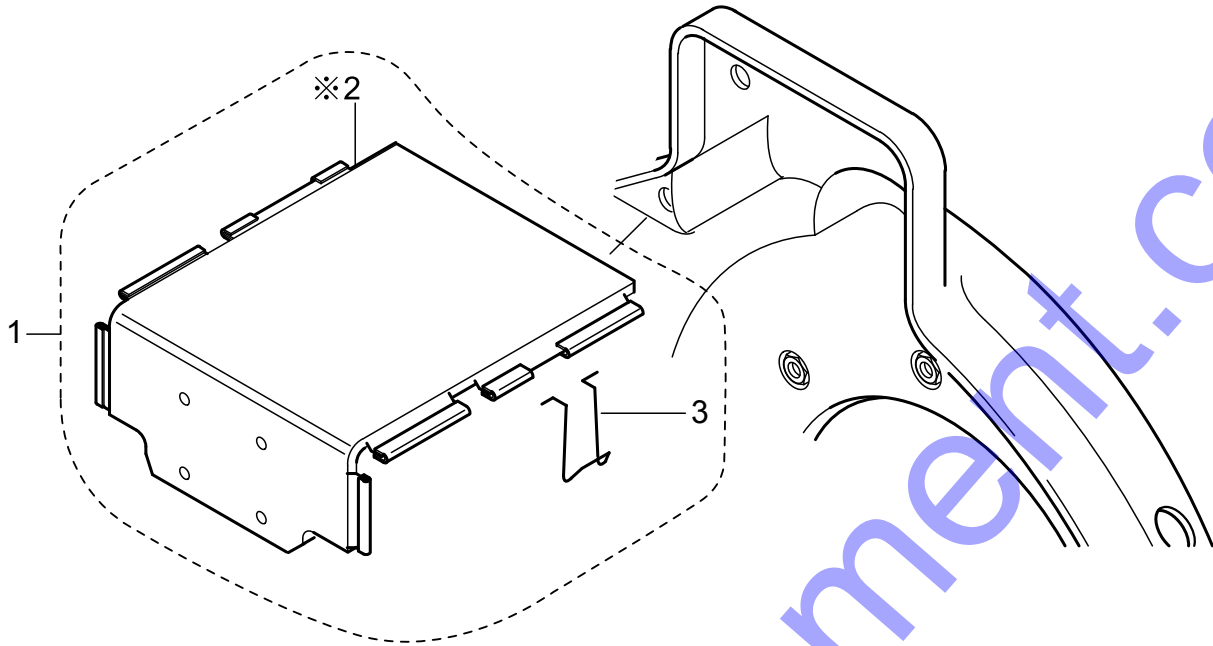

※ NOT SOLD SEPARATELY

## HATZ 1B50 ENGINE — AIR DUCTING A ASSY.

<u>NO.</u>	<u>PART NO.</u>	<u>PART NAME</u>	<u>QTY.</u>	<u>REMARKS</u>
1	01911801	HOOD ASSY. ....	1.....	INCLUDES ITEMS W/\$
2\$		HOOD .....	1.....	NOT SOLD SEPARATELY
3\$	05152100	SPRING CLIP	1	
4	01345410	COOLING AIR DUCTING .....	1.....	INCLUDES ITEMS W/%
5%		DUCT .....	1.....	NOT SOLD SEPARATELY
6%	04144210	SEALING STRIP 93MM	1	
8%	50334800	RUBBER SLEEVE	1	
9	50445401	FILLISTER HEAD SCREW M4X10	4	
10	50441600	WASHER 4.3	4	
11	50163801	RUBBER SLEEVE	4	
12	50528100	ALLEN SCREW M6X16	1	
13	01345310	COOLING AIR DUCTING 2 .....	1.....	INCLUDES ITEMS W/@
14@		DUCT 2.....	1.....	NOT SOLD SEPARATELY
15@	04144210	SEALING STRIP 93MM	1	
16	50495000	CHEESE-HEX HEAD SCREW M6X12	1	
22	03577200	SEALING STRIP	1	
23	50144500	WASHER, FLAT 6.4	2	
24	04060600	WASHER 6.4X16X1.5	1	
25	05001200	CLIP	1	
26	50474200	ALLEN SCREW M6X16	2	

# HATZ 1B50 ENGINE — AIR DUCTING B ASSY.

SEALING AND BONDING  
ADHESIVES

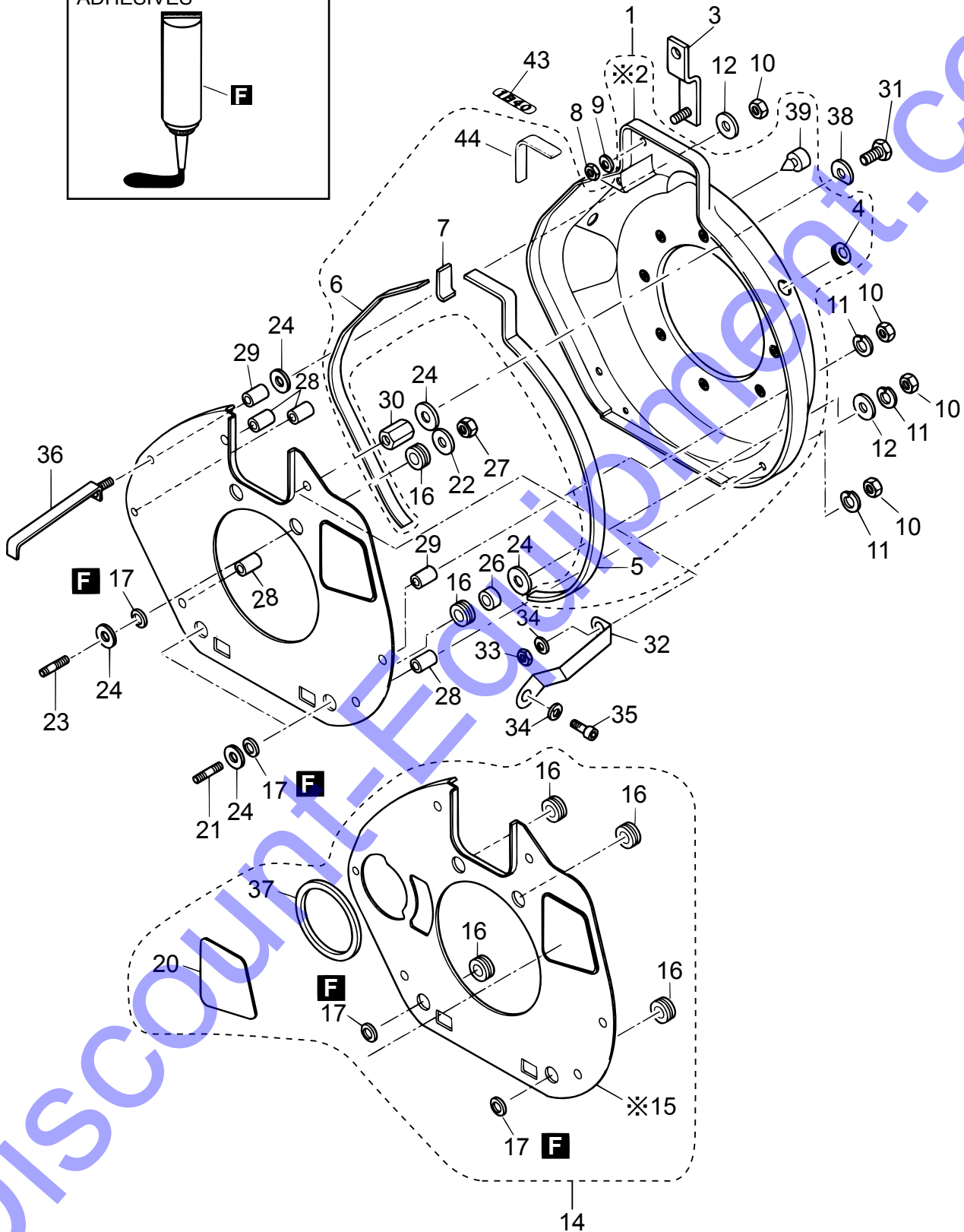
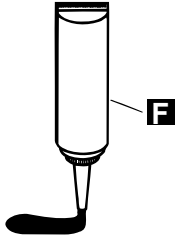

※ NOT SOLD SEPARATELY

## HATZ 1B50 ENGINE — AIR DUCTING B ASSY.

<u>NO.</u>	<u>PART NO.</u>	<u>PART NAME</u>	<u>QTY.</u>	<u>REMARKS</u>
F	50223800	TECHNICAL ADHESIVE 8058	1	
1	01831301	BLOWER DUCTING ASSY. ....	1	INCLUDES ITEMS W/\$
2\$		HOUSING, BLOWER DUCT.....	1	NOT SOLD SEPARATELY
3\$	01331300	SUPPORT	2	
4\$	50453300	RUBBER SLEEVE	1	
5\$	05401600	SEALING STRIP 715MM	1	
6\$	05401500	SEALING STRIP 555MM	1	
7\$	05401400	SEALING STRIP 57MM	1	
8	020106050	HEXAGON NUT M6 .....	2	REPLACES P/N 50144400
9	50170900	WASHER, LOCK 6	2	
10	020106050	HEXAGON NUT M6 .....	7	REPLACES P/N 50144400
11	50170900	WASHER, LOCK 6	8	
12	50120000	DISC A 6.4	3	
14	01347600	PROTECTION SHIELD.....	1	INCLUDES ITEMS W/%
15%		SHIELD, PROTECTION.....	1	NOT SOLD SEPARATELY
16%	01378300	SPACER BUSHING	4	
17%	03575500	RUBBER SEAL RING	4	
20%	04215200	CLOSING COVER	1	
21	50458100	STUD M6X45	2	
22	50114300	DISC 6.4	2	
23	50464401	STUD M6FOX35	2	
24	04042000	WASHER 6.5X22.5X1	7	
26	05188600	SPACER BUSH 7X12X7	2	
27	50328300	HEXAGON NUT VM6	2	
28	04139000	SPACER TUBE 6.5X12X18	4	
29	04098400	SPACER TUBE 7X12X16.3	2	
30	05184000	HEXAGON NUT M6X17	1	
31	50026400	HEXAGON SCREW M6X35	1	
32	01669400	SUPPORT	1	
33	020106050	HEXAGON NUT M6 .....	1	REPLACES P/N 50144400
34	50170900	WASHER, LOCK 6	2	
35	50170700	ALLEN SCREW M6X16	1	
36	01683300	SUPPORT	1	
37%	04099500	SEALING RING	1	
38	05140900	WASHER	1	
39\$	50392610	RUBBER BUSHING .....	1	SELECT 0-4
43	05314300	STICKER	1	
44\$	05401300	PROTECTION 58MM	1	

# HATZ 1B50 ENGINE — CRANKCASE BREATHING SYSTEM ASSY.

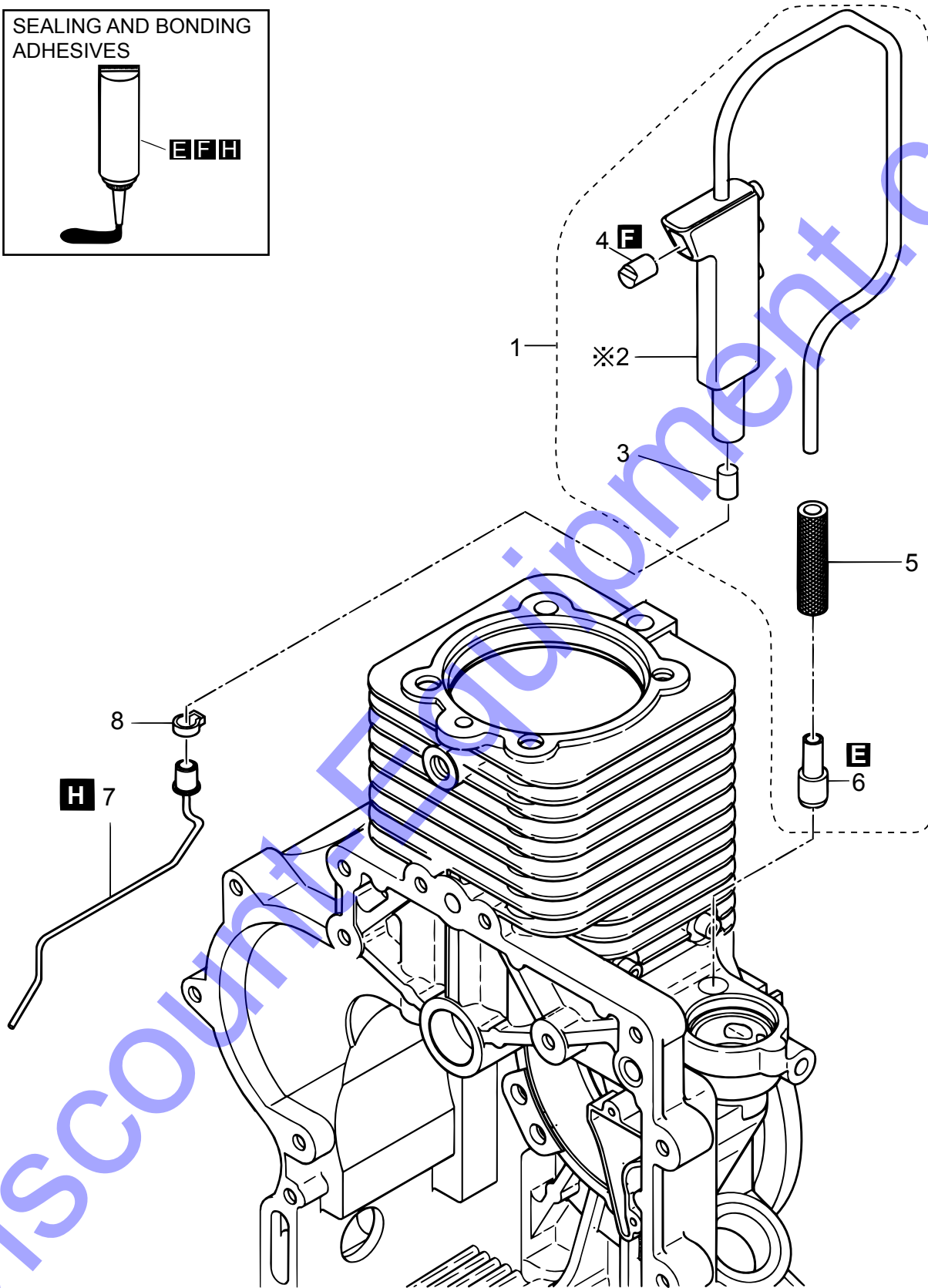
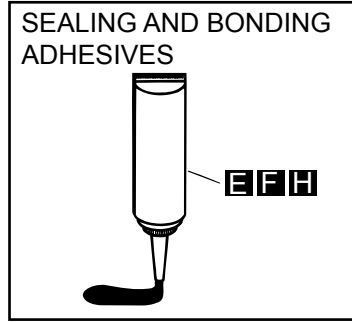

※ NOT SOLD SEPARATELY

## HATZ 1B50 ENGINE — CRANKCASE BREATHING SYSTEM ASSY.

<u>NO.</u>	<u>PART NO.</u>	<u>PART NAME</u>	<u>QTY.</u>	<u>REMARKS</u>
E	50223400	LOCTITE 648	1	
G	50256501	LOCTITE IS 407	1	
H	70018944	TEROSON TEROSTAT 63	1	
1	01885800	CRANKCASE BREATHER ASSY. ....	1	INCLUDES ITEMS W/%
2%		HOUSING, CRANKCASE BREATHER.....	1	NOT SOLD SEPARATELY
3%	05102900	FILTER BREATHING SYSTEM	1	
4%	05098100	PLUG	1	
5%	05197200	FUEL PIPE LW 7X35	1	
6%	05196000	NIPPLE	1	
7	01626900	SUCTION PIPE	1	
8	50456800	CLAMP	1	

# HATZ 1B50 ENGINE — FUEL ASSY.

SEALING AND  
BONDING  
ADHESIVES

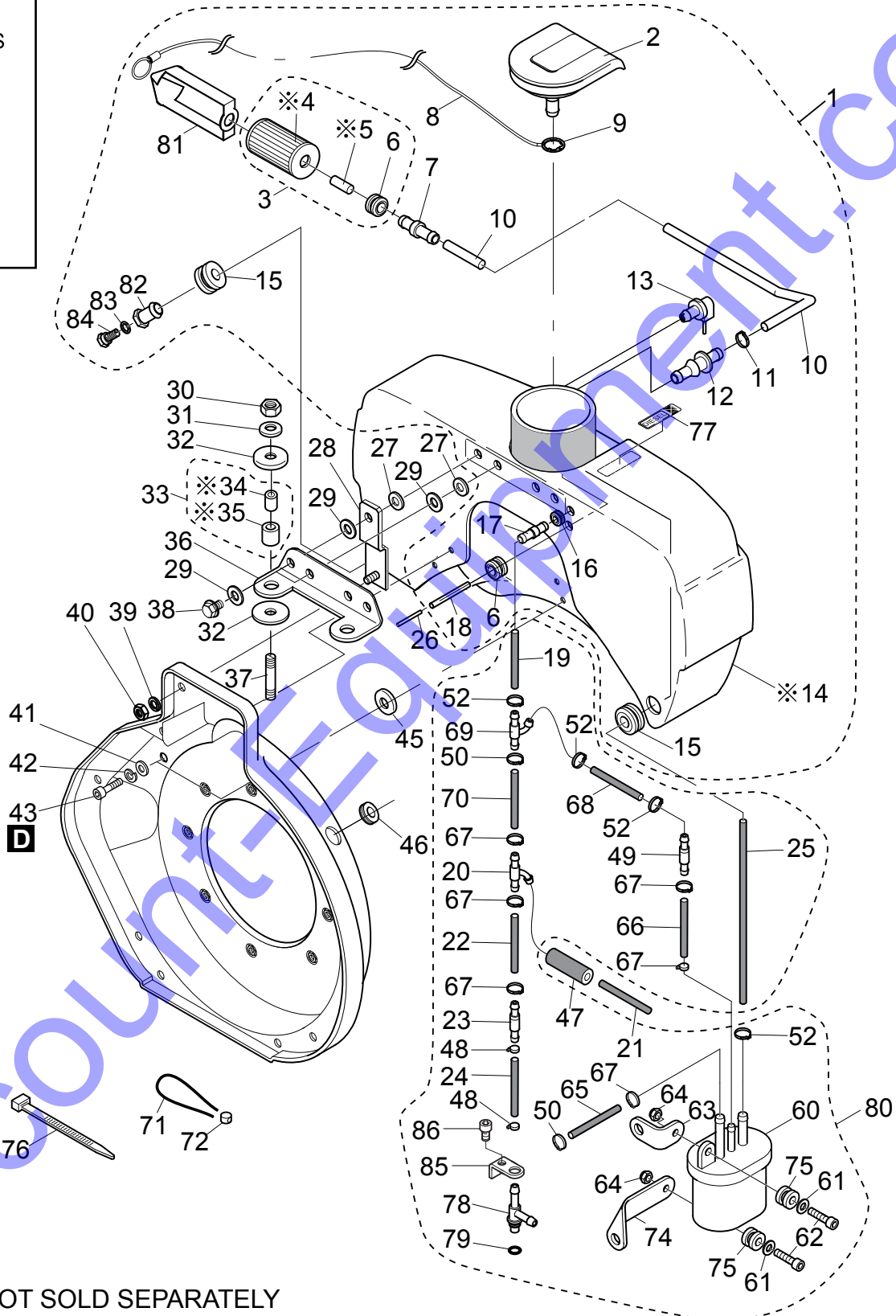

※ NOT SOLD SEPARATELY

## HATZ 1B50 ENGINE — FUEL ASSY.

<u>NO.</u>	<u>PART NO.</u>	<u>PART NAME</u>	<u>QTY.</u>	<u>REMARKS</u>
D	50223300	LOCTITE 221	1	
1	02221000	FUEL TANK ASSY., 5L .....	1	INCLUDES ITEMS W/\$
2\$	01535302	CAP, FUEL TANK	1	
3\$	01635210	FUEL FILTER ASSY.....	1	INCLUDES ITEMS W/%
4\$%		FUEL FILTER.....	1	NOT SOLD SEPARATELY
5\$%		BUSHING.....	1	NOT SOLD SEPARATELY
6\$%	50440901	RUBBER SLEEVE	2	
7\$	05189001	CONNECTING NIPPLE	1	
8\$	01628900	ROPE	1	
9\$	50500800	CIRCLIP 8	1	
10\$	05311100	FUEL HOSE 3.5X340	1	
11\$	50399801	CLAMP 11.3	1	
12\$	05084010	CONNECTING NIPPLE	1	
13\$	01534900	FUEL VENTING VALVE	1	
15\$	50440800	RUBBER SLEEVE	2	
16\$	05130400	RUBBER SLEEVE	1	
17\$	05184400	CONNECTING NIPPLE	1	
18\$	05189700	BREATHER HOSE	1	
19#	05289300	FUEL HOSE 5.0X50	1	
20#	05175602	HOSE NIPPLE T	1	
21	04282000	HOSE 2.5X245	1	
22#	03664210	HOSE 5X130	1	
23#	01534601	FUEL VENTING VALVE	1	
24#	05366400	FUEL PIPE 6X40	1	
25#	05347600	FUEL HOSE 3.5X215	1	
26	05141800	TUBE 2X0.3X25	1	
27	50120000	DISC A 6.4	4	
28	01331300	SUPPORT	2	
29	05110010	DISC 7.1X17.9X2	10	
30	020108060	HEXAGON NUT M8 .....	2	REPLACES P/N 40028400
31	50148100	WASHER, FLAT 8.4	2	
32	05109810	DISC 8.20X22X2	4	
33	01655800	INSULATING TUBE ASSY.....	2	INCLUDES ITEMS W/@
34@		TUBE .....	1	NOT SOLD SEPARATELY
35@		INSULATION.....	1	NOT SOLD SEPARATELY
36	05170110	SUPPORT	1	
37	50231900	STUD M8X25	2	
38	01557000	HEXAGON SCREW M6X16	4	
39	50170900	WASHER, LOCK 6	2	
40	50144000	HEXAGON SCREW M8X40	2	
41	50120000	DISC A 6.4	4	
42	50170900	WASHER, LOCK 6	4	
43	50149100	ALLEN SCREW M6X12	4	



# HATZ 1B50 ENGINE — FUEL ASSY. (CONTINUED)

SEALING AND  
BONDING  
ADHESIVES

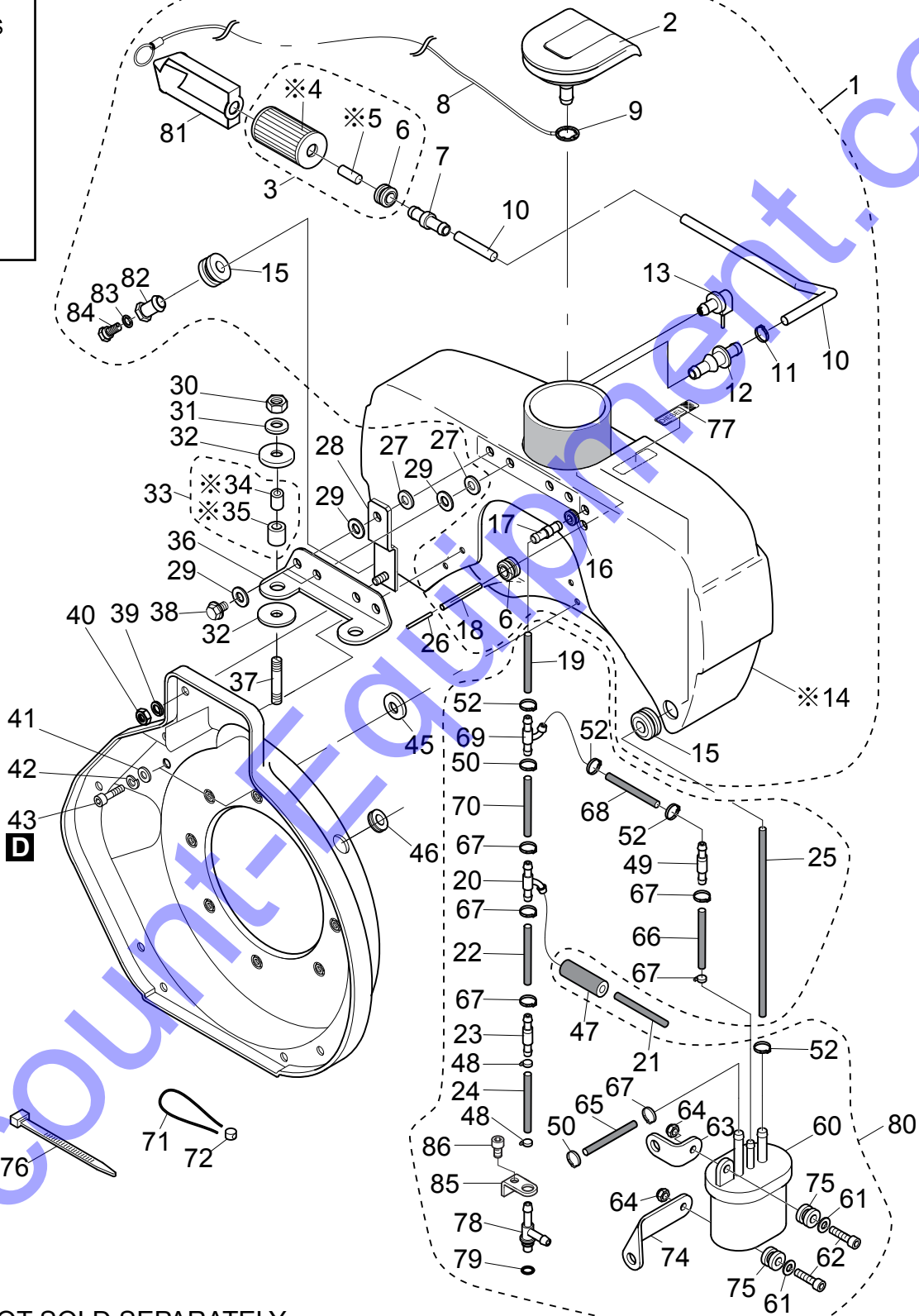

※ NOT SOLD SEPARATELY

## HATZ 1B50 ENGINE — FUEL ASSY. (CONTINUED)

<u>NO.</u>	<u>PART NO.</u>	<u>PART NAME</u>	<u>QTY.</u>	<u>REMARKS</u>
45	04042000	WASHER 6.5X22.5X1	2	
46	50453300	RUBBER SLEEVE	1	
47	05213010	INSULATING HOSE 25MM	1	
48#	50570900	CLAMP 12.8	2	
49#	00805502	VENT VALVE	1	
50#	50590000	CLAMP 12.0	1	
52#	50399801	CLAMP 11.3	4	
60#	01919702	FUEL FILTER, EXTERNAL MTG.	1	
61#	50441600	WASHER 4.3	2	
62#	50446900	ALLEN SCREW M4X16	2	
63#	05279500	SUPPORT	1	
64#	50501600	HEXAGON NUT M4	2	
65#	03663610	FUEL HOSE 5X330	1	
66#	03663610	FUEL HOSE 5X330	1	
67#	50570900	CLAMP 12.8	5	
68#	05289300	FUEL HOSE 5.0X50	1	
69#	05122701	HOSE NIPPLE T	1	
70#	03663710	FUEL HOSE 5.0X50	1	
71#	40021500	SEAL WIRE 0.5-0.3	1	
72#	40021400	LEAD SEAL 8MM	1	
74#	05285400	SUPPORT	1	
75#	50556600	RUBBER SLEEVE	2	
76	50358400	STRAP	2	
77\$	05235602	STICKER DIESEL	1	
78#	01756800	NIPPLE	1	
79#	50154300	O-RING 7.5X10.5X1.5	1	
80	02299400	FUEL PIPE ASSY. (INCLUDES FILTER)	1	INCLUDES ITEMS W/#
81\$	05253400	SUPPORT FUEL FILTER	1	
82\$	05188200	CONNECTING NIPPLE	1	
83\$	50313100	JOINT A6X10	1	
84\$	03613600	VENT SCREW M6	1	
85#	05390700	SUPPORT	1	
86#	50547000	ALLEN SCREW M5X25	1	

# HATZ 1B50 ENGINE — AIR FILTER ASSY.

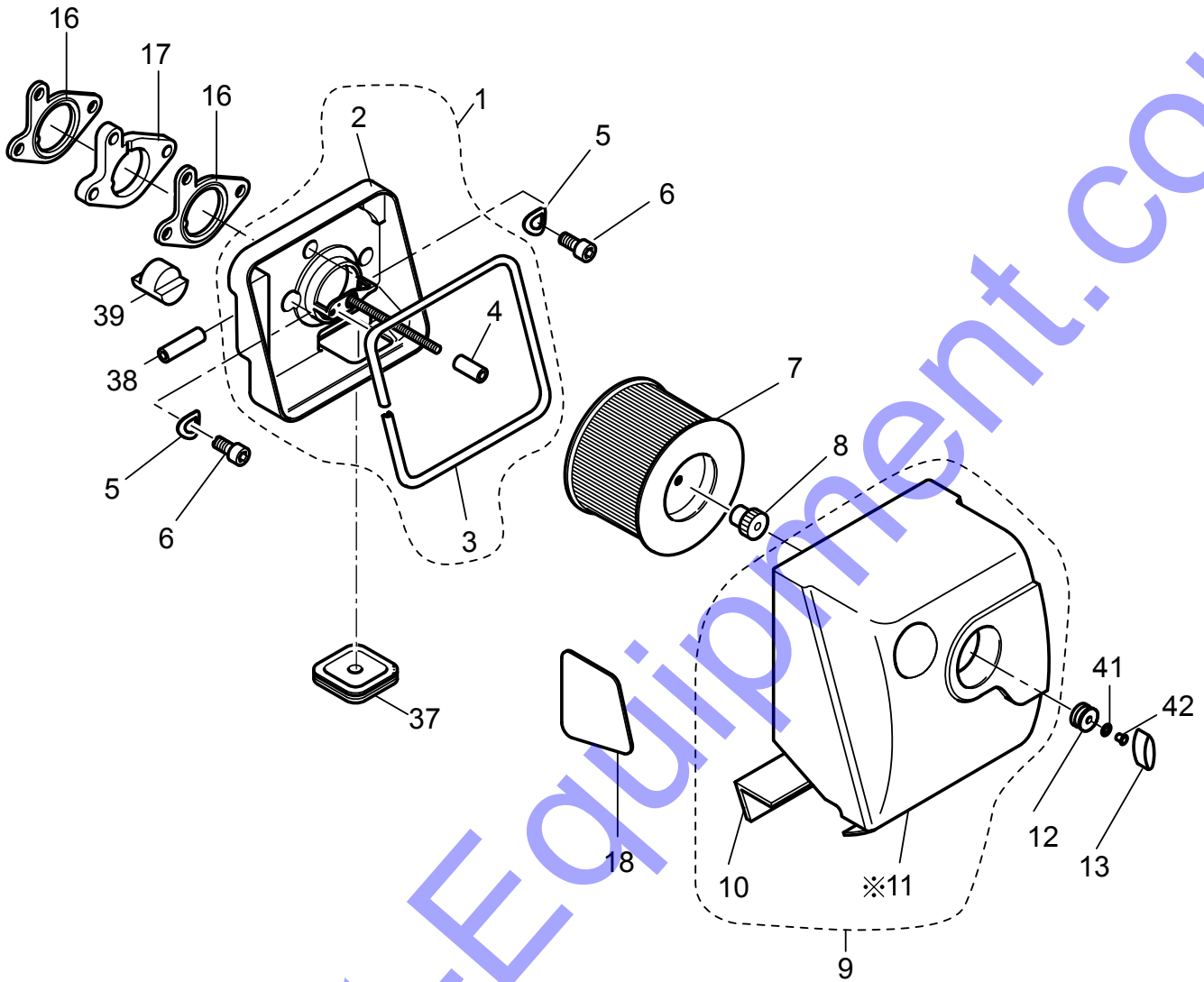

## HATZ 1B50 ENGINE — AIR FILTER ASSY.

<u>NO.</u>	<u>PART NO.</u>	<u>PART NAME</u>	<u>QTY.</u>	<u>REMARKS</u>
1	01637410	AIR FILTER HOUSING ASSY. ....	1	INCLUDES ITEMS W/\$
2\$		HOUSING, AIR FILTER .....	1	NOT SOLD SEPARATELY
3\$	05167700	SEALING STRIP 665MM	1	
4\$	05166200	RUBBER SHELL 32MM	1	
5	50095100	WASHER, LOCK A8	3	
6	50171500	ALLEN SCREW M8X25	3	
7\$	50484100	AIR FILTER ELEMENT	1	
8	50454300	KNURLED NUT M6	1	
9	01822001	COVER, AIR FILTER ASSY. ....	1	INCLUDES ITEMS W/%
10%	05158000	SEALING STRIP	1	
11%		COVER, AIR FILTER .....	1	NOT SOLD SEPARATELY
12	50435800	RUBBER SLEEVE	1	
13	50452200	WING NUT M6	1	
16	05149900	GASKET AIR FILTER	2	
17	05149801	INSULATING FLANGE	1	
18	04215200	CLOSING COVER	1	
37	04215300	CLOSING COVER	1	
38	05309300	BREATHER TUBE	1	
39	05098100	PLUG	1	
41	50591500	SHIM 9X15X1.0	1	
42	50591600	TUBE RIVET A8X0.5X12	1	

# HATZ 1B50 ENGINE — EXHAUST SILENCER ASSY.

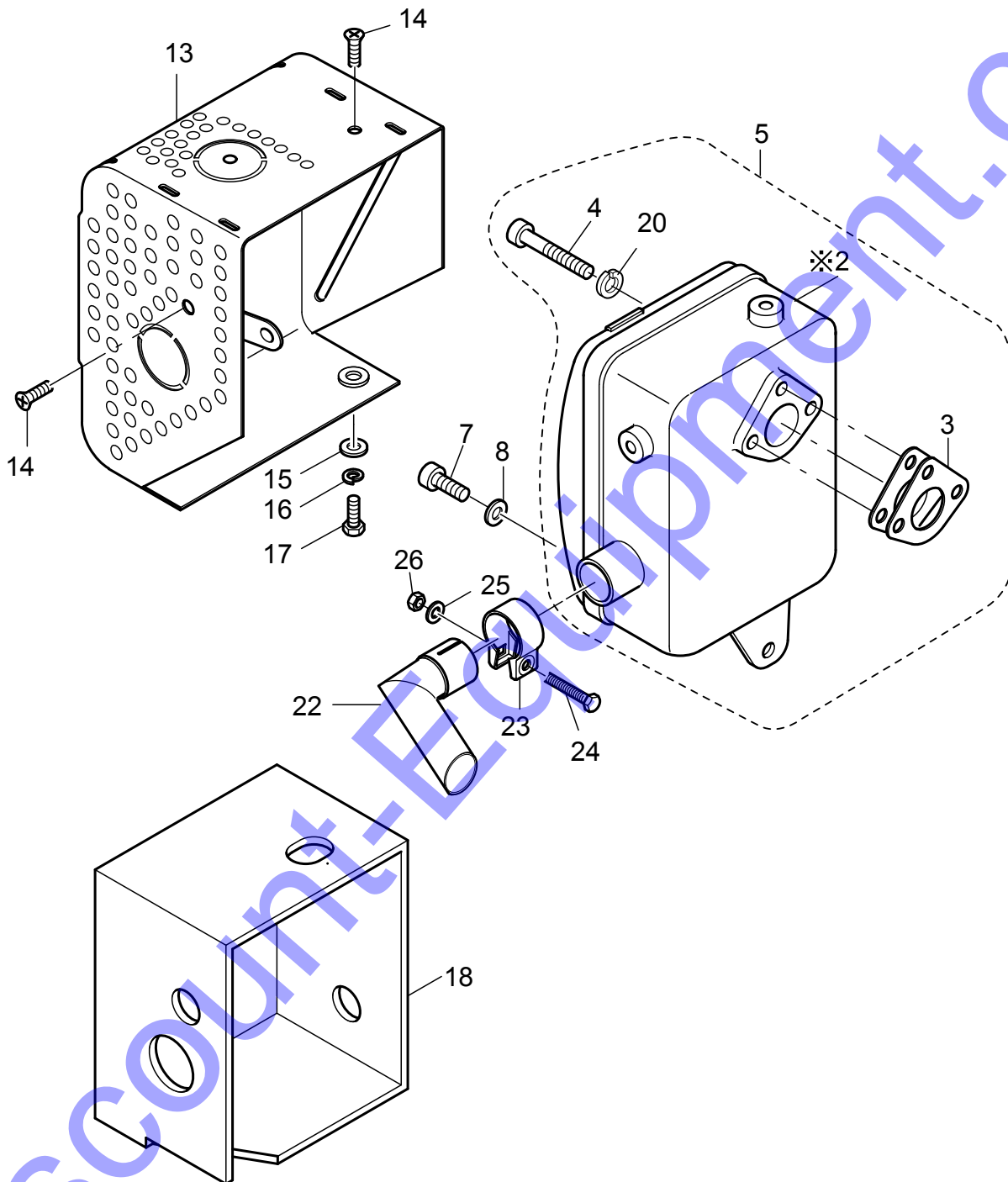

※ NOT SOLD SEPARATELY

## HATZ 1B50 ENGINE — EXHAUST SILENCER ASSY.

<u>NO.</u>	<u>PART NO.</u>	<u>PART NAME</u>	<u>QTY.</u>	<u>REMARKS</u>
2\$	01872502	EXHAUST SILENCER	1	
3\$	01732701	GASKET MUFFLER	1	
4\$	50403900	ALLEN SCREW M8X25	3	
5	01701601	EXHAUST SILENCER ASSY. ....	1	INCLUDES ITEMS W/\$
7	50474200	ALLEN SCREW M6X16	1	
8	50114300	DISC 6.4	1	
13	01629001	PROTECTION GUARD EXHAUST	1	
14	50422501	COUNTERSUNK SCREW M6X12	2	
15	50114300	DISC 6.4	1	
16	50170900	WASHER, LOCK 6	1	
17	50177100	HEXAGON SCREW M6X16	1	
18	01883502	INSULATION, EXHAUST SILENCER	1	
20\$	50208500	WASHER, LOCK 8	3	
22	468352160	EXHAUST PIPE	1	
23	03740900	PIPE CLIP	1	
24	50380000	HEXAGON SCREW M8X50	1	
25	50148100	WASHER, FLAT 8.4	1	
26	020108060	HEXAGON NUT M8 .....	1	REPLACES P/N 40028400

# HATZ 1B50 ENGINE — STARTER, ALTERNATOR ASSY.

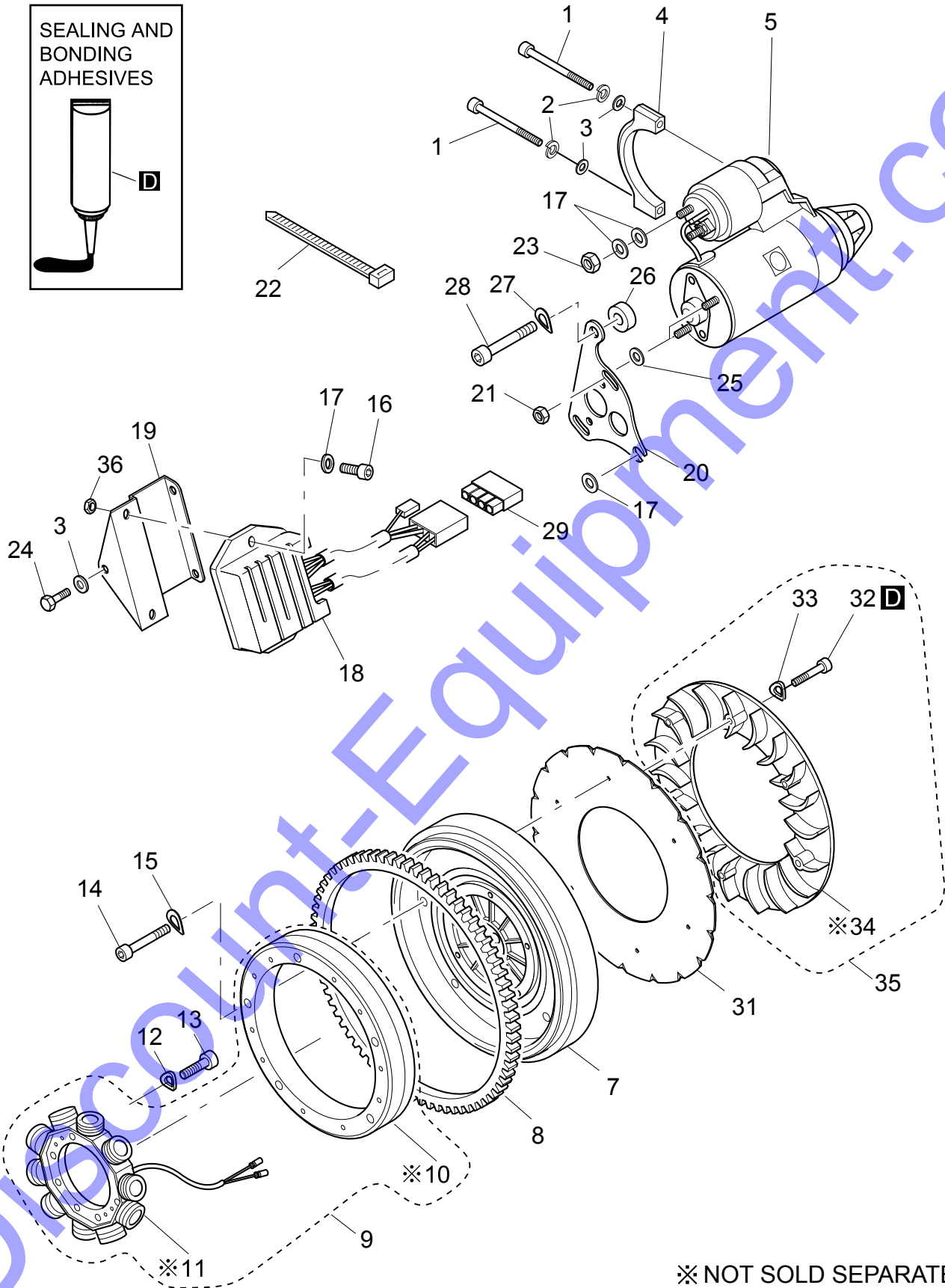
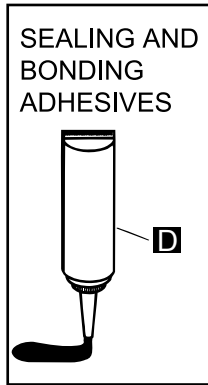

※ NOT SOLD SEPARATELY

## HATZ 1B50 ENGINE — STARTER, ALTERNATOR ASSY.

NO.	PART NO.	PART NAME	QTY.	REMARKS
	50223300	LOCTITE 221	1	
1	50402300	ALLEN SCREW M6X70	2	
2	50170900	WASHER, LOCK 6	4	
3	50144500	WASHER, FLAT 6.4	3	
4	04099100	RETAINING BRACKET	1	
5	50483500	ELECTRIC STARTER 12V 1.0 KW	1	
7	04234700	FLYWHEEL	1	
8	04151100	GEAR RING	1	
9	01926100	ALTERNATOR 12V 200W .....	1	INCLUDES ITEMS W/\$
10\$		INDUCTOR RING, ALTERNATOR.....	1	NOT SOLD SEPARATELY
11\$		STATER.....	1	NOT SOLD SEPARATELY
12	50081900	WASHER, LOCK A5	4	
13	50547000	ALLEN SCREW M5X25	4	
14	50236600	ALLEN SCREW M6X25	5	
15	50081200	WASHER, LOCK A6	5	
16	50183000	ALLEN SCREW M8X35	2	
17	50148100	WASHER, FLAT 8.4	6	
18	02270800	TENSION REGULATOR 12V	1	
19	01663000	SUPPORT	1	
20	05182912	SUPPORT	1	
21	50602400	HEXAGON NUT M6	2	
22	50439500	STRAP 2.6X200	3	
23	50344700	HEXAGON NUT M8	1	
24	50025400	HEXAGON SCREW M6X10	1	
25	50120000	DISC A 6.4	2	
26	03714100	SPACER BUSHING	1	
27	50095100	WASHER, LOCK A8	1	
28	50392900	ALLEN SCREW M8X50	1	
29	50402100	PLUG SLEEVE HOUSING	1	
31	01390800	PLATE	1	
32%	50327300	ALLEN SCREW M4X20	6	
33%	50003400	WASHER, LOCK A4	6	
34%		BLOWER RING .....	1	NOT SOLD SEPARATELY
35	01934300	BLOWER RING W/ WASHER AND SCREW.....	1	INCLUDES ITEMS W/%
36	50514100	HEXAGON NUT M8	2	



# HATZ 1B50 ENGINE — ELECTRIC EQUIPMENT, WIRINGS ASSY.

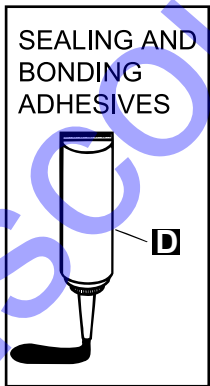
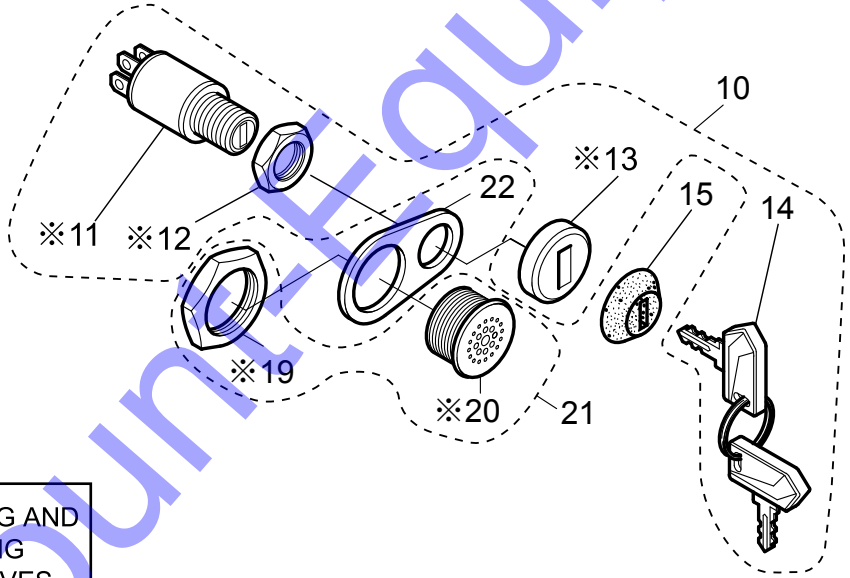
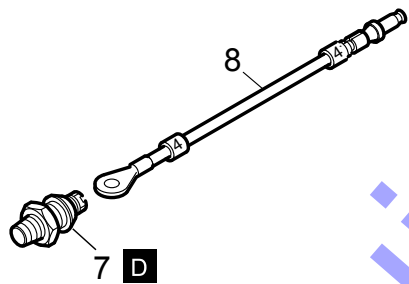
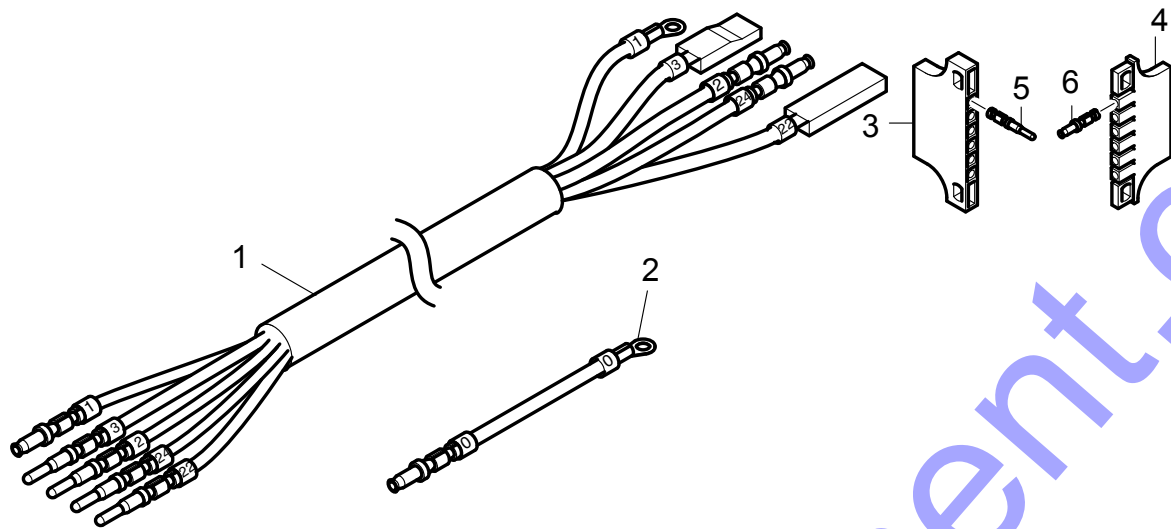

※ NOT SOLD SEPARATELY

## HATZ 1B50 ENGINE — ELECTRIC EQUIPMENT, WIRINGS ASSY.

<u>NO.</u>	<u>PART NO.</u>	<u>PART NAME</u>	<u>QTY.</u>	<u>REMARKS</u>
1	01667001	WIRING HARNESS	1	
2	01548300	ELECTRIC WIRE 220MM	1	
3	50373600	PIN TERMINAL HOUSING 6-WAY	1	
4	50373700	PLUG SLEEVE HOUSING	1	
5	50374100	PIN, TERMINAL 0.5-1	5	
6	50373900	SLEEVE 1.5-2.5	6	
7	50469101	OIL PRESSURE SWITCH	1	
8	01548000	ELECTRIC WIRE	1	
10	50384401	SWITCH, KEY ASSY. ....	1	INCLUDES ITEMS W/\$
11\$		SWITCH, IGNITION.....	1	NOT SOLD SEPARATELY
12\$		NUT, RETAINING.....	1	NOT SOLD SEPARATELY
13\$		COVER, SWITCH.....	1	NOT SOLD SEPARATELY
14\$	50404900	IGNITION SWITCH KEY	2	
15	05126402	PROTECTION CAP	1	
19%		NUT, RETAINER.....	1	NOT SOLD SEPARATELY
20%		BUZZER.....	1	NOT SOLD SEPARATELY
21	50465100	BUZZER 12/24V W/ NUT.....	1	INCLUDES ITEMS W/%
22	05131801	FASTENING PLATE	1	

# HATZ 1B50 ENGINE — SPEED CONTROL BOWDENCABLE ASSY.

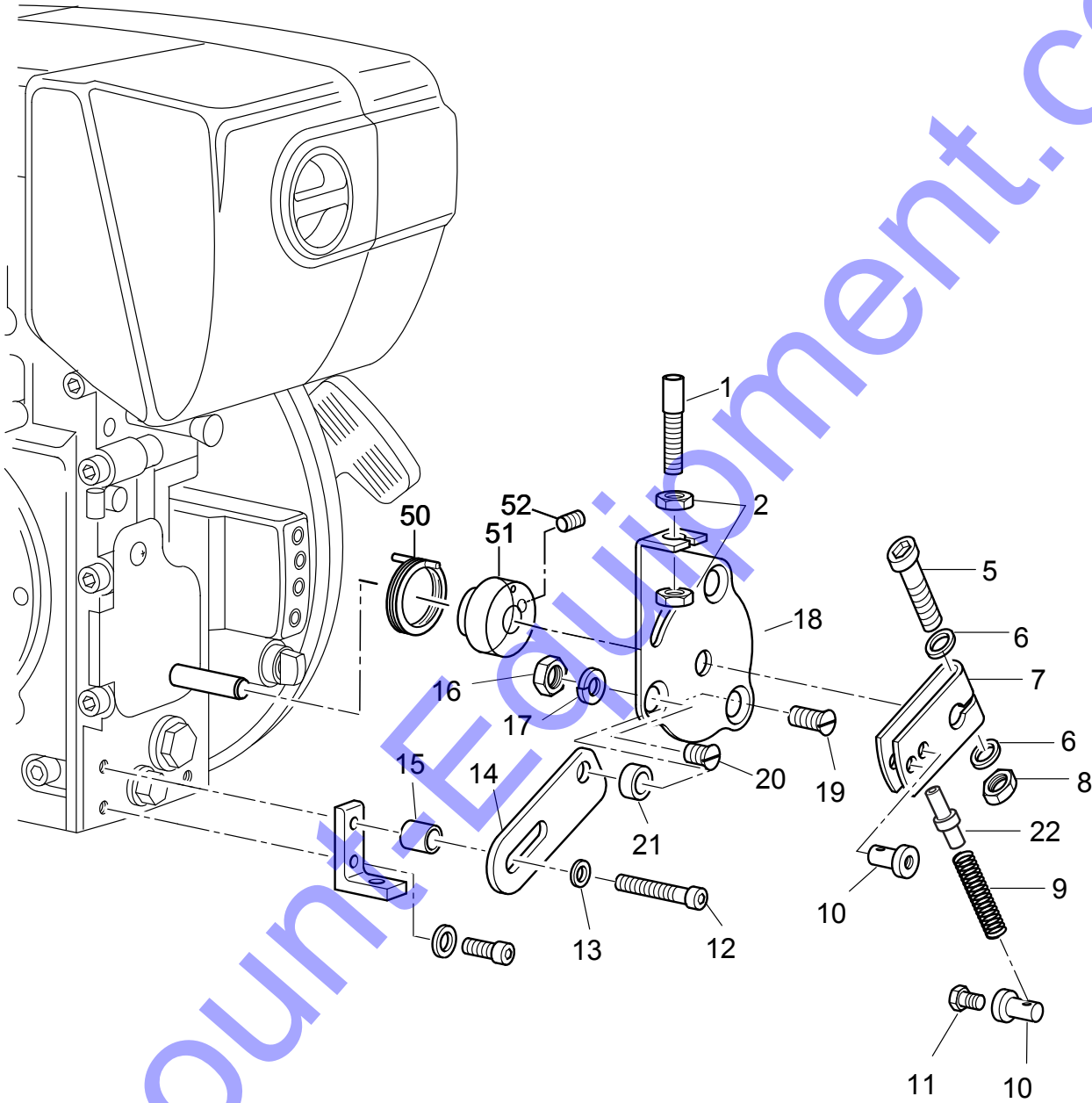

## HATZ 1B50 ENGINE — SPEED CONTROL BOWDENCABLE ASSY.

<u>NO.</u>	<u>PART NO.</u>	<u>PART NAME</u>	<u>QTY.</u>	<u>REMARKS</u>
1	05141200	ADJUSTING SCREW	1	
2	020406040	NUT M6, H=4.2	2	
5	50511900	ALLEN SCREW M5X30	1	
6	50216300	WASHER 5.3	2	
7	05117700	LEVER	1	
8	50094300	HEXAGON NUT M5	1	
9	50483200	PRESSURE SPRING	1	
10	50483100	CABLE CLAMPING 2.2MM	2	
11	50025000	HEXAGON SCREW M4X10	1	
12	50342400	ALLEN SCREW M8X50	1	
13	50148100	WASHER, FLAT 8.4	1	
14	05189600	PLATE, SPEED CONTROL	1	
15	03599600	SPACER BUSHING	1	
16	50328300	HEXAGON NUT VM6	1	
17	50208500	WASHER, LOCK 8	1	
18	05117610	CONSOLE	1	
19	50423900	COUNTERSUNK SCREW M6X20	1	
20	50380800	COUNTERSUNK SCREW M6X10	1	
21	03292900	SPACER TUBE	1	
22	05165000	GUIDE BUSHING	1	
50	05154010	SPRING	1	
51	05179000	BUSHING	1	
52	50400600	GRUB SCREW M5X10	1	

# HATZ 1B50 ENGINE — SPEC. EQUIPMENT EPA ASSY.

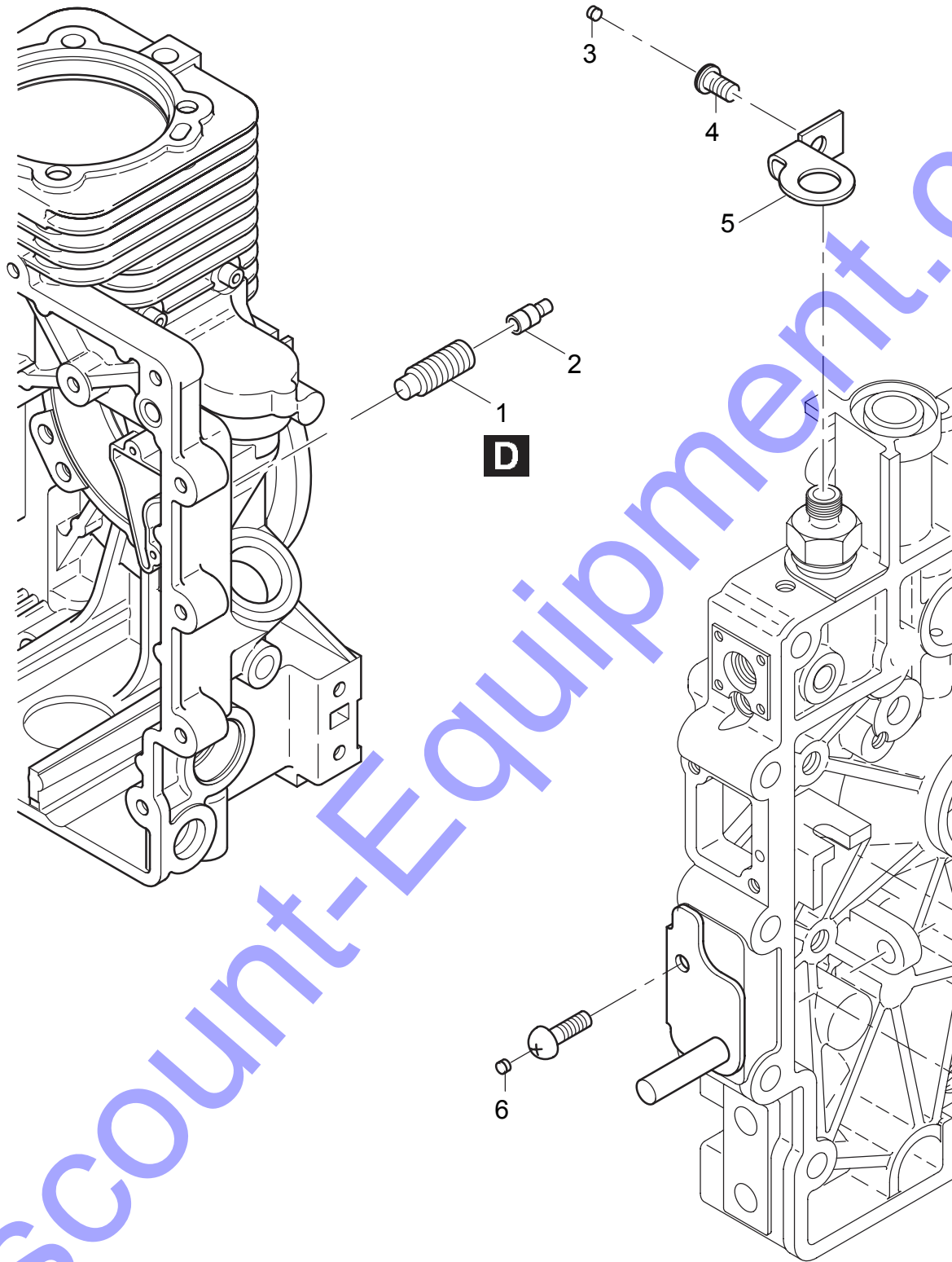

## HATZ 1B50 ENGINE — SPEC. EQUIPMENT EPA ASSY.

<u>NO.</u>	<u>PART NO.</u>	<u>PART NAME</u>	<u>QTY.</u>	<u>REMARKS</u>
D	50223300	LOCTITE 221	1	
1	04198800	GRUB SCREW CARB	1	
2	04150500	CLOSING PLUG 6 CARB	1	
3	04170600	PLUG 4.15	1	
4	50495000	CHEESE-HEX SCREW M6X12	1	
5	04185301	GUARD	1	
6	05201500	CLOSING PLUG	1	

# **Discount Equipment**

Discount-Equipment.com is your online resource for commercial and industrial quality parts and equipment sales.

## **Locations:**

Florida (West Palm Beach): [561-964-4949](tel:561-964-4949)

Outside Florida TOLL FREE: [877-690-3101](tel:877-690-3101)

**Need parts?** Check out our website at [www.discount-equipment.com](http://www.discount-equipment.com)

## **Can't find what you need?**

Click on this link: <http://www.discount-equipment.com/category/5443-parts/> and fill out the request form.

Please have the machine model and serial number available in order to help us get you the correct parts. One of our experienced staff members will get back to you with a quote for the right part that your machine needs.

We sell worldwide for the brands: Genie, Terex, JLG, MultiQuip, Mayco, Toro/Stone, Diamond Products, Magnum, Airman, Mustang, Power Blanket, Nifty Lift, Atlas Copco, Chicago Pneumatic, Allmand Brothers, Essick, Miller Spreader, Skyjack, Lull, Skytrak, Tsurumi, Husquyarna/Target, Whiteman-Concrete/Mortar, Stow-Concrete/Mortar, Baldor, Wacker, Sakai, Snorkel, Upright, Mi-T-M, Sullair, Neal, Basic, Dynapac, MBW, Weber, Bartell, Bennar Newman, Haulotte, Ditch Runner, Blaw-Knox, Himoina, Best, Buddy, Crown, Edco, Wyco, Bomag, Laymor, Terremite, Barreto, EZ Trench, Takeuchi, Basic, Bil-Jax, Curtis, Gehl, Heli, Honda, ICS/PowerGrit, Puckett, Waldon, ASV, IHI, Partner, Imer, Clipper, MMD, Koshin, Rice, Gorman Rupp, CH&E, Cat Pumps, Comet, General Pump, Giant, AMida, Coleman, NAC, Gradall, Square Shooter, Kent, Stanley, Tamco, Toku, Hatz, Kohler, Robin, Wisconsin, Northrock, Oztec, Toker TK, Rol-Air, Small Line, Wanco, Yanmar