

OPERATION AND PARTS MANUAL

STOW

Floor Covering Scraper Model SFCS-16

Revision #0 (07/22/03)

STOW
A DIVISION OF MULTQUIP INC.

STOW CONSTRUCTION EQUIPMENT
A DIVISION OF MULTQUIP INC.
POST OFFICE BOX 6254
CARSON, CA 90749
310-537-3700 • 888-252-STOW [888-252-7869]
FAX: 310-537-1986 • FAX: 800-556-1986
E-MAIL: stow@multiquip.com • WWW:
stowmfa.com

PARTS DEPARTMENT:
800-427-1244
FAX: 800-672-7877
**SERVICE
DEPARTMENT/TECHNICAL
ASSISTANCE:**
800-478-1244
FAX: 310-631-5032



WARNING



CALIFORNIA — Proposition 65 Warning

Engine exhaust and some of its constituents, and some dust created by power sanding, sawing, grinding, drilling and other construction activities contains chemicals known to the State of California to cause cancer, birth defects and other reproductive harm. Some examples of these chemicals are:

- Lead from lead-based paints.
- Crystalline silica from bricks.
- Cement and other masonry products.
- Arsenic and chromium from chemically treated lumber.

Your risk from these exposures varies, depending on how often you do this type of work. To reduce your exposure to these chemicals: **ALWAYS** work in a well ventilated area, and work with approved safety equipment, such as dust masks that are specially designed to filter out microscopic particles.

STOW SFCS-16 Floor Covering Scraper

Table Of Contents.....	3
Parts Ordering Procedures.....	4
Notice to Operators.....	5-6
Operator Instructional Data Sheet.....	7
Safety Precautions.....	8
Preparation.....	X
Operation.....	X
Maintenance, Repair and Storage.....	X
Assembly.....	X
Removing the Floor Covering Scrapper from the pallet.....	X
Installation of the Adjustable Section of the Operator Handle.....	X
Before Starting the Motor.....	X
Theory of Operation.....	X
Blade Configurations, Accessory Attacments and Applications.....	X
Installing a Blade or Ceramic Tile Ripper Attachment from the Floor Covering Scrapper.....	X
Removing a Blade or Ceramic Tile Ripper Attachment from the Floor Covering Scrapper.....	X
Operation.....	X
Operational Disclaimer.....	X
California Proposition 65 Disclaimer.....	X
Transporting the Floor Covering Scraper.....	X
Adjusting the Operator Handle Height.....	X
Starting the Floor Covering Scraper.....	X
Operating the Floor Covering Scraper On the Jobsite.....	X
Stopping the Floor Covering Scraper On the Jobsite.....	X
Operational Parameters and Techniques for the Floor Covering Scraper.....	X
Service.....	X
Preventative Maintenance Check List.....	X
Lubrication Requirements.....	X
Electric Motor Service.....	X
Troubleshooting.....	X
Electric Motor.....	X
Operational Problems.....	X
Storage.....	X
Specifications.....	X
Component Parts Drawings	
Frame Assembly.....	XX-XX
Handle Assembly.....	XX-XX
Adjustable Axle Assembly.....	XX-XX
Decals.....	XX-XX
Replacement Cutting Blades.....	XX-XX

PARTS ORDERING PROCEDURES

When ordering parts,
please supply the following information:

- Dealer account number
- Dealer name and address
- Shipping address (if different than billing address)
- Return fax number
- Application Model number
- Quantity, part number and description of each
- Specify preferred method of shipment:
 - ✓ FedEx or UPS Ground
 - ✓ FedEx or UPS Second Day or Third Day
 - ✓ FedEx or UPS Next Day
 - ✓ Federal Express Priority One
 - ✓ DHL
 - ✓ Truck

Note: Unless otherwise indicated by customer, all orders are treated as "Standard Orders", and will ship within 24 hours. We will make every effort to ship "Air Shipments" the same day that the order is received, if prior to 2PM west coast time. "Stock Orders" must be so noted on fax or web forms.



Here's how to get help...

Please have the model and serial number on hand when calling.

Parts Department

800-427-1244 Fax: 800-672-7877
310-537-3700 Fax: 310-637-3284

Service Department

800-478-1244 Fax: 310-537-4259
310-537-3700

Warranty Department

800-421-1244, Ext. 279 Fax: 310-537-1173
310-537-3700, Ext. 279

Sales Department

310-661-4242 Fax: 310-604-9237
877-289-7869 (877-BUY STOW)

Place Your Parts Order Via Web or Fax For Even More Savings!

Extra Discounts!

All parts orders which include complete part numbers and are received by our automated web parts order system, or by fax qualify for the following extra discounts:

Ordered via	Standard orders	Stock orders (\$750 list and above)
Fax	3%	10%
Web	5%	10%

Special freight allowances when you order 10 or more line items via Web or Fax! **

FedEx Ground Service **at no charge for freight**
No other allowances on freight shipped by any other carrier.

NOTE: DISCOUNTS ARE SUBJECT TO CHANGE



STOW CONSTRUCTION EQUIPMENT
A DIVISION OF MULTIQUIP INC.
POST OFFICE BOX 6254
CARSON, CA 90749
310-537-3700 • 888-252-STOW [888-252-7869]
FAX: 310-537-1986 • FAX: 800-556-1986
E-MAIL: stow@multiquip.com • WWW: stowmfg.com

Direct TOLL-FREE access to our Parts Department:

Toll-free nationwide — 800-427-1244

NOTICE TO OPERATORS

IF YOU CAN NOT READ OR DO NOT FULLY UNDERSTAND THE CONTENTS OF THIS MANUAL, PLEASE CONTACT THE FACTORY FOR PROPER ASSISTANCE BEFORE ATTEMPTING TO OPERATE THIS PRODUCT.

SI TU NO PUEDES LE'ER O NO COMPRENDES EL CONTENIDO DE ESTE MANUAL FAVOR DE PONERSE EN CONTACTO CON LA. FABRICA PARA ASISTENCIA- A PROPIA ANTES DE INTENTAR PARA OPERAR ESTE PRODUCTO.

SOLLTEN SIE DIESE GEBRAUCHSANWEISUNG NICHT LESEN KOENNEN ODER ES NICHT VOLLKOMMEN VERSTEHEN, WENDEN SIE SICH BITTE AN DEN HERSTELLER FUER RICHTIGE HILFE EHE SIE VERSUCHEN DIESES PRODUKT ZU OPERIEREN.

SI VOUS NE LISEZ OU NE COMPRENDRE ENTIEREMENT LES MATIERES DE CE MANUEL, S'IL VOUS PLAIT, CONTACTEZ L'USINE POUR L'ASSISTANCE APPROPRIEE AVANT D'UTILISER LE PRODUIT.

 DANGER

 CAUTION

These safety alert symbols identify important safety messages in this manual. When you see these symbols, be alert to the possibility of personal injury and carefully read the message that follows.

Do not allow anyone to operate the FLOOR COVERING SCRAPER without first reading this Operator Manual and becoming familiar with its operation. The manufacturer of the FLOOR COVERING SCRAPER has gone to great extremes to provide the owner(s) and/or operator(s) with the finest equipment available for its intended job function of removing covering materials from concrete and wood floor surfaces. Yet, the possibility exists that the FLOOR COVERING SCRAPER can be utilized in and/or subjected to job applications not perceived and/or anticipated by the manufacturer. Such misuse and/or misapplication of the FLOOR COVERING SCRAPER can lead to the possibility of serious damage, injury or even death. It is the responsibility of the owner(s) and/or operator(s) to determine that the FLOOR COVERING SCRAPER is being utilized and/or operated within the scope of its intended job function. It is the responsibility of the owner(s) and/or operator(s) to establish, monitor and constantly upgrade all safety programs and/or practices utilized in and for the operation of the FLOOR COVERING SCRAPER. The purpose of such programs is to provide for owner(s) and/or operator(s) safety. Operators must be instructed to recognize and avoid unsafe conditions associated with their work (29 CFR 1926.21 (b)(2)) and/or applicable updated revisions. It is the responsibility of the owner(s) and/or operator(s) to determine that no modifications and/or alterations have been made to the FLOOR COVERING SCRAPER. Modifications and/or alterations can lead to the possibility of serious damage, injury or even death. It is the responsibility of the owner(s) and/or operator(s) to make this Operator Manual available for consultation during all phases of operation. Refer to OSHA 2207 and/or applicable updated revisions which contains all OSHA job safety and health rules and regulations (1926 and 1910) covering construction.

⚠ CAUTION

The concept of electrically powered, walk-behind type floor covering removal equipment has been successfully utilized for many years as a practical solution to many types of floor covering removal requirements. The basic concept is proven and well accepted within the associated marketplaces. Use of a FLOOR COVERING SCRAPER requires strenuous work activity. This type of work activity can be considered to be greater in magnitude than that experienced with the use of many other types of both light construction and lawn and garden related equipment. This type of work activity should only be attempted by operators of adequate physical size and stature, mental awareness and physical strength and condition. The body parts most noticeably affected during the covering removal process are the arms, hands, wrists, shoulders, lower back and legs. The process can also produce excessive stress/strain directly to the back muscles, spinal vertebrae and many other body parts. Back and wrist related pain can be side effects of utilizing a FLOOR COVERING SCRAPER. A potential operator with a chronic back related problem or a history of back and/or other medically related problems should not attempt to utilize the FLOOR COVERING SCRAPER. Use of the FLOOR COVERING SCRAPER may only aggravate this and any other medically related problem. Because of the diverse type of prevailing job applications, job site conditions, operator experience levels and operator physical characteristics, no warranty, guarantee, representation and/or liability is made by the manufacturer as to the absolute correctness or sufficiency of any operational procedure, operational position and/or technique. There is no absolute guarantee that an operator of any given experience level, physical size and/or physical condition will be immune to the possibility of and/or probable physical side effects of the normal use of the FLOOR COVERING SCRAPER. Each potential operator must be made aware of and assume the operational and physical liability described and/or associated with the use of the FLOOR COVERING SCRAPER. Improper use of the FLOOR COVERING SCRAPER can result in property damage and/or personal injury, including death. Each potential operator not willing to assume the operational and physical liability described and/or associated with the use of the FLOOR COVERING SCRAPER, should not operate it. Proper levels of operator experience, skill and common sense are essential for maximizing the safe and efficient operation of the FLOOR COVERING SCRAPER.

Record the FLOOR COVERING SCRAPER and electric motor serial numbers in the spaces provided below.

_____ **Model Number**

_____ **Serial Number**

_____ **Electric Motor Serial Number**

_____ **Date of Purchase**

Specifications and design are subject to change without notice or obligation. All specifications are general in nature and are not intended for specific application purposes. General Equipment Company reserves the right to make changes in design, engineering or specifications and to add improvements or discontinue manufacture at any time without notice or obligation. STOW A Division of Multiquip and its agents accept no responsibility for variations which may be evident in actual products, specifications, pictures and descriptions contained in this publication.

OPERATOR INSTRUCTIONAL DATA SHEET

The following undersigned operators of the FLOOR COVERING SCRAPER described and/or pertaining to this Operator Manual have received formal safety and operational information/instruction from the undersigned owner(s)/instructor(s) in accordance to OSHA 29 CFR 1926.21 (b)(2) and/or applicable updated revisions pertaining to, but not necessarily limited to the:

1) **READING, COMPREHENSION AND ACKNOWLEDGEMENT OF THE MATERIAL COMPRISING THE ENTIRE CONTENTS OF THE APPLICABLE OPERATOR MANUAL AND APPLICABLE SAFETY AND OPERATIONAL INFORMATION VIDEO TAPE FOR THE FLOOR COVERING SCRAPER.**

2) **FORMALIZED OPERATOR SAFETY PROGRAM TO BE DEvised BY THE OWNER OF THE FLOOR COVERING SCRAPER IN CONJUNCTION WITH THE CONTENTS OF THE APPLICABLE OPERATOR MANUAL AND THE APPLICABLE SAFETY AND OPERATIONAL INFORMATION VIDEO TAPE FOR THE FLOOR COVERING SCRAPER.**

3) **OSHA RULES AND REGULATIONS RESEARCHED FOR AND/OR BY THE OWNER OF THE FLOOR COVERING SCRAPER AND DEEMED APPLICABLE TO THE SAFE AND PROPER USE AND/OR OPERATION OF THE FLOOR COVERING SCRAPER FOR ANY SPECIFIC JOB APPLICATION.**

4) **LOCAL LAWS, REGULATIONS AND CUSTOMS RESEARCHED FOR AND/OR BY THE OWNER OF THE FLOOR COVERING SCRAPER AND DEEMED APPLICABLE TO THE SAFE AND PROPER USE AND/OR OPERATION OF THE FLOOR COVERING SCRAPER FOR ANY SPECIFIC JOB APPLICATION.**

5) **FORMALIZED MAINTENANCE PROGRAM FOR THE FLOOR COVERING SCRAPER TO BE DEvised BY THE OWNER OF THE FLOOR COVERING SCRAPER IN ACCORDANCE WITH, BUT NOT NECESSARILY LIMITED TO, THE SPECIFICATIONS, GUIDELINES AND OPERATIONAL INFORMATION CONTAINED IN THE APPLICABLE OPERATOR MANUAL.**

6) **COMPREHENSIVE OPERATIONAL INSTRUCTIONS FOR THE CORRECT AND PROPER USE OF THE FLOOR COVERING SCRAPER AS PER THE CONTENTS OF THE APPLICABLE OPERATOR MANUAL AND THE APPLICABLE SAFETY AND OPERATIONAL INFORMATION VIDEO TAPE.**

_____ Operator	_____ Owner/Instructor	_____ Date
_____ Operator	_____ Owner/Instructor	_____ Date
_____ Operator	_____ Owner/Instructor	_____ Date
_____ Operator	_____ Owner/Instructor	_____ Date
_____ Operator	_____ Owner/Instructor	_____ Date
_____ Operator	_____ Owner/Instructor	_____ Date

NOTE: INSERT COPIES OF THIS PAGE WITHIN THE OPERATOR'S MANUAL IF SPACE FOR ADDITIONAL OPERATORS IS REQUIRED.

DANGER

THE FOLLOWING SAFETY PRECAUTIONS PROVIDE SOME COMMON SENSE GUIDES TO PROMOTE SAFETY AND EFFICIENCY WITH THE FLOOR COVERING SCRAPER. NO WARRANTY, GUARANTEE OR REPRESENTATION IS MADE BY THE MANUFACTURER AS TO THE ABSOLUTE CORRECTNESS OR SUFFICIENCY OF ANY INFORMATION OR STATEMENT. THESE SAFETY PRECAUTIONS ARE INTENDED TO DEAL PRINCIPALLY WITH COMMON PRACTICES AND CONDITIONS ENCOUNTERED IN THE USE OF THE FLOOR COVERING SCRAPER AND ARE NOT INTENDED TO BE ALL INCLUSIVE. PROPER LEVELS OF OPERATOR EXPERIENCE, SKILL AND COMMON SENSE ARE ESSENTIAL FOR SAFE AND EFFICIENT OPERATION.

DANGER

THE DUSTS/BYPRODUCTS FROM THE COVERING REMOVAL PROCESS ASSOCIATED WITH THE OPERATION OF THE FLOOR COVERING SCRAPER CAN CONTAIN CHEMICALS KNOWN TO THE STATE OF CALIFORNIA TO CAUSE CANCER, BIRTH DEFECTS OR OTHER REPRODUCTIVE HARM. THIS STATEMENT IS MADE IN COMPLIANCE TO CALIFORNIA PROPOSITION 65.

DANGER

INCORRECT USE OF THE FLOOR COVERING SCRAPER CAN RESULT IN PROPERTY DAMAGE, PERSONAL INJURY OR EVEN DEATH. TO REDUCE THIS POSSIBILITY, GIVE COMPLETE AND UNDIVIDED ATTENTION TO THE JOB AT HAND AND FOLLOW THESE SAFETY PRECAUTIONS:

PREPARATION.

1) The FLOOR COVERING SCRAPER is a specialized type of powered equipment, designed for a specific job function and requires adequate and thorough instruction BEFORE it is operated. The size, power, complexity and operating characteristics of this type of powered equipment would dictate that each operator must receive adequate, professional instruction regarding the proper operation of the FLOOR COVERING SCRAPER before being allowed to utilize it. BEFORE attempting to utilize the FLOOR

COVERING SCRAPER, read this Operator's Manual, and view the applicable

Safety and Operational Information Video Tape to familiarize each operator with its correct operating procedures. Avoid the urge not to take the necessary time to read this Operator's Manual before operating the FLOOR COVERING SCRAPER. DO NOT OPERATE THE FLOOR COVERING SCRAPER UNTIL EACH OPERATOR COMPLETELY COMPREHENDS THE CONTENTS OF THIS MANUAL, THE APPLICABLE SAFETY AND OPERATIONAL INFORMATION VIDEO TAPE AND APPLICABLE SUPPLEMENTAL INFORMATION.

2) Develop a comprehensive program for the safe operation of the FLOOR COVERING SCRAPER by its owner(s) and/or operator(s). Such a program will include, but is not limited to: instructional requirements for operation, applicable OSHA requirements, local laws and regulations, job site safety and a FLOOR COVERING SCRAPER maintenance program. Constantly examine and upgrade this program to guarantee owner(s) and/or operator(s) safety. Each operator must be fully instructed regarding the specifics of this safety program.

3) Determine that the FLOOR COVERING SCRAPER is in its original, factory configuration and has not been modified in any manner. Many modifications can result in potentially dangerous configurations that can lead to property damage and/or personal injury. If there are any questions about possible modifications made to the FLOOR COVERING SCRAPER, contact the Customer Service Department for specific information BEFORE utilization. There is no charge for this service.

4) Minors should never be allowed to operate the FLOOR COVERING SCRAPER. Bystanders, especially children and animals, should not be allowed in the area where the FLOOR COVERING SCRAPER is in use. The covering removal process can result in flying particles being emitted at high velocity and striking the operator and/or onlookers. This can lead to the possibility of property damage and/or personal injury. Keep all body parts, loose clothing, foreign objects and onlookers clear of the rotating auger and/or auger extensions.

5) Operators must be in proper physical condition, mental health and not under the influence of any substance (drugs, alcohol, etc.) which might impair vision, dexterity or judgment. Working with the FLOOR COVERING SCRAPER is strenuous. If you have any condition that might be aggravated by strenuous work, check with your doctor BEFORE operating the FLOOR COVERING SCRAPER. Guard against the possibility

SAFETY PRECAUTIONS

of back related injuries. Always lift the FLOOR COVERING SCRAPER with leg muscles and not with the back.

6) Prolonged use of the FLOOR COVERING SCRAPER (or other, similar machines) exposes the operator to vibrations which may produce Whitefinger Disease (Raynaud's Phenomenon). This phenomenon reduces the hand's ability to feel and regulate temperature, produces numbness and burning sensations and may cause nerve and circulation damage and tissue necrosis. Antivibration systems do not guarantee that you will not sustain Whitefinger Disease. Therefore, continuous and regular users should closely monitor the condition of their hands and fingers. After each period of use, exercise to restore normal blood circulation. If any of the symptoms appear, seek medical advice immediately.

7) Clothing must be sturdy and snug fitting, but allow complete freedom of movement. Never wear loose fitting jackets, scarves, neckties, jewelry, flared or cuffed pants or anything that could become caught on controls or moving parts. Wear long pants to protect your legs. Protect your hands with heavy duty, nonslip gloves to improve your grip. Good footing is most important when operating the FLOOR COVERING SCRAPER. Wear sturdy boots with nonslip soles. Steel-toed safety shoes are highly recommended. Keep shoes properly laced. Never wear tennis shoes or other, similar type shoes which afford little or no protection. Wear an approved safety hard hat to protect the operator(s) head(s) where there is a danger of head injuries. Noise, generated by the operation of the FLOOR COVERING SCRAPER and the actual process itself, can damage your hearing. Wear approved sound barriers (ear plugs or ear muffs) to protect your hearing. Continuous and regular operators should have their hearing checked regularly.

8) Visually inspect the FLOOR COVERING SCRAPER, blade(s), and accessories for damaged or worn parts. Check for loose and/or broken parts. Determine that operator controls work freely, all safety devices are operative and information/safety decals are readable. Check to determine that the FLOOR COVERING SCRAPER and all related accessories are in good mechanical condition BEFORE utilization.

9) The FLOOR COVERING SCRAPER and related accessories are not classified as being insulated. Contact with electrical cables, gas lines and other hazardous items can result in electrocution and/or an explosion.

10) Know how the controls operate. Know how to stop the motor quickly in an emergency. Always start the

motor according to the instructions as outlined in this manual to minimize the possibility of unexpected or uncontrolled blade/accessory oscillation. Unexpected blade/accessory rotation can cause loss of machine control, and the possibility of property damage and/or personal injury.

11) Never exceed the recommended capacities of the FLOOR COVERING SCRAPER. Refer to the **Specifications** section of this manual for more detailed information. Always utilize the correct blade and extension cord designed for use with the FLOOR COVERING SCRAPER. Use of an incorrect blade or extension cord can result in property damage and/or personal injury.

OPERATION.

1) Give complete and undivided attention to the job at hand. Do not chew gum, smoke and/or use smokeless tobacco while utilizing the FLOOR COVERING SCRAPER. Do not attempt to eat and/or drink while utilizing the FLOOR COVERING SCRAPER. Determine that eyeglasses, hearing aid devices and other medical related devices are properly secured. Keep shoes properly laced. Use of the FLOOR COVERING SCRAPER is strenuous and causes fatigue. Help prevent the cause of an accident. Plan to take work breaks as required to help maintain proper mental and physical alertness.

2) The FLOOR COVERING SCRAPER is not sealed or insulated. Do not operate the FLOOR COVERING SCRAPER in an explosive atmosphere or near combustible materials. Refer to current OSHA rules and regulations.

3) The FLOOR COVERING SCRAPER is designed for use by one operator. Use of the FLOOR COVERING SCRAPER by more than one operator can lead to confusion and loss of control, resulting in property damage and/or personal injury. Never operate the FLOOR COVERING SCRAPER with an improper number of operators. Such a configuration can result in property damage and/or personal injury. If it is felt that more than one person is required to furnish additional "force" to the blade, STOP and contact the Customer Service Department for specific operational and service/maintenance information. There is no charge for this service.

4) Do not operate the FLOOR COVERING SCRAPER with onlookers close by. Caution all onlookers to stand clear. The coverings removal process process can result in flying particles being emitted at high velocity and striking the operator and/or onlookers. This can lead to the possibility of property damage and/or

SAFETY PRECAUTIONS

personal injury. Keep all body parts, loose clothing and foreign objects clear of the oscillating blade/accessory

5) Start the motor according to the instructions as outlined in this manual to minimize the possibility of unexpected blade/accessory oscillation. Unexpected blade/accessory oscillation can result in the loss of machine control and the possibility of property damage and/or personal injury.

6) Operate the FLOOR COVERING SCRAPER only when/where visibility and light are adequate for the job at hand. Work carefully. Always hold the operator handle firmly with both hands. Wrap your fingers around the handle grips, keeping them cradled between your thumbs and fingers. Always determine the operator handle is in good condition and free of moisture, pitch, oil or grease. Wear gloves to improve your grip. Never leave the FLOOR COVERING SCRAPER running unattended.

7) Stop the motor while moving and/or repositioning the FLOOR COVERING SCRAPER on the jobsite. Allowing the motor to remain operating substantially increases the potential for property damage and/or personal injury. Special care must be exercised on slippery conditions and on difficult, uneven surfaces. Watch for cracks, high spots and other surface irregularities. Keep proper footing and balance at all times. The normal use of this machine is on level surfaces. Other terrains can be dangerous and should be avoided. Only properly trained operators should attempt these techniques.

8) Because the FLOOR COVERING SCRAPER is classified as a low cost, low horsepower, portable type machine, it is limited in the number of practical and/or suitable job applications. A particular job site, actual surface conditions, job specifications and operator skill/common sense may dictate that a different type of machine (with characteristics of higher purchase cost, being mounted to a carrier vehicle, with greater horsepower and less mobility), method and/or process be utilized to properly complete the job with the degree of efficiency and safety required. Contact the Customer Service Department for specific information regarding suitable job applications, job site surface conditions and operator experience/skill/common sense recommendations for the FLOOR COVERING SCRAPER BEFORE utilization. There is no charge for this service.

MAINTENANCE, REPAIR AND STORAGE.

1) Use only genuine, approved replacement parts and accessories for maintenance and repair. Use of parts

and accessories manufactured by others can result in property damage and/or personal injury.

2) Follow the **Service** instructions as outlined in the appropriate section of this manual.

3) Always stop the motor and disconnect the extension cord BEFORE checking or working on the FLOOR COVERING SCRAPER.

4) Always properly maintain the FLOOR COVERING SCRAPER. Frequently check all fasteners and individual parts. Built in safety features are effective only if they are maintained in good working condition. Replace any questionable part or assembly with a genuine, factory approved, replacement part. Do not forsake proper maintenance for the price of a few replacement parts. Proper maintenance does not cost...it actually pays dividends. Do not attempt any maintenance repair work not described in this manual. Have such work performed at your dealer's service facility.

5) Maintain all safety and operation decals in proper condition. If any decal becomes damaged and/or unreadable, replace with a genuine, factory approved, replacement part only.

6) The FLOOR COVERING SCRAPER may utilize self locking type hexagon head nuts to minimize the effects of vibration. Replace all self locking hardware with genuine, factory approved, replacement parts only.

7) Consult the material supplied by the motor manufacturer for specific information relative to proper operational, lubrication and storage requirements.

ASSEMBLY INSTRUCTIONS/OPERATION

Assembly

The STOW SFCS16 FLOOR COVERING SCRAPER is shipped from the factory secured on a specially designed wooden pallet and protected from external damage by a corrugated carton or wood crate. If shipped with a corrugated carton, the Surface Grinder is secured to the pallet with wood support strips. Remove the carton or crate immediately upon receipt using suitable tools to remove the nails.

REMOVING THE FLOOR COVERING SCRAPER FROM THE PALLET.

Tools Required:

- 1 each, cutting type pliers.
- 1 each, claw hammer or a hammer and an appropriate pry bar.

Remove the corrugated carton which is fastened to the pallet. The FLOOR COVERING SCRAPER is secured to the pallet with banding. Using the pliers, cut and remove the banding. The FLOOR COVERING SCRAPER can then be removed from the pallet.

! DANGER

WEAR SAFETY GLASSES AND OTHER APPROPRIATE SAFETY APPAREL WHEN CUTTING THE BANDING AND/OR REMOVING THE CORRUGATED/WOOD SHIPPING CRATE.

Included in the shipment should be the following:

- 1 each, FLOOR COVERING SCRAPER main frame assembly.
- 1 each, extension cord with integral GFI.
- 1 each, adjustable section of the operator handle.
- 1 each, pack of standard blades.

The FLOOR COVERING SCRAPER is shipped from the factory completely assembled with the exception of the adjustable section of the operator handle. If ordered with the Surface Grinder, optional blades and accessories can be shipped separately or included in the shipping container.

Visually inspect the shipment for freight damage and/or missing parts. If shipping damage is evident, contact the delivering carrier immediately to arrange for an inspection of the damage by its claims representative. Federal law requires that a claim be filed within a specific time period. If missing parts are detected, notify your dealer or the Customer Service Department who will assist you in obtaining them.

Check all fasteners for proper security. Consult a fastener torque chart for the proper torque value if any fastener is found to require retorquing.

INSTALLATION OF THE ADJUSTABLE SECTION OF THE OPERATOR HANDLE.

The installation of the adjustable section of the operator will require a level working surface of sufficient size and appropriate height.

1) The FLOOR COVERING SCRAPER incorporates an operator handle design that folds for transport and storage. The handle is secured to the main frame at two locations; a pivoting (fixed) location secured by Allen head type capscrews and a retaining (locking) location secured by removeable, ball-detent type pins. The pins are secured to the main frame by lanyards.

2) To place the operator handle in the work position, move the handle upright so that the ball-detent pins can be inserted through the operator handle and main frame. Determine the ball-detent pins are properly inserted through the operator handle and main frame to fully expose the ball detent. FIGURE 1.



FIGURE 1

THE BALL DETENT MUST BE FULLY EXPOSED AGAINST THE MAIN FRAME TO PROVIDE THE

! DANGER

PROPER PIN RETAINING FORCE. AN IMPROPER PIN RETAINING CONFIGURATION CAN RESULT IN UNEXPECTED OPERATOR HANDLE MOVEMENT. THIS OCCURRENCE CAN RESULT IN PROPERTY DAMAGE AND/OR PERSONAL INJURY.

3) Remove the threaded knobs from the fixed section of the operator handle. Install the adjustable section into the fixed section with the handle grips facing

ASSEMBLY INSTRUCTIONS/OPERATION

backwards toward the operator. FIGURE 2. Position the adjustable section at a comfortable height. Reinstall the threaded knobs and tighten until the studs trust up tight against the adjustable handle section.

The ergonomic design considerations of the adjustable section of the operator handle will only function if the handle grips are installed facing backwards (toward) the operator. Installing the adjustable section of the operator handle with the handle grips facing forward (away) from the operator will decrease machine control and productivity.

INSTALLING THE ADJUSTABLE SECTION OF THE OPERATOR HANDLE WITH THE HANDLE GRIPS FACING FORWARD (AWAY) FROM THE OPERATOR WILL NOT ALLOW THE THREADED STUDS TO PROPERLY LOCATE WITHIN THE SLOTS OF THE ADJUSTABLE HANDLE. THE SLOT ENDS FORM INTEGRAL STOPS FOR THE THREADED STUDS TO THRUST AGAINST. A PROPER STUD/SLOT CONFIGURATION WILL PREVENT THE ADJUSTABLE HANDLE FROM INADVERTENTLY SEPARATING FROM THE FIXED SECTION WHEN TRAVERSING AN INCLINE SUCH AS A STAIRWAY. INADVERTENT SEPARATION OF THE ADJUSTABLE HANDLE SECTION CAN RESULT IN PROPERTY DAMAGE AND/OR PERSONAL INJURY.

Improper knob tension and/or improperly securing

⚠ CAUTION

the operator handle to the main frame can result in an unstable platform configuration. An unstable platform configuration can result in property damage and/or personal injury.



FIGURE 2

Before Starting the Motor

THEORY OF OPERATION.

The SFCS16 FLOOR COVERING SCRAPER is designed to operate on the principle of various blades and/or attachments oscillating with a random orbital movement to remove a wide variety of covering materials from work surfaces. Various types of multi-accessory blades and/or accessory attachments are secured to the exciter plate located on the bottom of the machine. The specific type of blade and/or accessory attachment utilized directly affects the type of material removed, the material removal rate and the resulting smoothness of the work surface.

The coverings removal process is directly controlled by these conditions:

- 1) The use of a suitable mechanism (blade or accessory attachment) of proper design and configuration to scrape against the work surface and remove material while delivering an acceptable service life.
- 2) Sufficient static weight supporting the blade or accessory attachment to allow it to effectively penetrate and remove the covering material.
- 3) Adequate force exerted against the FLOOR COVERING SCRAPER by the operator that pushes the blade or accessory attachment against the covering material to deliver acceptable productivity rates.
- 4) Since no two covering materials are exactly alike, no two covering materials can be removed by the exact same method. The nature of the covering removal process, along with operator experience, skill

ASSEMBLY INSTRUCTIONS/OPERATION

and common sense, would suggest that efficient and productive material removal is a matter of trial and error. Combinations of blade or accessory attachment type, jobsite conditions, and feed rates are direct factors that will also determine the overall success of the job application.

BLADE CONFIGURATIONS, ACCESSORY ATTACHMENTS AND APPLICATIONS.

FLOOR COVERING SCRAPER blades are fabricated from high carbon steel, precision machined and heat treated for extended service life. Blades are marked to depict use on either concrete or wood surfaces. When utilized on concrete, the cutting edge is positioned facing up. FIGURE 3. On wood flooring surfaces, the cutting edge faces down against the surface. FIGURE 4. This configuration allows the blade to skim over the surface and minimize any tendency to gouge or dig into the wood. A slotted blade configuration is employed to lower installation and removal time. The slotted configuration is also intended to help minimize direct exposure of hands, arms and other body parts to the blade during the installation or removal process.

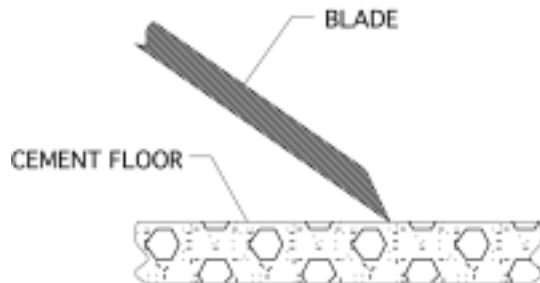

FIGURE 3

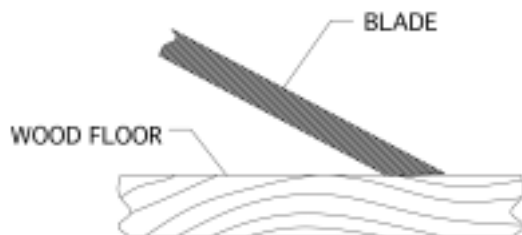

FIGURE 4

A protective covering is provided to protect the blade cutting edge from external damage and minimize the potential for property damage and/or personal injury.

Store the blade with the protective covering properly installed to minimize the effects of external damage to the cutting edge and the potential for property damage and/or personal injury.

! DANGER

THE BLADE IS EXTREMELY SHARP. IMPROPER HANDLING WHILE REMOVING FROM THE PACKAGE, REMOVING/REINSTALLING THE PROTECTIVE CUTTING EDGE COVER, INSTALLING/REMOVING FROM THE MACHINE OR

! CAUTION

WHILE IMPROPERLY TRANSPORTING CAN RESULT IN PROPERTY DAMAGE AND/OR PERSONAL INJURY.

While individual blade or accessory attachment design and configuration may vary, basic operational characteristics are identical: impact against a floor surface and remove the covering material. This common operational characteristic has led to the development of the following popular blade configurations and accessory attachments:

Angled Mastic Removal Blade.

This blade configuration is utilized to remove a wide variety of adhesives, mastics and material residues from concrete surfaces. The steep angle increases the cutting edge position relative to the floor surface. The angle increase allows the blade to better penetrate the material and then shear and scrape it from the floor surface. The cutting edge faces down toward the floor surface. Angled mastic blades are utilized on concrete surfaces only. Use on wood surfaces will only dig into and remove substrate material. FIGURE 5.



FIGURE 5

Straight Beveled Cutting Edge Blade.

This blade configuration is utilized to remove a wide variety of VCT and linoleum tiles along with general material removal from concrete and wood surfaces. Some blades feature two cutting edges. Position the blade edge facing up for use on concrete surfaces. Flip the blade over for use on wood surfaces. Specific blades are available for removing covering materials from either concrete or wood surfaces. This blade design does not allow it to be flipped over for use on both concrete and wood surfaces. FIGURE 6.



FIGURE 6

Straight Beveled Scoring Blades.

This blade configuration is utilized to remove glued type carpet and soft sheet type (PVC, rubber, linoleum, etc) materials from concrete and wood surfaces. FIGURE 7. The cutting wings score the covering material to aid in removal. Specific part numbers are available for removing covering materials from either concrete or wood surfaces. The blade design does not allow it to be flipped over for use on both concrete and wood surfaces.

⚠ CAUTION

Use of a straight beveled scoring blade with the cutting wings positioned down and against the work surface can result in unrepairable surface damage and personal injury.



ASSEMBLY INSTRUCTIONS/OPERATION

FIGURE 7

Ceramic tile ripper attachment.

This attachment is designed for light to medium duty projects requiring the removal of ceramic, thicker VCT and linoleum tiles, hardwood floors, etc, from concrete and wood surfaces. FIGURE 8.



FIGURE 8

⚠ CAUTION

The primary design function for the FLOOR COVERING SCRAPER is not to remove ceramic tile. Removing ceramic tile is a secondary job application that may require the use of a machine and/or process with significant greater stability, power and/or impact force. The FLOOR COVERING SCRAPER has demonstrated the ability to remove ceramic tile for those job applications classified as light to medium duty. An improper job application for the FLOOR COVERING SCRAPER may result in property damage and/or personal injury.

INSTALLING A BLADE OR THE CERAMIC TILE RIPPER ATTACHMENT TO THE FLOOR COVERING SCRAPER.

Tools required: 1 each, 5/32 inch T handled Allen wrench provided with the machine.

Parts required: 1 each, blade appropriate for the job application or the ceramic tile ripper attachment.

⚠ DANGER

WHEN INSTALLING OR REMOVING A BLADE OR THE CERAMIC TILE RIPPER ATTACHMENT TO/FROM THE FLOOR COVERING SCRAPER ALWAYS WEAR THE APPROPRIATE SAFETY EYEWEAR, GLOVES, LEATHER SHOES AND LONG PANTS TO MAXIMIZE PERSONAL PROTECTION FROM THE SHARP EDGE (S). IMPROPER CONTACT WITH A SHARP EDGE CAN RESULT IN PROPERTY DAMAGE AND/OR PERSONAL INJURY.

1) Properly disconnect the extension cord or the FLOOR COVERING SCRAPER from the power source.

2) To place the operator handle in the work position, move the handle upright so that the ball-detent pins can be inserted through the operator handle and main frame. Determine the ball-detent pins are inserted through the operator handle and main frame to fully expose the ball detent. FIGURE 9.



FIGURE 9

⚠ DANGER

THE BALL DETENT MUST BE FULLY EXPOSED

⚠ DANGER

AGAINST THE MAIN FRAME TO PROVIDE THE PROPER PIN RETAINING FORCE. AN IMPROPER PIN RETAINING CONFIGURATION CAN RESULT IN UNEXPECTED OPERATOR HANDLE MOVEMENT. THIS OCCURRENCE CAN RESULT IN PROPERTY DAMAGE AND/OR PERSONAL INJURY.

3) Loosen the threaded handle knobs and extend the operator handle out until the internal handle stops

thrust against the threaded studs. Retighten the knobs. FIGURE 10.



FIGURE 10

⚠ CAUTION

Improper knob tension and/or improperly securing the operator handle to the main frame can result in an unstable platform configuration. An unstable platform configuration can result in property damage and/or personal injury.

4) Tilt the FLOOR COVERING SCRAPER back until the operator handle comes in contact with the surface. The FLOOR COVERING SCRAPER may not be in a stable position in this configuration. To minimize the possibility of property damage and/or personal injury, properly secure an appropriate weight to the handle for added stability. Other means can also be utilized to support the frame and provide proper machine stability. Appropriate wheel chocks are also recommended. FIGURE 11.

EXERCISE EXTREME CAUTION WHEN WORKING NEAR OR UNDER THE FLOOR COVERING SCRAPER WITH THE OPERATOR HANDLE TILTED BACK IN THE SERVICE POSITION. IF THE FLOOR COVERING SCRAPER IS NOT POSITIONED IN A STABLE CONFIGURATION, WITH ADEQUATE COUNTERWEIGHT PROPERLY SECURED, UNEXPECTED MOVEMENT CAN ALLOW THE MACHINE TO FALL BACK TO THE WORK SURFACE. THIS OCCURRENCE CAN RESULT IN PROPERTY DAMAGE AND/OR PERSONAL INJURY.

FIGURE 11

5) Wear proper safety apparel and equipment. Use the T-handled Allen wrench to loosen the button head cap screws which secure the fence plate to the exciter plate. This will allow the blade to slide in between the fence plate and the exciter plate. **IT IS NOT NECESSARY TO REMOVE THE FENCE PLATE FROM THE EXCITER PLATE.** The fence plate has an integral stop which the edge of the blade thrusts up against. FIGURE 12. Blades are provided with a covering that protects the cutting edge. Do not remove the protective covering until you are ready to operate the FLOOR COVERING SCRAPER. Exercise extreme caution when removing and/or reinstalling the protective cover.



FIGURE 12



ASSEMBLY INSTRUCTIONS/OPERATION

6) Two attachment configurations for blades are utilized. Narrow (less than 6 inches (152 mm) wide) blades are positioned between the two button head capscrews and thrust up against the fence plate stop. FIGURE 13. Use the T-handled Allen wrench to tighten the button head screws. Wider (greater than 6 inches (152 mm) wide) blades incorporate a slotted design which slides around the button head capscrews. The slots afford increased clamping pressure for the wider blades during the covering removal process. SLOTS ALSO MAKE IT UNNECESSARY TO REMOVE THE FENCE PLATE FROM THE EXCITER PLATE. Use the T-handled Allen wrench to tighten the button head capscrews. FIGURE 13. If the FLOOR COVERING SCRAPER is to be utilized immediately, remove the protective cover from the blade. If the FLOOR COVERING SCRAPER is not be utilized immediately, do not remove the protective covering from the blade.



FIGURE 13

7) The installation of the ceramic tile ripper attachment is similar to that of a blade with the exception that the fence plate is removed the exciter plate. The ceramic tile ripper attachment fastens directly to the exciter plate. Follow the same tightening procedure as with a blade. FIGURE 14.



FIGURE 14

⚠ CAUTION

For all blades and the ceramic tile ripper attachment, tighten the button head capscrews with the T-handled Allen wrench provided. Do not utilize another wrench type and/or configuration. The T-handled Allen wrench was chosen to place body parts a practical distance from the blade during the fastener tightening and loosening process. Do not apply excessive impact force to the button head capscrews. Ample seating torque can be applied by the T-handled Allen wrench and normal arm strength levels. Excessive impact force can cause the T-handled Allen wrench to slip out of the button head capscrew, resulting in property damage and/or personal injury.

⚠ CAUTION

Do not substitute a different fastener type for the button head capscrew configuration. The button head configuration was chosen for operational considerations. The use of another fastener types can increase the potential for property damage and/or personal injury.

⚠ DANGER

BLADES ARE EXTREMELY SHARP. CONTACT WITH THE BLADE CAN RESULT IN PROPERTY DAMAGE AND/OR PERSONAL INJURY. BLADES ARE PROVIDED WITH A PROTECTIVE COVER OVER THE CUTTING EDGE. EXERCISE EXTREME CAUTION WHEN REMOVING AND/OR REINSTALLING THE PROTECTIVE COVER. STORE THE BLADE WITH THE PROTECTIVE COVER PROPERLY INSTALLED TO MINIMIZE THE POTENTIAL FOR BLADE DAMAGE AND/OR PERSONAL INJURY.

8) Return the FLOOR COVERING SCRAPER to its normal operating position.

9) Determine that the ON/OFF switch located on the operator handle is in the OFF position. If the FLOOR COVERING SCRAPER is to be used immediately, then reconnect the extension cord or FLOOR COVERING SCRAPER to the power source.

! DANGER

UNEXPECTED MACHINE START UP CAN RESULT IN PROPERTY DAMAGE AND/OR PERSONAL INJURY.

REMOVING THE BLADE OR CERAMIC TILE RIPPER ATTACHMENT FROM THE FLOOR COVERING SCRAPER.

Tools Required: 1 each, 5/32 inch T-handled Allen wrench provided with the machine.

! DANGER

WHEN INSTALLING OR REMOVING A BLADE OR THE CERAMIC TILE RIPPER ATTACHMENT TO/FROM THE FLOOR COVERING SCRAPER, ALWAYS WEAR THE APPROPRIATE SAFETY EYEWEAR, GLOVES, LEATHER SHOES AND LONG PANTS TO MAXIMIZE PERSONAL PROTECTION FROM THE SHARP EDGE(S). IMPROPER CONTACT WITH A SHARP EDGE CAN RESULT IN PROPERTY DAMAGE AND/OR PERSONAL INJURY.

1) Properly disconnect the extension cord or the FLOOR COVERING SCRAPER from the power source.

2) To place the operator handle in the work position, move the handle upright so that the ball-detent pins can be inserted through the operator handle and main frame. Determine the ball-detent pins are inserted through the operator handle and main frame to fully expose the ball detent. FIGURE 15

FIGURE 15

! DANGER

THE BALL DETENT MUST BE FULLY EXPOSED AGAINST THE MAIN FRAME TO PROVIDE THE PROPER PIN RETAINING FORCE. AN IMPROPER PIN RETAINING CONFIGURATION CAN RESULT IN UNEXPECTED OPERATOR HANDLE MOVEMENT. THIS OCCURRENCE CAN RESULT IN PROPERTY DAMAGE AND/OR PERSONAL INJURY.

3) Loosen the threaded handle knobs and extend the operator handle out until the internal handle stops thrust against the treaded studs. Retighten the knobs. FIGURE 16.

! CAUTION

Improper knob tension and/or improperly securing the operator handle to the main frame can result in an unstable platform configuration. An unstable platform configuration can result in property damage and/or personal injury.



FIGURE 16

4) Tilt the FLOOR COVERING SCRAPER back until the operator handle comes in contact with the surface.



ASSEMBLY INSTRUCTIONS/OPERATION

The FLOOR COVERING SCRAPER may not be in a stable position in this configuration. To minimize the possibility of property damage and/or personal injury, properly secure an appropriate weight to the handle for added stability. Other means can also be utilized to support the frame and provide proper machine stability. Appropriate wheel chocks are also recommended. FIGURE 17.



FIGURE 17

⚠ DANGER

EXERCISE EXTREME CAUTION WHEN WORKING NEAR OR UNDER THE FLOOR COVERING SCRAPER WITH THE OPERATOR HANDLE TILTED BACK IN THE SERVICE POSITION. IF THE FLOOR COVERING SCRAPER IS NOT POSITIONED IN A STABLE CONFIGURATION, WITH ADEQUATE COUNTERWEIGHT PROPERLY SECURED, UNEXPECTED MOVEMENT CAN ALLOW THE MACHINE TO FALL BACK TO THE WORK SURFACE. THE RESULT CAN BE PROPERTY DAMAGE AND/OR PERSONAL INJURY.

5) Reinstall the protective blade cover. Exercise extreme caution when removing and/or reinstalling the protective cover. Use the T-handled Allen wrench to loosen the button head capscrews which secure the blade between the fence plate and exciter plate. Remove the blade and store in an appropriate location. Use the T-handled Allen wrench to tighten the button head capscrews. Keep the button head capscrews tight to minimize becoming lost.

6) The removal of the ceramic tile ripper attachment is similar to that of a blade with the exception that the fence plate is reinstalled to the exciter plate. Follow the same tightening procedure as with a blade.

⚠ CAUTION

For all blades and the ceramic tile ripper attachment, tighten the button head capscrews only with the T-handled Allen wrench provided. Do not utilize another wrench type and/or configuration. The T-handled Allen wrench was chosen to place body parts a practical distance from the blade during the fastener tightening and loosening process. Do not apply excessive impact force to the button head cap screws. Ample seating torque can be applied by the T-handled Allen wrench. Excessive impact force can cause the T-handled Allen wrench to slip out of the button head capscrew, resulting in property damage and/or personal injury.

⚠ CAUTION

Do not substitute a different fastener type for the button head capscrew configuration. The button head configuration was chosen for operational considerations. The use of other fastener types can increase the potential for property damage and/or personal injury.

⚠ DANGER

BLADES ARE EXTREMELY SHARP. CONTACT WITH THE BLADE CAN RESULT IN PROPERTY DAMAGE AND/OR PERSONAL INJURY. BLADES ARE PROVIDED WITH A PROTECTIVE COVER OVER THE CUTTING EDGE. EXERCISE EXTREME CAUTION WHEN REMOVING AND/OR REINSTALLING THE PROTECTIVE COVER. STORE THE BLADE WITH THE PROTECTIVE COVER PROPERLY INSTALLED TO MINIMIZE THE POTENTIAL FOR BLADE DAMAGE AND/OR PERSONAL INJURY.

7) Return the FLOOR COVERING SCRAPER to its normal operating position.

8) Determine that the ON/OFF switch located on the operator handle is in the OFF position. IF the FLOOR COVERING SCRAPER is to be used immediately, then reconnect the extension cord or FLOOR COVERING SCRAPER to the power source.

⚠ DANGER

UNEXPECTED MACHINE START UP CAN RESULT IN PROPERTY DAMAGE AND/OR PERSONAL INJURY.

ASSEMBLY INSTRUCTIONS/OPERATION

Operation

OPERATIONAL DISCLAIMER.

THE MANUFACTURER OF THE FLOOR COVERING SCRAPER MAKES NO WARRANTY OR GUARANTEE THAT IT IS MERCHANTABLE AND/OR SUITABLE FOR ANY SPECIFIC JOB APPLICATION AND THAT IT WILL HAVE THE CAPABILITY AND POWER REQUIRED TO REMOVE ANY SPECIFIC COVERING FROM ANY SPECIFIC WORK SURFACE.

CALIFORNIA PROPOSITION 65 DISCLAIMER.

DANGER

THE DUSTS/BYPRODUCTS FROM THE COVERING REMOVAL PROCESS ASSOCIATED WITH THE OPERATION OF THE FLOOR COVERING SCRAPER CAN CONTAIN CHEMICALS KNOWN TO CAUSE CANCER, BIRTH DEFECTS, OR OTHER REPRODUCTIVE HARM.

INFORMATION RELATIVE TO MINIMUM COMPONENT STANDARDS FOR THE OPERATION OF THE FLOOR COVERING SCRAPER.

For operational safety and overall productivity considerations, it is required that specific FLOOR COVERING SCRAPER components meet minimum acceptable operational standards BEFORE utilization:

- 1) Operator handle be properly mounted to the main frame, with factory supplied ball-detent type retaining pins that properly secure the handle to the main frame while in the work position.
- 2) The operator handle is equipped with properly fitting handle grips of sufficient integrity to allow for proper job function as outlined within this manual. Loose fitting handle grips or grips without full end caps are not permitted.
- 3) An ON/OFF motor switch that allows it to perform its intended job function as outlined within this manual. Replace any damaged ON/OFF motor switch with a factory approved replacement part only.
- 4) An extension cord and GFI that allows this accessory to perform its intended job function as outlined within this manual. Replace any damaged extension cord or GFI with a factory approved replacement part only.

5) Exciter plate elastomeric rubber mounts which allow them to perform their intended job function as outlined within this manual. Do not operate the FLOOR COVERING SCRAPER without the correct number of exciter plate elastomeric rubber mounts. Do not operate the FLOOR COVERING SCRAPER with a damaged and/or improperly secured rubber mount. Replace any damaged rubber mount with a factory approved replacement part only.

6) Blade(s) and/or ceramic tile ripper attachment of proper structural integrity (void of cracks, etc), straightness, sharpness, etc which are retained by the proper fasteners. Replace worn or damaged blades, fasteners and the ceramic tile ripper attachment with a factory approved replacement part only.

7) All safety decals, Operator Manual and operational information decals (including the applicable Quik Tips information) must be in proper and readable condition. Replace any missing or damaged safety decal, Operator Manual and/or information decal with a factory approved replacement part only.

TRANSPORTING THE FLOOR COVERING SCRAPER.

The FLOOR COVERING SCRAPER has an operational weight that prohibits one person from loading and/or unloading it alone by conventional, physical efforts.

DANGER

DO NOT ATTEMPT TO LIFT THE FLOOR COVERING SCRAPER UP INTO A TRANSPORTATION VEHICLE WITH THE USE OF ONE PERSON ALONE. DO NOT ATTEMPT TO LOWER THE FLOOR COVERING SCRAPER FROM A TRANSPORTATION VEHICLE WITH THE USE OF ONE PERSON ALONE. LIFT AND/OR LOWER THE FLOOR COVERING SCRAPER ONLY BY THE USE OF A POWER TAILGATE UNIT, A SUITABLE HOIST UNIT OF PROPER CAPACITY AND/OR CONFIGURATION OR BY THE USE OF A PROPER QUANTITY OF PERSONNEL IN PROPER PHYSICAL/MENTAL CONDITION.

1) The FLOOR COVERING SCRAPER can be hoisted by a mechanical device incorporating a chain and suitable attachment device to the lifting bail area located behind the electric motor. FIGURE 18. This location may not always locate the exact position of the center of gravity for the FLOOR COVERING SCRAPER. Lifting handles are also provided on both sides of the main frame. These handles can be

ASSEMBLY INSTRUCTIONS/OPERATION

utilized by personnel whenever lifting/lowering the FLOOR COVERING SCRAPER. FIGURE 19.



FIGURE 18

! DANGER

EXERCISE EXTREME CAUTION WHEN UTILIZING A MECHANICAL DEVICE FOR LIFTING THE FLOOR COVERING SCRAPER. UTILIZE THE MECHANICAL DEVICE IN ACCORDANCE TO BOTH ITS DESIGNED STATIC AND DYNAMIC LOADING ENVELOPES. DO NOT UTILIZE THE MECHANICAL DEVICE UNTIL THIS INFORMATION IS PROPERLY KNOWN AND UNDERSTOOD BY ALL APPLICABLE PERSONNEL. FAILURE TO PROPERLY UTILIZE THE MECHANICAL DEVICE CAN RESULT IN PROPERTY DAMAGE AND/OR PERSONAL INJURY.

! CAUTION

Do not drop the FLOOR COVERING SCRAPER directly upon the exciter plate. Direct impact against the exciter plate can result in damage to components including the plate, elastomeric rubber mounts, electric motor shaft, bearings, etc.



FIGURE 19

2) To minimize the possibility of damage to the FLOOR COVERING SCRAPER, always transport in its normal, upright position. All equipment must be secured in/on vehicles with suitable strapping or tie-downs. Personnel should not be transported in the same compartment as equipment. Consult applicable OSHA and transportation regulations (local, State and Federal) for the proper transportation of the FLOOR COVERING SCRAPER.

3) Do not transport the FLOOR COVERING SCRAPER with a blade or the ceramic tile ripper attachment attached to the main frame in the following configurations:

- a) To and from the jobsite.
- b) For longer distances while being repositioned on the jobsite.
- c) When traversing up and down stairways.
- d) While performing maintenance and/or repairs.
- e) Lifting up/into or/down from a transporting vehicle.

Remove the blade or ceramic tile ripper attachment according to the procedures as outlined in this manual for the above listed configurations.

! DANGER

LIFTING, LOWERING AND TRANSPORTING THE FLOOR COVERING SCRAPER WITH A BLADE OR CERAMIC TILE RIPPER ATTACHMENT INSTALLED CAN RESULT IN PROPERTY DAMAGE AND/OR PERSONAL INJURY.

4) When transporting to and from the jobsite, block the bottom of the main frame to prevent direct impact blows against the exciter plate. This procedure will reduce impact loads directly to the elastomeric rubber mounts, minimize their deflection and increase service life.

ADJUSTING THE OPERATOR HANDLE HEIGHT.

ADJUSTING THE OPERATOR HANDLE HEIGHT.

The FLOOR COVERING SCRAPER incorporates a handle that can be adjusted to compensate for variances in operator height. Handle height can be infinitely varied between the stop limits. No external tools are required. Correct handle height can increase overall machine productivity and reduce operator fatigue.

ASSEMBLY INSTRUCTIONS/OPERATION

1) Loosen the handle knobs located at the rear of the handle. Extend the knobs out approximately 1/2 inch (13 mm). FIGURE 20.



FIGURE 20

2) Position the operator handle grips at a height convenient to the specific operator. In most configurations, the operator handle grips will be at approximately belt height.

3) Tighten the handle knobs finger tight. Determine the adjustable section of the operator handle is properly secured tight against the fixed section.

⚠ CAUTION

Improper knob tension and/or improperly securing the operator handle to the main frame can result in an unstable platform configuration. An unstable platform configuration can result in property damage and/or personal injury.

⚠ DANGER

DETERMINE THE THREADED STUDS ARE PROPERLY SEATED AGAINST THE SLIDING SECTION OF THE OPERATOR HANDLE. THE ADJUSTABLE SECTION MUST BE FIRMLY SECURED TIGHT AGAINST THE FIXED SECTION OF THE OPERATOR HANDLE. IMPROPERLY SECURED STUDS CAN RESULT IN INADVERTENT OPERATOR HANDLE MOVEMENT AND/OR SEPARATION, RESULTING IN PROPERTY DAMAGE AND/OR PERSONAL INJURY

STARTING THE FLOOR COVERING SCRAPER ON THE JOBSITE.

1) Position the FLOOR COVERING SCRAPER on a flat and level surface of firm foundation.

2) Install a blade or the ceramic tile ripper attachment per the procedures as outlined in this manual.

3) Determine that the ON/OFF switch located on the operator handle is in the OFF position.

⚠ DANGER

UNEXPECTED MACHINE START UP CAN RESULT IN PROPERTY DAMAGE AND/OR PERSONAL INJURY.

4) The FLOOR COVERING SCRAPER is designed to operate from a clean, 15 ampere, 115 VAC, 60 Hz, nominal power source. A clean power source refers to the amperage available from the individual electrical circuit selected. Additional electrical products already utilizing the same circuit will reduce the available amperage, and can result in starting and operational difficulties.

⚠ CAUTION

Operating the Surface Grinder from a power source of improper voltage and/or amperage will result in unreparable damage to the electric motor and related controls.

5) Providing proper voltage and amperage levels to the electric motor is essential to obtain maximum productivity and service life. Low voltage and amperage levels will cause the motor to overheat. The motor is equipped with automatic thermal protection device that will stop it before major internal damage can result. After the motor has cooled to an acceptable temperature level, the switch must be manually activated to restart. FIGURE 21.



ASSEMBLY INSTRUCTIONS/OPERATION

FIGURE 21

6) The FLOOR COVERING SCRAPER utilizes a factory supplied extension cord equipped with an integral GFI device. The GFI device is intended to protect both the operator and electric motor in the event a ground fault is developed during operation. The extension cord is 37 foot (11 m) long, fabricated from 12 AWG wire and incorporates a NEMA 5-15P plug and a NEMA L5-15R twist lock type receptacle. The twist lock feature allows the extension cord to be pulled by the FLOOR COVERING SCRAPER without becoming disconnected.

accomplished with proper testing equipment and procedures. If there are any questions regarding the suitability of a specific power receptacle, contact your dealer or our Customer Service Department for assistance BEFORE utilizing the FLOOR COVERING SCRAPER. There is no charge for this service. A qualified electrician may need to be consulted.

8) If additional extension cord length is required for a specific job application, an additional extension cord can be utilized in conjunction with an external GFI. Plug the receptacle of the additional extension cord into the factory supplied GFI. Plug the ground fault circuit interrupter into the power source receptacle. Connect the extension cord plug into the external GFI. This configuration will allow any fault over the length of a defective extension cord to be indicated. Extension cord gauge size and length must conform to National Electric Code standards.

⚠ DANGER

BEFORE USE, PROPERLY INSPECT THE EXTENSION CORD AND WIRING DEVICES FOR STRUCTURAL INTEGRITY. DO NOT UTILIZE A CORD WITH A WORN OR CUT OUTER JACKET MATERIAL. DO NOT UTILIZE A CORD WITH EXPOSED INNER WIRES OR INSULATION MATERIAL. DO NOT UTILIZE A CORD THAT HAS BEEN REPAIRED WITH ELECTRICAL TAPE. DO NOT UTILIZE A CORD WITH A CRACKED AND/OR DAMAGED GFI CASE. USE OF AN EXTENSION CORD OF IMPROPER STRUCTURAL INTEGRITY AND/OR DAMAGED GFI CAN RESULT IN PROPERTY DAMAGE AND/OR PERSONAL INJURY.

⚠ DANGER

ALL ELECTRICAL WIRING, INCLUDING EXTENSION CORD GAUGE SIZE AND/OR LENGTH, MUST BE INSTALLED AND/OR APPROVED IN ACCORDANCE TO LOCAL ELECTRICAL CODES AND PRACTICES. AN IMPROPER WIRING INSTALLATION CAN RESULT IN PROPERTY DAMAGE AND/OR PERSONAL INJURY.

7) Determine that the power source receptacle to be utilized is properly grounded. This can be

⚠ DANGER

FOR MAXIMUM PROTECTION AGAINST A FAULT, ALWAYS CONFIGURE A GROUND FAULT CIRCUIT INTERRUPTER TO BE PLUGGED INTO THE POWER SOURCE RECEPTACLE. A CONFIGURATION WITH THE GROUND FAULT CIRCUIT INTERRUPTER PLACED BETWEEN THE FLOOR COVERING SCRAPER AND THE POWER SOURCE RECEPTACLE WILL NOT AFFORD MAXIMUM PROTECTION AGAINST A POTENTIAL FAULT.

9) Couple the NEMA L5-15R receptacle of the factory supplied extension cord and the NEMA L5-15P plug located on the FLOOR COVERING SCRAPER together. Twist to lock. FIGURE 22. Connect the GFI to the power source receptacle.

10) Grasp the operator handle with firm gripping. When starting the electric motor, apply a down force directly to the operator handle to help reduce the amount of static machine weight against the work surface. The blade or ceramic tile ripper attachment should remain in contact with the surface. Turn the ON/OFF switch to the ON position. Reduce the amount of applied down force on the operator handle as the electric motor attains its operational speed.



FIGURE 22

11) The FLOOR COVERING SCRAPER is not equipped with a centrifugal clutch assembly. The electric motor is directly coupled to the exciter plate. The exciter plate will begin to move when the electric motor starts.

DANGER

AS SOON AS THE ELECTRIC MOTOR HAS STARTED, THE OPERATOR MUST BE IN A POSITION TO ASSUME DIRECT AND FULL CONTROL OF THE FLOOR COVERING SCRAPER. FAILURE TO ASSUME DIRECT AND FULL CONTROL CAN RESULT IN PROPERTY DAMAGE AND/OR PERSONAL INJURY.

12) The FLOOR COVERING SCRAPER is stopped by moving the ON/OFF switch located on the operator handle to the OFF position. For safety considerations, it is also recommended that the extension cord be disconnected from both the FLOOR COVERING SCRAPER and power source receptacle whenever the FLOOR COVERING SCRAPER is not in use on the job site.

DANGER

IF THE FLOOR COVERING SCRAPER IS EQUIPPED WITH A TOGGLE TYPE ON/OFF SWITCH THE MOTOR CAN RESTART IF THE ON/OFF SWITCH IS NOT MOVED TO THE OFF POSITION WHEN THE POWER SOURCE LOOSES POWER AND THEN BECOMES RE-ENERGIZED.

13) If the FLOOR COVERING SCRAPER is equipped with a magnetic start (push button) type ON/OFF switch, the motor will not restart if the power source loses power and then becomes re-energized unless the OFF button is first pushed.

CAUTION

If the FLOOR COVERING SCRAPER and/or an individual component/accessory does not appear to be functioning properly, STOP and do not further operate the FLOOR COVERING SCRAPER until the proper corrective action has been completed. If there are any questions regarding the proper operation of the FLOOR COVERING SCRAPER, contact the Customer Service Department BEFORE further utilization. There is no charge for this service.

OPERATING THE FLOOR COVERING SCRAPER ON THE JOBSITE.

DANGER

THE COVERINGS REMOVAL PROCESS CAN PRODUCE EXCESSIVE NOISE, VIBRATION AND FLYING DEBRIS. ALL OPERATORS AND WORK PERSONNEL IN THE VICINITY OF THE FLOOR COVERING SCRAPER MUST WEAR APPROPRIATE SAFETY EYE WEAR AND HEARING PROTECTION DEVICES. OTHER SAFETY APPAREL AND/OR PROCEDURES, DEEMED NECESSARY BY SUPERVISORY PERSONNEL MUST ALSO BE WORN AND/OR PRACTICED BY ALL APPROPRIATE PERSONNEL.

1) The FLOOR COVERING SCRAPER utilizes an offset weight design (termed the exciter) that moves the blade or ceramic tile ripper attachment with a random orbit oscillation. This design configuration substantially enhances machine control and reduces fatigue as long as the blade or ceramic tile ripper attachment does not come in direct contact with a protruding obstruction from the floor. Direct contact with such an obstruction can result in rapid and jerky directional movement of the machine. This occurrence can lead to loss of machine control, property damage and/or personal injury. In most operating situations, direct contact with a protruding obstruction from the work

ASSEMBLY INSTRUCTIONS/OPERATION

surface will, at a minimum, result in damage to the blade and/or ceramic tile ripper attachment.

be secured to the machine with the use of longer length carriage bolts. FIGURE 24.

⚠ DANGER

EXERCISE EXTREME CAUTION WHEN OPERATING THE FLOOR COVERING SCRAPER IN THE VICINITY OF ANCHOR BOLTS, PIPES, COLUMNS, OPENINGS, PROTRUDING NAIL HEADS, LARGE CRACKS, UTILITY OUTLETS OR ANY OBJECT PROTRUDING FROM THE WORK SURFACE. CONTACT WITH SUCH OBJECTS CAN LEAD TO LOSS OF MACHINE CONTROL, RESULTING IN PROPERTY DAMAGE AND/OR PERSONAL INJURY.

⚠ DANGER

ALWAYS MAINTAIN PROPER CONTROL OF THE FLOOR COVERING SCRAPER. IF AN OPERATOR LOOSES CONTROL OF THE MACHINE, A "RUNAWAY" FLOOR COVERING SCRAPER CAN RESULT IN PROPERTY DAMAGE AND/OR PERSONAL INJURY. BECAUSE OF THE UNIQUE OPERATING CHARACTERISTICS OF THE FLOOR COVERING SCRAPER, THERE IS NO PROVISION FOR THE ELECTRIC MOTOR TO AUTOMATICALLY STOP IF THE OPERATOR FAILS TO MAINTAIN PROPER CONTROL.

⚠ DANGER

WHEN OPERATING THE FLOOR COVERING SCRAPER ON ABOVE GROUND FLOOR LEVELS, EXERCISE EXTREME CAUTION TO PREVENT LOSS OF CONTROL THAT COULD ALLOW THE MACHINE AND/OR OPERATOR TO FALL DOWN TO LOWER LEVELS. SUCH AN OCCURRENCE CAN RESULT IN PROPERTY DAMAGE AND/OR PERSONAL INJURY. WHEN WALKING BACKWARDS DURING THE COVERING REMOVAL PROCESS, BE AWARE OF DROP OFFS AND OBSTRUCTIONS.

2) Productivity rates with the various blade and/or attachments can be increased with the addition of external weight being applied to the front of the machine. FIGURE 23. Each external weight block weighs 14 lbs (6.3 kg). Maximum allowable external weight permits the use of three blocks or 42 lbs (19 kg). Exceeding this figure can result in permanent structural damage to the FLOOR COVERING SCRAPER. The additional external weight blocks can



FIGURE 23



FIGURE 24

⚠ DANGER

DO NOT OPERATE THE FLOOR COVERING SCRAPER WITHOUT ALL EXTERNAL WEIGHT PROPERLY SECURED TO THE MAIN FRAME. A SUDDEN CHANGE IN MOVEMENT OR DIRECTION CAN ALLOW THE UNSECURED WEIGHT TO FALL OFF THE FLOOR COVERING SCRAPER, RESULTING IN LOSS OF MACHINE CONTROL, PROPERTY DAMAGE AND/OR PERSONAL INJURY. THIS PROCEDURE IS ESPECIALLY IMPORTANT WHEN OPERATING THE FLOOR COVERING SCRAPER ON FLOORS AND/OR SURFACES ABOVE GROUND LEVEL.

3) Proper operator posture and stance will enhance productivity rates and minimize fatigue. Adjust the operator handle height to place the handle grips at approximately waist level. Keep the upper body as

ASSEMBLY INSTRUCTIONS/OPERATION

vertical as possible. This procedure will help to maximize leverage and minimize back related stress. Keep feet a comfortable distance apart to help provide stability and locomotion force. A proper operator position is depicted in FIGURE 25. Improper operator positions are depicted in FIGURES 26 and 27. The proper and improper operator positions depicted in this manual are not all inclusive.



FIGURE 25



FIGURE 26



FIGURE 27

4) The wide variety of potential covering materials along with the corresponding variety of jobsite environments, makes it impossible to develop a standardized operating procedure for the FLOOR COVERING SCRAPER. Use of the FLOOR COVERING SCRAPER will require constant trial and error testing until satisfactory results are achieved. Experience, gained over time, along with good common sense will help minimize the amount of necessary testing. Many factors will directly affect the operating parameters and/or techniques utilized for a specialized job application. Some of these factors include:

a) Work surface material yield and tensile values. As a general rule, these values will determine material removal rate per unit of time. Materials with high yield and tensile values will characteristically resist/limit penetration. For such materials, the accepted procedure is to decrease blade width and determine optimum blade angle relative to the floor surface. This will require increasing or decreasing the blade angle with the Back Saver™ Blade Control System. Other added benefits to this technique are decreased vibration, less operator fatigue and increased component service life.

b) Higher material removal rates can sometimes be achieved by making a series of passes 90 degrees to each other to form a waffle like pattern. This technique is especially useful when removing deeper accumulations of rubber type materials, material residues and dirt debris from industrial floors.

c) The covering removal process can be extremely abrasive to the blade cutting edge. Blades can be sharpened in the field by the use of the metal file stored on the fixed section of the operator handle. Use of the file in the field will not duplicate the original blade manufacturing process, but can significantly increase overall productivity rates versus the continued use of a dull blade. Remove the blade from the FLOOR COVERING SCRAPER per the procedures outlined in this manual. Clamp the blade in a suitable vice. Use the file to sharpen the blade with a procedure similar to that of sharpening a rotary lawnmower blade. FIGURE 28.



ASSEMBLY INSTRUCTIONS/OPERATION

PROPERTY DAMAGE AND/OR PERSONAL INJURY. FOR SUCH OPERATING CONDITIONS, ALWAYS WEAR A NIOSH/MSHA APPROVED DUST/MIST RESPIRATOR AND APPROPRIATE SAFETY RELATED APPAREL. CONSULT APPLICABLE OSHA REGULATIONS FOR SPECIFIC INFORMATION.

6) Dust and other particle contamination can be controlled by the use an appropriate industrial type vacuum system to remove/control dust and other particle contamination from the work surface.

FIGURE 28

! DANGER

EXERCISE EXTREME CAUTION WHEN SHARPENING THE BLADE. CLAMP THE BLADE FIRMLY IN THE VICE. REMAIN CLEAR OF THE CUTTING EDGE DURING THE SHARPENING PROCESS. IMPROPER CONTACT WITH THE BLADE CAN RESULT IN PROPERTY DAMAGE AND/OR PERSONAL INJURY.

5) The coverings removal process on many work surface materials can produce sparks, dust and other foreign particle contamination. Many covering materials, adhesives and/or mastics can contain asbestos and other chemicals that are known to cause physical harm and/or affect the environment. These types of materials need to be properly identified, contained and disposed of according to established OSHA, EPA and other rules and regulations.

! DANGER

SPARKS PRODUCED BY THE ACTIONS OF BLADE AND/OR CERAMIC TILE RIPPER ATTACHMENT AGAINST THE WORK SURFACE (FOR EXAMPLE: STRIKING ANCHOR BOLTS) CAN RESULT IN A FIRE AND/OR EXPLOSION. THIS OCCURRENCE CAN RESULT IN PROPERTY DAMAGE AND/OR PERSONAL INJURY.

! DANGER

THE CREATION OF DUST AND OTHER FOREIGN PARTICLE CONTAMINATION FROM THE COVERING REMOVAL PROCESS CAN RESULT IN

! DANGER

ALWAYS UTILIZE A VACUUM SYSTEM TO OPERATE WITHIN THE SPECIFIC JOBSITE REQUIREMENT. DUST MATERIAL CAN MEET CLASS II OR CLASS III SPECIFICATIONS OF THE NATIONAL ELECTRIC CODE® FOR HAZARDOUS LOCATION CLASSIFICATIONS. CONSIDERATION MUST ALSO BE GIVEN TO THE CREATION OF HAZARDOUS TYPE MATERIALS REQUIRING SPECIFIC DISPOSAL PROCEDURES. DETERMINE THAT THE VACUUM SYSTEM IS PROPERLY DESIGNED TO OPERATE WITHIN THESE ATMOSPHERES. CONSULT CURRENT NATIONAL ELECTRIC CODE®, OSHA AND ENVIRONMENTAL PROTECTION AGENCY REGULATIONS FOR SPECIFIC INFORMATION.

7) Water applied to the work surface is not normally utilized to control dust and other particle contamination. Water, and/or other conductive materials, should be removed from the work surface by an industry approved and/or accepted practice BEFORE utilizing the FLOOR COVERING SCRAPER to remove the covering material. The presence of water and/or any other conductive material on the work surface can substantially increase the potential electrocution concern for the operator and/or associated work personnel.

! DANGER

WATER OR OTHER CONDUCTIVE MATERIALS DEPOSITED ON THE WORK SURFACE INCREASES THE ELECTROCUTION POTENTIAL FOR THE OPERATOR AND/OR ASSOCIATED

ASSEMBLY INSTRUCTIONS/OPERATION

WORK PERSONNEL. DETERMINE THE FLOOR COVERING SCRAPER IS PROPERLY GROUNDED (NO FAULTS), THE EXTENSION CORD IS FREE OF CUTS, ABRASIONS, EXPOSED CABLE STRANDS AND THAT THE GFI PROPERLY FUNCTIONS TO ELIMINATE FAULT CONCERNS. IMPROPER MACHINE GROUNDING, EXTENSION CORDS AND/OR GFI CAN RESULT IN PROPERTY DAMAGE AND/OR PERSONAL INJURY.

8) Normal usage of the FLOOR COVERING SCRAPER will allow the build-up and accumulation of work surface materials on the surfaces. It is highly recommended that both the interior and exterior surfaces be properly cleaned after the completion of each use.

⚠ CAUTION

Failure to properly clean the interior surfaces of the FLOOR COVERING SCRAPER can result in dried material build-up and accumulation directly affecting bearing service life.

⚠ DANGER

EXERCISE EXTREME CAUTION WHEN UTILIZING ANY SOLVENT TO REMOVE ACCUMULATED MATERIALS FROM THE SURFACES OF THE MACHINE AND RELATED COMPONENTS. MANY SOLVENTS ARE FLAMMABLE. DO NOT SMOKE OR INTRODUCE FLAME IN THE WORK AREA. PROVIDE ADEQUATE VENTILATION AND WEAR PROPER SAFETY APPAREL.

⚠ DANGER

PROPERLY DISPOSE OF ALL ACCUMULATED MATERIALS PER OSHA AND ENVIRONMENTAL PROTECTION AGENCY CODES AND REGULATIONS. MANY ACCUMULATED MATERIALS CAN BE CLASSIFIED AS HAZARDOUS AND REQUIRE PROPER DISPOSAL PROCEDURES. CONTACT THE APPLICABLE GOVERNMENT AND/OR PRIVATE AGENCIES FOR SPECIFIC INFORMATION.

9) When the covering removal process creates a considerable amount of loose material on the work surface, it can become almost impossible to determine proper material removal depths and the extent of work already accomplished. The problem can be compounded if a vacuum system is not utilized. Loose

material should be removed by sweeping or other, appropriate processes and the FLOOR COVERING SCRAPER utilized until conditions again warrant removing the accumulated material.

STOPPING THE FLOOR COVERING SCRAPER ON THE JOBSITE.

1) Stopping the FLOOR COVERING SCRAPER is accomplished by moving the ON/OFF switch located on the operator handle to the OFF position. For safety considerations, it is also recommended that the extension cord be disconnected from both the FLOOR COVERING SCRAPER and electric power source whenever the FLOOR COVERING SCRAPER is not in use on the job site.

OPERATIONAL PARAMETERS AND TECHNIQUES FOR THE FLOOR COVERING SCRAPER.

1) The specific type and/or density of adhesives and mastics which bond coverings to the work surface can directly affect removal rates. Many adhesives or mastics remain flexible in the fully cured state. These types of materials are usually darker or black in color. The adhesives and mastics which become dried in the fully cured state are usually yellowish or opaque in color. These types of materials will usually require less effort to remove than the dark types which remain flexible even when cured.

2) As a general rule, the lower the adhesive or mastic density (amount) utilized to adhere the covering to the work surface, the lower the force required to "shear" through the bond and thus, the greater the covering removal rate.

3) As a general rule, the thicker the adhesive or mastic utilized to adhere the covering to the work surface, the greater the force required to "shear" through the bond and thus, the lower the covering removal rate.

4) The Back-Saver™ Blade Control System is designed to adjust blade angle relative to the work surface without first stopping the machine to adjust mechanical linkages or bend over to operate a crank lever system. The Back-Saver™ Control System features a crank lever located on the operator console. FIGURE 29. Crank the lever clockwise to decrease the blade angle. Turn the crank lever counterclockwise to increase the blade angle.



ASSEMBLY INSTRUCTIONS/OPERATION

FIGURE 29

5) Typically, adhesive/mastic densities or thickness change on the job site usually as a result of application rates on the work surface. This, in turn directly affects bond densities and thickness. As these factors change, the blade angle can be adjusted with the Back Saver™ Blade Control System to help optimize covering removal rates.

6) Keep the extension cord free and clear the the main frame area and orbiting blade/ceramic tile ripper attachment while the FLOOR COVERING SCRAPER is in operation. Contact with the blade can damage the extension cord and create a potential electrocution concern. In the event of damage, replace the extension cord with a factory approved replacement part only.

! DANGER

KEEP THE EXTENSION CORD FREE AND CLEAR OF THE MAIN FRAME AND BLADE AREA WHILE THE FLOOR COVERING SCRAPER IS IN OPERATION. CONTACT WITH THE MAIN FRAME AND BLADE AREA CAN RESULT IN PROPERTY DAMAGE AND/OR PERSONAL INJURY.

! DANGER

IN THE EVENT THE EXTENSION CORD BECOMES ENTANGLED ABOUT THE FLOOR COVERING SCRAPER AND/OR THE OPERATOR, TURN THE ELECTRIC MOTOR ON/OFF SWITCH TO THE OFF POSITION. FAILURE TO PROPERLY STOP THE FLOOR COVERING SCRAPER IN THIS OPERATING CONFIGURATION CAN RESULT IN PROPERTY DAMAGE AND/OR PERSONAL INJURY. DETERMINE THE EXTENSION CORD AND GFI ARE IN PROPER CONDITION TO CONTINUE OPERATION. REPLACE ANY DAMAGED

COMPONENT WITH A FACTORY APPROVED REPLACEMENT PART ONLY.

! DANGER

DISCONNECT THE EXTENSION CORD FROM THE FLOOR COVERING SCRAPER WHEN TRAVERSING UP AND DOWN STAIRWAYS. AN IMPROPERLY STORED/CONNECTED EXTENSION CORD CAN ENTRAP AND/OR ENTANGLE PERSONNEL, RESULTING IN PROPERTY DAMAGE AND/OR PERSONAL INJURY.

7) Scoring blades are available to remove covering material such as rubber-backed carpet and linoleum from concrete and wood surfaces. The vertical ends of the scoring blade are designed to shear the covering and remove it in various widths as determined by the overall blade width. FIGURE 30.



FIGURE 30

! CAUTION

Do not operate the FLOOR COVERING SCRAPER with the vertical ends of the scoring blade facing down toward the work surface. In this configuration, damage to the work surface can result.

ASSEMBLY INSTRUCTIONS/OPERATION

8) Part Number SFCS16-1900 Blade can be mounted to the FLOOR COVERING SCRAPER in the offset configuration to allow coverings to be removed from under the kick panel areas of cabinets and other, unaccessible locations. A stiffener is included with this blade as a standard accessory and must be mounted whenever this blade is utilized to minimize blade deflection. FIGURE 31.



FIGURE 31

⚠ CAUTION

Do not operate Part Number SFCS16-1900 Blade without the additional stiffener properly mounted to the blade. Improper use of this blade without the additional stiffener can result in property damage and/or personal injury.

Service

PREVENTATIVE MAINTENANCE CHECK LIST.

The normal operation of the FLOOR COVERING SCRAPER produces extreme dirt and dust, along with levels of random vibration. Before operating the FLOOR COVERING SCRAPER, the following service list should be accomplished. This list is for reference only and is not intended to be all inclusive. Other topic areas can be added at the discretion of the owner(s) and/or operator(s):

⚠ DANGER

DISCONNECT THE FLOOR COVERING SCRAPER FROM THE EXTENSION CORD AND/OR POWER SOURCE RECEPTACLE BEFORE PERFORMING ANY SERVICE WORK OR REPAIR. TURN THE ON/OFF SWITCH TO THE OFF POSITION. FAILURE TO PROPERLY DISCONNECT THE FLOOR COVERING SCRAPER FROM THE POWER SOURCE DURING THESE ACTIVITIES CAN RESULT IN PROPERTY DAMAGE AND/OR PERSONAL INJURY.

1) Check all fasteners for proper torque values. If a fastener requires retorquing, consult a torque chart for the proper value. Properly discard and replace any worn fastener with a factory approved, replacement part.

2) Check the rubber elastomeric mounts for damage and/or wear. Replace as necessary.

3) Check the external support bearing mounted to the motor shaft for wear and proper alignment. Many loose covering materials that accumulate in and around the support bearing area can be extremely abrasive. These materials can breach the bearing seals and significantly reduce load capacity and service life.

4) Determine the interior sections of the frame are free of material build-up. Such build-ups can restrict the operating process and present a potential safety hazard. Clean and remove any material build-up from the FLOOR COVERING SCRAPER after each use.

5) Keep loose materials from accumulating around the motor cooling fan. Remove the fan shroud and clean as necessary.

6) Remove material accumulations from the exterior surfaces of the electric motor. The electric motor is a totally enclosed, fan cooled (TEFC) design. Keep the fan fins clear of material accumulations to enhance air flow over the motor exterior for cooling purposes.

⚠ CAUTION

Observe all applicable safety precautions for the solvent.

7) Lubricate the caster wheel bearings with a dry film lubricant. Use of other lubricant types can attract foreign materials and reduce bearing service life.

ASSEMBLY INSTRUCTIONS/OPERATION

8) Zerk® type grease fittings are provided in two separate locations:

- a) To lubricate the Back Saver™ Blade Control System jackscrew.
- b) To lubricate the exciter bearing housing casting. The exciter unit utilizes a sealed type ball bearing. The Zerk® fitting provides lubrication for the self-aligning feature of the bearing unit. Consult the LUBRICATION section for additional information.

Sleeve type bearings are self-lubricating and will not normally require additional lubrication during their normal service life. Ball type bearings are shielded or sealed and will not normally require additional lubrication during their normal service life.

9) Determine that all safety decals and operational information decals (including the applicable Quik Tips information) is in proper and readable condition. Replace any missing or damaged safety decal and/or information decal with a factory approved replacement part only.

10) The FLOOR COVERING SCRAPER utilizes antivibration handle grips on the operator handle to enhance control and help dampen the forces experienced during the covering removal process. Determine the handle is equipped with properly fitting handle grips of sufficient integrity to allow for proper job function as outlined in this manual. Loose fitting handle grips or grips without end caps should be replaced with factory approved replacement parts only.

! DANGER

DO NOT OPERATE THE FLOOR COVERING SCRAPER WITHOUT PROPERLY FITTED HANDLE GRIPS OF SUFFICIENT INTEGRITY INSTALLED ON THE OPERATOR HANDLE. OPERATING THE FLOOR COVERING SCRAPER WITH IMPROPER OR NO HANDLE GRIPS CAN RESULT IN PROPERTY DAMAGE AND/OR PERSONAL INJURY.

LUBRICATION REQUIREMENTS.

Parts Required:

1 each, standard grease gun filled with one of the following: ESSO Beacon 325, Shell Alvania #2, Chevron SRI, or equivalent.

1 each, container of dry film lubricant.

- 1) Lubricate the caster wheel bearings with a dry film lubricant only. Dry film lubricants dry immediately upon contact. Use sparingly. Excess lubricant will attract the fine grained, powdered materials described and directly affect bearing service life.

! CAUTION

Do not lubricate the caster wheels with any lubricant other than a dry film type. Grease and many other liquid type lubricants will attract foreign material accumulations that can reduce bearing service life.

2) Zerk™ type grease fittings are provided at two locations:

- a) To lubricate the Back Saver™ Blade Control System jackscrew. Keep the jackscrew properly lubricated to minimize friction when operating the blade control lever. Excessive lubrication will attract foreign material accumulations that can reduce jackscrew service life.

FIGURE 32.

- b) To lubricate the exciter bearing housing casting. The exciter utilizes a sealed type ball bearing. The Zerk® fitting provides lubrication for the self-aligning feature of the bearing unit. FIGURE 33. Grease interval will vary depending upon machine utilization rates and operating environment factors.

Sleeve type bearings utilized for the operator handle are self-lubricating and will not normally require additional lubrication during their normal service life. Ball type bearings are shielded or sealed and will not normally require additional lubrication during their normal service life.



FIGURE 32



FIGURE 33

ELECTRIC MOTOR SERVICE.

The electric motor is capable of operating for many years with a reasonably small amount of maintenance. Before attempting to service the motor, disconnect the FLOOR COVERING SCRAPER from the power supply. Clean the motor surfaces periodically, preferably with a vacuum cleaner. Heavy accumulations of dirt and lint will result in overheating and premature failure of the motor.

The electric motor is equipped with higher capacity ball bearings and under normal service and ambient temperatures, should not require relubrication for many years. If you feel that the motor requires relubrication, contact the local representative of the motor manufacturer for specific information.

The seals utilized with the motor are intended to deliver a longer service life in a dust filled atmosphere. When replacing the seals, utilize only components meeting the original factory specifications.

Troubleshooting

ELECTRIC MOTOR.

MOTOR FAILS TO START

ON/OFF switch in the OFF position. Place switch in the ON position.

Thermal protection switch activated. Allow time for motor to cool. Motor will not start until the temperature is reduced low enough for the red switch located near the capacitor to be activated.

GFI switch activated. Push GFI button to test and rearm. Reconnect to power source.

Improper extension cord connection. Determine all connections produce a closed circuit.

No power being received from power source. Check power source for correct voltage and amperage requirements.

MOTOR LOSES POWER

Check power source for correct voltage and amperage requirements.

High operating temperatures. Clean fan blades and exterior surfaces.

OPERATIONAL PROBLEMS.

UNEVEN BLADE WEAR

Incorrect blade installation. See **INSTALLING A BLADE OR CERAMIC TILE RIPPER ATTACHMENT IN THE FLOOR COVERING SCRAPER.**

Damaged exciter plate. Replace plate.
Damaged elastomeric rubber mount(s). Replace mount(s).

Bent blade. Replace blade.

EXCESSIVE JUMPING ON THE WORK SURFACE

Incorrect blade or ceramic tile ripper attachment installation. See **INSTALLING A BLADE OR CERAMIC TILE RIPPER ATTACHMENT IN THE FLOOR COVERING SCRAPER.**

Damaged exciter plate. Replace plate.

Damaged elastomeric rubber mount(s). Replace mount(s).

Improper blade angle. Readjust blade angle.

ACCELERATED EXCITER SHAFT BEARING WEAR AND/OR FAILURE

Misaligned and/or improperly tensioned bearing housing/mounting surfaces. Replace bearing and realign bearing housing/mounting surface.

Bent electric motor shaft. Replace motor.

Improper lubrication. See **LUBRICATION REQUIREMENTS.**

DIFFICULTY IN OPERATING THE BACK SAVER™ BLADE CONTROL SYSTEM

Misaligned jackscrew bearing. Loosen and realign.

Improper lubrication. See **LUBRICATION REQUIREMENTS.**

Bent jackscrew. Replace jackscrew and flexible joint assembly.

UNEVEN COVERING MATERIAL REMOVAL

Excessive material build-up on caster wheel face surface. Remove material. Readjust wheel scraper to wheel gap setting: .03/.06 inch (.8/1.5 mm).

Excessive caster wheel bearing wear. Replace caster wheel and shoulder type capscrew.

Excessive axle shoulder type capscrew wear. Replace capscrew. Check caster wheel bearing for wear. Replace as necessary.

Damaged elastomeric rubber mount(s). Replace mount(s).

Damaged exciter plate. Replace plate.

Bent blade. Replace blade

Storage

Proper procedure for long term storage of the FLOOR COVERING SCRAPER will protect it against the effects of corrosion and damage. If the FLOOR COVERING SCRAPER is not to be operated for a period of 30 days or more, proceed to store as follows:

- 1) Never store the FLOOR COVERING SCRAPER with the blade or ceramic tile ripper attachment installed. Remove the blade or ceramic tile ripper attachment from the FLOOR COVERING SCRAPER per the procedures outlined in this manual.

CAUTION

Do not store the FLOOR COVERING SCRAPER with the blade or ceramic tile ripper attachment attached. This configuration can result in property damage and/or personal injury.

- 2) Clean all accumulated foreign material from the FLOOR COVERING SCRAPER utilizing an appropriate safety solvent.

CAUTION

Observe all applicable safety precautions for the solvent.

- 3) Check all visible parts for wear, breakage or damage. Order any part required to make the necessary repair. This will avoid a needless delay when operating the FLOOR COVERING SCRAPER at next use.
- 4) Apply a dry film lubricant to all exposed metal components to prevent rust.
- 5) Block the bottom of the main frame to prevent machine weight against the exciter plate. This procedure will reduce impact loads to the elastomeric rubber mounts, minimize deflection and increase service life.
- 6) Store the FLOOR COVERING SCRAPER inside. If the FLOOR COVERING SCRAPER must be stored outside, protect it with a suitable covering.

Specifications

FRAME

STRUCTURE	Unitized, welded steel plate.
DRIVE SYSTEM	Random orbit, direct shaft mount.
NUMBER OF ELASTOMERIC RUBBER MOUNTS	4.
WIDTH	14-1/2 inches (368 mm).
WIDTH (AT OPERATOR HANDLE)	23 inches (584 mm).
LENGTH (HANDLE FOLDED)	24 inches (610 mm).
LENGTH (OPERATING CONFIGURATION)	34 inches (864 mm).
HEIGHT (HANDLE FOLDED)	23 inches (584 mm).
HEIGHT (MAXIMUM HANDLE EXTENSION)	42 inches (1067 mm).

GENERAL

WEIGHT (WITH EXTERNAL WEIGHT LESS BLADE)	130 lbs (59 kg).
EXTERNAL WEIGHT, EACH	14 lbs (6 kg).

ELECTRIC MOTOR 3/4 hp, 1725 RPM, 10.3 full loaded amperes @ 115 VAC, 60 Hz, thermally protected. The electric motor requires a clean (no other electric products on the same circuit) 15 ampere capacity circuit to properly function. The motor can be wired to also operate from a 230 VAC, 60 Hz, power source. Contact the Customer Service Department for specific information.

NUMBER OF BLADE OSCILLATIONS	1725 PER MINUTE
------------------------------	-----------------

ADJUSTABLE AXLE ASSY.

ADJUSTABLE AXLE ASSY.

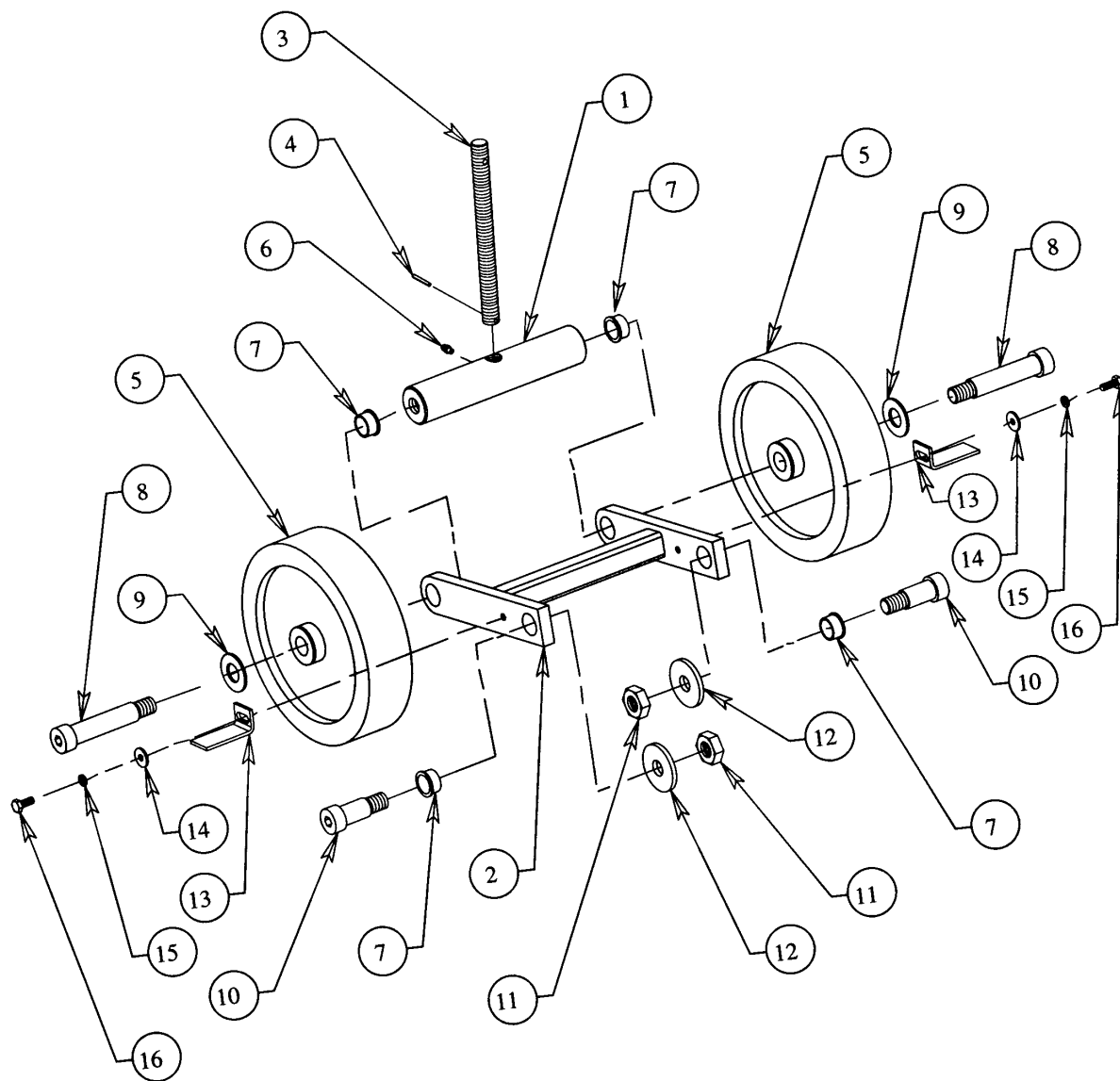

ADJUSTABLE AXLE ASSY.

ADJUSTABLE AXLE ASSY.

<u>NO.</u>	<u>PART NO.</u>	<u>PART NAME</u>	<u>QTY.</u>	<u>REMARKS</u>
1	SFCS160060	AXLE	1	
2	SFCS160130	AXLE ARM ASSY.	1	
3	SFCS160050	SCREW, JACK	1	
4	21020800	PIN ROLL, SPRIAL 1/8"X1"	1	
5	SFCS160060	WHEEL 8"	2	
6	5500590	FITTING GREASE	1	
7	6600410	BUSHIG, BRONZE 3/4" ID	4	
8	62122400	BOLT, SHOULDER 3/4"X3"	2	
9	200682	WASHER, FIBER	2	
10	62121200	BOLT, SHOULDER 3/4"X1-1/2"	2	
11	18100000	NUT, HEX 5/8-11 UNC, PLATED	2	
12	17100000	WASHER, FLAT 5/8" PLATED	2	
13	SFCS160090	SCRAPER, WHEEL	2	
14	17050000	WASHER, FLAT 5/16" PLATED	2	
15	16060000	WASHER, LOCK 5/16" PLATED	2	
16	5505060700	SCREW, BUTTON HEAD 5/16" UNCX3/4" PLATED	2	

REPLACEMENT CUTTING BLADES ASSY.

REPLACEMENT CUTTING BLADES ASSY.

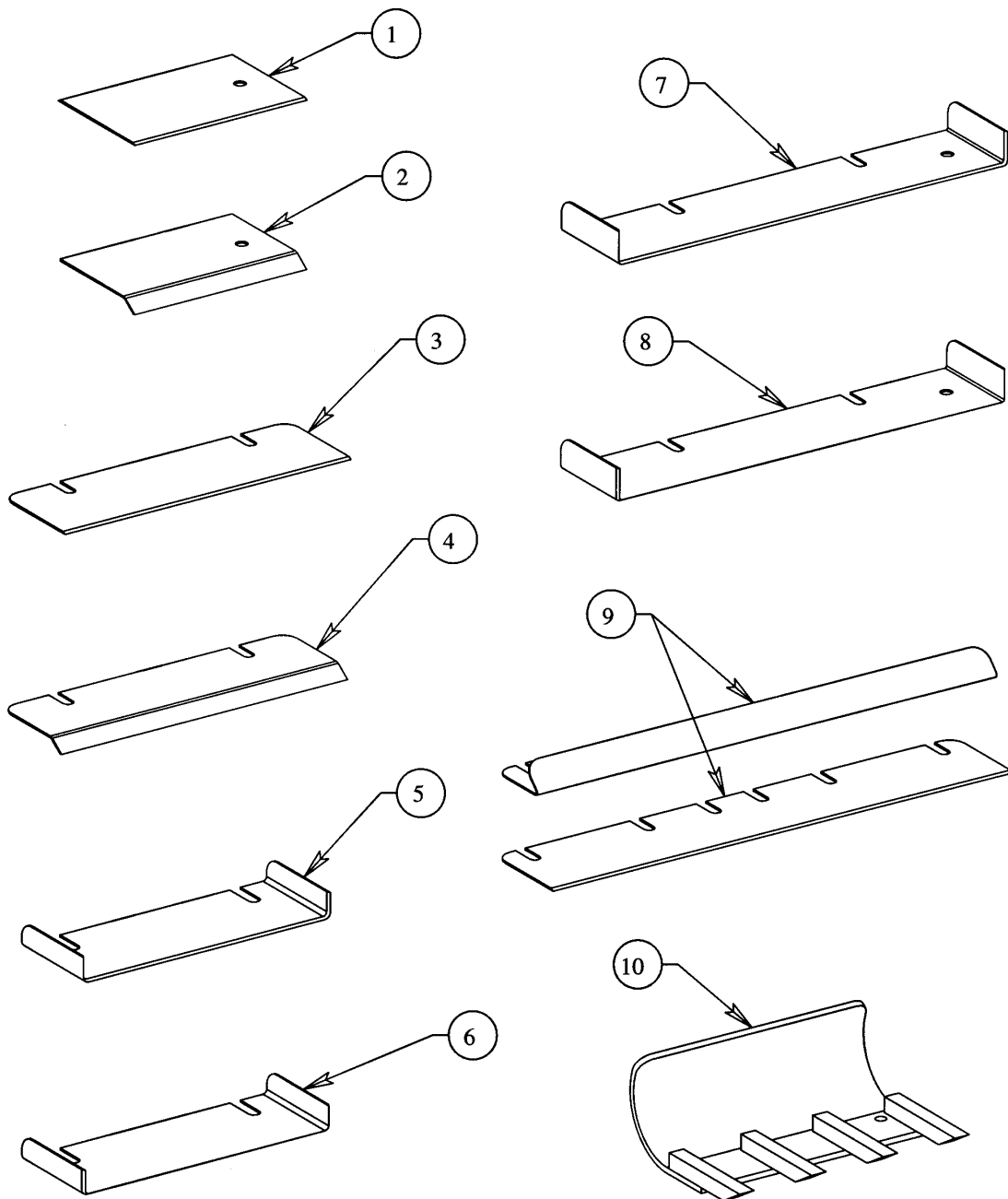

REPLACEMENT CUTTING BLADES ASSY.

REPLACEMENT CUTTING BLADES ASSY.

<u>NO.</u>	<u>PART NO.</u>	<u>PART NAME</u>	<u>QTY.</u>	<u>REMARKS</u>
1	SFCS161100	BLADE, STRAIGHT 4"X6" GENERAL PURPOSE REMOVAL PROJECTS ON BOTH CONCRETE & WOOD SURFACES	1	
2	SFCS161200	BLADE, ANGLED 6" WIDE MASTIC & THIN FILM COVERINGS REMOVAL ON ONCRETE SURFACES <i>ONLY.</i>	1	
3	SFCS161300	BLADE, STRAIGHT 3"X10 GENERAL PURPOSE REMOVAL PROJECTS ON BOTH CONCRETE & WOOD SURFACES	1	
4	SFCS161400	BLADE, ANGLED 10" WIDE MASTIC & THIN FILM COVERINGS REMOVAL ON CONCRETE SURFACES <i>ONLY.</i>	1	
5	SFCS161500	BLADE, SCORING 8" WIDE GLUED CARPETS & SHEET TYPE LINOELUM RUBBER PVC, ETC. PRODUCTS FROM CONCRETE SURFACES <i>ONLY.</i>	1	
6	SFCS161600	BLADE, SCORING 8" WIDE GLUED CARPETS & SHEET TYPE LINOELUM RUBBER PVC, ETC. PRODUCTS FROM CONCRETE SURFACES <i>ONLY.</i>	1	
7	SFCS161700	BLADE, SCORING 13" WIDE GLUED CARPETS & SHEET TYPE LINOELUM RUBBERPVC, ETC. PRODUCTS FROM CONCRETE SURFACES <i>ONLY.</i>	1	
8	SFCS161800	BLADE, SCORING 13" WIDE GLUED CARPETS & SHEET TYPE LINOELUM RUBBER PVC, ETC. PRODUCTS FROM CONCRETE SURFACES <i>ONLY.</i>	1	
9	SFCS161900	BLADE, STRAIGHT 4"X6" GENERAL PURPOSE REMOVAL PROJECTS ON BOTH CONCRETE & WOOD SURFACES.	1	
10	SFCS162000	RIPPER ATTACHEMENTUSE FOR REMOVEING CERAMIC TILE, HARDWOOD FLOOR MATERIALS, THICK TILES, & SIMILAR TYPE FLOORING MATERIALS	1	

FRAME ASSY.

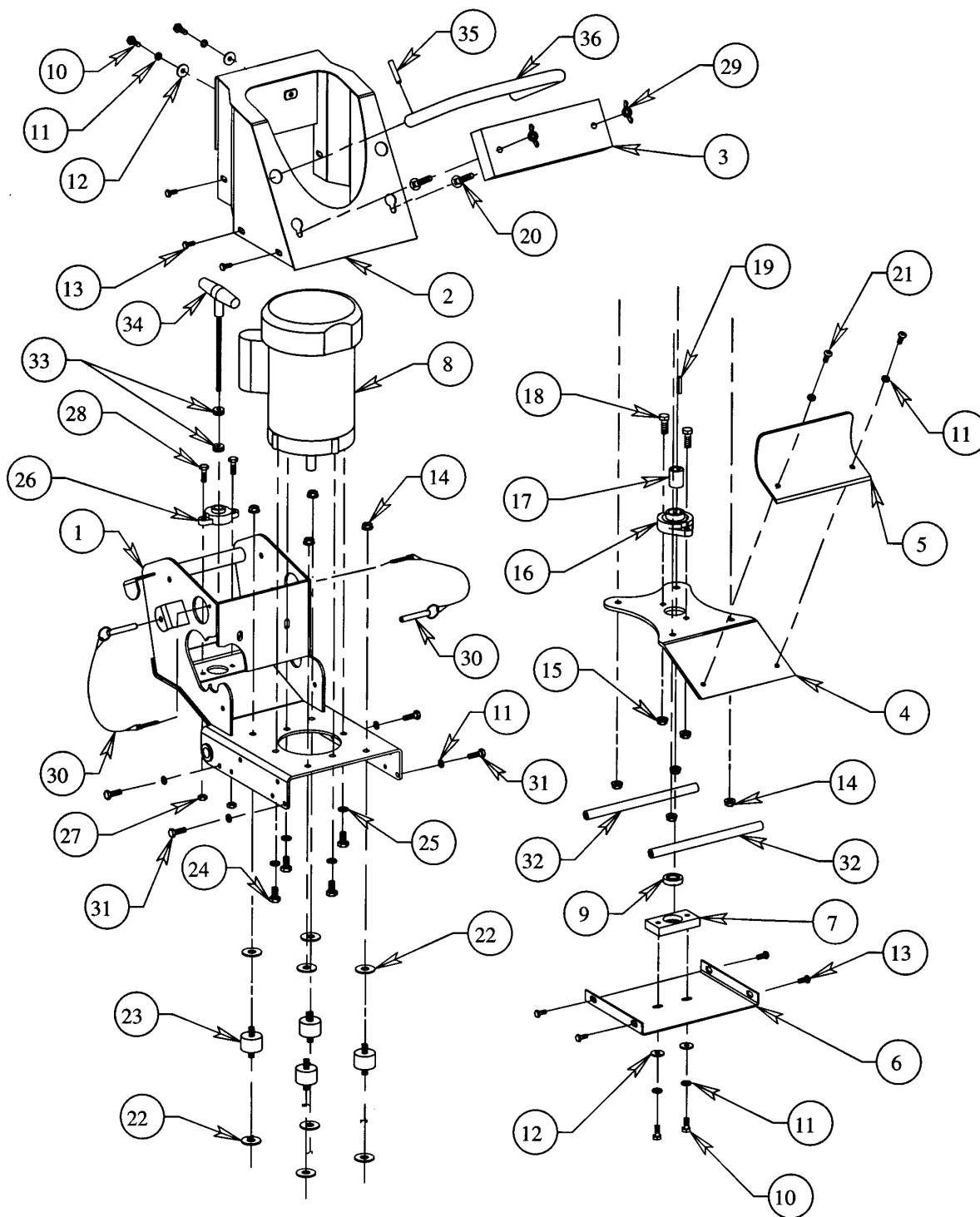

FRAME ASSY.

<u>NO.</u>	<u>PART NO.</u>	<u>PART NAME</u>	<u>QTY.</u>	<u>REMARKS</u>
1	SFCS160010	FRAME	1	
2	SFCS160170	COVER, MOTOR	1	
3	SFCS160230	BLOCK, WEIGHT	1	
4	SFCS160020	PLATE, ORBITAL	1	
5	SFCS160190	PLATE, CLAMPING	1	
6	SFCS160110	COVER, BOTTOM	1	
7	SFCS160100	BLOCK, BEARING	1	
8	SFCS160030	MOTOR ELECTRIC 3/4HP 115 VOLT	1	
9	SFCS160330	BEARING, SUPPORT	1	
10	15050700	SCREW, CAP 5/16-18 UNC X 7/8" PLATED	4	
11	16050000	WASHER, LOCK 5/16, PLATED	10	
12	17050000	WASHER, FLAT 5/16, PLATED	4	
13	48050800	SCREW, CAP SELF TAP 5/16-18 UNC X 3/4" PLATED	10	
14	86060000	NUT, HEXAGON, FLANGE 3/8-16 UNC, PLATED	8	
15	18060000	NUT, HEXAGON, 3/8-16 UNC, PLATED	2	
16	SFCS160320	BEARING, 2 BOLT FLANGED	1	
17	SFCS160070	HUB, OFFSET	1	
18	15060800	SCREW, CAP 3/8-16 UNC X 1" PLATED	2	
19	63031000	KEY, SQUARE 3/16" X 1-1/4"	1	
20	87061800	BOLT, CARRIAGE 3/8-16 UNC X 2-1/4" PLATED	2	
21	55050600	SCREW, BUTTON HEAD 5/16-18 UNC X 3/4" PLATED	2	
22	49060000	WASHER, FENDER 3/8" X 1-1/2"	8	
23	SFCS160310	MOUNT, RUBBER	4	
24	15060800	SCREW, CAP 3/8-16 UNC X 1", PLATED	4	
25	16060000	WASHER, LOCK 3/8", PLATED	4	
26	SP80430	BEARING, FLANGE	1	
27	53050000	NUT, HEX., NYLOCK 5/16-18 UNC, PLATED	2	
28	15050800	SCREW, CAP 5/16-18 UNC X 3/4", PLATED	2	
29	43060000	NUT, WING 3/8-16 UNC, PLATED	2	
30	SFCS160210	PIN/LANYARD ASSY.	2	
31	15050600	SCREW, CAP 5/16-18 UNC X 3/4", PLATED	4	
32	SFCS160220	BAR, STOP	2	
33	SFCS160300	GROMMET	2	
34	SFCS160260	T-HANDLE HEX KEY 3/16"	1	
35	20031000	PIN, ROLL 3/16 X 1-1/4"	2	
36	SFCS160200	TUBE, HANDLE	1	

OPERATOR HANDLE ASSY.

OPERATOR HANDLE ASSY.

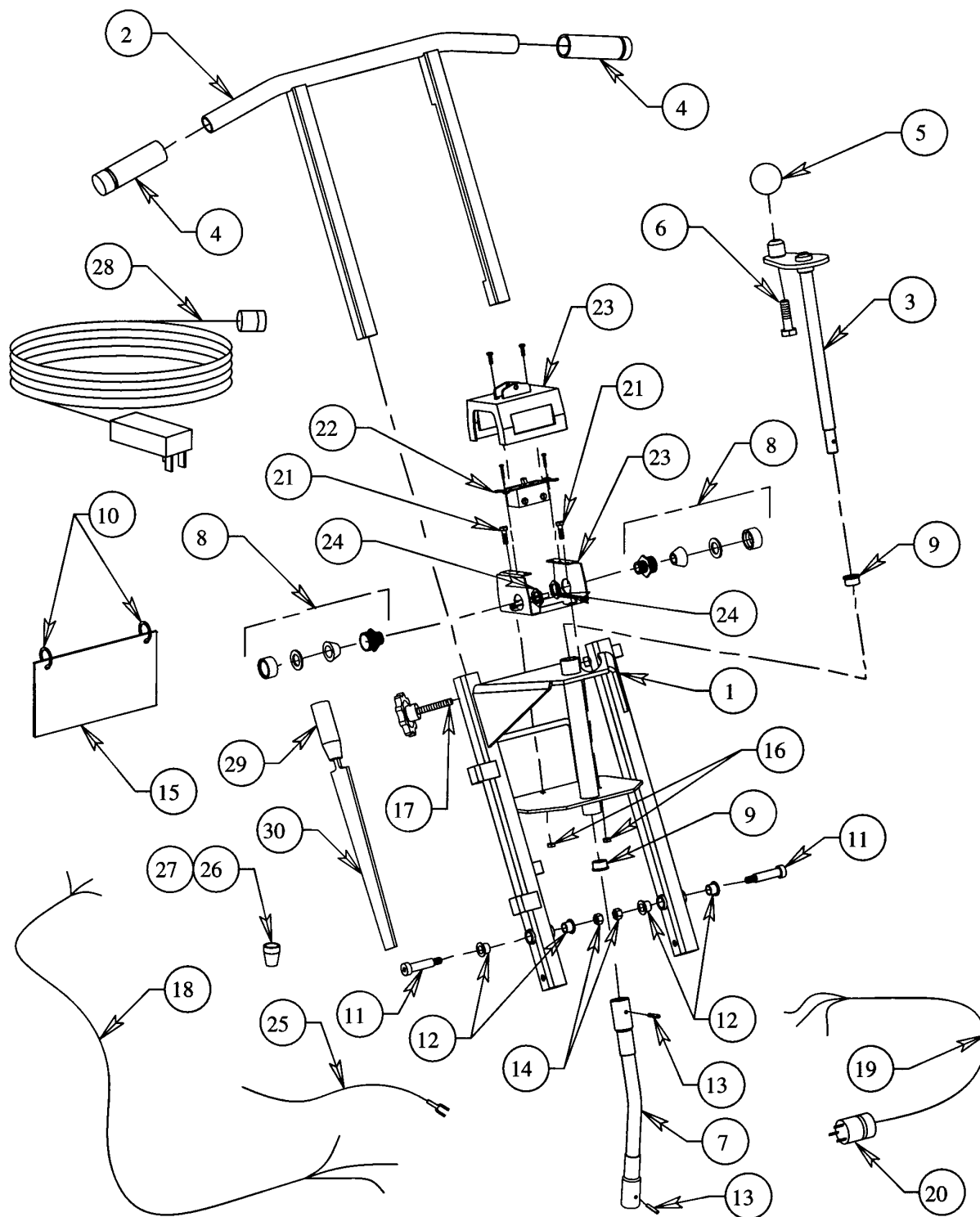

OPERATOR HANDLE ASSY.

OPERATOR HANDLE ASSY.

<u>NO.</u>	<u>PART NO.</u>	<u>PART NAME</u>	<u>QTY.</u>	<u>REMARKS</u>
1	SFCS160180	HANDLE, LOWER	1	
2	SFCS160160	HANDLE, TOP	1	
3	SFCS160140	CRANK ASSY.	1	
4	SFCS160290	GRIP, RUBBER	2	
5	SP80120	KNOB	1	
6	15081600	SCREW, CAP 1/2-13 UNC X2", PLATED	1	
7	SFCS160120	HOSE, U-JOINT	1	
8	CG3150	BUSHING, STRAIN RELIEF	2	
9	6600410	BUSHING, BRONZE 3/4" ID	2	
10	KIC172	RING, KICK-OUT	2	
11	62081400	BOLT, SHOULDER 1/2" X 1-3/4"	2	
12	SFCS160340	BUSHING, BRONZE 1/2" ID	2	
13	20030900	PIN, ROLL 3/16" X 1-1/8"	2	
14	86060000	NUT, HEXAGON, FLANGE 3/8-16 UNC, PLATED	2	
15	SFCS160280	SIGN, TIPS	1	
16	53030000	NUT, HEXAGON, NYLOCK #10-24 UNC, PLATED	2	
17	SFCS160150	KNOB ASSY.	2.	
18	SFCS160080	CABLE, SWITCH/MOTOR	1	
19	SFCS160040	CABLE, PLUG/SWITCH	1	
20	HUB4720C	PLUG, TWIST LOCK, MALE 15A	1	
21	60030500	SCREW, SOCKET HEAD #10-24 UNC, PLATED	2	
22	HUB1222	SWITCH ASSY.	1	
23	HUB1390	HOUSING SWITCH	1	
24	801	NUT, BULKHEAD	2	
25	SFCS160350	WIRE, PIGTAIL GROUND	2	
26	WIRE NUT R	WIRE NUT RED	1	
27	WIRE NUT Y	WIRE NUT YELLOW	2	
28	SFCS161000	CORD, EXT. W/INTERGRAL GFI SWITCH	1	
29	SFCS160270	FILE, MILL BASTARD 10"	1	
30	SFCS160250	FILE, HANDLE, LONG FEMULE	1	

DECALS

1
STOW

STOW

⚠ WARNING

KEEP CLEAR OF ROTATING PARTS

⚠ WARNING

ALWAYS OPERATE THIS MACHINE WITH A GROUND FAULT CIRCUIT INTERRUPTER UTILIZED. IMPROPER USAGE CAN RESULT IN AN ELECTRICAL SHOCK AND/OR ELECTROCUTION. CONSULT OPERATORS MANUAL FOR SPECIFIC INFORMATION.

⚠ WARNING

KEEP GUARDS IN PLACE

⚠ WARNING

BEFORE HOISTING THIS MACHINE CONSULT THE APPLICABLE OPERATOR MANUAL. IMPROPER HOISTING PROCEDURES CAN RESULT IN PROPERTY DAMAGE AND/OR PERSONAL INJURY.

CUSTOMER SERVICE INFORMATION

Avoid injury, use the product properly. Do not drink or use alcohol. Do not operate machinery if you are impaired. For technical or application assistance for the product, first contact your dealer. If the product user manual, contact the location from which it was purchased. For further assistance, please contact the General Equipment Company Customer Service Department. Telephone: 1-800-551-8824 or +1-507-451-5500. Fax: 1-877-284-6797 or +1-507-451-5511. Email: general@general-equip.com. This is no charge. © 2006 General Equipment Company. Model #1072

⚠ WARNING

CONTACT WITH BLADE EDGE CAN CAUSE PERSONAL INJURY

⚠ WARNING

TO AVOID PROPERTY DAMAGE OR PERSONAL INJURY REMOVE BLADE OR ATTACHMENT BEFORE LIFTING OR TRANSPORTING MACHINE

⚠ WARNING

EYE, EAR, AND RESPIRATION PROTECTION REQUIRED

DECALS

<u>NO.</u>	<u>PART NO.</u>	<u>PART NAME</u>	<u>QTY.</u>	<u>REMARKS</u>
1	DCLSDP	DECAL: "STOW LARGE"	1	
2	SP85030	DECAL: WARNING	1	
3	510165	DECAL: "STOW SMALL"	1	
4	SFCS165020	DECAL: WARNING	1	
5	SFCS165030	DECAL: WARNING	1	
6	SP85040	DECAL: WARNING	1	
7	SP85050	DECAL: WARNING	1	
8	SFCS165010	DECAL: ANGLE ADJUSTMENT	1	
10	CS85050	DECAL: WARNING	1	
11	SFCS165040	DECAL: WARNING	1	
12	SG245072	DECAL: ASSISTANCE	1	



PAYMENT TERMS

Terms of payment for unit sales are 2% 15 days net 30 days from date of invoice unless otherwise specifically stated on our invoice. Parts invoices have terms of net 10 days.

Minimum parts billing is \$15.00 net.

Applicable discounts will be computed on merchandise value only. Late charges will be assessed at prevailing rates. Cash discounts cannot be taken on current billings if any previously billed amounts are past due.

FREIGHT POLICY

Freight policy is established to offer customers every advantage possible. Due to bulk freight ratings on some equipment and other shipping considerations, freight policies differ by equipment type. Actual back freight may be charged for shipments originating from other than specified FOB warehouses. **See Freight Policy for details.**

All STOW domestic sales are FOB nearest available designated MQ/STOW warehouse. Export orders are ex-works factory located in Carson, CA or Boise, ID.

Additions to orders already shipped cannot be accepted for freight minimums.

Should STOW elect to make partial shipments of an order originally complying with the "freight allowed" requirements, transportation charges will be absorbed by STOW on any subsequent shipment applying to that order.

All other orders will be shipped collect or prepaid with charges added to the invoice. STOW's responsibility ceases when a signed manifest has been obtained from the carrier, and any claim for shortage or damage must be settled between the consignee and the carrier.

Parts: FOB Carson, California or Boise, Idaho. **See Freight Policy for details and additional discounts.**

DROP SHIPMENTS

STOW reserves the right to refuse Drop Shipments outside the normal service area of the purchasing dealer.

FIELD WAREHOUSES

Field Warehouses are currently located in California, Georgia, Idaho, Iowa, and New Jersey

SPECIAL EXPEDITING SERVICE

The higher of a \$35.00 surcharge or actual costs will be added to the invoice for special handling, including bus shipments, or in cases where STOW personnel must personally deliver the equipment or parts to the carrier.

RETURNED GOODS POLICY

Return shipments may be accepted and credit allowed, subject to the following provisions.

1. A Returned Material Authorization (RMA) must be approved by STOW prior to shipment. Approvals for returned goods must be with just cause and are at the sole discretion of STOW. A copy of the Authorization must accompany the shipment to the designated Warehouse.
2. Parts being returned must be listed as currently supplied on the current parts list.
3. Parts must be in new and resalable condition in the original package, with part numbers clearly marked.
4. Units and accessories must be current models in the latest price list and in new and resalable condition.
5. Special order items are not returnable for credit.
6. Credit on returned parts and units will be issued at actual dealer net price at time of purchase less 15% restocking charge.
7. All returned shipments are to be made to the STOW designated receiving point, freight prepaid at the sender's expense.



Atlanta • Boise • Newark • Quebec, Canada
Manchester, UK • Rio de Janeiro, BR • Puebla, MX

The sender will be notified of any material received that does not meet the above provisions. Such material will be held for 30 days from notification pending instructions. If a reply is not received within 30 days, the material will be returned to the sender at his expense with no credit issued.

PRICING, REBATES AND SPECIFICATIONS

Every effort will be made to provide adequate notice of changes; however, prices and equipment specifications are subject to change without notice.

Price changes are effective on a specific date and all orders received on or after that date will be billed at the revised price.

Rebates for price reductions and added charges for price increases will not be made for stock in dealer inventory at the time of a price change.

STOW reserves the right to quote and sell direct to Government agencies and to Original Equipment Manufacturer accounts who use our products as integral parts of their own products.

LIMITATION OF SELLER'S LIABILITY

STOW shall not be liable hereunder for damages in excess of the purchase price of the item with respect to which damages are claimed and in no event shall STOW be liable for loss of profit or good will or for any other special, consequential or incidental damages.

LIMITATION OF WARRANTIES

There are no warranties, express or implied, made by STOW hereunder on Products manufactured or distributed by it except the warranty against defects in material and workmanship on new Products to the original purchaser, as set forth in the STOW New Product Limited Warranty.

STOW CONSTRUCTION EQUIPMENT

POST OFFICE BOX 6254
CARSON, CALIFORNIA 90749
310-661-4242 • 877-BUY-STOW
FAX: 310-604-9237
E-MAIL: stow@stowmfg.com
www.stowmfg.com



A large, empty rectangular box with a thin black border, occupying the central portion of the page. It is intended for handwritten notes.

OPERATION AND PARTS MANUAL

HERE'S HOW TO GET HELP

PLEASE HAVE THE MODEL AND SERIAL NUMBER ON-HAND WHEN CALLING

PARTS DEPARTMENT

800-427-1244 or 310-537-3700

FAX: 800-672-7877 or 310-637-3284

SERVICE DEPARTMENT

800-421-1244

FAX: 310-537-4259

TECHNICAL ASSISTANCE

800-478-1244

FAX: 310-631-5032

WARRANTY DEPARTMENT

888-661-4279, or 310-661-4279

FAX: 310-537-1173



STOW CONSTRUCTION EQUIPMENT
A DIVISION OF MULTIQUIP INC.
POST OFFICE BOX 6254
CARSON, CA 90749
310-537-3700 • 888-252-STOW [888-252-7869]
FAX: 310-537-1986 • FAX: 800-556-1986
E-MAIL: stow@multiquip.com • WWW:
stowmfg.com

PARTS DEPARTMENT:

800-427-1244
FAX: 800-672-7877

SERVICE DEPARTMENT/TECHNICAL ASSISTANCE:

800-478-1244
FAX: 310-631-5032