



TEREX®

Service Manual

RL4000D2

First Edition
First Printing
Part No. 116473
September 2008

Discount-Equipment.com

Discount Equipment

Discount-Equipment.com is your online resource for commercial and industrial quality parts and equipment sales.

Locations:

Florida (West Palm Beach): [561-964-4949](tel:561-964-4949)

Outside Florida TOLL FREE: [877-690-3101](tel:877-690-3101)

Need parts? Check out our website at www.discount-equipment.com

Can't find what you need?

Click on this link: <http://www.discount-equipment.com/category/5443-parts/> and fill out the request form.

Please have the machine model and serial number available in order to help us get you the correct parts. One of our experienced staff members will get back to you with a quote for the right part that your machine needs.

We sell worldwide for the brands: Genie, Terex, JLG, MultiQuip, Mayco, Toro/Stone, Diamond Products, Magnum, Airman, Mustang, Power Blanket, Nifty Lift, Atlas Copco, Chicago Pneumatic, Allmand Brothers, Essick, Miller Spreader, Skyjack, Lull, Skytrak, Tsurumi, Husquvarna/Target, Whiteman-Concrete/Mortar, Stow-Concrete/Mortar, Baldor, Wacker, Sakai, Snorkel, Upright, Mi-T-M, Sullair, Neal, Basic, Dynapac, MBW, Weber, Bartell, Bennar Newman, Haulotte, Ditch Runner, Blaw-Knox, Himoina, Best, Buddy, Crown, Edco, Wyco, Bomag, Laymor, Terremite, Barreto, EZ Trench, Takeuchi, Basic, Bil-Jax, Curtis, Gehl, Heli, Honda, ICS/PowerGrit, Puckett, Waldon, ASV, IHI, Partner, Imer, Clipper, MMD, Koshin, Rice, Gorman Rupp, CH&E, Cat Pumps, Comet, General Pump, Giant, AMida, Coleman, NAC, Gradall, Square Shooter, Kent, Stanley, Tamco, Toku, Hatz, Kohler, Robin, Wisconsin, Northrock, Oztec, Toker TK, Rol-Air, Small Line, Wanco, Yanmar

Introduction

Important

Read, understand and obey the safety rules and operating instructions in the appropriate Operator's Manual on your machine before attempting any maintenance procedure.

Basic mechanical, hydraulic and electrical skills are required to perform most procedures. However, several procedures require specialized skills, tools, lifting equipment and a suitable workshop. In these instances, we strongly recommend that maintenance and repair be performed at an authorized TEREX dealer service center.

Technical Publications

TEREX Corporation has endeavored to deliver the highest degree of accuracy possible. However, continuous improvement of our products is a TEREX policy. Therefore, product specifications are subject to change without notice.

Readers are encouraged to notify TEREX of errors and send in suggestions for improvement. All communications will be carefully considered for future printings of this and all other manuals.

Serial Number Information

TEREX Corporation offers the following manuals for these models:

Title	Part No.
TEREX RL4000 Operator's Manual First Edition	116417
TEREX RL4000 Service Manual First Edition	116473
TEREX RL4000 Part's Manual First Edition	116444
Leroy Somer Manual	116118
Kubota Engine Manual	893020
Axis Manual	116117
Marathon Manual	116188



www.discount-equipment.com

Copyright © 2008 by TEREX Corporation

116473 Rev A September 2008
First Edition, Second Printing

"TEREX" is a registered trademark of TEREX Corporation in the USA and many other countries. "Super Quiet" is a trademark of TEREX Corporation.

 Printed on recycled paper

Printed in U.S.A.

How to Read Your Serial Number

Serial Number Legend

The serial number plate on your RL4000 is located on the cabinet next to the light tower mast.

MANUFACTURED BY/FABRIQUE PAR:
 TEREX ROCK HILL
 590 Huey Road
 Rock Hill, SC 29732



DATE: FEBRUARY 2008
 GVWR / PNBV 1,244 KG (2,743 LBS)
 GAWR / PNBE 1,244 KG (2,743 LBS)
 TIRES / PNEU ST205/75D13 LOAD RANGE C
 RIMS / JANTE 15.0 X 4.5 5H
 COLD TIRES INFL/ 35 PSI / 250 KPA

PRESS, DE GONFL. A FROID 'SINGLE'

THIS VEHICLE CONFORMS TO ALL APPLICABLE U.S. FEDERAL MOTOR VEHICLE SAFETY STANDARDS IN EFFECT ON THE DATE OF MANUFACTURE SHOWN ABOVE.

THIS VEHICLE CONFORMS TO ALL APPLICABLE STANDARDS PRESCRIBED UNDER THE CANADIAN MOTOR VEHICLE SAFETY REGULATIONS IN EFFECT ON THE DATE MANUFACTURE/ CE VEHICULE EST CONFORME A TOUTES LES NORMES QUI LUI SONT APPLICABLES EN VERTU DU REGLEMENT SUR LA SECURITE DES VEHICULES AUTOMOBILES DU CANADA EN VIGUEUR A LA DATE DE SA FABRICATION

TYPE OF VEHICLE / TYPE DE VEHICULE: TRAILER/REMORQUE

MODEL: RL4000
 SERIAL NUMBER: RL408-1003
 MODEL YEAR: 2008

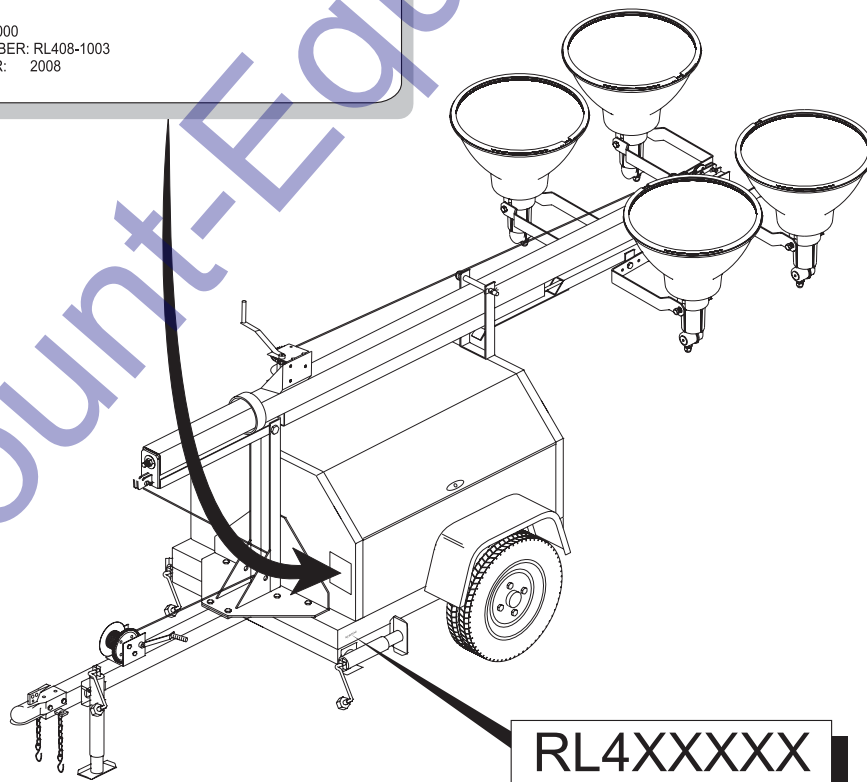

RL4XXXXX
 Serial number is stamped into frame.

 **TEREX**
Safety Rules**Danger**

Failure to obey the instructions and safety rules in this manual and the appropriate Operator's Manual on your machine will result in death or serious injury.

Many of the hazards identified in the operator's manual are also safety hazards when maintenance and repair procedures are performed.

Do Not Perform Maintenance Unless:

- You are trained and qualified to perform maintenance on this machine.
- You read, understand and obey:
 - manufacturer's instructions and safety rules
 - employer's safety rules and worksite regulations
 - applicable governmental regulations
- You have the appropriate tools, lifting equipment and a suitable workshop.

SAFETY RULES

REV A

Personal Safety

Any person working on or around a machine must be aware of all known safety hazards. Personal safety and the continued safe operation of the machine should be your top priority.



Read each procedure thoroughly. This manual and the decals on the machine, use signal words to identify the following:



Safety alert symbol—used to alert personnel to potential personal injury hazards. Obey all safety messages that follow this symbol to avoid possible injury or death.

▲ DANGER

Red—used to indicate the presence of an imminently hazardous situation which, if not avoided, will result in death or serious injury.

▲ WARNING

Orange—used to indicate the presence of a potentially hazardous situation which, if not avoided, could result in death or serious injury.

▲ CAUTION

Yellow with safety alert symbol—used to indicate the presence of a potentially hazardous situation which, if not avoided, may cause minor or moderate injury.

CAUTION

Yellow without safety alert symbol—used to indicate the presence of a potentially hazardous situation which, if not avoided, may result in property damage.

NOTICE

Green—used to indicate operation or maintenance information.



Be sure to wear protective eye wear and other protective clothing if the situation warrants it.



Be aware of potential crushing hazards such as moving parts, free swinging or unsecured components when lifting or placing loads. Always wear approved steel-toed shoes.

Workplace Safety



Be sure to keep sparks, flames and lighted tobacco away from flammable and combustible materials like battery gases and engine fuels. Always have an approved fire extinguisher within easy reach.



Be sure that all tools and working areas are properly maintained and ready for use. Keep work surfaces clean and free of debris that could get into machine components and cause damage.



Be sure that your workshop or work area is properly ventilated and well lit.



Be sure any forklift, overhead crane or other lifting or supporting device is fully capable of supporting and stabilizing the weight to be lifted. Use only chains or straps that are in good condition and of ample capacity.



Be sure that fasteners intended for one time use (i.e., cotter pins and self-locking nuts) are not reused. These components may fail if they are used a second time.



Be sure to properly dispose of old oil or other fluids. Use an approved container. Please be environmentally safe .



Table of Contents

REV A

Introduction

Important Information - Introduction	<i>ii</i>
How to Read Your Serial Number	<i>iii</i>
Parts Stocking List	<i>ix</i>
How to Order Parts	<i>xi</i>
Service Parts Fax Order Form	<i>xii</i>

Section 1**Safety Rules**

General Safety Rules	<i>v</i>
----------------------------	----------

Section 2**Rev****Specifications**

A	Specifications	2 - 1
A	Specifications (Continued)	2 - 2
A	Specifications (Continued)	2 - 3
A	Torque Specifications	2 - 4

Section 3**Rev****Scheduled Maintenance Procedures**

	Introduction	3 - 1
	Pre-delivery Preparation Report	3 - 2
A	Maintenance Schedules	
	Kubota Lubrication and Maintenance Service Intervals	3 - 3
	Leroy Somer Generators Maintenance Schedule	3 - 4
	Marathon Generators Maintenance Schedule	3 - 5

Section 4**Rev****Troubleshooting**

	Introduction	4 - 1
A	Troubleshooting Guide	4 - 2

TABLE OF CONTENTS

REV A

Section 5	Rev	Schematics	
	A	Introduction	5 - 1
	A	AC Light Tower Wiring	5 - 2
	A	Wire Harness, Control Box, European, DC	5 - 3
	A	DC Wiring, European, Kubota	5 - 4
	A	DC Wiring, Kubota	5 - 5
	A	Wire Harness, Inside Control Box, DC	5 - 6
	A	MH or HPS Light Fixture	5 - 7
	A	1000 MH Ballast	5 - 8
	A	1000 HPS Ballast	5 - 9

Parts Stocking List

REV A

Required Parts

The following parts are required to perform maintenance procedures as outlined in the *TEREX RL4000 Parts and Service Manuals*.

Description	Part No.
Kubota Models	
Oil Filter	866050
Air Filter	866127
Fuel Filter	839200
V-belt	839209

Discount-Equipment.com

Discount Equipment

Discount-Equipment.com is your online resource for commercial and industrial quality parts and equipment sales.

Locations:

Florida (West Palm Beach): [561-964-4949](tel:561-964-4949)

Outside Florida TOLL FREE: [877-690-3101](tel:877-690-3101)

Need parts? Check out our website at www.discount-equipment.com

Can't find what you need?

Click on this link: <http://www.discount-equipment.com/category/5443-parts/> and fill out the request form.

Please have the machine model and serial number available in order to help us get you the correct parts. One of our experienced staff members will get back to you with a quote for the right part that your machine needs.

We sell worldwide for the brands: Genie, Terex, JLG, MultiQuip, Mayco, Toro/Stone, Diamond Products, Magnum, Airman, Mustang, Power Blanket, Nifty Lift, Atlas Copco, Chicago Pneumatic, Allmand Brothers, Essick, Miller Spreader, Skyjack, Lull, Skytrak, Tsurumi, Husquyarna/Target, Whiteman-Concrete/Mortar, Stow-Concrete/Mortar, Baldor, Wacker, Sakai, Snorkel, Upright, Mi-T-M, Sullair, Neal, Basic, Dynapac, MBW, Weber, Bartell, Bennar Newman, Haulotte, Ditch Runner, Blaw-Knox, Himoina, Best, Buddy, Crown, Edco, Wyco, Bomag, Laymor, Terremite, Barreto, EZ Trench, Takeuchi, Basic, Bil-Jax, Curtis, Gehl, Heli, Honda, ICS/PowerGrit, Puckett, Waldon, ASV, IHI, Partner, Imer, Clipper, MMD, Koshin, Rice, Gorman Rupp, CH&E, Cat Pumps, Comet, General Pump, Giant, AMida, Coleman, NAC, Gradall, Square Shooter, Kent, Stanley, Tamco, Toku, Hatz, Kohler, Robin, Wisconsin, Northrock, Oztec, Toker TK, Rol-Air, Small Line, Wanco, Yanmar

**TEREX**

Specifications

REV A

MAST	
MAST ELEVATION	30' / 9.14M
TOWER ROTATION	359 DEGREES
TOWER ROTATION	MANUAL
MAX WIND RATING	62MPH / 100KPH
DIMENSIONS	
	SEE CHART ON PAGE 2-3
ENGINES	
STANDARD	KUBOTA, D1105 DIESEL, 13.6 HP
GENERATORS	
STANDARD	MARATHON, 6 KW 201CSA5411, 60HZ
OR	LEROY SOMER 36M6, 6KW, 60HZ
STANDARD RECEPTACLES	
	QTY. 1, 120V, 20A, GFI, DUPLEX QTY. 1, 240V, 30A, TWISTLOCK
STANDARD BREAKERS	
	QTY. 4, 1P, 15A, LAMPS QTY. 1, 2P, 30A, MAIN QTY. 1, MINI, 1P, 20A, GFI RECEPTACLE
STANDARD LAMPS	
	SEPARATELY SWITCHED QTY. 4, 1000 WATT METAL HALIDE, ROUND

SPECIFICATIONS

REV A

TRAILER	
	WHEELS 13 X 4.5, 5 HOLE TIRES, ST175/80D13, LOAD B COLD PRESSURE, 35PSI / 250KPA AXLE RATING 2000LBS MAX TOW SPEED, 60MPH / 96KPH NO BRAKES, STANDARD TWO OUTRIGGERS, STANDARD
FUEL TANK	
	FUEL TYPE, NO.2 DIESEL ONLY CAPACITY, 30 GALLONS / 114L MATERIAL, POLYETHELENE
FUEL CONSUMPTION	
	KUBOTA, .787 G/HR - 2.97L/HR KUBOTA, RUN TIME, 30 GAL.= 38.3 HRS.
WEIGHT	
	6KW, TOTAL WEIGHT, NO FUEL, 1,725LBS. / 783KG 6KW, TOTAL WEIGHT, TANK FULL, 1,935LBS. / 878KG
TONGUE WEIGHT	
	6KW, 30 GALLON, 199LBS / 91KG WITH FUEL
BATTERY	
	WET, 12V, GROUP 24, 460 CCA, STD-DUTY, LEAD ACID

REV A

SPECIFICATIONS

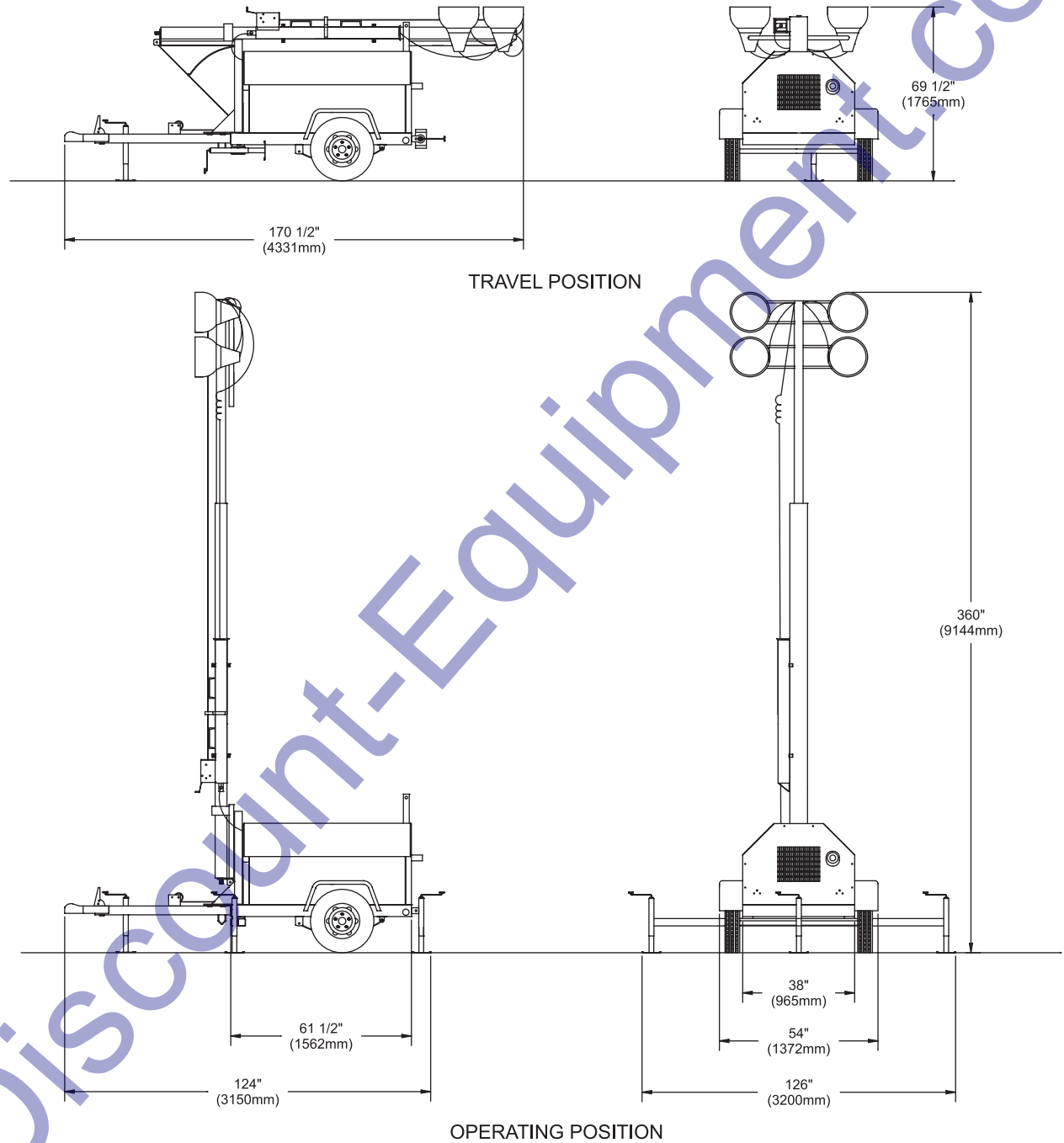

SAE FASTENER TORQUE CHART											
• This chart is to be used as a guide only unless noted elsewhere in this manual •											
SIZE	THREAD	Grade 5				Grade 8				A574 High Strength Black Oxide Bolts	
		LUBED		DRY		LUBED		DRY		LUBED	
		in-lbs	Nm	in-lbs	Nm	in-lbs	Nm	in-lbs	Nm	in-lbs	Nm
1/4	20	100	11.3	80	9	140	15.8	110	12.4	130	14.7
	28	90	10.1	120	13.5	120	13.5	160	18	140	15.8
		LUBED		DRY		LUBED		DRY		LUBED	
		ft-lbs	Nm	ft-lbs	Nm	ft-lbs	Nm	ft-lbs	Nm	ft-lbs	Nm
5/16	18	13	17.6	17	23	18	24	25	33.9	21	28.4
	24	14	19	19	25.7	20	27.1	27	36.6	24	32.5
3/8	16	23	31.2	31	42	33	44.7	44	59.6	38	51.5
	24	26	35.2	35	47.4	37	50.1	49	66.4	43	58.3
7/16	14	37	50.1	49	66.4	50	67.8	70	94.7	61	82.7
	20	41	55.5	55	74.5	60	81.3	80	108.4	68	92.1
1/2	13	57	77.3	75	101.6	80	108.4	110	149	93	126
	20	64	86.7	85	115	90	122	120	162	105	142
9/16	12	80	108.4	110	149	120	162	150	203	130	176
	18	90	122	120	162	130	176	170	230	140	189
5/8	11	110	149	150	203	160	217	210	284	180	244
	18	130	176	170	230	180	244	240	325	200	271
3/4	10	200	271	270	366	280	379	380	515	320	433
	16	220	298	300	406	310	420	420	569	350	474
7/8	9	320	433	430	583	450	610	610	827	510	691
	14	350	474	470	637	500	678	670	908	560	759
1	8	480	650	640	867	680	922	910	1233	770	1044
	12	530	718	710	962	750	1016	990	1342	840	1139
1.125	7	590	800	790	1071	970	1315	1290	1749	1090	1477
	12	670	908	890	1206	1080	1464	1440	1952	1220	1654
1.25	7	840	1138	1120	1518	1360	1844	1820	2467	1530	2074
	12	930	1260	1240	1681	1510	2047	2010	2725	1700	2304
1.5	6	1460	1979	1950	2643	2370	3213	3160	4284	2670	3620
	12	1640	2223	2190	2969	2670	3620	3560	4826	3000	4067

METRIC FASTENER TORQUE CHART																
• This chart is to be used as a guide only unless noted elsewhere in this manual •																
Size (mm)	Class 4.6				Class 8.8				Class 10.9				Class 12.9			
	LUBED		DRY		LUBED		DRY		LUBED		DRY		LUBED		DRY	
	in-lbs	Nm	in-lbs	Nm	in-lbs	Nm	in-lbs	Nm	in-lbs	Nm	in-lbs	Nm	in-lbs	Nm	in-lbs	Nm
5	16	1.8	21	2.4	41	4.63	54	6.18	58	6.63	78	8.84	68	7.75	91	10.3
6	19	3.05	36	4.07	69	7.87	93	10.5	100	11.3	132	15	116	13.2	155	17.6
7	45	5.12	60	6.83	116	13.2	155	17.6	167	18.9	223	25.2	1.95	22.1	260	29.4
	LUBED		DRY		LUBED		DRY		LUBED		DRY		LUBED		DRY	
	ft-lbs	Nm	ft-lbs	Nm	ft-lbs	Nm	ft-lbs	Nm	ft-lbs	Nm	ft-lbs	Nm	ft-lbs	Nm	ft-lbs	Nm
8	5.4	7.41	7.2	9.88	14	19.1	18.8	25.5	20.1	27.3	26.9	36.5	23.6	32	31.4	42.6
10	10.8	14.7	14.4	19.6	27.9	37.8	37.2	50.5	39.9	54.1	53.2	72.2	46.7	63.3	62.3	84.4
12	18.9	25.6	25.1	34.1	48.6	66	64.9	88	69.7	94.5	92.2	125	81	110	108	147
14	30.1	40.8	40	54.3	77.4	105	103	140	110	150	147	200	129	175	172	234
16	46.9	63.6	62.5	84.8	125	170	166	226	173	235	230	313	202	274	269	365
18	64.5	87.5	86.2	117	171	233	229	311	238	323	317	430	278	377	371	503
20	91	124	121	165	243	330	325	441	337	458	450	610	394	535	525	713
22	124	169	166	225	331	450	442	600	458	622	612	830	536	727	715	970
24	157	214	210	285	420	570	562	762	583	791	778	1055	682	925	909	1233



Scheduled Maintenance Procedures

REV A



Observe and Obey:

- ☑ Maintenance inspections shall be completed by a person trained and qualified on the maintenance of this machine.
- ☑ Scheduled maintenance inspections shall be completed as specified using the supplied *Lubrication and Maintenance Service Interval Charts* provided in this section.

AWARNING Failure to perform each procedure as presented and scheduled could result in death, serious injury or substantial damage.

- ☑ Immediately tag and remove from service a damaged or malfunctioning machine.
- ☑ Repair any machine damage or malfunction before operating the machine.
- ☑ Keep records on all inspections for three years.
- ☑ Machines that have been out of service for a period longer than 3 months must complete the quarterly inspection.
- ☑ Unless otherwise specified, perform each maintenance procedure with the machine in the following configuration:
 - Machine parked on a firm, level surface
 - Toggle switch in the "OFF" position
 - Wheels chocked

About This Section

This section contains detailed procedures for each scheduled maintenance inspection.

Each procedure includes a description, safety warnings and step-by-step instructions.

Symbols Legend



Safety alert symbol—used to alert personnel to potential personal injury hazards. Obey all safety messages that follow this symbol to avoid possible injury or death.



Red—used to indicate the presence of an imminently hazardous situation which, if not avoided, will result in death or serious injury.



Orange—used to indicate the presence of a potentially hazardous situation which, if not avoided, could result in death or serious injury.



Yellow with safety alert symbol—used to indicate the presence of a potentially hazardous situation which, if not avoided, may cause minor or moderate injury.



Yellow without safety alert symbol—used to indicate the presence of a potentially hazardous situation which, if not avoided, may result in property damage.



Green—used to indicate operation or maintenance information.

- ⦿ Indicates that a specific result is expected after performing a series of steps.
- ⊗ Indicates that an incorrect result has occurred after performing a series of steps.

Pre-Delivery Preparation

Fundamentals

It is the responsibility of the dealer to perform the Pre-delivery Preparation.

The Pre-delivery Preparation is performed prior to each delivery. The inspection is designed to discover if anything is apparently wrong with a machine before it is put into service.

A damaged or modified machine must never be used. If damage or any variation from factory delivered condition is discovered, the machine must be tagged and removed from service.

Repairs to the machine may only be made by a qualified service technician, according to the manufacturer's specifications.

Scheduled maintenance inspections shall be performed by qualified service technicians, according to the manufacturer's specifications and the requirements listed in the responsibilities manual.

Instructions

Use the operator's manual on your machine.

The Pre-delivery Preparation consists of completing the Pre-operation Inspection, the Maintenance items and the Function Tests.

Use this form to record the results. Place a check in the appropriate box after each part is completed. Follow the instructions in the operator's manual.

If any inspection receives an N, remove the machine from service, repair and re-inspect it. After repair, place a check in the R box.

Legend

Y = yes, completed

N = no, unable to complete

R = repaired

Comments

Pre-Delivery Preparation	Y	N	R
Pre-operation inspection completed			
Maintenance items completed			
Function tests completed			

Model

Serial number

Date

Machine owner

Inspected by (print)

Inspector signature

Inspector title

Inspector company





Maintenance Schedules

REV A

Kubota Lubrication and Maintenance Service Intervals

ITEM	Every 50 Hours	Every 100 Hours	Every 200 Hours	Every 400 Hours	Every 500 Hours	Every Year	Every 800 Hours	Every 1500 Hours	Every 3000 Hours	Every Two Years
Check of fuel pipes and clamp bands	•									
Check engine oil and coolant level	•									
Cleaning of air cleaner element		•								
Check of battery electrolyte level		•								
Check of fan belt tightness		•								
Check of radiator hoses and clamp bands			•							
Check of intake air line			•							
Replacement of oil filter cartridge				•						
Replacement of fuel filter cartridge				•						
Removal of sediment in fuel tank					•					
Cleaning of water jacket (radiator interior)					•					
Replacement of fan belt					•					
Replacement of air cleaner element						•				
Check of damage in electric wiring and loose connections						•				
Check of valve clearance							•			
Check of fuel injection nozzle injection pressure								•		
Check of turbo charger									•	
Check of injection pump									•	
Check of injection timer									•	
Change of radiator coolant (L.L.C.)										•
Replacement of battery										•
Replacement of radiator hoses and clamp bands										•
Replacement of fuel pipes and clamp bands										•
Replacement of intake air line										•

*Refer to the manufacturer's manuals for detailed maintenance intervals and instructions. If the information in the manufacturer's manual differs from that in this manual the manufacturer's manual should take precedence.

MAINTENANCE SCHEDULES CONTINUED

REV A

Leroy Somer Generators Maintenance Schedule

ITEM	DAILY	Weekly	2000 Hours or 6 Months	8000 Hours or 1 Year	20000 Hours or 3 Years	30000 Hours or 5 Years
Inspect and verify operator reports	•					
Visual inspection of generator housing and air inlet/outlets	•					
Visually inspect installation for sign of particulate or liquid contaminant intrusion.	•					
Check control panel voltmeter for proper stability and voltage output. Monitor the power factor and generator loading during operation.	•					
Visually inspect the generator non-drive end bearing exterior for dirt, and clean if necessary.		•				
If installed, inspect any generator air filters for build up of contaminants, and clean or replace as required.		•				
Visually inspect the stator output leads and insulation for cracking or damage.			•			
Check all exposed electrical connections for tightness.			•			
Check transformers, fuses, capacitors, and lightning arrestors for loose or physical damage.			•			
Check all lead wires and electrical connections for proper clearance and spacing.			•			
Clean the inside of the outlet box, air screens and air baffles with compressed air or electrical solvent if needed.			•			
Check machine vibrations and bearing condition against those established and recorded during original commissioning period or as defined by OEM.			•			
Check IR (insulation resistance) to ground on all generator windings, including the main rotating assembly, the main stator assembly, the exciter field and armature assemblies, and any optional PMG assembly - record				•		
Remove the end brackets and visually inspect the generator end windings for oil or dirt contamination. Excessive contamination may necessitate surface cleaning*.					•	
Disassemble the generator (this includes rotor removal).						•
Clean the generator windings.						•
Replace the bearings						•

*Refer to the manufacturer's manuals for detailed maintenance intervals and instructions. If the information in the manufacturer's manual differs from that in this manual the manufacturer's manual should take precedence.



REV A

Marathon Generators Maintenance Schedule

ITEM	DAILY	200 Hours	10000 Hours
Visual inspection	•		
Clean and inspect after every 200 hours of normal operating time. If generator is housed in a harsh environment, it is advisable to clean and inspect the unit more frequently.		•	
Replace the bearing			•

*Refer to the manufacturer's manuals for detailed maintenance intervals and instructions. If the information in the manufacturer's manual differs from that in this manual the manufacturer's manual should take precedence.



Troubleshooting

REV A



Observe and Obey:

- ☑ Troubleshooting and repair procedures shall be completed by a person trained and qualified on the repair of this machine.
- ☑ Immediately tag and remove from service a damaged or malfunctioning machine.
- ☑ Repair any machine damage or malfunction before operating the machine.
- ☑ Unless otherwise specified, perform each repair procedure with the machine in the following configuration:
 - Machine parked on a firm, level surface.
 - Wheels chocked.
 - Toggle switch in "OFF" position.

Before Troubleshooting:

- ☑ Read, understand and obey the safety rules and operating instructions in the appropriate operator's manual on your machine.
- ☑ Be sure that all necessary tools and test equipment are available and ready for use.
- ☑ Be aware of the following hazards and follow generally accepted safe workshop practices.

⚠ DANGER

Electrocution hazard. Exposure to electrically charged circuits could result in death or serious injury. Remove all rings, watches and other jewelry.

⚠ DANGER

Electrocution hazard. Attempting to service the machine before the capacitors are fully discharged will result in death or serious injury.

⚠ DANGER

High voltage. Exposure to electrical wires or electrical current will result in death or serious injury. Remove all rings, watches and other jewelry. Turn off all power when not needed for testing. Use extreme caution when working with high voltage electrical components.

⚠ CAUTION

Burn hazard. Contact with hot engine components may cause severe burns. Use caution when working around a hot engine.

Troubleshooting Guide

The engine/generator set is tested and set at the factory for proper operation in the field. These units should never require additional adjustments in the field. If needed, adjustments should only be made by a qualified service technician, otherwise the manufacturer's warranty may become void.

TROUBLE	POSSIBLE CAUSE	REMEDY
1. Boom will not rise to the operating position.	a. Yoke pin is in place	a. Remove yoke pin
	b. Defective cable or pulley	b. Have a trained mechanic examine and repair as needed
	c. Defective winch	c. Have a trained mechanic examine and replace as needed
2. Boom will not telescope.	a. Defective winch	a. Have a trained mechanic examine and replace as needed
	b. Broken cable or pulley	b. Have a trained mechanic examine and replace as needed
3. Engine will not turn over	a. Dead battery	a. Check the battery voltage or loose cables
	b. Engine has seized due to loss of fluids	b. Have a trained mechanic examine and repair as needed
4. Engine turns over but will not start	a. Empty fuel tank	a. Fill tank with #2 diesel fuel
	b. Clogged fuel lines or filter	b. Check and clean the fuel system as needed
	c. Leaking fuel lines or a loss of prime	c. Replace any leaking fuel lines and tighten connections
	d. Heater elements burned out	d. Replace heater elements
	e. Fuel line solenoid is not open	e. Replace fuel line solenoid
5. Engine runs rough	a. Clogged or leaking fuel system	a. Replace fuel lines, tighten all connections, inspect the pickup tube and inspect the fuel filter
	b. Clogged exhaust system	b. Clear the exhaust system
	c. Clogged air filter	c. Clear air filter
	d. Clogged or stuck fuel injectors	d. Have a trained mechanic examine
	e. Valve clearances are out of adjustment or the valve spring may be damaged	e. Have a trained mechanic examine
	f. Defective governor or fuel pump	f. Have a trained mechanic examine

REV A

TROUBLESHOOTING

TROUBLE	POSSIBLE CAUSE	REMEDY
6.Engine runs but produces a dense smoke	a.Crankcase oil level is too high	a.Drain oil to its proper level
	b.Low compression	b.Have a trained mechanic inspect for broken or seized rings. Inspect valve clearances
	c. Clogged air cleaner	c. Replace air cleaner element
7.Engine overheats	a.Blocked cooling air intakes	a.Inspect the front and rear intakes and clear as needed
	b.Low coolant levels	b.Replace the coolant with a 50% water/coolant solution
	c.Radiator fins have become clogged	c.Clear the radiator fins
	d.Fan belt is loose	d.Tighten fan belt
8.Engine runs but the battery voltage is low	a.Alternator has failed	a.Have a trained mechanic inspect the alternator
9.Engine runs but the lights will not operate	a.Circuit breakers are tripped	a.Reset the circuit breaker
	b.Loose connections in the wiring system	b.Have a trained electrician inspect the ballast box wiring system
	c.Burned out bulb	c.Replace the bulbs as needed
	d.Defective capacitor (Leroy Somers Generator)	d.Have a trained electrician inspect the capacitor
	e.Defective AC generator	e.Have a trained electrician inspect the generator
	f.Engine speed is too low	f.Have a trained mechanic inspect the engine speed and reset to 1800rpm @ 60hz
	g.Defective ballast and capacitors	g.Have a trained electrician inspect the ballast and capacitors
10.Unusual noise coming from the generator	a.The generator has a defective bearing or damaged fan blade	a.Have a trained electrician inspect the generator
11.Lamp will not start	a.Lamp loose in socket	a.Inspect lamp base to see if there is arcing at center contact button. Tighten lamp. Check socket for damage. Replace if needed.
	b.Floodlight plugs not tight	b.Check plug and receptacle. Tighten if needed. Make sure power is off.
	c.Defective ballast	c.Interchange ballast plugs. If lamp starts, replace ballast. Check for swollen capacitors, charred wiring, core and coil, or other signs of excessive heat.
	d.Low voltage	d.Check line voltage at ballast input. Voltage should be within 10% of rating when operating at normal load. Increase supply voltage or remove external load.

TROUBLESHOOTING

REV A

TROUBLE	POSSIBLE CAUSE	REMEDY
11. Lamp will not start	e. Improper ballast	e. The ballast name plate data should agree with the line voltage and lamp used. If not, replace the ballast.
	f. Lamp has been operating; cool down time insufficient	f. Switch off breaker and allow lamp to cool.
12. Lamp starts slowly (arc does not strike when switch is first turned on)	a. Defective lamp	a. Lamp may glow for an extended period of time. Replace after checking voltage and ballast
13. Circuit breaker trips on lamp startup	a. Short circuit or ground	a. Check wiring against diagram. inspect for shorts or ground. Fix as needed.
14. Lamp light output low	a. Normal lamp depreciation	a. Replace lamp
	b. Dirty lamp or fixture	b. Clean lamp and fixture
	c. Defective ballast	c. Interchange ballast plugs. If lamp starts, replace ballast. Check for swollen capacitors, charred wiring, core and coil, or other signs of excessive heat.
	d. Wrong voltage	d. Check line voltage at ballast input. Voltage should be within 10% of rating when operating at normal load. Check wiring connections for voltage loss. Check socket contact point.
	e. Improper ballast	e. Check ballast name plate against lamp data
15. Lamp colors different	a. Normal lamp depreciation	a. Replace lamp
	b. Dirty lamp or fixture	b. Clean lamp and fixture
	c. Wrong lamp	c. Check data on lamps and replace as needed.
16. Arc tube discolored or swollen	a. Over voltage from power supply	a. Check voltage at ballast, for current or voltage surges, for shorted capacitors and replace as needed
	b. Improper ballast	b. Check ballast name plate against lamp data
17. Short lamp life	a. Lamp damaged	a. Check for outer bulb cracks, cracks where lamp meets base, and for broken arc tube or loose metal parts. Replace as needed.
	b. Improper ballast	b. Check ballast name plate against lamp data
18. Lamp flickers or goes out-intermittent or cycling	a. Improper Ballast	a. Check ballast name plate against lamp data
	b. New lamp	b. Under certain conditions new lamps may "cycle". Usually after 3 tries to start at 30 to 60 second intervals, lamp will stabilize and operate normal



REV A

TROUBLESHOOTING

TROUBLE	POSSIBLE CAUSE	REMEDY
18. Lamp flickers or goes out-intermittent or cycling	c. Defective lamp	c. Replace lamp
	d. High spike ballast	d. Ballast produces high spike current. Measure with oscilloscope. Replace ballast as required.

IF YOU FEEL AN ELECTRIC SHOCK AT ANY TIME WHILE OPERATING THIS UNIT, SHUT IT DOWN IMMEDIATELY! HAVE THE UNIT INSPECTED BY A TRAINED ELECTRICIAN.

THIS ENGINE/GENERATOR SET IS FACTORY INSTALLED, TESTED, AND SET FOR FIELD OPERATION. ANY DAMAGE TO THE ENGINE OR GENERATOR UNITS OCCURRING AFTER ADJUSTMENTS ARE MADE IN THE FIELD BY UNAUTHORIZED PERSONNEL WILL NOT BE COVERED BY YOUR MANUFACTURER'S WARRANTY AND WILL ALSO VOID THE MANUFACTURER'S WARRANTY ON THIS PARTICULAR UNIT. IF YOU CAN NOT REACH YOUR LOCAL DEALER, CONTACT THE FACTORY SERVICE MANAGER TOLL FREE AT 1-800-433-3026.

Light Fixture Troubleshooting



DO NOT OPEN FIXTURE WHILE LIGHT CIRCUIT BREAKER IS "ON". ALLOW LAMP TO COOL BEFORE TOUCHING.

****TAKE EXTRA PRECAUTIONS WHEN TROUBLESHOOTING ELECTRICAL PROBLEMS****

- A. Only use a voltmeter with two well-insulated pin probes rated for 600 volts.
- B. Treat all conductors as potentially hot.
- C. Proceed through circuits systematically, operating only one section at a time.
- D. Before disconnecting ballast, turn off circuit breaker and wait 30 seconds for capacitor to discharge.
- E. If all the lights are out and all the ballasts are receiving power, suspect burned out power cable.



Schematics

REV A



Observe and Obey:

- ☑ Troubleshooting and repair procedures shall be completed by a person trained and qualified on the repair of this machine.
- ☑ Immediately tag and remove from service a damaged or malfunctioning machine.
- ☑ Repair any machine damage or malfunction before operating the machine.

Before Troubleshooting:

- ☑ Read, understand and obey the safety rules and operating instructions in the appropriate operator's manual on your machine.
- ☑ Be sure that all necessary tools and test equipment are available and ready for use.

About This Section

There are two groups of schematics in this section. An illustration legend precedes each group of drawings.

Electrical Schematics

▲WARNING

Electrocution hazard. Contact with electrically charged circuits could result in death or serious injury. Remove all rings, watches and other jewelry.

General Repair Process

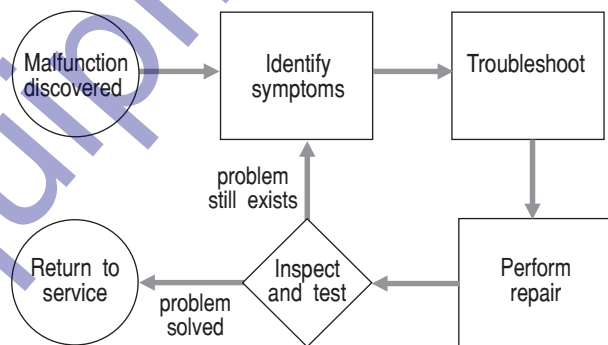

AC Light Tower Wiring

Drawing #6495

REV A

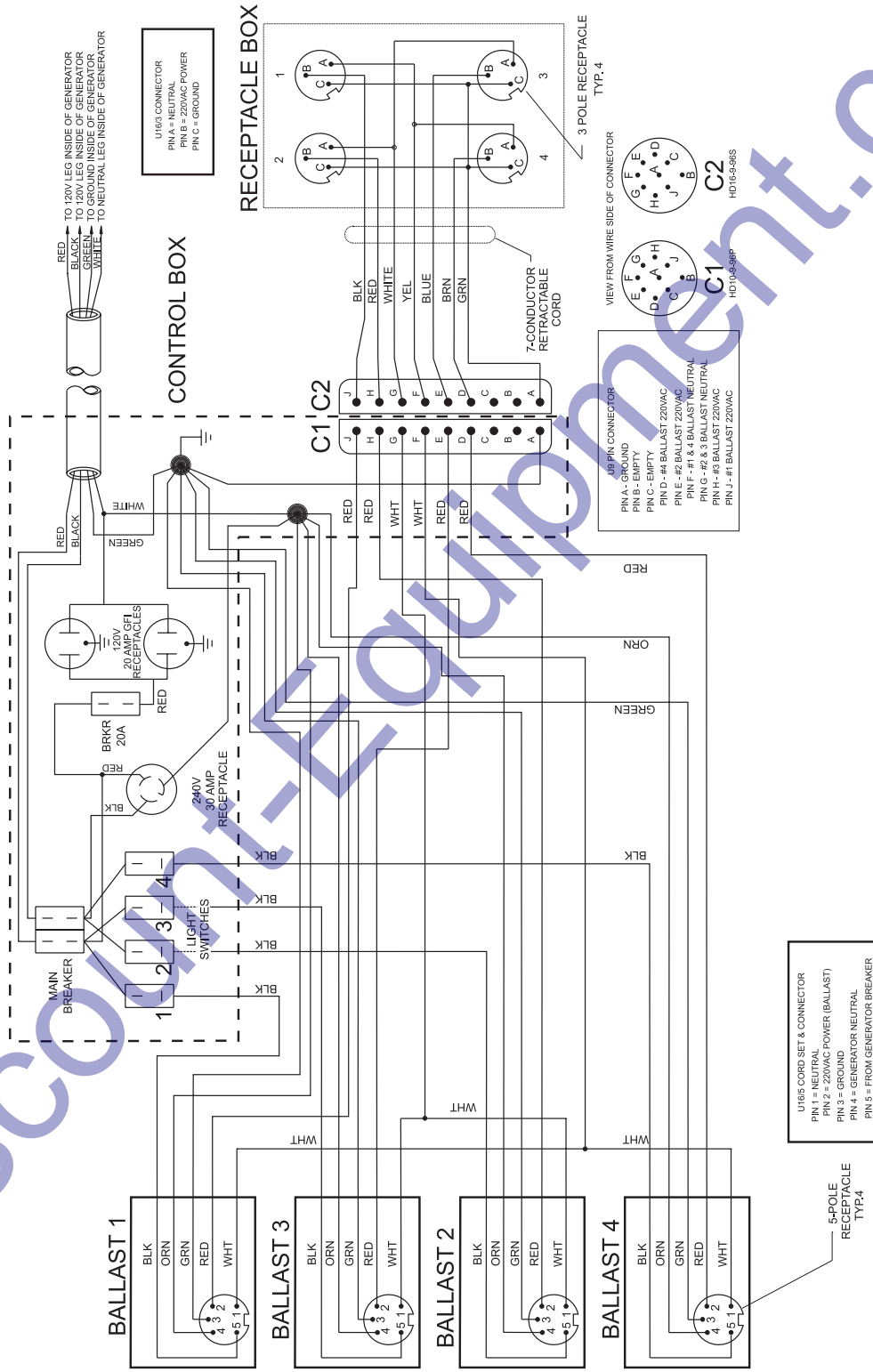

DiscoveryEquipment.com



Wire Harness, Control Box, European, DC

REV A

Drawing #116810

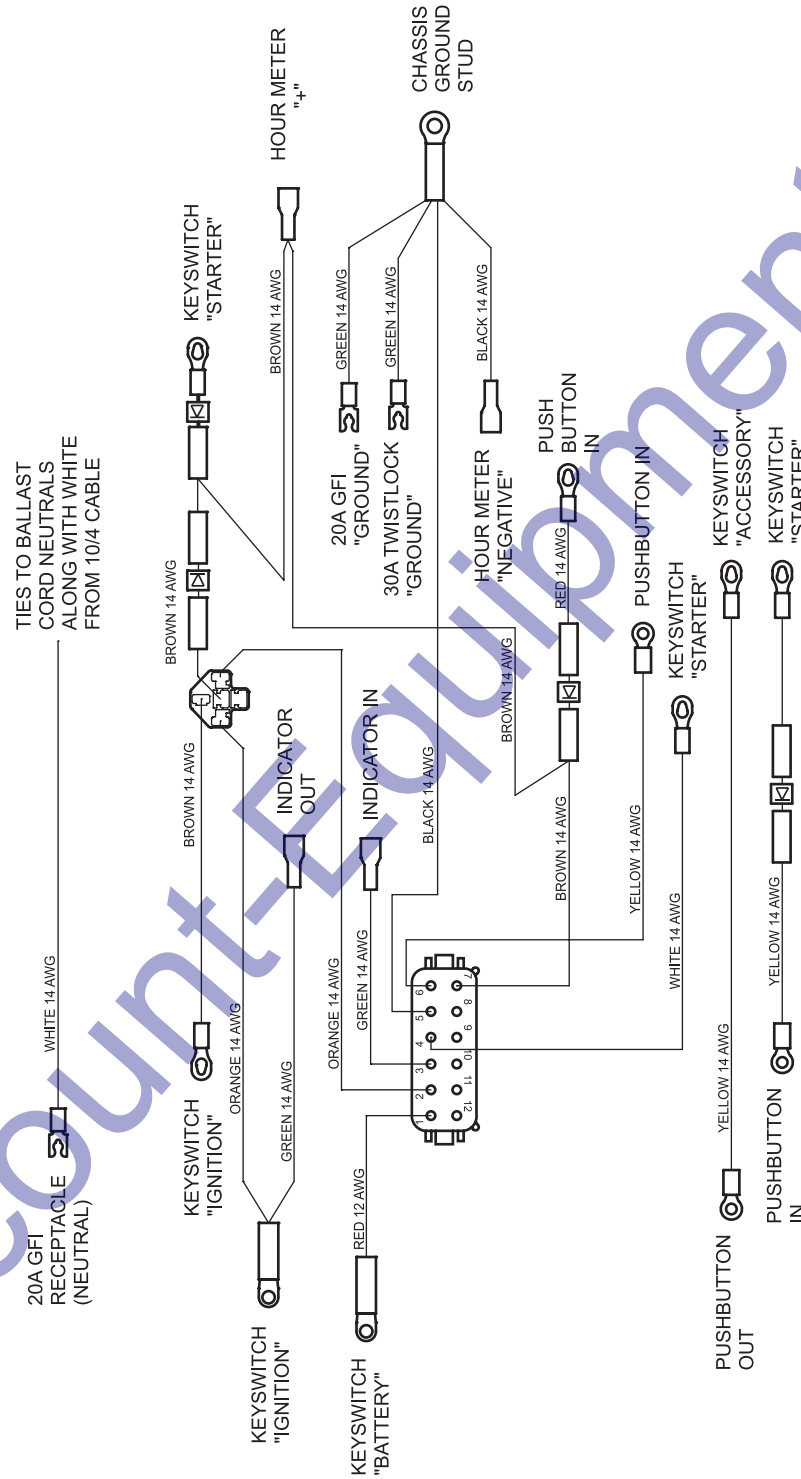

TERMINATION INFO

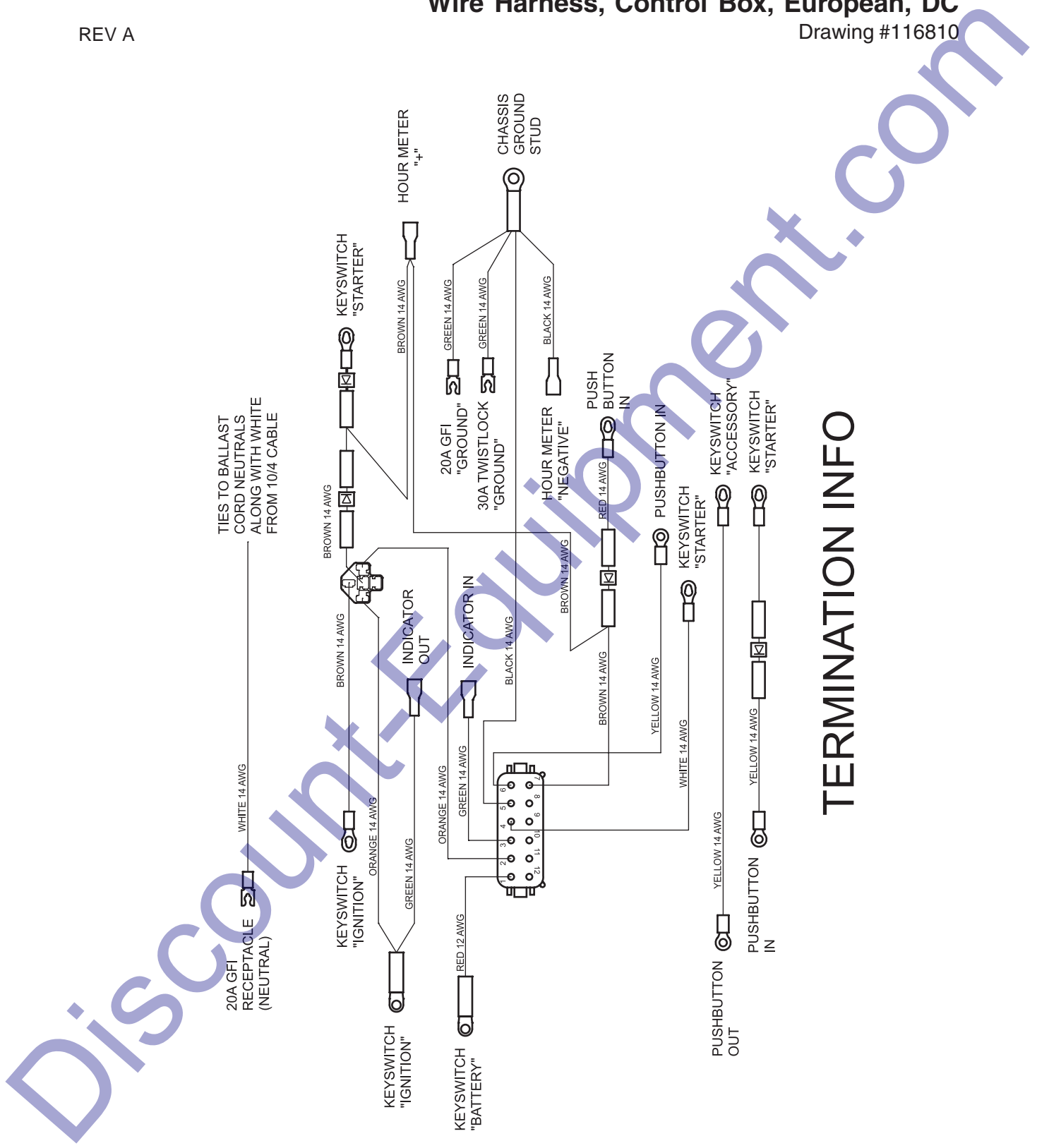

DC Wiring, European, Kubota

Drawing #116813

REV A

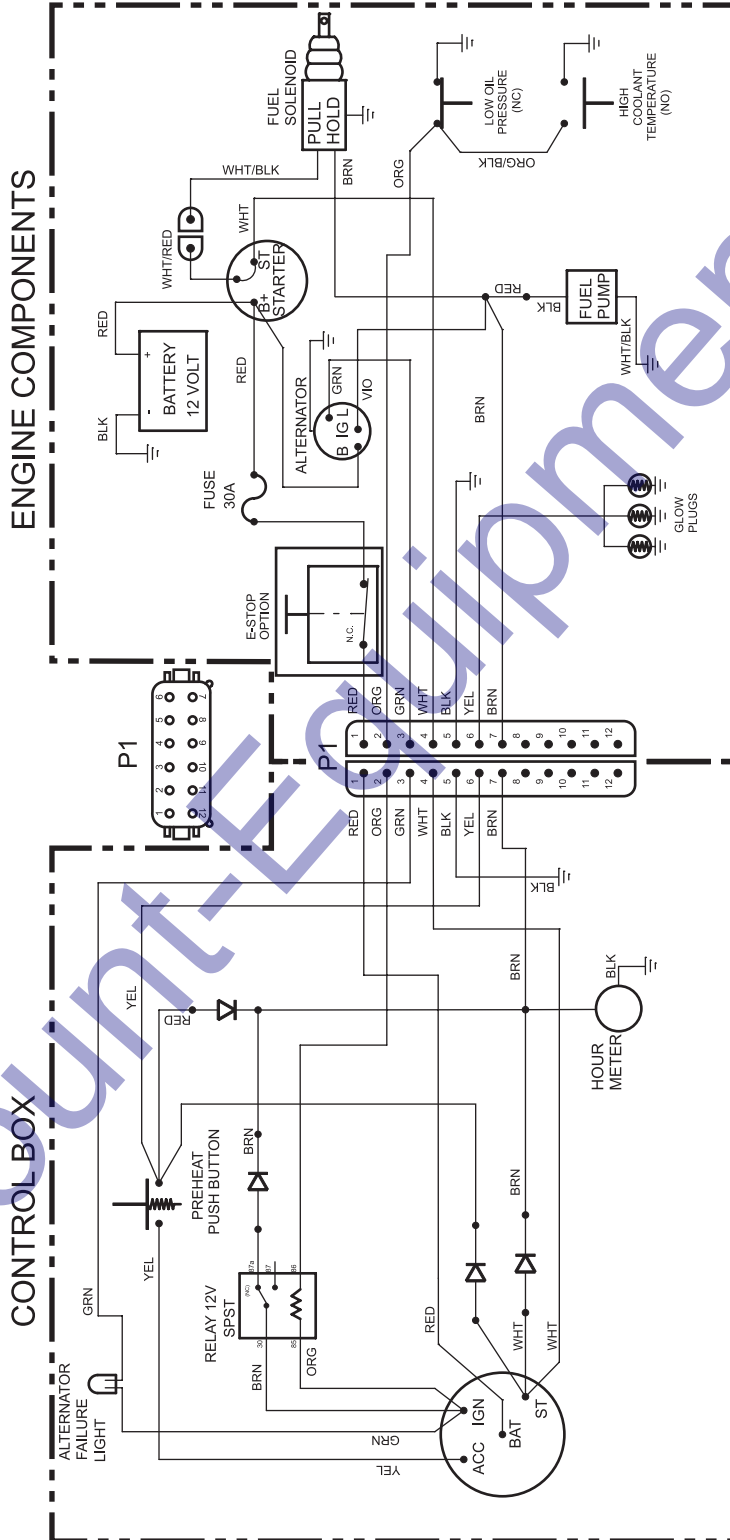



DC Wiring, Kubota

Drawing #116814

REV A

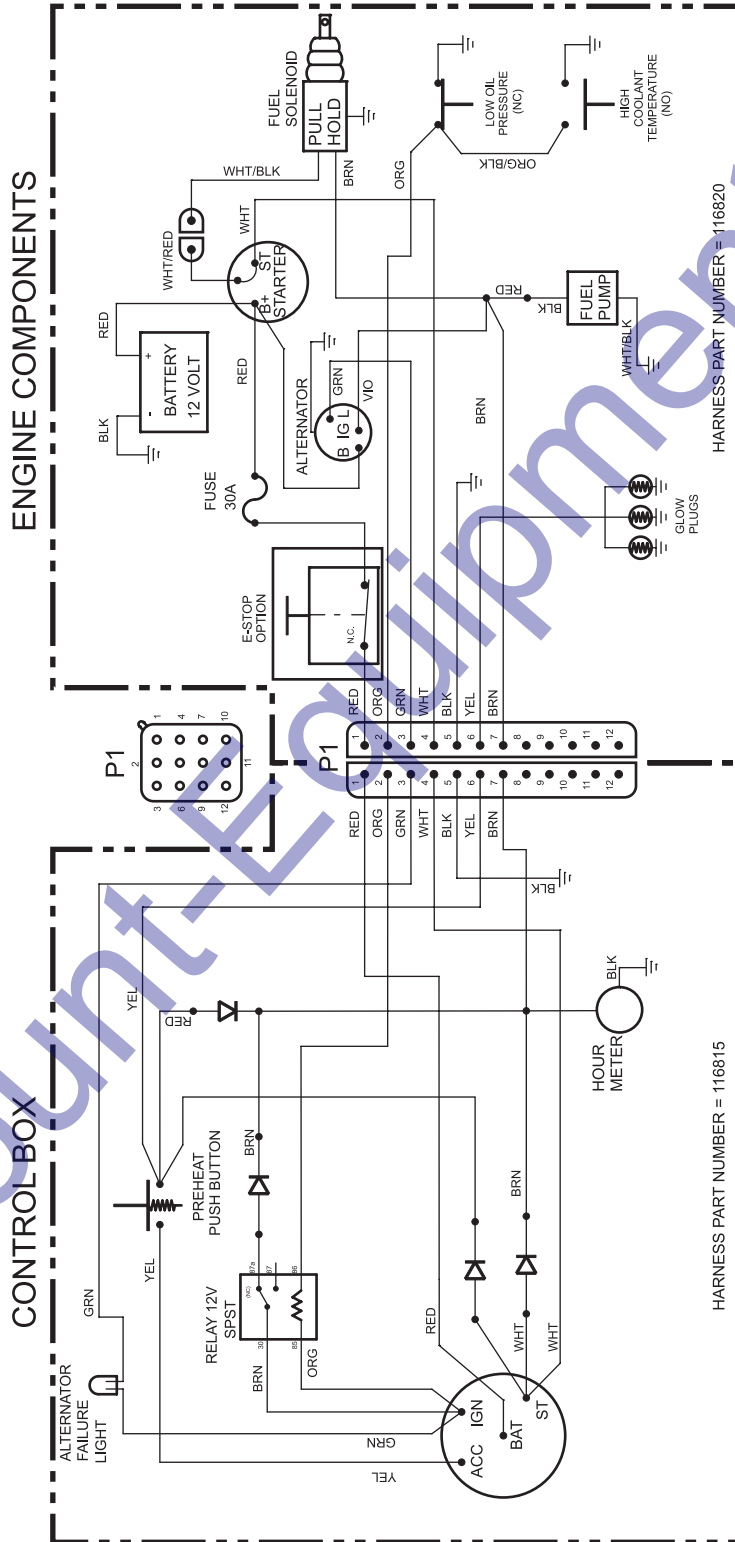

HARNESS PART NUMBER = 116820

HARNESS PART NUMBER = 116815

Wire Harness, Inside Control Box, DC

Drawing #116815

REV A

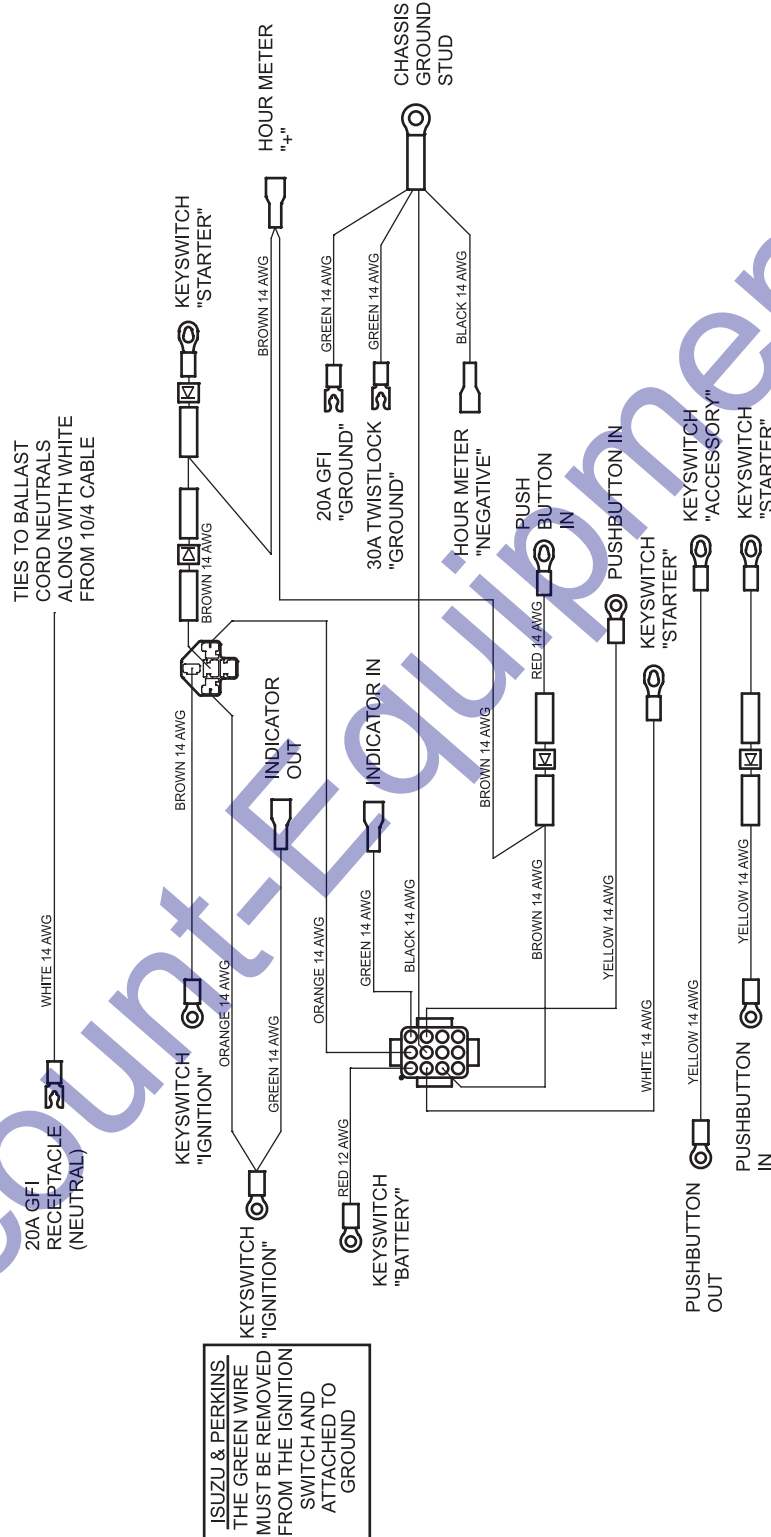

TERMINATION INFO

ISUZU & PERKINS
 THE GREEN WIRE
 MUST BE REMOVED
 FROM THE IGNITION
 SWITCH AND
 ATTACHED TO
 GROUND



MH or HPS Light Fixture

Drawing #2985A

REV A

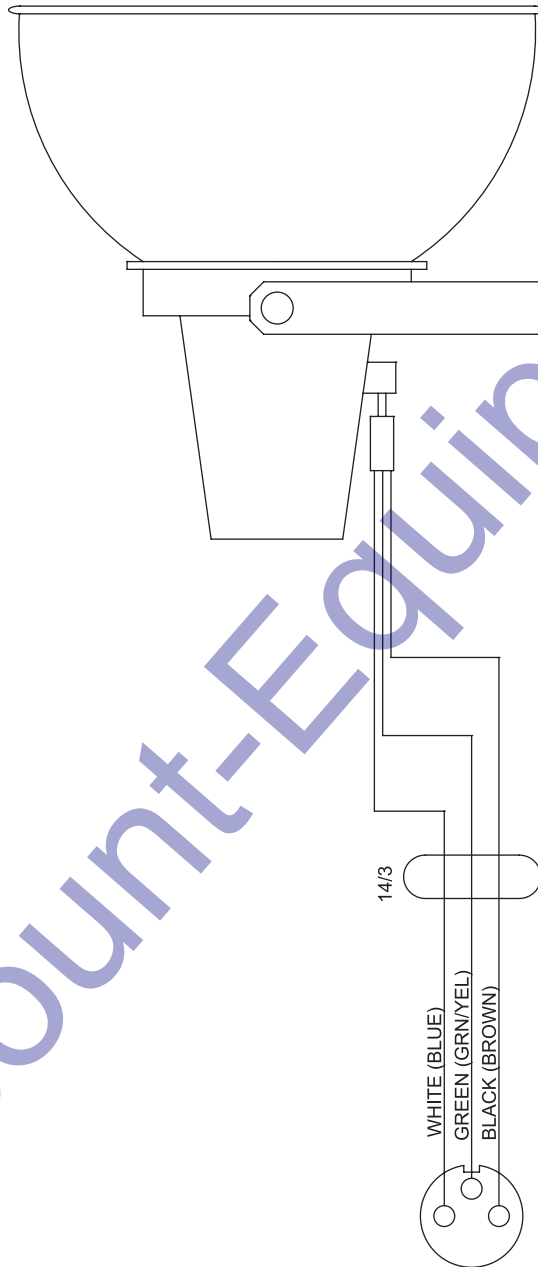

NOTE:
PIN CONFIGURATION IS THE SAME
FOR TUNGSTEN HALOGEN FIXTURES

DOMESTIC COLOR UCODE	EUROPEAN COLOR UCODE	UCIRCUIT
WHITE	LIGHT BLUE	COMMON FROM BALLAST
BLACK	BROWN	HOT FROM BALLAST (LIVE)
GREEN	GREEN W/YELLOW	GROUND (EARTH)

Discount-Equipment.com

1000 MH Ballast

Drawing #2986

REV A

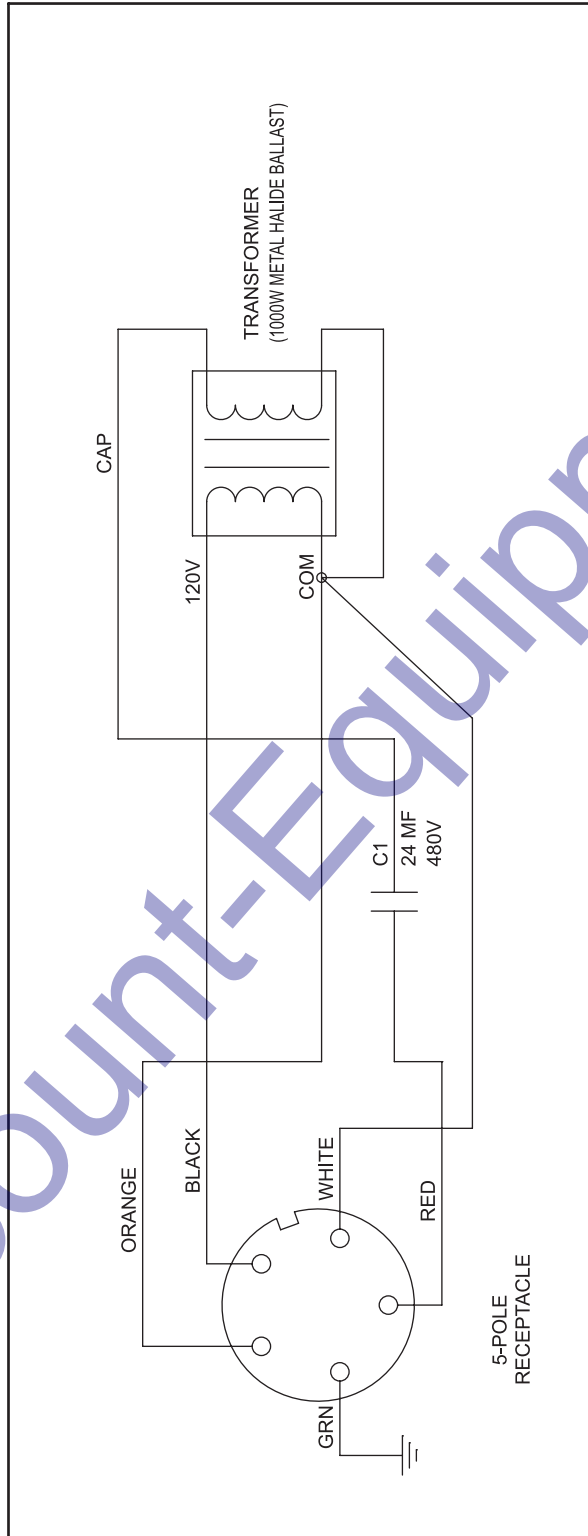

<u>COLOR</u>	<u>CIRCUIT</u>
BLACK	INPUT 120V
WHITE	INPUT COMMON
RED	LAMP HOT
ORANGE	LAMP COMMON
GREEN	GROUND



1000 HPS Ballast

Drawing #2987

REV A

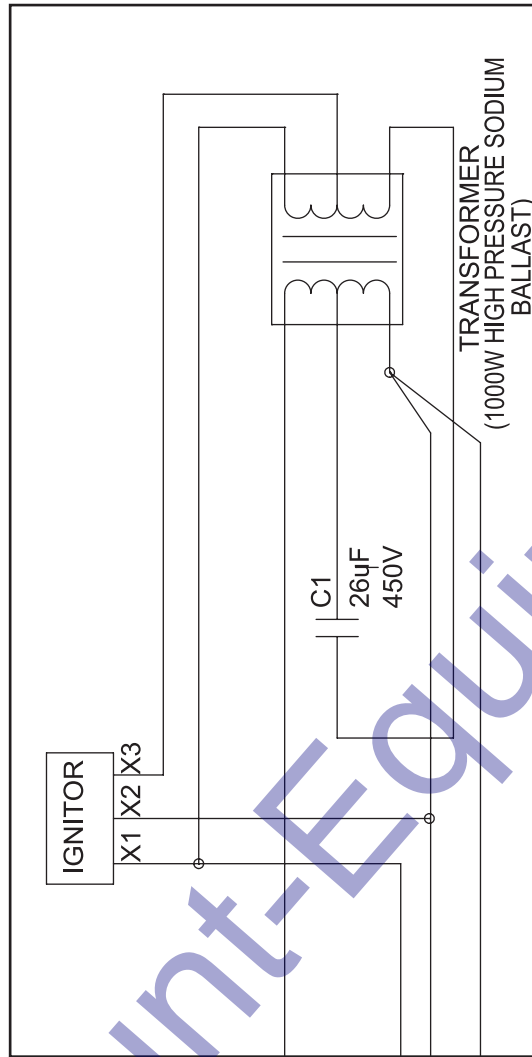

5-POLE
RECEPTACLE

COLOR	CIRCUIT
BLACK	INPUT 120V
WHITE	INPUT COMMON
RED	LAMP HOT
ORANGE	LAMP COMMON
GREEN	GROUND

California Proposition 65

Warning

The exhaust from this product contains chemicals known to the State of California to cause cancer, birth defects or other reproductive harm.

Towing Checklist

(Use at each stop)

Before Towing

- Boom hold-down latch is securely locked in place
- Towing hitch is properly secured to tow vehicle
- Safety chains (if required) are properly attached and secure (chains are crossed below hitch)
- All lights are connected and working
- Tires are properly inflated

Before Driving

- Fasten safety restraints
- Properly adjust mirrors

On The Road

- Do not exceed 60 mph / 97 km/h. Obey all local and national towing speed laws
- Check connections and tire pressure at each stop
- Slow down for hazardous conditions
- Allow extra distance for following and passing other vehicles



www.discount-equipment.com

Distributed By:

Discount-Equipment.com