

TEREX RL™4

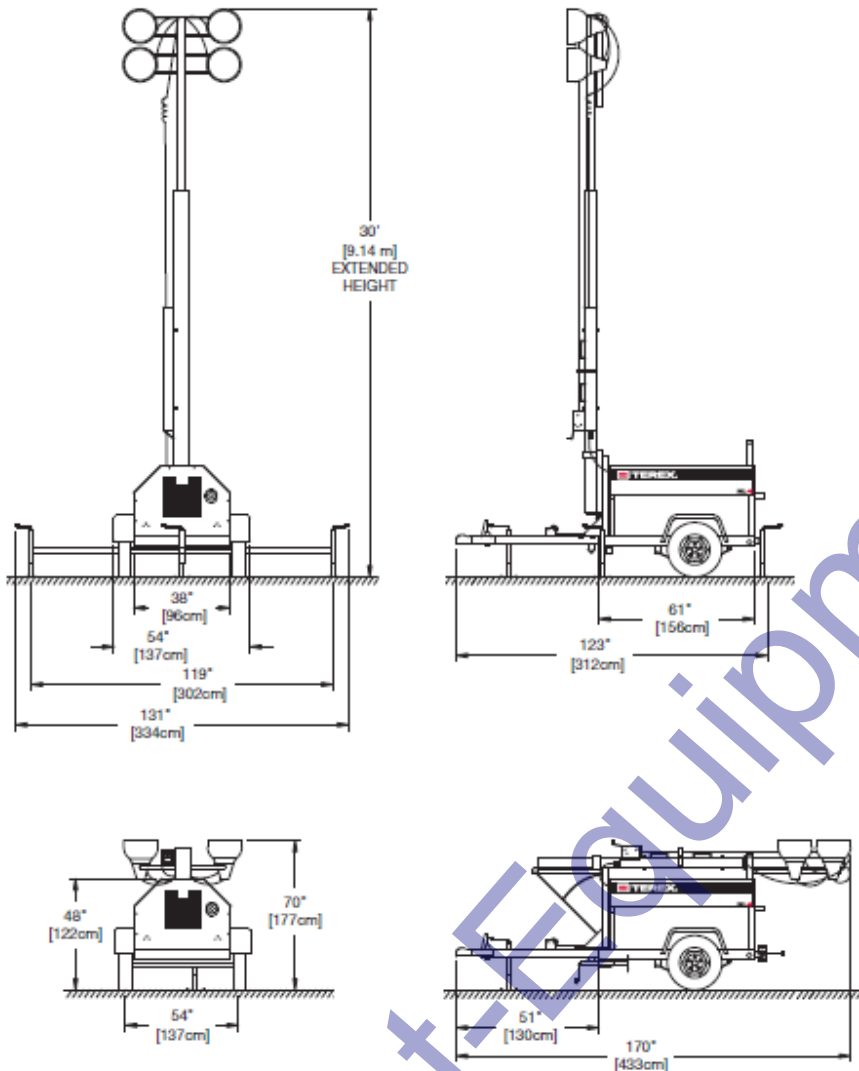

ENGINE

- Kubota® D1105 - liquid cooled, diesel engine
 - Standby – 15.4 hp @ 1800 rpm
 - Prime – 13.5 hp @ 1800 rpm
 - 3 cylinder
 - 1.123 L displacement
- Fuel consumption (prime) ~ 0.5 gph
- 60 Hz engine/generator
- Industrial engine exhaust system
- Rubber vibration dampers isolate engine/generator from frame
- Cooling system capable of operating at 120°F ambient
- Full flow oil filter, spin on type
- Fuel filter with replaceable element
- Dry type cartridge air filter
- Polyethylene fuel tank with large diameter opening
 - 30 gal. capacity
 - 60 hr. run capacity
 - 3 ½" fill port

ENGINE CONTROLS

- Galvanized control panel located inside cabinet
- Four position keyed switch – glow plugs (preheat, off, run, start)
- Hour meter
- Automatic low oil/high temperature shutdown system

GENERATOR

- Marathon Electric
 - Brushless
- 6 kW standby output
- 120/240 VAC – 20/30A
- +/-6% capacitor voltage regulation

ELECTRICAL SYSTEM AND CONTROLS

- Individual floodlight circuits with 15A breakers
- 30A start limit breaker (assures no load condition exists before starting)
- Standard individually breakered convenience outlets:
 - (1) 120 VAC 20 Amp GFCI duplex outlets (Nema 5-20R type)
 - (1) 240 VAC 30 Amp twistlock outlets (Nema L6-30R type)
- 500 CCA wet cell battery

FLOODLIGHTS

- Four light fixtures – 1000 watts each - metal halide
- Round aluminum reflector
- Tempered glass lens
- Silicone gaskets for moisture and dust protection
- Individual floodlight On/Off switches

WIRING

- All wiring is sized to the amperage draw required
- AC & DC wiring diagrams are provided in service manual

MAST

- 30' maximum extension, 3-section, tubular steel
- UHMW glide pads on all sides of mast tubes
- Standard fully galvanized mast sections
- Automatic locking system in horizontal position for travel
- 1500 lb. automatic self-braking winches
- 359° rotation with locking system
- Retractable coiled mast cord
- Galvanized mast cord protection
- Dual winch system located at ergonomic height allowing single person operation
- Equipped with single lifting eye and fork pockets

ENCLOSURE

- Steel enclosure – 14-gauge
 - UV& fade resistant, high temperature cured, white polyester powder paint
- English, English/French, or symbol operating/safety decals
- License plate holder with light
- Manual holder with operating manual

TRAILER

- Mast support – formed ¼” plate
- Removable tongue - 50” long
- Rigid formed steel chassis – 12 gauge
- Four, 2500 lb. adjustable leveling jacks – 4 point stance
- All jacks transport and lock in horizontal position for storage
- Side outriggers - 9’ 8” span
- Safety chains with s-hooks
- 2” ball hitch
- Steel fenders – 14 gauge
- DOT approved tail, side, brake, and directional lights
 - Recessed rear and side lights
- 2000 lb. leaf spring axle
- ST175/80D13 tires
- 48” axle span

WEIGHTS & DIMENSIONS

- Dry weight: 1725 lbs (783 kg)
- Mast stowed: 170 x 54 x 70 in (4.33 x 1.37 x 1.77 m)

WARRANTY

- 1 year parts and service
- Engine and generator covered under OEM warranty – consult factory for details.

CERTIFICATIONS

- CSA certified

Options

CHASSIS OPTIONS

- Blue paint with Genie Branding
- Dome light with switch, 12V
- Export racking / preparation
- Highway safety chains w/ snap hook
- Hitch, 2 ½ in Ring
- Hitch, 2 5/16 in Ball
- Hitch, Combination Ring and Ball
- Spare tire and wheel

ENGINE OPTIONS

- 6 kW, 60 Hz generator with 15.3 hp Perkins diesel
- 7 kW, 50 Hz generator with 13.6 hp Kubota diesel
- Fuel/water separator filter
- Fuel/water separator with fuel line heater

TOWER OPTIONS

- 4 horizontally mounted lights, cast aluminum square housing

COLD WEATHER OPTIONS

- 700 CCA battery
- Battery heater blanket
- Engine block heater
- Low temperature coolant mixture (-40° F)



www.discount-equipment.com