

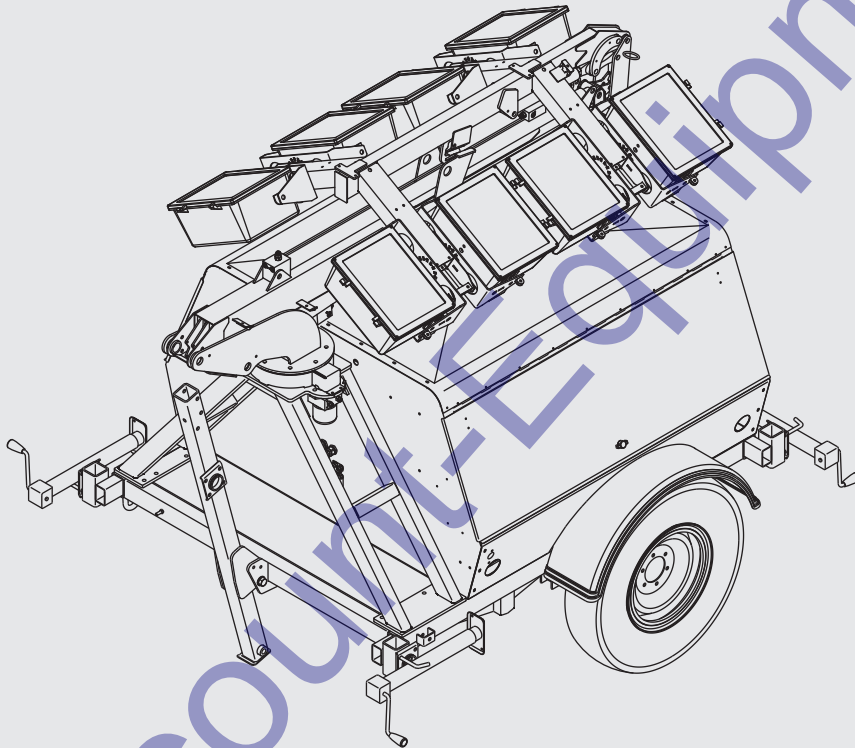

TEREX[®]

Service Manual

AL8000HT[™]



First Edition

Rev A

Part No. 116478

September 2008

Discount Equipment

Discount-Equipment.com is your online resource for commercial and industrial quality parts and equipment sales.

Locations:

Florida (West Palm Beach): [561-964-4949](tel:561-964-4949)

Outside Florida TOLL FREE: [877-690-3101](tel:877-690-3101)

Need parts? Check out our website at www.discount-equipment.com

Can't find what you need?

Click on this link: <http://www.discount-equipment.com/category/5443-parts/> and fill out the request form.

Please have the machine model and serial number available in order to help us get you the correct parts. One of our experienced staff members will get back to you with a quote for the right part that your machine needs.

We sell worldwide for the brands: Genie, Terex, JLG, MultiQuip, Mayco, Toro/Stone, Diamond Products, Magnum, Airman, Mustang, Power Blanket, Nifty Lift, Atlas Copco, Chicago Pneumatic, Allmand Brothers, Essick, Miller Spreader, Skyjack, Lull, Skytrak, Tsurumi, Husquyarna/Target, Whiteman-Concrete/Mortar, Stow-Concrete/Mortar, Baldor, Wacker, Sakai, Snorkel, Upright, Mi-T-M, Sullair, Neal, Basic, Dynapac, MBW, Weber, Bartell, Bennar Newman, Haulotte, Ditch Runner, Blaw-Knox, Himoina, Best, Buddy, Crown, Edco, Wyco, Bomag, Laymor, Terremite, Barreto, EZ Trench, Takeuchi, Basic, Bil-Jax, Curtis, Gehl, Heli, Honda, ICS/PowerGrit, Puckett, Waldon, ASV, IHI, Partner, Imer, Clipper, MMD, Koshin, Rice, Gorman Rupp, CH&E, Cat Pumps, Comet, General Pump, Giant, AMida, Coleman, NAC, Gradall, Square Shooter, Kent, Stanley, Tamco, Toku, Hatz, Kohler, Robin, Wisconsin, Northrock, Oztec, Toker TK, Rol-Air, Small Line, Wanco, Yanmar

Introduction

Important

Read, understand and obey the safety rules and operating instructions in the appropriate Operator's Manual on your machine before attempting any maintenance procedure.

Basic mechanical, hydraulic and electrical skills are required to perform most procedures. However, several procedures require specialized skills, tools, lifting equipment and a suitable workshop. In these instances, we strongly recommend that maintenance and repair be performed at an authorized Terex dealer service center.

Technical Publications

Terex has endeavored to deliver the highest degree of accuracy possible. However, continuous improvement of our products is a Terex policy. Therefore, product specifications are subject to change without notice.

Readers are encouraged to notify Terex of errors and send in suggestions for improvement. All communications will be carefully considered for future printings of this and all other manuals.



www.discount-equipment.com

Copyright © 2008 by Terex

116478 Rev A September 2008
First Edition, First Printing

 Printed on recycled paper

Printed in U.S.A.

How to Read Your Serial Number

Serial Number Legend

MANUFACTURED BY/FABRIQUE PAR:
TEREX
590 Huey Road
Rock Hill, SC 29732
USA

 **TEREX**

MODEL:
SERIAL NUMBER: XXXXXXXXXXX-999999
MODEL YEAR: 9999 **MANUFACTURE DATE:** 99/99/99

V.I.N. NUMBER:
MACHINE UNLADEN WEIGHT: 99.999 lbs / 99.999 kg

RATED GENERATOR OUTPUT: Position 41
VOLTS AC: Position 35
FREQUENCY: Position 42
PHASES: Position 43
RATED CURRENT: Position 44

ELECTRICAL SCHEMATIC: Position 3
ETL CERTIFICATION 1: Position 45
ETL CERTIFICATION 2: Position 46

P/N 77172

3057837

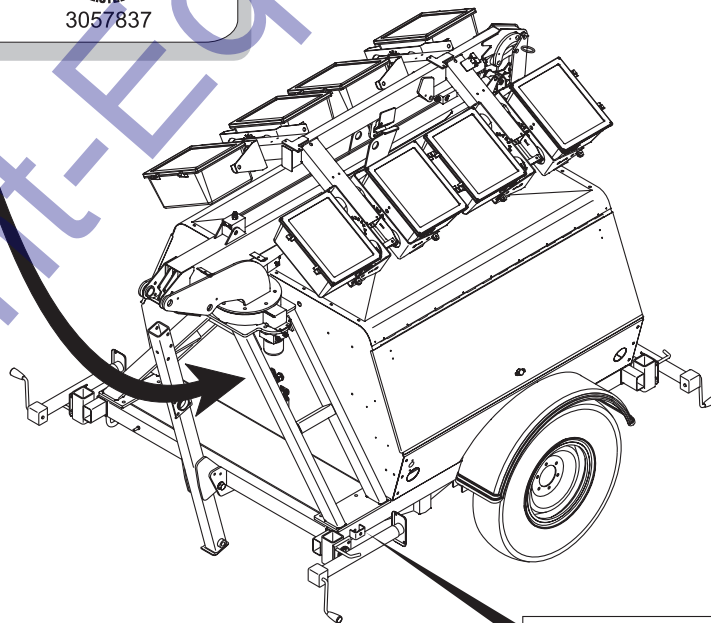

AL8XXXXX
Serial number is stamped into frame.

Safety Rules



Danger

Failure to obey the instructions and safety rules in this manual and the *Terex AL8000HT Operator's Manual* on your machine will result in death or serious injury.

Many of the hazards identified in the operator's manual are also safety hazards when maintenance and repair procedures are performed.

Do Not Perform Maintenance Unless:

- You are trained and qualified to perform maintenance on this machine.
- You read, understand and obey:
 - manufacturer's instructions and safety rules
 - employer's safety rules and worksite regulations
 - applicable governmental regulations
- You have the appropriate tools, lifting equipment and a suitable workshop.



Personal Safety

Any person working on or around a machine must be aware of all known safety hazards. Personal safety and the continued safe operation of the machine should be your top priority.



Read each procedure thoroughly. This manual and the decals on the machine, use signal words to identify the following:



Safety alert symbol—used to alert personnel to potential personal injury hazards. Obey all safety messages that follow this symbol to avoid possible injury or death.

▲ DANGER

Indicates an imminently hazardous situation which, if not avoided, will result in death or serious injury.

▲ WARNING

Indicates a potentially hazardous situation which, if not avoided, could result in death or serious injury.

▲ CAUTION

Indicates a potentially hazardous situation which, if not avoided, may cause minor or moderate injury.

NOTICE

Indicates a potentially hazardous situation which, if not avoided, may result in property damage.



Be sure to wear protective eye wear and other protective clothing if the situation warrants it.



Be aware of potential crushing hazards such as moving parts, free swinging or unsecured components when lifting or placing loads. Always wear approved steel-toed shoes.

Workplace Safety



Be sure to keep sparks, flames and lighted tobacco away from flammable and combustible materials like battery gases and engine fuels. Always have an approved fire extinguisher within easy reach.



Be sure that all tools and working areas are properly maintained and ready for use. Keep work surfaces clean and free of debris that could get into machine components and cause damage.



Be sure any forklift, overhead crane or other lifting or supporting device is fully capable of supporting and stabilizing the weight to be lifted. Use only chains or straps that are in good condition and of ample capacity.



Be sure that fasteners intended for one time use (i.e., cotter pins and self-locking nuts) are not reused. These components may fail if they are used a second time.



Be sure to properly dispose of old oil or other fluids. Use an approved container. Please be environmentally safe.



Be sure that your workshop or work area is properly ventilated and well lit.

Table of Contents

Introduction

Important Information	<i>ii</i>
How to Read Your Serial Number	<i>iii</i>
Parts Stocking List	<i>x</i>
How to Order Parts	<i>xi</i>
Service Parts Fax Order Form	<i>xii</i>

Section 1

Safety Rules

General Safety Rules	<i>iv</i>
----------------------------	-----------

Section 2

Rev Specifications

A	Machine Specifications	2 - 1
	Performance Specifications	2 - 1
	Hydraulic Oil Specifications	2 - 2
	Hydraulic Component Specifications	2 - 2
	Manifold Component Specifications	2 - 3
	Kubota D1105-E Engine	2 - 4
	Kubota V1505-E Engine	2 - 5
	Isuzu 4LE1 Engine	2 - 6
	Generator Specifications	2 - 7
	Hydraulic Hose and Fitting Torque Specifications	2 - 8
	SAE and Metric Fasteners Torque Charts	2 - 9
	Genset Torque Specifications	2 - 10

Section 3

Rev Scheduled Maintenance Procedures

	Introduction	3 - 1
	Pre-delivery Preparation Report	3 - 3
	Maintenance Inspection Report	3 - 5
A	Checklist A Procedures	
A-1	Inspect the Manuals and Decals	3 - 7
A-2	Perform Pre-operation Inspection	3 - 8
A-3	Perform Function Tests	3 - 8

TABLE OF CONTENTS

	A-4	Perform Engine Maintenance - Isuzu Models	3 - 9
<hr/>			
Section 3	Rev	Scheduled Maintenance Procedures, continued	
	A-5	Perform Generator Maintenance	3 - 9
	A-6	Perform Axle Maintenance	3 - 10
	A-7	Perform 30 Day Service	3 - 10
	A-8	Perform Engine Maintenance	3 - 11
	A-9	Perform Hitch Maintenance	3 - 11
	A-10	Grease the Turntable Rotation Bearing and Rotate Gear	3 - 12
	A-11	Perform Engine Maintenance - Kubota Models	3 - 13
	A-12	Perform Engine Maintenance - Kubota Models	3 - 13
	A	Checklist B Procedures	
	B-1	Inspect the Battery	3 - 14
	B-2	Inspect the Electrical Wiring	3 - 14
	B-3	Inspect the Tires and Wheels (including lug nut torque)	3 - 15
	B-4	Perform Hydraulic Oil Analysis	3 - 15
	B-5	Perform Engine Maintenance - Isuzu Models	3 - 16
	B-6	Perform Generator Maintenance	3 - 16
	B-7	Perform Hitch Maintenance	3 - 17
	B-8	Perform Engine Maintenance - Kubota Models	3 - 17
	B-9	Perform Axle Maintenance	3 - 17
	A	Checklist C Procedures	
	C-1	Inspect the Tower Extend/Retract Cables and Pulleys	3 - 19
	C-2	Perform Engine Maintenance	3 - 19
	C-3	Perform Axle Maintenance	3 - 20
	C-4	Perform Engine Maintenance - Isuzu Models	3 - 20
	C-5	Perform Engine Maintenance - Kubota Models	3 - 21
	A	Checklist D Procedures	
	D-1	Perform Engine Maintenance - Kubota Models	3 - 22
	D-2	Check the Tower Rotation Bearing Bolts	3 - 22
	D-3	Replace the Hydraulic Return Filter	3 - 23
	D-4	Perform Engine Maintenance - Isuzu Models	3 - 24

TABLE OF CONTENTS

	D-5	Perform Engine Maintenance - Isuzu Models	3 - 24
	D-6	Perform Engine Maintenance	3 - 25
<hr/>			
Section 3	Rev	Scheduled Maintenance Procedures, continued	
	D-7	Perform Generator Maintenance	3 - 25
	D-8	Perform Tongue Jack and Outrigger Jack Maintenance	3 - 26
	D-9	Perform Axle Maintenance	3 - 26
	E-1	Test or Replace the Hydraulic Oil	3 - 27
	E-2	Perform Engine Maintenance - Kubota Models	3 - 28
	E-3	Perform Engine Maintenance - Kubota Models	3 - 29
	E-4	Perform Generator Maintenance	3 - 29
	E-5	Perform Generator Maintenance	3 - 30
<hr/>			
Section 4	Rev	Repair Procedures	
		Introduction	4 - 1
	A	Lighting	
		1-1 Lighting	4 - 2
	A	Light Bar Components	
		2-1 Light Bar	4 - 4
		2-2 Light Bar Lift Cylinder	4 - 5
	A	Tower Components	
		3-1 Plastic Cable Track	4 - 7
		3-2 Tower Assembly	4 - 7
		3-3 Tower Lift Cylinder	4 - 10
		3-4 Tower Extension Cylinder	4 - 11
		3-5 Tower Rotation Motor	4 - 12
	A	Kubota D1105-E/V1505-E Engine	
		4-1 Timing Adjustment	4 - 13
		4-2 Glow Plugs	4 - 13
		4-3 Coolant Temperature and Oil Pressure Switches	4 - 13
	A	Isuzu 4LE1 Engine	
		5-1 Timing Adjustment	4 - 14

TABLE OF CONTENTS

	5-2	Glow Plugs	4 - 14
	5-3	Coolant Temperature and Oil Pressure Switches	4 - 14
<hr/>			
Section 4	Rev	Repair Procedures, continued	
	A	Generator	
	6-1	Generator	4 - 15
	A	Chassis Components	
	7-1	Ground Controls	4 - 19
	7-2	Light Ballast	4 - 20
	7-3	Fuel Tank	4 - 21
	8-1	Function Manifold Components	4 - 23
	8-2	Valve Adjustments - Function Manifold	4 - 24
<hr/>			
Section 5	Rev	Troubleshooting	
		Introduction	5 - 1
	A	Troubleshooting Guide	5 - 2
	A	Light Fixture Troubleshooting	5 - 5
<hr/>			
Section 6	Rev	Schematics	
	A	Introduction	6 - 1
	A	Electrical Symbols Legend	6 - 2
	A	Hydraulic Symbols Legend	6 - 3
	A	Electrical Schematic - Machine Functions	6 - 4
	A	DC Electrical Schematic - Control Box and Engine - Isuzu Models	6 - 5
	A	DC Electrical Schematic - Control Box and Engine - Kubota Models	6 - 6
	A	DC Electrical Schematic - Control Box and Engine - with Autostart Option	6 - 7
	A	AC Electrical Schematic - Standard Models with 4 Lights	6 - 8
	A	AC Electrical Schematic - Standard Models with 6 Lights	6 - 9
	A	AC Electrical Schematic - Standard Models with 8 Lights	6 - 10
	A	AC Electrical Schematic - Autostart Models with 4 Lights	6 - 11
	A	AC Electrical Schematic - Autostart Models with 6 Lights	6 - 12
	A	AC Electrical Schematic - Autostart Models with 8 Lights	6 - 13
	A	Receptacle Wiring Diagrams	6 - 14
	A	Hydraulic Schematic	6 - 15



Parts Stocking List

Required Parts

The following parts are required to perform maintenance procedures as outlined in the *TEREX AL8000HT Parts and Service Manual*.

Description	Part No.
Kubota Models	
Oil Filter	866050
Air Filter	866127
Fuel Filter	839200
V-belt	839209
Isuzu Models	
Oil Filter	868075
Air Filter	834460
Fuel Filter	868137
V-belt	868067

Manuals

TEREX Corporation offers the following manuals for these models:

Title	Part No.
TEREX AL8000HT Operator's Manual, First Edition	114426
TEREX AL8000HT Part's Manual, First Edition	116447
TEREX AL8000HT Service Manual, First Edition	116478
Newage Generator Manual	830001
Leroy Somer Manual	116118
Isuzu Engine Manual	116133
Kubota Engine Manual	893020
Axis Manual	116117
Marathon Manual	116188

How To Order Parts

Please be prepared with the following information when ordering replacement parts for your TEREX product:

- Machine model number
- Machine serial number
- Terex part number
- Part description and quantity
- Purchase order number
- "Ship to" address
- Desired method of shipment
- Name and telephone number of the authorized TEREX Distributor in your area



www.discount-equipment.com

Machine Information

Model

Serial Number

Date of Purchase

Authorized TEREX Distributor

Phone Number

Discount Equipment

Discount-Equipment.com is your online resource for commercial and industrial quality parts and equipment sales.

Locations:

Florida (West Palm Beach): [561-964-4949](tel:561-964-4949)

Outside Florida TOLL FREE: [877-690-3101](tel:877-690-3101)

Need parts? Check out our website at www.discount-equipment.com

Can't find what you need?

Click on this link: <http://www.discount-equipment.com/category/5443-parts/> and fill out the request form.

Please have the machine model and serial number available in order to help us get you the correct parts. One of our experienced staff members will get back to you with a quote for the right part that your machine needs.

We sell worldwide for the brands: Genie, Terex, JLG, MultiQuip, Mayco, Toro/Stone, Diamond Products, Magnum, Airman, Mustang, Power Blanket, Nifty Lift, Atlas Copco, Chicago Pneumatic, Allmand Brothers, Essick, Miller Spreader, Skyjack, Lull, Skytrak, Tsurumi, Husquyarna/Target, Whiteman-Concrete/Mortar, Stow-Concrete/Mortar, Baldor, Wacker, Sakai, Snorkel, Upright, Mi-T-M, Sullair, Neal, Basic, Dynapac, MBW, Weber, Bartell, Bennar Newman, Haulotte, Ditch Runner, Blaw-Knox, Himoina, Best, Buddy, Crown, Edco, Wyco, Bomag, Laymor, Terremite, Barreto, EZ Trench, Takeuchi, Basic, Bil-Jax, Curtis, Gehl, Heli, Honda, ICS/PowerGrit, Puckett, Waldon, ASV, IHI, Partner, Imer, Clipper, MMD, Koshin, Rice, Gorman Rupp, CH&E, Cat Pumps, Comet, General Pump, Giant, AMida, Coleman, NAC, Gradall, Square Shooter, Kent, Stanley, Tamco, Toku, Hatz, Kohler, Robin, Wisconsin, Northrock, Oztec, Toker TK, Rol-Air, Small Line, Wanco, Yanmar

**TEREX**

Specifications

REV A

Machine Specifications

Lights

Type: BT-37 Metal Halide, 1000 watt

Total lighting wattage

4 lights 4000 watts
8 lights 8000 watts

Axle

Axle load capacity, maximum 4200 lbs
1905 kg

Fluid capacities

Hydraulic tank capacity 1.4 gallons
5.3 litersHydraulic system capacity 2 gallons
(including tank) 7.6 litersSingle fuel tank 30 gallons
114 litersDual fuel tanks 60 gallons
227 liters

Tires and wheels (U.S. models)

Tire size ST205/75R15
Load range CLug nut torque, dry 80 ft-lbs
108 NmTire pressure, maximum (cold) 50 psi
3.4 bar

Tires and wheels (Australia models)

Tire size 7.5R16 C 112/110L

Lug nut torque, dry 80 ft-lbs
108 NmTire pressure, maximum (cold) 75 psi
5.2 bar

Performance Specifications

Tongue weight, maximum 350 lbs
159 kg

Run time, full load

Kubota D1105 (8kW) @ .82 Gallons per hour

Single full fuel tank 36.5 hours

Dual full fuel tanks 73 hours

Run time, full load

Kubota V1505 (12kW) @ 1.1 Gallons per hour

Single full fuel tank 27.25 hours

Dual full fuel tanks 54.5 hours

Run time, full load

Isuzu 4LE1 (20kW) @ 1.8 Gallons per hour

Single full fuel tank 16.5 hours

Dual full fuel tanks 33 hours

Towing speed, maximum

62 mph
100 km/h

Function speeds

Boom up 12 to 24 seconds

Boom down 12 to 21 seconds

Boom extend 17 to 37 seconds

Boom retract 13 to 27 seconds

Light bar up 18 to 30 seconds

Light bar down 14 to 24 seconds

Tower rotate, 359° 31 to 68 seconds

For operational specifications, refer to the Operator's Manual.

Continuous improvement of our products is a Terex policy. Product specifications are subject to change without notice.

SPECIFICATIONS

REV A

Hydraulic Oil Specifications

Hydraulic Oil Specifications

Hydraulic oil type	Chevron Rando HD Premium MV
Viscosity grade	Multi-viscosity
Viscosity index	200
Cleanliness level, minimum	15/13
Water content, maximum	200 ppm

Chevron Rykon MV oil is fully compatible and mixable with Shell Donax TG (Dexron III) oils.

Genie specifications require hydraulic oils which are designed to give maximum protection to hydraulic systems, have the ability to perform over a wide temperature range, and the viscosity index should exceed 140. They should provide excellent antiwear, oxidation, corrosion inhibition, seal conditioning, and foam and aeration suppression properties.

Optional fluids

Biodegradable	Petro Canada Environ MV46 Statoil Hydra Way Bio Pa 32 BP Biohyd SE-S
Fire resistant	UCON Hydrolube HP-5046 Quintolubric 822
Mineral based	Shell Tellus T32 Shell Tellus T46 Chevron Aviation A

NOTICE Continued use of Chevron Aviation A hydraulic fluid when ambient temperatures are consistently above 32°F / 0°C may result in component damage.

Note: Use Chevron Aviation A hydraulic fluid when ambient temperatures are consistently below 0°F / -18°C.

Note: Use Shell Tellus T46 hydraulic oil when oil temperatures consistently exceed 205°F / 96°C.

Note: Terex specifications require additional equipment and special installation instructions for the approved optional fluids. Consult the Terex Service Department before use.

Hydraulic Component Specifications

Function pump

Type:	Fixed displacement gear pump
Displacement per revolution	0.056 cu in 0.92 cc
Flow rate @ 3200 psi	0.6 gpm 2.27 L/min
System relief pressure	3200 psi 220.6 bar

Function manifold

Light bar up/down flow regulator	0.2 gpm 0.76 L/min
Tower rotate relief valve pressure	1200 psi 82.7 bar

Hydraulic filter

Hydraulic tank return filter	Beta 10 ≥ 200 with 25 psi / 1.7 bar bypass
------------------------------	---

Continuous improvement of our products is a Terex policy. Product specifications are subject to change without notice.

REV A

SPECIFICATIONS

Manifold Component Specifications

Plug torque

SAE No. 2	36 in-lbs / 4 Nm
SAE No. 4	10 ft-lbs / 13 Nm
SAE No. 6	14 ft-lbs / 19 Nm
SAE No. 8	38 ft-lbs / 51 Nm
SAE No. 10	41 ft-lbs / 55 Nm
SAE No. 12	56 ft-lbs / 76 Nm

Valve Coil Resistance

Note: The following coil resistance specifications are at an ambient temperature of 68°F / 20°C. As valve coil resistance is sensitive to changes in air temperature, the coil resistance will typically increase or decrease by 4% for each 18°F / 20°C that your air temperature increases or decreases from 68°F / 20°C.

Valve coil specifications

3 position 4 way solenoid valve, 10V DC (schematic items B, C, E and G)	6Ω
---	----

Machine Torque Specifications

Tower rotation assembly

Rotate bearing mounting bolts, lubricated	
1/2 -13 SHC bolts	95 ft-lbs 129 Nm
5/8 -11 SHC bolts	195 ft-lbs 264 Nm
Rotation motor mounting bolts, dry	75 ft-lbs 102 Nm
1/2 -13, GR 5	
Rotation motor mounting bolts, lubricated	57 ft-lbs 77 Nm
1/2 -13, GR 5	

Generator

Generator case to engine bell housing fasteners	25 ft-lbs 34 Nm
Generator vibration isolator fasteners	75 ft-lbs 102 Nm
Flex plate to flywheel	25 ft-lbs 34 Nm

Continuous improvement of our products is a Terex policy. Product specifications are subject to change without notice.

SPECIFICATIONS

REV A

Kubota D1105-E Engine

Displacement	68.53 cu in 1.12 liters
Number of cylinders	3
Bore and stroke	3.07 x 3.09 inches 78 x 78.4 mm
Horsepower, continuous	13.6 @ 1800 rpm 10.1 kW
Firing order	1 - 2 - 3
Compression ratio	23:1
Compression pressure	412 to 469 psi 28.4 to 32.3 bar
Engine speed	1800 rpm
Governor	centrifugal mechanical
Valve clearance, cold	0.0057 to 0.0072 in 0.145 to 0.185 mm

Engine coolant	
Capacity	3.27 quarts 3.1 liters

Lubrication system

Oil pressure	28 to 64 psi 1.93 to 4.41 bar
Oil capacity (including filter)	5.4 quarts 5.1 liters
Oil pressure switch (engine shutoff pressure)	7 psi

Oil viscosity requirements

Units ship with 10W-30.
Extreme operating temperatures may require the use of alternative engine oils. For oil requirements, refer to the Engine Operator Handbook on your machine.

Injection system

Injection pump make	Bosch MD mini
Injection timing	19° BTDC
Injection pump pressure	1991 psi 137 bar

Fuel requirement

For fuel requirements, refer to the engine Operator's Manual on your machine.

Battery

Type	12V DC
Group	27TM
Quantity	1
Cold cranking ampere	500
Reserve capacity @ 25A rate	105 minutes

Alternator

Output	40A, 12V DC
Fan belt deflection	1/4 to 3/8 inch 7 to 9 mm

Continuous improvement of our products is a Terex policy. Product specifications are subject to change without notice.



REV A

SPECIFICATIONS

Kubota V1505-E Engine

Displacement	91.41 cu in 1.5 liters
Number of cylinders	4
Bore and stroke	3.07 x 3.09 inches 78 x 78.4 mm
Horsepower, continuous	17.9 @ 1800 rpm 13.4 kW
Firing order	1 - 3 - 4 - 2
Compression ratio	22:1
Compression pressure	412 to 469 psi 28.4 to 32.3 bar
Engine speed	1800 rpm
Governor	centrifugal mechanical
Valve clearance, cold	0.0057 to 0.0072 in 0.145 to 0.185 mm

Engine coolant	
Capacity	4.23 quarts 4 liters

Lubrication system

Oil pressure	28 to 64 psi 1.93 to 4.41 bar
Oil capacity (including filter)	7.08 quarts 6.7 liters
Oil pressure switch (engine shutoff pressure)	7 psi

Oil viscosity requirements

Units ship with 10W-30.
Extreme operating temperatures may require the use of alternative engine oils. For oil requirements, refer to the Engine Operator Handbook on your machine.

Injection system

Injection pump make	Bosch MD mini
Injection timing	19° BTDC
Injection pump pressure	1991 psi 137 bar

Fuel requirement

For fuel requirements, refer to the engine Operator's Manual on your machine.

Battery

Type	12V DC
Group	27TM
Quantity	1
Cold cranking ampere	630
Reserve capacity @ 25A rate	105 minutes

Alternator

Output	30A, 12V DC
Fan belt deflection	1/4 to 3/8 inch 7 to 9 mm

SPECIFICATIONS

REV A

Isuzu 4LE1 Engine

Displacement	133 cu in 2.179 liters
---------------------	---------------------------

Number of cylinders	4
----------------------------	---

Bore and stroke	3.35 x 3.78 inches 85 x 96 mm
------------------------	----------------------------------

Horsepower, continuous	31.4 @ 1800 rpm 23.4kW
-------------------------------	---------------------------

Firing order	1 - 3 - 4 - 2
---------------------	---------------

Compression ratio	21.5:1
--------------------------	--------

Engine speed	1800 rpm
---------------------	----------

Governor	variable speed, mechanical
-----------------	----------------------------

Valve clearance, cold

Intake	0.0157 in 0.4 mm
--------	---------------------

Exhaust	0.0157 in 0.4 mm
---------	---------------------

Lubrication system

Oil pressure (hot @ 1800 rpm)	64 psi 4.4 bar
-------------------------------	-------------------

Oil capacity (including filter)	7.08 quarts 6.7 liters
---------------------------------	---------------------------

Oil pressure switch (engine shut-off pressure)	14 psi 0.96 bar
--	--------------------

Oil viscosity requirements

Units ship with 10W-30.
Extreme operating temperatures may require the use of alternative engine oils. For oil requirements, refer to the Engine Operating Instructions on your machine.

Engine coolant

Capacity	4 quarts 3.8 liters
----------	------------------------

Coolant temperature switch (engine shut-off temperature)	221° ±7°F 105° ±4°C
--	------------------------

Injection system

Injection pump make	Bosch, PFR ype
---------------------	----------------

Injection timing	16° BTDC
------------------	----------

Injection pump pressure	1920 psi 132.8 bar
-------------------------	-----------------------

Fuel requirement

For fuel requirements, refer to the engine Operator's Manual on your machine.

Battery

Type	12V DC
------	--------

Group	27TM
-------	------

Quantity	1
----------	---

Cold cranking ampere	630
----------------------	-----

Reserve capacity @ 25A rate	105 minutes
-----------------------------	-------------

Alternator

Output	35A, 12V DC
--------	-------------

Fan belt deflection	1/4 to 3/8 inch 7 to 9 mm
---------------------	------------------------------

Continuous improvement of our products is a Terex policy. Product specifications are subject to change without notice.



REV A

SPECIFICATIONS

Leroy Somer LSA37M7 Generator

Generator speed @ full load	60 Hz	1800 rpm
Temperature, ambient maximum	104°F 40°C	
Power	8 kW	
Capacitor (disconnected)	100 µF @ 240V	

Marathon 201CSA5412 Generator

Generator rpm @ full load	60 Hz	1800 rpm
Temperature, ambient maximum	104°F 40°C	
Power	8 kW	

Newage BCI164D1J195A Generator

Generator rpm @ full load	60 Hz	1800 rpm
Temperature, ambient maximum	104°F 40°C	
Power	12 kW	

Newage BCI184E1J203A Generator

Generator rpm @ full load	60 Hz	1800 rpm
Temperature, ambient maximum	104°F 40°C	
Power	20 kW	

Continuous improvement of our products is a Terex policy. Product specifications are subject to change without notice.

SPECIFICATIONS

REV A

Hydraulic Hose and Fitting Torque Specifications

Your machine is equipped with Parker Seal-Lok® fittings and hose ends. Genie specifications require that fittings and hose ends be torqued to specification when they are removed and installed or when new hoses or fittings are installed.

SAE O-ring Boss Port

(tube fitting - installed into Aluminum)

SAE Dash size	Torque
-4	11 ft-lbs / 14.9 Nm
-6	23 ft-lbs / 31.2 Nm
-8	40 ft-lbs / 54.2 Nm
-10	69 ft-lbs / 93.6 Nm
-12	93 ft-lbs / 126.1 Nm
-16	139 ft-lbs / 188.5 Nm
-20	172 ft-lbs / 233.2 Nm
-24	208 ft-lbs / 282 Nm

SAE O-ring Boss Port

(tube fitting - installed into Steel)

SAE Dash size	Torque
-4	16 ft-lbs / 21.7 Nm
-6	35 ft-lbs / 47.5 Nm
-8	60 ft-lbs / 81.3 Nm
-10	105 ft-lbs / 142.4 Nm
-12	140 ft-lbs / 190 Nm
-16	210 ft-lbs / 284.7 Nm
-20	260 ft-lbs / 352.5 Nm
-24	315 ft-lbs / 427.1 Nm

Seal-Lok® fittings

- 1 Replace the O-ring. The O-ring must be replaced anytime the seal has been broken. The O-ring cannot be re-used if the fitting or hose end has been tightened beyond finger tight.

Note: The O-rings used in the Parker Seal Lok® fittings and hose ends are custom-size O-rings. They are not standard SAE size O-rings. They are available in the O-ring field service kit (Genie part number 49612).

- 2 Lubricate the O-ring before installation.
- 3 Be sure that the face seal O-ring is seated and retained properly.
- 4 Position the tube and nut squarely on the face seal end of the fitting and tighten the nut finger tight.
- 5 Tighten the nut or fitting to the appropriate torque per given size as shown in the table.
- 6 Operate all machine functions and inspect the hoses and fittings and related components to confirm that there are no leaks.

Seal-Lok® Fittings

(hose end)

SAE Dash size	Torque
-4	18 ft-lbs / 25 Nm
-6	30 ft-lbs / 40 Nm
-8	40 ft-lbs / 55 Nm
-10	60 ft-lbs / 80 Nm
-12	85 ft-lbs / 115 Nm
-16	110 ft-lbs / 150 Nm
-20	140 ft-lbs / 190 Nm
-24	180 ft-lbs / 245 Nm



REV A

SPECIFICATIONS

SAE FASTENER TORQUE CHART											
• This chart is to be used as a guide only unless noted elsewhere in this manual •											
SIZE	THREAD	Grade 5				Grade 8				A574 High Strength Black Oxide Bolts	
		LUBED		DRY		LUBED		DRY		LUBED	
		in-lbs	Nm	in-lbs	Nm	in-lbs	Nm	in-lbs	Nm	in-lbs	Nm
1/4	20	80	9	100	11.3	110	12.4	140	15.8	130	14.7
	28	90	10.1	120	13.5	120	13.5	160	18	140	15.8
		LUBED		DRY		LUBED		DRY		LUBED	
		ft-lbs	Nm	ft-lbs	Nm	ft-lbs	Nm	ft-lbs	Nm	ft-lbs	Nm
5/16	18	13	17.6	17	23	18	24	25	33.9	21	28.4
	24	14	19	19	25.7	20	27.1	27	36.6	24	32.5
3/8	16	23	31.2	31	42	33	44.7	44	59.6	38	51.5
	24	26	35.2	35	47.4	37	50.1	49	66.4	43	58.3
7/16	14	37	50.1	49	66.4	50	67.8	70	94.7	61	82.7
	20	41	55.5	55	74.5	60	81.3	80	108.4	68	92.1
1/2	13	57	77.3	75	101.6	80	108.4	110	149	93	126
	20	64	86.7	85	115	90	122	120	162	105	142
9/16	12	80	108.4	110	149	120	162	150	203	130	176
	18	90	122	120	162	130	176	170	230	140	189
5/8	11	110	149	150	203	160	217	210	284	180	244
	18	130	176	170	230	180	244	240	325	200	271
3/4	10	200	271	270	366	280	379	380	515	320	433
	16	220	298	300	406	310	420	420	569	350	474
7/8	9	320	433	430	583	450	610	610	827	510	691
	14	350	474	470	637	500	678	670	908	560	759
1	8	480	650	640	867	680	922	910	1233	770	1044
	12	530	718	710	962	750	1016	990	1342	840	1139
1 1/8	7	590	800	790	1071	970	1315	1290	1749	1090	1477
	12	670	908	890	1206	1080	1464	1440	1952	1220	1654
1 1/4	7	840	1138	1120	1518	1360	1844	1820	2467	1530	2074
	12	930	1260	1240	1681	1510	2047	2010	2725	1700	2304
1 1/2	6	1460	1979	1950	2643	2370	3213	3160	4284	2670	3620
	12	1640	2223	2190	2969	2670	3620	3560	4826	3000	4067

METRIC FASTENER TORQUE CHART																
• This chart is to be used as a guide only unless noted elsewhere in this manual •																
Size (mm)	Class 4.6				Class 8.8				Class 10.9				Class 12.9			
	LUBED		DRY		LUBED		DRY		LUBED		DRY		LUBED		DRY	
	in-lbs	Nm	in-lbs	Nm	in-lbs	Nm	in-lbs	Nm	in-lbs	Nm	in-lbs	Nm	in-lbs	Nm	in-lbs	Nm
5	16	1.8	21	2.4	41	4.63	54	6.18	58	6.63	78	8.84	68	7.75	91	10.3
6	19	3.05	36	4.07	69	7.87	93	10.5	100	11.3	132	15	116	13.2	155	17.6
7	45	5.12	60	6.83	116	13.2	155	17.6	167	18.9	223	25.2	1.95	22.1	260	29.4
	LUBED		DRY		LUBED		DRY		LUBED		DRY		LUBED		DRY	
	ft-lbs	Nm	ft-lbs	Nm	ft-lbs	Nm	ft-lbs	Nm	ft-lbs	Nm	ft-lbs	Nm	ft-lbs	Nm	ft-lbs	Nm
8	5.4	7.41	7.2	9.88	14	19.1	18.8	25.5	20.1	27.3	26.9	36.5	23.6	32	31.4	42.6
10	10.8	14.7	14.4	19.6	27.9	37.8	37.2	50.5	39.9	54.1	53.2	72.2	46.7	63.3	62.3	84.4
12	18.9	25.6	25.1	34.1	48.6	66	64.9	88	69.7	94.5	92.2	125	81	110	108	147
14	30.1	40.8	40	54.3	77.4	105	103	140	110	150	147	200	129	175	172	234
16	46.9	63.6	62.5	84.8	125	170	166	226	173	235	230	313	202	274	269	365
18	64.5	87.5	86.2	117	171	233	229	311	238	323	317	430	278	377	371	503
20	91	124	121	165	243	330	325	441	337	458	450	610	394	535	525	713
22	124	169	166	225	331	450	442	600	458	622	612	830	536	727	715	970
24	157	214	210	285	420	570	562	762	583	791	778	1055	682	925	909	1233

GENSET TORQUE SPECIFICATIONS

Generator	FT*LB
Flex Plate to Flywheel	25
Generator Case to Bellhousing	25
Genset Isolators	75



Scheduled Maintenance Procedures



Observe and Obey:

- ☑ Maintenance inspections shall be completed by a person trained and qualified on the maintenance of this machine.
- ☑ Scheduled maintenance inspections shall be completed daily, quarterly, semi-annually, annually and every 2 years as specified on the *Maintenance Inspection Report*.

AWARNING Failure to perform each procedure as presented and scheduled could result in death, serious injury or substantial damage.

- ☑ Immediately tag and remove from service a damaged or malfunctioning machine.
- ☑ Repair any machine damage or malfunction before operating the machine.
- ☑ Use only Terex approved replacement parts.
- ☑ Machines that have been out of service for a period longer than 3 months must complete the quarterly inspection.
- ☑ Unless otherwise specified, perform each maintenance procedure with the machine in the following configuration:
 - Machine parked on a firm, level surface
 - Key switch in the off position (manual start models)
 - Toggle switch in the off position (automatic start models)
 - Mast in the stowed position
 - Light switches in the off position
 - Wheels chocked

About This Section

This section contains detailed procedures for each scheduled maintenance inspection.

Each procedure includes a description, safety warnings and step-by-step instructions.

Symbols Legend



Safety alert symbol—used to alert personnel to potential personal injury hazards. Obey all safety messages that follow this symbol to avoid possible injury or death.



Indicates an imminently hazardous situation which, if not avoided, will result in death or serious injury.



Indicates a potentially hazardous situation which, if not avoided, could result in death or serious injury.



Indicates a potentially hazardous situation which, if not avoided, may cause minor or moderate injury.



Indicates a potentially hazardous situation which, if not avoided, may result in property damage.

⦿ Indicates that a specific result is expected after performing a series of steps.

⊗ Indicates that an incorrect result has occurred after performing a series of steps.

SCHEDULED MAINTENANCE PROCEDURES

Maintenance Symbols Legend

The following symbols have been used in this manual to help communicate the intent of the instructions. When one or more of the symbols appear at the beginning of a maintenance procedure, it conveys the meaning below.



Indicates that tools will be required to perform this procedure.



Indicates that new parts will be required to perform this procedure.



Indicates that a cold engine will be required to perform this procedure.



Indicates that a warm engine will be required to perform this procedure.



Indicates that dealer service will be required to perform this procedure.

Pre-delivery Preparation Report

The pre-delivery preparation report contains checklists for each type of scheduled inspection.

Make copies of the *Pre-delivery Preparation* report to use for each inspection. Store completed forms as required.

Maintenance Schedule

There are five types of maintenance inspections that must be performed according to a schedule—daily, quarterly, semi-annually, annual and two year. The *Scheduled Maintenance Procedures Section* and the *Maintenance Inspection Report* have been divided into five subsections—A, B, C, D and E. Use the following chart to determine which group(s) of procedures are required to perform a scheduled inspection.

Inspection	Checklist
Daily or every 8 hours	A
Quarterly or every 250 hours	A + B
Semi-annually or every 500 hours	A + B + C
Annually or every 1000 hours	A + B + C + D
Two years or every 2000 hours	A + B + C + D + E

Maintenance Inspection Report

The maintenance inspection report contains checklists for each type of scheduled inspection.

Make copies of the *Maintenance Inspection Report* to use for each inspection. Maintain completed forms for a minimum of 4 years or in compliance with employer, jobsite and governmental regulations and requirements.

Pre-Delivery Preparation

Fundamentals

It is the responsibility of the dealer to perform the Pre-delivery Preparation.

The Pre-delivery Preparation is performed prior to each delivery. The inspection is designed to discover if anything is apparently wrong with a machine before it is put into service.

A damaged or modified machine must never be used. If damage or any variation from factory delivered condition is discovered, the machine must be tagged and removed from service.

Repairs to the machine may only be made by a qualified service technician, according to the manufacturer's specifications.

Scheduled maintenance inspections shall be performed by qualified service technicians, according to the manufacturer's specifications and the requirements listed in the responsibilities manual.

Instructions

Use the operator's manual on your machine.

The Pre-delivery Preparation consists of completing the Pre-operation Inspection, the Maintenance items and the Function Tests.

Use this form to record the results. Place a check in the appropriate box after each part is completed. Follow the instructions in the operator's manual.

If any inspection receives an N, remove the machine from service, repair and re-inspect it. After repair, place a check in the R box.

Legend

Y = yes, completed

N = no, unable to complete

R = repaired

Comments

Pre-Delivery Preparation	Y	N	R
Pre-operation inspection completed			
Maintenance items completed			
Function tests completed			

Model

Serial number

Date

Machine owner

Inspected by (print)

Inspector signature

Inspector title

Inspector company





Maintenance Inspection Report

Model
Serial number
Date
Hour meter
Machine owner
Inspected by (print)
Inspector signature
Inspector title
Inspector company

- Instructions**
- Make copies of this report to use for each inspection.
 - Select the appropriate checklist(s) for the type of inspection to be performed.

<input type="checkbox"/>	Daily or 8 hours Inspection:	A
<input type="checkbox"/>	Quarterly or 250 hours Inspection:	A+B
<input type="checkbox"/>	Semi-annually or 500 hours Inspection:	A+B+C
<input type="checkbox"/>	Annually or 1000 hours Inspection:	A+B+C+D
<input type="checkbox"/>	Two year or 2000 hours Inspection:	A+B+C+D+E

- Place a check in the appropriate box after each inspection procedure is completed.
- Use the step-by-step procedures in this section to learn how to perform these inspections.
- If any inspection receives an "N", tag and remove the machine from service, repair and re-inspect it. After repair, place a check in the "R" box.

Legend

Y = yes, acceptable
 N = no, remove from service
 R = repaired

Checklist A - Rev A	Y	N	R
A-1 Manuals and decals			
A-2 Pre-operation inspect			
A-3 Function tests			
Perform every 8 hours:			
A-4 Engine maintenance - Isuzu models			
A-5 Generator maintenance			
Perform after 10 miles:			
A-6 Axle maintenance			
Perform after 25 miles:			
A-6 Axle maintenance			
Perform after 50 miles:			
A-6 Axle maintenance			
Perform after 40 hours:			
A-7 30 day service			
Perform every 50 hours:			
A-8 Engine maintenance			
Perform weekly:			
A-9 Hitch maintenance			
Perform every 100 hours:			
A-10 Grease rotation bearing			
A-11 Engine maintenance - Kubota models			
Perform every 200 hours:			
A-12 Engine maintenance - Kubota models			

Checklist B - Rev A	Y	N	R
B-1 Battery			
B-2 Electrical wiring			
B-3 Tires and wheels			
B-4 Hydraulic oil analysis			
B-5 Engine maintenance - Isuzu models			
B-6 Generator maintenance			
Perform quarterly:			
B-7 Hitch coupler maintenance			
Perform every 400 hours:			
B-8 Engine maintenance - Kubota models			
Perform every 3000 miles:			
B-9 Axle maintenance			
Checklist C - Rev A			
C-1 Extend/retract cables and pulleys			
C-2 Engine maintenance			
Perform every 6000 miles:			
C-3 Axle maintenance			
Perform every 750 hours:			
C-5 Engine maintenance - Isuzu models			
Perform every 800 hours:			
C-6 Engine maintenance - Kubota models			

MAINTENANCE INSPECTION REPORT

Model
Serial number
Date
Hour meter
Machine owner
Inspected by (print)
Inspector signature
Inspector title
Inspector company

- Instructions**
- Make copies of this report to use for each inspection.
 - Select the appropriate checklist(s) for the type of inspection to be performed.

<input type="checkbox"/>	Daily or 8 hours Inspection:	A
<input type="checkbox"/>	Quarterly or 250 hours Inspection:	A+B
<input type="checkbox"/>	Semi-annually or 500 hours Inspection:	A+B+C
<input type="checkbox"/>	Annually or 1000 hours Inspection:	A+B+C+D
<input type="checkbox"/>	Two year or 2000 hours Inspection:	A+B+C+D+E

- Place a check in the appropriate box after each inspection procedure is completed.
- Use the step-by-step procedures in this section to learn how to perform these inspections.
- If any inspection receives an "N", tag and remove the machine from service, repair and re-inspect it. After repair, place a check in the "R" box.

Legend

Y = yes, acceptable
 N = no, remove from service
 R = repaired

Checklist D - Rev A		Y	N	R
D-1	Engine maintenance - Kubota models			
D-2	Tower rotation bearing bolts			
D-3	Hydraulic filter			
D-4	Engine maintenance - Isuzu models			
Perform every 1250 hours:				
D-5	Engine maintenance - Isuzu models			
Perform every 1500 hours:				
D-6	Engine maintenance			
D-7	Generator maintenance			
Perform annually:				
D-8	Tongue and outrigger jack maintenance			
Perform every 12,000 miles:				
D-9	Axle maintenance			

Checklist E - Rev A		Y	N	R
E-1	Test or replace hydraulic oil			
Perform every 3000 hours:				
E-2	Engine maintenance - Kubota models			
Perform every 2 years:				
E-3	Engine maintenance - Kubota models			
Perform every 4500 hours:				
E-4	Generator maintenance			
Perform every 15,000 hours:				
E-5	Generator maintenance			

Comments



Checklist A Procedures

REV A

A-1 Inspect the Manuals and Decals

Note: Terex specifications require that this procedure be performed daily or every 8 hours, whichever comes first.

Maintaining the operator's and safety manuals in good condition is essential to safe machine operation. Manuals are included with each machine and should be stored in the container provided in the cabinet. An illegible or missing manual will not provide safety and operational information necessary for a safe operating condition.

In addition, maintaining all of the safety and instructional decals in good condition is mandatory for safe machine operation. Decals alert operators and personnel to the many possible hazards associated with using this machine. They also provide users with operation and maintenance information. An illegible decal will fail to alert personnel of a procedure or hazard and could result in unsafe operating conditions.

- 1 Check to make sure that the operator's and safety manuals are present and complete in the storage container inside the cabinet.
 - 2 Examine the pages of each manual to be sure that they are legible and in good condition.
- ⦿ Result: The operator's manual is appropriate for the machine and all manuals are legible and in good condition.
 - ✗ Result: The operator's manual is not appropriate for the machine or all manuals are not in good condition or are illegible. Remove the machine from service until the manual is replaced.

- 3 Open the operator's manual to the decals inspection section. Carefully and thoroughly inspect all decals on the machine for legibility and damage.
- ⦿ Result: The machine is equipped with all required decals, and all decals are legible and in good condition.
 - ✗ Result: The machine is not equipped with all required decals, or one or more decals are illegible or in poor condition. Remove the machine from service until the decals are replaced.
- 4 Always return the manuals to the storage container after use.

Note: Contact your authorized Terex distributor if replacement manuals or decals are needed.

A-2 Perform Pre-operation Inspection

Note: Terex specifications require that this procedure be performed every 8 hours or daily, whichever comes first.

Completing a pre-operation inspection is essential to safe machine operation. The pre-operation inspection is a visual inspection performed by the operator prior to each work shift. The inspection is designed to discover if anything is apparently wrong with a machine before the operator performs the function tests. The pre-operation inspection also serves to determine if routine maintenance procedures are required.

Complete information on how to perform this procedure is available in the appropriate Operator's Manual. Refer to the Operator's Manual on your machine.

A-3 Perform Function Tests

Note: Terex specifications require that this procedure be performed every 8 hours or daily, whichever comes first.

Completing the function tests is essential to safe machine operation. Function tests are designed to discover any malfunctions before the machine is put into service. A malfunctioning machine must never be used. If malfunctions are discovered, the machine must be tagged and removed from service.

Complete information on how to perform this procedure is available in the appropriate Operator's Manual. Refer to the Operator's Manual on your machine.



REV A

CHECKLIST A PROCEDURES

A-4 Perform Engine Maintenance - Isuzu Models



Note: Engine specifications require that this procedure be performed every 8 hours or daily, whichever comes first.

Required maintenance procedures and additional engine information is available in the *Isuzu 4LE1 Diesel Engine Instruction Manual* (Isuzu part number IDE-6033).

Isuzu 4LE1 Diesel Engine Instruction Manual	
Terex part number	116133

A-5 Perform Generator Maintenance



Note: Generator specifications require that this procedure be performed every 8 hours or daily, whichever comes first.

Required maintenance procedures and additional generator information is available in the *Leroy Somer LSA 37 Installation and Maintenance Manual* (Leroy Somer part number 3664EN-09.2005/B) OR the *Marathon Installation, Operation and Maintenance Manual* (Marathon part number GPN012) OR the *Newage Installation, Service and Maintenance Manual* (Newage part number BCH-018).

Leroy Somer LSA 37 Installation and Maintenance Manual	
Terex part number	116118

Marathon Installation, Operation and Maintenance Manual	
Terex part number	116188

Newage Installation, Service and Maintenance Manual	
Terex part number	830001

A-6 Perform Axle Maintenance



Note: Axle specifications require that this procedure be performed initially and following a wheel change after the first 10, 25 and 50 miles.

Proper axle maintenance, following the axle manufacturer's maintenance schedule, is essential to good axle performance and service life. Failure to perform the maintenance procedures can lead to poor axle performance and component damage.

Required maintenance procedures and additional axle information is available in the *Axis Axle Operator Maintenance Manual* included with your machine.

Axis Axle Operator Maintenance Manual
Terex part number

116117

A-7 Perform 30 Day Service



The 30 day maintenance procedure is a one time procedure to be performed after the first 30 days or 40 hours of usage. After this interval, refer to the maintenance tables for continued scheduled maintenance.

- 1 Perform the following maintenance procedures:
 - B-3 Inspect the Tires, Wheels and Lug Nut Torque



REV A

CHECKLIST A PROCEDURES

A-8 Perform Engine Maintenance



Note: Engine specifications require that this procedure be performed every 50 hours.

Required maintenance procedures and additional engine information is available in the *Isuzu 4LE1 Diesel Engine Instruction Manual* (Isuzu part number IDE-6033) OR the *Kubota D-1105 and V-1505 Operator's Manual* (Kubota part number 16683-89169).

Isuzu 4LE1 Diesel Engine Instruction Manual
Terex part number 116133

Kubota D-1105 and V-1505 Operator's Manual
Terex part number 893020

A-9 Perform Hitch Maintenance



Note: Hitch specifications require that this procedure be performed weekly.

Required maintenance procedures and additional hitch information is available in the *Fulton Coupler User Manual* (Fulton part number F1937).

Fulton Coupler User Manual
Terex part number 150139

CHECKLIST A PROCEDURES

REV A

A-10 Grease the Turntable Rotation Bearing and Rotate Gear



Note: Terex specifications require that this procedure be performed every 100 hours of operation. Perform this procedure more often if dusty conditions exist.

Frequent application of lubrication to the turntable rotation bearing and rotate gear is essential to good machine performance and service life. Continued use of an improperly greased bearing and gear will result in component damage.

- 1 Lower all four outriggers to the ground and level the machine.
- 2 Remove the tower transport lock pin.
- 3 Raise the tower to a vertical position.
- 4 Locate the grease fitting on the inner race of the bearing.
- 5 Pump grease into the tower rotation bearing. Rotate the tower in increments of 4 to 5 inches / 10 to 13 cm at a time and repeat this step until the entire bearing has been greased.
- 6 Remove retaining fasteners from the the pinion gear guard. Remove the guard.
- 7 Apply grease to each tooth of the pinion gear.

- 8 Rotate the tower to transfer the grease from the pinion gear to the teeth of the rotation bearing.
- 9 Repeat steps 5 and 6 until all gear teeth are thoroughly greased.
- 10 Install the pinion gear guard and securely tighten the retaining fasteners. Do not overtighten.

Grease Specification

Chevron Ultra-duty grease, EP NLGI 2 (lithium based) or equivalent



REV A

CHECKLIST A PROCEDURES

A-11 Perform Engine Maintenance - Kubota Models



Note: Engine specifications require that this procedure be performed every 100 hours.

Required maintenance procedures and additional engine information is available in the *Kubota D-1105 and V-1505 Operator's Manual* (Kubota part number 16683-89169).

Kubota D-1105 and V-1505 Operator's Manual	
Terex part number	893020

A-12 Perform Engine Maintenance - Kubota Models



Note: Engine specifications require that this procedure be performed every 200 hours.

Required maintenance procedures and additional engine information is available in the *Kubota D-1105 and V-1505 Operator's Manual* (Kubota part number 16683-89169).

Kubota D-1105 and V-1505 Operator's Manual	
Terex part number	893020

Checklist B Procedures

REV A

B-1 Inspect the Battery



Note: Terex requires that this procedure be performed every 250 hours or quarterly, whichever comes first.

Proper battery condition is essential to good machine performance and operational safety. Improper fluid levels or damaged cables and connections can result in component damage and hazardous conditions.

▲WARNING Electrocutation hazard. Contact with hot or live circuits could result in death or serious injury. Remove all rings, watches and other jewelry.

▲WARNING Bodily injury hazard. Batteries contain acid. Avoid spilling or contacting battery acid. Neutralize battery acid spills with baking soda and water.

- 1 Put on protective clothing and eye wear.
- 2 Open the cabinet cover at the curb side of the machine and locate the battery.
- 3 Be sure that the battery cable connections are free of corrosion.

Note: Adding terminal protectors and a corrosion preventative sealant will help eliminate corrosion on the battery terminals and cables.

- 4 Be sure that the battery retainers and cable connections are tight.

B-2 Inspect the Electrical Wiring



Note: Terex requires that this procedure be performed every 250 hours or quarterly, whichever comes first.

Maintaining electrical wiring in good condition is essential to safe operation and good machine performance. Failure to find and replace burnt, chafed, corroded or pinched wires could result in unsafe operating conditions and may cause component damage.

▲WARNING Electrocutation hazard. Contact with hot or live circuits could result in death or serious injury. Remove all rings, watches and other jewelry.

- 1 Inspect the following areas for burnt, chafed, corroded and loose wires, and for a liberal coating of dielectric grease in the harness connections:
 - Mast
 - Chassis
 - Trailer lighting
- 2 Inspect for a liberal coating of dielectric grease in the harness connections between the generator, ballasts and the mast light assemblies.
- 3 Inspect the engine and generator area for burnt, chafed, corroded, pinched and loose wires, and for a liberal coating of dielectric grease in the harness connections.



REV A

CHECKLIST B PROCEDURES

B-3 Inspect the Tires and Wheels (including lug nut torque)



Note: Terex requires that this procedure be performed every 250 hours or quarterly, whichever comes first.

Maintaining the tires and wheels in good condition is essential to safe operation and good performance. Tire and/or wheel failure could result in a machine tip-over. Component damage may also result if problems are not discovered and repaired in a timely fashion.

▲WARNING Bodily injury hazard. An over-inflated tire can explode and could result in death or serious injury.

▲WARNING Tip-over hazard. Do not use temporary flat tire repair products.

- 1 Check the tire tread and sidewalls for cuts, cracks, punctures and unusual wear.
- 2 Check each wheel for damage, bends and cracked welds.
- 3 Check each lug nut for proper torque. Refer to Section 2, *Specifications*.
- 4 Check the air pressure of each tire. Refer to Section 2, *Specifications*.

B-4 Perform Hydraulic Oil Analysis



Note: Terex requires that this procedure be performed every 250 hours or quarterly, whichever comes first.

Replacement or testing of the hydraulic oil is essential for good machine performance and service life. Dirty oil and suction strainers may cause the machine to perform poorly and continued use may cause component damage. Extremely dirty conditions may require oil changes to be performed more often.

Note: Before replacing the hydraulic oil, the oil may be tested by an oil distributor for specific levels of contamination to verify that changing the oil is necessary. **If the hydraulic oil is not replaced at the two year inspection, test the oil quarterly. Replace the oil when it fails the test.** See E-1, *Test or Replace the Hydraulic Oil*.

**B-5
Perform Engine Maintenance -
Isuzu Models**



Note: Engine specifications require that this procedure be performed every 250 hours or quarterly, whichever comes first.

Required maintenance procedures and additional engine information is available in the *Isuzu 4LE1 Diesel Engine Instruction Manual* (Isuzu part number IDE-6033).

Isuzu 4LE1 Diesel Engine Instruction Manual	
Terex part number	116133

**B-6
Perform Generator Maintenance**



Note: Generator specifications require that this procedure be performed every 250 hours or quarterly, whichever comes first.

Required maintenance procedures and additional generator information is available in the *Leroy Somer LSA 37 Installation and Maintenance Manual* (Leroy Somer part number 3664EN-09.2005/B) OR the *Marathon Installation, Operation and Maintenance Manual* (Marathon part number GPN012) OR the *Newage Installation, Service and Maintenance Manual* (Newage part number BCH-018).

Leroy Somer LSA 37 Installation and Maintenance Manual	
Terex part number	116118

Marathon Installation, Operation and Maintenance Manual	
Terex part number	116188

Newage Installation, Service and Maintenance Manual	
Terex part number	830001



REV A

CHECKLIST B PROCEDURES

B-7 Perform Hitch Coupler Maintenance



Note: Hitch specifications require that this procedure be performed quarterly.

Required maintenance procedures and additional hitch information is available in the *Fulton Coupler User Manual* (Fulton part number F1937).

Fulton Coupler User Manual

Terex part number 150139

B-8 Perform Engine Maintenance - Kubota Models



Note: Engine specifications require that this procedure be performed every 400 hours.

Required maintenance procedures and additional engine information is available in the *Kubota D-1105 and V-1505 Operator's Manual* (Kubota part number 16683-89169).

Kubota D-1105 and V-1505 Operator's Manual

Terex part number 893020

B-9 Perform Axle Maintenance



Note: Axle specifications require that this procedure be performed quarterly or every 3000 miles, whichever comes first.

Proper axle maintenance, following the axle manufacturer's maintenance schedule, is essential to good axle performance and service life. Failure to perform the maintenance procedures can lead to poor axle performance and component damage.

Required maintenance procedures and additional axle information is available in the *Axis Axle Operator Maintenance Manual* included with your machine.

Axis Axle Operator Maintenance Manual

Terex part number 116117



Checklist C Procedures

REV A

C-1

Inspect the Tower Extend/ Retract Cables and Pulleys



Note: Terex requires that this procedure be performed every 500 hours or semi-annually, whichever comes first.

Detection of damage to the cables or pulleys is essential for safe machine operation. An unsafe working condition exists if these components are damaged and do not operate smoothly. Regular inspection of this system allows the inspector to identify changes in the operating condition that may indicate damage.

Note: Perform this procedure with the tower in the stowed position.

- 1 Lower all four outriggers to the ground and level the machine.
- 2 Remove the tower transport lock pin.
- 3 Fully extend the tower in a horizontal direction.

▲ DANGER Tip-over hazard. The machine will tip over when the tower is extended if the outriggers are not lowered to the ground.

- 4 Visually inspect the cables and components for the following:
 - frayed or broken wire strands
 - kinks in the cable
 - corrosion
 - paint or foreign materials
 - split or cracked cable ends
 - cables are on all pulleys
 - cables at end of adjustment range
 - no broken or damaged pulleys
 - no unusual or excessive pulley wear
 - all fasteners in place and secure

C-2

Perform Engine Maintenance



Note: Engine specifications require that this procedure be performed every 500 hours or semi-annually, whichever comes first.

Required maintenance procedures and additional engine information is available in the *Isuzu 4LE1 Diesel Engine Instruction Manual* (Isuzu part number IDE-6033) OR the *Kubota D-1105 and V-1505 Operator's Manual* (Kubota part number 16683-89169).

Isuzu 4LE1 Diesel Engine Instruction Manual

Terex part number

116133

Kubota D-1105 and V-1505 Operator's Manual

Terex part number

893020

C-3 Perform Axle Maintenance



Note: Axle specifications require that this procedure be performed every 6 months or 6000 miles, whichever comes first.

Proper axle maintenance, following the axle manufacturer's maintenance schedule, is essential to good axle performance and service life. Failure to perform the maintenance procedures can lead to poor axle performance and component damage.

Required maintenance procedures and additional axle information is available in the *Axis Axle Operator Maintenance Manual* included with your machine.

Axis Axle Operator Maintenance Manual	
Terex part number	116117

C-4 Perform Engine Maintenance - Isuzu Models



Note: Engine specifications require that this procedure be performed every 750 hours.

Required maintenance procedures and additional engine information is available in the *Isuzu 4LE1 Diesel Engine Instruction Manual* (Isuzu part number IDE-6033).

Isuzu 4LE1 Diesel Engine Instruction Manual	
Terex part number	116133



REV A

CHECKLIST C PROCEDURES

C-5**Perform Engine Maintenance -
Kubota Models**

Note: Engine specifications require that this procedure be performed every 800 hours.

Required maintenance procedures and additional engine information is available in the *Kubota D-1105 and V-1505 Operator's Manual* (Kubota part number 16683-89169).

Kubota D-1105 and V-1505 Operator's Manual

Terex part number

893020

Checklist D Procedures

REV A

D-1 Perform Engine Maintenance - Kubota Models



Note: Engine specifications require that this procedure be performed annually.

Required maintenance procedures and additional engine information is available in the *Kubota D-1105 and V-1505 Operator's Manual* (Kubota part number 16683-89169).

Kubota D-1105 and V-1505 Operator's Manual
Terex part number 893020

D-2 Check the Tower Rotation Bearing Bolts



Note: Terex requires that this procedure be performed every 1000 hours or annually, whichever comes first.

Maintaining proper torque on the tower rotation bearing bolts is essential to safe machine operation. Improper bolt torque could result in an unsafe operating condition and component damage.

- 1 Lower all four outriggers to the ground and level the machine.
- 2 Remove the tower transport lock pin.
- 3 Raise the tower to a vertical position.
- 4 Check to be sure that each tower mounting bolt is torqued in sequence to specification. Refer to Section 2, *Specifications*.

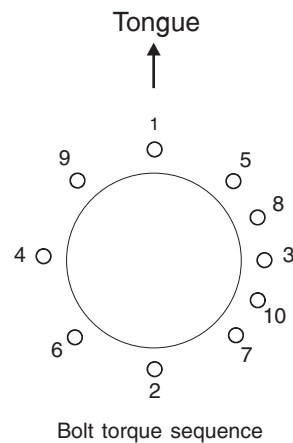



REV A

CHECKLIST D PROCEDURES

- 5 Check to be sure that each bearing mounting bolt under the tower support is torqued in sequence to specification. Refer to Section 2, *Specifications*.

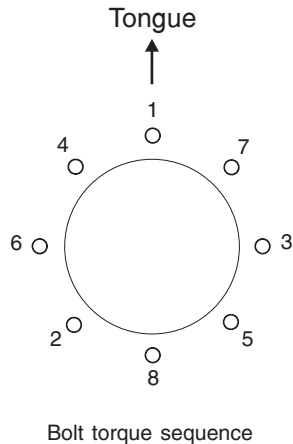

D-3

Replace the Hydraulic Return Filter



Note: Terex requires that this procedure be performed every 1000 hours or annually, whichever comes first.

Replacement of the hydraulic return filter is essential for good machine performance and service life. A dirty or clogged filter may cause the machine to perform poorly and continued use may cause component damage. Extremely dirty conditions may require that the filter be replaced more often.

CAUTION

Bodily injury hazard. Beware of hot oil. Contact with hot oil may cause severe burns.

- 1 Open the road side cabinet cover and locate the hydraulic return filter next to the power unit.
- 2 Place a suitable container under the hydraulic filter.
- 3 Clean the area around the filter. Remove the filter with an oil filter wrench.
- 4 Apply a thin layer of fresh oil to the gasket of the new oil filter.
- 5 Install the new filter and tighten it securely by hand. Clean up any oil that may have spilled.
- 6 Pull out the red Emergency Stop button (if equipped) to the on position located on the back panel of the light tower cabinet.
- 7 Activate any tower function and inspect the filter and related components to be sure that there are no leaks.
- 8 Use a permanent ink marker to write the date and number of hours from the hour meter on the oil filter.

CHECKLIST D PROCEDURES

REV A

**D-4
Perform Engine Maintenance -
Isuzu Models**

Note: Engine specifications require that this procedure be performed every 1000 hours or annually, whichever comes first.

Required maintenance procedures and additional engine information is available in the *Isuzu 4LE1 Diesel Engine Instruction Manual* (Isuzu part number IDE-6033).

Isuzu 4LE1 Diesel Engine Instruction Manual	
Terex part number	116133

**D-5
Perform Engine Maintenance -
Isuzu Models**

Note: Engine specifications require that this procedure be performed every 1250 hours.

Required maintenance procedures and additional engine information is available in the *Isuzu 4LE1 Diesel Engine Instruction Manual* (Isuzu part number IDE-6033).

Isuzu 4LE1 Diesel Engine Instruction Manual	
Terex part number	116133



REV A

CHECKLIST D PROCEDURES

D-6 Perform Engine Maintenance



Note: Engine specifications require that this procedure be performed every 1500 hours.

Required maintenance procedures and additional engine information is available in the *Isuzu 4LE1 Diesel Engine Instruction Manual* (Isuzu part number IDE-6033) OR the *Kubota D-1105 and V-1505 Operator's Manual* (Kubota part number 16683-89169).

Isuzu 4LE1 Diesel Engine Instruction Manual	
Terex part number	116133

Kubota D-1105 and V-1505 Operator's Manual	
Terex part number	893020

D-7 Perform Generator Maintenance



Note: Generator specifications require that this procedure be performed every 1500 hours or annually, whichever comes first.

Required maintenance procedures and additional generator information is available in the *Leroy Somer LSA 37 Installation and Maintenance Manual* (Leroy Somer part number 3664EN-09.2005/B) OR the *Marathon Installation, Operation and Maintenance Manual* (Marathon part number GPN012) OR the *Newage Installation, Service and Maintenance Manual* (Newage part number BCH-018).

Leroy Somer LSA 37 Installation and Maintenance Manual	
Terex part number	116118

Marathon Installation, Operation and Maintenance Manual	
Terex part number	116188

Newage Installation, Service and Maintenance Manual	
Terex part number	830001

CHECKLIST D PROCEDURES

REV A

D-8 Perform Tongue Jack and Outrigger Jack Maintenance



Note: Tongue and outrigger jack specifications require that this procedure be performed annually.

Required maintenance procedures and additional hitch information is available in the *Cequent Tongue Jack Use Manual* (Cequent part number F3282ML).

Cequent Tongue Jack Use Manual	
Terex part number	150140

D-9 Perform Axle Maintenance



Note: Axle specifications require that this procedure be performed annually or every 12,000 miles, whichever ever comes first.

Proper axle maintenance, following the axle manufacturer's maintenance schedule, is essential to good axle performance and service life. Failure to perform the maintenance procedures can lead to poor axle performance and component damage.

Required maintenance procedures and additional axle information is available in the *Axis Axle Operator Maintenance Manual* included with your machine.

Axis Axle Operator Maintenance Manual	
Terex part number	116117



Checklist E Procedures

REV A

E-1

Test or Replace the Hydraulic Oil



Note: Terex requires that this procedure be performed every 2000 hours or every two years, whichever comes first.

Replacement or testing of the hydraulic oil is essential for good machine performance and service life. Dirty oil and suction strainers may cause the machine to perform poorly and continued use may cause component damage. Extremely dirty conditions may require oil changes to be performed more often.

Note: Before replacing the hydraulic oil, the oil may be tested by an oil distributor for specific levels of contamination to verify that changing the oil is necessary. **If the hydraulic oil is not replaced at the two year inspection, test the oil quarterly. Replace the oil when it fails the test.**

Note: When removing a hose assembly or fitting, the O-ring on the fitting and/or hose end must be replaced and then torqued to specification during installation. Refer to Section 2, *Hydraulic Hose and Fitting Torque Specifications*.

- 1 Open both cabinet covers.
- 2 Tag and disconnect the battery cables from the battery.

▲WARNING Electrocutation hazard. Contact with electrically charged circuits could result in death or serious injury. Remove all rings, watches and other jewelry.

- 3 Tag, disconnect and plug the hydraulic hoses from the power unit. Cap the fittings.

▲WARNING Bodily injury hazard. Spraying hydraulic oil can penetrate and burn skin. Loosen hydraulic connections very slowly to allow the oil pressure to dissipate gradually. Do not allow oil to squirt or spray.

- 4 Tag and disconnect the electrical wiring and cables from the power unit.
- 5 Support and secure the power unit to a suitable lifting device.
- 6 Remove the fasteners securing the power unit to the cabinet. Carefully remove the power unit from the curb side of the machine.

▲NOTICE Component damage hazard. The hydraulic reservoir is plastic and may become damaged if allowed to fall when removed from the machine.

- 7 Place a suitable container under the hydraulic reservoir. Refer to Section 2, *Specifications* for capacity specifications.
- 8 Remove the hydraulic reservoir retaining fasteners from the power unit. Carefully remove the hydraulic reservoir from the power unit and completely drain it into a suitable container.

▲CAUTION Bodily injury hazard. Beware of hot oil. Contact with hot oil may cause severe burns.

CHECKLIST E PROCEDURES

REV A

- 9 Remove the suction strainer and clean it using a mild solvent.
- 10 Rinse out the inside of the reservoir using a mild solvent.
- 11 Install the suction strainer.
- 12 Install the hydraulic reservoir onto the power unit.
- 13 Install the hydraulic reservoir retaining fasteners and securely tighten. Do not overtighten.
- 14 Install the hydraulic power unit onto the machine.
- 15 Fill the reservoir with hydraulic oil to within a 1/2" from the top with the cylinders collapsed.
- 16 Clean up any oil that may have spilled. Properly discard the used oil.
- 17 Operate all machine functions through a full cycle and check for leaks.
- 18 Operate all machine functions through 5-10 full cycles to fully remove air from the system.
- 19 Make sure unit is in a clear area during steps 17 and 18 as air in the cylinders can cause sudden movements of the tower.

E-2**Perform Engine Maintenance -
Kubota Models**

Note: Engine specifications require that this procedure be performed every 3000 hours.

Required maintenance procedures and additional engine information is available in the *Kubota D-1105 and V-1505 Operator's Manual* (Kubota part number 16683-89169).

Kubota D-1105 and V-1505 Operator's Manual

Terex part number

893020



REV A

CHECKLIST E PROCEDURES

E-3 Perform Engine Maintenance - Kubota Models



Note: Engine specifications require that this procedure be performed every 2 years.

Required maintenance procedures and additional engine information is available in the *Kubota D-1105 and V-1505 Operator's Manual* (Kubota part number 16683-89169).

Kubota D-1105 and V-1505 Operator's Manual	
Terex part number	893020

E-4 Perform Generator Maintenance



Note: Generator specifications require that this procedure be performed every 4500 hours or every 3 years, whichever comes first.

Required maintenance procedures and additional generator information is available in the *Leroy Somer LSA 37 Installation and Maintenance Manual* (Leroy Somer part number 3664EN-09.2005/B) OR the *Marathon Installation, Operation and Maintenance Manual* (Marathon part number GPN012) OR the *Newage Installation, Service and Maintenance Manual* (Newage part number BCH-018).

Leroy Somer LSA 37 Installation and Maintenance Manual	
Terex part number	116118

Marathon Installation, Operation and Maintenance Manual	
Terex part number	116188

Newage Installation, Service and Maintenance Manual	
Terex part number	830001

E-5**Perform Generator Maintenance**

Note: Generator specifications require that this procedure be performed every 15000 hours or every 19 years, whichever comes first.

Required maintenance procedures and additional generator information is available in the *Leroy Somer LSA 37 Installation and Maintenance Manual* (Leroy Somer part number 3664EN-09.2005/B) OR the *Marathon Installation, Operation and Maintenance Manual* (Marathon part number GPN012) OR the *Newage Installation, Service and Maintenance Manual* (Newage part number BCH-018).

Leroy Somer LSA 37 Installation and Maintenance Manual

Terex part number 116118

Marathon Installation, Operation and Maintenance Manual

Terex part number 116188

Newage Installation, Service and Maintenance Manual

Terex part number 830001

Repair Procedures



Observe and Obey:

- ☑ Repair procedures shall be completed by a person trained and qualified on the repair of this machine.
- ☑ Immediately tag and remove from service a damaged or malfunctioning machine.
- ☑ Repair any machine damage or malfunction before operating the machine.

Before Repairs Start:

- ☑ Read, understand and obey the safety rules and operating instructions in the appropriate operator's manual on your machine.
- ☑ Be sure that all necessary tools and parts are available and ready for use.
- ☑ Use only Terex approved replacement parts.
- ☑ Read each procedure completely and adhere to the instructions. Attempting shortcuts may produce hazardous conditions.
- ☑ Unless otherwise specified, perform each repair procedure with the machine in the following configuration:
 - Machine parked on a firm, level surface
 - Key switch in the off position (manual start models)
 - Toggle switch in the off position (automatic start models)
 - Mast in the stowed position
 - Light switches in the off position
 - Wheels chocked

About This Section

Most of the procedures in this section should only be performed by a trained service professional in a suitably equipped workshop. Select the appropriate repair procedure after troubleshooting the problem. Perform disassembly procedures to the point where repairs can be completed. To re-assemble, perform the disassembly steps in reverse order.

Symbols Legend



Safety alert symbol—used to alert personnel to potential personal injury hazards. Obey all safety messages that follow this symbol to avoid possible injury or death.



Indicates an imminently hazardous situation which, if not avoided, will result in death or serious injury.



Indicates a potentially hazardous situation which, if not avoided, could result in death or serious injury.



Indicates a potentially hazardous situation which, if not avoided, may cause minor or moderate injury.



Indicates a potentially hazardous situation which, if not avoided, may result in property damage.

- ⦿ Indicates that a specific result is expected after performing a series of steps.
- ⊗ Indicates that an incorrect result has occurred after performing a series of steps.

Lighting

REV A

1-1 Lighting

How to Remove a Lamp

▲ DANGER High voltage. Exposure to electrical wires or electrical current will result in death or serious injury. Remove all rings, watches and other jewelry. Turn off all power when not needed for testing. Use extreme caution when working with high voltage electrical components.

▲ CAUTION Burn hazard. Contact with hot lamp components may cause severe burns. Use caution when working around lamps.

- 1 Turn off all machine power.
- 2 Remove the light lens mounting fasteners and remove the lens.
- 3 Remove the spring securing the lamp to the lamp retainer.

NOTICE Component damage hazard. Contacting the lamp with bare skin can cause damage to the lamp. Do not allow bare-skin contact with the lamps.

- 4 Wrap a clean cloth around the lamp and remove the lamp from the socket.

Note: Be sure to wrap a clean cloth around a lamp when installing a lamp into a lamp socket.

How to Check Line Voltage

Correct line voltage at the lamp socket is essential for proper operation of the lighting system.

▲ DANGER Electrocutation hazard. Exposure to high voltage electrical wires or electrical current will result in death or serious injury. Remove all rings, watches and other jewelry. Turn off all power when not needed for testing. Use extreme caution when working with high voltage electrical components.

- 1 Turn off all machine power.
- 2 Remove the cover from the lamp junction box.
Note: The junction box is located between the light housings at the top of the mast.
- 3 Locate the correct wiring for the lamp to be tested.
- 4 Connect a voltmeter to the lamp wires.
- 5 Start the engine.
- 6 Turn the appropriate circuit breaker light switch to the "ON" position.
- 7 Observe the voltage as the lamps warm up. Refer to the following chart.

Note: It can take up to 5 minutes for the lights to reach full intensity. If the lights are turned off and then turned back on while they are still warm, they may not light up again for 10 to 20 minutes.



REV A

LIGHTING

Time	Line Voltage
Initial ignition	415V AC
30 seconds	412V AC
1 minute	413V AC
2 minutes	416V AC
5 minutes	246V AC
10 minutes	251V AC

Note: If the voltage reading remains high during warm up, check for loose or broken wire connections OR the lamp may be faulty.

Note: The voltage readings provided in the chart are averages; voltage on your machine may vary.

How to Check the Open Circuit Voltage

Correct line voltage at the lamp socket is essential for proper operation of the lighting system.

⚠ DANGER Electrocutation hazard. Exposure to high voltage electrical wires or electrical current will result in death or serious injury. Remove all rings, watches and other jewelry. Turn off all power when not needed for testing. Use extreme caution when working with high voltage electrical components.

- 1 Turn off all machine power.
- 2 Locate the electrical cable of the lamp to be tested. Disconnect the cable from the junction box attached to the light bar.
- 3 Set a voltmeter to read 0 to 750V AC. Insert the leads of the voltmeter into pins A and B of the electrical connector socket at the junction box.

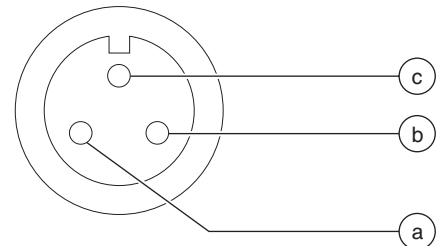

- 4 Start the engine.
- 5 Turn the appropriate circuit breaker light switch to the "ON" position and observe the reading on the voltmeter. Refer to the following chart.

Open Circuit Voltage Specification

375V AC to 465V AC

Note: If there is no reading on the meter. Repair or replace the capacitor, ballast or wiring.

Light Bar Components

REV A

2-1 Light Bar

How to Remove the Light Bar Assembly

Note: Perform this procedure with the tower in the stowed position.

Note: When removing a hose assembly or fitting, the O-ring on the fitting and/or hose end must be replaced and then torqued to specification during installation. Refer to Section 2, *Hydraulic Hose and Fitting Torque Specifications*.

- 1 Tag, disconnect and plug the light bar cylinder hydraulic hoses. Cap the fittings on the cylinder.

⚠ WARNING Bodily injury hazard. Spraying hydraulic oil can penetrate and burn skin. Loosen hydraulic connections very slowly to allow the oil pressure to dissipate gradually. Do not allow oil to squirt or spray.

- 2 Tag and disconnect the lamp electrical cables from each junction box. Do not disconnect the main power cables from the junction boxes
- 3 Remove the fasteners securing each junction box to the light bar.
- 4 Remove the hose and cable clamp retaining fasteners from the light bar and remove the clamp. Lay the hydraulic hoses and main power cables, with junction boxes attached, over the back of the cabinet.
- 5 Attach a lifting strap from an overhead crane to the light bar assembly. Support the light bar. Do not apply any lifting pressure.

- 6 Remove the pin retaining fasteners from light bar lift cylinder barrel-end pivot pin "D". Place a rod through the pin and twist to remove the pin.
- 7 Remove the pin retaining fasteners from the light bar pivot pin "B" and the light bar lever pivot pin "A". Place a rod through the pins and twist to remove the pins.

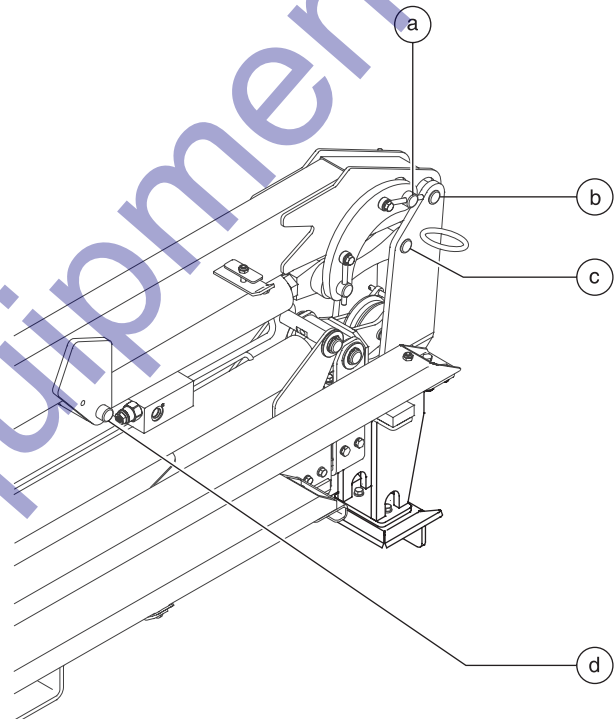

- a light bar lever pivot pin
- b light bar pivot pin
- c light bar connecting link pivot pin
- d cylinder barrel-end pivot pin

- 8 Carefully remove the light bar assembly from the machine.

⚠ WARNING Crushing hazard. The light bar assembly could become unbalanced and fall when removed from the machine if not properly supported by the overhead crane.

Note: During removal, the overhead crane strap will need to be carefully adjusted for proper balancing.



REV A

LIGHT BAR COMPONENTS

2-2

Light Bar Lift Cylinder

How to Remove the Light Bar Lift Cylinder

The light bar lift cylinder raises and lowers the light bar assembly. The light bar lift cylinder is equipped with counterbalance valves to prevent movement in the event of a hydraulic line failure.

Note: Perform this procedure with the tower in the stowed position.

Note: When removing a hose assembly or fitting, the O-ring on the fitting and/or hose end must be replaced and then torqued to specification during installation. Refer to Section 2, *Hydraulic Hose and Fitting Torque Specifications*.

- 1 Tag, disconnect and plug the light bar cylinder hydraulic hoses. Cap the fittings on the cylinder.

▲WARNING Bodily injury hazard. Spraying hydraulic oil can penetrate and burn skin. Loosen hydraulic connections very slowly to allow the oil pressure to dissipate gradually. Do not allow oil to squirt or spray.

- 2 Support the cylinder with a suitable device to prevent it from falling.
- 3 Remove the pin retaining fasteners from both the rod end and barrel-end pivot pins.
- 4 Place a rod through the pins and twist to remove. Remove the cylinder from the machine.

Tower Components

REV A

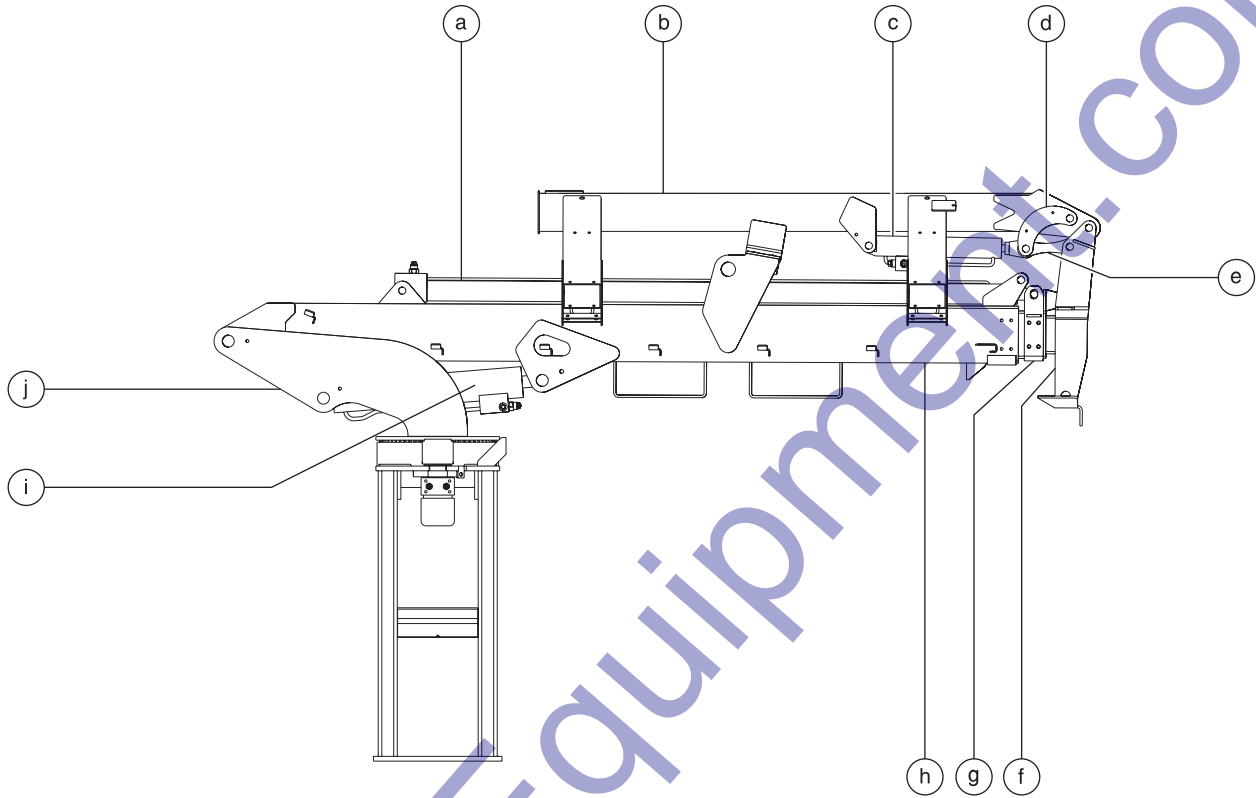

- a tower extension cylinder
- b light bar
- c light bar cylinder
- d light bar lever
- e light bar link
- f tower tube number 3
- g tower tube number 2
- h tower tube number 1
- i tower lift cylinder
- j tower rotation riser

REV A

TOWER COMPONENTS

3-1 Plastic Cable Track

How to Remove the Cable Track

The tower cable track guides the cables and hoses running up the tower. It can be repaired link by link without removing the cables and hoses that run through it. Removing the entire tower cable track is only necessary when performing major repairs that involve removing the tower.

How to Repair the Plastic Cable Track

NOTICE Component damage hazard. The tower cable track can be damaged if it is twisted.

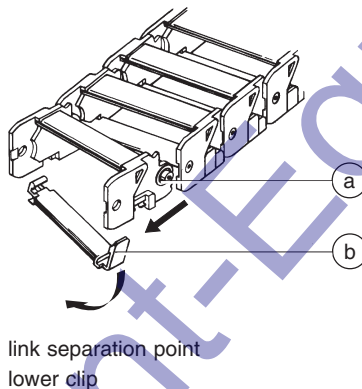

- 1 Use a slotted screwdriver to pry down on the lower clip.
- 2 Repeat step 1 for each link.
- 3 To remove a single link, open the lower clip and then use a screw driver to pry the link to the side.

3-2 Tower Assembly

How to Remove the Tower Assembly

WARNING Bodily injury hazard. The procedures in this section require specific repair skills, lifting equipment and a suitable workshop. Attempting this procedure without these skills and tools could result in death or serious injury and significant component damage. Dealer service is required.

Note: When removing a hose assembly or fitting, the O-ring on the fitting and/or hose end must be replaced and then torqued to specification during installation. Refer to Section 2, *Hydraulic Hose and Fitting Torque Specifications*.

- 1 Remove the light bar. See 2-1, *How to Remove the Light Bar Assembly*.
- 2 Remove the cable track tube retaining fasteners at the number 3 tower tube.
- 3 Remove the hose and cable clamp fasteners and clamps from the underside of the cable track on the side of tower tube number 1.
- 4 Place blocks between the cable track tube and the lower cable track. Secure the cable track together.

TOWER COMPONENTS

REV A

- 5 Attach a suitable lifting device to the cable track. Carefully remove the cable track from the tower and rest it on top of the cabinet.

NOTICE Component damage hazard. Cables and hoses can become damaged if they are kinked or pinched.

- 6 Place a block under the tower lift cylinder for support.
- 7 Remove the pin retaining fasteners from the tower lift cylinder rod-end pivot pin.
- 8 Use a soft metal drift to remove the pin. Rest the tower lift cylinder on the block.
- 9 Tag, disconnect and plug the tower extension cylinder hydraulic hoses. Cap the fittings on the cylinder.

WARNING Bodily injury hazard. Spraying hydraulic oil can penetrate and burn skin. Loosen hydraulic connections very slowly to allow the oil pressure to dissipate gradually. Do not allow oil to squirt or spray.

- 10 Position the forks from a forklift into the forklift pockets located under the tower. Secure the tower to the forks.
- 11 Remove the transport lock pin from the tower near the tower rest pad.
- 12 Remove the pin retaining fasteners from the tower pivot pin at the tower rotation riser.
- 13 Use a soft metal drift to remove the tower pivot pin. Carefully remove the tower assembly from the machine and place it on a structure capable of supporting it.

WARNING Crushing hazard. The tower assembly could become unbalanced and fall when removed from the machine if not properly supported and secured to the forklift.

How to Disassemble the Tower

Note: When removing a hose assembly or fitting, the O-ring on the fitting and/or hose end must be replaced and then torqued to specification during installation. Refer to Section 2, *Hydraulic Hose and Fitting Torque Specifications*.

- 1 Remove the tower assembly. See 3-2, *How to Remove the Tower Assembly*.
- 2 Tag, disconnect and plug the light bar lift cylinder hydraulic hoses. Cap the fittings on the cylinder.

WARNING Bodily injury hazard. Spraying hydraulic oil can penetrate and burn skin. Loosen hydraulic connections very slowly to allow the oil pressure to dissipate gradually. Do not allow oil to squirt or spray.

- 3 Attach a suitable lifting device to the light bar cylinder.
- 4 Remove the pin retaining fasteners from the light bar link pivot pin. Use a soft metal drift to remove the pin. Remove the cylinder from the tower assembly with links and levers attached.

Note: There is a spacer tube between the two links that may fall out when the pivot pin is removed.

- 5 Remove the cable retaining nut from the extend cable at the extension end of the tower, located near the extend cylinder rod-end pivot pin. Pull the cable end out of the pivot pin.



REV A

TOWER COMPONENTS

6 Remove the external snap rings from both the tower extension cylinder rod-end pivot pin and the extend cable pivot pin. Use a soft metal drift to remove the pins.

7 Attach a lifting strap from an overhead crane to the tower extension cylinder.

8 Remove the external snap rings from the tower extension cylinder barrel-end pivot pin. Use a soft metal drift to remove the pin. Carefully remove the cylinder from the machine.

WARNING Crushing hazard. The tower extension cylinder could become unbalanced and fall when removed from the machine if not properly supported by the overhead crane.

9 Remove the cable retaining nut from the retract cable, located on the bottom of tower tube number 1, at the extension end of the tower.

10 Label and remove the wear pads from the extension end of the number 1 tower tube.

11 Attach a lifting strap from an overhead crane to the number 2 and 3 tower tubes.

12 Support and slide the number 2 and 3 tower tubes out of the number 1 tower tube and place them on a structure capable of supporting them.

WARNING Crushing hazard. The number 2 and 3 tower tubes could become unbalanced and fall when removed from the number 1 tube if not properly supported by the overhead crane.

CAUTION Bodily injury hazard. Cables can fray. Always wear adequate hand protection when handling the cable.

NOTICE Component damage hazard. Cables can be damaged if they are kinked or pinched.

Note: During removal, the overhead crane strap will need to be carefully adjusted for proper balancing.

Note: As the number 2 and 3 tower tubes are removed from the number 1 tower tube, guide the retract cable out from the slot in the bottom of the number 1 tower tube.

13 Working at the extension end of the number 2 tower tube, remove the cotter pins from the two clevis pins that surround the cable pulley. Remove the clevis pins. Do not remove the pulley clevis pin.

Note: Always use a new cotter pin when installing a clevis pin.

TOWER COMPONENTS

REV A

- 14 Pull the extend cable free of the pulley mount and lay it flat on top of the number 3 tower tube.

CAUTION Bodily injury hazard. Cables can fray. Always wear adequate hand protection when handling the cable.

- 15 Label and remove the wear pads from the extension end of the number 2 tower tube.
- 16 Attach a lifting strap from an overhead crane to the number 3 tower tube.
- 17 Support and slide the number 3 tower tube from the number 2 tower tube and place it on a structure capable of supporting it.

WARNING Crushing hazard. The number 2 and 3 tower tubes could become unbalanced and fall when removed from the number 1 tube if not properly supported by the overhead crane.

CAUTION Bodily injury hazard. Cables can fray. Always wear adequate hand protection when handling the cable.

NOTICE Component damage hazard. Cables can be damaged if they are kinked or pinched.

Note: During removal, the overhead crane strap will need to be carefully adjusted for proper balancing.

3-3 Tower Lift Cylinder

How to Remove the Tower Lift Cylinder

The tower lift cylinder raises and lowers the tower assembly. The tower lift cylinder is equipped with counterbalance valves to prevent movement in the event of a hydraulic line failure.

Note: When removing a hose assembly or fitting, the O-ring on the fitting and/or hose end must be replaced and then torqued to specification during installation. Refer to Section 2, *Hydraulic Hose and Fitting Torque Specifications*.

- 1 Tag, disconnect and plug the tower lift cylinder hydraulic hoses. Cap the fittings on the cylinder.

WARNING Bodily injury hazard. Spraying hydraulic oil can penetrate and burn skin. Loosen hydraulic connections very slowly to allow the oil pressure to dissipate gradually. Do not allow oil to squirt or spray.

- 2 Support both ends of the cylinder with a suitable device to prevent it from falling.
- 3 Remove the pin retaining fasteners from both the rod end and barrel-end pivot pins.
- 4 Place a rod through the pins and twist to remove. Guide the cylinder out the pivot end of the tower and carefully remove the cylinder from the machine.

NOTICE Component damage hazard. Cables and hoses can be damaged if the cylinder is dragged across them.

REV A

TOWER COMPONENTS

3-4 Tower Extension Cylinder

How to Remove the Tower Extension Cylinder

The tower extension cylinder extends and retracts the tower assembly. The cylinder is used to extend and retract the number 2 tower tube while cables are used to extend and retract the number 3 tower tube. The tower extension cylinder is equipped with counterbalance valves to prevent movement in the event of a hydraulic line failure.

Note: When removing a hose assembly or fitting, the O-ring on the fitting and/or hose end must be replaced and then torqued to specification during installation. Refer to Section 2, *Hydraulic Hose and Fitting Torque Specifications*.

- 1 Tag, disconnect and plug the tower extension cylinder hydraulic hoses. Cap the fittings on the cylinder.

WARNING Bodily injury hazard. Spraying hydraulic oil can penetrate and burn skin. Loosen hydraulic connections very slowly to allow the oil pressure to dissipate gradually. Do not allow oil to squirt or spray.

- 2 Attach a lifting strap from an overhead crane to the tower extension cylinder.

- 3 Remove the external snap rings from the tower extension cylinder rod-end pivot pin. Use a soft metal drift to remove the pin.
- 4 Remove the external snap rings from the tower extension cylinder barrel-end pivot pin. Use a soft metal drift to remove the pin.
- 5 Slide the extension cylinder towards the tongue end of the machine slightly and carefully remove the cylinder from the machine.

WARNING Crushing hazard. The tower extension cylinder could become unbalanced and fall when removed from the machine if not properly supported by the overhead crane.

TOWER COMPONENTS

REV A

3-5 Tower Rotation Motor

How to Remove the Tower Rotation Motor

Note: When removing a hose assembly or fitting, the O-ring on the fitting and/or hose end must be replaced and then torqued to specification during installation. Refer to Section 2, *Hydraulic Hose and Fitting Torque Specifications*.

Note: Perform this procedure with the tower in the stowed position and the transport lock pin installed.

- 1 Tag, disconnect and plug the tower rotation motor hydraulic hoses. Cap the fittings on the motor.

⚠ WARNING Bodily injury hazard. Spraying hydraulic oil can penetrate and burn skin. Loosen hydraulic connections very slowly to allow the oil pressure to dissipate gradually. Do not allow oil to squirt or spray.

- 2 Remove the rotation motor pinion gear guard fasteners. Remove the guard.
- 3 Remove the rotation motor mounting fasteners. Remove the motor from the machine.

Note: When installing a rotation motor, the gear backlash will need to be adjusted. See *How to Adjust the Tower Rotation Gear Backlash*.

How to Adjust the Tower Rotation Gear Backlash

The rotation motor mounting fasteners are located in slotted holes to allow the adjustment of gear backlash between the motor pinion gear and the rotation bearing ring gear. Proper backlash adjustment is critical to safe machine operation and component service life. An improper backlash adjustment could decrease component service life and may result in component damage.

Note: Perform this procedure with the tower in the stowed position and the transport lock pin installed.

- 1 Loosen the tower rotation motor mounting fasteners. Do not remove them.
- 2 Push the rotation motor towards the rotation bearing as far as possible (this will push the pinion gear into the rotation bearing ring gear).
- 3 Loosen the lock nut on the adjustment bolt.
- 4 Adjust the lock nuts until there is approximately $\frac{1}{16}$ inch / 1.5 mm gap between the end of the bolt and the rotation motor case. Tighten the lock nuts of the adjustment bolt.
- 5 Rotate the rotation motor away from the bearing until it contacts the adjustment bolt. Torque the rotation motor fasteners to specification. Refer to Section 2, *Specifications*.
- 6 Rotate the tower through full range of motion. Check for tight spots and binding. Readjust if necessary.



Kubota D1105-E / V1505-E Engine

REV A

4-1 Timing Adjustment

Complete information to perform this procedure is available in the *Kubota 05 Series Workshop Manual* (Kubota part number: 97897-02432).

Kubota 05 Series Workshop Manual

Terex part number

31742

4-2 Glow Plugs

How to Check the Glow Plugs

- 1 Disconnect the wiring and buss bar from the glow plugs.
 - 2 Connect the leads from an ohmmeter between each glow plug terminal and ground.
- ⊕ Result: The resistance should be approximately 1Ω.
 - ⊗ Result: The resistance is 0Ω or greater than 1Ω. The glow plug is faulty.

4-3 Coolant Temperature and Oil Pressure Switches

The engine coolant temperature switch is a normally open switch. The switch contacts close at approximately 225°F / 107°C. If the coolant temperature rises above the switch point, the switch contacts close and the engine will shut off to prevent damage. The engine will not start until the temperature drops below the switch point. Additionally a low coolant level can cause the coolant temperature switch to not work properly. Make sure that the coolant system is at the proper level.

The engine oil pressure switch is a normally closed switch. The switch contacts open at approximately 7 psi / 0.48 bar. If the oil pressure drops below the switch point, the contacts open and the engine will shut off to prevent damage.

Isuzu 4LE1 Engine

REV A

5-1 Timing Adjustment

Complete information to perform this procedure is available in the *Isuzu 4LE1 Workshop Manual* (Isuzu part number: IDE-2270).

Isuzu 4LE1 Workshop Manual	
Terex part number	116166

5-2 Glow Plugs

How to Check the Glow Plugs

- 1 Disconnect the wiring and buss bar from the glow plugs.
 - 2 Connect the leads from an ohmmeter between each glow plug terminal and ground.
- ⊕ Result: The resistance should be approximately 1Ω.
 - ⊗ Result: The resistance is 0Ω or greater than 1Ω. The glow plug is faulty.

5-3 Coolant Temperature and Oil Pressure Switches

The engine coolant temperature switch is a normally open switch. The switch contacts close at approximately 221°F / 105°C. If the coolant temperature rises above the switch point, the switch contacts close and the engine will shut off to prevent damage. The engine will not start until the temperature drops below the switch point. Additionally a low coolant level can cause the coolant temperature switch to not work properly. Make sure that the coolant system is at the proper level.

The engine oil pressure switch is a normally closed switch. The switch contacts open at approximately 14 psi / 0.96 bar. If the oil pressure drops below the switch point, the contacts open and the engine will shut off to prevent damage.



Generator

REV A

6-1 Generator

How to Remove the Generator Capacitor Cover - Leroy Somer Models

▲ DANGER Electrocutation hazard. Exposure to high voltage electrical wires or electrical current will result in death or serious injury. Remove all rings, watches and other jewelry. Turn off all power when not needed for testing. Use extreme caution when working with high voltage electrical components.

Note: Be sure the engine has been turned off for at least 15 minutes before servicing the machine. Use a voltmeter to confirm there is no residual voltage in the capacitors.

- 1 Loosen but do not remove the fasteners securing the capacitor cover to the top of the generator.
- ▲ CAUTION** Burn hazard. Contact with hot engine components may cause severe burns. Use caution when working around a hot engine.
- 2 Pull the cover off the top of the generator to access the wire harness where it connects to the generator.
 - 3 Tag and disconnect the wires at the top of the generator. Remove the cover.

How to Check a Generator Capacitor - Leroy Somer Models

▲ DANGER Electrocutation hazard. Exposure to high voltage electrical wires or electrical current will result in death or serious injury. Remove all rings, watches and other jewelry. Turn off all power when not needed for testing. Use extreme caution when working with high voltage electrical components.

▲ DANGER Electrocutation hazard. Attempting to service the machine before the capacitors are fully discharged will result in death or serious injury.

Note: Be sure the engine has been turned off for at least 15 minutes before servicing the machine. Use a voltmeter to confirm there is no residual voltage in the capacitors.

- 1 Remove the generator capacitor cover. See 6-1, *How to Remove the Generator Capacitor Cover*.
- 2 Tag and disconnect the wires attached to the capacitor(s).
- 3 Using an insulated conductor or a screwdriver with an insulated handle, discharge the capacitor by shorting across the capacitor terminals. Repeat for the second capacitor, if equipped.

▲ DANGER Electrocutation hazard. Exposure to high voltage electrical wires or electrical current will result in death or serious injury. Remove all rings, watches and other jewelry. Use extreme caution when working with high voltage electrical components.

- 4 With an ohmmeter set to its highest resistance scale, connect the ohmmeter leads to the capacitor terminals and observe the reading on the meter. Then, reverse the connections and observe the reading on the meter.

GENERATOR

REV A

- ⊙ Result: The meter indicates a very low resistance which then gradually increases AND a very high resistance which then gradually decreases. The capacitor is working.
- ⊗ Result: The meter indicates a very high resistance which does not decrease. The capacitor is faulty and should be replaced.
- ⊗ Result: The meter indicates a very low resistance which does not increase. The capacitor is faulty and should be replaced.

Probable causes of capacitor failure:

- Starting engine with circuit breakers on.
- Shutting off engine with circuit breakers on.
- Normal end-of-life failure.
- Overheated due to light fixture heat or high ambient temperature.
- Incorrect capacitor voltage rating.

How to Remove the Generator - Marathon Generator Models

⚠ DANGER Electrocutation hazard. Exposure to high voltage electrical wires or electrical current will result in death or serious injury. Remove all rings, watches and other jewelry. Turn off all power when not needed for testing. Use extreme caution when working with high voltage electrical components.

Note: Be sure the engine has been turned off for at least 15 minutes before servicing the machine. Use a voltmeter to confirm there is no residual voltage in the capacitors.

- 1 Extend all four outriggers. Lower each outrigger until they make contact with the ground.
- 2 Raise the tower to a vertical position. Do not extend the tower or raise the light bar. Turn the machine off.

- 3 Open each cabinet door. Remove the hinge retaining fasteners from the cabinet top for each cabinet door.
- 4 Disconnect the gas struts from each cabinet door. Remove each door from the machine.
- 5 Locate the domelight mounted to the cabinet top above the engine. Remove the lens from the domelight. Remove the domelight mounting fasteners and set the domelight aside.
- 6 Locate the wiring for the limit switch located at the transport lock pin. Tag and disconnect the limit switch wiring from inside the engine compartment.
- 7 Remove the limit switch mounting fasteners and set the switch aside.
- 8 Remove the tower rest pad weldment fasteners. Remove the rest pad from the cabinet.
- 9 Support the cabinet top with a suitable lifting device.
- 10 Remove all fasteners securing the cabinet top to the cabinet end panels. Carefully remove the cabinet top from the machine.

⚠ CAUTION Crushing hazard. The cabinet top may become unbalanced and fall if not properly supported when removed from the machine.

Models with Marathon generators:

- 11 Disconnect the battery from the machine.

⚠ WARNING Electrocutation hazard. Contact with hot or live circuits could result in death or serious injury. Remove all rings, watches and other jewelry.

- 12 Remove the fasteners securing the terminal box cover to the top of the generator. Remove the cover.

⚠ CAUTION Burn hazard. Contact with hot engine components may cause severe burns. Use caution when working around a hot engine.



REV A

GENERATOR

- 13 Tag and disconnect the black, white, and green wires, that enter the terminal box, from the generator.

⚠ DANGER Electrocutation hazard. Exposure to high voltage electrical wires or electrical current will result in death or serious injury. Remove all rings, watches and other jewelry. Use extreme caution when working with high voltage electrical components.

- 14 Loosen the wiring clamp located on the back of the capacitor compartment of the generator. Pull the wiring out of the terminal box through the wiring clamp.
- 15 Use a lifting jack or similar device to support the rear of the engine. Do not apply any lifting pressure.
- 16 Remove the generator fan screens from both sides of the generator.
- 17 Remove the fasteners securing the generator to the engine flywheel.
- 18 Remove the fasteners securing the generator to the chassis.
- 19 Attach a lifting strap from an overhead crane or other suitable device to both lifting eyes on the generator. Support the generator. Do not apply any lifting pressure.
- 20 Remove the fasteners securing the generator to the engine bellhousing.
- 21 Remove the generator from the machine.

⚠ CAUTION Crushing hazard. The generator may become unbalanced and fall if not properly supported when removed from the machine.

How to Remove the Generator - Newage Generator Models

⚠ DANGER Electrocutation hazard. Exposure to high voltage electrical wires or electrical current will result in death or serious injury. Remove all rings, watches and other jewelry. Turn off all power when not needed for testing. Use extreme caution when working with high voltage electrical components.

Note: Be sure the engine has been turned off for at least 15 minutes before servicing the machine. Use a voltmeter to confirm there is no residual voltage in the capacitors.

- 1 Extend all four outriggers. Lower each outrigger until they make contact with the ground.
- 2 Raise the tower to a vertical position. Do not extend the tower or raise the light bar. Turn the machine off.
- 3 Open each cabinet door. Remove the hinge retaining fasteners from the cabinet top for each cabinet door.
- 4 Disconnect the gas struts from each cabinet door. Remove each door from the machine.
- 5 Locate the domelight mounted to the cabinet top above the engine. Remove the lens from the domelight. Remove the domelight mounting fasteners and set the domelight aside.
- 6 Locate the wiring for the limit switch located at the transport lock pin. Tag and disconnect the limit switch wiring from inside the engine compartment.
- 7 Remove the limit switch mounting fasteners and set the switch aside.
- 8 Remove the tower rest pad weldment fasteners. Remove the rest pad from the cabinet.
- 9 Support the cabinet top with a suitable lifting device.

GENERATOR

REV A

10 Remove all fasteners securing the cabinet top to the cabinet end panels. Carefully remove the cabinet top from the machine.

CAUTION Crushing hazard. The cabinet top may become unbalanced and fall if not properly supported when removed from the machine.

Models with Newage generators:

11 Disconnect the battery from the machine.

WARNING Electrocutation hazard. Contact with hot or live circuits could result in death or serious injury. Remove all rings, watches and other jewelry.

12 Remove the fasteners securing the terminal box cover to the top of the generator. Remove the cover.

CAUTION Burn hazard. Contact with hot engine components may cause severe burns. Use caution when working around a hot engine.

13 Tag and disconnect the black, white, and green wires, that enter the terminal box, from the generator.

DANGER Electrocutation hazard. Exposure to high voltage electrical wires or electrical current will result in death or serious injury. Remove all rings, watches and other jewelry. Use extreme caution when working with high voltage electrical components.

14 Loosen the wiring clamp located on the back of the capacitor compartment of the generator. Pull the wiring out of the terminal box through the wiring clamp.

15 Use a lifting jack or similar device to support the rear of the engine. Do not apply any lifting pressure.

16 Remove the generator fan screens from both sides of the generator.

Note: The generator fan screens cover the generator fan blades and are located between the generator and the engine bellhousing.

17 Remove the fasteners securing the generator to the engine flywheel.

18 Remove the fasteners securing the generator to the chassis.

19 Attach a lifting strap from an overhead crane or other suitable device to both lifting eyes on the generator. Support the generator. Do not apply any lifting pressure.

20 Remove the fasteners securing the generator to the engine bellhousing.

21 Remove the generator from the machine.

CAUTION Crushing hazard. The generator may become unbalanced and fall if not properly supported when removed from the machine.

Models with Leroy Somer generators:

11 Pull the cover off the top of the generator to access the wire harness where it connects to the generator.

12 Using an insulated conductor or a screwdriver with an insulated handle, discharge the capacitor by shorting across the capacitor terminals. Repeat for the second capacitor, if equipped.

DANGER Electrocutation hazard. Exposure to high voltage electrical wires or electrical current will result in death or serious injury. Remove all rings, watches and other jewelry. Use extreme caution when working with high voltage electrical components.

13 Tag and disconnect the wires at the top of the generator. Remove the cover.



Chassis Components

REV A

- 14 Tag and disconnect the ground wire from the generator mount.
 - 15 Use a lifting jack or similar device to support the rear of the engine. Do not apply any lifting pressure.
 - 16 Remove the generator fan screen from the generator.
- Note: The generator fan screen covers the generator fan blades and is located between the generator and the engine bellhousing.
- 17 Remove the fasteners securing the generator to the engine flywheel.
 - 18 Remove the fasteners securing the generator to the chassis.
 - 19 Attach a lifting strap from an overhead crane to the generator. Support the generator. Do not apply any lifting pressure.
 - 20 Remove the fasteners securing the generator to the engine bellhousing.
 - 21 Remove the generator from the machine.

CAUTION Crushing hazard. The generator will fall if not properly supported when removed from the machine.

7-1

Ground Controls

How to Program the Engine Start Timer (machines with auto start option)

The timer is used to automatically start the engine and turn on the lights at a preset time.

- 1 Move the engine start switch to timed start.
- 2 On the timer, move the mode switch (upper left switch) to AUTO and the set switch (upper right switch) to RUN.

- 3 Using the tip of a pencil or pen, press the Reset button (R). A blinking display will show 0:00 for the time and an arrow under the day 7 (for Sunday).
- 4 Move the set switch to the left (clock icon) to set the present day and time.
- 5 A default time of AM 12:00 will appear on the display screen.
- 6 Press the day button (1..7) repeatedly until the arrow points to the actual day of the week.
- 7 Press the hour button (h) repeatedly until the actual hour of the day is displayed.
- 8 Press the minute button (m) repeatedly until the minute of the present hour is displayed.
- 9 Move the Set switch to the program position (P) to set the desired stop and start time. A default time of AM 12:00 will appear. A small 1 will appear to the right of the time with a lamp symbol above it.
- 10 Use the day, hour and minute buttons to set the timer to the desired start day and time.
- 11 Press the program button (P) to set the timer for the desired shut-off time. AM 12:00 will appear in the display with a small 2 to the right.

Note: The lamp symbol will not appear above the 2.

- 12 Use the day, hour and minute buttons to set the timer to the desired shut-off day and time.
- 13 Move the set switch to RUN.

CHASSIS COMPONENTS

REV A

7-2 Light Ballast

How to Check a Ballast Capacitor

⚠ DANGER Electrocutation hazard. Exposure to high voltage electrical wires or electrical current will result in death or serious injury. Remove all rings, watches and other jewelry. Use extreme caution when working with high voltage electrical components.

⚠ WARNING Electrocutation hazard. Attempting to service the machine before the capacitors are fully discharged could result in death or serious injury.

Note: Be sure the engine has been turned off for at least 15 minutes before servicing the machine. Use a voltmeter to confirm there is no residual voltage in the capacitors.

Note: This procedure is only for the capacitors which are attached to the lighting ballasts. To test a generator capacitor, see 6-1, *How to Check a Generator Capacitor*.

- 1 Open both cabinet doors and locate the light ballast boxes on each side of the machine.
- 2 Choose a ballast box. Tag and disconnect the wire harness connector from the ballast box.

Note: If the ballast capacitor to be tested is located under another ballast box, the top ballast box will need to be removed first.

- 3 Remove the ballast box cover fasteners.
- 4 Using an insulated conductor or a screwdriver with an insulated handle, discharge the capacitor by shorting across the capacitor terminals.

⚠ DANGER Electrocutation hazard. Exposure to high voltage electrical wires or electrical current will result in death or serious injury. Remove all rings, watches and other jewelry. Use extreme caution when working with high voltage electrical components.

- 5 With an ohmmeter set to its highest resistance scale, connect the ohmmeter leads to the capacitor terminals and observe the reading on the meter. Then, reverse the connections and observe the reading on the meter.

⦿ Result: The meter indicates a resistance which then gradually decreases. The capacitor is working.

✗ Result: The meter indicates a very high resistance which does not decrease. The capacitor is faulty and should be replaced.

✗ Result: The meter indicates a very low resistance which does not increase. The capacitor is faulty and should be replaced.

Probable causes of capacitor failure:

- Normal end-of-life failure.
- Overheated due to light fixture heat or high ambient temperature.
- Incorrect capacitor voltage rating.
- Capacitor becomes loose in ballast box.



REV A

CHASSIS COMPONENTS

7-3**Fuel Tank****How to Remove a Fuel Tank**

- 1 Open both cabinet doors.
- 2 Remove the fuel filler cap from the tank. Using an approved hand-operated pump, drain the fuel tank into a container of suitable capacity. Refer to Section 2, *Specifications*.

▲ DANGER Explosion and fire hazard. Engine fuels are combustible. Perform this procedure in an open, well-ventilated area away from heaters, sparks, flames and lighted tobacco. Always have an approved fire extinguisher within easy reach.

▲ DANGER Explosion and fire hazard. When transferring fuel, connect a grounding wire between the machine and pump or container.

NOTICE Be sure to only use a hand-operated pump suitable for use with diesel fuel.

Note: If your machine is equipped with dual fuel tanks, repeat this procedure beginning with step 2 for the other fuel tank.

- 3 Tag, disconnect and plug the fuel hoses from the fuel tank. Clean up any fuel that may have spilled.

Models without fuel containment option:

- 4 Support the fuel tank support weldment at each end using lifting jacks and blocks. Do not apply any lifting pressure. Do not directly support the fuel tank.

NOTICE Component damage hazard. The fuel tank is plastic and may become damaged if the lifting jacks are in direct contact with the plastic tank.

- 5 Remove the fasteners securing the fuel tank support weldment to the chassis.
- 6 Carefully lower the fuel tank out of the chassis and remove it from the machine.

NOTICE Component damage hazard. The fuel tank is plastic and may become damaged if allowed to fall.

Note: It may be necessary to lower the outriggers to the ground and raise the machine using the outriggers to obtain adequate clearance to completely remove the fuel tank from the machine.

Note: Clean the fuel tank and inspect for cracks and other damage before installing it onto the machine.

CHASSIS COMPONENTS

REV A

Models with fuel containment option:

- 4 Support the fuel tank containment weldment at each end using lifting jacks and blocks. Do not apply any lifting pressure.

NOTICE Component damage hazard. The fuel tank is plastic and may become damaged if the lifting jacks are in direct contact with the plastic tank.

- 5 Remove the fasteners securing the fuel tank containment weldment to the chassis.
- 6 Carefully lower the fuel tank out of the chassis and remove it from the machine. Remove the fuel tank from the fuel containment weldment.

NOTICE Component damage hazard. The fuel tank is plastic and may become damaged if allowed to fall.

Note: It may be necessary to lower the outriggers to the ground and raise the machine using the outriggers to obtain adequate clearance to completely remove the fuel tank.

Note: Clean the fuel tank and inspect for cracks and other damage before installing it onto the machine.

REV A

CHASSIS COMPONENTS

8-1 Function Manifold Components

The function manifold is located next to the hydraulic power unit inside the engine compartment.

Index No.	Description	Schematic Item	Function	Torque
1	Solenoid valve, 3 position 4 way	E	Light bar up/down	25 ft-lbs / 34 Nm
2	Solenoid valve, 3 position 4 way	C	Tower extend/retract	25 ft-lbs / 34 Nm
3	Solenoid valve, 3 position 4 way	B	Tower up/down	25 ft-lbs / 34 Nm
4	Relief valve - Bi-directional, 1200 psi / 82.7 bar	H	Tower rotate left/right	20 ft-lbs / 27 Nm
5	Solenoid valve, 3 position 4 way	G	Tower rotate left/right	25 ft-lbs / 34 Nm
6	Priority flow regulator valve, 0.2 gpm / 0.76 L/min	D	Light bar up/down circuit	20 ft-lbs / 27 Nm
7	Orifice plug, 0.025 inch / 0.64 mm	F	Tower rotate circuit	

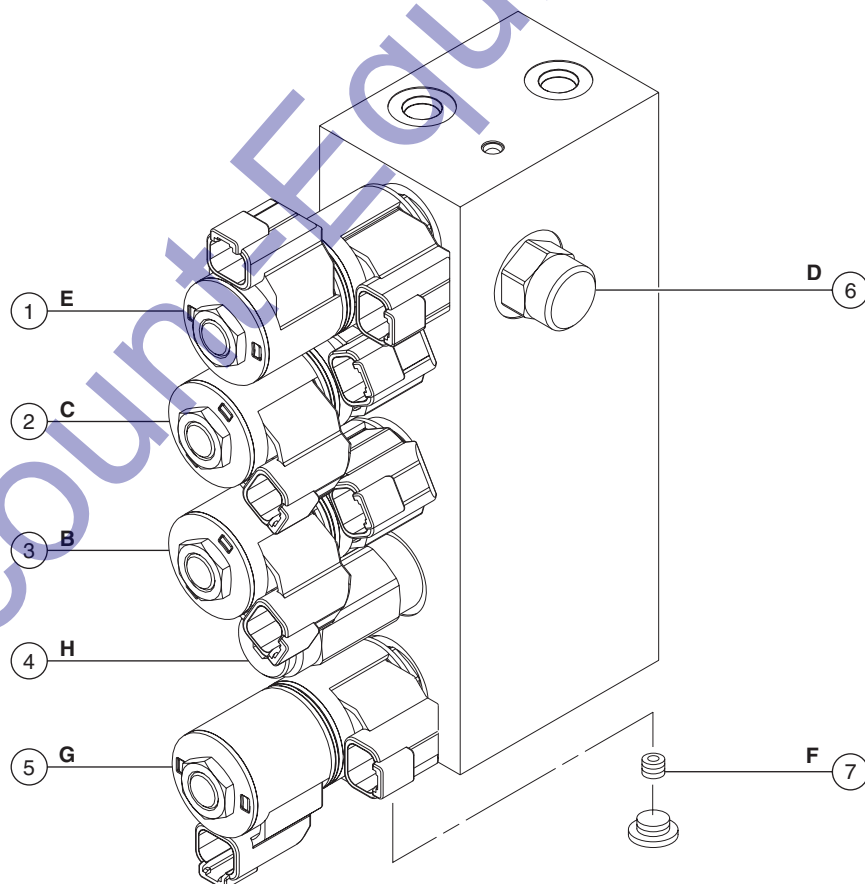

CHASSIS COMPONENTS

REV A

8-2 Valve Adjustments - Function Manifold

How to Adjust the Tower Rotate Relief Valve

Note: When removing a hose assembly or fitting, the O-ring on the fitting and/or hose end must be replaced and then torqued to specification during installation. Refer to Section 2, *Hydraulic Hose and Fitting Torque Specifications*.

Note: Perform this procedure with the tower in the stowed position.

- 1 Disconnect and plug the hydraulic hose from the "P" port at the function manifold.

⚠WARNING Bodily injury hazard. Spraying hydraulic oil can penetrate and burn skin. Loosen hydraulic connections very slowly to allow the oil pressure to dissipate gradually. Do not allow oil to squirt or spray.

- 2 Connect a 0 to 5000 psi / 0 to 350 bar pressure gauge to the "P" port of the function manifold using a tee fitting. Install the hose to the tee fitting.
- 3 Activate and hold the tower rotate toggle switch in either direction.
- 4 Observe the pressure reading on the pressure gauge. Refer to Section 2, *Specifications*.

- 5 Use a wrench to hold the relief valve and remove the cap (item H).
- 6 Adjust the internal hex socket. Turn it clockwise to increase the pressure or counterclockwise to decrease the pressure. Install the relief valve cap.

NOTICE Component damage hazard. Do not adjust the relief valve higher than specified.

- 7 Repeat steps 3 through 6 and recheck relief valve pressure.
- 8 Remove the pressure gauge.



Troubleshooting



Observe and Obey:

- ☑ Troubleshooting and repair procedures shall be completed by a person trained and qualified on the repair of this machine.
- ☑ Immediately tag and remove from service a damaged or malfunctioning machine.
- ☑ Repair any machine damage or malfunction before operating the machine.
- ☑ Unless otherwise specified, perform each repair procedure with the machine in the following configuration:
 - Machine parked on a firm, level surface.
 - Wheels chocked.
 - Toggle switch in off position.
 - All circuit breakers are in the off position.

Before Troubleshooting:

- ☑ Read, understand and obey the safety rules and operating instructions in the appropriate operator's manual on your machine.
- ☑ Be sure that all necessary tools and test equipment are available and ready for use.
- ☑ Be aware of the following hazards and follow generally accepted safe workshop practices.
- ☑ Use only a voltmeter with insulated probes rated at a minimum of 600V AC.
- ☑ Allow lamps to cool before opening the fixtures.

⚠ DANGER

Electrocution hazard. Exposure to high voltage electrical wires or electrical current will result in death or serious injury. Remove all rings, watches and other jewelry. Turn off all power when not needed for testing. Use extreme caution when working with high voltage electrical components.

⚠ DANGER

Electrocution hazard. Attempting to service the machine before the capacitors are fully discharged will result in death or serious injury.

⚠ WARNING

Electrocution hazard. Exposure to electrically charged circuits could result in death or serious injury. Remove all rings, watches and other jewelry.

⚠ CAUTION

Burn hazard. Contact with hot engine components may cause severe burns. Use caution when working around a hot engine.

Troubleshooting Guide

The engine/generator set is tested and set at the factory for proper operation in the field. These units should never require additional adjustments in the field. If needed, adjustments should only be made by a qualified service technician, otherwise the manufacturer's warranty may become void.

TROUBLE	POSSIBLE CAUSE	REMEDY
1. Boom will not rise to the operating position.	a. Travel lock pin is in place	a. Remove travel lock pin
	b. Defective cable or pulley	b. Have a trained mechanic examine and repair as needed
2. Boom will not telescope.	a. Problem with hydraulics	a. Trouble shoot hydraulic system and service as needed
	b. Broken cable or pulley	b. Have a trained mechanic examine and replace as needed
	c. Extend cylinder damaged	c. Inspect extend cylinder
3. Engine will not turn over	a. Dead battery	a. Check the battery voltage or loose cables
	b. Bad starter	b. Check voltage at starter and replace as needed
4. Engine turns over but will not start	a. Empty fuel tank	a. Fill tank with #2 diesel fuel
	b. Clogged fuel lines or filter	b. Check and clean the fuel system as needed
	c. Leaking fuel lines or a loss of prime	c. Replace any leaking fuel lines and tighten connections
	d. Heater elements burned out	d. Replace heater elements
	e. Fuel line solenoid is not open	e. Replace fuel line solenoid
5. Engine runs rough	a. Clogged or leaking fuel system	a. Replace fuel lines, tighten all connections, inspect the pickup tube and inspect the fuel filter
	b. Clogged exhaust system	b. Clear the exhaust system
	c. Clogged air filter	c. Clear air filter
	d. Clogged or stuck fuel injectors	d. Have a trained mechanic examine
	e. Valve clearances are out of adjustment or the valve spring may be damaged	e. Have a trained mechanic examine
	f. Defective governor or fuel pump	f. Have a trained mechanic examine

REV A

TROUBLESHOOTING

TROUBLE	POSSIBLE CAUSE	REMEDY
6.Engine runs but produces a dense smoke	a.Crankcase oil level is too high	a.Drain oil to its proper level
	b.Low compression	b.Have a trained mechanic inspect for broken or seized rings. Inspect valve clearances
7.Engine overheats	a.Blocked cooling air intakes	a.Inspect the front and rear intakes and clear as needed
	b.Low coolant levels	b.Replace the coolant with a 50% water/coolant solution
	c.Radiator fins have become clogged	c.Clear the radiator fins
	d.Fan belt is loose	d.Tighten fan belt
	e.Thermostat is bad	e.Check/Replace thermostat
8.Engine runs but the battery voltage is low	a.Alternator has failed	a.Have a trained mechanic inspect the alternator
9.Engine runs but the lights will not operate	a.Circuit breakers are tripped	a.Reset the circuit breaker
	b.Loose connections in the wiring system	b.Have a trained electrician inspect the ballast box wiring system
	c.Burned out bulb	c.Replace the bulbs as needed
	d.Defective generator capacitor (Leroy Somers/Marathon Generator)	d.Have a trained electrician inspect the capacitor
	e.Defective AC generator	e.Have a trained electrician inspect the generator
	f.Engine speed is too low	f.Have a trained mechanic inspect the engine speed and reset to 1800rpm @ 60hz
	g.Defective ballast and capacitors	g.Have a trained electrician inspect the ballast and capacitors
10.Unusual noise coming from the generator	a.The generator has a defective bearing or damaged fan blade	a.Have a trained electrician inspect the generator
11.Lamp will not start	a.Lamp loose in socket	a.Inspect lamp base to see if there is arcing at center contact button. Tighten lamp. Check socket for damage. Replace if needed.
	b.Floodlight plugs not tight	b.Check plug and receptacle. Tighten if needed. Make sure power is off.
	c.Defective ballast	c.Interchange ballast plugs. If lamp starts, replace ballast. Check for swollen capacitors, charred wiring, core and coil, or other signs of excessive heat.
	d.Low voltage	d.Check line voltage at ballast input. Voltage should be within 10% of rating when operating at normal load. Increase supply voltage or remove external load.

TROUBLESHOOTING

REV A

TROUBLE	POSSIBLE CAUSE	REMEDY
11. Lamp will not start	e. Improper ballast	e. The ballast name plate data should agree with the line voltage and lamp used. If not, replace the ballast.
	f. Lamp has been operating; cool down time insufficient	f. Switch off breaker and allow lamp to cool.
12. Lamp starts slowly (arc does not strike when switch is first turned on)	a. Defective lamp	a. Lamp may glow for an extended period of time. Replace after checking voltage and ballast
13. Circuit breaker trips on lamp startup	a. Short circuit or ground	a. Check wiring against diagram. inspect for shorts or ground. Fix as needed.
14. Lamp light output low	a. Normal lamp depreciation	a. Replace lamp
	b. Dirty lamp or fixture	b. Clean lamp and fixture
	c. Defective ballast	c. Interchange ballast plugs. If lamp starts, replace ballast. Check for swollen capacitors, charred wiring, core and coil, or other signs of excessive heat.
	d. Wrong voltage	d. Check line voltage at ballast input. Voltage should be within 10% of rating when operating at normal load. Check wiring connections for voltage loss. Check socket contact point.
	e. Improper ballast	e. Check ballast name plate against lamp data
15. Lamp colors different	a. Normal lamp depreciation	a. Replace lamp
	b. Dirty lamp or fixture	b. Clean lamp and fixture
	c. Wrong lamp	c. Check data on lamps and replace as needed.
16. Arc tube discolored or swollen	a. Over voltage from power supply	a. Check voltage at ballast, for current or voltage surges, for shorted capacitors and replace as needed
	b. Improper ballast	b. Check ballast name plate against lamp data
17. Short lamp life	a. Lamp damaged	a. Check for outer bulb cracks, cracks where lamp meets base, and for broken arc tube or loose metal parts. Replace as needed.
	b. Improper ballast	b. Check ballast name plate against lamp data
18. Lamp flickers or goes out-intermittent or cycling	a. Improper Ballast	a. Check ballast name plate against lamp data
	b. New lamp	b. Under certain conditions new lamps may "cycle". Usually after 3 tries to start at 30 to 60 second intervals, lamp will stabilize and operate normal

TROUBLE	POSSIBLE CAUSE	REMEDY
18. Lamp flickers or goes out-intermittent or cycling	c. Defective capacitor	c. Replace capacitor
	d. Defective lamp	d. Replace lamp
	e. High spike ballast	e. Ballast produces high spike current. Measure with oscilloscope. Replace ballast as required.

IF YOU FEEL AN ELECTRIC SHOCK AT ANY TIME WHILE OPERATING THIS UNIT, SHUT IT DOWN IMMEDIATELY! HAVE THE UNIT INSPECTED BY A TRAINED ELECTRICIAN.

THIS ENGINE/GENERATOR SET IS FACTORY INSTALLED, TESTED, AND SET FOR FIELD OPERATION. ANY DAMAGE TO THE ENGINE OR GENERATOR UNITS OCCURRING AFTER ADJUSTMENTS ARE MADE IN THE FIELD BY UNAUTHORIZED PERSONNEL WILL NOT BE COVERED BY YOUR MANUFACTURER'S WARRANTY AND WILL ALSO VOID THE MANUFACTURER'S WARRANTY ON THIS PARTICULAR UNIT. IF YOU CAN NOT REACH YOUR LOCAL DEALER, CONTACT THE FACTORY SERVICE MANAGER TOLL FREE AT 1-800-433-3026.

Light Fixture Troubleshooting



DO NOT OPEN FIXTURES WHILE LIGHT CIRCUIT BREAKER IS "ON". ALLOW LAMP TO COOL BEFORE TOUCHING.

****TAKE EXTRA PRECAUTIONS WHEN TROUBLESHOOTING ELECTRICAL PROBLEMS****

- A. Only use a voltmeter with two well-insulated pin probes rated for 600 volts.
- B. Treat all conductors as potentially hot.
- C. Proceed through circuits systematically, operating only one section at a time.
- D. Before disconnecting ballast, turn off circuit breaker and wait 30 seconds for capacitor to discharge.
- E. If all the lights are out and all the ballasts are receiving power, suspect burned out power cable.

Schematics

REV A



Observe and Obey:

- ☑ Troubleshooting and repair procedures shall be completed by a person trained and qualified on the repair of this machine.
- ☑ Immediately tag and remove from service a damaged or malfunctioning machine.
- ☑ Repair any machine damage or malfunction before operating the machine.

Before Troubleshooting:

- ☑ Read, understand and obey the safety rules and operating instructions in the appropriate Operator's Manual on your machine.
- ☑ Be sure that all necessary tools and test equipment are available and ready for use.

About This Section

There are two groups of schematics in this section. An illustration legend precedes each group of drawings.

Electrical Schematics

⚠WARNING Electrocution hazard. Contact with electrically charged circuits could result in death or serious injury. Remove all rings, watches and other jewelry.

Hydraulic Schematics

⚠WARNING Bodily injury hazard. Spraying hydraulic oil can penetrate and burn skin. Loosen hydraulic connections very slowly to allow the oil pressure to dissipate gradually. Do not allow oil to squirt or spray.

General Repair Process

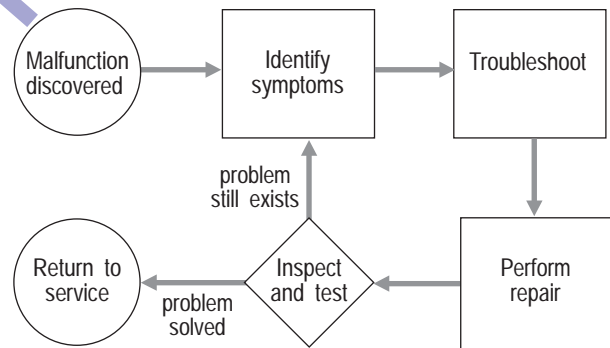

Electrical Symbols Legend

REV A

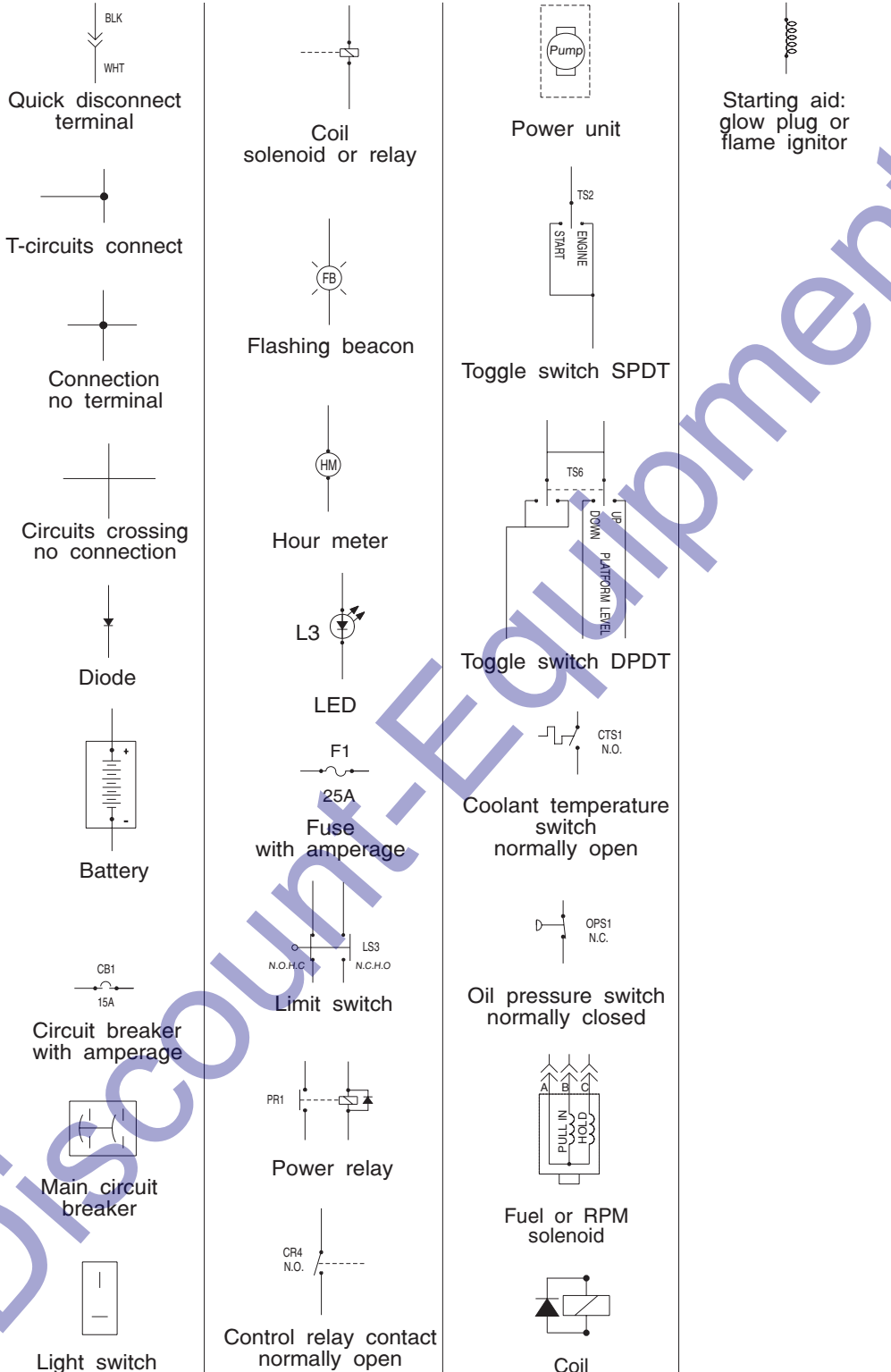

Hydraulic Symbols Legend

REV A

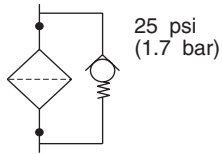

Filter with bypass valve relief setting



Pump fixed displacement



Pump prime mover (engine or motor)

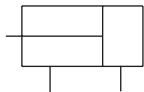

Double acting cylinder



Orifice with size



Check valve

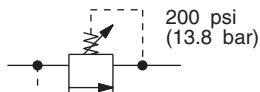

Relief valve with pressure setting

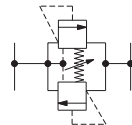

Cross-relief valve

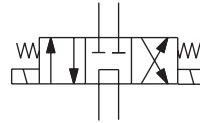

Solenoid operated 3 position, 4 way, directional valve

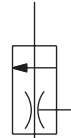

Priority flow regulator valve

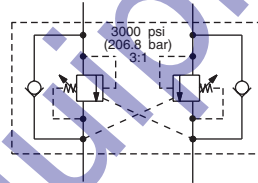

Counterbalance valve with pressure and pilot ratio

Electrical Schematic - Machine Functions

REV A

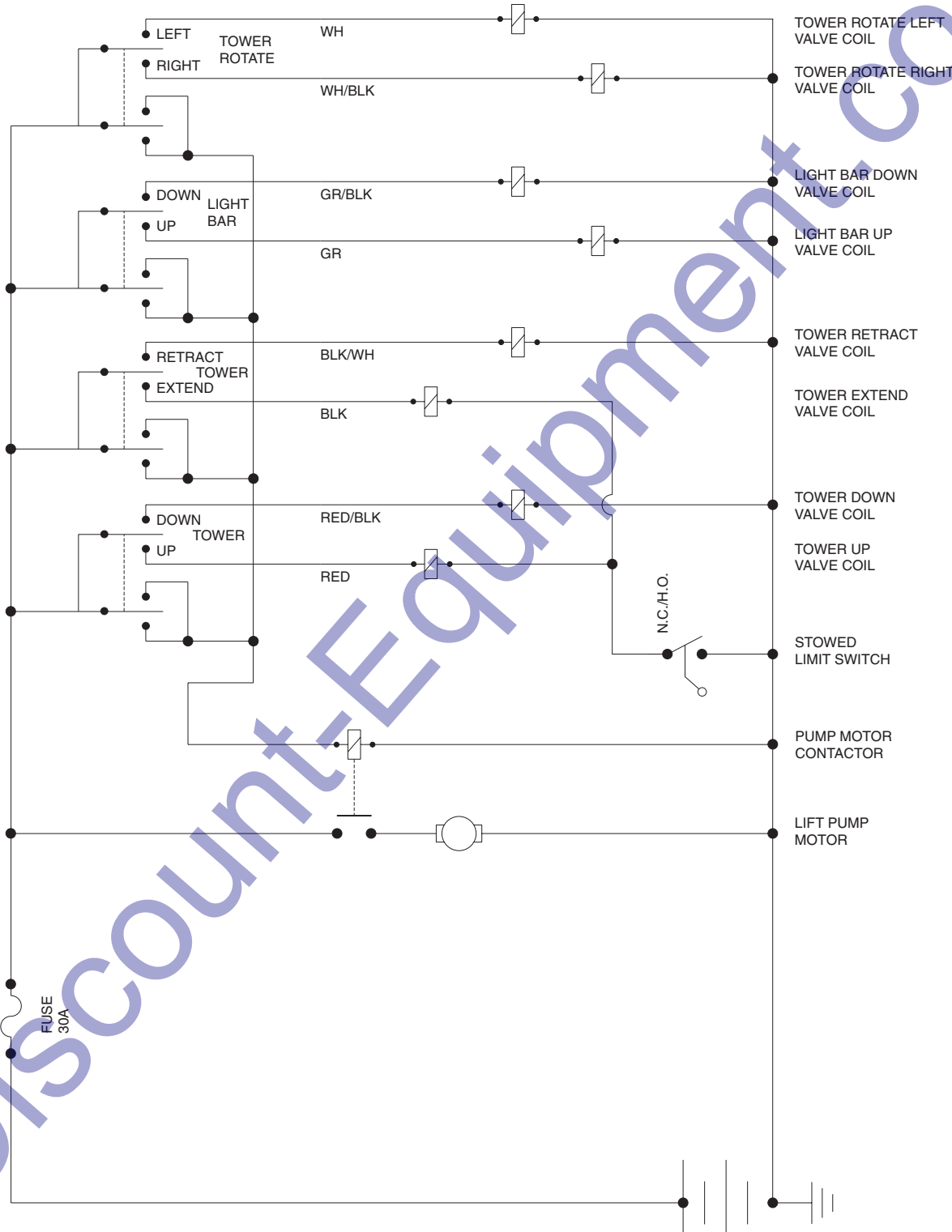

DC Electrical Schematic - Control Box and Engine Isuzu Models

REV A

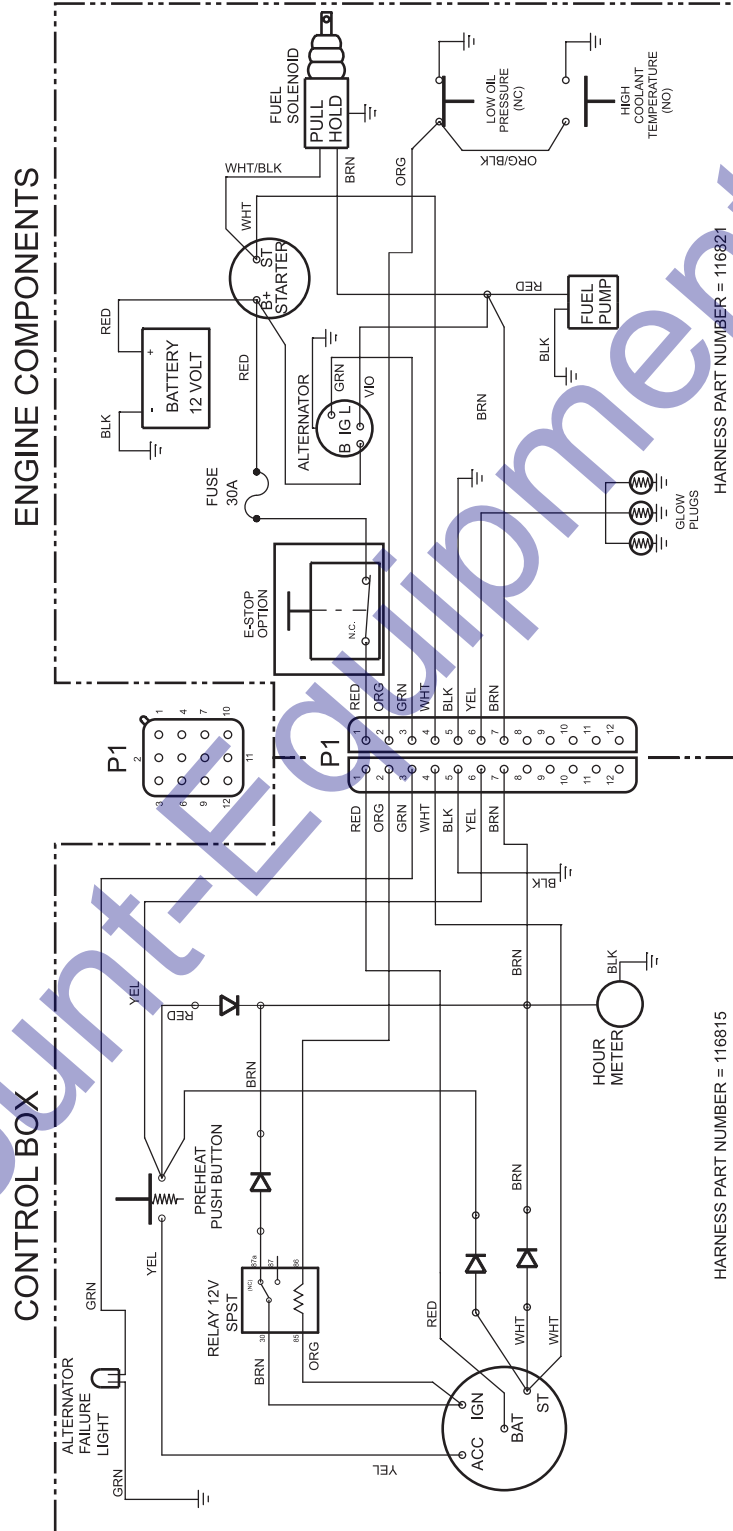

DC Electrical Schematic - Control Box and Engine
Kubota Models

REV A

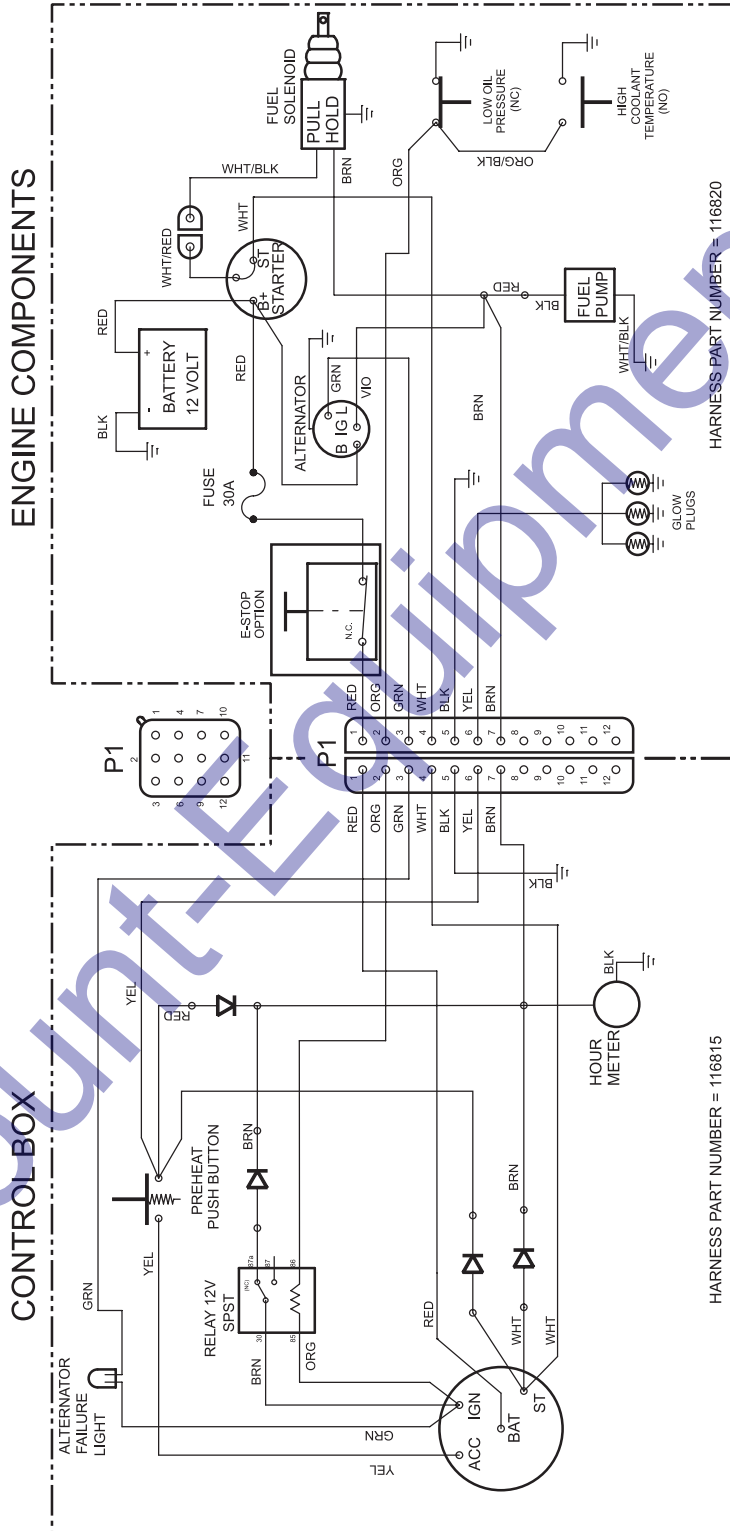

DC Electrical Schematic - Control Box and Engine with Autostart Option

REV A

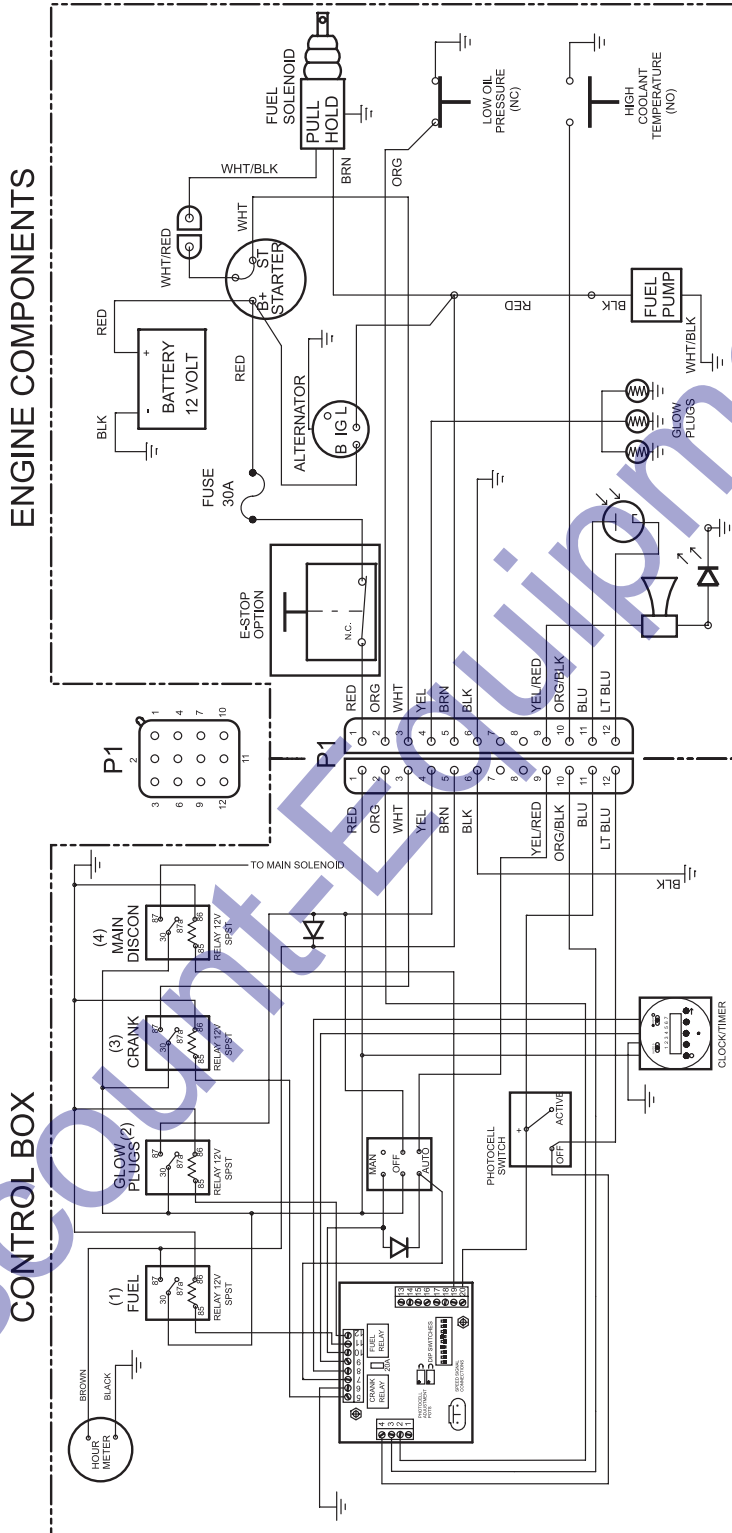

KUBOTA HARNESS PART NUMBER = 116823
ISUZU HARNESS PART NUMBER = 116829

KUBOTA HARNESS PART NUMBER = 116823

DYNAGEN POSITION LAYOUT

1	OPEN
2	LOW OIL PRESSURE
3	HIGH COOLANT TEMP
4	PHOTOCELL
5	STARTER OUTPUT (3)
6	GROUND
7	AUTOSTART
8	TIMER CONTACT
9	TIMER CONTACT
10	MANUAL START
11	FUEL OUTPUT (1)
12	PREHEAT OUTPUT (2)
13	OPEN
14	OPEN
15	OPEN
16	OPEN
17	OPEN
18	OPEN
19	MAIN DISCON OUTPUT (4)
20	GROUND

AC Electrical Schematic - Standard Models with 4 Lights

REV A

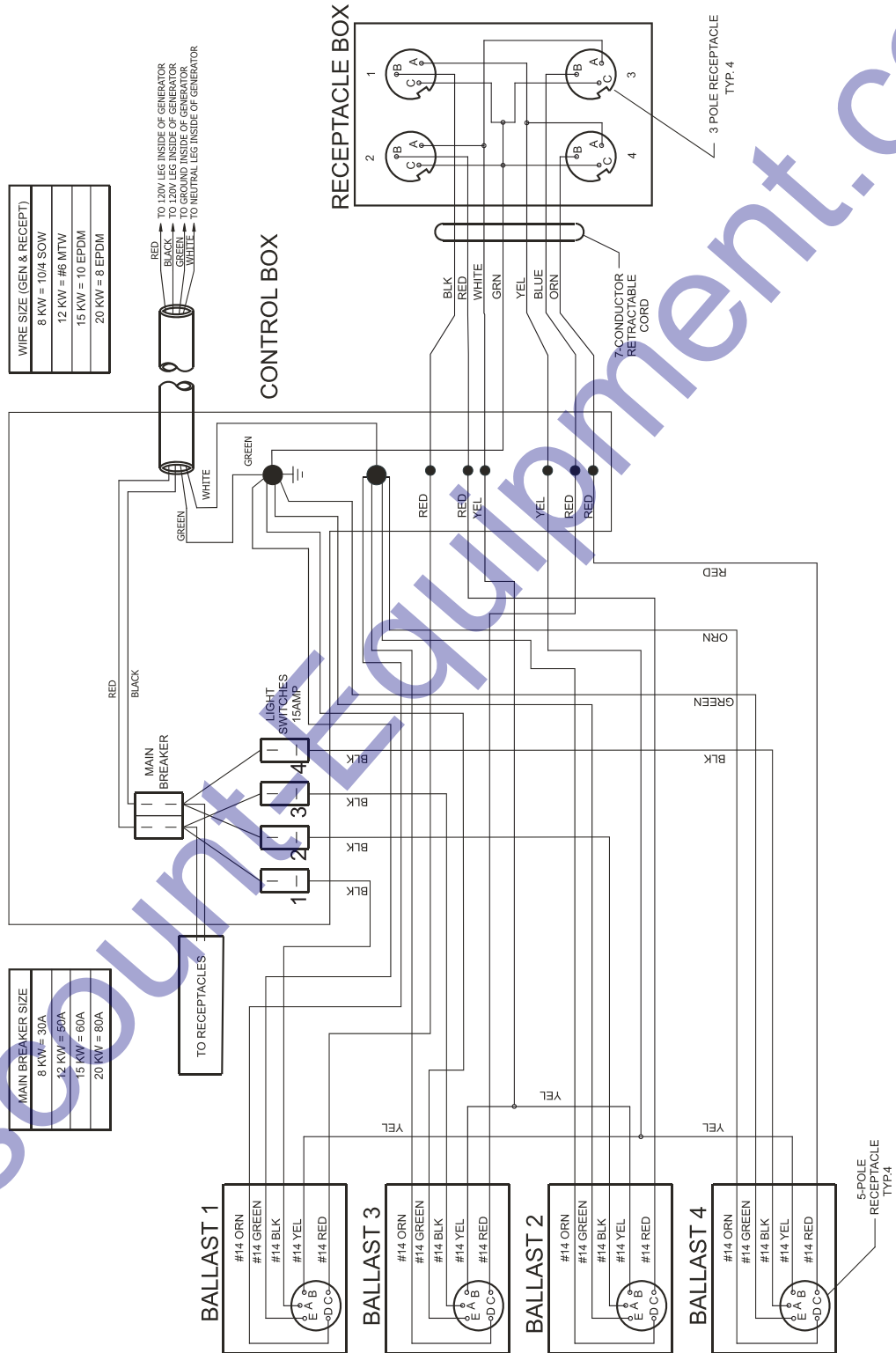

AC Electrical Schematic - Standard Models with 6 Lights

REV A

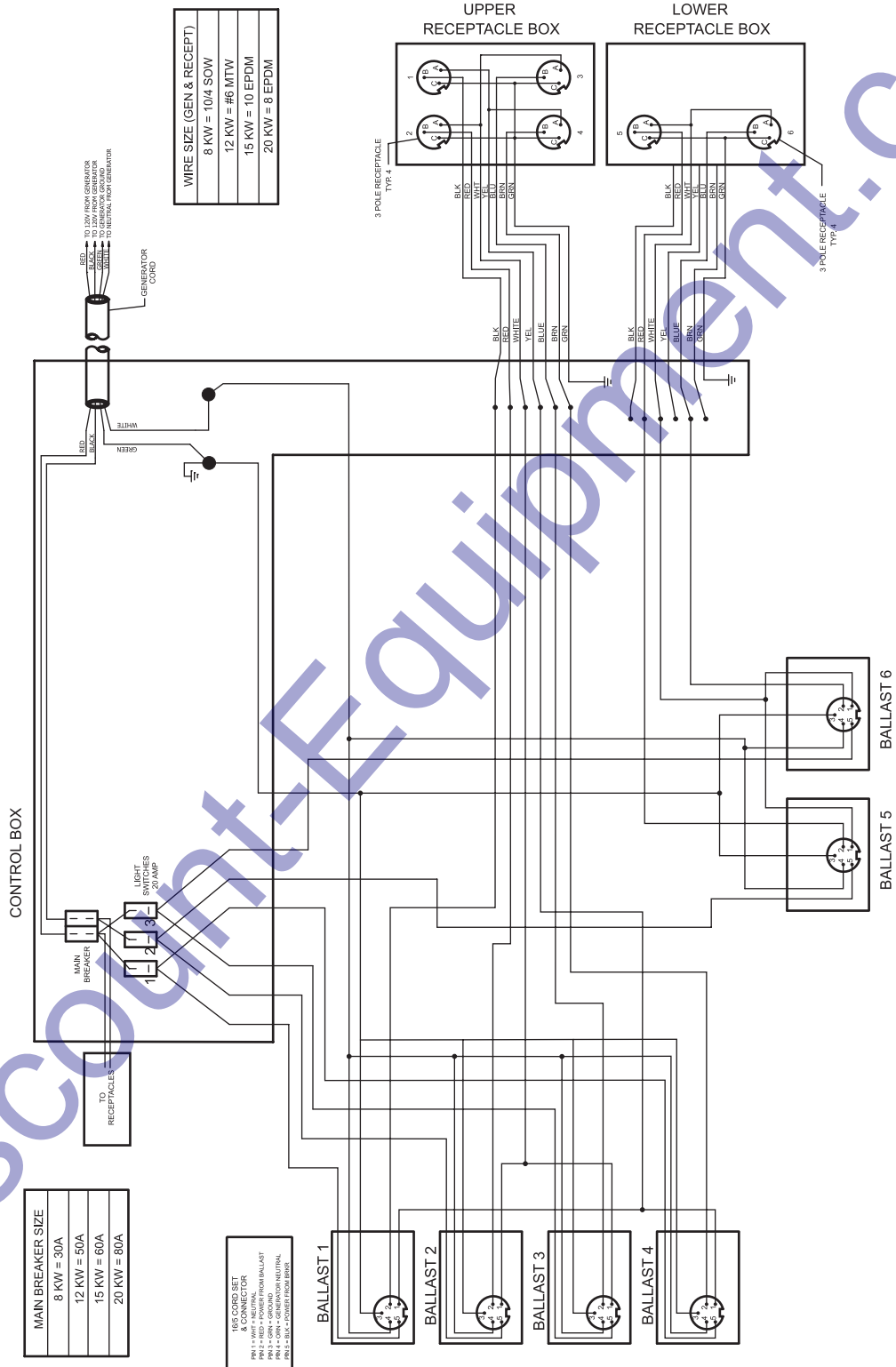

**AC Electrical Schematic -
Standard Models with 8 Lights**

REV A

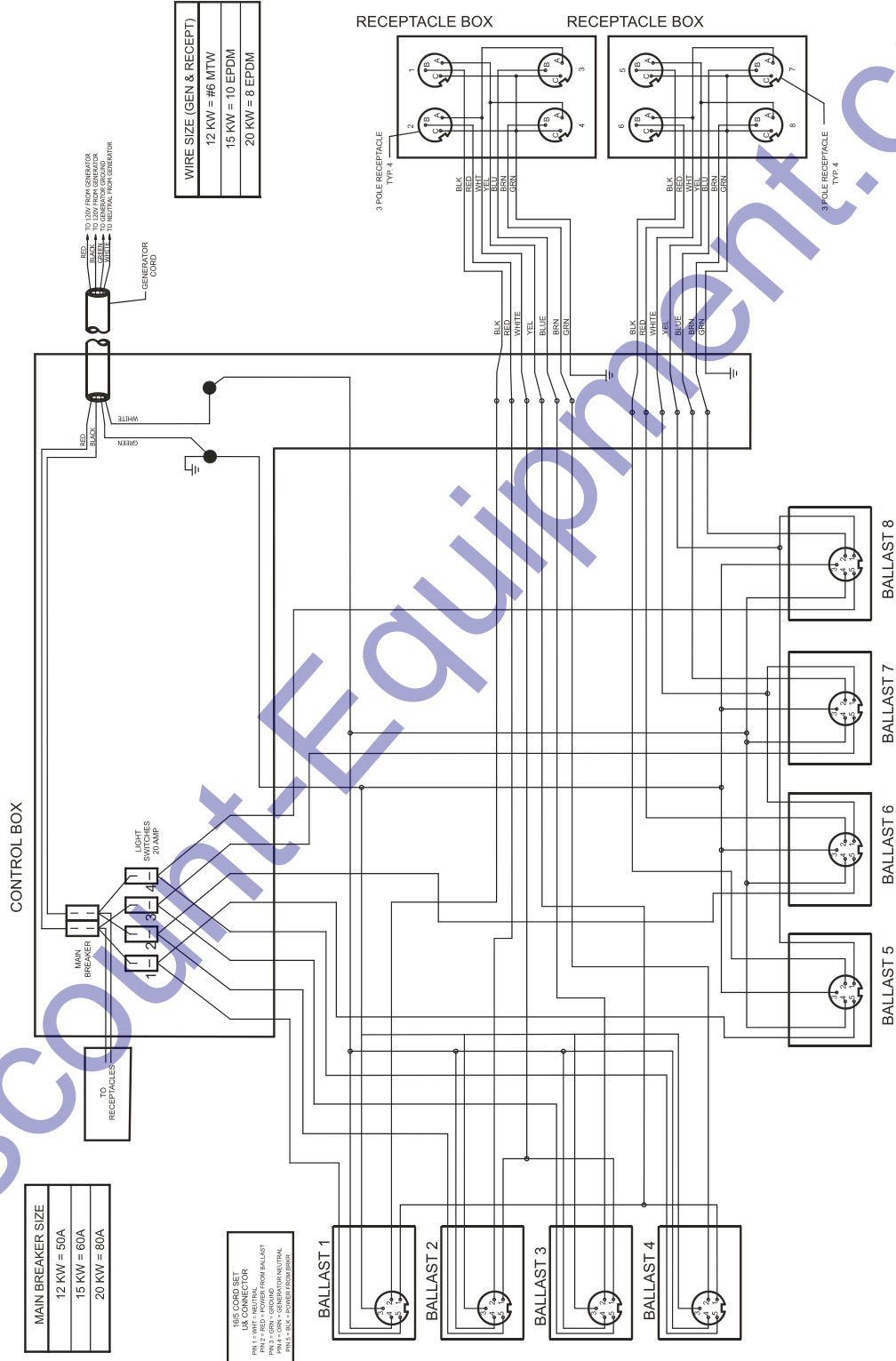

DiscoveryEquipment.com

AC Electrical Schematic - Autostart Models with 6 Lights

REV A

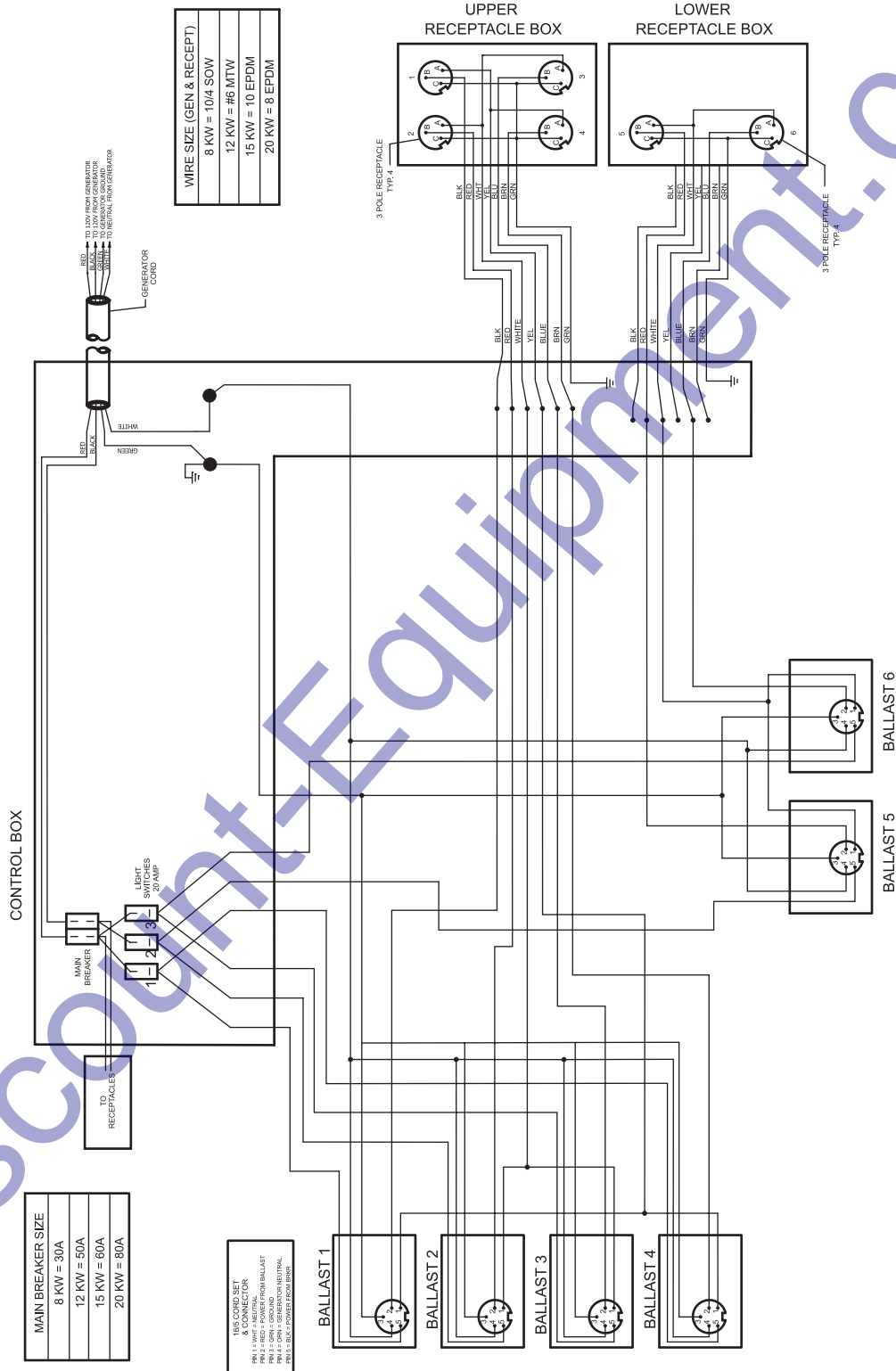



AC Electrical Schematic - Autostart Models with 8 Lights

REV A

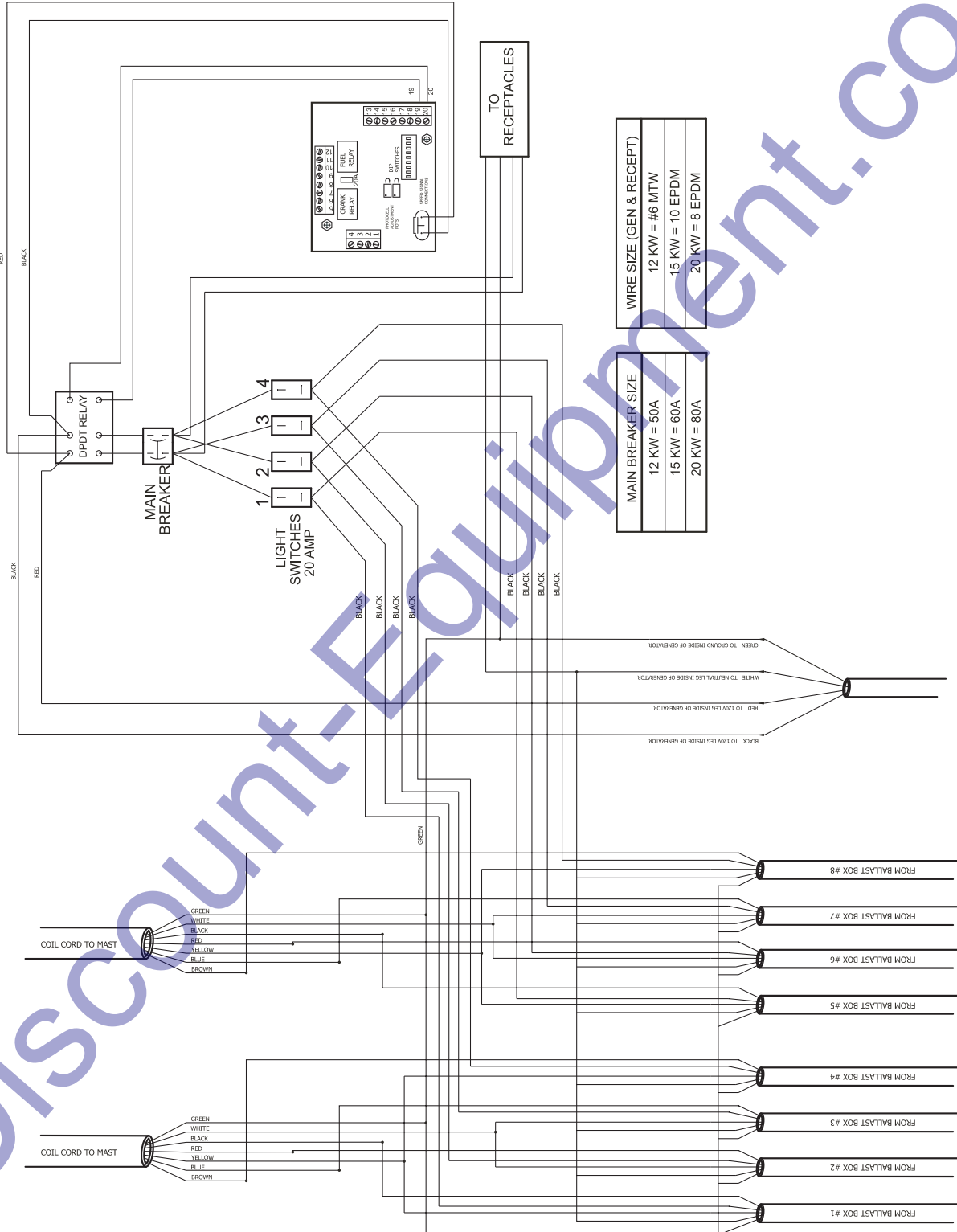

WIRE SIZE (GEN & RECEPT)	
12 KW = #6 MTW	
15 KW = 10 EPDM	
20 KW = 8 EPDM	

MAIN BREAKER SIZE	
12 KW = 50A	
15 KW = 60A	
20 KW = 80A	

Receptacle Wiring Diagrams

REV A

Standard Receptacle Package

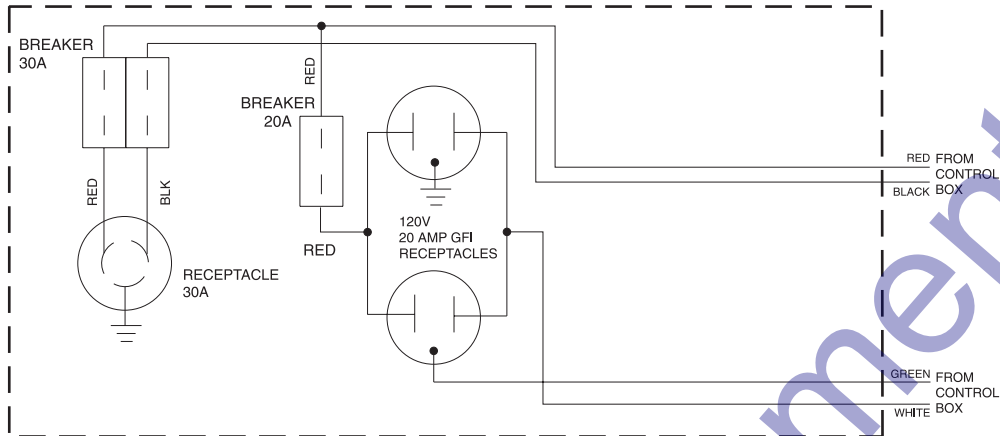

Extra GFCI Receptacle Package

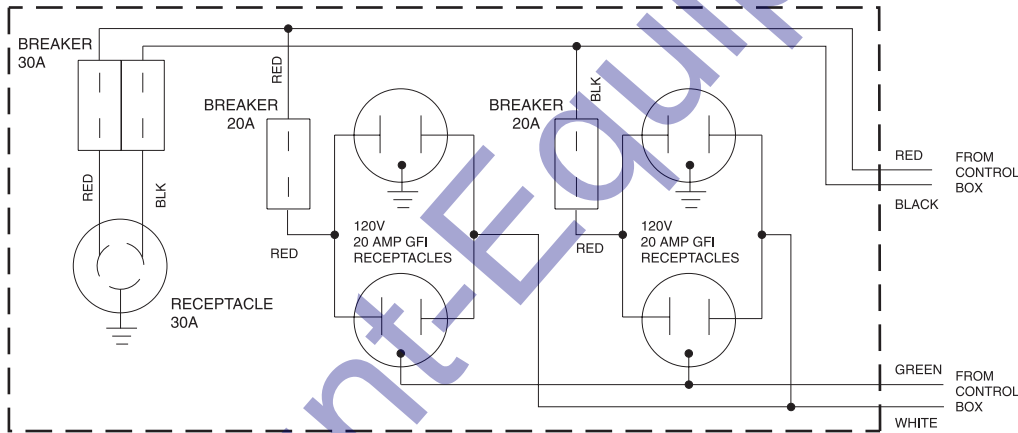

Enhanced Receptacle Package

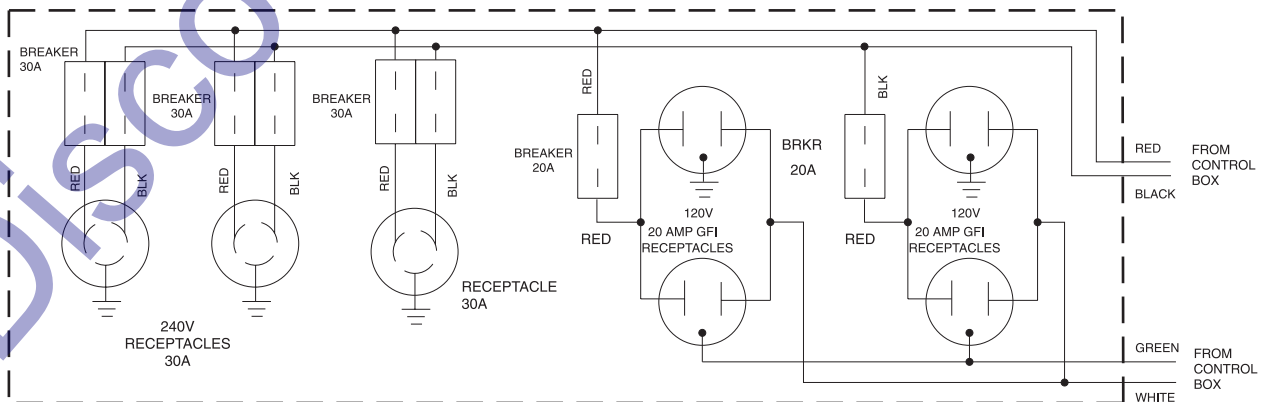

Hydraulic Schematic

REV A

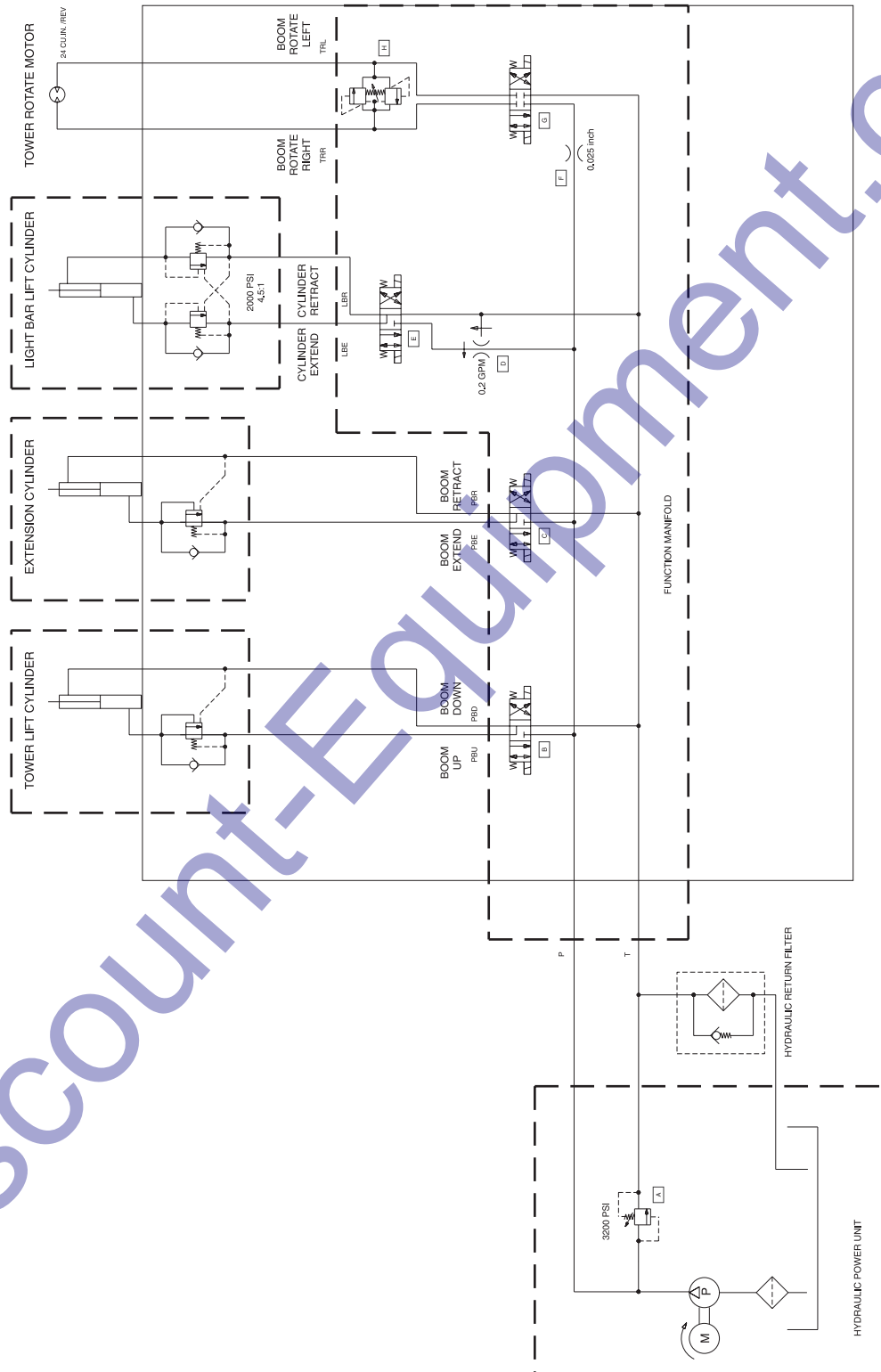

Discount-Equipment.com

