

TEREX®

Operator's Manual

AL4

AL5

AL5 with tier 4 option

ANSI/CSA
North America
South America
Asia

with
Maintenance
Information

First Edition
Third Printing
Part No. 229100

Discount-Equipment.com

Discount Equipment

Discount-Equipment.com is your online resource for commercial and industrial quality parts and equipment sales.

Locations:

Florida (West Palm Beach): [561-964-4949](tel:561-964-4949)

Outside Florida TOLL FREE: [877-690-3101](tel:877-690-3101)

Need parts? Check out our website at www.discount-equipment.com

Can't find what you need?

Click on this link: <http://www.discount-equipment.com/category/5443-parts/> and fill out the request form.

Please have the machine model and serial number available in order to help us get you the correct parts. One of our experienced staff members will get back to you with a quote for the right part that your machine needs.

We sell worldwide for the brands: Genie, Terex, JLG, MultiQuip, Mayco, Toro/Stone, Diamond Products, Magnum, Airman, Mustang, Power Blanket, Nifty Lift, Atlas Copco, Chicago Pneumatic, Allmand Brothers, Essick, Miller Spreader, Skyjack, Lull, Skytrak, Tsurumi, Husquvarna/Target, Whiteman-Concrete/Mortar, Stow-Concrete/Mortar, Baldor, Wacker, Sakai, Snorkel, Upright, Mi-T-M, Sullair, Neal, Basic, Dynapac, MBW, Weber, Bartell, Bennar Newman, Haulotte, Ditch Runner, Blaw-Knox, Himoina, Best, Buddy, Crown, Edco, Wyco, Bomag, Laymor, Terremite, Barreto, EZ Trench, Takeuchi, Basic, Bil-Jax, Curtis, Gehl, Heli, Honda, ICS/PowerGrit, Puckett, Waldon, ASV, IHI, Partner, Imer, Clipper, MMD, Koshin, Rice, Gorman Rupp, CH&E, Cat Pumps, Comet, General Pump, Giant, AMida, Coleman, NAC, Gradall, Square Shooter, Kent, Stanley, Tamco, Toku, Hatz, Kohler, Robin, Wisconsin, Northrock, Oztec, Toker TK, Rol-Air, Small Line, Wanco, Yanmar

Important

Read, understand and obey these safety rules and operating instructions before operating this machine. Only trained and authorized personnel shall be permitted to operate this machine. This manual should be considered a permanent part of your machine and should remain with the machine at all times. If you have any questions, contact us.



www.discount-equipment.com

Contents

Introduction	1
Symbol and Hazard Pictorials Definitions	4
General Safety	6
Work Area Safety	10
Legend	15
Controls	16
Inspections	22
Operating Instructions	34
Transport and Lifting Instructions	39
Maintenance	41
Specifications	44
Reporting Safety Defects	45

Copyright © 2011 Terex Corporation

First Edition: Third Printing, December 2014

"Terex" is a registered trademark of Terex USA, LLC in the USA and many other countries.

Introduction

About this manual

Terex appreciates your choice of our machine for your application. Our number one priority is user safety, which is best achieved by our joint efforts. This book is an operation and daily maintenance manual for the user or operator of a Terex machine.

This manual should be considered a permanent part of your machine and should remain with the machine at all times. If you have any questions, contact Terex.

Product Identification

The machine serial number is located on the serial label.

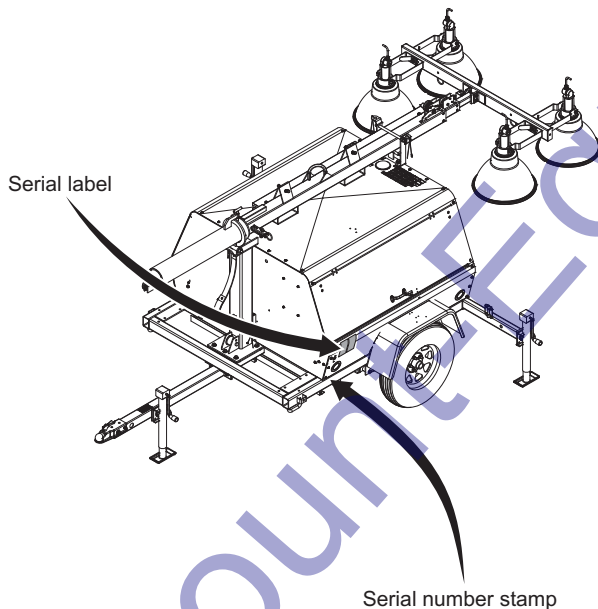

Intended Use

This machine is intended to be used only to provide lighting and electrical power to a work site. Use of this product in any other way is prohibited and contrary to its intended use.

Bulletin Distribution and Compliance

Safety of product users is of paramount importance to Terex. Various bulletins are used by Terex to communicate important safety and product information to dealers and machine owners.

The information contained in the bulletins is tied to specific machines using the machine model and serial number.

Distribution of bulletins is based on the most current owner on record along with their associated dealer, so it is important to register your machine and keep your contact information up to date.

To ensure safety of personnel and the reliable continued operation of your machine, be sure to comply with the action indicated in a respective bulletin.

Introduction

Contacting the Manufacturer

At times it may be necessary to contact Terex. When you do, be ready to supply the model number and serial number of your machine, along with your name and contact information. At minimum, Terex should be contacted for:

Accident reporting

Questions regarding product applications and safety

Standards and regulatory compliance information

Current owner updates, such as changes in machine ownership or changes in your contact information. See Transfer of Ownership, below.

Transfer of Machine Ownership

Taking a few minutes to update owner information will ensure that you receive important safety, maintenance and operating information that applies to your machine.

Please register your machine by visiting us on the web at www.genielift.com or by calling us toll free at 1-800-536-1800.



Danger

Failure to obey the instructions and safety rules in this manual will result in death or serious injury.

Do Not Operate Unless:

- You learn and practice the principles of safe machine operation contained in this operator's manual.

1 Avoid hazardous situations.

Know and understand the safety rules before going on to the next section.

- 2 Always perform a pre-operation inspection.
 - 3 Always perform function tests prior to use.
 - 4 Inspect the workplace.
 - 5 Only use the machine as it was intended.
- You read, understand and obey the manufacturer's instructions and safety rules—safety and operator's manuals and machine decals.
 - You read, understand and obey employer's safety rules and worksite regulations.
 - You read, understand and obey all applicable governmental regulations.
 - You are properly trained to safely operate the machine.

Introduction

Hazard Classification

Decals on this machine use symbols, color coding and signal words to identify the following:



Safety alert symbol—used to alert you to potential personal injury hazards. Obey all safety messages that follow this symbol to avoid possible injury or death.

DANGER

Indicates a hazardous situation that if not avoided, will result in death or serious injury.

WARNING

Indicates a hazardous situation that if not avoided, could result in death or serious injury.

CAUTION

Indicates a hazardous situation that if not avoided, could result in minor or moderate injury.















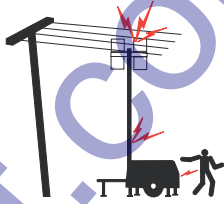
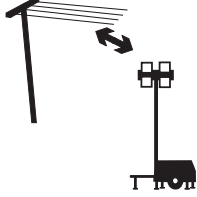
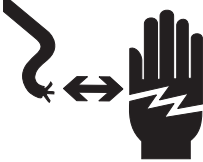



NOTICE

Indicates information considered important, but not hazard related (e.g. messages related to property damage)

















Safety Sign Maintenance

Replace any missing or damaged safety signs. Keep operator safety in mind at all times. Use mild soap and water to clean safety signs. Do not use solvent-based cleaners because they may damage the safety sign material.

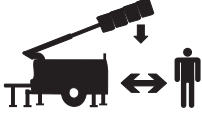
Symbol and Hazard Pictorials Definitions

				
Read the operator's manual	Electrocution hazard	Stop engine	Earth ground	Electrocution hazard
				
Maintain required clearance	Explosion / Burn hazard	Disconnect battery Read the service manual	Crush hazard	Keep away from moving parts
				
Keep away from moving parts	Stay clear of belts and fan	Burn hazard	Explosion / Burn hazard	Corrosive acid.
				
Explosion hazard	Do not use ether or other high energy starting aids on machines equipped with glow plugs.	No smoking	No flame	No flame

Symbol and Hazard Pictorials Definitions

				
Burn hazard	Burn hazard	Burn hazard	Stay clear of hot exhaust	Stay clear of hot exhaust
				
Burn hazard, hot components	Stay clear of hot surfaces under cover	Carbon Monoxide hazard	Wear protective clothing	Shattering glass hazard
				
Crushing hazard	Stay clear of descending mast	Tip-over hazard	Deploy outriggers before raising mast	Tip-over hazard, tow speed
				
Lifting point	Tie-down point			

General Safety

228712

WARNING

Crush Hazard
A falling mast may result in death or serious injury.

Before lowering mast:
Retract mast until upper retaining bar locks into mast and no red is visible on mast.

When mast is fully retracted, pull lower retaining bar and lower mast.

228712 A

228711

WARNING

Crush Hazard
Contact with moving parts can result in death or serious injury.

Keep away from moving parts.

228711 A

97675

WARNING

Burn Hazard
Hot fluid under pressure can scald.

Allow to cool before opening.

97675 B

133482

WARNING

Tip-over Hazard
Raising tower without correctly securing outriggers could result in machine tipping over, which could result in death or serious injury.

Do not raise tower unless outriggers are secured. Lower or extend outrigger jack and secure with pin.

133482 A

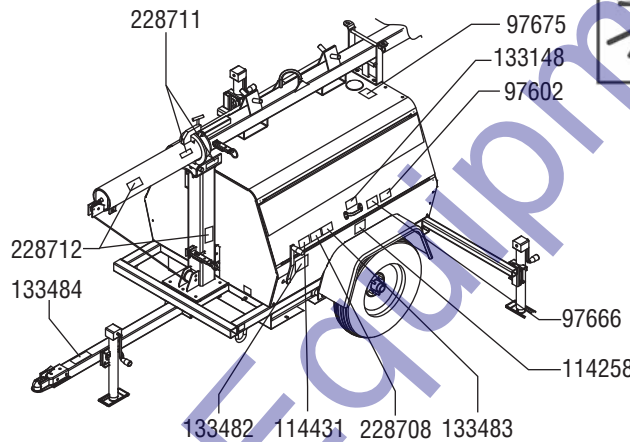

133148

DANGER

Electrocution hazard.
Contact with voltage will result in death or serious injury.

Shut down engine/generator and disconnect battery supply before servicing.

Read the service manual.

133148 D

97666

WARNING

Improper operation or maintenance can result in serious injury or death.

Read and understand operator's manual and all safety signs before using or maintaining machine. If you do not understand the information in the manuals, consult your supervisor, the owner or the manufacturer.

97666 B

228708

DANGER

Carbon Monoxide Hazard
Using a light tower indoors will result in death or serious injury in minutes. Light tower exhaust contains carbon monoxide, a poison you cannot see or smell.

Do not use a light tower indoors. Use only outside and far from open windows, doors and vents.

228708 A

133484

WARNING

Tip-over Hazard
Exceeding restricted towing speeds may cause machine tip-overs or collisions, which could result in death or serious injury.

Slow down for curves, adverse weather, hazardous road conditions, road construction, towing vehicle limitations and expressway exits. Obey all local and national towing speed laws.

mph
km/h

133484 A

97602

WARNING

Explosion Hazard
Death or serious injury can result from the use of ether or other high energy starting aids.

Do not use ether or other high energy starting aids on machines equipped with glow plugs or grid heater.

97602 C

114431

DANGER

Electrocution Hazard
Death or injury can result from contacting electric power lines. Always contact the electric power line owner. The electric power shall be disconnected or the power lines moved or insulated before machine operations begin.

Maintain required clearance.

Line Voltage	Required Clearance
0 to 50kV	10 ft 3.0 m
50 to 200kV	15 ft 4.6 m
200 to 350kV	20 ft 6.1 m
350 to 500kV	25 ft 7.6 m
500 to 750kV	35 ft 10.6 m
750 to 1000kV	45 ft 13.7 m
over 1000kV	Refer to Operator's Manual

114431 B

133483

WARNING

Burn Hazard
Contact with hot surfaces under cover can cause burns.

Do not touch. Allow surfaces to cool before servicing.

133483 A

114258

DANGER

Burn Hazard
Fuel and fumes can explode and burn.

No smoking. No flame. Stop engine.

114258 A

General Safety

161699

1
3

⚠ **DANGER**

Electrocution hazard.
Contact with voltage will result in death or serious injury.

Shut down engine/generator and disconnect battery supply before servicing.

Read the service manual. 161699 A

2
4

T108022

⚠ **WARNING**

Burn Hazard
Contact with hot components could result in death or serious injury.

Keep away from hot components.

T108022 A

133483

⚠ **WARNING**

Burn Hazard
Contact with hot surfaces under cover can cause burns.

Do not touch.
Allow surfaces to cool before servicing.

133483 A

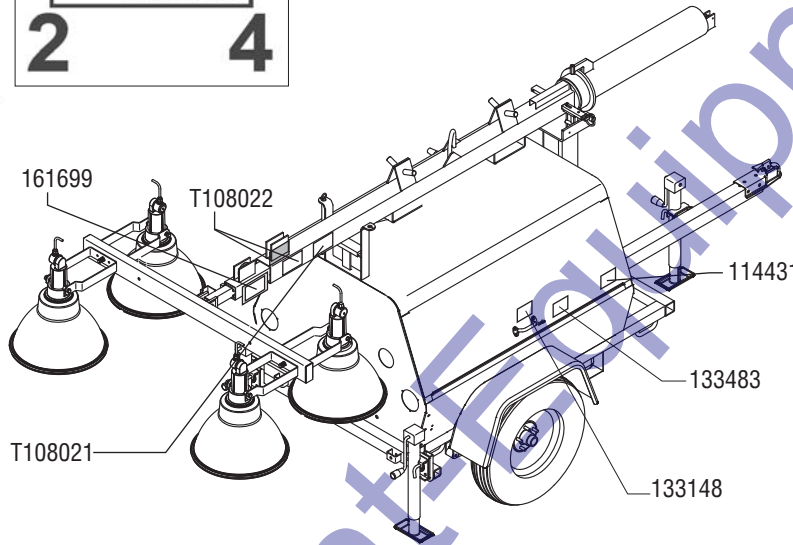

T108021

⚠ **WARNING**

Bodily Injury Hazard
Shattering glass could result in death or serious injury.

Keep protective barrier in place.

T108021 A

114431

⚠ **DANGER**

Electrocution Hazard
Death or injury can result from contacting electric power lines.

Always contact the electric power line owner. The electric power shall be disconnected or the power lines moved or insulated before machine operations begin.

114431 B

Maintain required clearance.	
Line Voltage	Required Clearance
0 to 50KV	10 ft 3.0 m
50 to 200KV	15 ft 4.6 m
200 to 350KV	20 ft 6.1 m
350 to 500KV	25 ft 7.6 m
500 to 750KV	36 ft 10.6 m
750 to 1000KV	45 ft 13.7 m
over 1000KV	Refer to Operator's Manual

133148

⚠ **DANGER**

Electrocution hazard.
Contact with voltage will result in death or serious injury.

Shut down engine/generator and disconnect battery supply before servicing.

Read the service manual. 133148 D

General Safety

229782



229781

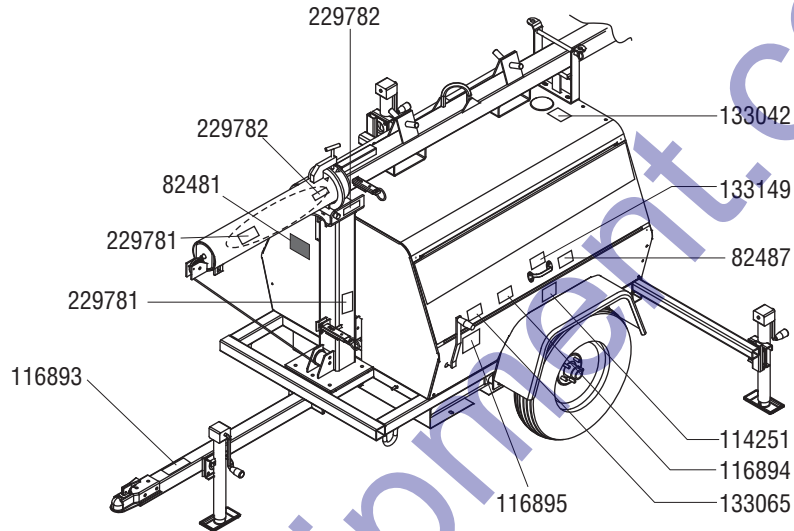
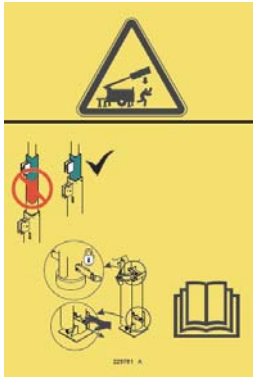

116893



82487



114251



133149



133042



116895



133065



82481



116894



General Safety

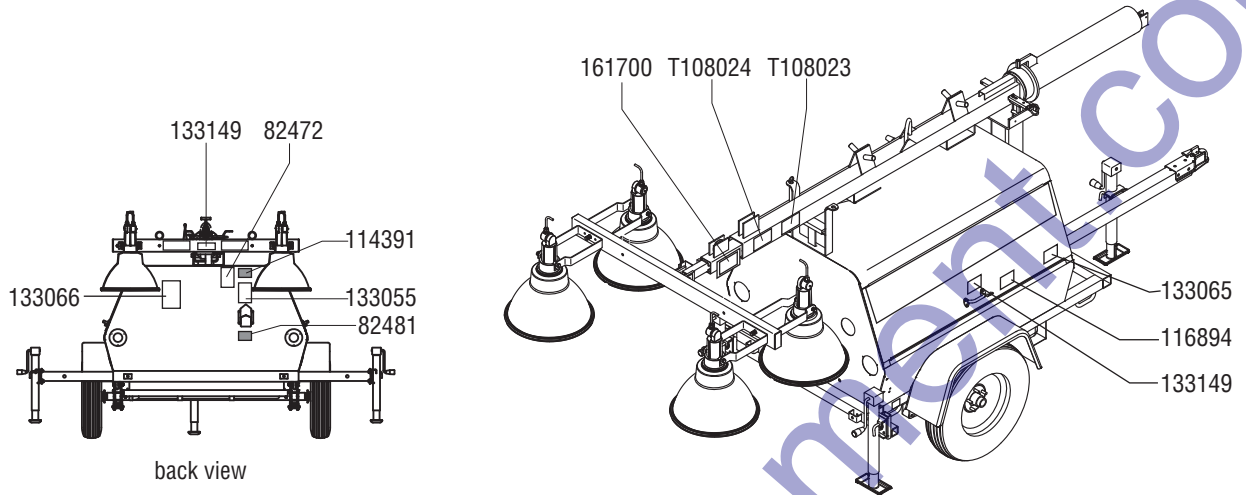

back view

82481



82472



161700



114391

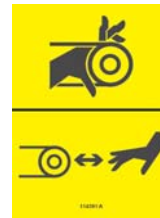

133066



T108023



133055



133149



133065

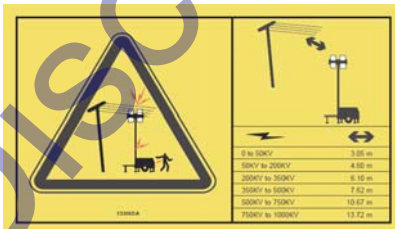

116894



T108024



Work Area Safety

▲ Electrocutation Hazards

This machine is not electrically insulated and will not provide protection from contact with or proximity to electrical current.

Obey all local and governmental regulations regarding required clearance from electrical power lines. At a minimum, the required clearance contained in the chart below must be followed.

Line Voltage	Required Clearance	
0 to 50KV	10 ft	3.05 m
>50 to 200KV	15 ft	4.60 m
>200 to 350KV	20 ft	6.10 m
>350 to 500KV	25 ft	7.62 m
>500 to 750KV	35 ft	10.67 m
>750 to 1000KV	45 ft	13.72 m
over 1000KV	see below	

For power lines over 1000kV, the minimum clearance distance must be established by the utility owner or operator or by a registered professional engineer who is a qualified person with respect to electrical power transmission and distribution.

Allow for mast movement, electrical line sway or sag, and beware of strong or gusty winds.

Do not operate the machine during lightning or storms.

Do not use the machine as a ground for welding.

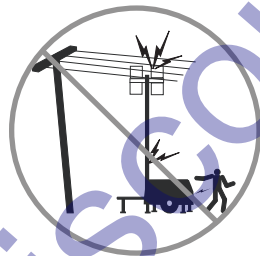

Keep away from the machine if it contacts energized power lines. Personnel must not touch or operate the machine until energized power lines are shut off.

Do not connect wires directly to the generator. Connect auxiliary equipment only to the power outlets provided.

Do not perform service or replace the lamps with the engine/generator running or batteries connected.

This machine should be grounded in accordance with all local electrical codes. Consult the local electrical codes or authority having jurisdiction in the area where the machine will be used for specific requirements.

There is a permanent conductor between the generator (static winding) and the frame.

▲ Explosion and Fire Hazards

Do not start the engine if you smell or detect liquid petroleum gas (LPG), gasoline, diesel fuel or other explosive substances.



Do not refuel the machine with the engine running.

Do not refuel the machine while it is hot. Allow to cool for several minutes before refueling.

Do not spill fuel inside the engine compartment.

Refuel the machine and charge the battery only in an open, well-ventilated area away from sparks, flames and lighted tobacco.

Do not operate the machine in hazardous locations or locations where potentially flammable or explosive gases or particles may be present.

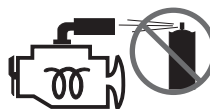

Do not spray ether into engines equipped with glow plugs.

Work Area Safety

⚠ Tip-over Hazards



Do not raise the mast unless all outriggers are properly deployed, the foot pads are in firm contact with the ground and the machine is level.

Do not set the machine up on a surface where it cannot be leveled using only the leveling jacks.

Do not rotate mast while standing on the platform.

Do not hang objects from the lights or the mast.

Do not use the mast to raise material or personnel.

Do not move the machine unless the mast is lowered to the horizontal position.



Do not raise the mast when wind speeds may exceed 62 mph / 100 km/h. Do not alter or disable machine components that in any way affect safety and stability.

Do not alter or disable machine components that in any way affect safety and stability.

Do not adjust or stow the outriggers when the mast is raised.

Be sure the tires are in good condition and the lug nuts tightened.



Do not place ladders or scaffolds against any part of the machine.

Do not use the machine on a moving or mobile surface or vehicle.

⚠ Crushing Hazard



Do not lower the mast unless the area below is clear of personnel and obstructions.

Keep hands and fingers away from any potential pinch points.

Do not lower the mast until the mast is retracted and the upper retaining bar is locked into the mast. No red should be visible on the mast.

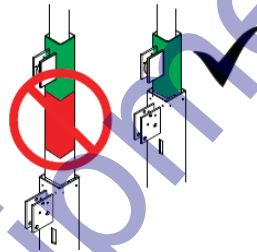

Collision Hazards

Check the work area for overhead obstructions or other possible hazards.

⚠ Burn Hazards



Do not touch the lamp fixtures while they are turned on. Turn the lamps off and allow them to cool before touching.

Do not touch hot parts of the engine or tailpipe. Use protective gloves when handling hot parts.

Work Area Safety

▲ Bodily Injury Hazard

Do not use the machine indoors unless properly ventilated.

Do not breathe exhaust fumes.

Do not work on this equipment when mentally or physically fatigued.

Do not work on this equipment when under the influence of drugs or alcohol.

Stay clear of belts and fan when engine is running.

Do not use the machine if the protective barrier on any of the lamps is broken or punctured. Metal halide lamps produce shortwave ultra-violet radiation and can cause serious skin burns or eye inflammation if the protective barrier is not in place.

Do not use where people will remain close to the lamps for more than a few minutes unless adequate shielding or other safety precautions are used.

Stay clear of moving mast.

Do not grasp the cable.

Use proper lifting techniques when lifting and positioning the tongue of the machine.

Always replace the protective lamp cover after replacing the lamp bulbs.

▲ Fall Hazards

Do not climb or stand on any part of the light tower during maintenance or operation.

▲ Traffic Hazards

Stand clear of traffic when starting or checking the unit along the road.

▲ Damaged Machine Hazards

Do not use a damaged or malfunctioning machine.

Do not use a machine with a worn, frayed, kinked or damaged cable.

Conduct a thorough pre-operation inspection of the machine and test all functions before each work shift. Immediately tag and remove from service a damaged or malfunctioning machine.

Be sure all maintenance has been performed as specified in this manual and the appropriate Terex service manual.

Be sure the operator's manual is complete, legible and in the storage container located on the machine.

Be sure all decals are in place and legible.

Do not modify or alter the light tower without the prior written permission of the manufacturer.

Work Area Safety

▲ Component Damage Hazards

Do not turn the lights on unless the engine is running. Always turn the lights off before shutting down the engine.

Do not tow the light tower while the lamps are hot. Hot lamps will break if moved.

Do not replace lamp bulbs with any bulbs other than those specified on the machine and in this manual.

Note: Lamp bulbs contain mercury (Hg). Dispose of lamp bulbs according to local, state and federal laws.

Do not extend the mast when both red lines are visible on mast.

Do not retract a raised mast while the mast retaining pin is engaged.

Be sure lamp fixture connections are properly tightened before turning lights on.

▲ Battery Safety

Burn Hazards



Batteries contain acid. Always wear protective clothing and eye wear when working with batteries.

Avoid spilling or contacting battery acid. Neutralize battery acid spills with baking soda and water.

Do not use any battery charger greater than 12V to charge the battery.

Do not remove the vent caps from the battery when charging.

Do not expose the batteries or the charger to water or rain during charging.

Explosion Hazards



Keep sparks, flames and lighted tobacco away from batteries. Batteries emit explosive gas.



Do not contact the battery terminals or the cable clamps with tools that may cause sparks.

Work Area Safety

Electrocution/Burn Hazards

Avoid contact with electrical terminals.

Inspect the power cord for damage prior to each use.

Replace any damaged cord before operating.

Do not allow the power cord to become caught or crushed while raising, lowering or rotating the mast.

Avoid electrical shock from contact with battery terminals. Remove all rings, watches and other jewelry.

Lifting Hazard

Use the appropriate number of people and proper lifting techniques when lifting batteries.

▲ Towing Hazards

Read, understand and obey all of your tow vehicle manufacturer's recommendations, warnings and instructions before towing this machine.

Do not tow the machine unless the mast is retracted and lowered to the horizontal position and the travel lock pin is secured.

Do not tow the machine unless all outriggers have been retracted and stowed.

Do not overload your tow vehicle. Check the manufacturer's Gross Vehicle Weight Rating (GVWR). To obtain the gross vehicle weight, add the tongue weight of the trailer to the vehicle weight (including vehicle, passengers and cargo).

Do not load cargo on the machine. The light tower is not designed to carry any extra cargo.

Be sure the hitch is securely attached to the tow vehicle.

Be sure the safety chains (if required) are securely attached to the tow vehicle. Safety chains should be crossed below hitch.

Be sure that all driving lights are operational.

Be sure all hitch components, lights and mirrors and methods of attaching the trailer to the tow vehicle conform to local, state and federal regulations.

Do not tow the machine on public roads unless it meets all governmental regulations for towing.

Do not exceed 60 mph / 97 km/h. Obey all local and national towing speed laws.

Be sure to chock the wheels when parking on a hill.

Use extreme care and slow speeds while towing across uneven terrain, debris, holes or drop-offs.

Note: Do not tow machine when engine is running! This can cause severe engine/radiator damage and WILL NOT BE COVERED UNDER WARRANTY!

Lockout After Each Use

When leaving the machine unattended, secure from unauthorized use. Unauthorized personnel may attempt to operate the machine without proper instruction, creating an unsafe condition.

Legend

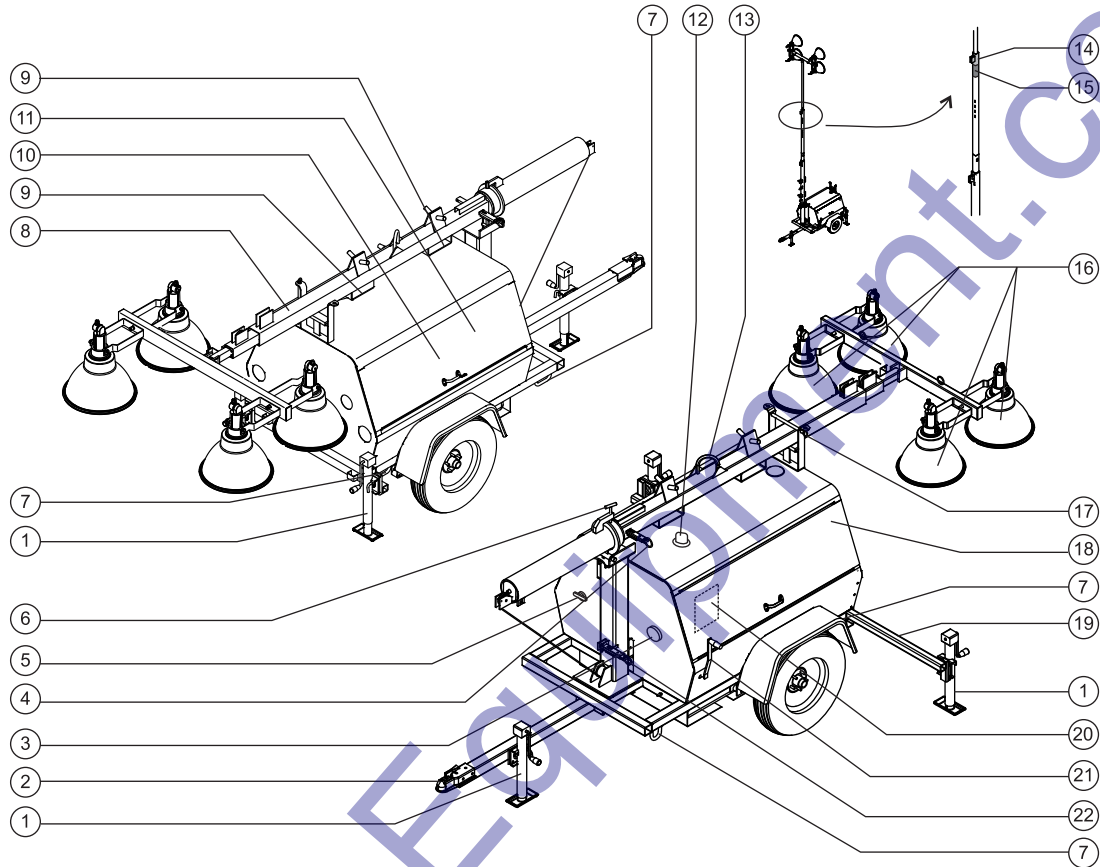

- | | |
|---|---|
| <ul style="list-style-type: none"> 1 Leveling jack 2 Tongue with trailer hitch 3 Air shutoff system Emergency Stop button (if equipped with automatic air shutoff system) 4 Upper retaining bar 5 Air shutoff system pull handle (if equipped with manual air shutoff system) 6 T-handle for mast rotation lock 7 Tie-downs 8 Mast 9 Forklift pockets 10 Curbside door 11 Ballast (located inside cabinet) | <ul style="list-style-type: none"> 12 Flashing beacon (if equipped with auto-start system) 13 Lifting eye 14 Green stripe 15 Red stripe 16 Lamps 17 Travel lock pin 18 Roadside door 19 Outrigger 20 Control panel (located inside cabinet) 21 Raise/lower winch (for models with manual winch) 22 Lower retaining bar |
|---|---|

Controls

AL4

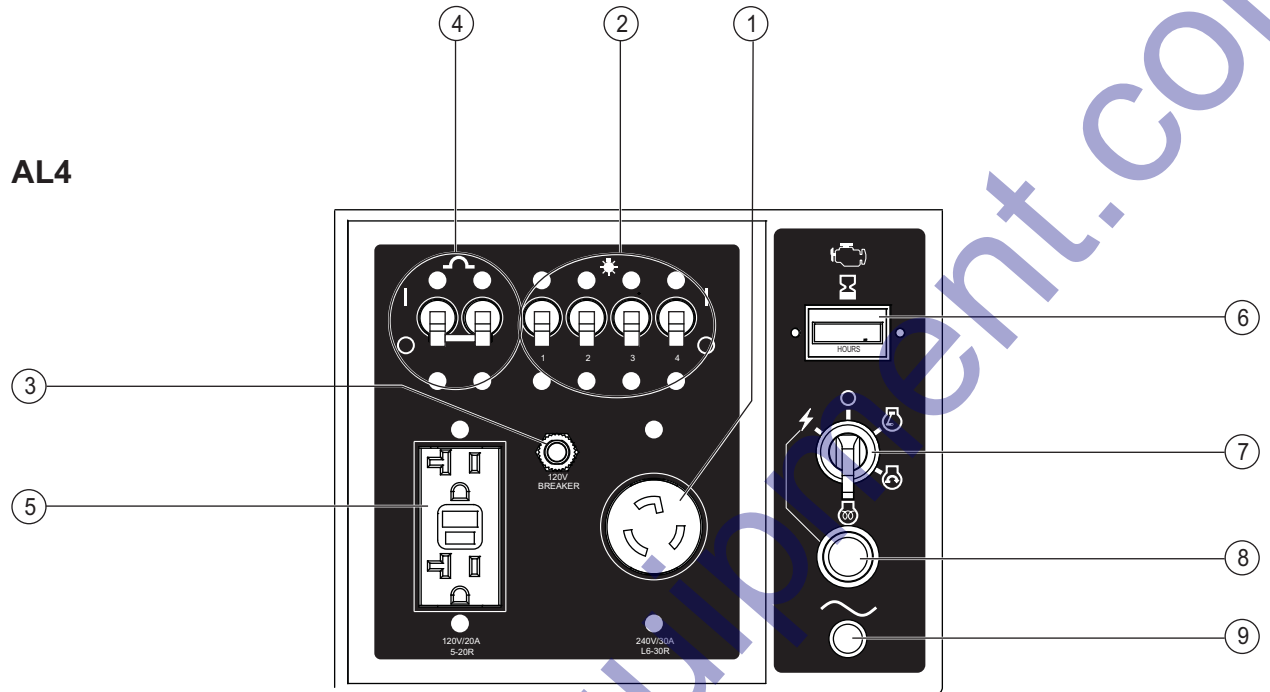

AL5 8kW

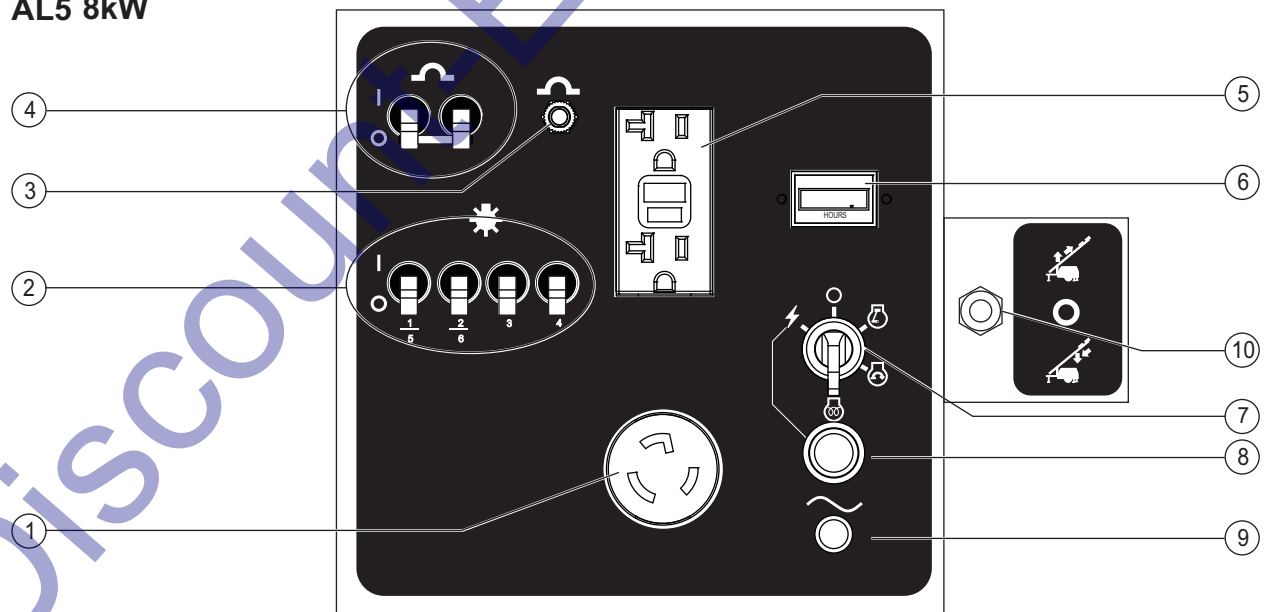

Controls

Control Panel

- 1 T-lock receptacle, 240V/30A

- 2 Light switches

Move each light switch up to turn on the indicated light. Move each light switch down to turn off the indicated light. On models with 6 lights, the switches marked 1/5 and 2/6 turn on 2 lights each. On models with 4 lights, each switch turns on one light.

- 3 Circuit breaker for GFI receptacle

- 4 Main circuit breaker

Move the main circuit breaker switch up on the control panel before turning the individual light switches on or before attempting to use the convenience receptacles.

- 5 Duplex receptacle with GFI, 120V/20A

Convenience duplex receptacle with Ground Fault Interrupter (GFI).

- 6 Hour meter

The hour meter displays the number of hours the machine has operated.

- 7 Ignition switch for engine

Turn the ignition switch to the prime position and hold the engine prime button down to prime the engine.

Hold the prime button down and turn the ignition switch to the start position to start the engine.

Turn the ignition switch to the off position to turn the engine off.

- 8 Engine prime button

With the ignition switch in the run position, press and hold the prime button for 15 seconds before starting the engine. Release the prime button when the engine starts.

- 9 Alternator failure light

Light on indicates that the engine's DC alternator isn't producing enough voltage.

- 10 Raise/lower switch (if equipped with electric winch)

Move the switch up to raise and extend the mast. Move the switch down to retract and lower the mast.

Controls

AL5 12kW & 20kW

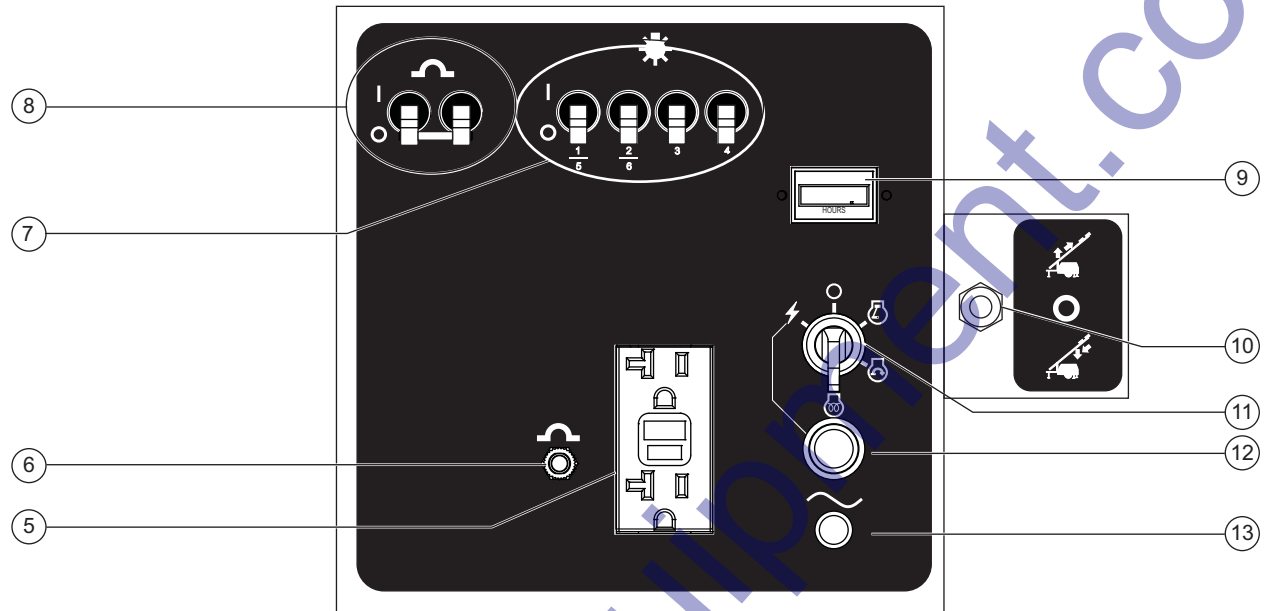

AL5 external panel

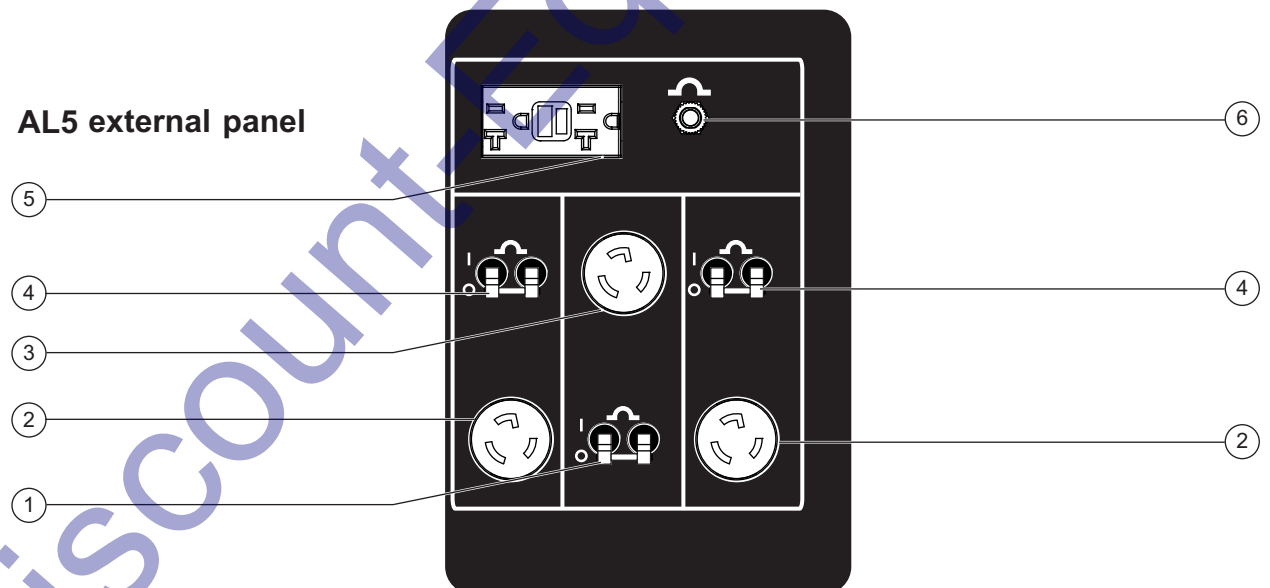

Controls

Control Panel

- | | |
|---|---|
| <p>1 Circuit breaker for twist-lock receptacle, 20 kW external panel only</p> <p>2 T-lock receptacle, 240V/30A</p> <p>3 T-lock receptacle, 20 kW external panel only</p> <p>4 Circuit breaker for twist-lock receptacle</p> <p>5 Duplex receptacle with ground Fault Interrupter GFI</p> <p>6 Circuit breaker for duplex receptacle</p> <p>7 Light switches</p> <p>Move each light switch up to turn on the indicated light. Move each light switch down to turn off the indicated light. On models with 6 lights, the switches marked 1/5 and 2/6 turn on 2 lights each. On models with 4 lights, each switch turns on one light.</p> <p>8 Main circuit breaker</p> <p>Move the main circuit breaker switch up on the control panel before turning the individual light switches on or before attempting to use the convenience receptacles.</p> <p>9 Hour meter</p> | <p>The hour meter displays the number of hours the machine has operated.</p> <p>10 Raise/lower switch (if equipped with electric winch)</p> <p>Move the switch up to raise and extend the mast. Move the switch down to retract and lower the mast.</p> <p>11 Ignition switch for engine</p> <p>Turn the ignition switch to the prime position and hold the engine prime button down to prime the engine.</p> <p>Hold the prime button down and turn the ignition switch to the start position to start the engine.</p> <p>Turn the ignition switch to the off position to turn the engine off.</p> <p>12 Engine prime button</p> <p>With the ignition switch in the run position, press and hold the prime button for 15 seconds before starting the engine. Release the prime button when the engine starts.</p> <p>13 Alternator failure light</p> <p>Light on indicates that the engine's DC alternator isn't producing enough voltage.</p> |
|---|---|

Controls

AL5 20kW tier 4 option

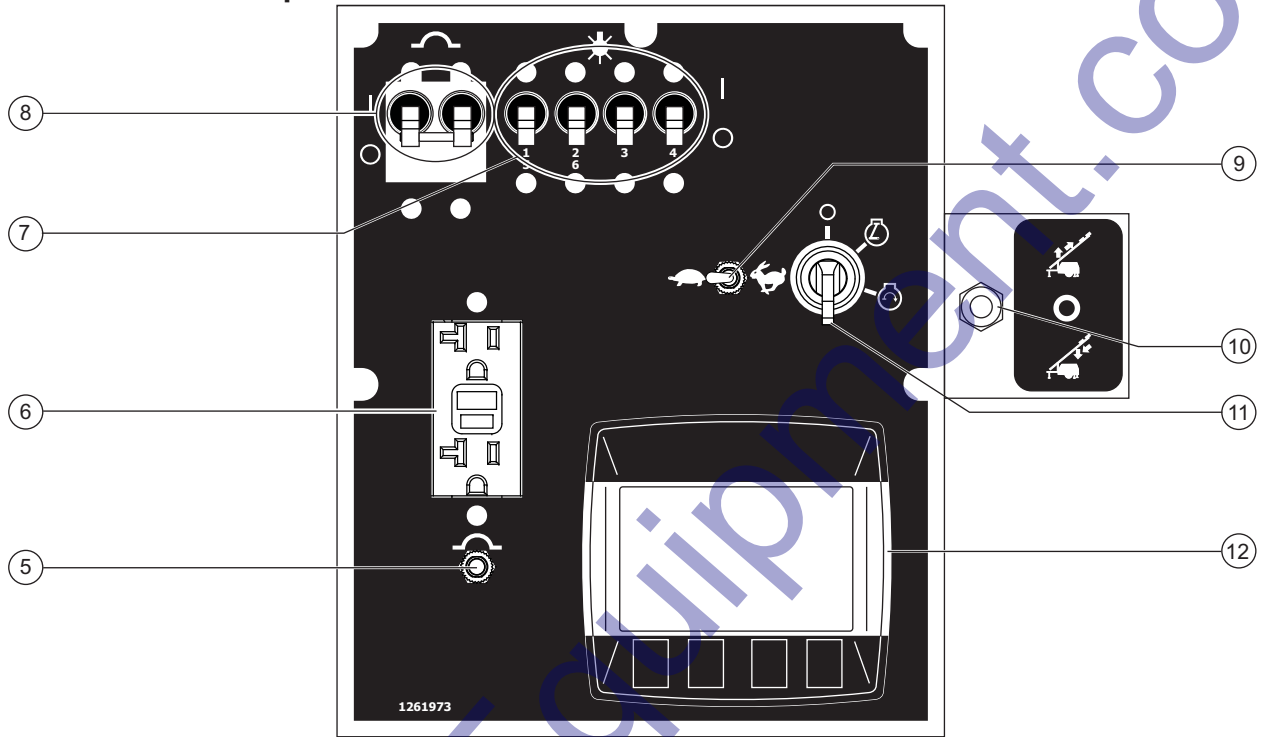

AL5 external panel

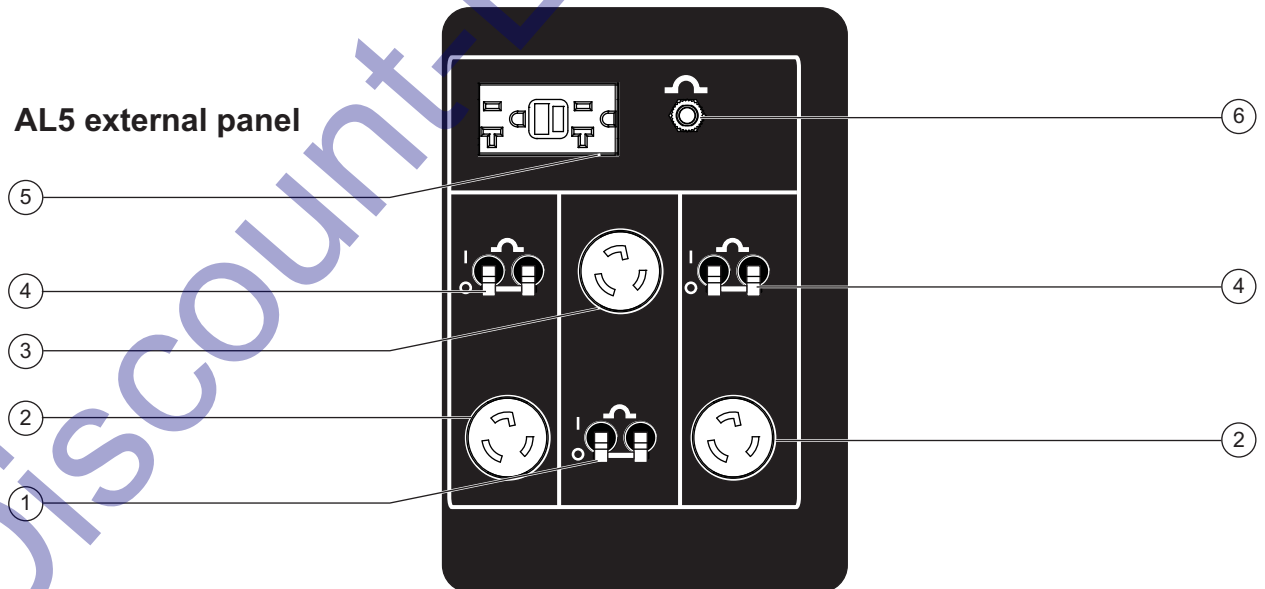

Controls

Control Panel

- 1 Circuit breaker for twist-lock receptacle, 20 kW external panel only
- 2 T-lock receptacle, 240V/30A
- 3 T-lock receptacle, 20 kW external panel only
- 4 Circuit breaker for twist-lock receptacle
- 5 Circuit breaker for duplex receptacle
- 6 Duplex receptacle with ground Fault Interrupter GFI
- 7 Light switches

Move each light switch up to turn on the indicated light. Move each light switch down to turn off the indicated light. On models with 6 lights, the switches marked 1/5 and 2/6 turn on 2 lights each. On models with 4 lights, each switch turns on one light.
- 8 Main circuit breaker

Move the main circuit breaker switch up on the control panel before turning the individual light switches on or before attempting to use the convenience receptacles.
- 9 Hi/Lo speed switch

The Hi/Lo speed control switch controls the engine speed.
- 10 Raise/lower switch (if equipped with electric winch)

Move the switch up to raise and extend the mast. Move the switch down to retract and lower the mast.
- 11 Ignition switch for engine

Turn the ignition switch to the prime position and hold the engine prime button down to prime the engine.

Hold the prime button down and turn the ignition switch to the start position to start the engine.

Turn the ignition switch to the off position to turn the engine off.
- 12 Digital read out

Displays vital engine operating information.

Inspections



Do Not Operate Unless:

- You learn and practice the principles of safe machine operation contained in this operator's manual.
 - 1 Avoid hazardous situations.
 - 2 **Always perform a pre-operation inspection.**

Know and understand the pre-operation inspection before going on to the next section.

- 3 Always perform function tests prior to use.
- 4 Inspect the workplace.
- 5 Only use the machine as it was intended.

Pre-operation Inspection Fundamentals

It is the responsibility of the operator to perform a pre-operation inspection and routine maintenance.

The pre-operation inspection is a visual inspection performed by the operator prior to each work shift. The inspection is designed to discover if anything is apparently wrong with a machine before the operator performs the function tests.

The pre-operation inspection also serves to determine if routine maintenance procedures are required. Only routine maintenance items specified in this manual may be performed by the operator.

Refer to the list on the next page and check each of the items.

If damage or any unauthorized variation from factory delivered condition is discovered, the machine must be tagged and removed from service.

Repairs to the machine may only be made by a qualified service technician, according to the manufacturer's specifications. After repairs are completed, the operator must perform a pre-operation inspection again before going on to the function tests.

Scheduled maintenance inspections shall be performed by qualified service technicians, according to the manufacturer's specifications and the requirements listed in the responsibilities manual.

Inspections

Pre-operation Inspection

- Be sure that the operator's manual is complete, legible and in the storage container located on the machine.
- Be sure that all decals are legible and in place. See Inspections section.
- Check for engine oil leaks and proper fluid level. Add oil if needed. See Maintenance section.
- Check for engine coolant leaks and proper coolant level. Add coolant if necessary. See Maintenance section.
- Check for battery fluid leaks and proper fluid level. Add distilled water if needed. See Maintenance section.
- Check for proper tire pressure and lug nut torque. Add air to tires if needed. See Maintenance section.

Check the following components or areas for damage, improperly installed or missing parts and unauthorized modifications:

- Electrical components, wiring and electrical cables
- Mast components
- Mast locking pins
- Latches and pins
- Tires and wheels
- Trailer lights and reflectors
- Outriggers, leveling jacks and foot pads
- Winch

- Nuts, bolts and other fasteners
- Lamp fixtures, connections and bulbs
- Cable (kinks, frays and abrasions)
- Safety chains
- Engine and related components
- Fuel tanks
- Generator
- Grounding rod and lug

Check entire machine for:

- Cracks in welds or structural components
- Dents or damage to machine
- Excessive rust, corrosion or oxidation
- Be sure that all structural and other critical components are present and all associated fasteners and pins are in place and properly tightened.
- Be sure the that the battery is in place and properly connected.
- After you complete your inspection, be sure that all compartment covers are in place and latched.

Inspections



Do Not Operate Unless:

- You learn and practice the principles of safe machine operation contained in this operator's manual.
 - 1 Avoid hazardous situations.
 - 2 Always perform a pre-operation inspection.
 - 3 Always perform function tests prior to use.**

Know and understand the function tests before going on to the next section.

- 4 Inspect the workplace.
- 5 Only use the machine as it was intended.

Function Test Fundamentals

The function tests are designed to discover any malfunctions before the machine is put into service. The operator must follow the step-by-step instructions to test all machine functions.

A malfunctioning machine must never be used. If malfunctions are discovered, the machine must be tagged and removed from service. Repairs to the machine may only be made by a qualified service technician, according to the manufacturer's specifications.

After repairs are completed, the operator must perform a pre-operation inspection and function tests again before putting the machine into service.

Inspections

Function Tests

Setup

- 1 Position the light tower at the desired work site.
- 2 Chock the wheels.
- 3 Disconnect the trailer lights and the safety chains.
- 4 Open the latch on the trailer hitch.
- 5 Pull the release pin on the tongue jack and rotate into vertical position.
- 6 Turn the leveling jack handle to lower the front outrigger foot pad and raise the tongue of the machine enough to clear the tow vehicle.

Release the spring pin on the side outriggers and slide them out into the deployed position. Make sure the outriggers are locked in place. Rotate the leveling jack into vertical position.

- 7 Turn the leveling jack handles to level the machine. Level the machine using only the leveling jacks

Note: the outriggers are not designed to lift the tires of the unit off the ground.

- 8 Check the bubble level (if equipped) on the front of the machine to make sure the machine is level.

- 9 Ground the light tower according to your local electrical code. A grounding rod is supplied inside the cabinet and a grounding lug is provided on the front of the machine, near the bottom.



Note: This machine should be grounded in accordance with all local electrical codes. Consult the local electrical codes or authority having jurisdiction in the area where the machine will be used for specific requirements.

Test Machine Functions (models with manual winch)

By raising and extending, then retracting and lowering the mast back to the horizontal position, the following functions will be tested: **winches, latches, mast extension and mast rotation.**

- 10 Remove the retaining pin and travel lock from the top of the mast.
- 11 Turn the raise/lower winch handle clockwise until the mast raises approximately 2 feet / 60 cm.
 - ⊙ Result: A clicking sound should be heard as the mast raises.
- 12 Release the winch handle.
 - ⊙ Result: The winch brake should hold the mast.

Inspections

- 13 Continue to raise the mast until the lower retaining bar locks into the mast.
 - ⊙ Result: The mast sections should raise smoothly, free of hesitation or binding.
- 14 Insert the retaining pin through the lower retaining bar.
- 15 Remove the retaining pin and pull the upper retaining pin out.
- 16 Turn the extend/retract winch handle clockwise until the mast extends approximately 2 feet / 60 cm.
 - ⊙ Result: A clicking sound should be heard as the mast extends.
- 17 Release the winch handle.
 - ⊙ Result: The winch brake should hold the mast.
- 18 Continue to extend the mast until the mast reaches full vertical position. Stop extending the mast when the red line is visible on the mast.
 - ⊙ Result: The mast should extend smoothly, free of hesitation or binding.
- 19 Turn the T-handle to release the mast rotation lock.
- 20 Rotate the mast clockwise and then counterclockwise as far as it will go in either direction.
 - ⊙ Result: The mast should rotate smoothly and easily in both directions.
- 21 Rotate the mast to line up the arrows on the front of the mast.
- 22 Tighten the T-handle to secure the mast.
- 23 Attempt to rotate the mast in both directions.
 - ⊙ Result: The mast should not rotate.
- 24 Turn the winch handle counterclockwise until the upper retaining bar locks into the mast and no red line is visible on the mast.
 - ⊙ Result: No clicking sound should be heard when the winch handle is turned.
- 25 When the mast sections are fully retracted, pull the lower retaining bar.
- 26 Begin lowering the mast to the horizontal position by turning the raise/lower winch handle counterclockwise.
 - ⊙ Result: No clicking sound should be heard when the winch handle is turned.
- 27 Turn the winch handle counterclockwise until the mast is lowered into the travel lock.
- 28 Insert the travel lock pin and the retaining pin.

Inspections

Test Machine Functions (models with electric winch)

- 29 Remove the retaining pin and travel lock from the top of the mast.
- 30 Move the raise/lower switch up until the mast raises approximately 2 feet / 60 cm.
 - ⊙ Result: The mast sections should raise smoothly, free of hesitation or binding.
- 31 Release the raise/lower switch.
 - ⊙ Result: The winch brake should hold the mast.
- 32 Continue to raise the mast until the lower retaining bar locks into the mast.
 - ⊙ Result: The mast should raise smoothly, free of hesitation or binding.
- 33 Insert the retaining pin through the lower retaining bar.
- 34 Remove the retaining pin and pull the upper retaining pin out.
- 35 Move the raise/lower switch up until the mast extends approximately 2 feet / 60 cm.
 - ⊙ Result: The mast should extend smoothly, free of hesitation or binding.
- 36 Release the raise/lower switch.
- 37 Result: The winch brake should hold the mast.
- 38 Continue to extend the mast until the mast reaches full vertical position. Stop extending the mast when the red line is visible on the mast.
 - ⊙ Result: The mast should extend smoothly, free of hesitation or binding.
- 39 Turn the T-handle to release the mast rotation lock.
- 40 Rotate the mast clockwise and then counterclockwise as far as it will go in either direction.
 - ⊙ Result: The mast should rotate smoothly and easily in both directions.
- 41 Rotate the mast to line up the arrows on the front of the mast.
- 42 Tighten the T-handle to secure the mast.
- 43 Attempt to rotate the mast in both directions.
 - ⊙ Result: The mast should not rotate.
- 44 Move the raise/lower switch down until the upper retaining bar locks into the mast and no red line is visible on the mast.
 - ⊙ Result: The mast should retract smoothly, free of hesitation or binding.
- 45 When the mast sections are fully retracted, pull the lower retaining bar.

Inspections

- 46 Begin lowering the mast to the horizontal position by moving the raise/lower switch down.
- 47 Result: The mast sections should lower smoothly, free of hesitation or binding.
- 48 Lower the mast until the mast is resting in the travel lock.
- 49 Insert the travel lock pin and the retaining pin.

Test the Lights

- 50 Make sure the circuit breakers and the light switches are in the off position.

Note: Be sure the lamp fixture connections are properly tightened before turning the lights on.

- 51 Start the engine. See Starting the Engine in the Operating Instructions section.
- 52 Turn the main circuit breakers to the on position.
- 53 Turn the light switches to the on position.

Note: For machines equipped with 20kW tier 4 option flip the Hi/Lo speed switch to the Hi position before turning the light switches on.

- ☉ Result: The lights should come on.

Note: It can take up to 20 minutes for the lights to reach full intensity. If the lights are turned off and turned back on while they are still warm, they will not light up again for 20-30 minutes.

Note: Make sure the circuit breaker and the light switches are turned off before shutting down the engine.



Do Not Operate Unless:

- You learn and practice the principles of safe machine operation contained in this operator's manual.
 - 1 Avoid hazardous situations.
 - 2 Always perform a pre-operation inspection.
 - 3 Always perform function tests prior to use.
 - 4 Inspect the workplace.**

Know and understand the workplace inspection before going on to the next section.
 - 5 Only use the machine as it was intended.

Workplace Inspection Fundamentals

The workplace inspection helps the operator determine if the workplace is suitable for safe machine operation. It should be performed by the operator prior to moving the machine to the workplace.

It is the operator's responsibility to read and remember the workplace hazards, then watch for and avoid them while moving, setting up and operating the machine.

Inspections

Workplace Inspection Checklist

Be aware of and avoid the following hazardous situations:

- drop-offs or holes
- bumps, floor obstructions or debris
- sloped surfaces
- unstable or slippery surfaces
- overhead obstructions and high voltage conductors
- hazardous locations
- inadequate surface support to withstand all load forces imposed by the machine
- wind and weather conditions
- the presence of unauthorized personnel
- other possible unsafe conditions

Inspections

Inspection for Decals with Words

Determine whether the decals on your machine have words or symbols. Use the appropriate inspection to verify that all decals are legible and in place.

Below is a numerical list with quantities and descriptions.

Part No.	Decal Description	Qty
28159	Label – Diesel	1
28161	Warning – Crushing Hazard	1
28162	Warning – Bodily Injury Hazard	2
31788	Danger – Explosion/Burn Hazard	1
52475	Label – Transport Tie-down	4
72086	Label – Lifting Point	2
97518	Instruction – Lamp Disposal	1
97602	Warning – Explosion Hazard	1
97666	Warning – Improper Operation	1
97675	Warning – Burn Hazard, Hot Components	1
114258	Danger – Explosion Hazard	1
114431	Danger – Electrocution hazard	2
114464	Label – Travel lock	1
116901	Label – AC Control Panel, AL4	1
116902	Label – Engine Control Panel, AL4	1
133012	Danger – Burn/Carbon Monoxide Hazard	1
133017	Warning – Crushing Hazard	1
133062	Label – Ground	1
133063	Label – Transport Diagram	1
133148	Danger – Electrocution hazard	2
133462	Instruction – Perkins Engine Specifications	1
133463	Instruction – Kubota Engine Specifications	1
133482	Warning – Tip-over Hazard, Outriggers	1
133483	Warning – Burn Hazard	2
133484	Warning – Tow Speed	1

Part No.	Decal Description	Qty
161699	Danger – Electrocution Hazard	1
227348	Instructions – Tire Specifications	1
227349	Instructions – Kubota V1505 Engine Specifications	1
227350	Instructions – Isuzu Engine Specifications	1
227518	Cosmetic – Terex Logo, AL4	2
227519	Cosmetic – Terex Logo, AL5	2
228708	Danger – CO Hazard	1
228709	Label – Neutral Bond	1
228710	Instructions – Operating Instructions	1
228711	Warning – Crush Hazard	1
228712	Warning – Crush Hazard, Mast	1
228713	Label – Electric Winch Switch	1
228714	Label – Manual Winch	1
229102	Label – Arrow	2
235730	Cosmetic – AL4	2
235731	Cosmetic – AL5	2
237271	Label – AL5 Control Panel, 8 kW	1
237272	Label – AL Control Panel, 12 & 20 kW	1
237273	Label – AL Control Panel, 20 kW, External Power	1
237274	Label – AL Control Panel, 12 kW, External Power	1
841890	Conspicuity Tape	2
851691	Label – #1	1
851692	Label – #2	1
851693	Label – #3	1
851694	Label – #4	1
1261973	Label – AL Control Panel, 20 kW Tier 4	1
T108021	Warning – Bodily Injury Hazard	1
T108022	Warning – Burn hazard	2

■ Shading indicates decal is hidden from view, i.e. under covers

Inspections

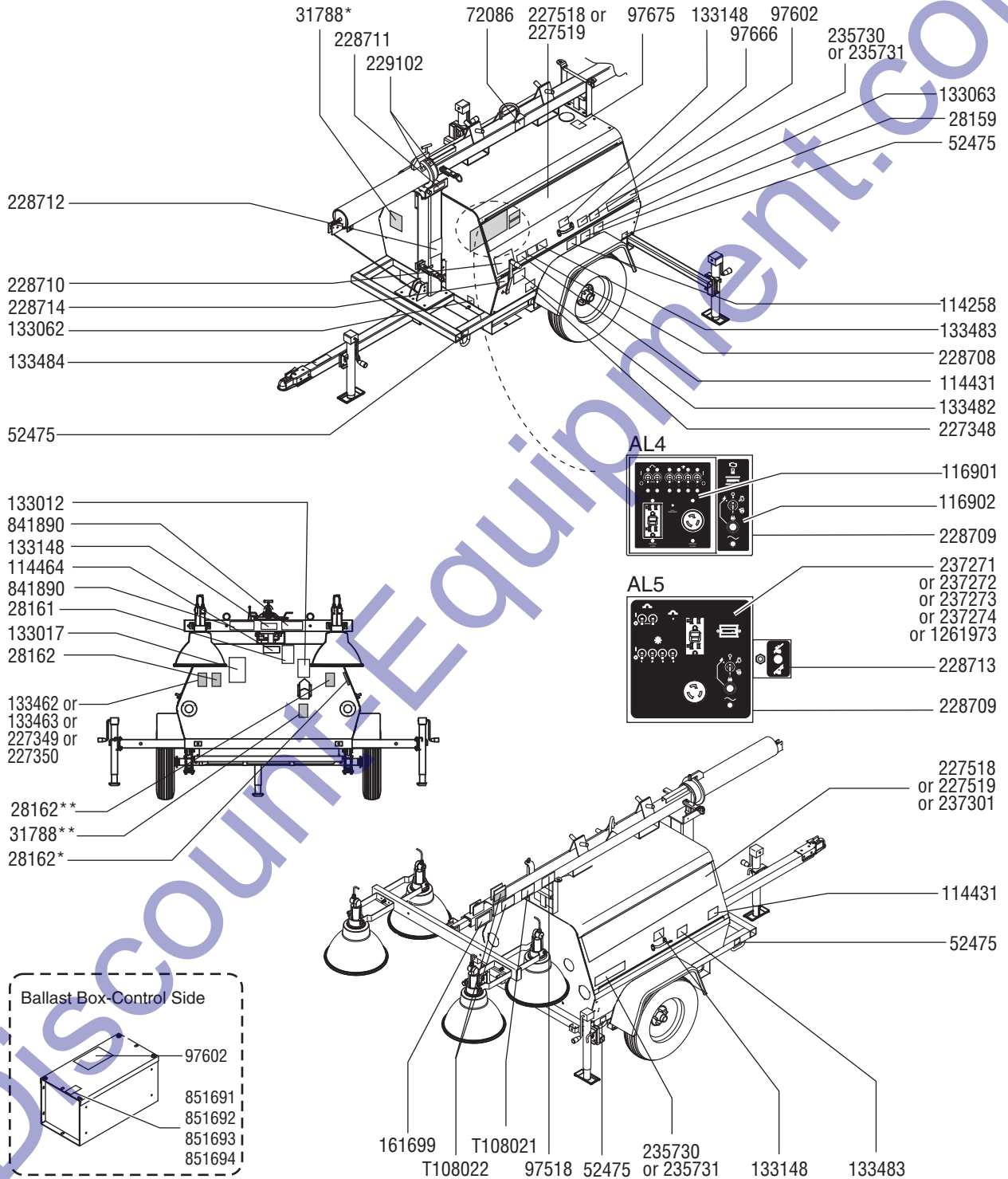

Inspections

Inspection for Decals with Symbols

Determine whether the decals on your machine have words or symbols. Use the appropriate inspection to verify that all decals are legible and in place.

Part No.	Decal Description	Qty
28159	Label – Diesel	1
52475	Label – Transport Tie-down	4
72086	Label – Lifting Point	2
82472	Label – Crushing Hazard	1
82481	Label – Battery/Charger Safety	1
82487	Label – Read the Manual	1
133042	Label – Burn Hazard, Hot Components	1
114251	Label – Explosion Hazard	1
114391	Label – Bodily Injury Hazard	2
116893	Label – Tow Speed	1
116895	Label – Tip-over Hazard, Outriggers	1
116901	Label – AC Control Panel, AL4	1
116902	Label – Engine Control Panel, AL4	1
133031	Label – Burn Hazard	2
133055	Label – Burn/Carbon Monoxide Hazard	1
133062	Label – Ground	1
133063	Label – Transport Diagram	1
133065	Label – Electrocutation Hazard	2
133066	Label – Crushing Hazard	1

Part No.	Decal Description	Qty
133149	Label – Electrocutation Hazard	2
161700	Label – Electrocutation Hazard	1
227518	Cosmetic – Terex Logo, AL4	2
227519	Cosmetic – Terex Logo, AL5	2
229781	Label – Crush Hazard, Mast	1
229782	Label – Crush Hazard	1
228713	Label – Electric Winch Switch	1
228714	Label – Manual Winch	1
229102	Label - Arrow	2
235730	Cosmetic – AL4	2
235731	Cosmetic – AL5	2
237271	Label – AL5 Control Panel, 8 kW	1
237272	Label – AL Control Panel, 12 & 20 kW	1
237273	Label – AL Control Panel, 20 kW, External Power	1
237274	Label – AL Control Panel, 12 kW, External Power	1
841890	Conspicuity Tape	2
851691	Label – #1	1
851692	Label – #2	1
851693	Label – #3	1
851694	Label – #4	1
1261973	Label – AL Control Panel, 20 kW Tier 4	1
T108023	Label – Bodily Injury Hazard	1
T108024	Label – Burn Hazard	2

■ Shading indicates decal is hidden from view, i.e. under covers

Inspections

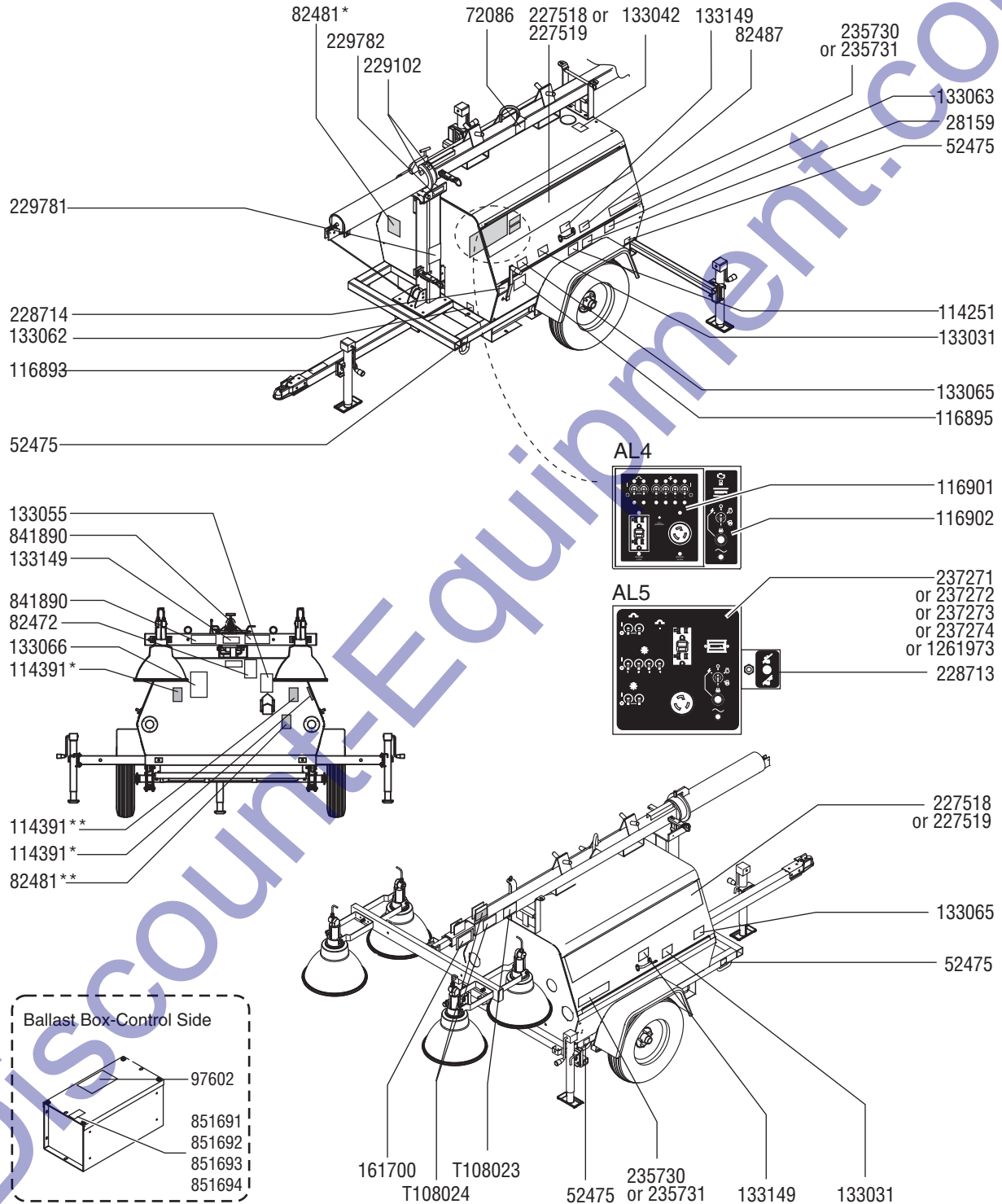

Operating Instructions



Do Not Operate Unless:

- You learn and practice the principles of safe machine operation contained in this operator's manual.
 - 1 Avoid hazardous situations.
 - 2 Always perform a pre-operation inspection.
 - 3 Always perform function tests prior to use.
 - 4 Inspect the workplace.
 - 5 **Only use the machine as it was intended.**

Fundamentals

The Operating Instructions section provides instructions for each aspect of machine operation. It is the operator's responsibility to follow all the safety rules and instructions in the operator's, safety and responsibilities manuals.

Only trained and authorized personnel should be permitted to operate a machine. If more than one operator is expected to use a machine at different times in the same work shift, they must all be qualified operators and are all expected to follow all safety rules and instructions in the operator's, safety and responsibilities manuals. That means every new operator should perform a pre-operation inspection, function tests, and a workplace inspection before using the machine.

Operating Instructions

Setup

Make sure the machine is set up according to the Setup procedure in the Function Test section.

Starting the Engine

Note: The main circuit breaker and the light switches must be off before starting the engine.

Note: There must be fuel in the fuel tank in order to start the engine.

Note: If the machine is equipped with dual fuel tanks, there must be fuel in both tanks in order to start the engine.

Note: On Tier 4 option machines, low fuel will disable the starter.

Engine Start - Without Tier 4 Option

- 1 Turn the ignition switch to the prime position and hold the engine prime button down to prime the engine.
- 2 Hold the prime button down and turn the ignition switch to the start position to start the engine.
- 3 Release the prime button when the engine starts.

Engine Start - With Tier 4 Option

- 1 Flip the Hi/Lo toggle to the Lo position.
- 2 Turn the ignition to the on position.
- 3 Wait ten seconds then turn the ignition switch to the start position.

Raising the Mast

- 1 Remove the retaining pin and the travel lock pin from the top of the mast.
- 2 Manual Winch: Turn the winch handle clockwise until the lower retaining bar locks into the mast.

Electric Winch: Move the raise/lower switch up until the lower retaining bar locks into the mast.

- 3 Insert the retaining pin into the lower retaining bar before extending the mast.

Extending the Mast

- 1 Remove the retaining pin and pull the upper retaining bar.
- 2 Manual Winch: Turn the extend/retract winch handle clockwise to extend mast sections.

Electric Winch: Move the raise/lower switch up.

Attention: Stop extending the mast when red is visible on mast. Continuing to extend the mast when red is visible can result in machine damage.

Retracting the Mast

- 1 Rotate the mast to align the arrows on the mast before retracting.
- 2 Manual Winch: Turn the winch handle counterclockwise until the upper retaining bar locks into the mast and no red line is visible on the mast.

Electric Winch: Move the raise/lower switch down until the upper retaining bar locks into the mast and no red line is visible on the mast.

Operating Instructions

Lowering the Mast

- 1 When the mast sections are fully retracted, pull the lower retaining bar.
- 2 Manual Winch: Turn the winch handle counterclockwise.
Electric Winch: Move the raise/lower switch down.
- 3 When mast is fully lowered into the travel lock, insert the travel lock pin and retaining pin.

Rotating the Mast

- 1 Turn the T-handle to release the mast rotation lock.
- 2 Rotate the mast to the desired position.
- 3 Tighten the T-handle to secure the mast in the desired position.
- 4 Before retracting the mast, rotate mast to align arrows on mast.

Operation of Lights

Note: The engine must be running before the lights are turned on.

Note: On Tier 4 option machines, Hi/Lo switch must be in the Hi position before lights are turned on.

- 1 Be sure the position of the lights is adjusted before raising the mast.
- 2 Start the engine
- 3 Turn on the main circuit breaker switches on the control panel.
- 4 Turn on the lights using the individual light switches.

Note: Lights can take up to 20 minutes to reach full intensity. If the lights are turned off and turned back on again while still warm, they will not light up again for 20 to 30 minutes.

- 5 Turn the lights off by turning the circuit breaker switches to the off position.
- 6 Make sure the lights are turned off before engine is shut down.

Operating Instructions

Grounding Lug

A grounding rod is located inside the door on the road side of the machine.

Drive the rod into the ground and connect it to the grounding lug located on the chassis near the base of the tower.



Electrical Outlets (if equipped)

Electrical outlets are located on the control panel.

Air Shutoff System (if equipped)

Manual air shutoff system

- 1 To shut off the engine, pull the red pull handle on the front of the machine.

Automatic air shutoff system

- 1 The engine will automatically shut off when the engine rpm setting is reached.
- 2 If needed, push in the air shutoff system Emergency Stop button located on the front of the machine.
- 3 To reset the system, remove the machine from the fuel-rich environment.
- 4 Pull out the Emergency Stop button on the front of the machine.

After Each Use

Select a safe parking location—firm level surface, clear of obstruction and traffic. Retract and lower mast and stow outriggers before moving machine.

Remove the key or lock cabinet door.

Towing

- 1 **CAUTION: SHUT ENGINE OFF BEFORE MOVING THE LIGHT TOWER! Failure to do so can cause severe engine/radiator damage and WILL NOT BE COVERED UNDER WARRANTY!**
- 2 Fully retract and lower the mast to the stowed position.
- 3 Lower the light bar to the stowed position.
- 4 Make sure the travel lock pin is securely locked in place.
- 5 Make sure the covers are closed and secured.
- 6 Pull the spring pins on each outrigger and slide them into the stowed and secured position..
- 7 Raise the tongue of the machine by turning the tongue jack handle.
- 8 Position the transport vehicle under the coupler on the tongue of the machine.
- 9 Open the latch on the coupler.
- 10 Turn the tongue jack handle to lower the tongue.
- 11 Close the latch on the coupler.
- 12 Rotate the tongue jack to the stowed position and secure with the lock pin.
- 13 Attach safety chains.
- 14 Connect and test the trailer lights.

Operating Instructions

Towing Information

Driving a vehicle/trailer combination is different from driving a vehicle alone.

Inspect all connections at each stop.

All tires must be properly inflated. Do not overinflate the tires. Tire pressures go up during driving. Checking the tire pressure when the tires are warm will give you an inaccurate pressure reading.

Increase the distance between your vehicle and the vehicle in front of you to twice the normal following distance when towing a trailer. Allow more following distance in adverse weather.

Slow down for downgrades and shift your transmission into a lower gear.

Slow down for curves, hazardous road conditions, freeway exits, and when driving in adverse weather.

Heavy winds, excessive speed, load shifting or passing vehicles can cause a trailer to sway while driving. If this occurs, do not brake, speed up or turn the steering wheel. Turning the steering wheel or applying the brakes can cause the vehicle and trailer to jackknife. Let up on the gas pedal and keep the steering wheel straight.

If the vehicle and/or trailer travels off the paved road, hold the steering wheel firmly and let up on the gas pedal. Do not apply the brakes. Do not turn sharply. Slow down to under 25 mph / 40 km/h. Gradually turn the steering wheel to get back on the road. Proceed with caution when entering traffic.

When passing other vehicles, be sure to leave enough room for the extra length of the trailer. You will need to go much farther beyond the passed vehicle before you can return to your lane.

Avoid sudden movements when turning.

Transport and Lifting Instructions



Observe and Obey:

- ☑ Terex Corporation provides this securement information as a recommendation. Drivers are solely responsible for making sure machines are properly secured and the correct trailer is selected pursuant to US Department of Transportation regulations, other localized regulations, and their company policy.
- ☑ Terex customers needing to containerize any Terex product should source a qualified freight forwarder with expertise in preparing, loading and securing construction and lifting equipment for international shipment.
- ☑ The transport vehicle must be parked on a level surface.
- ☑ The transport vehicle must be secured to prevent rolling while the machine is being loaded.
- ☑ Be sure the vehicle capacity, loading surfaces and chains or straps are sufficient to withstand the machine weight. See the serial label for the machine weight.
- ☑ Common sense and planning must be applied to control the movement of the machine when lifting it with a crane or forklift.

Securing to Truck or Trailer for Transit

Fully retract and lower the mast to the stowed position.

Secure the mast for transport with the travel lock pin.

Fully retract, raise and lock all tongue jacks and outriggers.

Close and secure the cabinet doors.

Inspect the entire machine for loose or unsecured items.

Use the four tie-down points for anchoring down to the transport surface.

Use a minimum of four chains to secure the light tower.

Adjust the rigging to prevent damage to the chains.

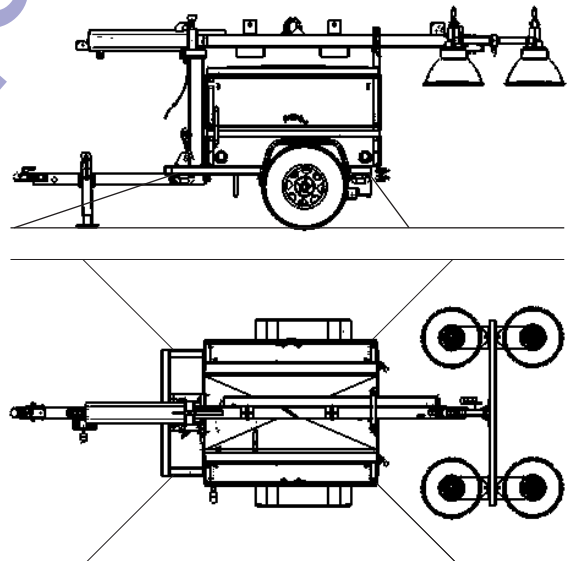

Transport and Lifting Instructions



Observe and Obey:

- ☑ Only qualified riggers should rig the machine.
- ☑ Only certified crane operators should lift the machine and only in accordance with the applicable crane regulations.
- ☑ Be sure the crane capacity, loading surfaces and straps or lines are sufficient to withstand the machine weight. See the serial label for the machine weight.

Lifting the Machine with a Crane

Fully retract and lower the mast to the stowed position.

Secure the mast for transport with the travel lock pin.

Fully retract, raise and lock all tongue jacks and outriggers.

Close and secure the cabinet doors.

Use the lifting eye on the mast to lift the machine.

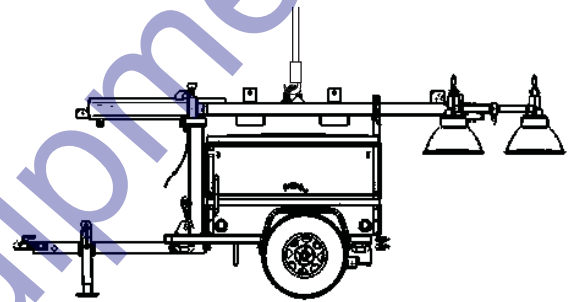

Maintenance



Observe and Obey:

- ☑ Only routine maintenance items specified in this manual shall be performed by the operator.
- ☑ Scheduled maintenance inspections shall be completed by qualified service technicians, according to the manufacturer's specifications and the requirements specified in the responsibilities manual.
- ☑ Use only Terex approved replacement parts.

Maintenance Symbols Legend

The following symbols have been used in this manual to help communicate the intent of the instructions. When one or more of the symbols appear at the beginning of a maintenance procedure, it conveys the meaning below.



Indicates that tools will be required to perform this procedure.



Indicates that new parts will be required to perform this procedure.

Check the Engine Oil Level



Maintaining the proper engine oil level is essential to good engine performance and service life. Operating the machine with an improper oil level can damage engine components.

Note: Check the oil level with the engine off.

- 1 Check the oil level dipstick. Add oil as needed.

Perkins 403D-11G Engine

Oil type	10W-30
Oil type - cold conditions	5W-20

Kubota D-1105 Engine

Oil type	10W-30
Oil type - cold conditions	5W-20

Kubota V-1505 Engine

Oil type	10W-30
Oil type - cold conditions	5W-20

Isuzu 4LE2 & 4LE2-T

Oil type	10W-30
Oil type - cold conditions	5W-20

Maintenance

Check the Engine Coolant Level



Maintaining the engine coolant at the proper level is essential to engine service life. Improper coolant level will affect the engine's cooling capability and damage engine components. Daily checks will allow the inspector to identify changes in coolant level that might indicate cooling system problems.

- ▲ Burn hazard. Beware of hot engine parts and coolant. Contact with hot engine parts and/or coolant may cause severe burns.

Note: Do not remove the radiator cap.

- 1 Check the fluid level in the coolant recovery tank. Add fluid as needed.
- ⊙ Result: The fluid level should be at the FULL mark.

Refer to Kubota Operator's Manual 97897-01090.

Check the Batteries



Proper battery condition is essential to good machine performance and operational safety. Improper fluid levels or damaged cables and connections can result in component damage and hazardous conditions.

- ▲ Electrocutation hazard. Contact with hot or live circuits may result in death or serious injury. Remove all rings, watches and other jewelry.
 - ▲ Bodily injury hazard. Batteries contain acid. Avoid spilling or contacting battery acid. Neutralize battery acid spills with baking soda and water.
- 1 Put on protective clothing and eye wear.
 - 2 Be sure that the battery cable connections are tight and free of corrosion.
 - 3 Be sure that the battery hold-down brackets are in place and secure.

Note: Adding terminal protectors and a corrosion preventative sealant will help eliminate the corrosion on the battery terminals and cables.

Maintenance

Check the Tires and Wheels



- ▲ Bodily injury hazard. An over-inflated tire can explode and may cause death or serious injury.
- ▲ Collision hazard. An excessively worn tire can cause poor handling and continued use could result in tire failure.
- ▲ Tip-over hazard. Do not use temporary flat tire repair products.

Maintaining the tires and wheels in good condition is essential to safe operation and good performance. Tire and/or wheel failure could result in a machine tip-over. Component damage may also result if problems are not discovered and repaired in a timely fashion.

- 1 Check the tire surface and sidewalls for cuts, cracks, punctures and uneven or excessive tread wear. Replace the tire if uneven or excessive tread wear is found.
- 2 Check each wheel for damage, bends and cracks. Replace the wheel if any damage is found.

Note: Tires and wheels must be replaced with tires and wheels of the specifications listed.

- 3 Check each tire with an air pressure gauge. Add air as needed.
- 4 Check the torque of each lug nut.

Tire Specifications, U.S.

Tire Size	ST205/75R15	Load C
Lug nut torque	90 ft/lbs	122 Nm
Tire pressure (cold)	50 psi	3.4 bar

Scheduled Maintenance

Maintenance performed quarterly, annually and every two years must be completed by a person trained and qualified to perform maintenance on this machine according to the procedures found in the service manual for this machine.

Machines that have been out of service for more than three months must receive the quarterly inspection before they are put back into service.

Specifications

AL4

Height, stowed	5 ft 8 in	1.73 m
Length, stowed	14 ft 11 in	4.55 m
Width, stowed	5 ft 8 in	1.73 m
Extended mast height	30 ft	9.14 m
Total weight, no fuel	1950 lbs	885 kg
(Machine weights vary with option configurations. See serial label for specific machine weight.)		
Tongue weight	100 lbs	45 kg
Tire size, U.S.	ST205/75D15	Load C
Engine type	Kubota	13.5 HP
	Perkins	13.8 HP
Fuel capacity, standard	30 gallons	114 liters
Fuel capacity, option	50 gallons	189 liters
Run time, standard		
(30 gallon tank-Kubota D1105-Full load)	34.48 hrs	
Generator options	Marathon 6 kW, 60 Hz	
	Marathon 7 kW, 50 Hz	
	Marathon 8 kW, 60 Hz	
Total lighting wattage		
Four lights	4000 watts	
Replacement bulbs	1000 watts	
	Type BT-37 Metal Halide	
Tower rotation	359 degrees	
	non-continuous	
Maximum towing speed	60 mph	97 km/h
Maximum wind speed	62 mph	100 km/h
Sound level (dba rating)	71 dba @	23 ft / 7 m

Continuous improvement of our products is a Terex policy. Product specifications are subject to change without notice or obligation.

AL5

Height, stowed	5 ft 9 in	1.75 m
Length, stowed	15 ft 3 in	4.65 m
Width, stowed	6 ft 9 in	2.06 m
Extended mast height	30 ft	9.14 m
Total weight, no fuel	2239 lbs	1016 kg
(Machine weights vary with option configurations. See serial label for specific machine weight.)		
Tongue weight	220 lbs	100 kg
Tire size, U.S.	ST205/75D15	Load C
Engine type		
	Kubota	13.5 hp
8 kW		
	Kubota	18.04 hp
12 kW		
	Isuzu	34.5 hp
20 kW		
Fuel capacity, standard	30 gallons	114 liters
Fuel capacity, option	60 gallons	227 liters
Run time, standard unit		
(30 gallon tank-Kubota D1105-Full load)	34.48 hrs	
Generator options	Marathon 8 kW, 60 Hz	
	Marathon 12 kW, 60 Hz	
	Marathon 20 kW, 60 Hz	
Total lighting wattage		
Four lights	4000 watts	
Replacement bulbs	1000 watts	
	Type BT-37 Metal Halide	
Tower rotation	359 degrees	
	non-continuous	
Maximum towing speed	60 mph	97 km/h
Maximum wind speed	62 mph	100 km/h
Sound level (dba rating)	71 dba @	23 ft / 7 m

Continuous improvement of our products is a Terex policy. Product specifications are subject to change without notice or obligation.

Reporting Safety Defects

Terex
18340 NE 76th Street
PO Box 97030
Redmond, WA 98073-9730

Reporting Safety Defects

If you believe that your vehicle has a defect which could cause a crash or could cause injury or death, you should immediately inform the National Highway Traffic Safety Administration (NHTSA) in addition to Terex Corporation.

If NHTSA receives similar complaints, it may open an investigation, and if it finds that a safety defect exists in a group of vehicles, it may order a recall and remedy campaign. However, NHTSA cannot become involved in any individual problems between you, your dealer or Terex Corporation.

To contact NHTSA you may either call the Auto Safety Hotline toll-free at 1-800-424-9393 (366-0123 in Washington DC area) or write to:

NHTSA
U.S. Department of Transportation
400 7th Street SW, (NSA-11)
Washington DC 20590

You can also obtain information about motor vehicle safety from the Hotline.

California Proposition 65

Warning

The exhaust from this product contains chemicals known to the State of California to cause cancer, birth defects or other reproductive harm.

Towing Checklist (Use at each stop)

Before Towing

- All covers are closed and jacks, outriggers, and mast are locked and secured in the travel position.
- Towing hitch is properly secured to tow vehicle
- Safety chains are properly attached and secure (chains are crossed below hitch)
- All lights are connected and working
- Tires are properly inflated

Before Driving

- Fasten safety restraints
- Properly adjust mirrors

On The Road

- Do not exceed 60 mph / 97 km/h. Obey all local and national towing speed laws
- Check connections and tire pressure at each stop
- Slow down for hazardous conditions
- Allow extra distance for following and passing other vehicles