

HEATER SYSTEM

Burner

- Riello F15 single stage diesel fuel burner
 - Firing rate: 2.55–5.75 gph (9.65–21.77 Lph)
 - Heat produced: 357,000–805,000 BTU/hr (104.6–235.9 kW/hr)
- Temperature range: 120–180 °F (48.9–82.2 °C)

Fan

- Air ducts: Two 12 in (30.5 cm) diameter
- Efficiency: 85%
- Fan motor: TECO 5 hp (3.73 kW) @ 3,600 rpm
- Fan wheel: BC-SW 135 CL II
- Fan performance:
 - 3,900 ft³/m (110.4 m³/min)
 - 5 in. WG (1.24 kPa) static pressure

Heat Exchanger

- Very large 158 ft² surface area
- Dual pass design
- Large combustion air passages to reduce cleaning
- Stainless Steel construction

Safety

- Burner fire eye - shuts off fuel pump if no flame is present in burner
- Air differential switch - shuts off burner if no air flow is present
- High Limit Switch - shuts off burner if air temperature exceeds 200 °F (90 °C)

FUEL SYSTEM

- Fuel tank capacity—gal (L):
 - Total: 200 (757.1)
 - Usable: 173 (654.9)
- Fuel consumption rate (engine + burner): 6.25 gph (23.7 Lph)
- Minimum run time: 27.7 hr
- Fuel filter: Two Spin-on; one for engine and one for burner

GENERATOR

Engine

- Isuzu® 3CE1-UGZG1 3 cylinder
- Diesel fueled
- EPA Final Tier 4
- Naturally aspirated
- 97.6 in³ (1.6 L) displacement



Picture shown may not reflect actual configuration.

- Power @ 1,800 rpm: 21.1 hp (15.7 kW)
- Air filter: dry type cartridge
- Engine Coolant Heater 110V

Cooling System

- Liquid cooled
- Coolant capacity: 2.1 qt (2.0 L)
- Capable of operating at -40 to 100 °F (-40 to 37.8 °C) ambient – not considering derate factors

Lubrication System

- Oil capacity: 7.1 qt (6.7 L)
- 250-hr service interval*

*For maximum service interval, replace oil filter after 50-hr break-in period. For oil filter model number, see parts manual.

Battery

- One GRP24 12V, 720 CCA, wet cell battery

Alternator

- Marathon® 282CSL1504
- 13.5 kW 208V 3-Phase
- 20 Amp 110V external outlet

CONTROLS

- LOFA® MC704 engine control panel
- Pushbutton start fan control
- Programmable thermostat
- Wiring harness with circuit breakers: 20-amp outlet breaker, 20-amp burner breaker

ENCLOSURE

- Material: Steel with white durable Polyester 5 stage powder coat
- Construction: Sectional roof and side panels are replaceable
- Lockable control box door and service access doors
- Rear internal storage for air ducts
- Operating and safety decals
- Document holder with owner's manual and wiring diagrams

TRAILER

- 2-5/16 in. ball hitch—adjustable height
- Tongue jack and transportation tie downs
- Electric brakes
- Forklift tubes: integrated forklift tubes extend to fenders to prevent forklift damage
- DOT and TC approved lights: Tail, brakes, and directionals
- One 6,000 lb. (2,721.6 kg) axle with 235 80/R16 10 ply load range E tires

OPTIONS*

- Spare tire and carrier
- Rear stabilizer jacks
- 1×20 in (50.8 cm) duct outlet
- 2-5/16 in. BULLDOG® hitch – adjustable height
- 3 in. Pintle ring – adjustable
- Fuel filter heaters

*Additional options may be available. Contact a sales representative or the factory for current options.

DIMENSIONS

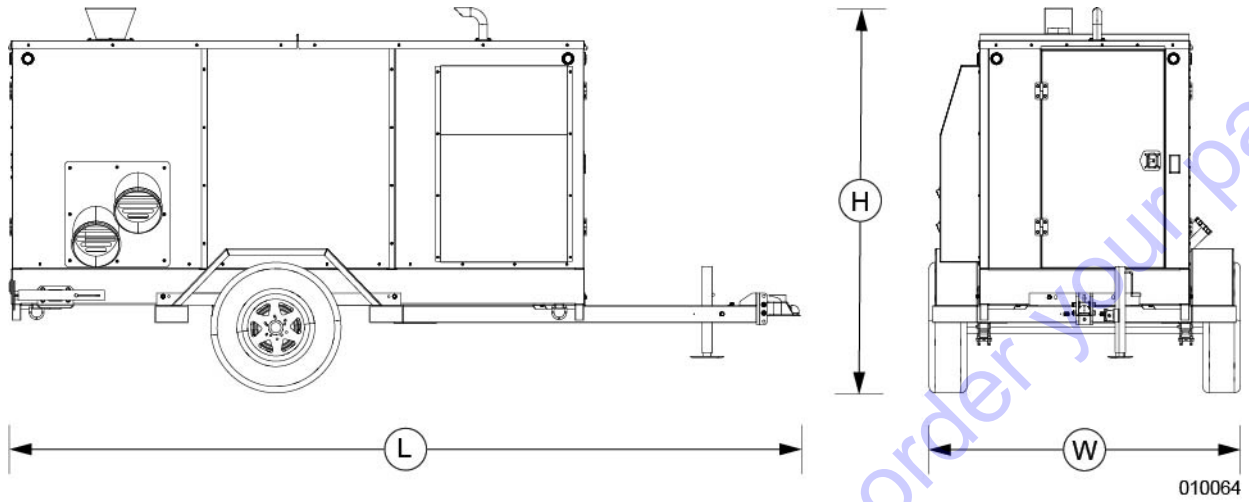

L	W	H
186 in (4.72 m)	72.0 in (1.83 m)	91.3 in (2.32 m)

WEIGHT

- Dry: 4,900 lb (2,223 kg)
- Operating: 6,080 lb (2,758 kg)

WARRANTY

1 year, unlimited hours

CODES AND STANDARDS

Generac Mobile products are designed to the following standards:



TIER 4 FINAL EMISSIONS



NATM



TRANSPORT CANADA



www.discount-equipment.com

TO PURCHASE THIS PRODUCT PLEASE CONTACT US



**Equipment Financing and
Extended Warranties Available**



**Discount-Equipment.com is your online resource for
commercial and industrial quality parts and equipment sales.**

561-964-4949

visit us on line @ www.discount-equipment.com

Select an option below to find your Equipment

Search by Manufacturer

Search by Product Type

Request a Quote

We sell worldwide for the brands: Genie, Terex, JLG, MultiQuip, Mikasa, Essick, Whiteman, Mayco, Toro Stone, Diamond Products, Generac Magnum, Airman, Haulotte, Barreto, Power Blanket, Nifty Lift, Atlas Copco, Chicago Pneumatic, Allmand, Miller Curber, Skyjack, Lull, Skytrak, Tsurumi, Husquvarna Target, Stow, Wacker, Sakai, Mi-T-M, Sullair, Basic, Dynapac, MBW, Weber, Bartell, Bennar Newman, Haulotte, Ditch Runner, Menegotti, Morrison, Contec, Buddy, Crown, Edco, Wyco, Bomag, Laymor, EZ Trench, Bil-Jax, F.S. Curtis, Gehl Pavers, Heli, Honda, ICS/PowerGrit, IHI, Partner, Imer, Clipper, MMD, Koshin, Rice, CH&E, General Equipment, Amida, Coleman, NAC, Gradall, Square Shooter, Kent, Stanley, Tamco, Toku, Hatz, Kohler, Robin, Wisconsin, Northrock, Oztec, Toker TK, Rol-Air, APT, Wylie, Ingersoll Rand / Doosan, Innovatech, Con X, Ammann, Mecalac, Makinex, Smith Surface Prep, Small Line, Wanco, Yanmar