

ENGINE SYSTEM

- Perkins® 120AF-E44TTA
- Diesel fueled
- EPA Final Tier 4
- 4 cylinder
- Series turbocharged
- 4.4 L (268.5 in³) displacement
- Power @ 2,200 rpm: 150 hp (112 kW)
- 110% containment

Fuel System

- Fuel tank capacity—gal (L):
 - Total: 200 (757.1)
 - Usable: 176 (654.9)
- Fuel consumption rate: 7.9 gph (29.9 Lph)
- Minimum run time: 26 hr
- Fuel filter: Spin-on
- DEF tank capacity—gal (L):
 - Total: 10 (38)
 - Usable: 8 (30)
- DEF consumption rate: 0.312 gph (1.18 Lph)
- DEF and fuel sized for a 1:1 fill ratio

Cooling System

- Liquid cooled
- Capable of operating at -40 to 70 °F (-40 to 21.1 °C) ambient—not considering derate factors
- Coolant capacity: 10.3 qt (9.75 L)

Lubrication System

- Oil filter: Spin-on
- 500-hr service interval**

**Data based on engine manufacturer and field test data after 100-hr engine break-in period. Actual results may vary, according to factors such as age and maintenance of equipment, environmental conditions, and fuel density. For fuel and maintenance recommendations, see owner's manual.*

***For maximum service interval, replace oil filter after 50-hr break-in period. For oil filter model number, see owner's manual.*

HEATER

- Type: Flameless, self-contained
- Heat produced: Up to 875,000 BTU/hr (256.4 kW/hr)
- Temperature range: 120–180 °F (48.9–82.2 °C)
- Air flow: 3,500–5,000 ft³/min (99.1–141.6 m³/min)
- Air ducts: Two 12 in (30.5 cm) diameter
- Efficiency: 88%
- Heat transfer fluid (HTF):
 - Tank capacity: 14 gal (53 L)
 - System capacity: 20.6 gal (77.9 L)
 - Hydraulic oil type: Mobile DTE10 ISO VG68



Picture shown may not reflect actual configuration.



HYDRAULIC LOOP

- Pump: Rexroth 100 cc variable displacement piston pump
- Two 10-micron hydraulic oil filters

SAFETY

- Emergency stop switch
- Positive air shutdown
- Self-contained
- Automatic shutdown for high hydraulic oil temperature, high hydraulic oil pressure, engine overspeed, low engine oil, low fuel, and low hydraulic oil

ENCLOSURE

- Material: Aluminum with powder coat
- Fully lockable – including control box door, service access doors, fuel fill, and DEF fill
- Rear storage for two 12-in×50-ft air ducts
- Operating and safety decals
- Document holder with owner's manual – includes DC wiring diagrams

TRAILER

- 2-5/16 in ball hitch—adjustable height
- Lift jack
- Electric brakes
- Transportation tie downs
- Forklift tubes
- DOT approved lights: Tail, brakes, and directionals
- One 8,000 lb (3,638.7 kg) axle
- Tires: 16 in (40.6 cm)

CONTROLS

- Wachendorf® controller and display
- TFT color graphic LCD display with LED backlight
- Operating temperature range: -22 to 149 °F (-30 to 65 °C)

BATTERIES

- Two 12 V, 950 CCA, wet cell batteries

OPTIONS*

- Block heater
- Fire extinguisher
- Hitch
- Spare tire and carrier
- Duct outlet diameter
- Heated fuel filter
- 60/40 coolant
- Rear stabilizer jacks

**Additional options may be available. Contact a sales representative or the factory for current options.*



www.discount-equipment.com

DIMENSIONS

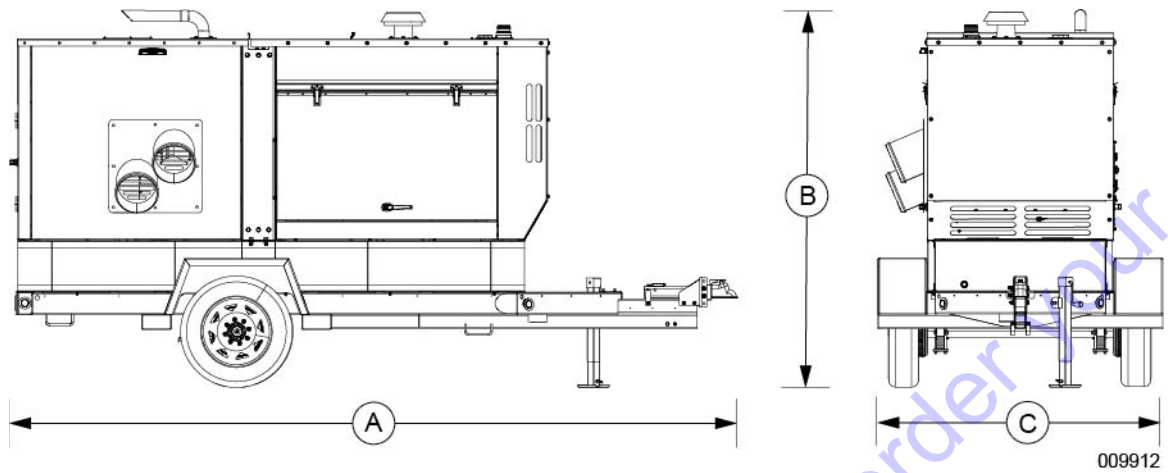

A	B	C
192.25 in (4.88 m)	94.25 in (2.39 m)	76.5 in (1.94 m)

WEIGHT

- Dry: 6,590 lb (2,992 kg)
- Operating: 7,735 lb (3,512 kg)

WARRANTY

1 year, unlimited hours

CODES AND STANDARDS

Generac Mobile products are designed to the following standards:



TIER 4 FINAL
EMISSIONS



NATM



TRANSPORT CANADA



www.discount-equipment.com

TO PURCHASE THIS PRODUCT PLEASE CONTACT US



**Equipment Financing and
Extended Warranties Available**



**Discount-Equipment.com is your online resource for
commercial and industrial quality parts and equipment sales.**

561-964-4949

visit us on line @ www.discount-equipment.com

Select an option below to find your Equipment

Search by Manufacturer

Search by Product Type

Request a Quote

We sell worldwide for the brands: Genie, Terex, JLG, MultiQuip, Mikasa, Essick, Whiteman, Mayco, Toro Stone, Diamond Products, Generac Magnum, Airman, Haulotte, Barreto, Power Blanket, Nifty Lift, Atlas Copco, Chicago Pneumatic, Allmand, Miller Curber, Skyjack, Lull, Skytrak, Tsurumi, Husquvarna Target, Stow, Wacker, Sakai, Mi-T-M, Sullair, Basic, Dynapac, MBW, Weber, Bartell, Bennar Newman, Haulotte, Ditch Runner, Menegotti, Morrison, Contec, Buddy, Crown, Edco, Wyco, Bomag, Laymor, EZ Trench, Bil-Jax, F.S. Curtis, Gehl Pavers, Heli, Honda, ICS/PowerGrit, IHI, Partner, Imer, Clipper, MMD, Koshin, Rice, CH&E, General Equipment, Amida, Coleman, NAC, Gradall, Square Shooter, Kent, Stanley, Tamco, Toku, Hatz, Kohler, Robin, Wisconsin, Northrock, Oztec, Toker TK, Rol-Air, APT, Wylie, Ingersoll Rand / Doosan, Innovatech, Con X, Ammann, Mecalac, Makinex, Smith Surface Prep, Small Line, Wanco, Yanmar