

OWNERS MANUAL

INSTALLATION AND OPERATION INSTRUCTIONS

35PTOC-3

40PTOC-4

45PTOC-17

50PTOC-3

75FPTOC-4

75FPTOC-17

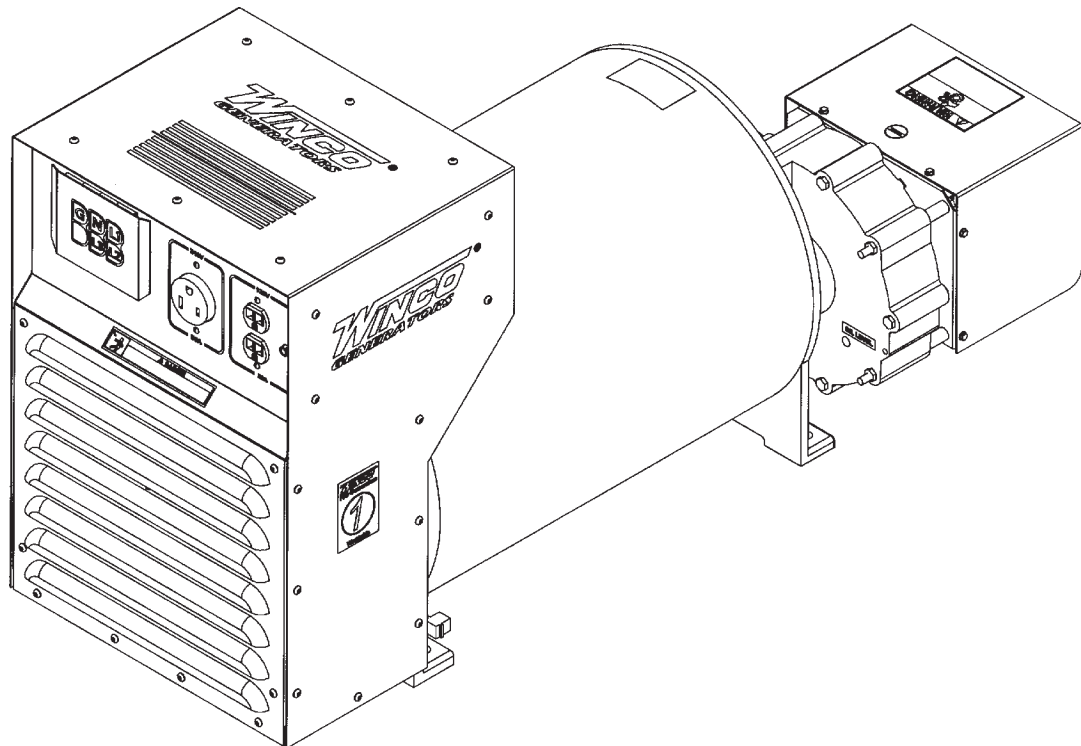

75FPTOC-17

SAFETY FIRST

READ THIS MANUAL BEFORE OPERATING YOUR GENERATOR.

Read and understand all instructions in this manual before starting and operating the generator set.

USING THIS MANUAL

Congratulations on your choice of a Winco generator set. You have selected a high-quality, precision-engineered generator set designed and tested to give you years of satisfactory standby service.

To get the best performance from your new generator set, it is important that you carefully read and follow the operating instructions in this manual.

Should you experience a problem please follow the "Things To Check" near the end of this manual. The warranty listed in this manual describes what you can expect from WINCO should you need service assistance in the future.

TABLE OF CONTENTS

INTRODUCTION	i
GUIDE TO PRODUCT SAFETY	1
BASIC INFORMATION	
Unit Capabilities	2
PREPARING THE UNIT	2
Unpacking the unit	2
Assembly	2
INSTALLATION	
Foundation Mounting	3
Trailer Mounting	3
ELECTRICAL CONNECTIONS	4
OPERATION	5
Pre-Start Checks	5
Starting Procedure	6
Stopping	6
MAINTENANCE	7
Lubrication	7
Cleaning	8
Storage	8
Trouble Shooting Table	8
36 MONTH WARRANTY	10

PROPER USE AND INSTALLATION

You must be sure your new generator set is:

- * Properly serviced before operating
- * Operated in a well ventilated area
- * Exhaust gases are dispersed safely
- * Wired by a qualified electrician
- * Operated only for its designed purposes
- * Used only by operators who understand its operation
- * Properly maintained

COPY YOUR MODEL AND SERIAL NUMBER HERE

No other WINCO generator has the same serial number as yours. It is important that you record the number and other vital information here, if you should ever need to contact us on this unit it will help us to respond to your needs faster.

MODEL _____

SERIAL NUMBER _____

PURCHASE DATE _____

DEALER _____

SAFETY INFORMATION

This generator set has been designed and manufactured to allow safe, reliable performance. Poor maintenance, improper or careless use can result in potential deadly hazards; from electrical shock, exhaust gas asphyxiation, or fire. Please read all safety instructions carefully before installation or use. Keep these instructions handy for future reference. Take special note and follow all warnings on the unit labels and in the manuals.

ANSI SAFETY DEFINITIONS

DANGER:

DANGER indicates an imminently hazardous situation which, if not avoided, will result in death or serious injury. This signal word is to be limited to the most extreme situations.

WARNING:

WARNING indicates a potentially hazardous situation which, if not avoided, could result in death or serious injury.

CAUTION:

CAUTION indicates a potentially hazardous situation which, if not avoided, may result in minor or moderate injury. It may also be used to alert against unsafe practices.

NOTE:

CAUTION is also used on the unit labels and in this manual to indicate a situation that could result in serious damage or destruction of the equipment and possible personal injury.

1. **ELECTRIC SHOCK-** The output voltage present in this equipment can cause a fatal electric shock. This equipment must be operated by a responsible person.
 - a. Do not allow anyone to operate the generator without proper instruction.
 - b. Guard against electric shock.
 - c. Avoid contact with live terminals or receptacles.
 - d. Use extreme care if operating this unit in rain or snow.
 - e. Use only three-prong grounded plugs and extension cords.
 - f. Be sure the unit is properly grounded to an external ground rod driven into the earth.
 - g. Do not make or break electrical connection under load.
2. **FIRE HAZARD-** Gasoline, diesel and other fuels always present a hazard of possible explosion and/or fire.
 - a. Keep a fire extinguisher nearby and know its proper use. Fire extinguishers rated ABC by NFPA are appropriate.
3. **DEADLY EXHAUST GAS** - Exhaust fumes from any engine contain carbon monoxide, an invisible, odorless and deadly gas that must be mixed with fresh air.
 - a. Operate only in well ventilated areas.
 - b. Never operate indoors.
4. **NOISE HAZARD** - Excessive noise is not only tiring, but continual exposure can lead to loss of hearing.
 - a. Use hearing protection equipment when working around this equipment for long periods of time.
 - b. Keep your neighbors in mind when permanently installing this equipment.
5. **CLEANLINESS-** Keep the generator and surrounding area clean.
 - a. Remove all grease, ice, snow or materials that create slippery conditions around the unit.
 - b. Remove any rags or other material that could create potential fire hazards.
6. **SERVICING EQUIPMENT-** All service, including the installation or replacement of service parts, should be performed only by a qualified technician.
 - a. Use only factory approved repair parts.
 - b. Do not work on this equipment when fatigued.
 - c. Use extreme caution when working on electrical components. High output voltages from this equipment can cause serious injury or death.
 - d. Always avoid hot mufflers, exhaust manifolds, and engine parts. They all can cause severe burns instantly.
7. **INSTALLATION-** Installing a PTO generator is not a “do-it-yourself” project. Consult a qualified, licensed electrician or contractor. The installation must comply with all national, state, and local codes.
 - a. Never operate the PTO drive generator without having it properly mounted to a concrete base or approved trailer.
 - b. Never connect the PTO generator to an existing electrical system without installing an isolation transfer switch.
 - c. Always insure the drive shaft is straight and level before operating the generator.
8. **OPERATION** - PTO drive shafts (Tumbling Bars) have many inherent dangers, extreme caution must be exercised when using them.
 - a. **NEVER** allow children around a drive shaft when it is in operation.
 - b. Keep all safety guards and shields in place and securely tightened.
 - c. Never operate a drive shaft that has been damaged or had the safety shield removed.
 - d. Never step over a drive shaft while it is running.
 - e. Never wear a necktie, loose articles of clothing, or anything else that can be caught in moving parts.
 - f. Never try to stop a turning drive shaft with your hand or foot.

Description

The WINCO PTO drive generator will provide, depending on the unit purchased, 120/240V single phase, 120/240V three phase or 120/208 three phase 60Hz electrical service when direct-driven. Tractor or vehicle power take-off shafts, can be used for driving these generators.

NOTE: The prime mover which drives the generator must be capable of delivering approximately 2 HP per 1000 watts output from the generator. Observe input RPM specifications.

The generator may be foundation mounted for use as standby power source, or trailer mounted, and used as portable electrical power sources for areas where commercial power is not readily available, such as out buildings.

This generator includes a load sensing transformer which provides extra motor starting power, a color coded voltmeter to warn against high or low voltage, three output power receptacles, an overload protection circuit, and an electronic excitation circuit. To reduce maintenance problems, the coupling between the generator input shaft and rotor consists of precision helical gearing rather than a chain link drive. The input shaft is splined, and is 1-3/8 in diameter.

The factory thoroughly tests each of these generators before shipment. All are continuous duty rated.

IMPORTANT: THE MANUFACTURER STRONGLY RECOMMENDS RUNNING THE GENERATOR UNDER LOAD AT LEAST ONCE A MONTH IN ORDER TO EVAPORATE ANY ACCUMULATED MOISTURE CONDENSATION

UNPACKING

CAUTION: Equipment Damage

DO NOT invert generator during unpacking. The Gearcase contains oil which will leak out if inverted during unpacking.

Unpack the generator as follows:

1. Remove the carton.
2. Examine the unit for damage.
3. Find the small subpack carton packed in the large carton. Be careful not to throw away the subpack carton with the large carton.
4. Open the subpack carton and make sure it contains:
 - a. Generator instruction manual
 - b. Load disconnect plug (disassembled, in bag)
5. Remove the four bolts which hold down the generator feet to the pallet.
6. Lift the generator from the pallet by means of the lifting eye on the top of the generator.
7. Inspect the generator carefully for freight loss or damage. If

loss or damage is noted at time of delivery, require that the person making the delivery make note of the loss or damage on the freight bill, or sign the consigner's memo of the loss or damage. Contact the carrier for claim procedures.

When loss or damage is noted after delivery, segregate the damaged material, and contact the carrier for claim procedures.

"Concealed damage" means damage to the contents of a package which is not evident when the package is delivered by the carrier, but which is discovered later. The carrier or carriers are responsible for merchandise lost or damaged in transit. The title to the goods rests with the consignee when the goods are shipped FOB factory, and only the consignee can legally file claims. Two years are allowed in which to file suit after a claim is disallowed in writing by the carrier.

Specifications

MODEL	VOLTAGE	PHASE	P/F	AMPERAGE
35PTOC-3	120/240	Single	1.0	146
40PTOC-4	120/208	Three	1.0	111
45PTOC17	120/240	Three	1.0	108
50PTOC-3	120/240	Single	1.0	208
75PTOC-4	120/208	Three	1.0	208
75PTOC-17	120/240	Three	1.0	180

Assembly

The only assembly work required after unpacking the generator is to assemble the load disconnect plug, which is contained in a bag in the subpack carton packed in the generator crate.

The bag contains an instruction sheet, 2 plug bodies (3 plug bodies for three phase), four or six contacts with inserts if required, two handle and the hardware to assembly the disconnect plug. You will need to purchase the appropriate length of fine stranded copper wire for your application in order to complete the assembly of the disconnect plug. **DO NOT USE SO CABLE - USE SINGLE LEAD WELDING CABLE**

The following wire sizes are recommended for each unit.

Generator Model	Size AWG	Insulation
35PTOC	#2	Neoprene/THHN
40PTOC	#4	Neoprene/THHN
45PTOC	#4	Neoprene/THHN
50PTOC	#1	Neoprene/THHN
75PTOC	#1	Neoprene/THHN

If you require different inserts or contacts for local code, WINCO has a variety of different inserts and contacts available. Contact the factory at 507-357-6831 for pricing.

WARNING: Equipment Damage

Never use acid core solder. When soldering insure no excess solder runs down on the contact surface - Solder on the contact surface will not allow the contacts to mate properly causing them to burn up.

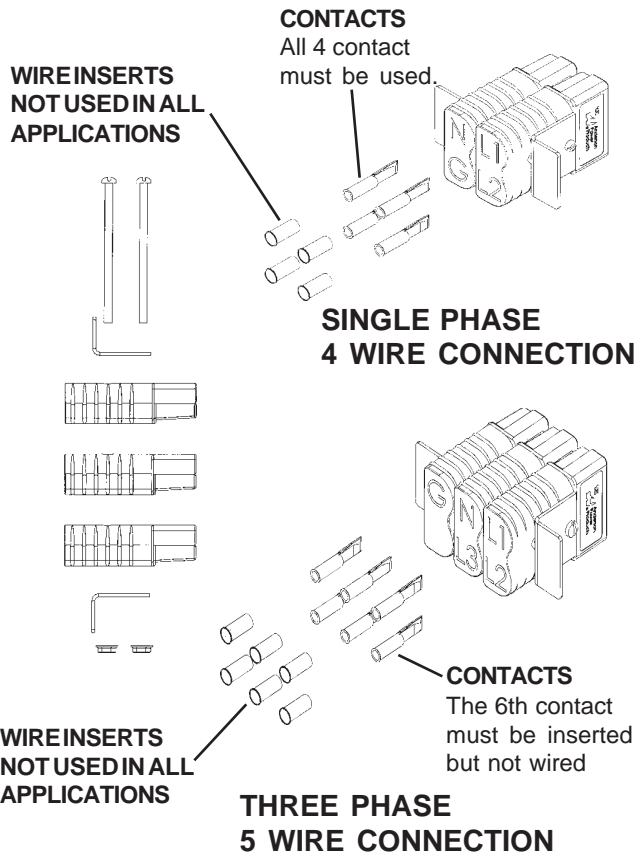

Each wire should be stripped back 7/8 of an inch and inserted into one of the contacts in the plug kit. You will then either need to solder them together using a good grade of resin core solder or they can be crimped with an appropriate compression crimper or both.

Approved Crimping tools are:

1. Anderson Power Products
2. ETC Model HHS hydraulic crimper
3. ITT Blackburn NO. 1640
4. T&B (Thomas & Betts) #TBM5

To complete the assembly of the disconnect plug refer to the instruction sheet in the plug kit.

WARNING: Electrical Shock

DURING THE NEXT STEP, THE LOAD DISCONNECT PLUG SHOULD NOT BE PLUGGED INTO ITS RECEPTACLE. ALSO, MAKE SURE THAT THE EQUIPMENT TO WHICH THE PLUG LEADS (CABLES) ARE BEING CONNECTED IS NOT ENERGIZED (LIVE).

Strip the insulation off the free end of each of the plug leads (cables), and connect them to the load transfer switch (or directly to the load).

Installation

FOUNDATION MOUNTING

Mount the generator on a foundation if it is to be used as a permanent or standby power source (see Figure 2). See

“TRAILER MOUNTING” if generator will be used as a portable power source (see Figure 3). When planning a foundation consider the following points:

Figure 2

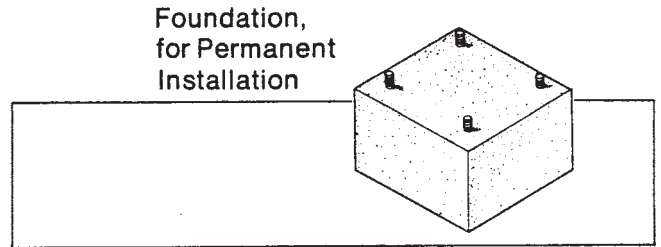

- A. The foundation location should enable aligning the drive shaft (tumbling bar) in a straight or nearly straight line between the power take-off and the generator input shaft. Misalignment must be less than 15 degrees during generator operation, even though the mechanical design of the tumbling bar would allow greater misalignment.
- B. The foundation must be solid enough to absorb generator starting and reflected load torque during operation.
- C. The foundation surface should be flat.
- D. Space is required around the generator for mounting switching devices, making connections, and for servicing.
- E. All four generator mounting pads must rest firmly on the foundation. Install shims if necessary to even out the foundation under the mounting pads then bolt the generator firmly in place.

TRAILER MOUNTING

Mount the generator on a trailer if you plan to use it as a portable power source. See Figure 3. When selecting or building a trailer to mount the generator, consider the following points:

- A. The trailer construction must be strong enough to support the generator.
- B. The design of the trailer must enable the trailer to remain stable during operation, and to resist tipping caused by generator starting and reflected load torque.

Trailer, for Portable Operation

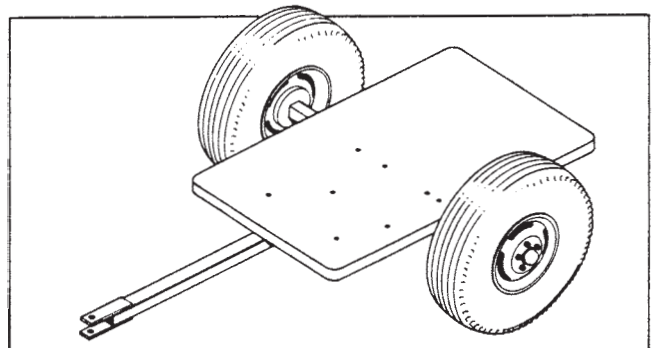

Figure 3

WARNING: Personal Injury & Equipment Damage
 TRAILER MAY TIP OVER AND CAUSE INJURIES IF
 WHEELS ARE NOT SPACED FAR ENOUGH APART.

C. The trailer height and mounting position of the generator on the trailer should enable aligning the drive shaft (tumbling bar) in a straight or nearly straight line between the power take-off and generator input shafts. Misalignment must be less than 15 degrees during generator operation, even though the mechanical design of the tumbling bar would allow greater misalignment.

D. The generator mounting area of the trailer bed should be flat. All four generator mounting pads must rest firmly on the trailer bed. Install shims if necessary to even out the bed under the mounting pads, then bolt the generator firmly in place.

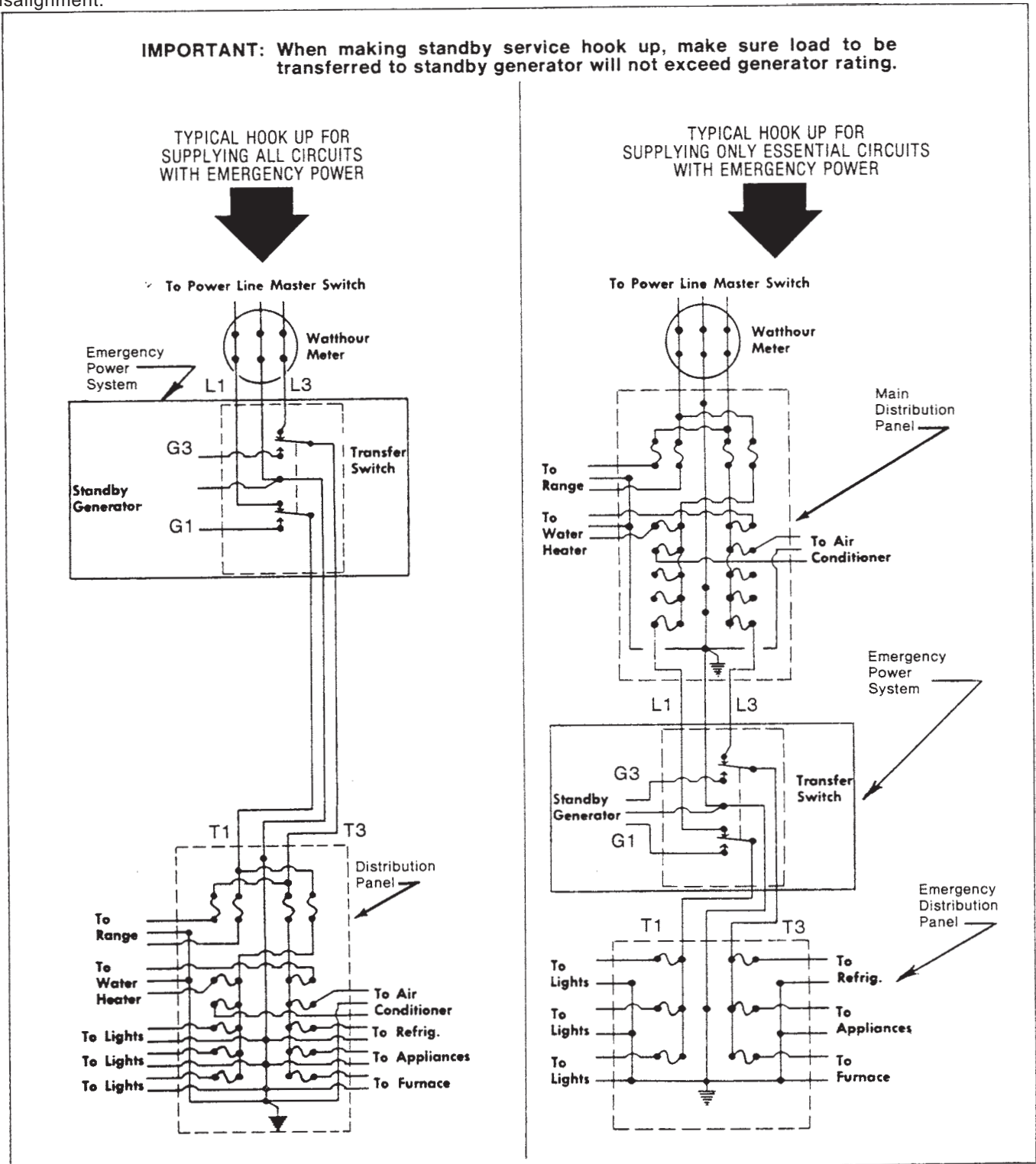

Figure 5

Typical Connection Methods for Generator Power Service

ELECTRICAL CONNECTIONS

CAUTION:

Only qualified electricians should install electrical wiring. Wiring must conform to all applicable national, state, and local codes. (Reference: National Fire Protection Association Manual No. 70, National Electrical Code.)

DANGER: PERSONAL INJURY

IF THE GENERATOR IS TO BE USED AS A STANDBY POWER SOURCE, A SPECIAL DISCONNECT SWITCH MUST BE INSTALLED TO SEPARATE THE GENERATOR AND THE COMMERCIAL POWER LINES. THE DISCONNECT MUST ISOLATE THE GENERATOR FROM THE COMMERCIAL POWER LINES AND THE LOAD WHEN THE GENERATOR IS ON STANDBY, AND MUST ISOLATE THE COMMERCIAL POWER LINES FROM THE LOAD AND THE GENERATOR WHEN THE GENERATOR IS SUPPLYING POWER. SEE FIGURE 5.

OPERATION

OUTPUT POWER AVAILABLE AND LOAD DETERMINATION

Before using the generator, read and understand the following information.

Generator output current (amperage) is internally limited by three circuit breakers. If too much demand is placed on a generator output (if you try to drive too many motors with it, for example), one of the circuit breakers will trip, cutting off the output in order to protect the generator.

A 20 amp push-to-reset circuit breaker protects the 120V duplex receptacle output circuit. 20 amps is the total limit for both outputs of the duplex receptacle.

A 50 amp two pole switch type circuit breaker protects the 240V receptacle output circuit.

A large two pole (three pole for three phase) switch type main circuit breaker protects the generator windings and output circuits, including the load disconnect receptacle outputs. (The load disconnect receptacle is the large gray receptacle on the generator output panel.)

To aid in determining how much load can be applied to the generator, and how it should be distributed among the generator output receptacles, the following formulas may be useful. Get load voltage, current, and wattage from the nameplates on the equipment in the load.

$$\begin{aligned} (\text{Load Current, in amps}) \times (\text{Load Voltage}) &= (\text{Load Wattage}) \\ \text{AMPS} \times \text{VOLTS} &= \text{WATTS} \\ \text{WATT}/1000 &= \text{kW} \end{aligned}$$

$$(\text{Load Current in amps}) = (\text{Load Wattage})/(\text{Load Voltage})$$

Example:

$$250\text{W}, 120\text{V floodlight load} = 250\text{W}/120\text{V} = 2 \text{ amps (approx.)}$$

NOTE:

Electric motors require much more current to start than to run. Commonly, the current rating given on a motor nameplate is the full load (running) current required by the motor, not its starting current, which is a lot higher. Motor starting current requirements vary greatly, by motor size and type. Repulsion-induction type motors are the easiest to start, typically using 1 1/2 to 2 1/2 times as much current to start as to run; capacitor type motors usually require 2 to 4 times as much current to start as to run; split-phase type motors are the hardest to start, normally using 5 to 7 times as much current to start as to run.

MOTOR LOAD Motor Horsepower	SINGLEPHASE		THREEPHASE	
	Amps 115V (Running Amps)	Amps 230V (Running Amps)	Amps 208 (Running Amps)	Amps 240 (Running Amps)
1/4	5.8	2.9		
1/3	7.2	3.6		
1/2	9.8	4.9	2.3	2.0
3/4	13.8	6.9	3.2	2.8
1	16	8	4.15	3.6
1-1/2	20	10	6.0	5.2
2	24	12	7.8	6.8
3	34	17	11	9.6
5	56	28	17.5	15.2
7-1/2	80	40	25	22
10	100	50	32	28
20			62	54
40			120	104

Compiled from N.E.C. Manual.

To use the full capacity of the generator without tripping its circuit breaker(s), start the motors in the load one at a time, highest starting current motor first, next highest second, etc. Use the preceding table as a source of general information about motor running current requirements. For more specific information, see motor nameplate or motor manufacturer's catalog.

PRE-START CHECKS

WARNING: Personal Injury

When working on or around these generators, do not wear loose fitting clothing or any articles that may get caught in moving parts.

1. Visually inspect the generator. Check for:

- a. Correct mounting
- b. Physical damage
- c. Debris in cooling vents and screens (could cause generator to overheat).

IMPORTANT: The manufacturer recommends that, if the generator has been stored for any length of time, before using it, the operator remove the control box cover and cooling fan screen, then inspect the generator for rodent nests or other objects that could cause generator binding and/or overheating. See "Cleaning" portion of Maintenance section.

2. Check gear case oil level. (See Figure 6.) Case should be filled with oil to plug marked "OIL LEVEL." Fill or remove oil as required.

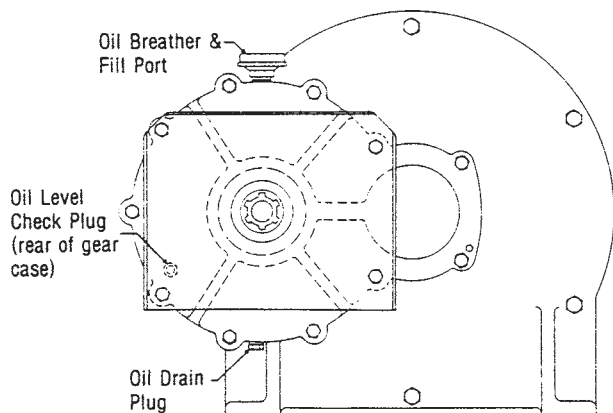

Figure 6

NOTE: EITHER TOO LITTLE OR TOO MUCH OIL CAN HARM THE EQUIPMENT.

See "Lubrication" portion of Maintenance for oil specifications.

3. Make sure the drive shaft (tumbling bar) is assembled with its universal joint knuckles "synchronized," as illustrated in Figure 7. If knuckles are not synchronized, the bar will chatter when rotating, which will cause the generator output voltage to flicker.

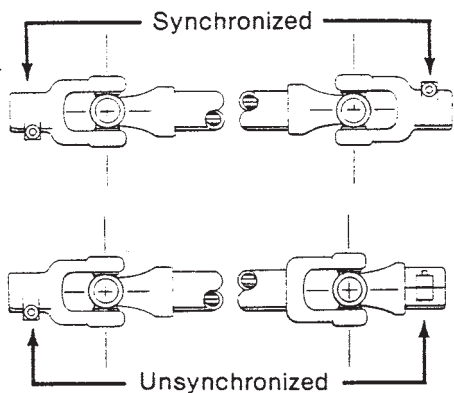

Figure 7

DANGER: Personal Injury
POWER TAKE-OFF MUST BE DISENGAGED AT THIS TIME.

4. Couple the tractor to the generator with the drive shaft (tumbling bar). Couple the tumbling bar to the generator input shaft first, then to the power take-off shaft. Check alignment, tractor, power take-off shaft (tumbling bar), and generator input shaft should form a straight (or nearly straight) line, with less than 15° misalignment between the shafts. Misalignment will cause generator output voltage to flicker.

CAUTION:

Make sure that all tumbling bar lock pins are engaged and that all safety shields are in place before operating the PTO generator.

5. Make sure no binding exists in generator or gear box. If binding is found, locate the cause and correct it before proceeding.

6. Make sure that the electrical loads to be driven by the generator will not draw more current than the ratings of the generator receptacle or cord set which will supply the current.

7. Check all electrical connections in the system to be energized by the generator. Make sure the connections are correct and are tight.

8. Make sure all loads are turned off. Do not start the generator under load.

GENERATOR STARTING PROCEDURE

1. Set the manual transfer to mid or normal (up) position.

2. With the power take-off drive disengaged, start the engine which will drive the generator. Run the engine long enough to warm it up before proceeding, so that it will run smoothly and achieve full power under generator load.

3. With engine idling, engage the power take-off drive.

4. Watch the voltmeter on the generator and slowly increase engine speed until the output reaches approximately 240 to 245 volts (208 to 212 for 208 volt generator), in green portion of voltmeter scale.

5. Plug load cord set into receptacle. Place transfer switch in the emergency position.

6. Place the load circuit breaker in the "on" position. If the breaker trips, move manual transfer switch to "off" or normal position. Check for short circuit or grounded connection in the load cable to the double throw switch and repair. A breaker that trips from overload or short circuit must be reset by moving to "off" before reclosing.

7. With engine and generator running smoothly, switch on the electrical load while watching the voltmeter. Readjust engine throttle to keep generator output under load at 240V (208 V if applicable) in green portion of voltmeter scale. If engine is equipped with speed governor, it may automatically readjust the throttle as the load changes and keep the generator output at the proper level. However, some governors are not sensitive enough to maintain proper output under changing load, and in such cases the throttle will have to be manually readjusted.

NOTE: Equipment Damage

If the load includes motors turn them on one at a time, highest starting current motor first, next highest second, etc.

8. The return of normal power will be indicated by the

lamp on the front of transfer switch; (applicable only when the transfer switch is equipped with indicating lamps or your electrician has installed them). After sufficient time to assure that power restoration isn't temporary, return the transfer switch to normal power (10 - 20 minutes).

9. Place the generator circuit breaker in "off" position. Do not remove plug before opening the breaker.

10. Slowly reduce power take-off speed to a minimum and disengage the power take-off. Some tractors have a brake on the power take-off that stops the shaft instantly. Stopping the alternator rotor instantly from rated speed may result in a broken shaft or other drive line failures.

WARNING: Personal Injury

Never try to manually stop the generator. Always let it coast until it stops.

11. Shut off the engine.

12. Disconnect drive shaft (tumbling bar) power take-off end first, then generator end.

13. Exercise PTO generator for one hour under load at least twice a year.

STORAGE & MAINTENANCE

If the generator is mounted on an off-highway trailer, such as the Winco trailer, it should be stored in a garage, barn or machine shed in a dry and clean location. The generator should be covered with a tarpaulin to prevent the entrance of dust, chaff, and/or moisture.

MAINTENANCE REQUIREMENTS

LUBRICATION

1. Check the generator gear case oil level before each use of the generator. See Figure 4. Maintain the oil level at oil level plug height. The generator is shipped with lubricant in the gear case. Specifications for gear case lubricant are: API Service: GL-5 EP Rated, Grade: SAE 85W-90-140, Amount: 1 pint. The following kinds of oil are recommended for use in the generator gear case:

- Mobil SAE 85W90-140 API Service GL-5
- Sunoco/DX XL80W90-140
- Kendal Three Star 85W-140
- Amoco 85W140 or equivalent

CAUTION: Equipment Damage

Do not overfill generator gear case. Overfilling causes overheating and oil seal failure.

Change the oil every six months or at least once a year. Change it more often if you use the generator in bad weather. Use the following procedure to change generator gear case oil

- a. Remove gear case breather. Soak breather in cleaning solvent, then allow it to dry.
- b. Remove oil level check plug.
- c. Remove the oil drain plug, drain the oil into a clean oil resistant container, 1 quart or larger. Check the oil for metal. Fine metal dust in the oil does not indicate trouble, but metal chips do. Dismantle the gear case and look for damaged gears if you find metal chips in the oil.
- d. Replace the oil drain plug. Refill the gear case through the breather port with new oil of the recommended type. Fill the case up to oil level check plug height. (It will take about 1 pint.)

2. The generator bearings are factory lubricated and sealed, and require no further lubrication.
3. The splined generator input shaft should be cleaned and lubricated with a thin film of grease before and after each use of the generator.
4. The drive shaft (tumbling bar) requires greasing. Keep the universal joints in the coupling shaft free from grease and dirt buildup.

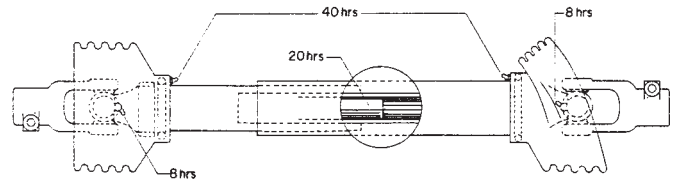

NOTE: Do not over lubricate the universal joints.

CLEANING

1. Inspect for loose or broken wiring connections. Make sure that wiring connections are not loose at the generator end, circuit breakers, and receptacles.
2. Do not allow dirt or chaff to collect in the interior of the generator or the ventilation openings. Inspect for indication of the entrance of mice or insects into the generator. The inlet and outlet openings are louvered, but possible damage to the louvers could occur. Mice can destroy the generator winding.

WARNING: Equipment Damage

DO NOT CLEAN THE GENERATOR WHILE IT IS RUNNING.

CAUTION: Equipment Damage

Most electrical equipment in North America operates satisfactorily at frequencies between 59 and 61 Hz (cycles per second). Operating the generator at frequencies outside that range may cause damage to the generator and/or to electrical equipment driven by the generator.

TROUBLE SHOOTING TABLE

SYMPTOM	CAUSE(S)	CORRECTIVE ACTION
No output voltage.	1. Circuit breaker open.	1. Reset circuit breakers, replace if defective.
	2. Defective voltmeter.	2. Check output with another meter, replace meter if defective.
	3. Short circuit in the load.	3. Disconnect the load. Check voltage at receptacle cord set. Check motors, appliances and load leads for short circuit. Repair short.
	4. Defective receptacles.	4. Remove panel cover and check for voltage to the receptacles. Replace defective receptacles.
	5. Loose (or broken) wires or connections in control box.	5. Remove panel cover and check all wiring and connections. Tighten and/or repair where necessary.
	6. Defective rectifier.	6. Test rectifier. Replace if defective.
	7. Dirty slip rings.	7. Clean and polish. Use 00 sandpaper or crocus cloth, never use emery paper.
	8. Brushes binding in holders.	8. Check brushes for swelling; replace defective brushes; clean brush holders.
	9. Shorted or open rotor.	9. Measure rotor resistance. Replace rotor if open or shorted.
	10. Shorted or open stator.	10. Measure between leads for open or short. Replace stator if defective.
	11. Open transformer.	11. Connect or tighten primary and secondary leads. Check secondary for open circuit. Replace transformer if defective.
	12. Rotating field polarity incorrect.	12. Check by interchanging F (—) and F (+) leads at the brushes. Inner slip ring is positive F (+) and must be connected to the (+) terminal of the rectifier. Flash the field with 12 volts DC.
Low voltage.	1. Engine speed too slow.	1. Check engine speed. Increase RPM if necessary.
	2. Generator overloaded.	2. Reduce load if it is higher than the rated capacity of the generator. (See generator nameplate).
	3. Inadequate engine horsepower.	3. Generator requires 2 HP/1000 watts output. Obtain larger engine if necessary.
	4. Incorrect field excitation. (No-load output low.)	4. Check for worn brushes and weak or broken brush springs; replace as required. Check input AC voltage to rectifier. Check rectifier output DC voltage to positive DC brush. If no DC voltage is present at the brush, replace the rectifier. Check for dirty slip rings. Clean them if they are dirty.
	5. Connection of current transformer secondary leads not correct.	5. Have qualified service technician recheck and correct the connections.

SYMPTOM	CAUSE(S)	CORRECTIVE ACTION
High voltage.	<ol style="list-style-type: none"> 1. Engine speed too fast. 2. Connection of current transformer secondary leads not correct. 	<ol style="list-style-type: none"> 1. Check engine speed for correct input RPM. 2. Have qualified service technician recheck the connections.
Output voltage flickering or fluctuation.	<ol style="list-style-type: none"> 1. Tumbling bar (coupling shaft) misalignment. 2. Engine speed not constant. 3. Loose connection in field circuit. 4. Tumbling bar U-joints not synchronized. 	<ol style="list-style-type: none"> 1. Reduce tumbling bar misalignment to less than 15 degrees. 2. Engine governor may be worn or improperly adjusted. Set or repair defective governor. 3. Check and tighten connections. 4. Reassemble tumbling bar; see Figure 7.
Excessive vibration.	<ol style="list-style-type: none"> 1. Power take-off misalignment excessive. 2. Loose mounting nuts and bolts or hold-down studs. 3. Universal joints in coupling shaft worn or dry. 4. Defective bearings. 	<ol style="list-style-type: none"> 1. Correct misalignment. It should be less than 15 degrees. 2. Tighten mounting nuts and bolts; repair hold-down stud mountings. 3. Repair or replace defective parts. 4. Check for possible causes. Replace defective bearings.
Generator overheating.	<ol style="list-style-type: none"> 1. Poor ventilation. 2. Generator overloaded. 3. Shorted turns in field or stator windings. 	<ol style="list-style-type: none"> 1. Clean ventilation and cooling fan screens. 2. Reduce load, then check voltage and current. 3. Replace defective components.
Oil leak.	<ol style="list-style-type: none"> 1. Loose plug in gear case. 2. Defective seal, gasket, or plug in gear case. 	<ol style="list-style-type: none"> 1. Tighten plug. 2. Replace seal(s), gaskets or plugs. Maintain correct oil level.

WINCO PTO GENERATORS

36 MONTH LIMITED WARRANTY

WINCO, Inc., warrants for thirty-six months from date of shipment, that it will repair or replace at its option, for the original user, the whole or any part of the product found upon examination, by WINCO at its factory at 225 South Cordova Avenue, Le Center, Minnesota, or by any factory-authorized service station, to be defective in material or workmanship under normal standby use (average less than 50 hours per month) and service.

For warranty service, return the product within 36 months from the date of purchase, transportation charges prepaid, to your nearest factory-authorized service station or the WINCO factory.

There is no other express warranty. To the extent permitted by law, any and all warranties, including those of merchantability and fitness for a particular purpose, are limited to 36 months from date of shipment, and liability for incidental or consequential damages or expenses is excluded. Some states do not allow limitations on the duration of an implied warranty, and some states do not allow the exclusion or limitation of incidental or consequential damages, so that above limitation or exclusion may not apply to you. This warranty gives you specific legal rights; you may have other rights which vary from state to state.

This warranty is limited to bench labor and parts only, no allowance will be made for travel time, or removal and reinstallation of the PTO unit.

WINCO does not warrant drive lines, trailer tires, receptacles, or certain other component parts of the product installed by others, since such items are warranted by their manufacturers.

WINCO does not warrant modifications or alterations which were not made or authorized by the WINCO factory and which affect the stability or reliability of the product.

WINCO does not warrant products which have been exposed to misuse and/or negligence or have been involved in an accident.

WINCO does not warrant products which have been installed in such a manner as not to protect them from the adverse environmental conditions (water, mud, insects, etc.) or have not been kept clean.

WINCO reserves the right to change or improve its products without incurring any obligations to make such changes or improvements on products purchased previously.