

WINCO INC *Tractor Drive PTO Generators*

OWNERS MANUAL

INSTALLATION AND OPERATION INSTRUCTIONS

**W85PTOS
W100PTO
W105PTOT
W135PTOS
W145PTOT
W150PTOS
W165PTOT**



SAFETY FIRST

READ THIS MANUAL BEFORE OPERATING YOUR GENERATOR.

Read and understand all instructions in this manual before starting and operating the generator set.

USING THIS MANUAL

Congratulations on your choice of a Winco generator set. You have selected a high-quality, precision-engineered generator set designed and tested to give you years of satisfactory standby service.

To get the best performance from your new generator set, it is important that you carefully read and follow the operating instructions in this manual.

Should you experience a problem please follow the "Things To Check" near the end of this manual. The warranty listed in this manual describes what you can expect from WINCO should you need service assistance in the future.

TABLE OF CONTENTS

INTRODUCTION	i
GUIDE TO PRODUCT SAFETY	1
DESCRIPTION	2
PREPARING THE UNIT	2
Unpacking the unit	2
Specifications	2
Assembly	2
INSTALLATION	
Foundation Mounting	3
Trailer Mounting	3
ELECTRICAL CONNECTIONS	4
OPERATION	5
Pre-Start Checks	5
Starting Procedure	6
Stopping	6
MAINTENANCE	7
Lubrication	7
Cleaning	8
Storage	8
Trouble Shooting Table	8
GENERATOR CONNECTIONS	
120/240 Volt Single Phase	10
120/240 Volt Three Phase	10
120/208 Volt Three Phase	11
277/480 Volt Three Phase	11
GENERATOR RECEPTACLE PANELS	12
Convenience Receptacle Wiring	13
36 MONTH WARRANTY	14

PROPER USE AND INSTALLATION

You must be sure your new generator set is:

- * Properly serviced before operating
- * Operated in a well ventilated area
- * Exhaust gases are dispersed safely
- * Wired by a qualified electrician
- * Operated only for its designed purposes
- * Used only by operators who understand its operation
- * Properly maintained

COPY YOUR MODEL AND SERIAL NUMBER HERE

No other WINCO generator has the same serial number as yours. It is important that you record the number and other vital information here, if you should ever need to contact us on this unit it will help us to respond to your needs faster.

MODEL _____

SERIAL NUMBER _____

PURCHASE DATE _____

DEALER _____

SAFETY INFORMATION

This generator set has been designed and manufactured to allow safe, reliable performance. Poor maintenance, improper or careless use can result in potential deadly hazards; from electrical shock, exhaust gas asphyxiation, or fire. Please read all safety instructions carefully before installation or use. Keep these instructions handy for future reference. Take special note and follow all warnings on the unit labels and in the manuals.

ANSI SAFETY DEFINITIONS

DANGER:

DANGER indicates an imminently hazardous situation which, if not avoided, will result in death or serious injury. This signal word is to be limited to the most extreme situations.

WARNING:

WARNING indicates a potentially hazardous situation which, if not avoided, could result in death or serious injury.

CAUTION:

CAUTION indicates a potentially hazardous situation which, if not avoided, may result in minor or moderate injury. It may also be used to alert against unsafe practices.

NOTE:

CAUTION is also used on the unit labels and in this manual to indicate a situation that could result in serious damage or destruction of the equipment and possible personal injury.

1. **ELECTRIC SHOCK-** The output voltage present in this equipment can cause a fatal electric shock. This equipment must be operated by a responsible person.
 - a. Do not allow anyone to operate the generator without proper instruction.
 - b. Guard against electric shock.
 - c. Avoid contact with live terminals or receptacles.
 - d. Use extreme care if operating this unit in rain or snow.
 - e. Use only three-prong grounded plugs and extension cords.
 - f. Be sure the unit is properly grounded to an external ground rod driven into the earth.
 - g. Do not make or break electrical connection under load.
2. **FIRE HAZARD-** Gasoline, diesel and other fuels always present a hazard of possible explosion and/or fire.
 - a. Keep a fire extinguisher nearby and know its proper use. Fire extinguishers rated ABC by NFPA are appropriate.

3. **DEADLY EXHAUST GAS** - Exhaust fumes from any engine contain carbon monoxide, an invisible, odorless and deadly gas that must be mixed with fresh air.

- a. Operate only in well ventilated areas.
- b. Never operate indoors.

4. **NOISE HAZARD** - Excessive noise is not only tiring, but continual exposure can lead to loss of hearing.

- a. Use hearing protection equipment when working around this equipment for long periods of time.
- b. Keep your neighbors in mind when permanently installing this equipment.

5. **CLEANLINESS-** Keep the generator and surrounding area clean.

- a. Remove all grease, ice, snow or materials that create slippery conditions around the unit.
- b. Remove any rags or other material that could create potential fire hazards.

6. **SERVICING EQUIPMENT-** All service, including the installation or replacement of service parts, should be performed only by a qualified technician.

- a. Use only factory approved repair parts.
- b. Do not work on this equipment when fatigued.
- c. Use extreme caution when working on electrical components. High output voltages from this equipment can cause serious injury or death.
- d. Always avoid hot mufflers, exhaust manifolds, and engine parts. They all can cause severe burns instantly.

7. **INSTALLATION-** Installing a PTO generator is not a “do-it-yourself” project. Consult a qualified, licensed electrician or contractor. The installation must comply with all national, state, and local codes.

- a. Never operate the PTO drive generator without having it properly mounted to a concrete base or approved trailer.
- b. Never connect the PTO generator to an existing electrical system without installing an isolation transfer switch.
- c. Always insure the drive shaft is straight and level before operating the generator.

8. **OPERATION** - PTO drive shafts (Tumbling Bars) have many inherent dangers, extreme caution must be exercised when using them.

- a. **NEVER** allow children around a drive shaft when it is in operation.
- b. Keep all safety guards and shields in place and securely tightened.
- c. Never operate a drive shaft that has been damaged or had the safety shield removed.
- d. Never step over a drive shaft while it is running.
- e. Never wear a necktie, loose articles of clothing, or anything else that can be caught in moving parts when operating the PTO.
- f. Never try to stop a turning drive shaft with your hand or your foot.

DESCRIPTION

The WINCO PTO drive generator will provide, depending on the unit purchased, 120/240V single phase, 120/240V three phase, 120/208 three phase or 277/480 three phase 60Hz electrical service when direct-driven. Tractor or vehicle power take-off shafts, can be used for driving these generators.

NOTE: The prime mover which drives the generator must be capable of delivering approximately 2 HP per 1000 watts output from the generator. Observe input RPM specifications.

The generator may be foundation mounted for use as standby power source, or trailer mounted, and used as portable electrical power sources for areas where commercial power is not readily available, such as out buildings.

This generator includes an Automatic Voltage Regulator (AVR) which maintains a constant voltage output and a Frequency meter to insure the unit is producing 60 Hz power. All the models (except the 480 volt units) have a control panel with two output power receptacles, and overload protection circuit breakers, and most models are equipped with a full load disconnect plug (not applicable on the 135, 145 and 150 kW models) To reduce maintenance problems, the coupling between the generator input shaft and rotor consists of precision helical gearing. The input shaft is 1-3/4 in diameter 20 spline .

The factory thoroughly tests each of these generators before shipment. All are continuous duty rated.

IMPORTANT: THE MANUFACTURER STRONGLY RECOMMENDS RUNNING THE GENERATOR UNDER LOAD AT LEAST ONCE A MONTH IN ORDER TO EVAPORATE ANY ACCUMULATED MOISTURE CONDENSATION

UNPACKING

CAUTION: Equipment Damage

DO NOT invert generator during unpacking. The Gearcase contains oil which will leak out if inverted during unpacking.

Unpack the generator as follows:

1. Remove the crate.
2. Examine the unit for damage.
3. Find the small subpack carton packed in the large carton. Be careful not to throw away the subpack carton with the large carton.
4. Open the subpack carton and make sure it contains:
 - a. Generator instruction manual
 - b. Load disconnect plug (disassembled, in bag)
5. Remove the four bolts which hold down the generator feet to the pallet.
6. Lift the generator from the pallet by means of the lifting eye on the top of the generator.
7. Inspect the generator carefully for freight loss or damage. If loss or damage is noted at time of delivery, require that the

person making the delivery make note of the loss or damage on the freight bill, or sign the consignee's memo of the loss or damage. Contact the carrier for claim procedures.

When loss or damage is noted after delivery, segregate the damaged material, and contact the carrier for claim procedures.

“Concealed damage” means damage to the contents of a package which is not evident when the package is delivered by the carrier, but which is discovered later. The carrier or carriers are responsible for merchandise lost or damaged in transit. The title to the goods rests with the consignee when the goods are shipped FOB factory, and only the consignee can legally file claims.

Specifications

MODEL	VOLTAGE	PHASE	P/F	AMPERAGE
W85PTOS	120/240	Single	1.0	354
W100PTOS	120/240	Single	1.0	416
W105PTOT-4	120/208	Three	0.8	365
W105PTOT-17	120/240	Three	0.8	316
W105PTOT-18	277/480	Three	0.8	158
W135PTOS	120/240	Single	1.0	560
W145PTOT-4	120/208	Three	0.8	504
W145PTOT-17	120/240	Three	0.8	436
W165PTOT-18	277/480	Three	0.8	198
W150PTOS	120/240	Single	1.0	625

Assembly

The only assembly work required after unpacking the generator is to assemble the load disconnect plug, which is contained in a bag in the subpack carton packed in the generator crate. **NOTE - The 135kW, 145kW and 150kW units do not ship with disconnect plugs and must be hard wired to the main line circuit breaker.**

The bag contains an instruction sheet, 2 plug bodies, four contacts, a handle and the hardware to assembly the disconnect plug. You will need to purchase the appropriate length of fine stranded copper wire for your application in order to complete the assembly of the disconnect plug.

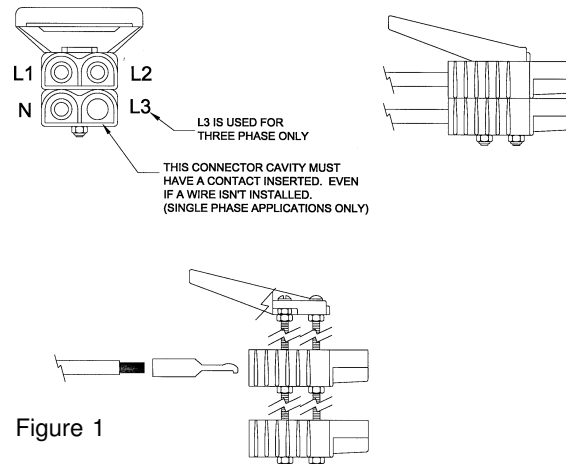

Figure 1

The following wire sizes are recommended for each unit.

Generator Model	Size AWG	Insulation	
W85PTOS	4/0	Neoprene/THHN	
W100PTOS	4/0	Neoprene/THHN	
W105PTOT	4/0	Neoprene/THHN	
W135PTOS	350MCM	THHN	NO Plug Provided
W145PTOT	4/0	THHN	NO Plug Provided
W150PTOS	500MCM	THHN	NO Plug Provided
W165PTOT	1/0	THHN	NO Plug Provided

WARNING: Equipment Damage

Never use acid core solder. When soldering insure no excess solder runs down on the contact surface - Solder on the contact surface will not allow the contacts to mate properly causing them to burn up.

Each wire should be stripped back 7/8 of an inch and inserted into one of the contacts in the plug kit. You will then either need to solder them together using a good grade of resin core solder or they can be crimped with an appropriate compression crimper or both.

Approved Crimping tools are:

1. Anderson Power Products
2. ETC Model HHS hydraulic crimper
3. ITT Blackburn NO. 1640
4. T&B (Thomas & Betts) #TBM5

To complete the assembly of the disconnect plug refer to the instruction sheet in the plug kit.

WARNING: Electrical Shock

DURING THE NEXT STEP, THE LOAD DISCONNECT PLUG SHOULD NOT BE PLUGGED INTO ITS RECEPTACLE. ALSO, MAKE SURE THAT THE EQUIPMENT TO WHICH THE PLUG LEADS (CABLES) ARE BEING CONNECTED IS NOT ENERGIZED (LIVE).

8. Strip the insulation off the free end of each of the plug leads (cables), and connect them to the load transfer switch (or directly to the load).

Installation

FOUNDATION MOUNTING

Mount the generator on a foundation if it is to be used as a permanent or standby power source (see Figure 2). See "TRAILER MOUNTING" if generator will be used as a portable power source (see Figure 3). When planning a foundation consider the following points:

Foundation, for Permanent Installation

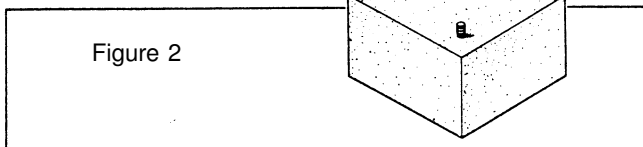

Figure 2

A. The foundation location should enable aligning the drive shaft (tumbling bar) in a straight or nearly straight line between the power take-off and the generator input shaft. Misalignment must be less than 15 degrees during generator operation, even though the mechanical design of the tumbling bar may allow greater misalignment.

B. The foundation must be solid enough to absorb generator starting and reflected load torque during operation.

C. The foundation surface should be flat.

D. Space is required around the generator for mounting switching devices, making connections, and for servicing.

E. All four generator mounting pads must rest firmly on the foundation. Install shims if necessary to even out the foundation under the mounting pads then bolt the generator firmly in place.

TRAILER MOUNTING

Mount the generator on a trailer if you plan to use it as a portable power source. See Figure 3. When selecting or building a trailer to mount the generator, consider the following points:

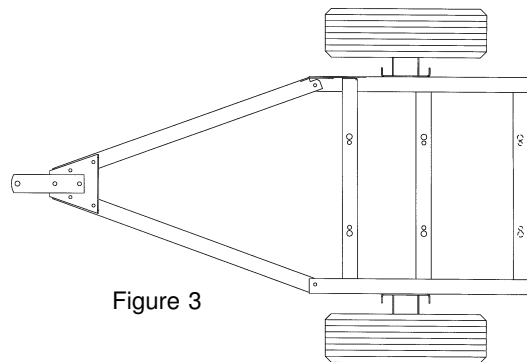

Figure 3

Trailer, for Portable Operation

A. The trailer construction must be strong enough to support the generator.

B. The design of the trailer must enable the trailer to remain stable during operation, and to resist tipping caused by generator starting and reflected load torque.

WARNING: Personal Injury & Equipment Damage

TRAILER MAY TIP OVER AND CAUSE INJURIES IF WHEELS ARE NOT SPACED FAR ENOUGH APART.

C. The trailer height and mounting position of the generator on the trailer should enable aligning the drive shaft (tumbling bar) in a straight or nearly straight line between the power take-off and generator input shafts. Misalignment must be less than 15 degrees during generator operation, even though the mechanical design of the tumbling bar would allow greater misalignment.

D. The generator mounting area of the trailer bed should be flat. All four generator mounting pads must rest firmly on the trailer bed. Install shims if necessary to even out the bed under the mounting pads, then bolt the generator firmly in place.

Wiring must conform to all applicable national, state, and local codes. (Reference: National Fire Protection Association Manual No. 70, National Electrical Code.)

ELECTRICAL CONNECTIONS

CAUTION:

Only qualified electricians should install electrical wiring.

DANGER: PERSONAL INJURY

IF THE GENERATOR IS TO BE USED AS A STANDBY POWER SOURCE, A SPECIAL DISCONNECT SWITCH MUST BE INSTALLED TO SEPARATE THE GENERATOR AND THE COMMERCIAL POWER LINES. THE DISCONNECT MUST ISOLATE THE GENERATOR FROM THE COMMERCIAL POWER LINES AND THE LOAD WHEN

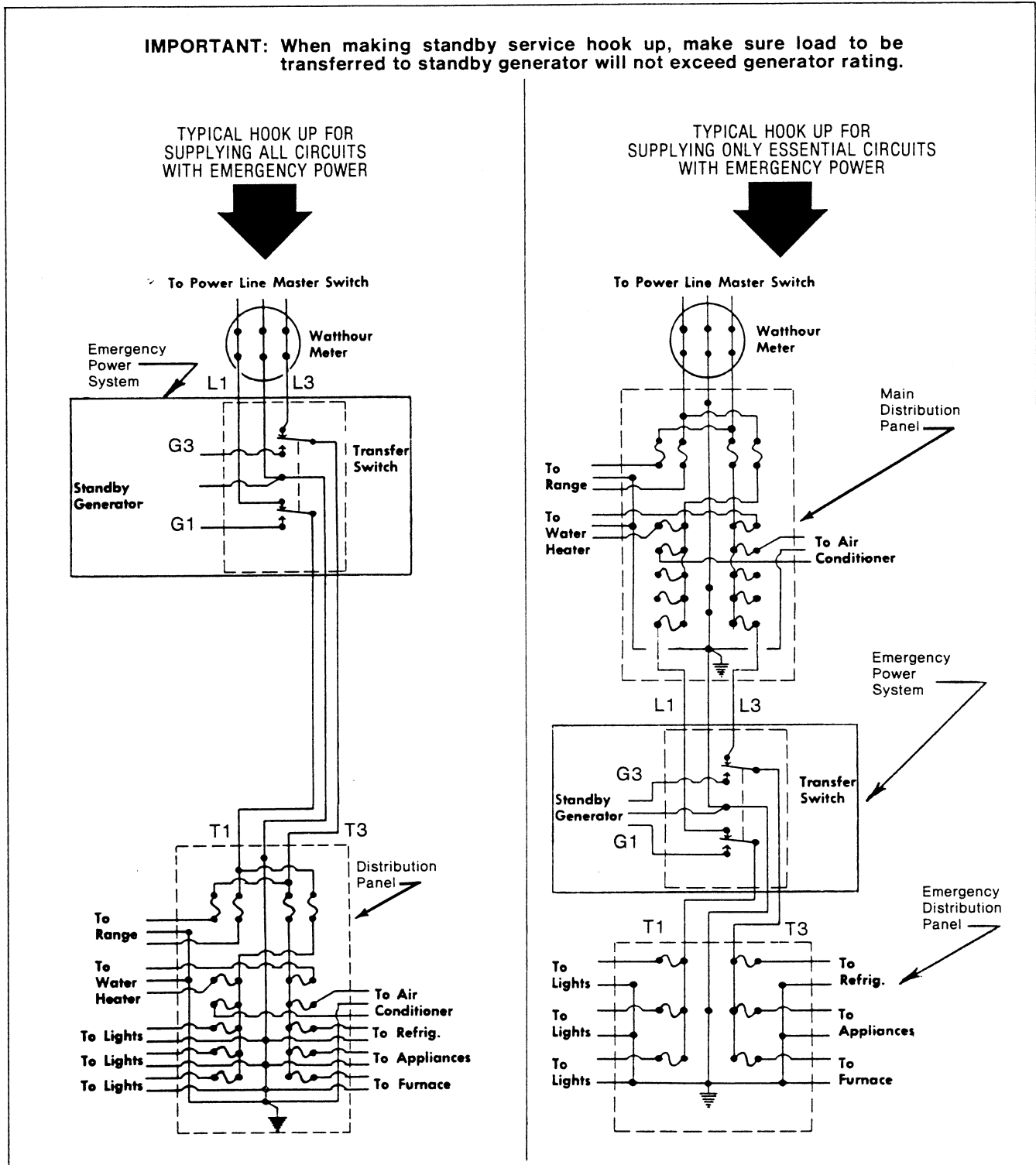

Figure 5

Typical Connection Methods for Generator Power Service

THE GENERATOR IS ON STANDBY, AND MUST ISOLATE THE COMMERCIAL POWER LINES FROM THE LOAD AND THE GENERATOR WHEN THE GENERATOR IS SUPPLYING POWER. SEE FIGURE 5.

Operation

OUTPUT POWER AVAILABLE AND LOAD DETERMINATION

Before using the generator, read and understand the following information.

Generator output current (amperage) is internally limited by three circuit breakers. If too much demand is placed on a generator output (if you try to drive too many motors with it, for example), one of the circuit breakers will trip, cutting off the output in order to protect the generator.

A 15 amp push-to-reset circuit breaker protects the 120V duplex receptacle output circuit. 15 amps is the total limit for both outputs of the duplex receptacle. (Not available on the 480 volt three phase generators.)

A 50 amp two pole switch type circuit breaker protects the 240V receptacle output circuit. (Not available on the 480 volt three phase generators.)

A large two pole (three pole for three phase) switch type main circuit breaker protects the generator windings and output circuits, including the load disconnect receptacle. (On the W135PTOS, W145PTOT and the 150PTOS you will connect your power output leads directly to the mainline circuit breaker.)

To aid in determining how much load can be applied to the generator, and how it should be distributed among the generator output receptacles, the following formulas may be useful. Get load voltage, current, and wattage from the nameplates on the equipment in the load.

$$\begin{aligned} (\text{Load Current, in amps}) \times (\text{Load Voltage}) &= (\text{Load Wattage}) \\ \text{AMPS} \times \text{VOLTS} &= \text{WATTS} \\ \text{WATT} / 1000 &= \text{kW} \end{aligned}$$

$$(\text{Load Current in amps}) = (\text{Load Wattage}) / (\text{Load Voltage})$$

Example:
250W, 120V floodlight load = 250W/120V = 2 amps (parrots.)

NOTE:

Electric motors require much more current to start than to run. Commonly, the current rating given on a motor nameplate is the full load (running) current required by the motor, not its starting current, which is a lot higher. Motor starting current requirements vary greatly, by motor size and type. Repulsion-induction type motors are the easiest to start, typically using 1 1/2 to 2 1/2 times as much current to start as to run; capacitor type motors usually require 2 to 4 times as much current to start as to run; split-phase type motors are the hardest to start, normally using 5 to 7 times as much current to start as to run.

MOTORLOAD Motor Horsepower	SINGLEPHASE		THREEPHASE	
	Amps 115V	Amps 230V (Running Amps)	Amps 208 (Running Amps)	Amps 240 (Running Amps)
1/4	5.8	2.9		
1/3	7.2	3.6		
1/2	9.8	4.9	2.3	2.0
3/4	13.8	6.9	3.2	2.8
1	16	8	4.15	3.6
1-1/2	20	10	6.0	5.2
2	24	12	7.8	6.8
3	34	17	11	9.6
5	56	28	17.5	15.2
7-1/2	80	40	25	22
10	100	50	32	28
20			62	54
40			120	104

Compiled from N.E.C. manual.

To use the full capacity of the generator without tripping its circuit breaker(s), start the motors in the load one at a time, highest starting current motor first, next highest second, etc. Use the preceding table as a source of general information about motor running current requirements. For more specific information, see motor nameplate or motor manufacturer's catalog.

PRE-START CHECKS

WARNING: Personal Injury

When working on or around these generators, do not wear loose fitting clothing or any articles that may get caught in moving parts.

1. Visually inspect the generator. Check for:

- Correct mounting
- Physical damage
- Debris in cooling vents and screens (could cause generator to overheat).

IMPORTANT: The manufacturer recommends that, if the generator has been stored for any length of time, before using it, the operator remove the control box cover and cooling fan screen, then inspect the generator for rodent nests or other objects that could cause generator binding and/or overheating. See "Cleaning" portion of Maintenance section.

2. Check gear case oil level. (See Figure 6.) Case should be filled with oil to plug marked "OIL LEVEL." Fill or remove oil as required.

NOTE: EITHER TOO LITTLE OR TOO MUCH OIL CAN HARM THE EQUIPMENT.

See "Lubrication" portion of Maintenance for oil specifications.

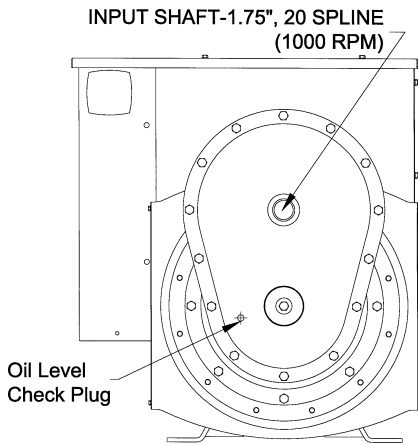

Figure 6

3. Make sure the drive shaft (tumbling bar) is assembled with its universal joint knuckles "synchronized," as illustrated in Figure 7. If knuckles are not synchronized, the bar will chatter when rotating, which will cause the generator output voltage to flicker.

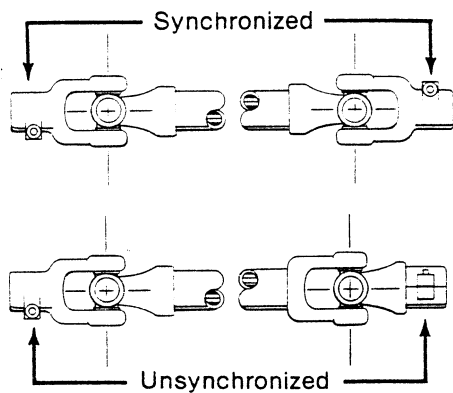

Figure 7

DANGER: Personal Injury

POWER TAKE-OFF MUST BE DISENGAGED AT THIS TIME.

4. Couple the tractor to the generator with the drive shaft (tumbling bar). Couple the tumbling bar to the generator input shaft first, then to the power take-off shaft. Check alignment of tractor, power take-off shaft (tumbling bar), and generator input shaft should form a straight (or nearly straight) line, with less than 15° misalignment between the shafts. Misalignment will stress the drive line and cause generator output voltage to flicker.

CAUTION:

Make sure that all tumbling bar lock pins are engaged and that all safety shields are in place before operating the PTO generator.

5. Make sure no binding exists in generator or gear box. If binding is found, locate the cause and correct it before proceeding.

6. Make sure that the electrical loads to be powered by the generator will not exceed the current ratings of the generator, receptacle, or cord set which will supply the current.

7. Check all electrical connections in the system to be energized by the generator. Make sure the connections are correct and tight and the load disconnect plug (if provided) is fully seated in the receptacle.

8. Make sure all loads are turned off. Do not start the generator under load.

GENERATOR STARTING PROCEDURE

1. With the power take-off drive disengaged, start the engine which will drive the generator. Run the engine long enough to warm it up before proceeding, so that it will run smoothly and achieve full power under generator load.

2. With engine idling, engage the power take-off drive.

3. Watch the frequency meter on the generator and slowly increase engine speed until the frequency reaches approximately 60 Hz. The voltage output of the generator is controlled by an Automatic Voltage Regulator (AVR). Before turning on any load check your voltage output from the generator using a volt/ohm meter. If the voltage is either high or low adjust the voltage level by turning the voltage adjustment screw on the AVR. The AVR is located inside the generator control cabinet. Once the proper voltage level is set the AVR should bring the voltage back to the same level each time the unit is started up. But as a precaution it should be checked each time you use the generator. As quick check you can plug in a troublelight and check for normal brightness.

4. With engine and generator running smoothly, switch on the electrical load while watching the frequency meter.

NOTE: Equipment Damage

If the load includes motors turn them on one at a time, highest starting current motor first, next highest second, etc.

Adjust engine throttle to keep generator output under load at 60 Hz. If the engine is equipped with a governor, it may automatically adjust the throttle as the load changes and keep the generator output at the proper level. However, some governors are not sensitive enough to maintain proper output under changing loads, and in such cases the frequency will have to be monitored closely and manually adjusted.

GENERATOR SHUTDOWN PROCEDURE

1. Switch off electrical load.

2. Reduce speed of engine driving generator to idle.

3. Disengage power take-off drive, and allow generator to coast to a stop.

WARNING: Personal Injury

Never try to manually stop the generator. Always let it coast until it stops.

5. Shut off the engine.
4. Disconnect drive shaft (tumbling bar) power take-off end first, then generator end.

MAINTENANCE

The following chart lists various symptoms of poor generator operation with possible causes for them and the appropriate corrective action. You will need a volt-ohm meter or test light to check some of the causes. For some of the other causes you will need to check generator speed. To check the generator speed you can use the frequency meter on the generator control panel.

CAUTION: Equipment Damage

Most electrical equipment in North America operates satisfactorily at frequencies between 59 and 61 Hz (cycles per second.) Operating the generator at frequencies outside that range may cause damage to the generator and/or to electrical equipment driven by the generator.

GENERAL

Routine preventive maintenance minimizes costly repairs and generator downtime. Before each use, inspect the generator: gear case oil level should be correct, cooling vents and screens should be clear, and generator mounting hardware should be tight. Clean and inspect the generator after storing it for long periods, and after using it in extremely dusty conditions or in severe weather, such as rain or blowing snow.

LUBRICATION

The generator bearings are factory lubricated and sealed, and require no further lubrication.

The splined generator input shaft should be cleaned and lubricated with a thin film of grease before and after each use of the generator.

The drive shaft (tumbling bar) requires greasing. Keep the universal joints in the coupling shaft free from grease and dirt buildup.

NOTE:

Do not over lubricate the universal joints.

See Figure 8 for recommended lubrication schedule for the coupling shaft.

Check the generator gear case oil level before each use of the generator. Maintain the oil level at oil level plug height. (Figure 6 illustrates oil level plug location.) The generator is shipped with lubricant in the gear case. Specifications for gear case lubricant are:

API Service: GL-5
Grade: SAE 85W-90-140
Amount: 1 pint

The following kinds of oil are recommended for use in the generator gear case: Mobil SAE 85W90-140 API Service GL-5, Sunoco/DX XL80W90-140 Kendal Three Star 85W-140, Amoco 85W140 or equivalent.

CAUTION: Equipment Damage

Do not overfill generator gear case. Overfilling causes overheating and oil seal failure.

Change the oil at least once every six months. Change it more often if you use the generator in bad weather. Use the following procedure to change generator gear case oil (see Figure 6):

1. Remove gear case breather. Soak breather in cleaning solvent, then allow it to dry.
2. Remove oil level check plug.
3. Remove the oil drain plug, drain the oil into a clean oil resistant container, 1 quart or larger. Check the oil for metal. Fine metal dust in the oil does not indicate trouble, but metal chips do. Dismantle the gear case and look for damaged gears if you find metal chips in the oil.
4. Replace the oil drain plug. Refill the gear case through the breather port with new oil of the recommended type. Fill the case up to oil level check plug height. (It will take about 1 pint.)

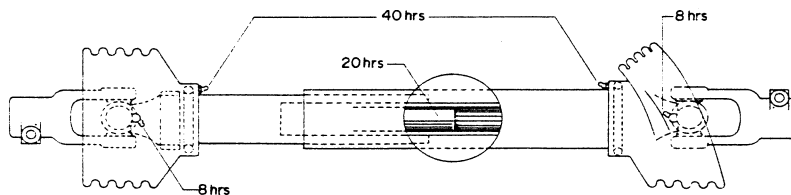

Figure 8

5. Replace the oil level check plug.
6. Replace the breather.

CLEANING & INSPECTING THE GENERATOR

Use a vacuum cleaner or dry low pressure compressed air (regulated at 25-35 PSI) to clean the generator periodically.

WARNING: Equipment Damage

DO NOT CLEAN THE GENERATOR WHILE IT IS RUNNING.

Proceed as follows:

1. Remove ventilated control box cover. Vacuum or blow vents and screen clear of dust or debris. Wash them down with cleaning solvent if necessary.

2. Remove cooling fan shroud. Vacuum or blow dust from screen and fan blades. Wipe them off with cleaning solvent if necessary.

3. Vacuum or blow dust and other debris from inside generator and control box.

4. With panel cover removed, inspect the wiring for correct routing, fraying insulation, and secure connections.

5. Replace panel cover and cooling fan shroud.

GENERATOR STORAGE

Before storing the generator, apply a heavy coat of grease to the splined input shaft. Store the generator in a sheltered area, where it is protected against snow, rain, and excessive dust.

TROUBLE SHOOTING TABLE

SYMPTOM	CAUSE(S)	CORRECTIVE ACTION
No output voltage.	<ol style="list-style-type: none"> 1. Circuit breaker open. 2. Defective frequency meter. 3. Short circuit in the load. 4. Defective receptacles. 5. Loose (or broken) wires or connections in control box. 6. Defective rotating rectifier. 7. Defective AVR 9. Shorted or open rotor. 10. Shorted or open stator. 	<ol style="list-style-type: none"> 1. Reset circuit breakers, replace if defective. 2. Check output with another meter, replace meter if defective. 3. Disconnect the load. Check voltage at receptacle cord set. Check motors, appliances and load leads for short circuit. Repair short. 4. Remove panel cover and check for voltage to the receptacles. Replace defective receptacles. 5. Remove panel cover and check all wiring and connections. Tighten and/or repair where necessary. 6. Test rectifier. Replace if defective. 7. Repair or replace as required 9. Measure rotor resistance. Replace rotor if open or shorted. 10. Measure between leads for open or short. Replace stator if defective.
Low voltage.	<ol style="list-style-type: none"> 1. Engine speed too slow. 2. Generator overloaded. 3. Inadequate engine horsepower. 4. Defective or mis adjusted AVR 	<ol style="list-style-type: none"> 1. Check engine speed. Increase RPM if necessary. 2. Reduce load if it is higher than the rated capacity of the generator. (See generator nameplate). 3. Generator requires 2 HP/1000 watts output. Obtain larger engine if necessary. 4. Repair, adjust or replace as required

SYMPTOM	CAUSE(S)	CORRECTIVE ACTION
High voltage.	1. Defective or misadjusted AVR	1. Adjust, repair or replace as required.
Output voltage flickering or fluctuation.	1. Tumbling bar (coupling shaft) misalignment. 2. Engine speed not constant. 3. Loose connection in field circuit. 4. Tumbling bar U-joints not synchronized.	1. Reduce tumbling bar misalignment to less than 15 degrees. 2. Engine governor may be worn or improperly adjusted. Set or repair defective governor. 3. Check and tighten connections. 4. Reassemble tumbling bar; see Figure 7.
Excessive vibration.	1. Power take-off misalignment excessive. 2. Loose mounting nuts and bolts or hold-down studs. 3. Universal joints in coupling shaft worn or dry. 4. Defective bearings.	1. Correct misalignment. It should be less than 15 degrees. 2. Tighten mounting nuts and bolts; repair hold-down stud mountings. 3. Repair or replace defective parts. 4. Check for possible causes. Replace defective bearings.
Generator overheating.	1. Poor ventilation. 2. Generator overloaded. 3. Shorted turns in field or stator windings.	1. Clean ventilation and cooling fan screens. 2. Reduce load, then check voltage and current. 3. Replace defective components.
Oil leak.	1. Loose plug in gear case. 2. Defective seal, gasket, or plug in gear case.	1. Tighten plug. 2. Replace seal(s), gaskets or plugs. Maintain correct oil level.

TO CONNECTOR OR CUSTOMER CONNECTION

PANEL MOUNTED METER

GENERATOR CONNECTIONS 120/240 VOLT SINGLE PHASE

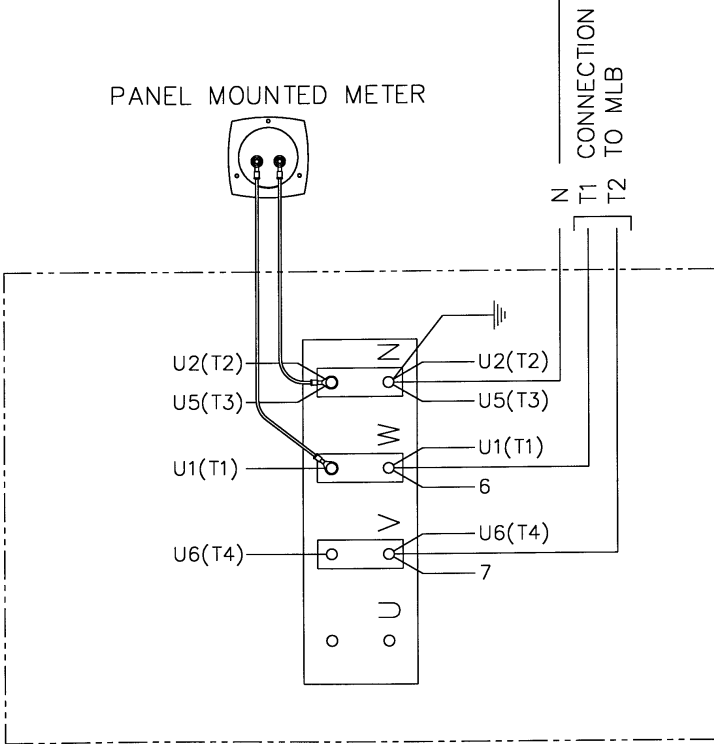

GENERATOR CONNECTIONS 120/240 VOLT THREE PHASE

PANEL MOUNTED METER

TO CONNECTOR OR CUSTOMER CONNECTION

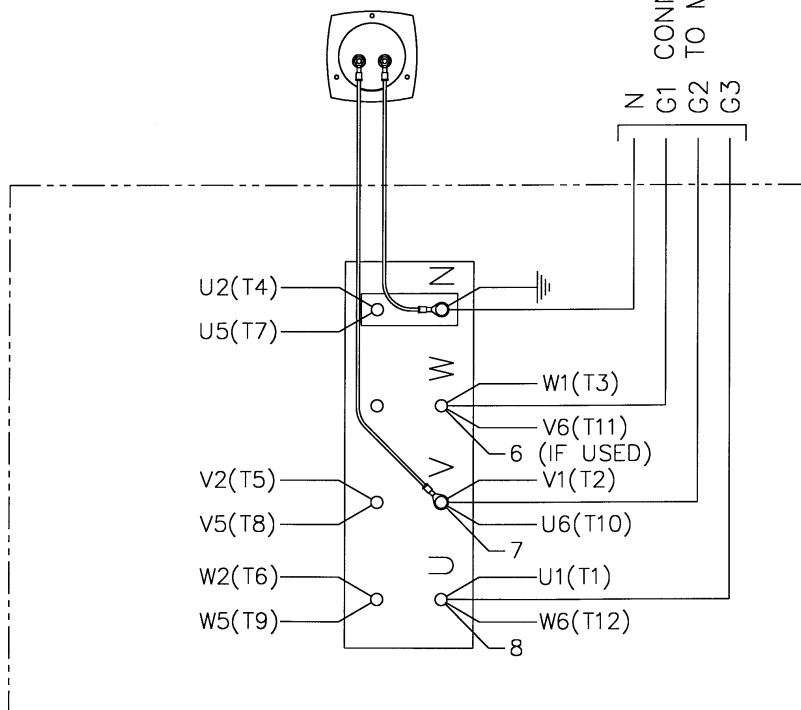

PANEL MOUNTED METER

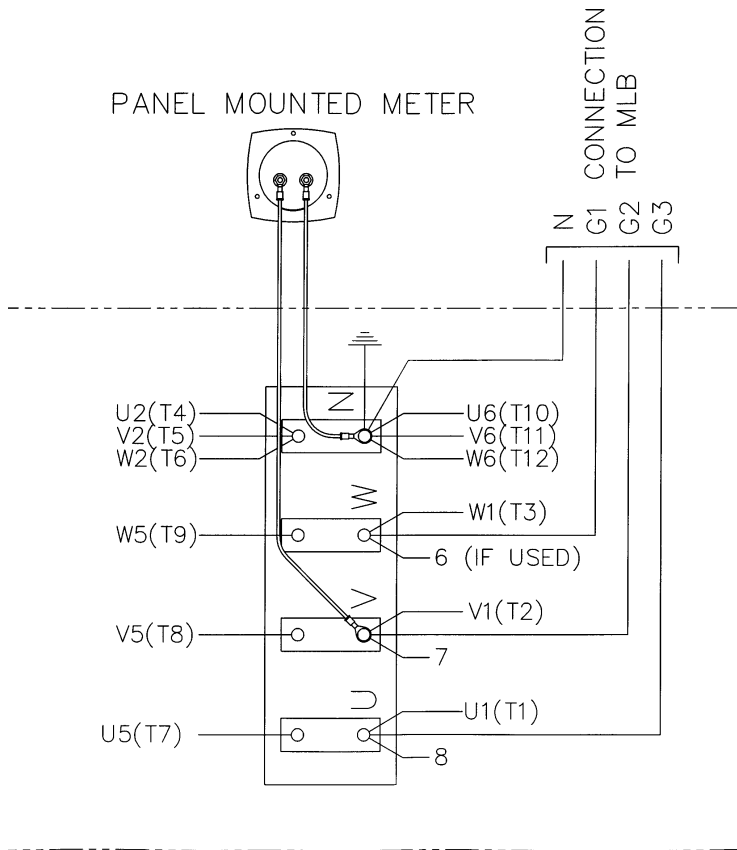

**GENERATOR CONNECTIONS
120/208 VOLT
THREE PHASE**

**GENERATOR CONNECTIONS
277/480 VOLT
THREE PHASE**

PANEL MOUNTED METER

CUSTOMER CONNECTION
CONNECTION TO MLCB

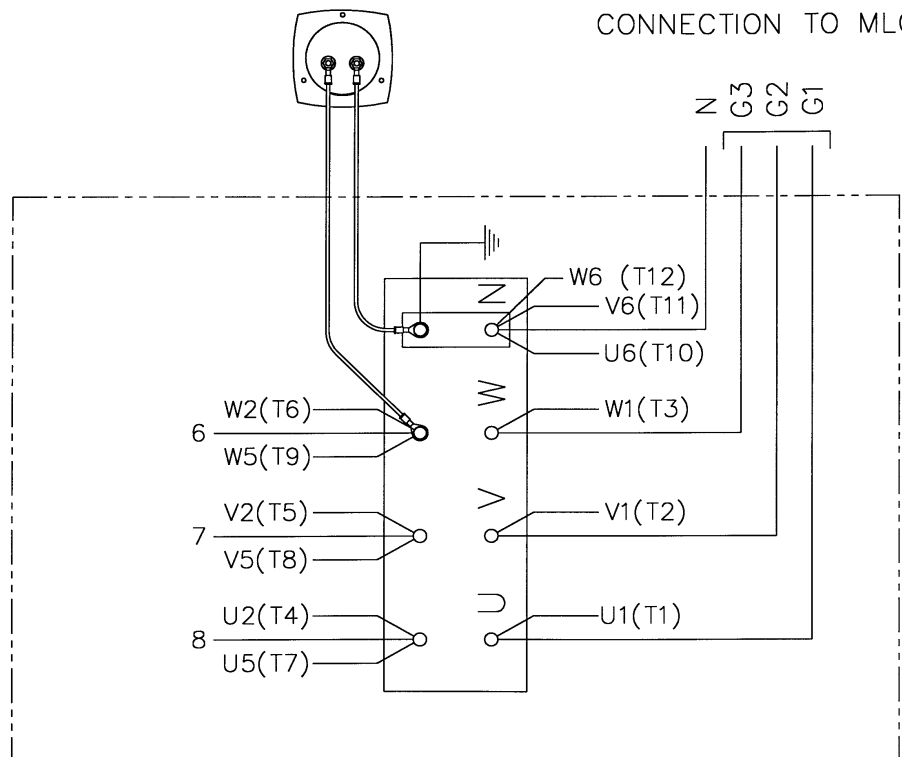

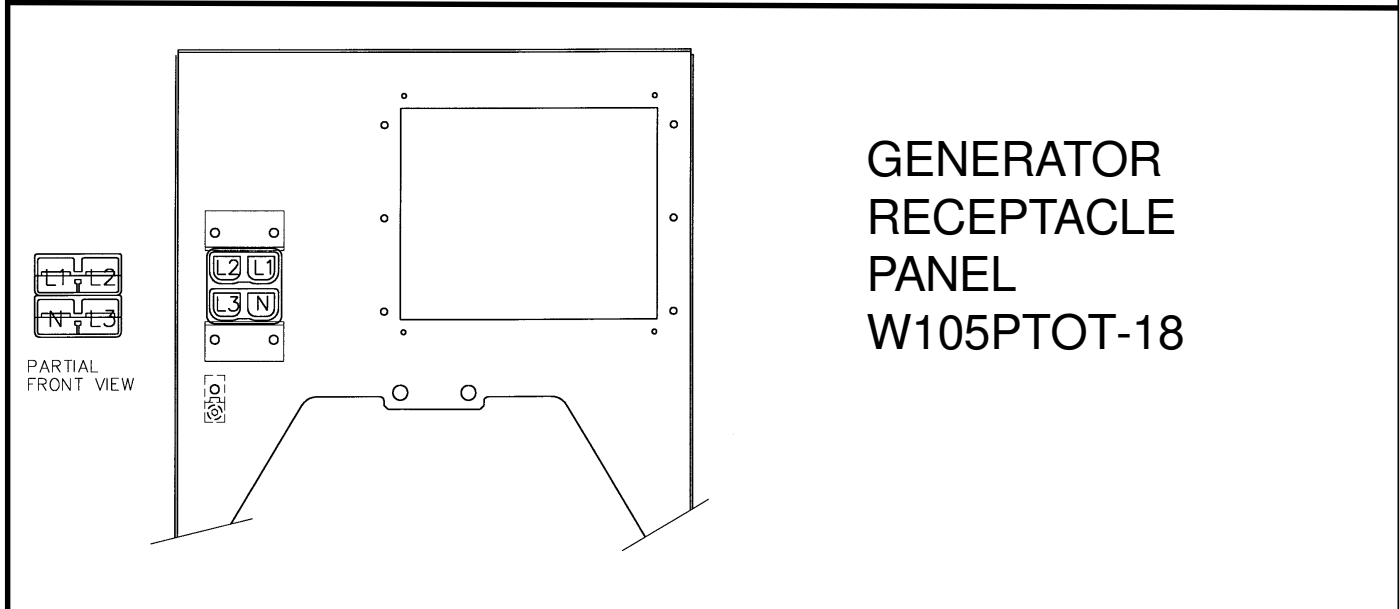
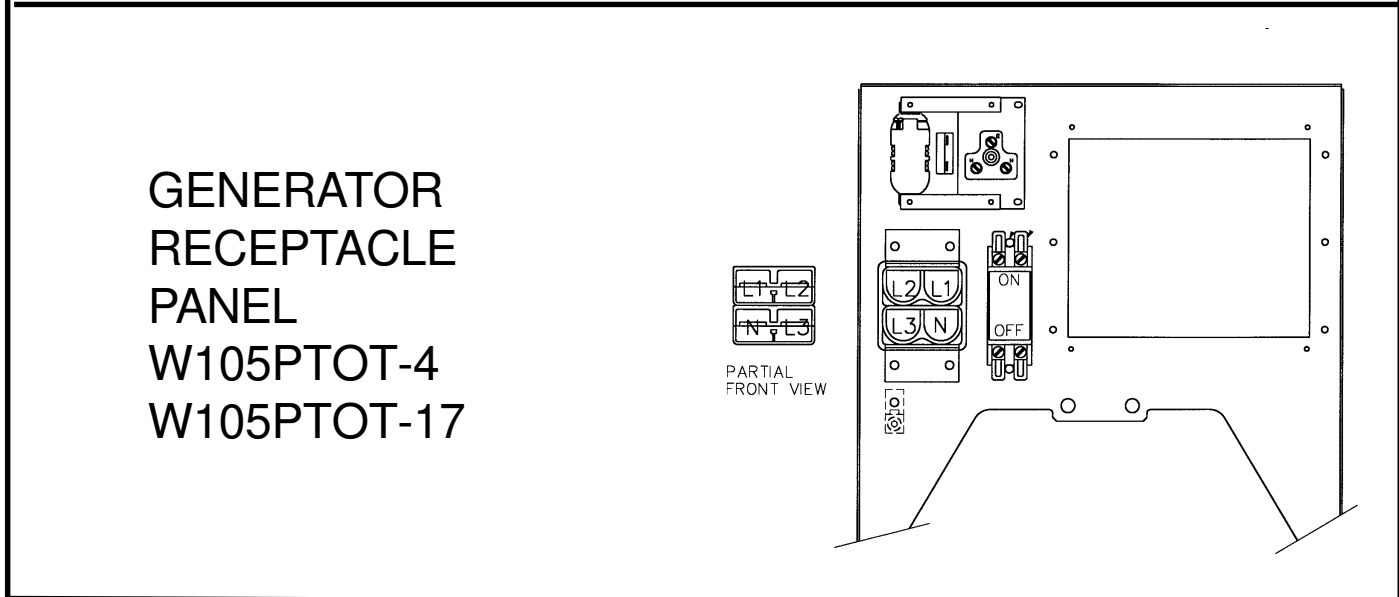
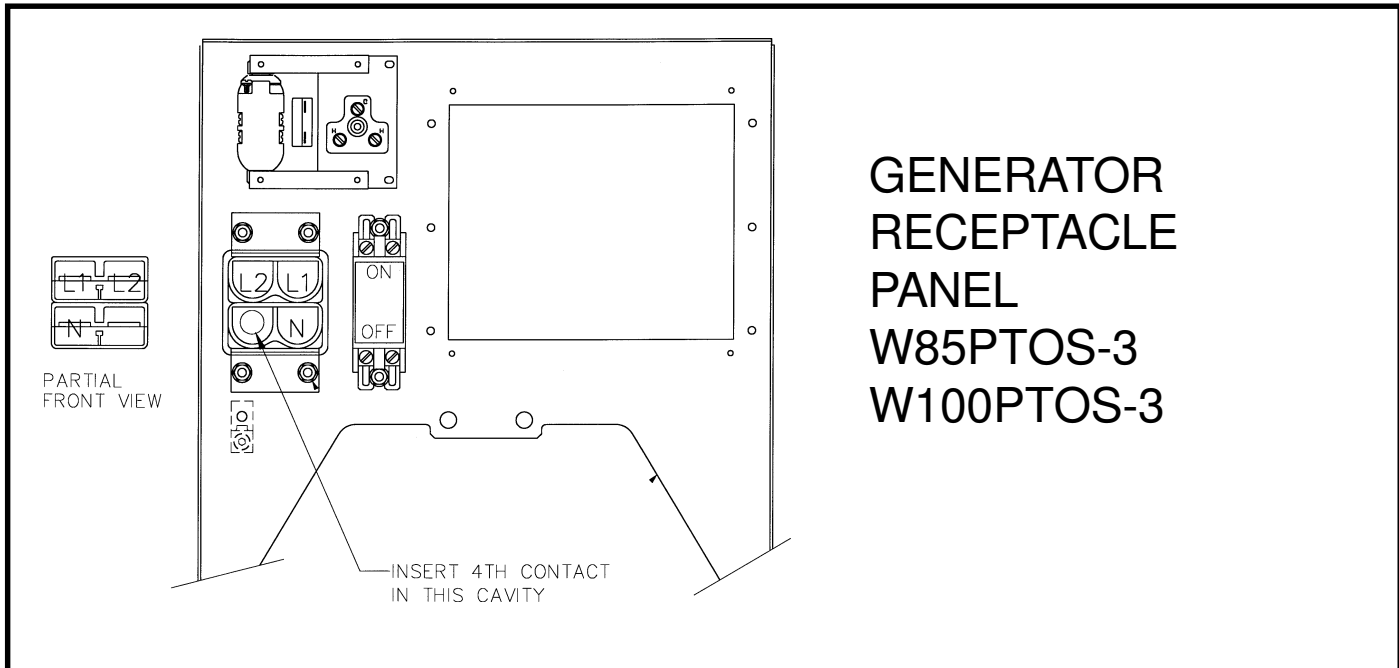

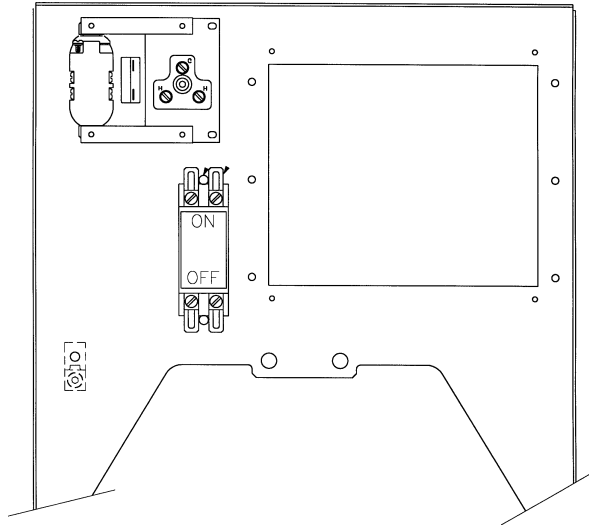

GENERATOR
RECEPTACLE
PANEL ON
MODELS
W135PTOS-3
W145PTOT-4
W145PTOT-17
W150PTOS-3

GENERATOR
RECEPTACLE
PANEL ON
MODEL
W165PTOT-18

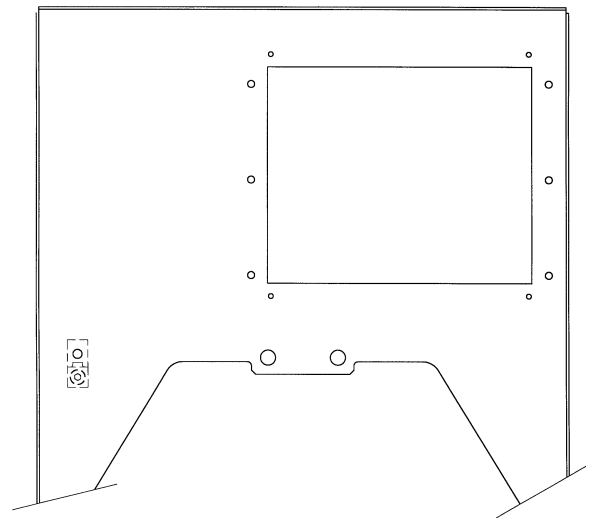

120 VOLT 20 AMP
RECEPTACLE & BREAKER

240 VOLT 50 AMP
RECEPTACLE & BREAKER

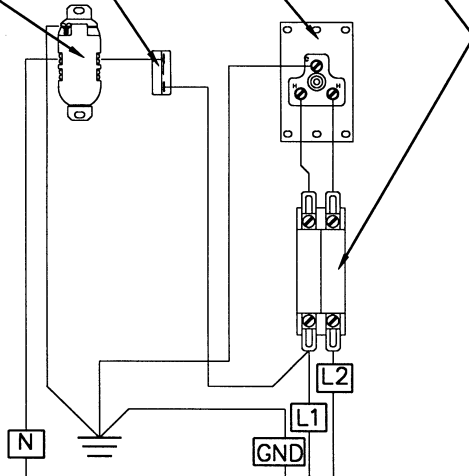

GENERATOR
CONVENIENCE
RECEPTACLE
WIRING ON ALL
MODELS EXCEPT
480 VOLT UNITS

WINCO PTO GENERATORS

36 MONTH LIMITED WARRANTY

WINCO, Inc., warrants for thirty-six months from date of shipment, that it will repair or replace at its option, for the original user, the whole or any part of the product found upon examination, by WINCO at its factory at 225 South Cordova Avenue, Le Center, Minnesota, or by any factory-authorized service station, to be defective in material or workmanship under normal standby use (average less than 50 hours per month) and service.

For warranty service, return the product within 36 months from the date of purchase, transportation charges prepaid, to your nearest factory-authorized service station or the WINCO factory.

There is no other express warranty. To the extent permitted by law, any and all warranties, including those of merchantability and fitness for a particular purpose, are limited to 36 months from date of shipment, and liability for incidental or consequential damages or expenses is excluded. Some states do not allow limitations on the duration of an implied warranty, and some states do not allow the exclusion or limitation of incidental or consequential damages, so that above limitation or exclusion may not apply to you. This warranty gives you specific legal rights; you may have other rights which vary from state to state.

This warranty is limited to bench labor and parts only, no allowance will be made for travel time, or removal and reinstallation of the PTO unit.

WINCO does not warrant drive lines, trailer tires, receptacles, or certain other component parts of the product installed by others, since such items are warranted by their manufacturers.

WINCO does not warrant modifications or alterations which were not made or authorized by the WINCO factory and which affect the stability or reliability of the product.

WINCO does not warrant products which have been exposed to misuse and/or negligence or have been involved in an accident.

WINCO does not warrant products which have been installed in such a manner as not to protect them from the adverse environmental conditions (water, mud, insects, etc.) or have not been kept clean.

WINCO reserves the right to change or improve its products without incurring any obligations to make such changes or improvements on products purchased previously.