

99840-003

USE 15209-003 FROM  
KIT 15209-000 AND  
DISCARD OTHERS

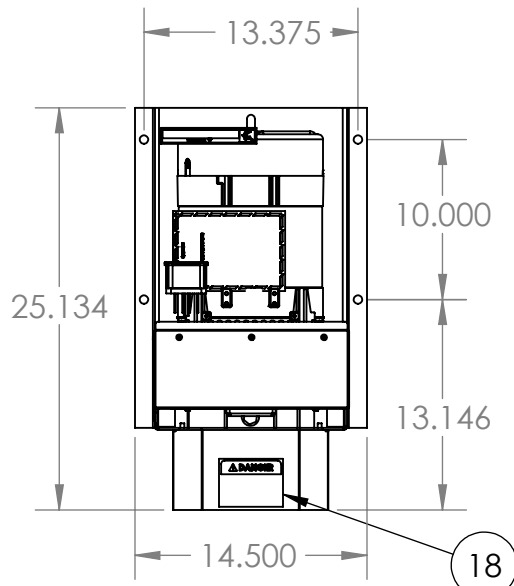

TORQUE  
THROUGH-BOLT  
TO 88.5 FT/LBS

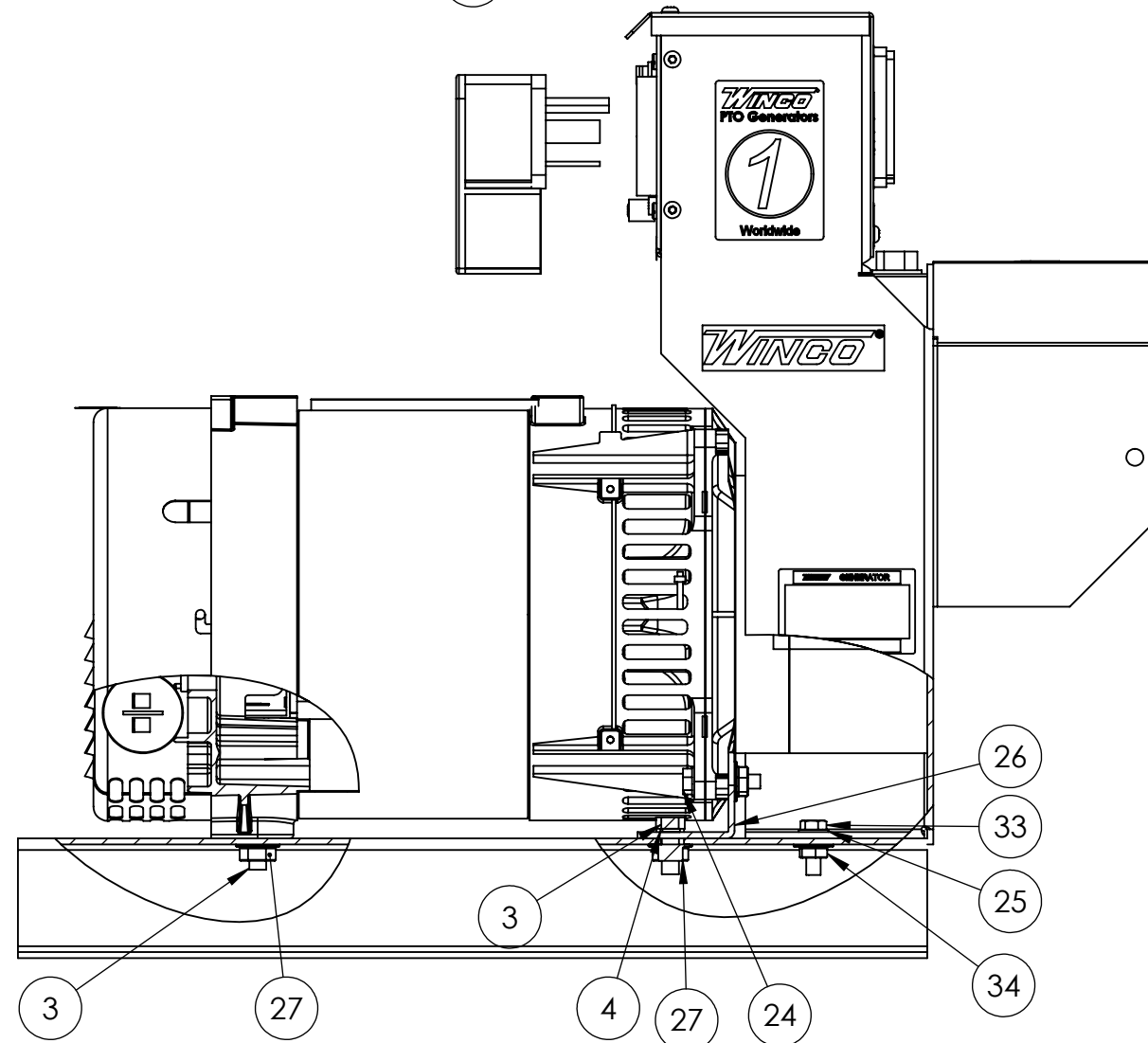
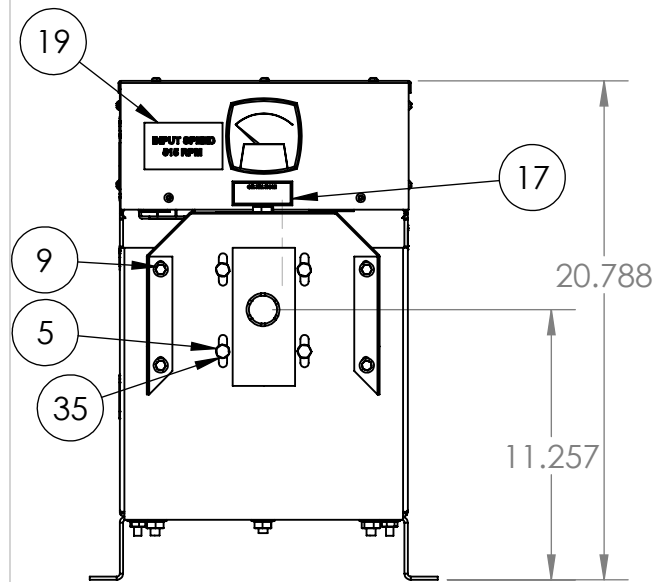
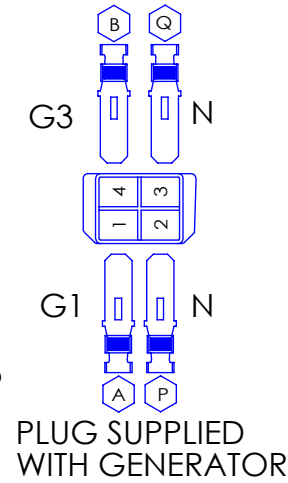
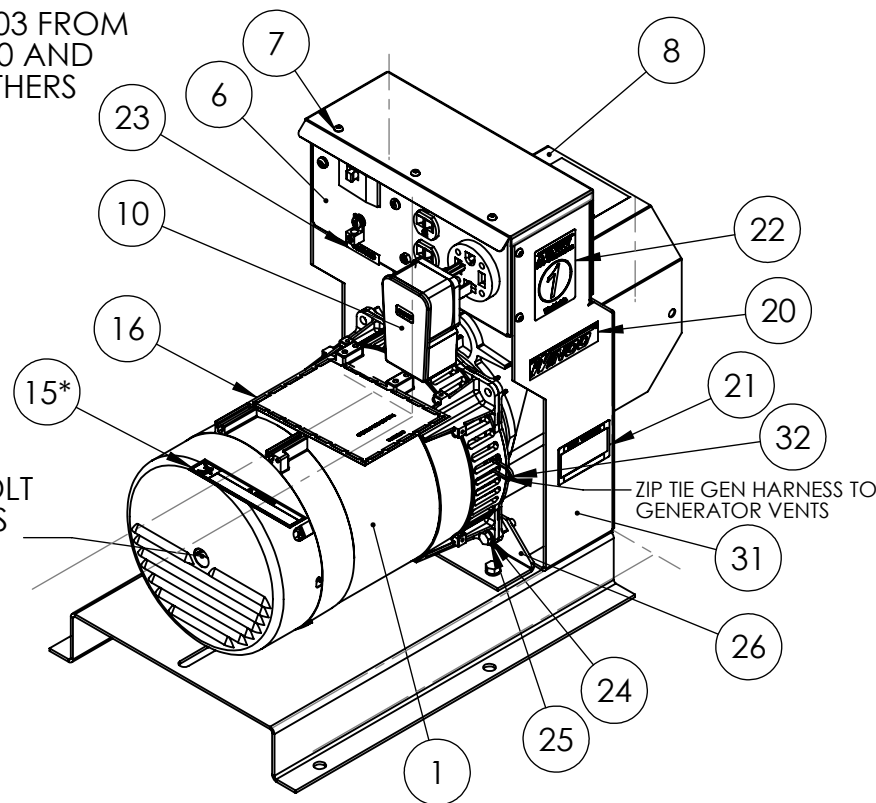

NOTE  
PLACE THE FOLLOWING INTO THE PARTS  
BOX CARTON:  
\*DRIVE SHAFT GUARD 300086-2, ITEM (8)  
\*SELF TAPPING SCREWS 55440-000, ITEM (9)  
\*14-60 RECEPTACLE PLUG 300137, ITEM (10)  
\*OPERATORS MANUAL

REVISIONS

REV.	IRN	DESCRIPTION	DATE	BY	APP'D
1		ORIGINAL	5/29/2013	MK	MVW
2	2211	INST 97436-008, 1116-000, 16249-000 AND DEL 4516-000, 21976-000, 6402-000, 5113-000	9/23/2013	MK	DRC

ITEM NO.	PartNo	DESCRIPTION	QTY.
1	99839-002	GEN END, 10.2 KW, W/GEARCASE	1
2	16406-007	FORMED BASE	1
3	91658-001	.375 - 16 X1 HHB	3
4	481-000	LOCK .375 SPLIT	3
5	96002-020	M8-1.25X20MM	4
6	300160-7	RECEPTACLE BOX ASSEMBLY	1
7	21698-001	10-16X.372 TORX SCREW BLACK	9
8	300086-2	GUARD, DRIVE SHAFT	1
9	55440-000	.25-02X.5 SELF TAP	4
10	300137	PLUG, NEMA 14-60P, 60A-3P-4W-125/250V	1
11	100047-747	CARTON PARTS BOX	1
12	40965-000	GEAR OIL	0.1875
13	100047-603	CARTON	1
14	15209-000	DECAL SET	1
15*	15209-003	UL-DECAL ELECTRICAL SHOCK CAN KILL	1
16	Z2553	DECAL-OPERATOR INSTRUCTIONS	1
17	Z9941	DECAL-OIL FILL HOLE	1
18	Z2568	DECAL-DANGER PTO	1
19	91369-003	UL-DECAL-515 RPM	1
20	53113-002	WINCO DECAL	2
21	63966-009	KIT, NAMEPLATE WINCO PTO	1
22	98479-000	WINCO #1 WORLDWIDE DECAL	1
23	15750-001	GROUND DECAL	1
24	468-000	.3125-18X1.5 HHCS	2
25	526-000	WASHER .3125 ID	4
26	16335-015	GENERATOR SUPPORT	1
27	16250-000	.375-16 FLANGE NUT	3
28	45633-000	RHMS 1/4-20X 5/8	3
29	638-000	.25-20 HEX NUT	2
30	100047-603	CARTON	1
31	99841-003	GEAR CASE SUPPORT	1
32	49975-012	CABLE TIE 14" BLACK 50# PULL	1
33	1116-000	HHCS .3125-18X1	2
34	16249-000	5/16"-18 FLANGE NUT	2
35	97436-008	LOCKWASHER M8	4

\* 15209-003 DECAL PART OF DECAL SET 15209-000

UNLESS OTHERWISE SPECIFIED		MACHINED SURFACE TEXTURE		ALL DIMENSIONS GIVEN IN INCHES WORK TO DIMENSIONS FLAT OUTSIDE VIEW SHOWN UNLESS NOTED -DO NOT SCALE-	
FRACTIONS 1 PLACE DEC. .1 2 PLACE DEC. .015 3 PLACE DEC. .005	ANGULAR 1.5				
	DRAWN BY MK	DATE 5/29/2013	CHK'D BY	DATE	ENG APPR. MVW
THIS DRAWING CONTAINS PROPRIETARY INFORMATION BELONGING TO WINCO. UNAUTHORIZED USE IS PROHIBITED	MATERIAL:	SEE TABLE		TITLE: COMPLETE ASSEMBLY W10PTOS	
	FINISH:	NA		PART NO. 99840-003	
	MODEL:	W10PTOS			