

HONDA

Power

Equipment

Owner's Manual

GENERATOR

EB4000X • EB5000X • EB6500X





WARNING:



The engine exhaust from this product contains chemicals known to the State of California to cause cancer, birth defects or other reproductive harm.

California Proposition 65

This product contains or emits chemicals known to the state of California to cause cancer, birth defects or other reproductive harm

⚠ WARNING

Exhaust contains poisonous carbon monoxide gas that can build up to dangerous levels in closed areas. Breathing carbon monoxide can cause unconsciousness or death.

Never run the generator in a closed, or even partly closed area where people may be present.

Keep this owner's manual handy so that you can refer to it at any time. This owner's manual is considered a permanent part of the generator and should remain with the generator if resold.

The information and specifications included in this publication were in effect at the time of approval for printing. Honda Motor Co., Ltd. reserves the right, however, to discontinue or change specifications or design at any time without notice and without incurring any obligation whatsoever.

INTRODUCTION

Congratulations on your selection of a Honda generator. We are certain you will be pleased with your purchase of one of the finest generators on the market.

We want to help you get the best results from your new generator and to operate it safely. This manual contains all the information on how to do that; please read it carefully.

As you read this manual, you will find information preceded by a **NOTICE** symbol. That information is intended to help you avoid damage to your generator, other property, or the environment.

We suggest you read the *Distributor's Limited Warranty* to fully understand its coverage and your responsibilities of ownership. The *Distributor's Limited Warranty* is a separate document that should have been given to you by your dealer.

When your generator needs scheduled maintenance, keep in mind that your Honda servicing dealer is specially trained in servicing Honda generators and is supported by the parts and service divisions of American Honda. Your Honda servicing dealer is dedicated to your satisfaction and will be pleased to answer your questions and concerns.

Best Wishes,
Honda Motor Co., Ltd.

A FEW WORDS ABOUT SAFETY

Your safety and the safety of others are very important. And using this generator safely is an important responsibility.

To help you make informed decisions about safety, we have provided operating procedures and other information on labels and in this manual. This information alerts you to potential hazards that could hurt you or others.

Of course, it is not practical or possible to warn you about all the hazards associated with operating or maintaining a generator. You must use your own good judgment.

You will find important safety information in a variety of forms, including:

- **Safety Labels** — on the generator.
- **Safety Messages** — preceded by a safety alert symbol  and one of three signal words, DANGER, WARNING, or CAUTION.

These signal words mean:

 **DANGER**

You WILL be KILLED or SERIOUSLY HURT if you don't follow instructions.

 **WARNING**

You CAN be KILLED or SERIOUSLY HURT if you don't follow instructions.

 **CAUTION**

You CAN be HURT if you don't follow instructions.

- **Safety Headings** — such as *IMPORTANT SAFETY INFORMATION*.
- **Safety Section** — such as *GENERATOR SAFETY*.
- **Instructions** — how to use this generator correctly and safely.

This entire book is filled with important safety information — please read it carefully.

CONTENTS

GENERATOR SAFETY	6
IMPORTANT SAFETY INFORMATION	6
Operator Responsibility.....	6
Carbon Monoxide Hazards.....	6
Electric Shock Hazards	7
Fire and Burn Hazards	7
Refuel With Care	8
SAFETY LABEL LOCATIONS	9
CONTROLS & FEATURES	10
COMPONENT & CONTROL LOCATIONS	10
CONTROLS	12
Engine Switch	12
Starter Grip.....	12
Fuel Valve Lever.....	13
Voltage Selector Switch	13
Auto Throttle System	14
AC Circuit Protectors	15
AC Circuit Breaker.....	16
Ground Fault Circuit Interrupter (GFCI).....	17
Folding Handle.....	19
FEATURES	20
Oil Alert System	20
Automatic Engine Stop Function.....	20
Oil Alert Function	20
Overspeed Detection Function	20
Abnormal Voltage Detection Function.....	20
Auto Choke and Throttle Control System.....	21
iAVR (Intelligent Auto Voltage Regulator)	21
Fuel Gauge	22
Ground Terminal.....	22
BEFORE OPERATION	23
ARE YOU READY TO GET STARTED?	23
Knowledge.....	23
IS YOUR GENERATOR READY TO GO?	23
Check the Engine	24
Check the GFCI.....	24

CONTENTS

OPERATION	25
SAFE OPERATING PRECAUTIONS.....	25
STARTING THE ENGINE	26
STOPPING THE ENGINE	29
GFCI OPERATION CHECK	30
GFCI System ①	
(120V-30A, 120V/240V-30A, 120V/240V-37.5A Receptacles).....	31
GFCI System ② (120V-20A Duplex Receptacle)	33
AC OPERATION.....	35
AC Applications.....	37
AC Receptacle Selection.....	38
Power Producing Circuits.....	38
Voltage Selector Switch	39
AUTO THROTTLE SYSTEM.....	41
STANDBY POWER.....	42
Connections to a Building's Electrical System	42
System Ground	42
Special Requirements.....	43
SERVICING YOUR GENERATOR	44
THE IMPORTANCE OF MAINTENANCE.....	44
MAINTENANCE SAFETY.....	45
Safety Precautions	45
MAINTENANCE SCHEDULE	46
REFUELING	47
FUEL RECOMMENDATIONS.....	48
ENGINE OIL LEVEL CHECK	49
ENGINE OIL CHANGE.....	50
ENGINE OIL RECOMMENDATIONS	51
AIR CLEANER SERVICE	52
AIR CLEANER ELEMENT CLEANING	54
SPARK PLUG SERVICE.....	55
SPARK ARRESTER SERVICE.....	57
SEDIMENT CUP CLEANING.....	58
STORAGE	59
STORAGE PREPARATION.....	59
Cleaning.....	59
Fuel.....	59
Engine Oil	62
Engine Cylinder.....	62
STORAGE PRECAUTIONS	63
REMOVAL FROM STORAGE.....	63

TRANSPORTING	64
TAKING CARE OF UNEXPECTED PROBLEMS	65
ENGINE WILL NOT START.....	65
ENGINE LACKS POWER.....	66
NO POWER AT THE AC RECEPTACLES.....	67
TECHNICAL INFORMATION	68
Serial Number Location	68
Carburetor Modification for High Altitude Operation.....	69
Emission Control System Information.....	70
Air Index	72
Specifications.....	73
Wiring Diagram.....	74
CONSUMER INFORMATION	76
Dealer Locator Information	76
Honda Publications.....	76
Customer Service Information.....	77
ASSEMBLY	78
SAFETY	78
The Importance of Proper Assembly	78
Important Safety Precautions	79
ASSEMBLY	80
Unpacking.....	80
Loose Parts (Wheel kit, handle and hanger).....	80
Wheel Kit Installation.....	81
Handle Installation	82
Hanger Kit Installation.....	83
INITIAL USE INSTRUCTIONS	84
ENGINE OIL.....	84
FUEL.....	85
BEFORE OPERATION.....	86
REGISTRATION.....	86
INDEX	87
QUICK REFERENCE INFORMATION	Inside back cover

GENERATOR SAFETY

IMPORTANT SAFETY INFORMATION

Honda generators are designed for use with electrical equipment that has suitable power requirements. Other uses can result in injury to the operator or damage to the generator and other property.

Most injuries or property damage can be prevented if you follow all instructions in this manual and on the generator. The most common hazards are discussed below, along with the best way to protect yourself and others.

Operator Responsibility

- Know how to stop the generator quickly in case of emergency.
- Understand the use of all generator controls, output receptacles, and connections.
- Be sure that anyone who operates the generator receives proper instruction. Do not let children operate the generator without parental supervision.

Carbon Monoxide Hazards

A generator's exhaust contains toxic carbon monoxide, which you cannot see or smell. Breathing carbon monoxide can **KILL YOU IN MINUTES**. To avoid carbon monoxide poisoning, follow these instructions when operating a generator:

- Only run a generator **OUTSIDE**, far away from windows, doors, and vents.
- Never operate a generator inside a house, garage, basement, crawl space, or any enclosed or partially enclosed space.
- Never operate a generator near open doors or windows.
- Get fresh air and seek medical attention immediately if you suspect you have inhaled carbon monoxide.

Early symptoms of carbon monoxide exposure include headache, fatigue, shortness of breath, nausea, and dizziness. Continued exposure to carbon monoxide can cause loss of muscular coordination, loss of consciousness, and then death.

To alert you to potentially dangerous levels of carbon monoxide coming from a generator operating outside, or from other sources, install battery operated carbon monoxide alarms or plug-in carbon monoxide alarms with battery back-up on every level of the home and outside sleeping areas in accordance with the manufacturer's instructions.

Electric Shock Hazards

- The generator produces enough electric power to cause a serious shock or electrocution if misused.
- Using a generator or electrical appliance in wet conditions, such as rain or snow, or near a pool or sprinkler system, or when your hands are wet, could result in electrocution. Keep the generator dry.
- If the generator is stored outdoors, unprotected from the weather, check the Ground Fault Circuit Interrupter (GFCI) receptacle and all other electrical components on the control panel before each use. Moisture or ice can cause a malfunction or short circuit in electrical components that could result in electrocution.
- Do not connect to a building's electrical system unless an isolation switch has been installed by a qualified electrician.

Fire and Burn Hazards

- The exhaust system gets hot enough to ignite some materials.
 - Keep the generator at least 3 feet (1 meter) away from buildings and other equipment during operation.
 - Do not enclose the generator in any structure.
 - Keep flammable materials away from the generator.
- The muffler becomes very hot during operation and remains hot for a while after stopping the engine. Be careful not to touch the muffler while it is hot. Let the engine cool before storing the generator indoors.

GENERATOR SAFETY

Refuel With Care

Gasoline is extremely flammable, and gasoline vapor can explode.

Do not refuel during operation.

Allow the engine to cool if it has been in operation.

Refuel only outdoors in a well-ventilated area and on a level surface.

Never smoke near gasoline, and keep other flames and sparks away.

Do not overfill the fuel tank.

Make sure that any spilled fuel has been wiped up before starting the engine.



Always store gasoline in an approved container.

GENERATOR SAFETY

SAFETY LABEL LOCATIONS



These labels warn you of potential hazards that can cause serious injury. Read them carefully.

If a label comes off or becomes hard to read, contact your Honda generator dealer for a replacement.

<p>⚠ WARNING</p> <p>Gasoline is highly flammable and explosive. You could be burned or seriously injured if the gasoline is ignited.</p> <ul style="list-style-type: none"> ■ Before refueling, stop the engine and keep heat, sparks, and flame away. ■ Handle fuel only outdoors. ■ Do not fill the fuel tank above the upper limit line. ■ Wipe up spills immediately. 	<p>⚠ WARNING</p> <p>Improper connections to a building can allow electrical current to backfeed into utility lines, creating an electrocution hazard.</p> <ul style="list-style-type: none"> ■ Connections to a building must isolate generator power from utility power and comply with all applicable laws and electrical codes.
<p> Exhaust contains poisonous carbon monoxide gas that can build up to dangerous levels in closed areas. Breathing carbon monoxide can cause unconsciousness or death.</p> <ul style="list-style-type: none"> ■ Never run the generator in a closed, or even partly closed area where people may be present. 	<p> The generator is a potential source of electrical shock if not kept dry or cover is removed.</p> <ul style="list-style-type: none"> ■ Do not expose the generator to moisture, rain or snow. ■ Do not operate the generator with wet hands. ■ Do not remove covers when engine is running. <p>You risk electric shock if you operate this generator with a faulty GFCI (Ground-Fault Circuit-Interrupter).</p> <ul style="list-style-type: none"> ■ Test GFCI before each use. ■ If GFCI fails test, do not use your generator. See your Honda dealer.
<p> Read owner's manual carefully before operation.</p>	

⚠ DANGER

Using a generator indoors CAN KILL YOU IN MINUTES. Generator exhaust contains carbon monoxide. This is a poison you cannot see or smell.

	
<p>NEVER use inside a home or garage, EVEN IF doors and windows are open.</p>	<p>Only use OUTSIDE and far away from windows, doors, and vents.</p>

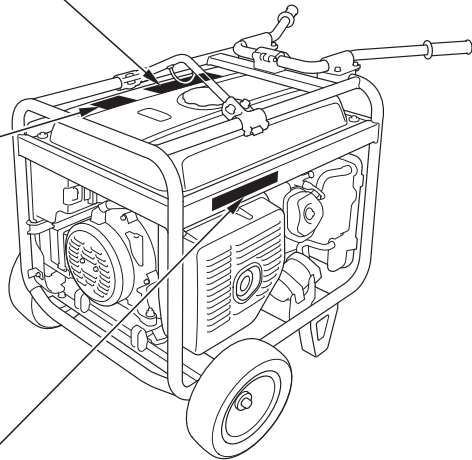

<p>⚠ WARNING</p> <p>Operation of This Equipment May Create Sparks That Can Start Fires Around Dry Vegetation. A Spark Arrestor May be Required. The Operator Should Contact Local Fire Agencies For Laws or Regulations Relating to Fire Prevention Requirements.</p> <p><small>Per California Public Resources Code 4442.6</small></p>		<p>⚠ CAUTION</p> <p>A hot exhaust system can cause serious burns.</p> <ul style="list-style-type: none"> ■ Avoid contact if the engine has been running.
--	---	--

CONTROLS & FEATURES

COMPONENT & CONTROL LOCATIONS

Use the illustrations on these pages to locate and identify the most frequently used controls.

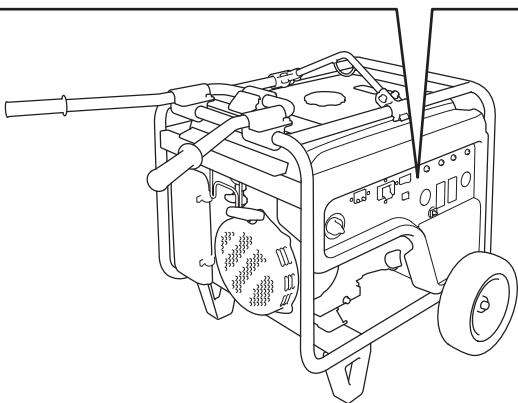
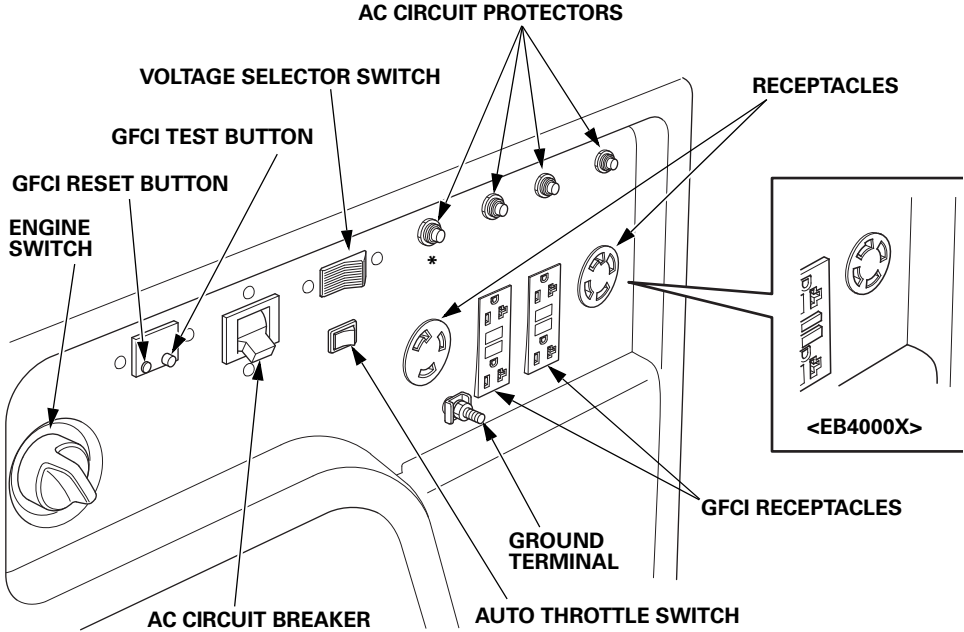

*: Except EB4000X

CONTROLS & FEATURES

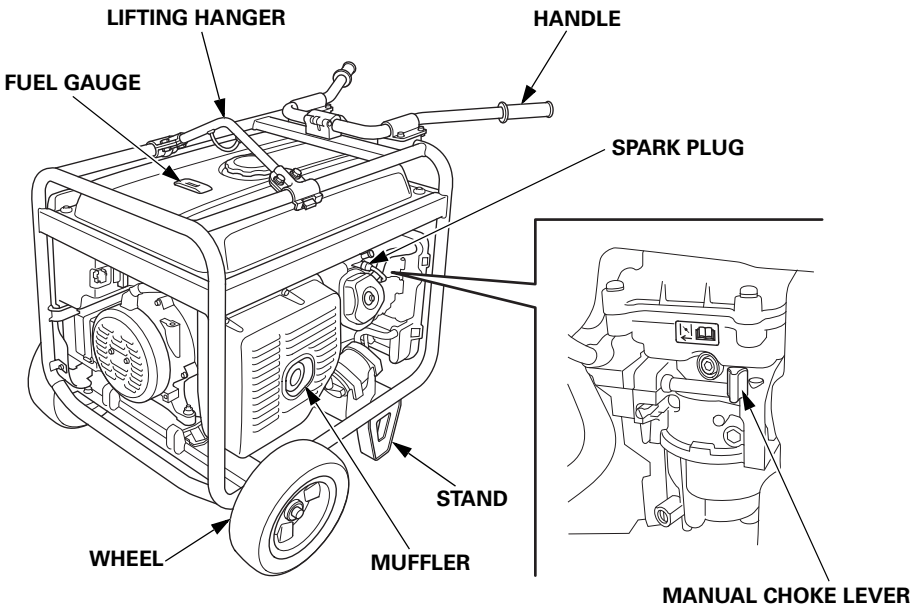
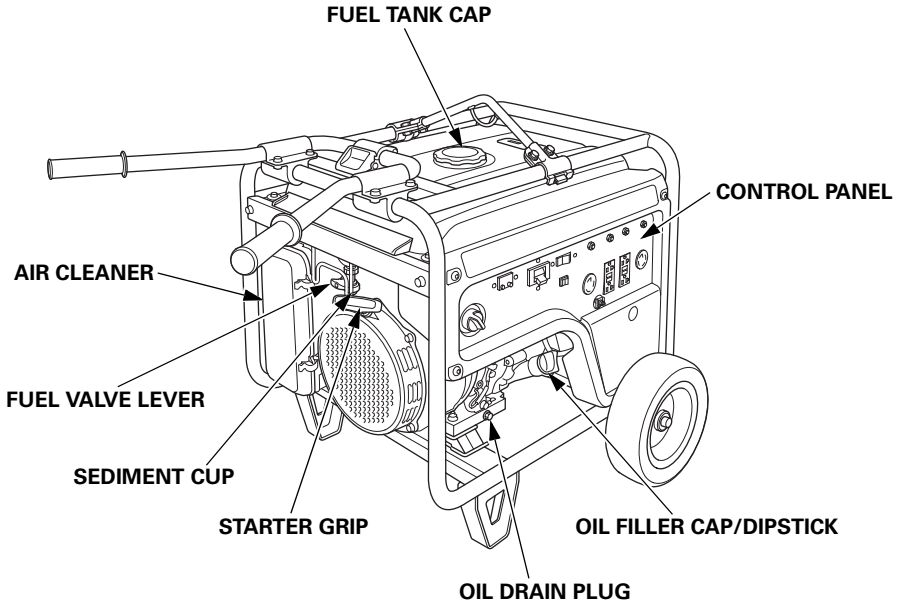

CONTROLS & FEATURES

CONTROLS

Engine Switch

The engine switch controls the ignition system.

OFF – Stops the engine.

ON – Running position, and for starting.

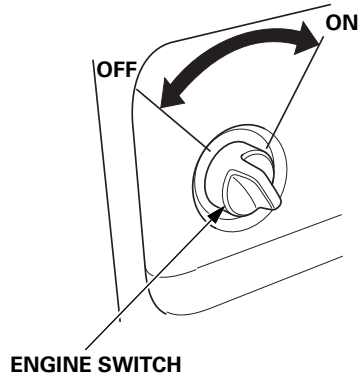

Starter Grip

Pulling the starter grip operates the recoil starter to crank the engine.

NOTICE

- *Do not allow the starter grip to snap back against the generator. Return it gently to prevent damage to the starter.*
- *Do not let the starter rope rub against the generator body, or the rope will wear out prematurely.*
- *Be careful not to hit your hand against the handle when pulling the starter grip.*

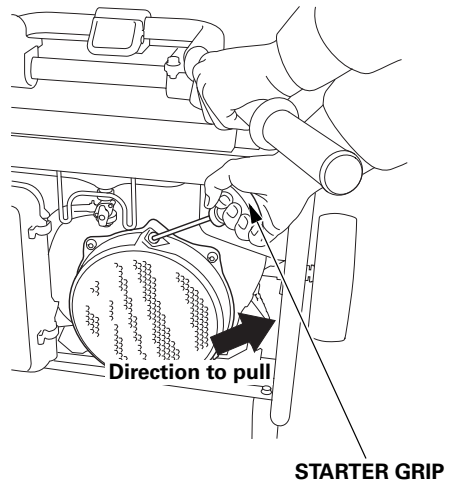

Fuel Valve Lever

The fuel valve lever is located between the fuel tank and carburetor.

The fuel valve must be in the ON position for the engine to run.

After stopping the engine, turn the fuel valve to the OFF position.

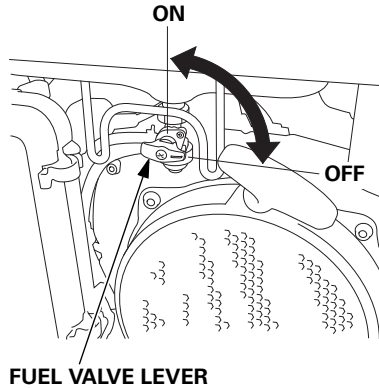

Voltage Selector Switch

The voltage selector switch switches generator output to produce "120V ONLY" or "120V/240V." If a 240V appliance is connected to the 4-prong receptacle, the switch must be in the "120V/240V" position. If only a 120V appliance is being connected to any of the 120V 3-prong receptacles, select the "120V ONLY" position. Select the voltage before starting the engine.

Switch Position

120V/240V: The 120V and 120V/240V receptacles can be used simultaneously.

120V ONLY: ONLY 120 volts is available in this position; 240 volts is not available. The most power will be available at the 30A 120V locking plug receptacle.

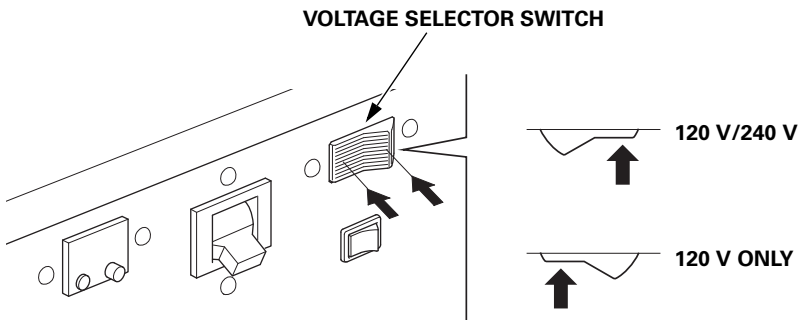

CONTROLS & FEATURES

Auto Throttle[®] System

The Auto Throttle[®] system automatically reduces engine speed when all loads are turned off or disconnected. When appliances are turned on or reconnected, the engine returns to the rated speed.

Switch Position

- ON:** Recommended to minimize fuel consumption and further reduce noise levels when no load is applied to the generator.
- OFF:** The Auto Throttle system does not operate. Recommended to minimize warm-up time when the generator is started and when starting a load with large start-up power requirements.

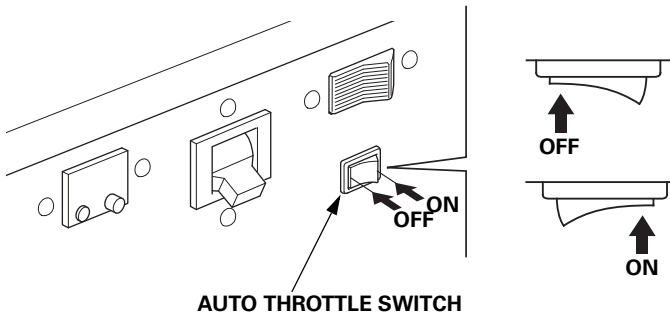

CONTROLS & FEATURES

AC Circuit Protectors

The AC circuit protectors will automatically switch OFF if there is a short circuit or a significant overload of the generator at each receptacle. If an AC circuit protector switches OFF automatically, check that the appliance is working properly and does not exceed the rated load capacity of the circuit before resetting the AC circuit protector ON.

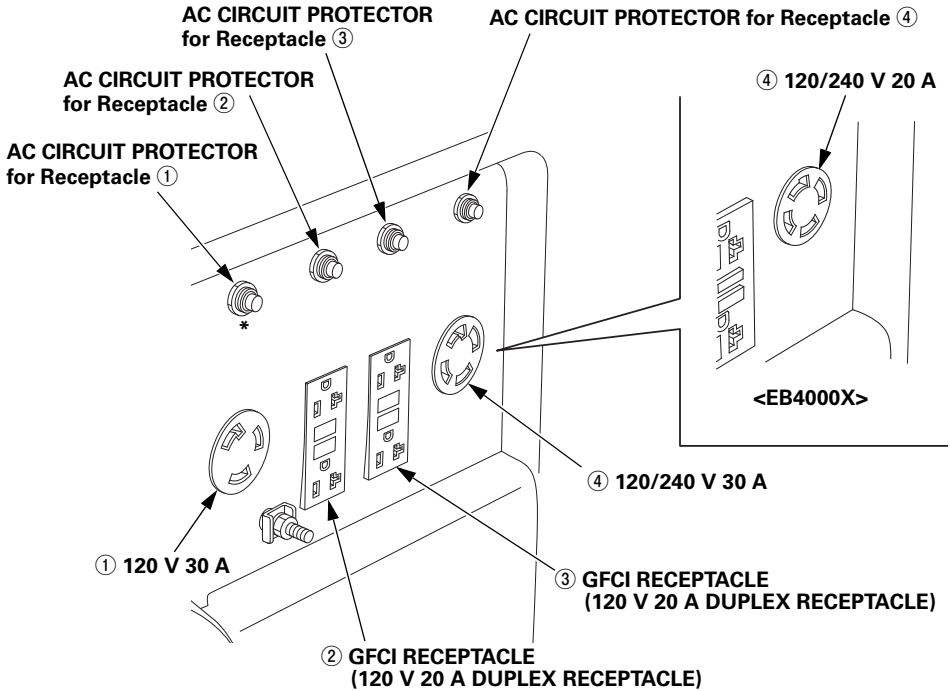

*: Except EB4000X

AC CIRCUIT PROTECTOR

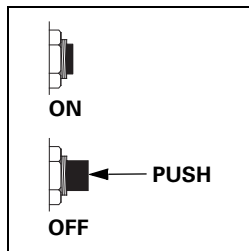

CONTROLS & FEATURES

AC Circuit Breaker

The AC circuit breaker will automatically switch OFF in the following cases.

- If there is a short circuit or a significant overload at the receptacles.
- If there is a ground-fault current from either receptacles A or B.

The AC circuit breaker may be used to switch the generator power ON or OFF.

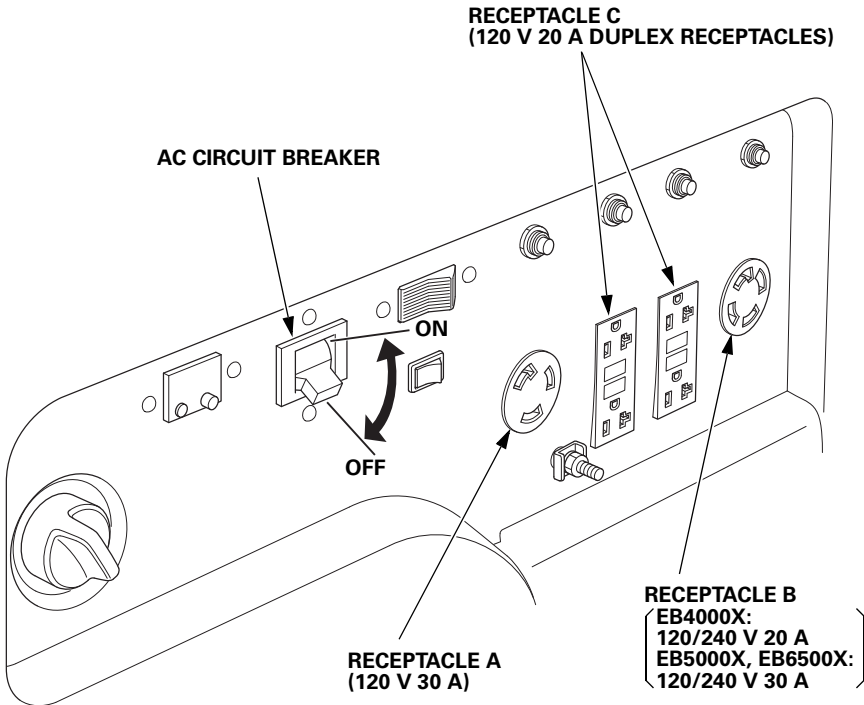

Ground Fault Circuit Interrupter (GFCI)

This generator has two types of Ground Fault Circuit Interrupter (GFCI) systems, GFCI system ① and GFCI system ② .

GFCI System ①

(120V-30A, 120V/240V-20A (EB4000X),
120V/240V-30A (EB5000X, EB6500X) RECEPTACLES)

If there is a ground-fault current from either A or B receptacle, it will shut off the power to receptacles A and B.

If this GFCI system ① activates, the AC circuit breaker will be switched to OFF position and it will shut off power to all receptacles, including GFCI system ② 120 V 20 A DUPLEX RECEPTACLES.

GFCI System ②

(120V-20A DUPLEX RECEPTACLE)

If there is a ground-fault current from either 120 V 20 A DUPLEX RECEPTACLE, then the GFCI System ② will shut off the power to that 120 V 20 A DUPLEX RECEPTACLE. GFCI system ① will not be affected.

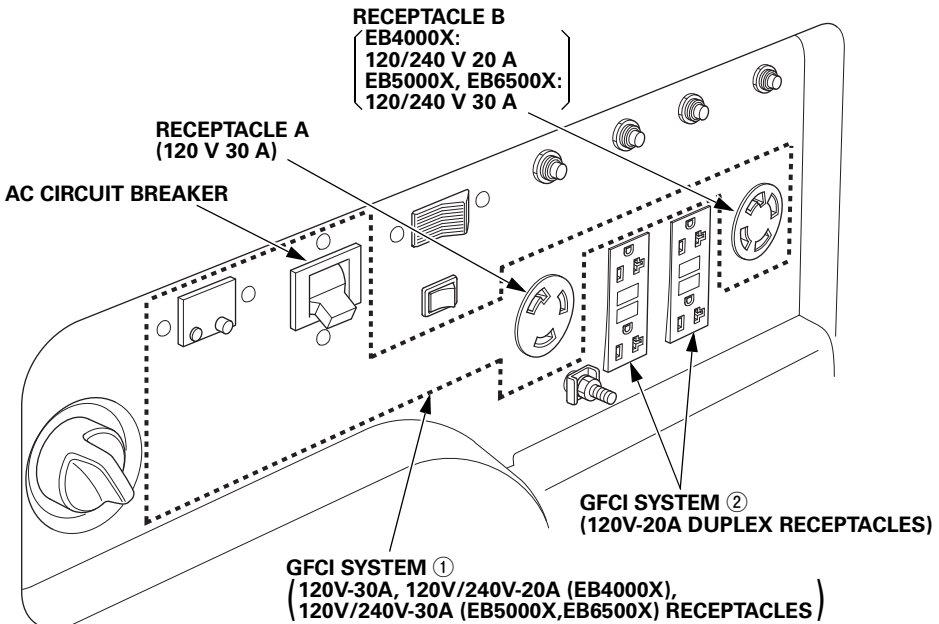

CONTROLS & FEATURES

All receptacles on the generator are protected by a Ground Fault Circuit Interrupter (GFCI) for protection against the shock hazard of ground-fault current.

An example of ground-fault current is the current that would flow through a person who is using an appliance with faulty insulation and, at the same time, is in contact with an electrical ground such as a plumbing fixture, wet floor, or earth. The GFCI will protect against current flowing through that person.

The GFCI will not protect against short circuits or overloads.

GFCIs can be expected to interrupt power supply if there are ground faults or stray current imposed on the wiring by other electrical devices, wiring, or equipment. Due to the risk of a power interruption, this generator is not recommended for powering medical or life support equipment.

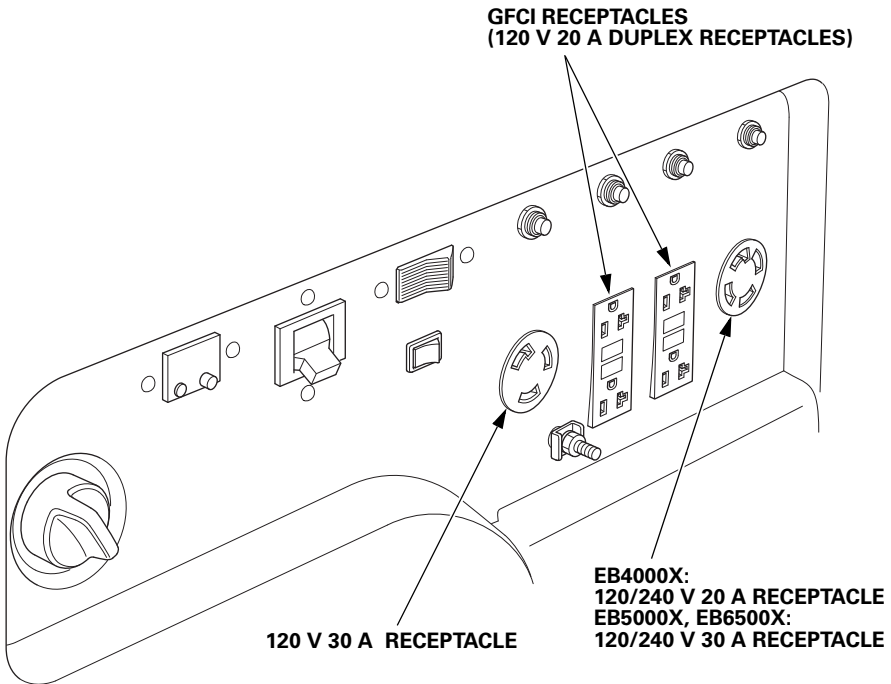

Folding Handle

The foldable handle is intended for ease of transportation and should be folded when the generator is stationary. Do not rest objects on the extended handle.

To Extend The Handle

Lift handle upward. Lock lever will lock and secure the handle into place.

To Fold The Handle

1. Press handle lock lever downward.
2. Lower the handle.

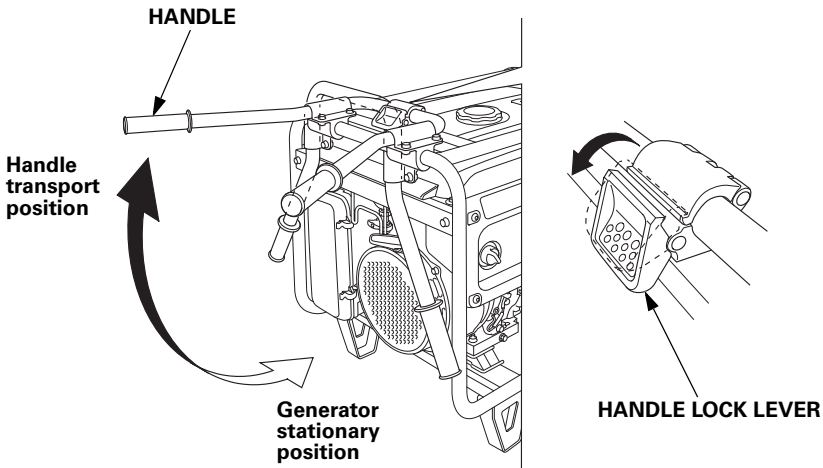

CONTROLS & FEATURES

FEATURES

Oil Alert[®] System

The Oil Alert[®] system is designed to prevent engine damage caused by an insufficient amount of oil in the crankcase. Before the oil level in the crankcase can fall below a safe limit, the Oil Alert system will automatically stop the engine (the engine switch will remain in the ON position).

If the engine stops and will not restart, check the engine oil level (see page 49) before troubleshooting in other areas.

Automatic Engine Stop Function

Oil Alert Function

During operation, the engine will automatically stop if there is not enough oil in the tank. Moreover, if the generator is on a slope, the oil alert function may operate and stop the engine.

Overspeed Detection Function

To protect the engine from exceeding the engine load, the engine will automatically stop if the engine speed becomes abnormal.

Abnormal Voltage Detection Function

The engine will automatically stop during generation when it detects abnormal voltage.

If the engine stops, make sure the oil level is correct. Wait a few minutes, and then try to restart the engine. If the engine still won't start, take the generator to your authorized servicing Honda power equipment dealer.

Auto Choke and Throttle Control System

The ECM of this engine controls the choke valve and throttle automatically.

When starting and warming up the engine, you do not need to operate the choke lever unless the engine is hard to start using the normal starting procedure.

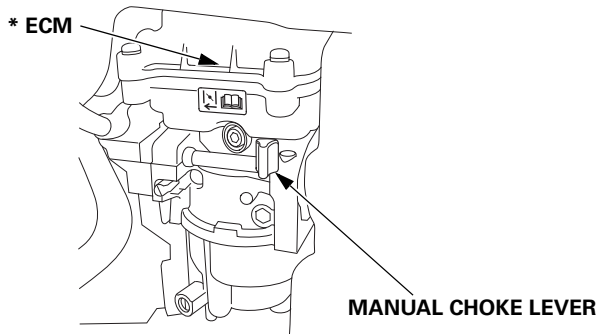

* ECM: Engine Control Module

iAVR (Intelligent Auto Voltage Regulator)

This generator is equipped with an intelligent, automatic voltage regulator. The iAVR provides power in excess of the maximum rating for up to ten seconds to start appliances that require high startup current.

The total amount of power available for each generator model is:

EB4000X: 5,000 watts for up to 10 seconds

EB5000X: 7,000 watts for up to 10 seconds

EB6500X: 7,000 watts for up to 10 seconds

CONTROLS & FEATURES

Fuel Gauge

The fuel gauge is a mechanical device that measures the fuel level in the tank. The red indicator in the window will reference the level in relation to full or empty. To provide increased operating time, start with a full tank before beginning operation. Check the fuel level with the generator on a level surface. Always refuel with the engine OFF and cool.

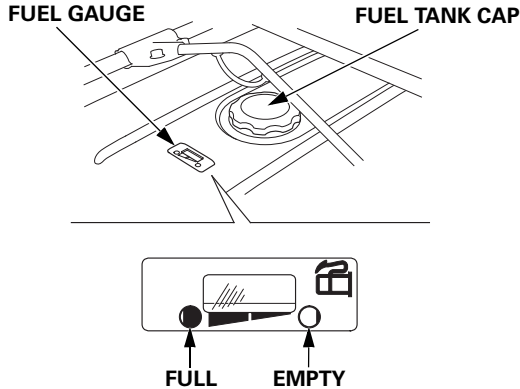

Ground Terminal

The generator ground terminal is connected to the frame of the generator, the metal non-current-carrying parts of the generator, and the ground terminals of each receptacle.

Before using the ground terminal, consult a qualified electrician, electrical inspector, or local agency having jurisdiction for local codes or ordinances that apply to the intended use of the generator.

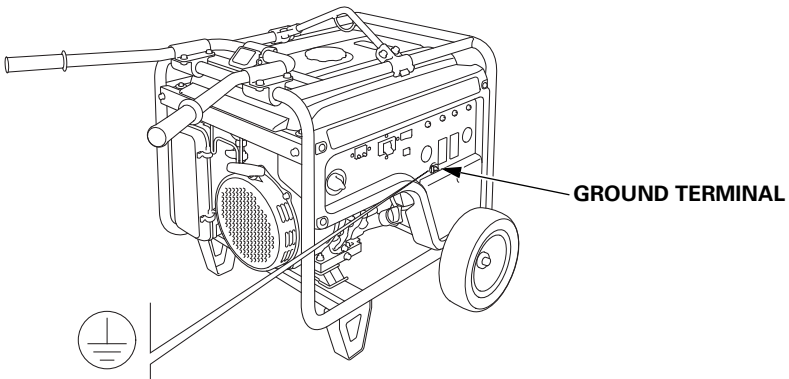

BEFORE OPERATION

ARE YOU READY TO GET STARTED?

Your safety is your responsibility. A little time spent in preparation will significantly reduce your risk of injury.

Knowledge

Read and understand this manual. Know what the controls do and how to operate them.

Familiarize yourself with the generator and its operation before you begin using it. Know how to quickly shut off the generator in case of an emergency.

If the generator is being used to power appliances, be sure that they do not exceed the generator's load rating (see page 37).

IS YOUR GENERATOR READY TO GO?

For your safety, to ensure compliance with environmental regulations, and to maximize the service life of your equipment, it is very important to take a few moments before you operate the generator to check its condition. Be sure to take care of any problem you find, or have your servicing dealer correct it, before you operate the generator.

⚠ WARNING

Failure to properly maintain this generator, or failing to correct a problem before operation, could result in a significant malfunction.

Some malfunctions can seriously hurt or kill you.

Always perform a pre-operation inspection before each operation and correct any problems.

BEFORE OPERATION

To prevent a possible fire, keep the generator at least 3 feet (1 meter) away from building walls and other equipment during operation. Do not place flammable objects close to the engine.

Before beginning your pre-operation checks, be sure the generator is on a level surface and the engine switch is in the OFF position.

Check the Engine

- Before each use, look around and underneath the engine for signs of oil or gasoline leaks.
- Check the oil level (see page 49). A low oil level will cause the Oil Alert system to shut down the engine or prevent it from starting.
- Check the air cleaner (see page 52). A dirty air cleaner element will restrict air flow to the carburetor, reducing engine and generator performance.
- Check the fuel level (see page 47). Starting with a full tank will help to eliminate or reduce operating interruptions for refueling.

Check the GFCI

Check the GFCI operation (see page 30) after starting the engine.

OPERATION

SAFE OPERATING PRECAUTIONS

Before operating the generator for the first time, review chapters *GENERATOR SAFETY* (see page 6) and *BEFORE OPERATION* (see page 23).

For your safety, do not operate the generator in an enclosed area such as a garage. Your generator's exhaust contains poisonous carbon monoxide gas that can collect rapidly in an enclosed area and cause illness or death.

⚠ WARNING

Exhaust contains poisonous carbon monoxide gas that can build up to dangerous levels in closed areas.

Breathing carbon monoxide can cause unconsciousness or death.

Never run the generator in a closed, or even partly closed area where people may be present.

Before connecting an AC appliance or power cord to the generator:

- Use grounded 3-prong extension cords, tools, and appliances, or double-insulated tools and appliances.
- Inspect cords and plugs, and replace if damaged.
- Do not use cord lengths greater than 164 feet (50 meters), and do not use multiple tools and appliances with built-in noise filters. Such use may activate the GFCI and trip the circuit breaker.
- Make sure that the appliance is in good working order. Faulty appliances or power cords can create a potential for electric shock.
- Make sure the electrical rating of the tool or appliance does not exceed the rated power of the generator or the receptacle being used.
- Operate the generator at least 3 feet (1 meter) away from buildings and other equipment.
- Do not operate the generator in an enclosed structure.
- Do not place flammable objects close to the engine or locate the generator near flammable materials.

OPERATION

STARTING THE ENGINE

To prevent a possible fire, keep the generator at least 3 feet (1 meter) away from building walls and other equipment during operation. Do not place flammable objects close to the engine.

NOTICE

Operating this generator less than 3 feet (1 meter) from a building or other obstruction can cause overheating and damage the generator. For proper cooling, allow at least 3 feet (1 meter) of empty space above and around the generator.

Refer to *SAFE OPERATING PRECAUTIONS* on page 25 and perform the *IS YOUR GENERATOR READY TO GO?* checks (see page 23). Refer to *AC OPERATION* (see page 35) for connecting loads to the generator.

1. Make sure that all appliances are disconnected from the AC receptacle.

2. Make sure that the AC circuit breaker is in the OFF position.

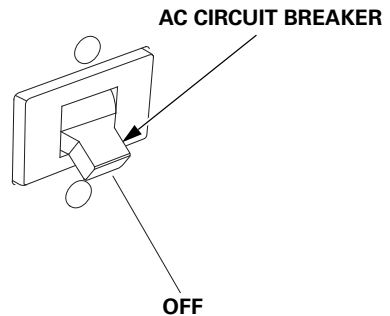

3. Turn the fuel valve lever to the ON position.

FUEL VALVE LEVER

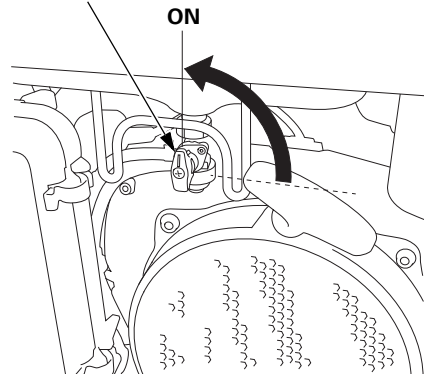

4. Make sure the Auto Throttle switch is in the OFF position, or more time will be required for warm up.

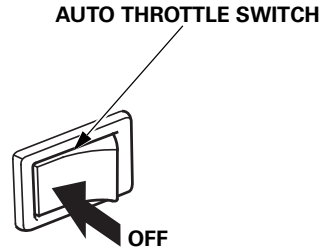

5. Turn the engine switch to the ON position.

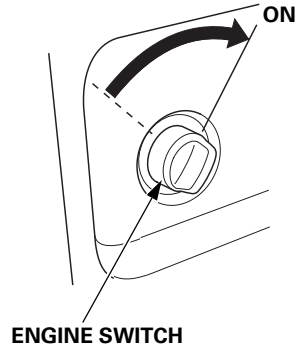

6. Pull the starter grip lightly until you feel resistance; then pull briskly in the direction of the arrow as shown.

NOTICE

- *Do not allow the starter grip to snap back against the engine. Return it gently to prevent damage to the starter.*
- *Do not let the starter rope rub against the generator body, or the rope will wear out prematurely.*
- *Be careful not to hit your hand against the handle when pulling the starter grip.*

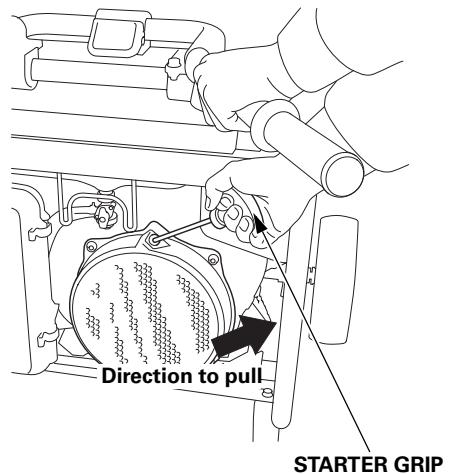

OPERATION

7. If you wish to use the Auto Throttle system, turn the Auto Throttle switch to the ON position after the engine has warmed up for 2 or 3 minutes.

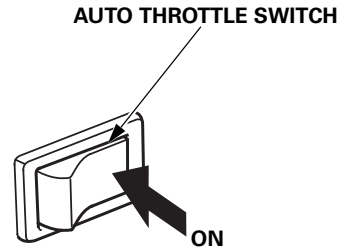

STOPPING THE ENGINE

To stop the engine in an emergency, simply turn the engine switch to the OFF position. Under normal conditions, use the following procedure.

1. Turn off or disconnect all appliances that are connected to the generator.
2. Move the AC circuit breaker to the OFF position.

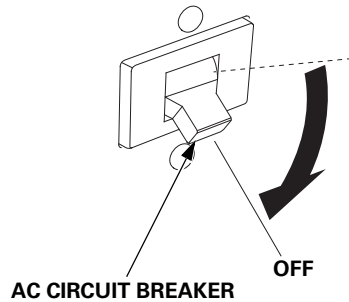

3. Turn the engine switch to the OFF position.

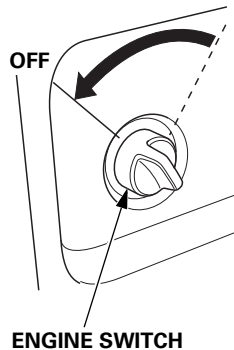

4. Turn the fuel valve lever to the OFF position.

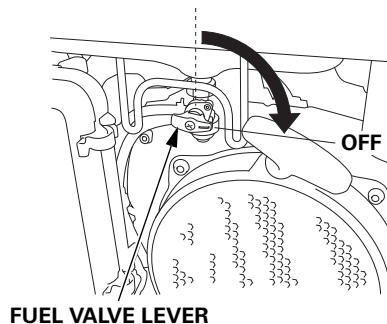

OPERATION

GFCI OPERATION CHECK

Always check GFCI system ① and GFCI system ② operation before using the generator.

⚠ WARNING

A faulty GFCI system will not provide proper protection against electric shock as designed.

An electric shock can result in serious injury or death.

Always perform the GFCI system inspection before using the generator. If the GFCI system fails the test, the generator must be repaired by an authorized Honda servicing dealer before use.

GFCI SYSTEM ①
(120V-30A, 120V/240V-20A (EB4000X),
120V/240V-30A (EB5000X,EB6500X) RECEPTACLES)

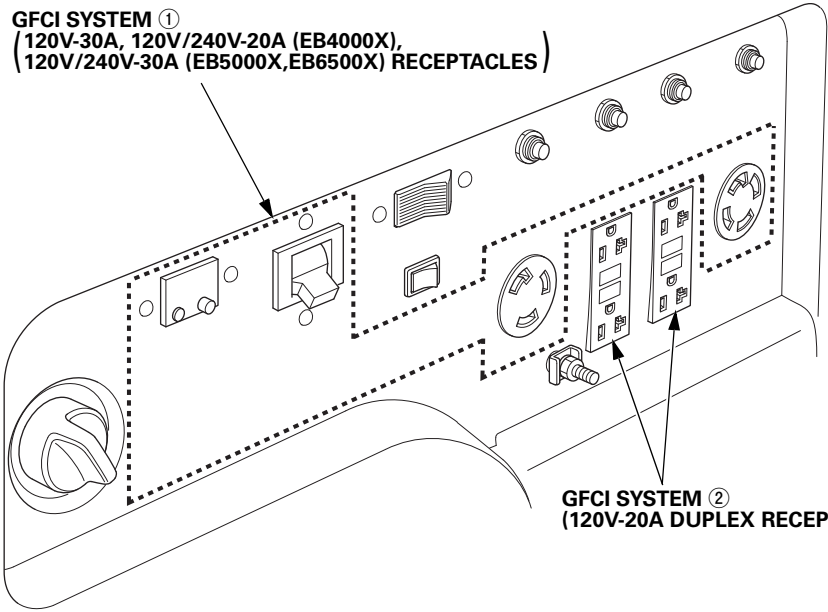

GFCI SYSTEM ②
(120V-20A DUPLEX RECEPTACLES)

GFCI System ① (120V-30A, 120V/240V-20A (EB4000X), 120V/240V-30A (EB5000X, EB6500X) Receptacles)

1. Unplug all tools and appliances from the generator.
2. Start the engine (see page 26).
3. Turn the AC circuit breaker to the ON position.
4. Turn OFF the Auto Throttle switch (see page 27).

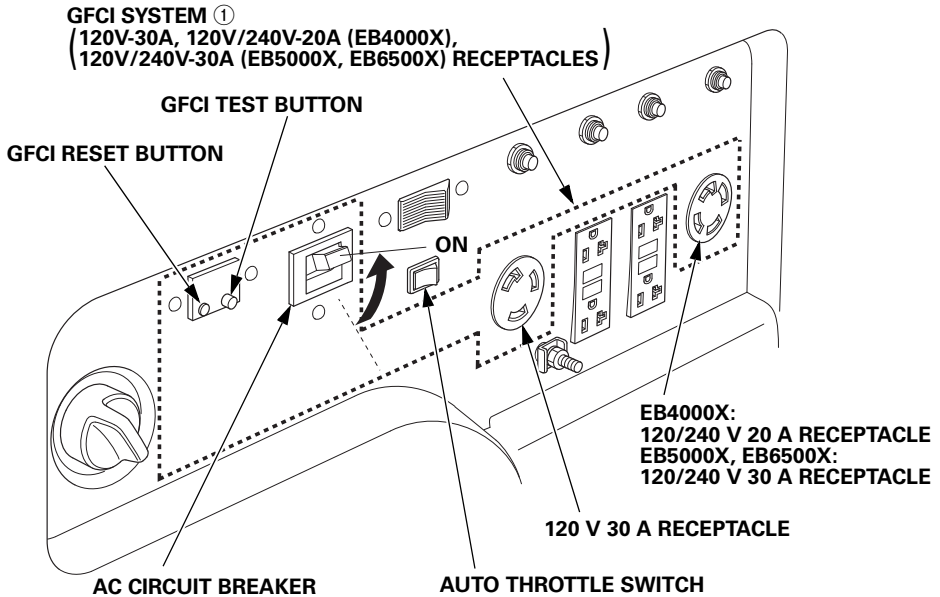

5. Press the GFCI TEST button:
 - The RESET button should extend, and the AC circuit breaker should switch to the OFF position.
 - If the GFCI and AC circuit breaker do not function as described, take the generator to an authorized Honda generator dealer for repair.

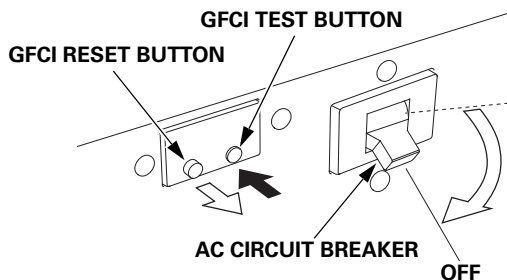

OPERATION

6. Press the GFCI RESET button:

- The RESET button should stay in, flush with its base plate.
- With the RESET button in and the engine running, turn the AC circuit breaker to the ON position. The AC circuit breaker should remain in the ON position. The AC circuit breaker will not remain in the ON position if the RESET button is extended.
- If the GFCI and AC circuit breaker do not function as described, take the generator to an authorized Honda generator dealer for repair.

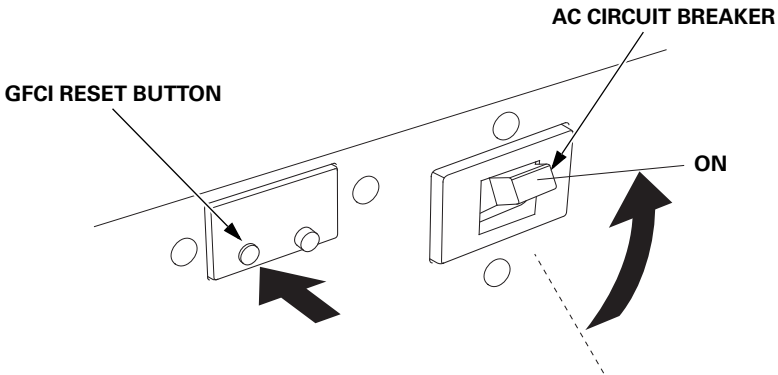

- During generator use, if the GFCI RESET button extends and the AC circuit breaker trips, this usually indicates a faulty power tool, appliance, or cord.
- If that occurs, perform operation check steps 1 through 6 to verify that the GFCI and AC circuit breaker are in proper working order. If the GFCI and AC circuit breaker do test correctly, then the fault is likely to be in the power tool, appliance, or cord. Repair or replace the faulty power tool, appliance, or cord before further use.

GFCI System ② (120V-20A Duplex Receptacle)

1. Unplug all tools and appliances from the generator.
2. Start the engine (see page 26).
3. Turn the AC circuit breaker to the ON position.
4. Turn OFF the auto throttle switch (see page 27).
5. Press the TEST button:
 - The RESET button should extend.
 - If the GFCI does not function as described, contact an authorized Honda generator dealer.

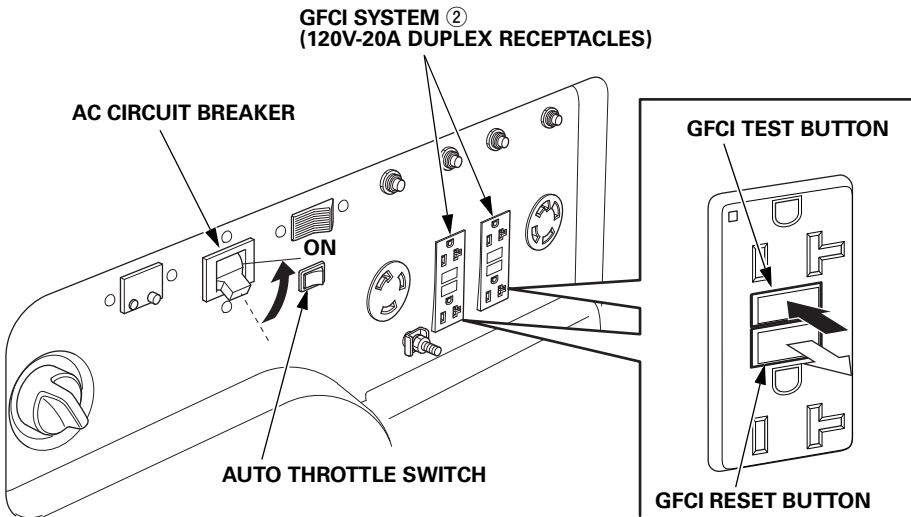

OPERATION

6. Press the RESET button:

- The RESET button should be flush with the base.
- If the RESET button is not flush with the TEST button, contact an authorized Honda generator dealer.

7. Check the GFCI LED to see if it is correctly functioning.

- The LED is lit during normal operation.
- The LED is not lit during a GFCI test.
- The LED is not lit if the GFCI is faulty. Contact an authorized Honda generator dealer.

When the RESET button extends or the GFCI LED is not lit during operation.

- Unplug all appliances from the GFCI protected receptacle.
- Press the RESET button.
 - If the GFCI cannot be reset, the GFCI is faulty. Contact an authorized Honda generator dealer.
 - If the RESET button extends, this usually indicates a faulty power tool, appliance, or cord. If that occurs, perform operation check steps 1 through 7 to verify that the GFCI is in proper working order. If the GFCI tests correctly, then the fault is likely to be in the power tool, appliance, or cord. Repair or replace the faulty power tool, appliance, or cord before further use.

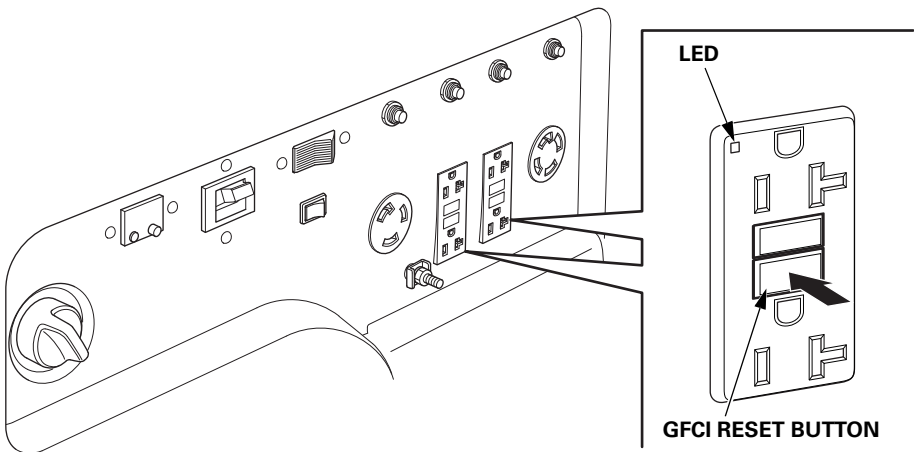

AC OPERATION

If an appliance begins to operate abnormally, becomes sluggish, or stops suddenly, turn it off immediately. Disconnect the appliance, and determine whether the problem is in the appliance or the rated load capacity of the generator has been exceeded.

NOTICE

Substantial overloading may damage the generator. Marginal overloading may shorten the service life of the generator.

1. Turn the voltage selector switch to either position.
With the voltage selector switch in the "120V/240V" position, you can use the 120V and 120V/240V receptacles simultaneously. If you are NOT using 240 volts, then select the "120V ONLY" position.

NOTICE

Disconnect or turn OFF all appliances or tools connected to the generator before changing the voltage selector switch position. The generator may be damaged if the switch position is changed with loads connected and operating.

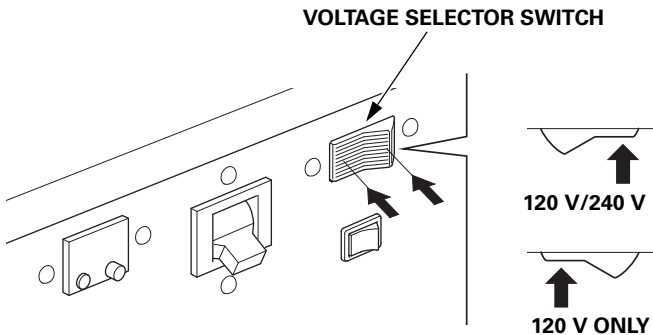

2. Start the engine (see page 26).

OPERATION

3. Switch ON the AC circuit breaker.

4. Plug in the appliance.

Most motorized appliances require more than their rated wattage for startup.

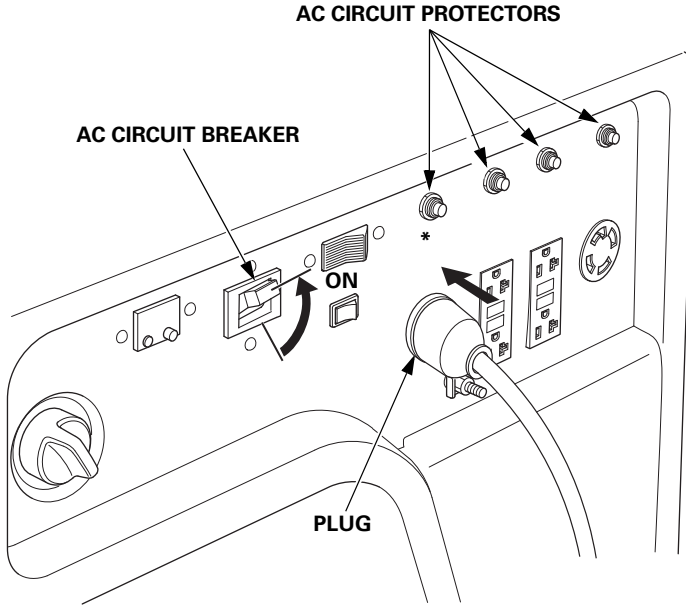

*: Except EB4000X

5. Turn on the appliance.

Do not exceed the current limit specified for any of the receptacles. If an overloaded circuit causes the AC circuit breaker or AC circuit protector to switch OFF, reduce the electrical load on the circuit, wait a few minutes and then reset the AC circuit breaker or AC circuit protector.

If the generator is overloaded and the internal circuit is overheated, current to the connected appliance(s) may shut off, even though the AC circuit breaker stays ON and the engine keeps running. Stop the engine and correct the problem. Allow the generator to cool for a few minutes, and then restart the engine (see page 26).

AC Applications

Before connecting an appliance or power cord to the generator:

- Make sure that it is in good working order. A faulty appliance or power cord can create a potential for electrical shock.
- If an appliance begins to operate abnormally, becomes sluggish, or stops suddenly, turn it off immediately. Disconnect the appliance, and determine whether the problem is the appliance or the rated load capacity of the generator has been exceeded.

Most appliance motors require more than their rated wattage for startup.

Make sure the electrical rating of the tool or appliance does not exceed the maximum power rating of the generator.

Maximum power is:

EB4000X: 4.0 kVA

EB5000X: 5.0 kVA

EB6500X: 6.5 kVA

For continuous operation, do not exceed the rated power.

Rated power is:

EB4000X: 3.6 kVA

EB5000X: 4.5 kVA

EB6500X: 5.5 kVA

In either case, the total power requirements (VA) of all appliances connected must be considered. Appliance and power tool manufacturers usually list rating information near the model number or serial number.

NOTICE

Substantial overloading will open the circuit breaker. Slightly overloading the generator may not switch the circuit breaker OFF, but will shorten the service life of the generator.

OPERATION

AC Receptacle Selection

The control panel, shown below, has a voltage selector switch and four receptacles. Receptacle 4, the 240-volt receptacle, has two powered terminals, 4A and 4B.

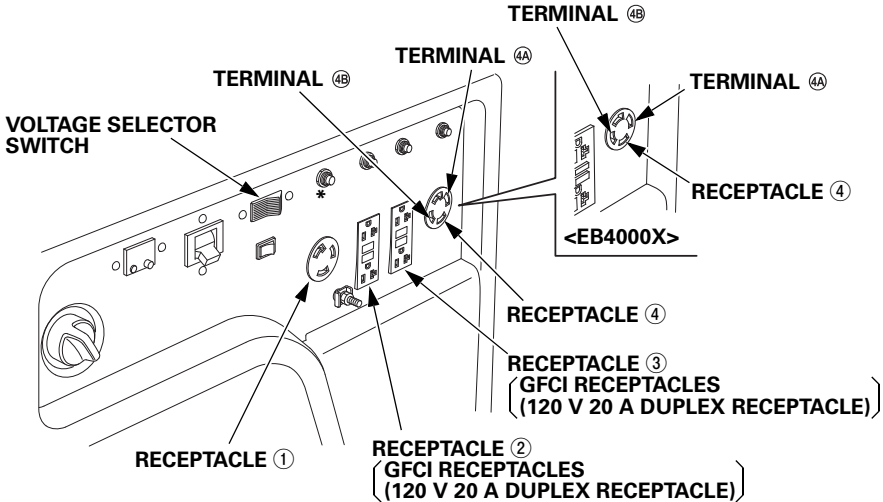

*: Except EB4000X

Power Producing Circuits

This generator is equipped with two power generating circuits. When the voltage selector switch is in the 120V/240V position, each of the two power producing circuits supplies power to specific receptacles.

When the voltage selector switch is in the 120V ONLY position, the power producing circuits operate in parallel, sharing the total load connected to terminal 4A and receptacles 1, 2, and 3.

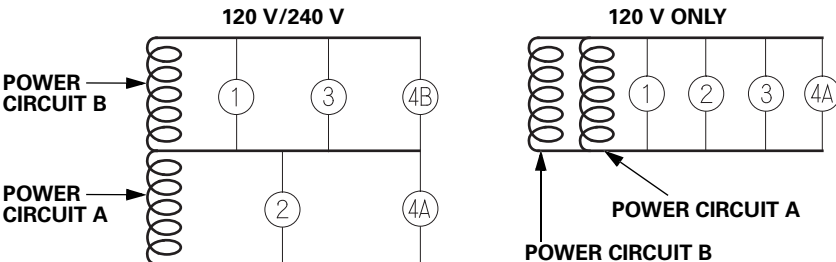

Voltage Selector Switch

NOTICE

Disconnect or turn OFF all appliances or tools connected to the generator before changing the voltage selector switch position. The generator may be damaged if the switch position is changed with loads connected and operating.

The power available to each receptacle depends on the position of the voltage selector switch.

Switch Position	Receptacle	Available Power		
		EB4000X	EB5000X	EB6500X
120V ONLY	①	30A at 120V	30A at 120V	30A at 120V
	②	20A at 120V	20A at 120V	20A at 120V
	③	20A at 120V	20A at 120V	20A at 120V
	④A	20A at 120V	30A at 120V	30A at 120V
	④B	None	None	None
120V/240V	①	15.0A at 120V	18.8A at 120V	22.9A at 120V
	②	15.0A at 120V	18.8A at 120V	20A at 120V
	③	15.0A at 120V	18.8A at 120V	20A at 120V
	④A-④B	15.0A at 240V	18.8A at 240V	22.9A at 240V

120V ONLY Position

When the voltage selector switch is in the 120V ONLY position, you do not need to spread the load over the receptacles. You must, however, make sure the load on any receptacle does not exceed its available power shown in the table above and the total load does not exceed the total current available.

Total Current Available:

30.0 A (EB4000X)

37.5 A (EB5000X)

45.8 A (EB6500X)

OPERATION

120V/240V Position

When the voltage selector switch is in the 120V/240V position, you must balance the load. Divide the load between the two sets of receptacles shown below. Balancing is necessary because each set of receptacles is powered by only one power producing circuit that can produce a maximum of amps(*).

*:

15.0 A (EB4000X)

18.8 A (EB5000X)

22.9 A (EB6500X)

Set of Receptacles	Total Current Available			Power Producing Circuit
	EB4000X	EB5000X	EB6500X	
① + ③ + ④B	15.0A	18.8A	22.9A	B
② + ④A	15.0A	18.8A	22.9A	A

AUTO THROTTLE[®] SYSTEM

With the switch in the ON position, engine speed is automatically reduced when ALL loads are turned OFF or disconnected. When appliances are turned ON or reconnected, the engine returns to rated speed. In the OFF position, the Auto Throttle system does not operate. The Auto Throttle system will not respond to electrical loads of less than 1 ampere or intermittent loads such as a staple gun. Turn the Auto Throttle switch to the OFF position to operate loads of less than 1 amp.

Appliances with large start-up power demands may not allow the engine to reach normal operating rpm when they are connected to the generator. Push the Auto Throttle switch to the OFF position and connect the appliance to the generator. If the engine still will not reach normal operating speed, check that the appliance does not exceed the rated load capacity of the generator.

To avoid extended warm-up periods, keep the switch OFF until the engine reaches operating temperature.

The Auto Throttle system is not effective for use with appliances that require only momentary power. If the tool or appliance will be turned ON and OFF quickly, the Auto Throttle switch should be in the OFF position.

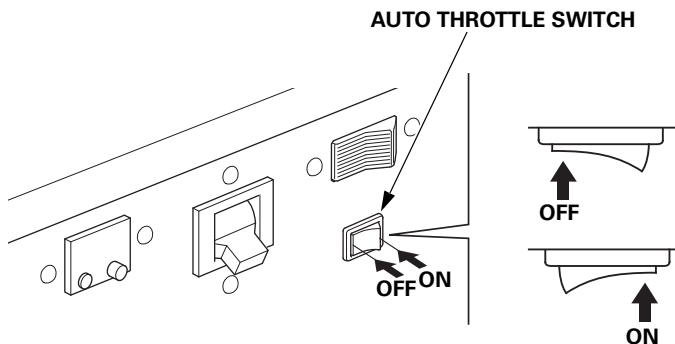

OPERATION

STANDBY POWER

Connections to a Building's Electrical System

Connections for standby power to a building's electrical system must be made by a qualified electrician. The connection must isolate the generator power from utility power, and must comply with all applicable laws and electrical codes.

⚠ WARNING

Improper connections to a building's electrical system can allow current from the generator to backfeed into the utility lines.

Such backfeed may electrocute utility company workers or others who contact the lines during a power outage, and the generator may explode, burn, or cause fires when utility power is restored.

Consult the utility company or a qualified electrician prior to making any power connections.

In some areas, generators are required by law to be registered with local utility companies. Check local regulations for proper registration and use procedures.

System Ground

This generator has a system ground that connects generator frame components to ground terminals in the AC output receptacles. The system ground is connected to the AC neutral wire.

Special Requirements

There may be Federal or State Occupational Safety and Health Administration (OSHA) regulations, local codes, or ordinances that apply to the intended use of the generator. Please consult a qualified electrician, electrical inspector, or the local agency having jurisdiction.

- In some areas, generators are required to be registered with local utility companies.
- If the generator is used at a construction site, there may be additional regulations that must be observed.

SERVICING YOUR GENERATOR

THE IMPORTANCE OF MAINTENANCE

Good maintenance is essential for safe, economical, and trouble free operation. It will also help reduce air pollution.

To help you properly care for your generator, the following pages include a maintenance schedule, routine inspection procedures, and simple maintenance procedures using basic hand tools. Other service tasks that are more difficult or require special tools are best handled by professionals and are normally performed by a Honda technician or other qualified mechanic.

The maintenance schedule applies to normal operating conditions. If you operate your generator under unusual conditions, such as sustained high-load or high-temperature operation, or use it in dusty conditions, consult your servicing dealer for recommendations applicable to your individual needs and use.

WARNING

Failure to properly maintain this generator, or failing to correct a problem before operation, could result in a significant malfunction.

Some malfunctions can seriously hurt or kill you.

Always follow the inspection and maintenance recommendations and schedules in this owner's manual.

Remember that an authorized Honda servicing dealer knows your generator best and is fully equipped to maintain and repair it.

To ensure the best quality and reliability, use only new, Honda Genuine parts or their equivalents for repair and replacement.

Maintenance, replacement, or repair of the emission control devices and systems may be performed by any engine repair establishment or individual, using parts that are "certified" to EPA standards.

MAINTENANCE SAFETY

Some of the most important safety precautions follow. However, we cannot warn you of every conceivable hazard that can arise in performing maintenance. Only you can decide whether or not you should perform a given task.

WARNING

Improper maintenance can cause an unsafe condition.

Failure to properly follow maintenance instructions and precautions can cause you to be seriously hurt or killed.

Always follow the procedures and precautions in this owner's manual.

Safety Precautions

Make sure the engine is off before you begin any maintenance or repairs. This will eliminate several potential hazards:

- **Carbon monoxide poisoning from engine exhaust.**
Operate outside away from open windows or doors.
- **Burns from hot parts.**
Let the engine and exhaust system cool before touching.
- **Injury from moving parts.**
Do not run the engine unless instructed to do so.
- Read the instructions before you begin, and make sure you have the tools and skills required.
- To reduce the possibility of fire or explosion, be careful when working around gasoline. Use only a non-flammable solvent, not gasoline, to clean parts. Keep cigarettes, sparks, and flames away from all fuel-related parts.

SERVICING YOUR GENERATOR

MAINTENANCE SCHEDULE

REGULAR SERVICE PERIOD (3) Perform at every indicated month or operating hour interval, whichever comes first.		Each use	First month or 20 Hrs.	Every 3 months or 50 Hrs.	Every 6 months or 100 Hrs.	Every year or 300 Hrs.	Page
ITEM							
Engine oil	Check level	o					49
	Change		o		o		50
Air cleaner	Check	o					52
	Clean			o (1)			54
GFCI operation	Check	o					30
Sediment cup	Clean				o		58
Spark plug	Check-adjust				o		55
	Replace					o	
Spark arrester	Clean				o		57
Valve clearance	Check-adjust					o (2)	—
Combustion chamber	Clean	After every 1,000 Hrs. (2)					—
Fuel tank and filter	Clean				o (2)		—
Fuel tube	Check	Every 2 years (Replace if necessary) (2)					—
Canister	Check	Every 2 years (2)					—
Purge tube	Check	Every 2 years (2)					—
Charge tube	Check	Every 2 years (2)					—

(1) Service more frequently when used in dusty areas.

(2) These items should be serviced by your servicing dealer, unless you have the proper tools and are mechanically proficient. Refer to the Honda shop manual for service procedures. See "Honda Publications" on page 76 for ordering information.

(3) For commercial use, log hours of operation to determine proper maintenance intervals.

Failure to follow this maintenance schedule could result in non-warrantable failures.

REFUELING

With the engine stopped, check the fuel gauge. Refill the fuel tank if the fuel level is low.

⚠ WARNING

Gasoline is highly flammable and explosive.

You can be burned or seriously injured when handling fuel.

- Stop the engine and keep heat, sparks, and flame away when refueling.
- Handle fuel only outdoors.
- Wipe up spills immediately.

NOTICE

Fuel can damage paint and plastic. Be careful not to spill fuel when filling your fuel tank. Damage caused by spilled fuel is not covered under warranty.

Refuel in a well-ventilated area before starting the engine. If the engine has been running, allow it to cool. Refuel carefully to avoid spilling fuel.

Do not fill above the upper level mark (see page 48) or fuel may flow into the charcoal canister causing fuel spillage. This overflow may also prevent the fuel tank from venting properly.

Never refuel the engine inside a building where gasoline fumes may reach flames or sparks. Keep gasoline away from appliance pilot lights, barbecues, electric appliances, power tools, etc.

Spilled fuel is not only a fire hazard, it causes environmental damage. Wipe up spills immediately.

SERVICING YOUR GENERATOR

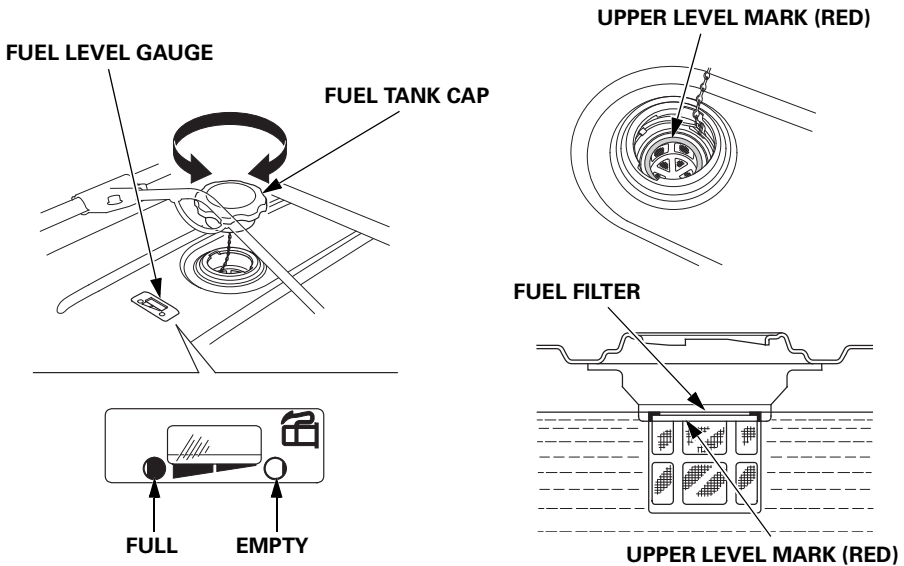

After refueling, reinstall the fuel tank cap securely.

FUEL RECOMMENDATIONS

This engine is certified to operate on regular unleaded gasoline with a pump octane rating of 86 or higher.

Never use stale or contaminated gasoline or an oil/gasoline mixture. Avoid getting dirt or water in the fuel tank.

You may use regular unleaded gasoline containing no more than 10% ethanol (E10) or 5% methanol by volume. In addition, methanol must contain cosolvents and corrosion inhibitors.

Use of fuels with content of ethanol or methanol greater than shown above may cause starting and/or performance problems. It may also damage metal, rubber, and plastic parts of the fuel system.

Engine damage or performance problems that result from using a fuel with percentages of ethanol or methanol greater than shown above are not covered under warranty.

If your equipment will be used on an infrequent or intermittent basis, please refer to the fuel section of the *STORAGE* chapter (see page 59) for additional information regarding fuel deterioration.

SERVICING YOUR GENERATOR

ENGINE OIL LEVEL CHECK

Check the engine oil level with the engine stopped and in a level position.

1. Remove the oil filler cap/dipstick and wipe it clean.
2. Insert and remove the dipstick without screwing it into the filler neck. Check the oil level shown on the dipstick.
3. If the oil level is low, fill to the upper limit mark on the dipstick with the recommended oil (see page 51).
4. Reinstall the oil filler cap/dipstick securely.

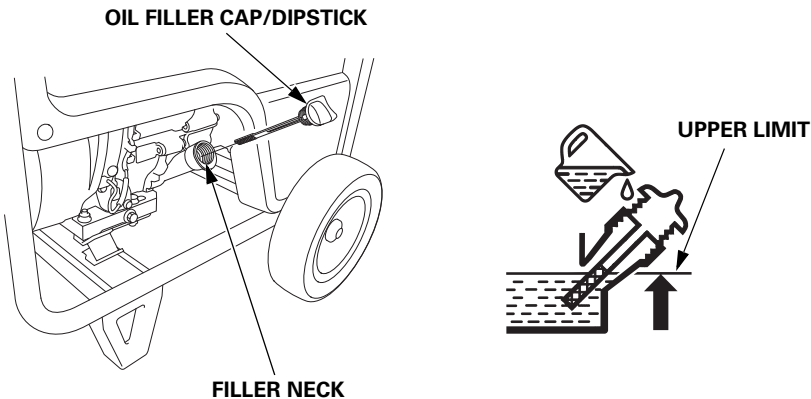

The Oil Alert system will automatically stop the engine before the oil level falls below safe limits. However, to avoid the inconvenience of an unexpected shutdown, check the oil level regularly.

SERVICING YOUR GENERATOR

ENGINE OIL CHANGE

Drain the oil while the engine is warm to assure rapid and complete draining.

1. Place a suitable container below the engine to catch the used oil, and then remove the oil filler cap/dipstick, 12x15 mm drain plug, and sealing washer.
2. Allow the used oil to drain completely, and then reinstall the 12x15 mm drain plug and a new sealing washer. Tighten the plug securely.
3. With the generator in a level position, fill to the upper limit mark on the dipstick with the recommended oil (see page 51).

Maximum oil capacity: 1.2 US qt (1.1 L)

4. Reinstall the oil filler cap/dipstick securely.

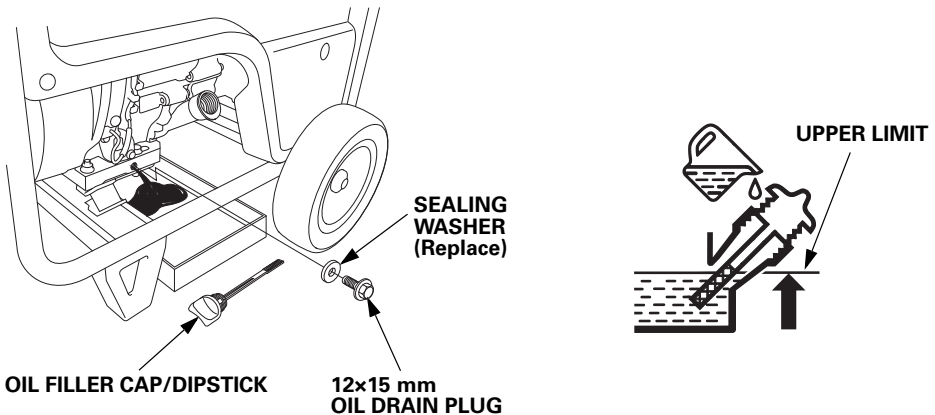

Wash your hands with soap and water after handling used oil.

NOTICE

Improper disposal of engine oil can be harmful to the environment. If you change your own oil, please dispose of it properly. Put it in a sealed container, and take it to a recycling center. Do not discard it in a trash bin, dump it on the ground, or pour it down a drain.

SERVICING YOUR GENERATOR

ENGINE OIL RECOMMENDATIONS

Oil is a major factor affecting performance and service life. Use 4-stroke automotive detergent oil.

SAE 10W-30 is recommended for general use. Other viscosities shown in the chart may be used when the average temperature in your area is within the recommended range.

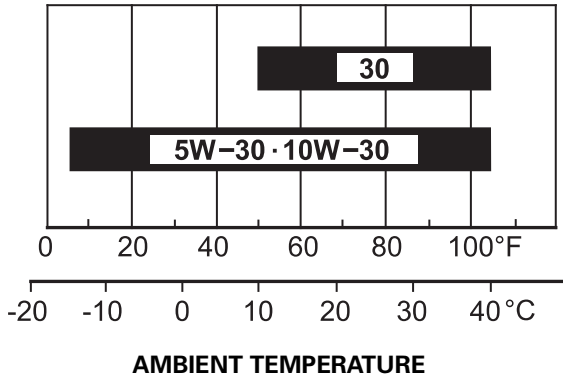

The SAE oil viscosity and service category are in the API label on the oil container. Honda recommends that you use API service category SJ or later (or equivalent) oil.

SERVICING YOUR GENERATOR

AIR CLEANER SERVICE

1. Unsnap the air cleaner cover clips and open the air cleaner cover.
2. Free the hooks from the setting pins on the air cleaner case and remove the air cleaner cover to the right side of the frame pipe, taking care not to damage the air cleaner cover.
3. Remove the air cleaner element from the air cleaner case.
4. Check the air cleaner element to be sure it is clean and in good condition.
If the air cleaner element is dirty, clean it as described on page 54.
Replace the air cleaner element if it is damaged.

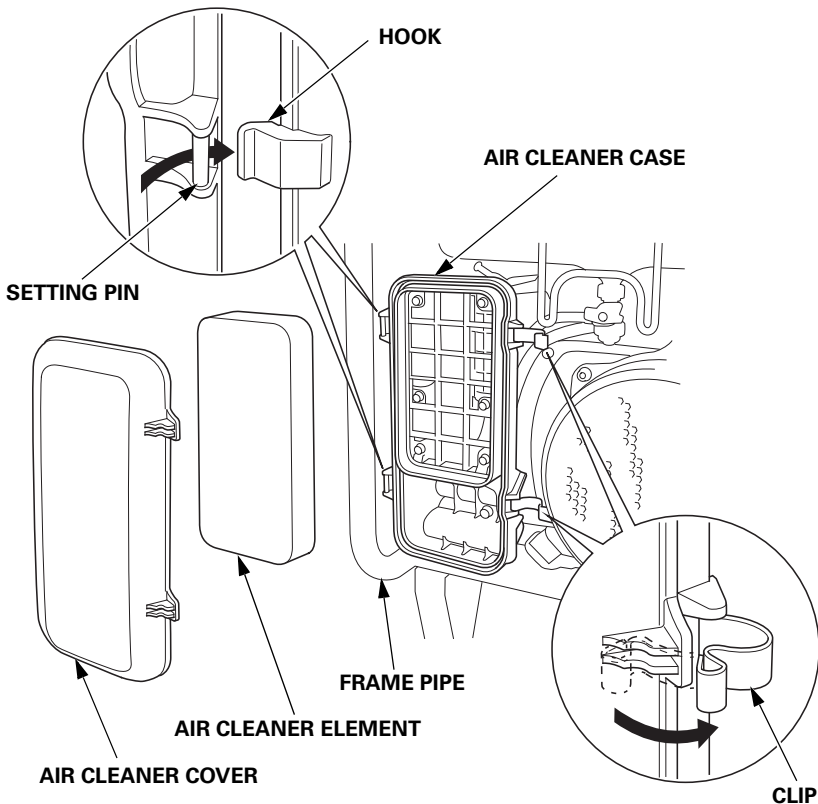

SERVICING YOUR GENERATOR

5. Reinstall the air cleaner element in the air cleaner case.
6. Set the hooks of the air cleaner cover to the setting pins securely, and then push the air cleaner cover to lock the clips. Be sure that the cover is set securely. There must be no clearance between the air cleaner cover and air cleaner case.

NOTICE

Operating the engine without an air filter or with a damaged air filter will allow dirt to enter the engine, causing rapid engine wear. This type of damage is not covered by the Distributor's Limited Warranty.

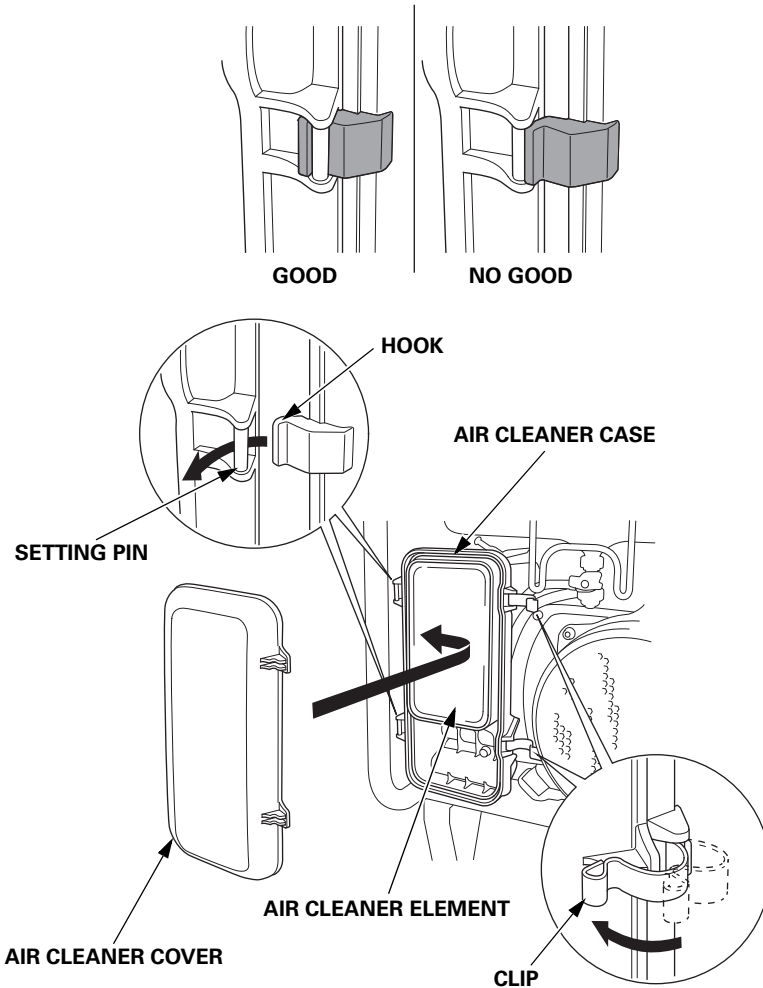

SERVICING YOUR GENERATOR

AIR CLEANER ELEMENT CLEANING

A dirty air cleaner element will restrict air flow to the carburetor, reducing engine performance. If you operate the generator in very dusty areas, clean the air cleaner element more frequently than specified in the Maintenance Schedule.

1. Clean the foam air filter in warm soapy water, rinse, and allow to dry thoroughly, or clean in non-flammable solvent and allow to dry.
2. Dip the foam air filter in clean engine oil, and then squeeze out all excess oil. The engine will smoke when started if too much oil is left in the filter.

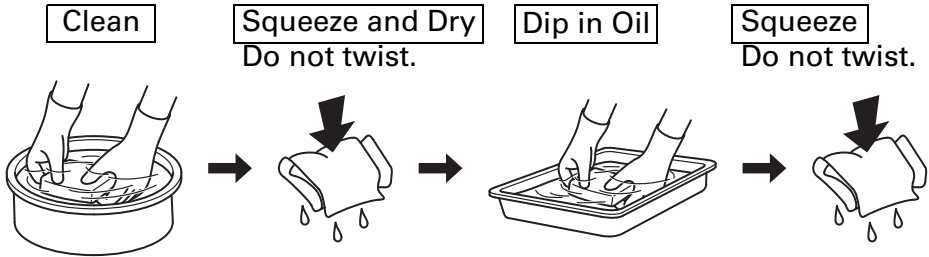

3. Wipe dirt from the air cleaner housing and cover using a moist rag. Be careful to prevent dirt from entering the air duct that leads to the carburetor.

SERVICING YOUR GENERATOR

SPARK PLUG SERVICE

In order to service the spark plug, you will need a spark plug wrench (commercially available).

Recommended spark plugs: BPR5ES (NGK)
W16EPR-U (DENSO)

To ensure proper engine operation, the spark plug must be properly gapped and free of deposits.

NOTICE

An incorrect spark plug can cause engine damage.

If the engine is hot, allow it to cool before servicing the spark plug.

1. Disconnect the spark plug cap, and remove any dirt from around the spark plug area.
2. Remove the spark plug with a spark plug wrench.

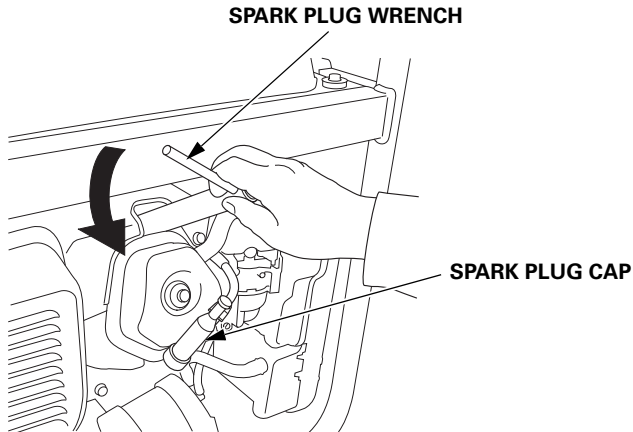

SERVICING YOUR GENERATOR

3. Visually inspect the spark plug. Replace it if the electrodes are worn or if the insulator is cracked, chipped, or fouled.
4. Measure the spark plug electrode gap with a wire-type feeler gauge. Correct the gap, if necessary, by carefully bending the side electrode. The gap should be:
0.028–0.031 in (0.7–0.8 mm)

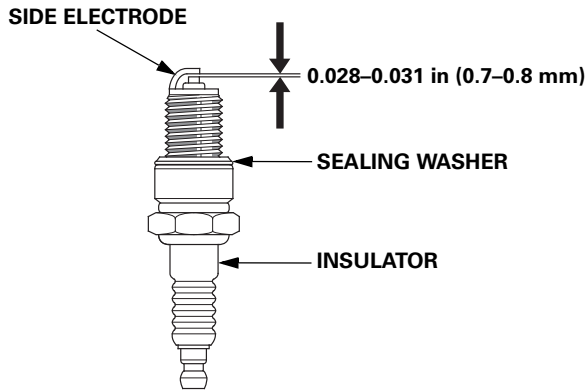

5. Check that the spark plug sealing washer is in good condition, and thread the spark plug in by hand to prevent cross-threading.
6. After the spark plug is seated, tighten with a spark plug wrench to compress the washer.

If installing a new spark plug, tighten 1/2 turn after the spark plug seats to compress the washer. If reinstalling a used spark plug, tighten 1/8–1/4 turn after the spark plug seats to compress the washer.

NOTICE

A loose spark plug can overheat and damage the engine. Overtightening the spark plug can damage the threads in the cylinder head.

7. Attach the spark plug cap.

SERVICING YOUR GENERATOR

SPARK ARRESTER SERVICE

The spark arrester must be serviced every 100 hours to keep it functioning as designed.

If the engine has been running, the muffler will be very hot. Allow the muffler to cool before servicing the spark arrester.

Clean the spark arrester as follows:

1. Remove the two 5 mm screws, and remove the spark arrester.

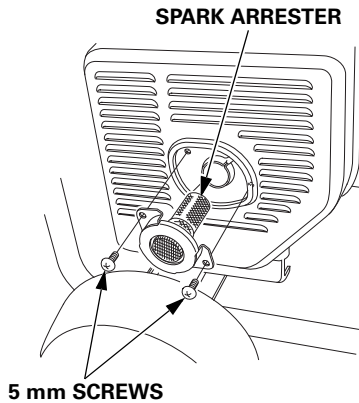

2. Use a brush to remove carbon deposits from the spark arrester screen.

Be careful to avoid damaging the screen.

The spark arrester must be free of breaks and tears. Replace the spark arrester if it is damaged.

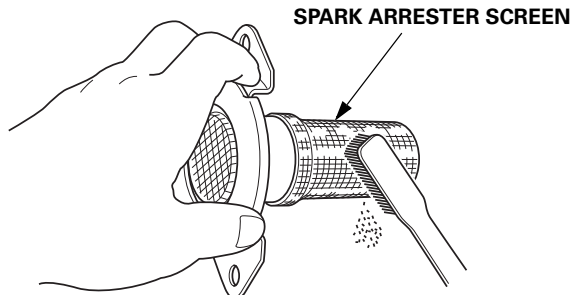

3. Install the spark arrester in the reverse order of removal.

SERVICING YOUR GENERATOR

SEDIMENT CUP CLEANING

The sediment cup prevents dirt or water that may be in the fuel tank from entering the carburetor. If the engine has not been run for a long time, the sediment cup should be cleaned.

1. Turn the engine switch to the OFF position.

⚠ WARNING

Gasoline is highly flammable and explosive.

You can be burned or seriously injured when handling fuel.

- Stop the engine and keep heat, sparks, and flame away when refueling.
- Handle fuel only outdoors.
- Wipe up spills immediately.

2. Turn the fuel valve lever to the OFF position; then remove the sediment cup and the O-ring. Discard the O-ring.
3. Clean the sediment cup in nonflammable solvent, and dry it thoroughly.
4. Install the sediment cup and a new O-ring, and tighten the sediment cup securely.
5. Turn the fuel valve lever to the ON position and check for leaks.

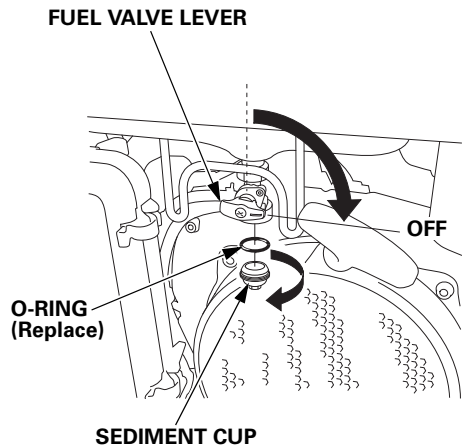

STORAGE

STORAGE PREPARATION

Proper storage preparation is essential for keeping your generator trouble-free and looking good. The following steps will help to keep rust and corrosion from impairing your generator's function and appearance, and will make the engine easier to start when you use the generator again.

Cleaning

Wipe the generator with a moist cloth. After the generator has dried, touch up any damaged paint, and coat other areas that may rust with a light film of oil.

Fuel

NOTICE

Depending on the region where you operate your equipment, fuel formulations may deteriorate and oxidize rapidly. Fuel deterioration and oxidation can occur in as little as 30 days and may cause damage to the carburetor and/or fuel system. Please check with your servicing dealer for local storage recommendations.

Gasoline will oxidize and deteriorate in storage. Old gasoline will cause hard starting, and it leaves gum deposits that clog the fuel system. If the gasoline in your generator deteriorates during storage, you may need to have the carburetor and other fuel system components serviced or replaced.

The length of time that gasoline can be left in your fuel tank and carburetor without causing functional problems will vary with such factors as gasoline blend, your storage temperatures, and whether the fuel tank is partially or completely filled. The air in a partially filled fuel tank promotes fuel deterioration. Very warm storage temperatures accelerate fuel deterioration. Fuel deterioration problems may occur within a few months, or even less if the gasoline was not fresh when you filled the fuel tank.

The *Distributor's Limited Warranty* does not cover fuel system damage or engine performance problems resulting from neglected storage preparation.

You can extend fuel storage life by adding a gasoline stabilizer that is formulated for that purpose, or you can avoid fuel deterioration problems by draining the carburetor, sediment cup, and/or fuel tank.

STORAGE

Service according to the table below:

STORAGE TIME	RECOMMENDED SERVICE PROCEDURE TO PREVENT HARD STARTING
Less than 1 month	No preparation required
1 to 2 months	Fill with fresh gasoline and add gasoline stabilizer *.
2 months to 1 year	Fill with fresh gasoline and add gasoline stabilizer *. Drain the carburetor float bowl (see page 61). Drain the fuel sediment cup (see page 58).
1 year or more	Fill with fresh gasoline and add gasoline stabilizer *. Drain the carburetor float bowl (see page 61). Drain the fuel sediment cup (see page 58). Remove the spark plug. Put a teaspoon of engine oil into the cylinder. Turn the engine slowly with the pull rope to distribute the oil. Reinstall the spark plug. Change the engine oil (see page 50). After removal from storage, drain the stored gasoline into a suitable container, and fill with fresh gasoline before starting.
* Use gasoline stabilizers that are formulated to extend storage life. Follow the manufacturer's instructions for use. Contact your authorized Honda generator dealer for stabilizer recommendations.	

Draining the Fuel Tank and Carburetor

⚠ WARNING

Gasoline is highly flammable and explosive.

You can be burned or seriously injured when handling fuel.

- Stop the engine and keep heat, sparks, and flame away when refueling.
- Handle fuel only outdoors.
- Wipe up spills immediately.

1. Turn the fuel valve lever to the OFF position.
2. Place a suitable gasoline container below the carburetor, and use a funnel to avoid spilling fuel.
3. Loosen the carburetor drain screw and drain the gasoline from the carburetor.

CARBURETOR DRAIN SCREW

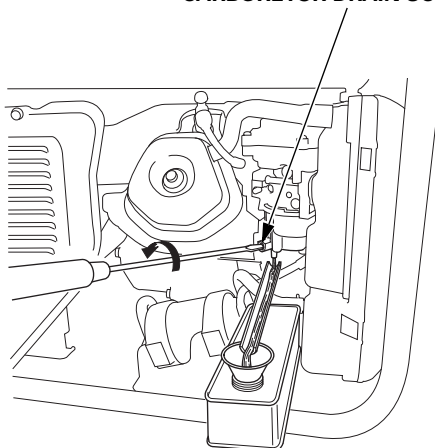

STORAGE

4. After all the gasoline has drained into the container, tighten the carburetor drain screw securely.
5. Place a suitable gasoline container below the sediment cup, and use a funnel to avoid spilling gasoline.
6. Remove the sediment cup (see page 58), and then turn the fuel valve lever to the ON position and drain the fuel from the fuel tank.
7. After all the fuel tank has drained into the container, install the sediment cup and a new O-ring.
8. Turn the fuel valve lever to the OFF position.

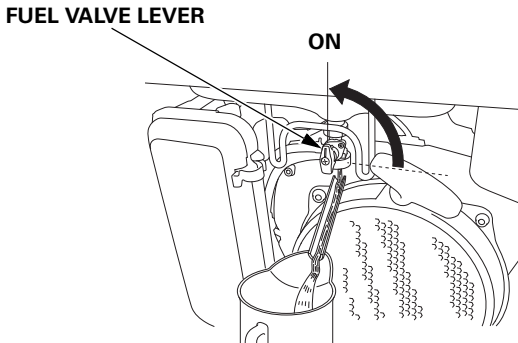

Engine Oil

Change the engine oil (see page 50).

Engine Cylinder

1. Remove the spark plug, and pour a teaspoon (5 cc) of clean engine oil into the cylinder. Crank the engine several revolutions to distribute the oil, then reinstall the spark plug.
2. Slowly pull the starter grip until resistance is felt. At this point, the piston is coming up on its compression stroke, and both the intake and exhaust valves are closed. Storing the engine in this position will help to protect it from internal corrosion.

STORAGE PRECAUTIONS

If your generator will be stored with gasoline in the fuel tank and carburetor, it is important to reduce the hazard of gasoline vapor ignition.

Select a well ventilated storage area away from any appliance that operates with a flame, such as a furnace, water heater, or clothes dryer. Also avoid any area with a spark-producing electric motor, or where power tools are operated.

If possible, avoid storage areas with high humidity, because that promotes rust and corrosion.

Unless all fuel has been drained from the fuel tank, leave the engine switch in the OFF position, and the fuel valve lever in the OFF position (see page 29) to reduce the possibility of leakage.

Place the generator on a level surface. Tilting or laying it on its side can cause fuel or oil leakage.

With the engine and exhaust system cool, cover the generator to keep out dust. A hot engine and exhaust system can ignite or melt some materials.

Do not use sheet plastic as a dust cover. A nonporous cover will trap moisture around the generator, promoting rust and corrosion.

REMOVAL FROM STORAGE

Check your generator as described in the *BEFORE OPERATION* chapter of this manual (see page 23).

If the generator was stored for 1 year or longer, drain the fuel tank (see page 61) and refuel with fresh gasoline. If you keep a container of gasoline for refueling, be sure that it contains only fresh gasoline. Gasoline oxidizes and deteriorates over time, causing hard starting.

If the cylinder was coated with oil during storage preparation, the engine may smoke briefly at startup. This is normal.

TRANSPORTING

NOTICE

Do not lay the generator on its side when moving, storing, or operating it. Oil or fuel may leak and damage the engine or your property.

If the generator has been running, allow the engine to cool for at least 15 minutes before loading the generator on the transport vehicle. A hot engine and exhaust system can burn you and can ignite some materials.

Keep the generator level when transporting to reduce the possibility of fuel leakage. Move the fuel valve lever to the OFF position. Do not use the generator while it is being transported.

When using ropes or tie-down straps to secure the generator for transportation, be sure to only use the frame bars as attachment points. Do not fasten ropes or straps to any portions of the generator body or handle bar.

To lift the generator

Lift the generator by the lifting hanger. Do not try to lift the generator by any other part.

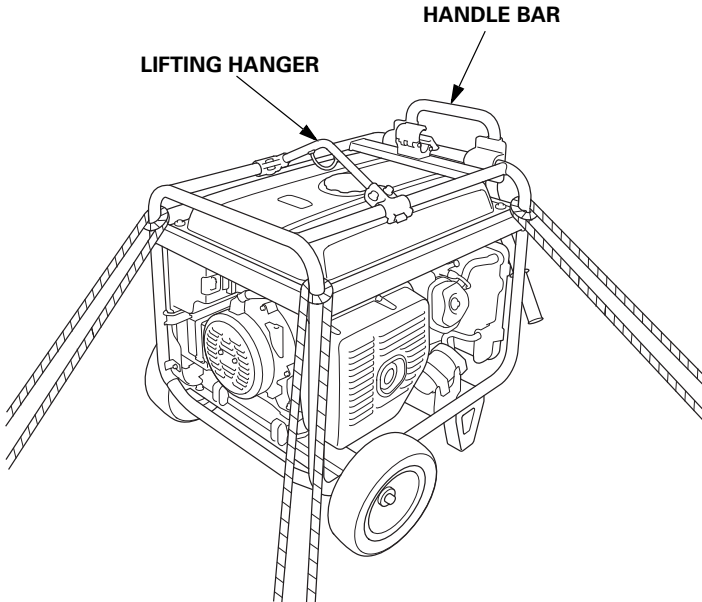

TAKING CARE OF UNEXPECTED PROBLEMS

ENGINE WILL NOT START

Possible Cause	Correction
Fuel valve lever OFF.	Turn lever ON (see page 26).
Engine switch OFF.	Turn engine switch to ON (see page 27).
Out of fuel.	Refuel (see page 47).
Bad fuel; generator stored without treating or draining gasoline, or refueled with bad gasoline.	Drain fuel tank and carburetor (see page 61). Refuel with fresh gasoline (see page 47).
Low oil level caused Oil Alert to stop engine.	Add oil (see page 49). Turn engine switch to OFF and then restart the engine.
Spark plug faulty, fouled, or improperly gapped.	Gap or replace spark plug (see page 56).
Spark plug wet with fuel (flooded engine).	Dry and reinstall spark plug.
Fuel filter restricted, carburetor malfunction, ignition malfunction, valves stuck, etc.	Take the generator to an authorized Honda servicing dealer, or refer to the shop manual.

TAKING CARE OF UNEXPECTED PROBLEMS

ENGINE LACKS POWER

Possible Cause	Correction
Air filter restricted.	Clean or replace air filter (see pages 52, 53, 54).
Bad fuel; generator stored without treating or draining gasoline, or refueled with bad gasoline.	Drain fuel tank and carburetor (see page 61). Refuel with fresh gasoline (see page 47).
Fuel filter restricted, carburetor malfunction, ignition malfunction, valves stuck, etc.	Take the generator to an authorized Honda servicing dealer, or refer to the shop manual.

TAKING CARE OF UNEXPECTED PROBLEMS

NO POWER AT THE AC RECEPTACLES

Possible Cause	Correction
AC circuit breaker left in the OFF position after starting.	Check AC load and reset AC circuit breaker (see page 36).
GFCI system activated.	<ul style="list-style-type: none">• GFCI system ① : Test GFCI and reset AC circuit breaker (see pages 31, 32).• GFCI system ② : Test GFCI and press the RESET button (see pages 33, 34).• Replace or repair power tool or appliance.
AC circuit protector tripped.	Check AC load and reset circuit protector (see page 15).
Faulty power tool or appliance.	Replace or repair power tool or appliance. Stop and restart the engine.
Internal circuit overheated.	Stop the engine. Reduce the electrical load. Wait a few minutes for the internal circuit to cool down. Restart the engine.
Faulty generator.	Take the generator to an authorized Honda servicing dealer, or refer to the shop manual.

TECHNICAL INFORMATION

Serial Number Location

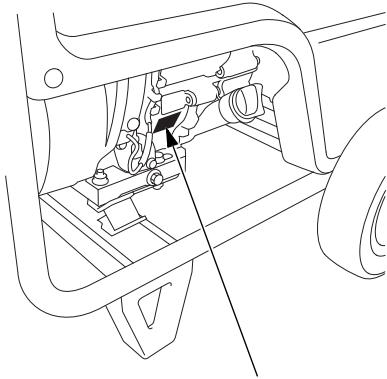

ENGINE SERIAL NUMBER

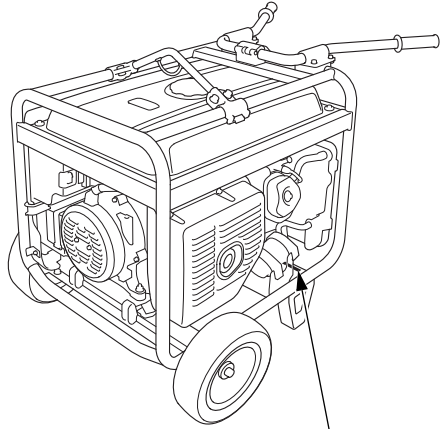

FRAME SERIAL NUMBER

Record the frame serial number and date purchased in the spaces below. You will need this information when ordering parts and when making technical or warranty inquiries.

Engine serial number: _____

Frame serial number: _____

Date purchased: _____

Carburetor Modification for High Altitude Operation

At high altitude, the standard carburetor air-fuel mixture will be too rich. Performance will decrease, and fuel consumption will increase. A very rich mixture will also foul the spark plug and cause hard starting. Operation at an altitude that differs from that at which this engine was certified, for extended periods of time, may increase emissions.

High altitude performance can be improved by specific modifications to the carburetor. If you always operate your generator at altitudes above 5,000 feet (1,500 meters), have your authorized Honda servicing dealer perform this carburetor modification. This engine, when operated at high altitude with the carburetor modifications for high altitude use, will meet each emission standard throughout its useful life.

Even with carburetor modification, engine horsepower will decrease about 3.5% for each 1,000-foot (300-meter) increase in altitude. The effect of altitude on horsepower will be greater than this if no carburetor modification is made.

NOTICE

When the carburetor has been modified for high altitude operation, the air/fuel mixture will be too lean for low altitude use. Operation at altitudes below 5,000 feet (1,500 meters) with a modified carburetor may cause the engine to overheat and result in serious engine damage. For use at low altitudes, have your servicing dealer return the carburetor to original factory specifications.

TECHNICAL INFORMATION

Emission Control System Information

Source of Emissions

The combustion process produces carbon monoxide, oxides of nitrogen, and hydrocarbons. Control of hydrocarbons and oxides of nitrogen is very important because, under certain conditions, they react to form photochemical smog when subjected to sunlight. Carbon monoxide does not react in the same way, but it is toxic.

Honda utilizes appropriate air/fuel ratios and other emissions control systems to reduce the emissions of carbon monoxide, oxides of nitrogen, and hydrocarbons.

Additionally, Honda fuel systems utilize components and control technologies to reduce evaporative emissions.

The U.S. and California Clean Air Acts

EPA and California regulations require all manufacturers to furnish written instructions describing the operation and maintenance of emission control systems.

The following instructions and procedures must be followed in order to keep the Honda engine emissions within the emission standards.

Tampering and Altering

NOTICE

Tampering is a violation of Federal and California law.

Tampering with or altering the emission control system may increase emissions beyond the legal limit. Among those acts that constitute tampering are:

- Removal or alteration of any part of intake, fuel, or exhaust systems.
- Altering or defeating the governor linkage or speed-adjusting mechanism to cause the engine to operate outside its design parameters.

Problems That May Affect Emissions

If you are aware of any of the following symptoms, have your engine inspected and repaired by your authorized Honda servicing dealer.

- Hard starting or stalling after starting.
- Rough idle.
- Misfiring or backfiring under load.
- Afterburning (backfiring).
- Black exhaust smoke or high fuel consumption.

Replacement Parts

The emission control systems on your new Honda engine were designed, built, and certified to conform with applicable emission regulations. We recommend the use of Honda Genuine parts whenever you have maintenance done. These original-design replacement parts are manufactured to the same standards as the original parts, so you can be confident of their performance. The use of replacement parts that are not of the original design and quality may impair the effectiveness of your emission control system.

A manufacturer of an aftermarket part assumes the responsibility that the part will not adversely affect emission performance. The manufacturer or rebuilder of the part must certify that use of the part will not result in a failure of the engine to comply with emission regulations.

Maintenance

Follow the *MAINTENANCE SCHEDULE* on page 46. Remember that this schedule is based on the assumption that your machine will be used for its designed purpose. Sustained high-load or high-temperature operation, or use in dusty conditions, will require more frequent service.

TECHNICAL INFORMATION

Air Index (Models sold in California)

An Air Index Information label is applied to engines certified to an emission durability time period in accordance with the requirements of the California Air Resources Board.

The bar graph is intended to provide you, our customer, the ability to compare the emissions performance of available engines. The lower the Air Index, the less pollution.

The durability description is intended to provide you with information relating to the engine's emission durability period. The descriptive term indicates the useful life period for the engine's emission control system. See your *Emission Control System Warranty* for additional information.

Descriptive Term	Applicable to Emission Durability Period
Moderate	50 hours (0–80 cc, inclusive) 125 hours (greater than 80 cc)
Intermediate	125 hours (0–80 cc, inclusive) 250 hours (greater than 80 cc)
Extended	300 hours (0–80 cc, inclusive) 500 hours (greater than 80 cc) 1,000 hours (225 cc and greater)

TECHNICAL INFORMATION

Specifications

Dimensions

Model	EB4000X	EB5000X	EB6500X
Type	AT1 type		
Description code	EBSC	EBPC	EBLC
Length	41.1 in (1,043 mm)		41.4 in (1,051 mm)
Width	27.8 in (706 mm)		
Height	30.4 in (773 mm)		
Dry mass [weight]	188.3 lbs (85.4 kg)	212.3 lbs (96.3 kg)	222.4 lbs (100.9 kg)

Engine

Model	iGX270	iGX390
Engine type	4-stroke, overhead valve, single cylinder	
Displacement [Bore×Stroke]	16.5 cu-in (270 cm ³) [3.03×2.28 in (77.0×58.0 mm)]	23.7 cu-in (389 cm ³) [3.46×2.52 in (88.0×64.0 mm)]
Compression ratio	8.5:1	8.2:1
Engine speed	3,600 rpm	
Cooling system	Forced air	
Ignition system	CDI magneto	
Oil capacity	1.2 US qt (1.1 L)	
Fuel tank capacity	6.21 US gal (23.5 L)	
Spark plug	BPR5ES (NGK) · W16EPR-U (DENSO)	

Generator

Model	EB4000X	EB5000X	EB6500X	
Type	AT1 type			
AC output	Rated voltage	120 V/240 V		
	Rated frequency	60 Hz		
	Rated current	30.0 A/15.0 A	37.5 A/18.8 A	45.8 A/22.9 A
	Rated output	3.6 kVA	4.5 kVA	5.5 kVA
	Maximum output	4.0 kVA	5.0 kVA	6.5 kVA

Tuneup

ITEM	SPECIFICATION	MAINTENANCE
Spark plug gap	0.028–0.031 in (0.7–0.8 mm)	Refer to page 56
Valve clearance (cold)	IN: 0.15±0.02 mm EX: 0.20±0.02 mm	See your authorized Honda dealer.
Other specifications	No other adjustments needed.	

Specifications may vary according to the types, and are subject to change without notice.

TECHNICAL INFORMATION

Wiring Diagram



Abbreviations

Symbol	Part name
AC O	AC Outlet
AC CB	AC Circuit Breaker
AC CP	AC Circuit Protector
AuSw	Auto Throttle Switch
CBB	Control Box Block
CT	Current Transformer
D-AVR	Digital-Automatic Voltage Regulator
D-CDI	Digital-CDI
ECU	Engine Control Unit
ESw	Engine Switch
EgB	Engine Block
EX W	Exciter Winding
FrB	Frame Block
FW	Field Winding
GeB	Generator Block
GFCI	Ground Fault Circuit Interrupter
GND	Ground
GT	Ground Terminal
J/B	Junction Box
MW	Main Winding
OLSw	Oil Level Switch
PoC	Power Coil
SP	Spark Plug
VSSw	Voltage Selector Switch

Wire color code

Bl	BLACK
Y	YELLOW
Bu	BLUE
G	GREEN
R	RED
W	WHITE
Br	BROWN
Lg	LIGHT GREEN
Gr	GRAY
Lb	LIGHT BLUE
O	ORANGE
P	PINK

Engine Switch

	IGN	E
OFF		
ON		

TECHNICAL INFORMATION

EB4000X: *1 · EB5000X, EB6500X: *2

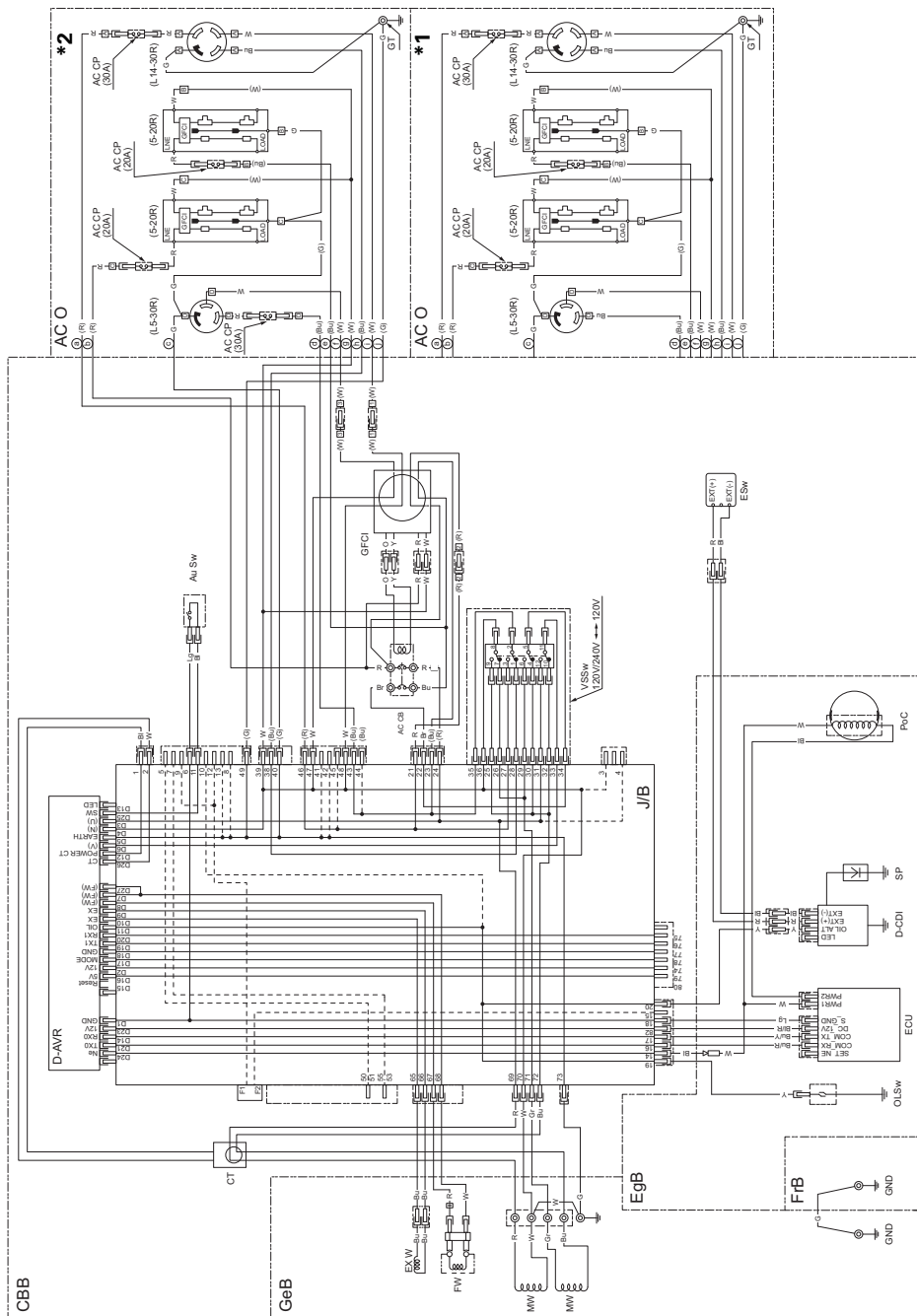

CONSUMER INFORMATION

Dealer Locator Information

To find an authorized Honda Servicing Dealer anywhere in the United States:

Visit our website:

<http://powerequipment.honda.com/dealer-locator>

Honda Publications

Shop Manual

This manual covers complete maintenance and overhaul procedures. It is intended to be used by a skilled technician.

Available through your Honda dealer or visit

<http://powerequipment.honda.com/support/shop-manuals>

Parts Catalog

This manual provides complete, illustrated parts lists. Available through your Honda dealer.

Accessories Catalog

Your authorized Honda power equipment dealer offers a wide selection of accessories (optional equipment) to make your generator even more useful.

Visit <http://powerequipment.honda.com/generators/accessories> and click on Generators and Welders to see the entire catalog of accessories.

Customer Service Information

Honda Power Equipment dealership personnel are trained professionals. They should be able to answer any question you may have. If you encounter a problem that your dealer does not solve to your satisfaction, please discuss it with the dealership's management. The Service Manager or General Manager can help. Almost all problems are solved in this way.

If you are dissatisfied with the decision made by the dealership's management, contact the Honda Power Equipment Customer Relations Office. You can write:

American Honda Motor Co., Inc.
Power Equipment Division
Customer Relations Office
4900 Marconi Drive
Alpharetta, Georgia 30005-8847

Or telephone: (770) 497-6400 8:30 am to 7:00 pm ET

When you write or call, please give us this information:

- Model and serial numbers (see page 68)
- Name of the dealer who sold the generator to you
- Name and address of the dealer who services your generator
- Date of purchase
- Your name, address, and telephone number
- A detailed description of the problem

ASSEMBLY

SAFETY

The Importance of Proper Assembly

Proper assembly is essential to operator safety and the reliability of the machine. Any error or oversight made by the person assembling and servicing a unit can easily result in faulty operation, damage to the machine, or injury to the operator.

WARNING

Improper assembly can cause an unsafe condition.

Failure to properly follow assembly procedures can lead to serious injury or death.

Follow the procedures and precautions in the assembly instructions carefully.

Some of the most important safety precautions are given below. However, we cannot warn you of every conceivable hazard that can arise in performing this assembly. Only you can decide whether or not you should perform a given task.

Important Safety Precautions

- Make sure you have a clear understanding of all basic shop safety practices and that you are wearing appropriate clothing and safety equipment. When performing this assembly, be especially careful of the following:
 - Read the instructions before you begin, and be sure you have the tools and skills required to perform the tasks safely.
- Make sure the engine is off before you begin any assembly, maintenance, or repairs. This will help eliminate several potential hazards:
 - Carbon monoxide poisoning from engine exhaust.**
Operate outside away from open windows or doors.
 - Burns from hot parts.**
Let the engine and exhaust system cool before touching.
 - Injury from moving parts.**
Do not run the engine unless the instruction tells you to do so. Even then, keep your hands, fingers, and clothing away. Do not run the engine when any protective guard or shield is removed.
- To reduce the possibility of a fire or explosion, be careful when working around gasoline or batteries. Use only a non-flammable solvent, not gasoline, to clean parts. Keep all cigarettes, sparks, and flames away from all fuel-related parts.

ASSEMBLY

ASSEMBLY

Unpacking

1. Remove the generator and loose parts box from the carton.
2. Compare the loose parts with the inventory list below.

Tools Required: 12 mm wrench (2), pliers

Loose Parts (Wheel kit, handle and hanger)

Check all loose parts against the following list. Contact your dealer if any of the loose parts shown below are not included with your generator.

Ref. No.	Description	Qty.
1	Wheel	2
2	Axle Shaft	1
3	Handle Assembly	1
4	Handle Lower Bracket	2
5	Handle Bush B	2
6	Handle Bush A	2
7	Stand	2
8	Hanger	1
9	Hanger Bracket	2
10	8×16 mm Flange bolt	20
11	20 mm Plain Washer	2
12	4.0×28 mm Split pin	2
13	8 mm Flange nut	4
14	Handle Folder Assembly	1
15	8×18 mm Flange bolt	2

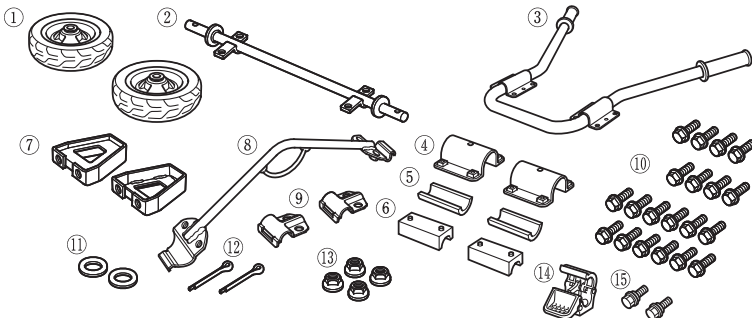

Wheel Kit Installation

1. Install the two wheels on the axle shaft using the washers and split pins.
2. Install the axle assembly on the generator using four 8×16 mm flange bolts and 8 mm flange nuts.
3. Install the two stands on the under frame using four 8×16 mm flange bolts.

TORQUE: 17–22 lbf·ft (24–29 N·m, 2.4–3.0 kgf·m)

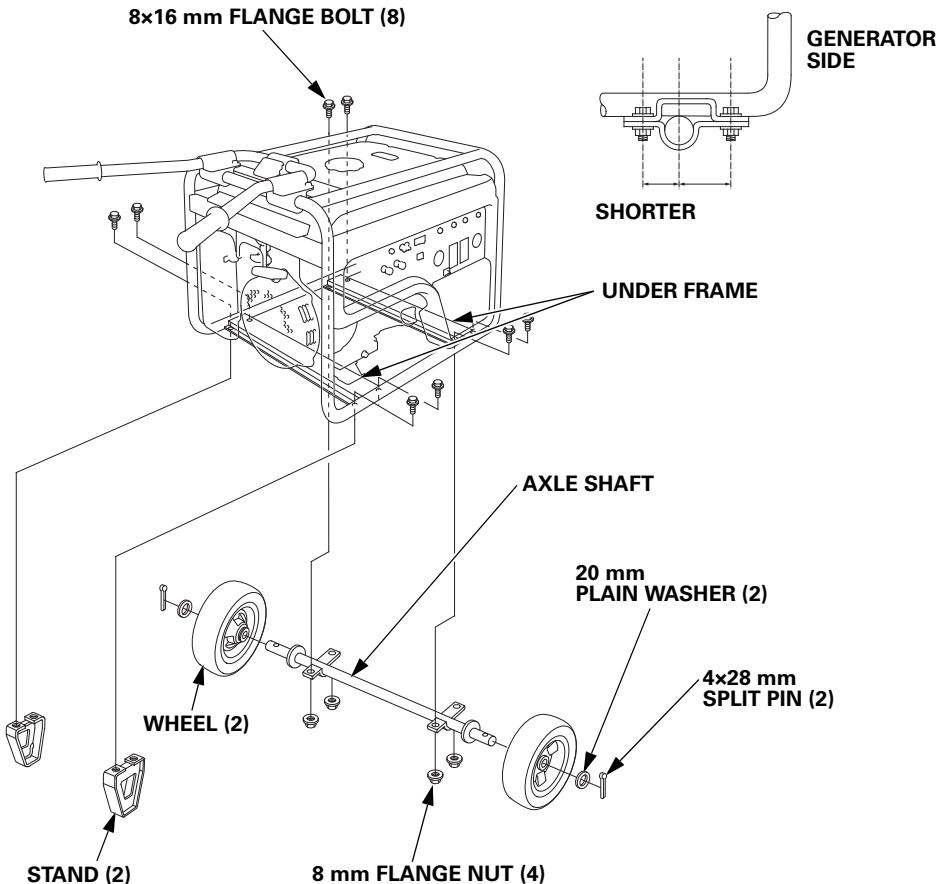

ASSEMBLY

Handle Installation

1. Install the handle folder assembly on the generator upper frame using the 8×18 mm flange bolts.
2. Install the handle assembly on the generator upper frame pipe using the 8×16 mm flange bolts, handle bush A, handle bush B, and handle lower bracket.

TORQUE: 17–22 lbf·ft (24–29 N·m, 2.4–3.0 kgf·m)

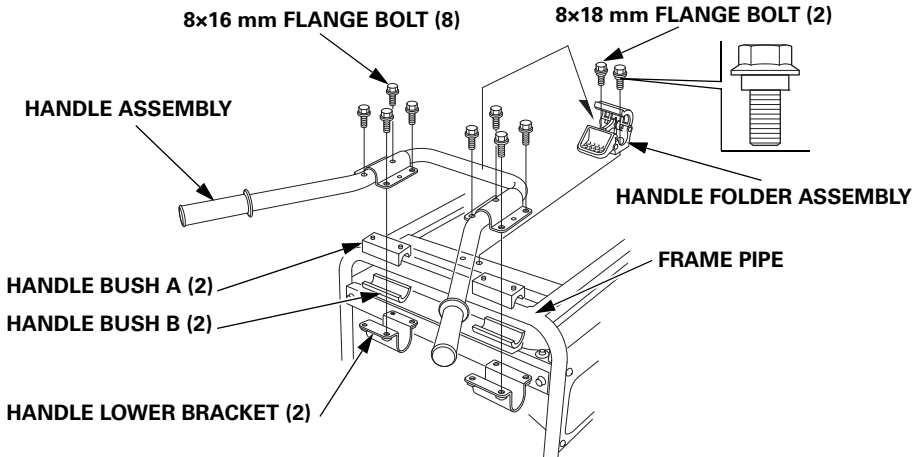

Operation must be checked after attaching the handle.

- Check that the handle can be folded smoothly.
- Check that the handle does not hang down by its own weight.

To extend handle:

Raise the handle to the horizontal position. The handle will click into place when locked.

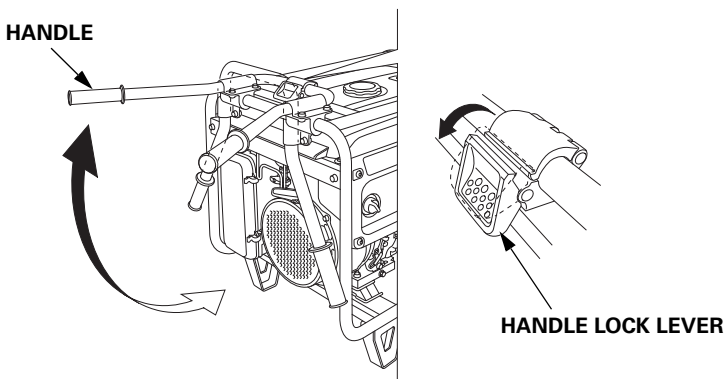

Hanger Kit Installation

1. Position the hanger at the generator's balance point as shown below.
2. Fit the end tabs of the hanger through the bracket slots, and bolt the brackets to the hanger and tighten securely.

TORQUE: 17–22 lbf·ft (24–29 N·m, 2.4–3.0 kgf·m)

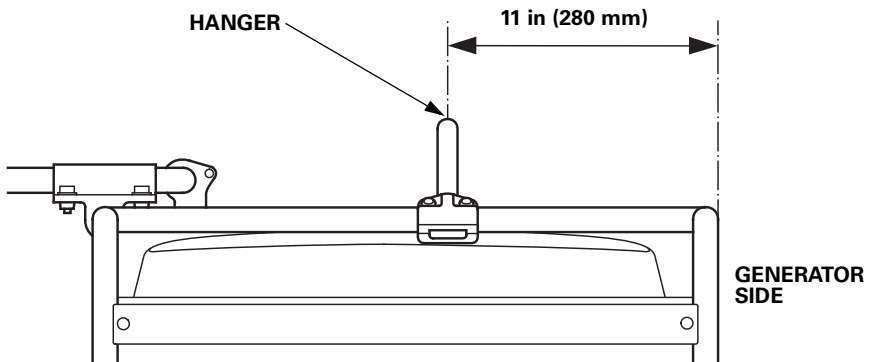
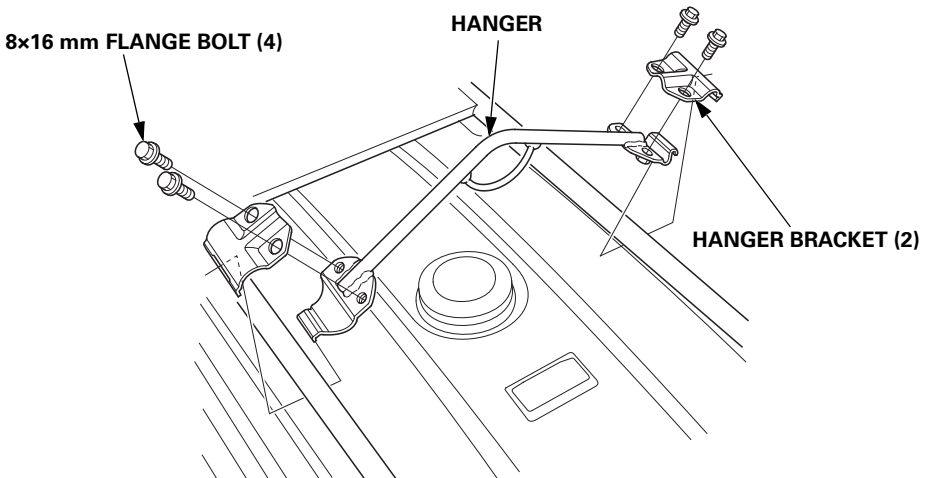

INITIAL USE INSTRUCTIONS

ENGINE OIL

The generator is shipped **WITHOUT OIL** in the engine.

1. Place the generator on a level surface.
2. Remove the oil filler cap/dipstick.
3. Add enough oil to bring the oil level to the upper limit mark on the oil dipstick. SAE 10W-30 API service category SJ or later (or equivalent) is recommended for general use; for additional recommendations (see page 51).

Maximum oil capacity: 1.2 US qt (1.1 L)

Do not overfill the engine with oil. If the engine is overfilled, the excess oil may be transferred to the air cleaner housing and air filter.

4. Reinstall the oil filler cap/dipstick securely.

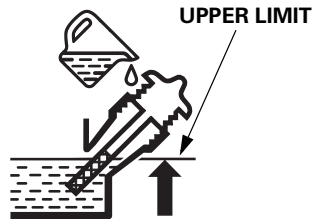
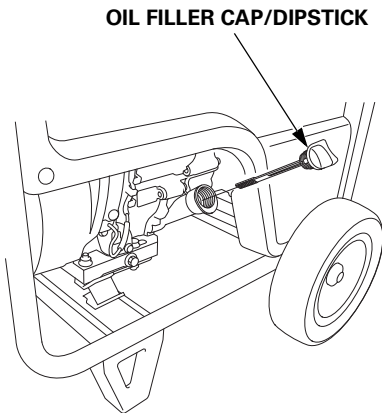

INITIAL USE INSTRUCTIONS

FUEL

Add fuel to the generator in a well-ventilated area. Never refuel the engine inside a building where gasoline fumes may reach flames or sparks. Keep gasoline away from appliance pilot lights, barbecues, electric appliances, power tools, etc. Spilled fuel is not only a fire hazard, it causes environmental damage. Wipe up spills immediately.

This engine is certified to operate on unleaded gasoline with a pump octane rating of 86 or higher. Refer to page 47 for additional fuel recommendations.

⚠ WARNING

Gasoline is highly flammable and explosive.

You can be burned or seriously injured when handling fuel.

- Stop the engine and keep heat, sparks, and flame away when refueling.
- Handle fuel only outdoors.
- Wipe up spills immediately.

1. Remove the fuel tank cap.
2. Fuel carefully to avoid spilling fuel. Do not fill the fuel tank above the upper level mark (red) on the fuel filter.
3. After refueling, reinstall the fuel tank cap securely.

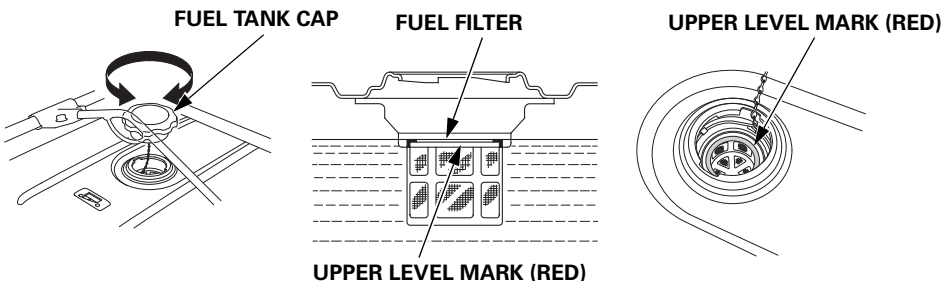

INITIAL USE INSTRUCTIONS

NOTICE

Fuel can damage paint and plastic. Be careful not to spill fuel when filling your fuel tank. Damage caused by spilled fuel is not covered under warranty.

Move the generator at least 10 feet (3 meters) away from the fueling source and site before starting the engine.

BEFORE OPERATION

Before using the generator, all generator operators must read the following chapters and sections:

- **GENERATOR SAFETY** (see pages 6–9)
- **CONTROLS & FEATURES** (see pages 10–22)
- **BEFORE OPERATION** (see pages 23–24)
- **OPERATION** (see page 25)
- **STARTING THE ENGINE** (see pages 26–28)
- **STOPPING THE ENGINE** (see page 29)
- **MAINTENANCE SCHEDULE** (see page 46)

REGISTRATION

Please Register Your Generator

If your dealer did not collect registration information from you, please take a few minutes and register your purchase with Honda. This allows us to contact you with any important updates regarding your generator. Please note registration is not required to obtain warranty service. You can register your generator by visiting the Honda Power Equipment website, www.hondapowerequipment.com and selecting Product Registration. Your information will remain confidential. It will not be released to any other company or organization.

INDEX

A	
Abnormal Voltage Detection Function.....	20
AC Applications	37
AC Circuit Breaker.....	16
AC Circuit Protectors	15
AC OPERATION.....	35
AC Receptacle Selection	38
AIR CLEANER ELEMENT CLEANING	54
AIR CLEANER SERVICE	52
Air Index	72
ARE YOU READY TO GET STARTED?.....	23
ASSEMBLY.....	78, 80
Auto Choke and Throttle Control System.....	21
AUTO THROTTLE SYSTEM.....	14, 41
Automatic Engine Stop Function	20
B	
BEFORE OPERATION.....	23, 86
C	
Carbon Monoxide Hazards	6
Carburetor Modification for High Altitude Operation.....	69
Check the Engine	24
Check the GFCI.....	24
Cleaning.....	59
COMPONENT & CONTROL LOCATIONS.....	10
Connections to a Building's Electrical System.....	42
CONSUMER INFORMATION.....	76
CONTENTS.....	3
CONTROLS.....	12
CONTROLS & FEATURES	10
Customer Service Information	77
D	
Dealer Locator Information.....	76

INDEX

E	
Electric Shock Hazards	7
Emission Control System Information.....	70
Engine Cylinder.....	62
ENGINE LACKS POWER.....	66
Engine Oil	62, 84
ENGINE OIL CHANGE.....	50
ENGINE OIL LEVEL CHECK	49
ENGINE OIL RECOMMENDATIONS	51
Engine Switch	12
ENGINE WILL NOT START.....	65
F	
FEATURES.....	20
Fire and Burn Hazards.....	7
Folding Handle.....	19
Fuel	59, 85
Fuel Gauge	22
FUEL RECOMMENDATIONS.....	48
Fuel Valve Lever.....	13
G	
GENERATOR SAFETY	6
GFCI OPERATION CHECK	30
Ground Fault Circuit Interrupter (GFCI)	17
Ground Terminal	22
H	
Handle Installation.....	82
Hanger Kit Installation.....	83
Honda Publications.....	76
I	
iAVR (Intelligent Auto Voltage Regulator)	21
IMPORTANT SAFETY INFORMATION	6
Important Safety Precautions	79
INITIAL USE INSTRUCTIONS	84
IS YOUR GENERATOR READY TO GO?.....	23

K	
Knowledge	23
L	
Loose Parts.....	80
M	
MAINTENANCE SAFETY.....	45
MAINTENANCE SCHEDULE	46
N	
NO POWER AT THE AC RECEPTACLES.....	67
O	
Oil Alert Function.....	20
Oil Alert System.....	20
OPERATION.....	25
Operator Responsibility	6
Overspeed Detection Function	20
P	
Power Producing Circuits.....	38
Q	
QUICK REFERENCE INFORMATION.....	Inside back cover
R	
Refuel With Care	8
REFUELING	47
REGISTRATION.....	86
REMOVAL FROM STORAGE.....	63

INDEX

S	
SAFE OPERATING PRECAUTIONS.....	25
SAFETY.....	78
SAFETY LABEL LOCATIONS.....	9
Safety Precautions.....	45
SEDIMENT CUP CLEANING.....	58
Serial Number Location	68
SERVICING YOUR GENERATOR	44
SPARK ARRESTER SERVICE.....	57
SPARK PLUG SERVICE.....	55
Special Requirements	43
Specifications.....	73
STANDBY POWER.....	42
Starter Grip.....	12
STARTING THE ENGINE	26
STOPPING THE ENGINE	29
STORAGE	59
STORAGE PRECAUTIONS	63
STORAGE PREPARATION.....	59
System Ground.....	42
T	
TAKING CARE OF UNEXPECTED PROBLEMS	65
TECHNICAL INFORMATION.....	68
THE IMPORTANCE OF MAINTENANCE.....	44
The Importance of Proper Assembly	78
TRANSPORTING.....	64
U	
Unpacking	80
V	
Voltage Selector Switch	13, 39
W	
Wheel Kit Installation	81
Wiring Diagram.....	74

MEMO

MEMO

QUICK REFERENCE INFORMATION

Fuel	Type	Unleaded gasoline with an ethanol content of no more than 10% and a pump octane rating of 86 or higher
Engine Oil	Type	SAE 10W-30, API SJ or later (or equivalent), for general use (see page 47)
Spark Plug	Type	BPR5ES (NGK) W16EPR-U (DENSO)
	Electrode Gap	0.028–0.031 in (0.7–0.8 mm)
Maintenance	Before each use	Check engine oil level. Check air filter. Check GFCI operation.
	First 20 hours	Change engine oil.
	Subsequent	See <i>MAINTENANCE SCHEDULE</i> (see page 42)

HONDA

The Power of Dreams

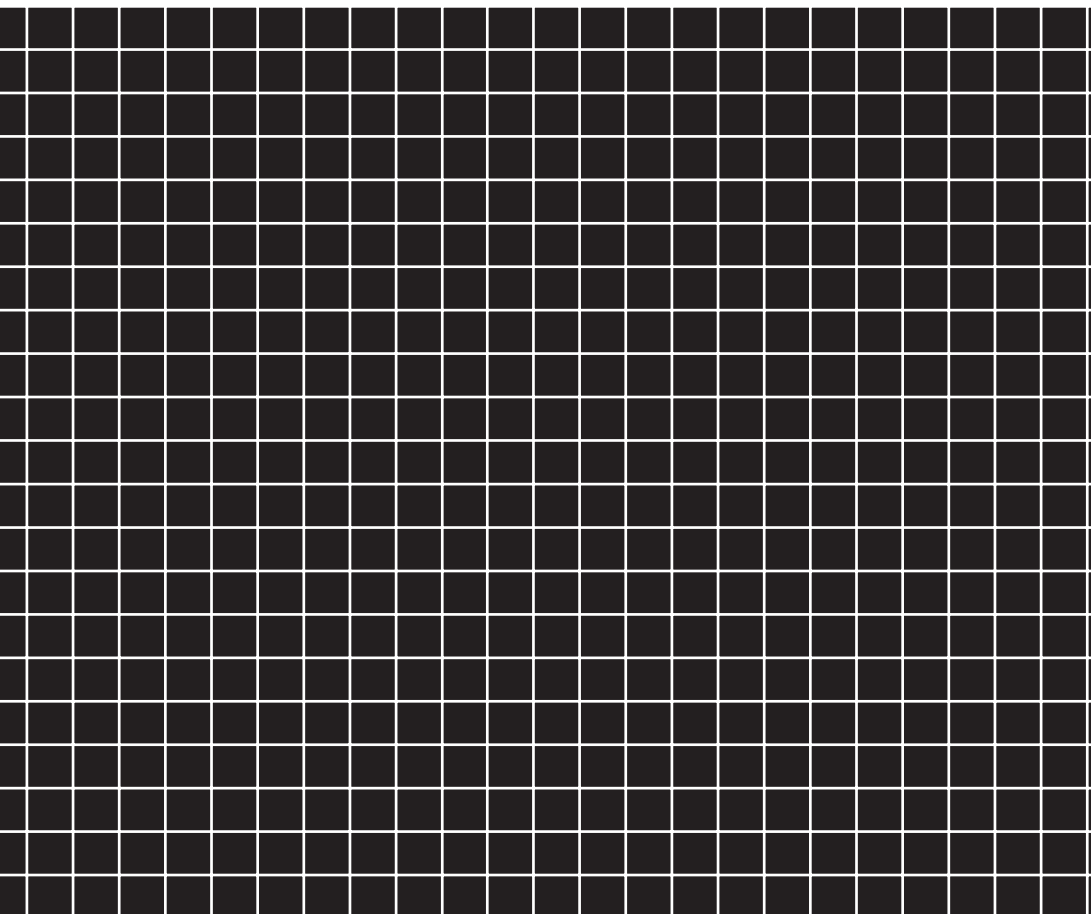

31Z23810
00X31-Z23-8100



Printed on
Recycled Paper

AHM.35.2015.01
PRINTED IN U.S.A.