

## X-SMART (EL1250H) LED LIGHT TOWER

### Diesel Powered

Carbon Footprint - **82% LESS**  
Annual Fuel Cost - **61% LESS**  
Total Operating Cost - **63% LESS**  
Compared to a Metal Halide

- Full run time 288 hrs - that's almost a full month of darkness on one tank of diesel! Refuel once a month verses five times a month with metal halide towers. Save on fuel and labor refueling costs!
- 4 x 320W high efficiency LED light heads have a 5 year warranty and are easily tilted & rotated by hand covering a 53,820 sq ft area.
- Kubota Z482-E4B engine with 1,000 hour service interval
- Hydraulically operated vertical mast fully raises in 10 sec. with the push of a button with 26' maximum height.
- Set the timer and go! No need to send labor to start every night - 16 event 7 day digital timer, and automatic dusk to dawn operation. Save time and money!
- Built for a long life! Rugged 10 gauge steel enclosure and fenders are galvanized and powder coated inside and out. Documented towers with 30,000+ hours.
- 110% containment base

## Trime X-SMART (EL1250H) Specifications

Mast, Dimensions & Weight	
Mast Height	26'
Wind Rating	50 mph
Fully Retractable Stabilizers	Y
Axle	Torsion
Drawbar	Tubular Steel
Unit Dimensions - Stowed	63" x 56" x 95"
Operating Dimensions	98" x 100" x 315"
Dry Weight	2107
Operating Weight	2429
Engine	
Make	Kubota* Kohler*
Model	Z482-E4B KDW702
Emission Regulation	Tier 4
Type	Vertical 4 Cycle Liquid Cooling Diesel
Cylinder	2
Displacement / L (cu. In.)	0.479 (29.23)
Combustion System	IDI
Intake System	Naturally Aspirated
Maximum Speed	1800 rpm
Sound Level @ 23'	65 dBA
Alternator	
Make	Linz
Output	4.2 kVA
Hz	60
Fuel	
Type	Diesel
Fuel Capacity	46 gal.
Run Time	288 Hrs

\*Specs subject to change. Ask about engine.

### Applications



Illuminated area = 53,820 sq ft



## OPTIONS



### Skid Mount

A skid mount version of the X-Smart is available from the factory. The skid itself is also available as a plug and play for existing towers. Remove existing undercarriage and bolt on skid.

### Anti-Glare Light Heads

Anti-glare light heads are available as an option in place of the standard 320W light head. There is a 10% less square footage difference with the anti-glare heads, but more economical than other options out there.

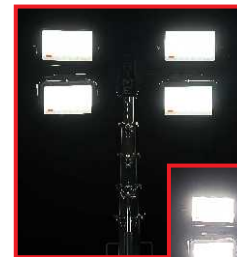

Anti-Glare Light Heads



320W Light Heads

### Receiver Hitch

The receiver hitch gives user the ability to tow two towers together safely, one hooked to the back of the other. It bolts into the existing frame and axle.

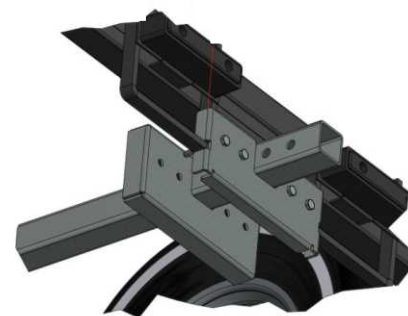

**Discount  
Equipment**

www.discount-equipment.com