

# E18MCL

DRIVEABLE VERTICAL LIFT



www.discount-equipment.com



## STANDARD SPECIFICATIONS

Performance	Indoor	Outdoor
Platform Height (Elevated)	18-ft / 5.5-m	13-ft / 4-m
Working Height	24-ft / 7.5-m	19-ft / 6-m
Platform Capacity	400-lb / 181-kg	400-lb / 181-kg
Extension Deck Capacity	250-lb / 113-kg	250-lb / 113-kg
Number of Occupants	1	1
Lift / Lower Time <sup>1</sup>	23/23 seconds	23/23 seconds
Maximum Drive Height	Fully Elevated	13-ft / 4-m
Weight*	1,950-lb / 885-kg	1,950-lb / 885-kg
Ground Bearing Pressure	123.3 psi / 8.67-kg/cm <sup>2</sup>	123.3 psi / 8.67-kg/cm <sup>2</sup>
Drive Speed (Elevated)	0.5 mph / .8 km/h	0.5 mph / .8 km/h
Drive Speed (Lowered)	2.5 mph / 4 km/h	2.5 mph / 4 km/h
Gradeability	30%	30%
Turning Radius (Inside)	Zero	Zero
Turning Radius (Outside)	55-in / 1.4-m	55-in / 1.4-m

## Power Source

Battery	Four 6V - 220 AH (2X More Duty Cycles Over Competition)
Charger	27 amp
Drive	4 Brush Direct Electric Drive (Planetary Gear)

## Lift & Steer Systems

Lift	Hydraulic
Steer	Scissor

## Tires

Front / Rear	8-in / 10 x 3-in Non-Marking
--------------	------------------------------

## Brakes

Electric	
----------	--

## STANDARD FEATURES

- 27 amp Multi-Function Universal Charger
- 29.5 x 51-in Front Entry Extension Platform with Saloon Doors
- AC Receptacle in Platform
- Active Pothole Protection System
- All Motion Alarm
- Analyzer Port for Diagnostics
- Battery Condition Indicator
- DC Electric Drive
- Dynamic Braking
- Electric Brake Release
- Fork Lift Pockets
- Greaseless Kingpin Joints
- Horn
- Hourmeter
- Lanyard Attach Points
- Lifting and Tie Down Points
- Load Sensing System
- Manual Descent
- Mast Maintenance Prop
- Movable, Removable Platform Control with 6-ft Coiled Cable
- Multi-Display Indicator
- Proportional Controls
- Telematics Ready
- Tilt Alarm and Light

## QUICK CHANGE PLATFORM OPTIONS

- 30 x 26-in Platform
- 30 x 26-in Platform
- Platform Capacity, 450-lb
- Front Entry, Drop Bar
- Narrow Platform
- 22 x 26-in
- Platform Capacity, 450-lb
- Front Entry, Drop Bar
- Also Available as Spare Platform<sup>3</sup>
- Front Entry Extension Platform
- 29.5 x 51-in
- Platform Capacity, 400-lb
- Extension Capacity, 250-lb
- Platform Entry Styles
- Front Entry Saloon Doors
- Front Entry Drop Bar
- Fold-Down Work Tray Platform
- 28 x 29.5-in
- Platform Capacity, 400-lb
- Tray Capacity, 100-lb
- Platform Entry Styles
- Side Entry Saloon Doors
- Side Entry Drop Bar
- Aluminum Tray with Side Entry Saloon Doors

## KEY SPECS

**Platform Height**  
18-ft / 5.5-m

**Turning Radius**  
Zero

**Platform Capacity [Standard Platform]**  
400-lb / 181-kg

**Stowed Drive Speed**  
2.5 mph / 4 km/h

## KEY FEATURES

- Designed with the operator in mind, featuring familiar controls, scissor steering, ergonomic joystick, ease of entry/exit from platform and interchangeable control box with other scissor models.
- Lightweight and compact footprint is ideal for sensitive flooring and accessing tight spaces with high transportability.
- Increase productivity with this wind-rated machine featuring longer running batteries and optional extensions, trays and platforms.
- Quick access to key, known scissor components and durable mast protection offers efficient serviceability while the multi-display indicator provides real-time fault code and maintenance information to maximize uptime.

## ACCESSORIES & OPTIONS

- 4 x 6V 213 Amp-Hr AGM Batteries
- Anti-Vandalism Package
- CleanGuard® Leak Containment System
- ClearSky™ Telematics
- Crane Hook
- Dual Amber Beacon
- Floor Mat
- Front and Side Bumpers
- Gate Latch
- Lithium Battery (1)
- Lithium+ Batteries (2)
- Platform Entry Step
- USB Charger & Phone Cradle
- Stock Picker (E18MSP) Package<sup>2</sup>

\*Certain options or country standards increase weight.

1. Average range, refer to Operations Manual.

2. Includes standard 28 x 29.5-in fold-down work tray platform with side entry saloon doors with gate alarm, dual amber beacons and floor mat.

3. If choosing a platform option, the machine will ship with the selected platform. If choosing the spare platform, the machine will ship with first selected platform, plus the spare platform. If no platform is selected, the standard platform will ship.

# E18MCL

## DRIVEABLE VERTICAL LIFT

VERTICAL LIFT



### DIMENSIONS

All dimensions are approximate

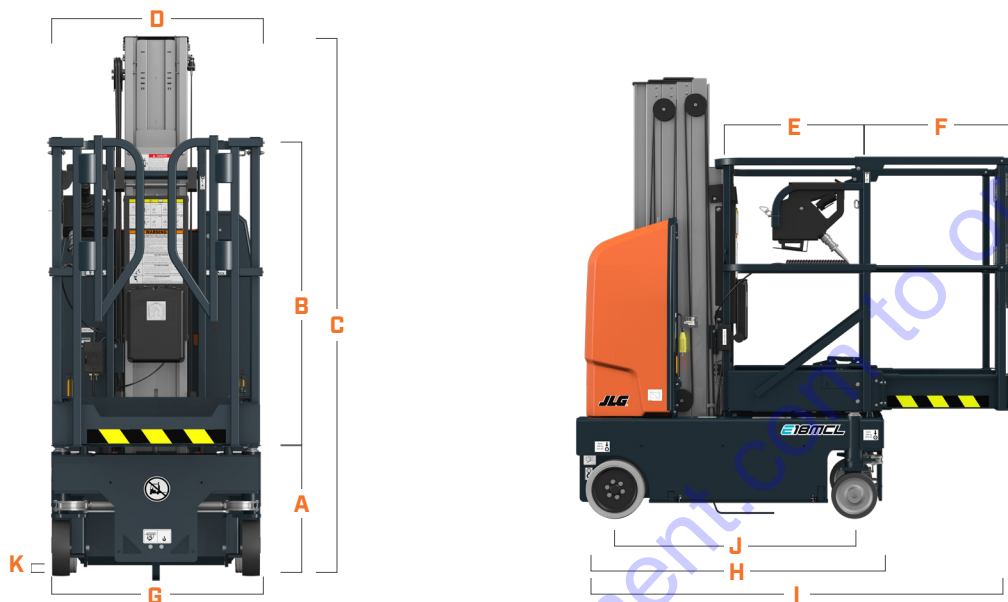

A. Platform Entry Height	18.5-in / 47-cm
B. Platform Rail Height	43.8-in / 1.11-m
C. Machine Height	78-in / 1.98-m
D. Platform Width	29.5-in / 75-cm
E. Platform Length	32-in / 81-cm
F. Platform Extension	19.5-in / 50-cm
G. Machine Width	30-in / 76-cm
H. Machine Length - Retracted Extension	57.6-in / 1.46-m
I. Machine Length - Extended Extension	76.5-in / 1.94-m
J. Wheelbase	41.4-in / 1.05-m
K. Ground Clearance	2.5-in / 6.35-cm



[www.discount-equipment.com](http://www.discount-equipment.com)



We provide coverage for one (1) full year, and cover all specified major structural components for five (5) years. Due to continuous product improvements, we reserve the right to make specification and/or equipment changes without prior notification. This machine meets or exceeds applicable ANSI and CSA requirements based on machine configuration as originally manufactured for intended applications. Please reference the serial number plate on the machine for additional information.



An Oshkosh Corporation Company