

OPERATION AND PARTS MANUAL



MODEL GA3.6HR PORTABLE GENERATORS (HONDA GX240RT2EDN2 GASOLINE ENGINE)

Revision #0 (09/17/14)

To find the latest revision of this
publication, visit our website at:
www.multiquip.com



THIS MANUAL MUST ACCOMPANY THE EQUIPMENT AT ALL TIMES.

PROPOSITION 65/START FIRES WARNINGS

WARNING

CALIFORNIA — Proposition 65 Warning

Gasoline engine exhaust and some of its constituents are known to the State of California to cause cancer, birth defects and other reproductive harm.

WARNING

Operation of this equipment may create sparks that can start fires around dry vegetation. A spark arrestor may be required. The operator should contact local fire agencies for laws or regulations relating to fire prevention requirements.

TABLE OF CONTENTS

GA3.6HR 60 Hz Portable Generator

Proposition 65/Start Fires Warnings.....	2
Table Of Contents.....	3
Nameplate/Safety Information.....	4
Parts Ordering Procedures.....	5
Safety Information.....	6-11
Specifications (Generator).....	12
Specifications (Engine).....	13
Dimensions.....	14
Installation.....	16-17
General Information.....	18
Components (Generator).....	19-21
Inspection/Setup.....	22-23
Operation.....	24-26
Shutdown.....	27
Preparation For Long Term Storage.....	28
Maintenance.....	29-33
Generator Wiring Diagram.....	34
Troubleshooting (Engine).....	35-36
Troubleshooting (Generator).....	37
Explanation of Code in Remarks Column.....	38
Suggested Spare Parts.....	39

Component Drawings

Nameplate And Decals Assembly.....	40-41
Generator Assembly.....	42-43
Control Box Assembly.....	44-45
Pipe Frame Assembly.....	46-47
Muffler Assembly.....	48-49
Wheel Kit Assembly.....	50-51

Honda GX240RT2EDN2 Gasoline Engine

Air Cleaner Assembly.....	52-53
Camshaft Assembly.....	54-55
Carburetor Assembly.....	56-57
Control Assembly.....	58-59
Crankcase Cover Assembly.....	60-61
Crankshaft Assembly.....	62-63
Cylinder Barrel Assembly.....	64-65
Cylinder Head Assembly.....	66-67
Fan Cover Assembly.....	68-69
Flywheel Assembly.....	70-71
Ignition Coil Assembly.....	72-73
Piston Assembly.....	74-75
Recoil Starter Assembly.....	76-77
Solenoid Assembly.....	78-79
Engine Decals Assembly.....	80-81

Terms and Conditions of Sale — Parts.....	82
---	----

NOTICE

Specifications and part numbers are subject to change without notice.

NAMEPLATE/SAFETY INFORMATION

NAMEPLATE AND SAFETY LABELS

Safety labels are attached to the generator as shown in Figure 1. Keep these safety labels clean at all times. When the safety labels become worn or damaged and need to be replaced, contact your nearest dealer or the Multiquip Parts Dept.

NOTICE

For safety label part numbers, reference the parts section of this manual.

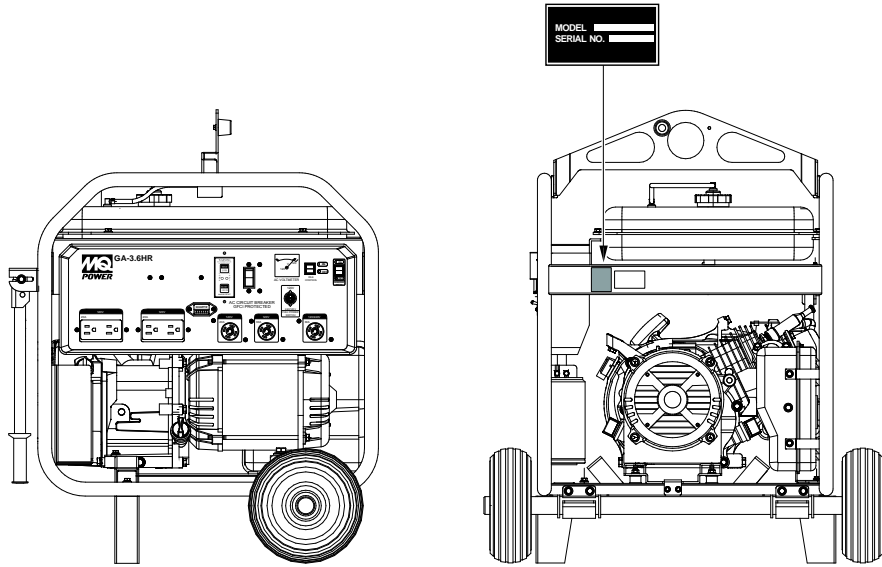
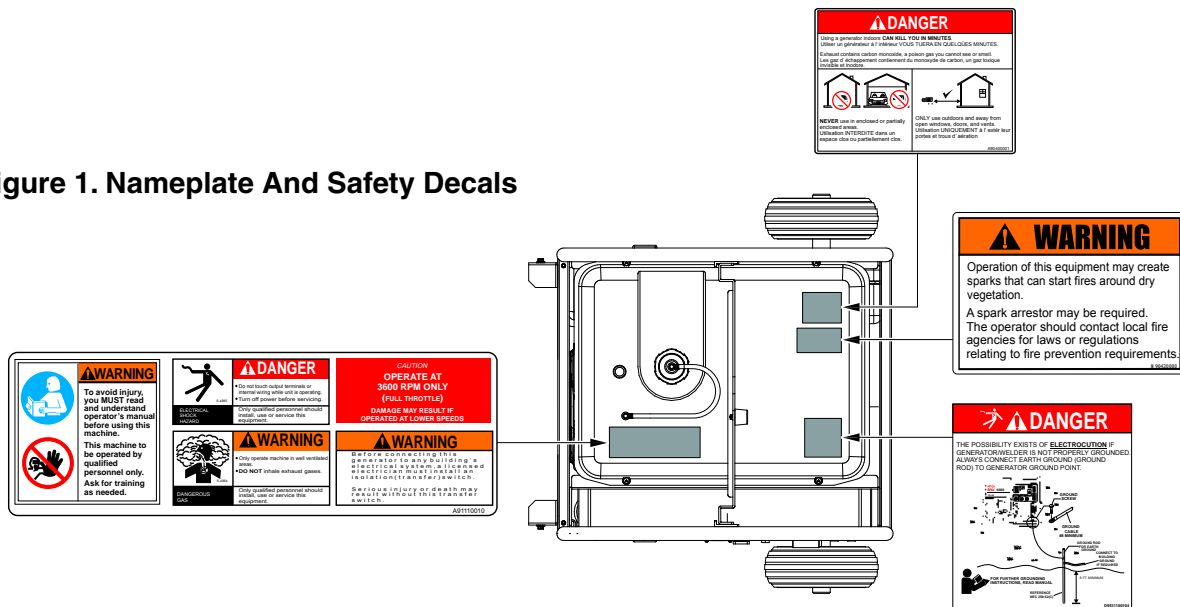

Figure 1. Nameplate And Safety Decals



PARTS ORDERING PROCEDURES

Ordering parts has never been easier! Choose from three easy options:

Effective:
January 1st, 2006

www.multiquip.com



Order via Internet (Dealers Only):

Order parts on-line using Multiquip's SmartEquip website!

- View Parts Diagrams
- Order Parts
- Print Specification Information



If you have an MQ Account, to obtain a Username and Password, E-mail us at: parts@multiquip.com.

To obtain an MQ Account, contact your District Sales Manager for more information.

Goto www.multiquip.com and click on **Order Parts** to log in and save!

Use the **internet** and qualify for a **5% Discount** on *Standard orders* for all orders which include complete part numbers.*

Note: Discounts Are Subject To Change

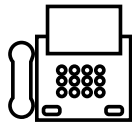

Order via Fax (Dealers Only):

All customers are welcome to order parts via Fax.

Domestic (US) Customers dial:
1-800-6-PARTS-7 (800-672-7877)

Fax your order in and qualify for a **2% Discount** on *Standard orders* for all orders which include complete part numbers.*

Note: Discounts Are Subject To Change



Order via Phone: Domestic (US) Dealers Call:
1-800-427-1244

Non-Dealer Customers:

Contact your local Multiquip Dealer for parts or call 800-427-1244 for help in locating a dealer near you.



International Customers should contact their local Multiquip Representatives for Parts Ordering information.

When ordering parts, please supply:

- | | |
|---|--|
| <input type="checkbox"/> Dealer Account Number | <input type="checkbox"/> Specify Preferred Method of Shipment: |
| <input type="checkbox"/> Dealer Name and Address | <input checked="" type="checkbox"/> UPS/Fed Ex <input checked="" type="checkbox"/> DHL |
| <input type="checkbox"/> Shipping Address (if different than billing address) | <input type="checkbox"/> Priority One <input checked="" type="checkbox"/> Truck |
| <input type="checkbox"/> Return Fax Number | <input type="checkbox"/> Ground |
| <input type="checkbox"/> Applicable Model Number | <input type="checkbox"/> Next Day |
| <input type="checkbox"/> Quantity, Part Number and Description of Each Part | <input type="checkbox"/> Second/Third Day |

NOTICE

All orders are treated as *Standard Orders* and will ship the same day if received prior to 3PM PST.

WE ACCEPT ALL MAJOR CREDIT CARDS!



SAFETY INFORMATION

Do not operate or service the equipment before reading the entire manual. Safety precautions should be followed at all times when operating this equipment. Failure to read and understand the safety messages and operating instructions could result in injury to yourself and others.

SAFETY MESSAGES

The four safety messages shown below will inform you about potential hazards that could injure you or others. The safety messages specifically address the level of exposure to the operator and are preceded by one of four words: **DANGER**, **WARNING**, **CAUTION** or **NOTICE**.

SAFETY SYMBOLS

 **DANGER**

Indicates a hazardous situation which, if not avoided, **WILL** result in **DEATH** or **SERIOUS INJURY**.

 **WARNING**

Indicates a hazardous situation which, if not avoided, **COULD** result in **DEATH** or **SERIOUS INJURY**.





 **CAUTION**

Indicates a hazardous situation which, if not avoided, **COULD** result in **MINOR** or **MODERATE INJURY**.

NOTICE

Addresses practices not related to personal injury.

Potential hazards associated with the operation of this equipment will be referenced with hazard symbols which may appear throughout this manual in conjunction with safety messages.

Symbol	Safety Hazard
	Lethal exhaust gas hazards
	Explosive fuel hazards
	Burn hazards
	Overspeed hazards
	Electric shock hazards

SAFETY INFORMATION

GENERAL SAFETY

CAUTION

- **NEVER** operate this equipment without proper protective clothing, shatterproof glasses, respiratory protection, hearing protection, steel-toed boots and other protective devices required by the job or city and state regulations.



- **NEVER** operate this equipment when not feeling well due to fatigue, illness or when under medication.
- **NEVER** operate this equipment under the influence of drugs or alcohol.



- **ALWAYS** check the equipment for loosened threads or bolts before starting.
- **DO NOT** use the equipment for any purpose other than its intended purposes or applications.

NOTICE

- This equipment should only be operated by trained and qualified personnel 18 years of age and older.
- Whenever necessary, replace nameplate, operation and safety decals when they become difficult read.
- Manufacturer does not assume responsibility for any accident due to equipment modifications. Unauthorized equipment modification will void all warranties.
- **NEVER** use accessories or attachments that are not recommended by Multiquip for this equipment. Damage to the equipment and/or injury to user may result.
- **ALWAYS** know the location of the nearest fire extinguisher.
- **ALWAYS** know the location of the nearest first aid kit.



- **ALWAYS** know the location of the nearest phone or **keep a phone on the job site**. Also, know the phone numbers of the nearest **ambulance, doctor** and **fire department**. This information will be invaluable in the case of an emergency.

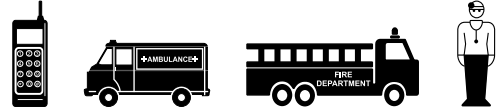

GENERATOR SAFETY

DANGER

- **NEVER** operate the equipment in an explosive atmosphere or near combustible materials. An explosion or fire could result causing severe **bodily harm or even death**.



WARNING

- **NEVER** disconnect any **emergency or safety devices**. These devices are intended for operator safety. Disconnection of these devices can cause severe injury, bodily harm or even death. Disconnection of any of these devices will void all warranties.

CAUTION

- **NEVER** lubricate components or attempt service on a running machine.

NOTICE

- **ALWAYS** ensure generator is on level ground before use.
- **ALWAYS** keep the machine in proper running condition.
- Fix damage to machine and replace any broken parts immediately.
- **ALWAYS** store equipment properly when it is not being used. Equipment should be stored in a clean, dry location out of the reach of children and unauthorized personnel

SAFETY INFORMATION

ENGINE SAFETY

DANGER

- The engine fuel exhaust gases contain poisonous carbon monoxide. This gas is colorless and odorless, and can cause death if inhaled.
- The engine of this equipment requires an adequate free flow of cooling air. **NEVER** operate this equipment in any enclosed or narrow area where free flow of the air is restricted. If the air flow is restricted it will cause injury to people and property and serious damage to the equipment or engine.

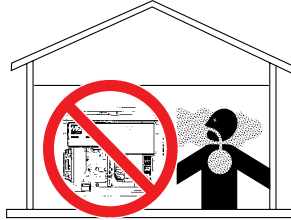

WARNING

- **NEVER** operate the engine with heat shields or guards removed.
- **DO NOT** remove the engine oil drain plug while the engine is hot. Hot oil will gush out of the engine crankcase and severely scald any persons in the general area of the generator.

CAUTION

- **NEVER** touch the hot exhaust manifold, muffler or cylinder. Allow these parts to cool before servicing equipment.



NOTICE

- **NEVER** run engine without an air filter or with a dirty air filter. Severe engine damage may occur. Service air filter frequently to prevent engine malfunction.
- **NEVER** tamper with the factory settings of the engine or engine governor. Damage to the engine or equipment can result if operating in speed ranges above the maximum allowable.
- State Health Safety Codes and Public Resources Codes specify that in certain locations, spark arresters must be used on internal combustion engines that use hydrocarbon fuels. A spark arrester is a device designed



to prevent accidental discharge of sparks or flames from the engine exhaust. Spark arresters are qualified and rated by the United States Forest Service for this purpose. In order to comply with local laws regarding spark arresters, consult the engine distributor or the local Health and Safety Administrator.

FUEL SAFETY

DANGER

- **DO NOT** add fuel to equipment if it is placed inside truck bed with plastic liner. Possibility exists of explosion or fire due to static electricity.

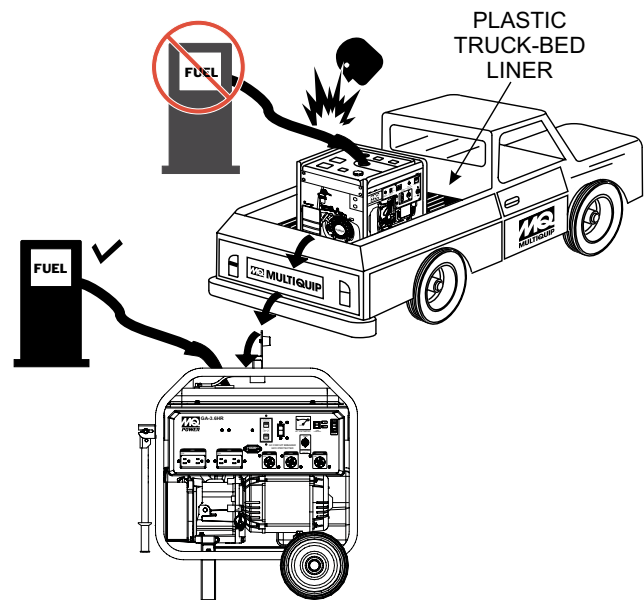

- **DO NOT** start the engine near spilled fuel or combustible fluids. Diesel fuel is extremely flammable and its vapors can cause an explosion if ignited.
- **ALWAYS** refuel in a well-ventilated area, away from sparks and open flames.
- **ALWAYS** use extreme caution when working with **flammable** liquids.
- **DO NOT** fill the fuel tank while the engine is running or hot.
- **DO NOT** overfill tank, since spilled fuel could ignite if it comes into contact with hot engine parts or sparks from the ignition system.
- Store fuel in appropriate containers, in well-ventilated areas and away from sparks and flames.

SAFETY INFORMATION

- **NEVER** use fuel as a cleaning agent.
- **DO NOT** smoke around or near the equipment. Fire or explosion could result from fuel vapors or if fuel is spilled on a hot engine.



ELECTRICAL SAFETY

DANGER

- Turn generator and all circuit breakers **OFF** before performing maintenance on the generator or making contact with output receptacles.

- **NEVER** insert any objects into the output receptacles during operation. This is extremely dangerous. The possibility exists of **electrical shock, electrocution or death.**



- Backfeed to a utility system can cause **electrocution** and/or property damage. **NEVER** connect the generator to a building's electrical system without a transfer switch or other approved device. All installations should be performed by a **licensed electrician** in accordance with all applicable laws and electrical codes. Failure to do so could result in electrical shock or burn, causing **serious injury or even death.**



Power Cord/Cable Safety

DANGER

- **NEVER** let power cords or cables **lay in water.**
- **NEVER stand in water** while AC power from the generator is being transferred to a load.
- **NEVER** use **damaged** or **worn** cables or cords when connecting equipment to generator. Inspect for cuts in the insulation.

- **NEVER** grab or touch a live power cord or cable with wet hands. The possibility exists of **electrical shock, electrocution or death.**



- Make sure power cables are securely connected to the generator's output receptacles. Incorrect connections may cause electrical shock and damage to the generator.

NOTICE

- **ALWAYS** make certain that proper power or extension cord has been selected for the job. See Cable Selection Chart in this manual.

Grounding Safety

DANGER

- **ALWAYS** make sure that electrical circuits are properly grounded to a suitable earth ground (ground rod) per the National Electrical Code (NEC) and local codes before operating generator. **Severe injury or death by electrocution** can result from operating an ungrounded generator.

- **NEVER** use gas piping as an electrical ground.

BATTERY SAFETY (ELECTRIC START ONLY)

DANGER

- **DO NOT** drop the battery. There is a possibility that the battery will explode.

- **DO NOT** expose the battery to open flames, sparks, cigarettes, etc. The battery contains combustible gases and liquids. If these gases and liquids come into contact with a flame or spark, an explosion could occur.



- **DO NOT** charge battery if frozen. Battery can explode. When frozen, warm the battery to at least 61°F (16°C).

WARNING

- **ALWAYS** wear safety glasses when handling the battery to avoid eye irritation. The battery contains acids that can cause injury to the eyes and skin.



- Use well-insulated gloves when picking up the battery.
- **ALWAYS** keep the battery charged. If the battery is not charged, combustible gas will build up.
- **ALWAYS** recharge the battery in a well-ventilated environment to avoid the risk of a dangerous concentration of combustible gasses.

SAFETY INFORMATION

- If the battery liquid (dilute sulfuric acid) comes into contact with **clothing or skin**, rinse skin or clothing immediately with plenty of water.
- If the battery liquid (dilute sulfuric acid) comes into contact with **eyes**, rinse eyes immediately with plenty of water and contact the nearest doctor or hospital to seek medical attention.

CAUTION

- **ALWAYS** disconnect the **NEGATIVE** battery terminal before performing service on the generator.
- **ALWAYS** keep battery cables in good working condition. Repair or replace all worn cables.

TRANSPORTING SAFETY

CAUTION

- **NEVER** allow any person or animal to stand underneath the equipment while lifting.

NOTICE

- Before lifting, make sure that the equipment parts (lifting bail if equipped) are not damaged and screws are not loose or missing.
- Always make sure crane or lifting device has been properly secured to the lifting bail (hook) of the equipment.
- **ALWAYS** shutdown engine before transporting.
- **NEVER** lift the equipment while the engine is running.
- Tighten fuel tank cap securely and close fuel cock to prevent fuel from spilling.
- Use adequate lifting cable (wire or rope) of sufficient strength.
- Use one point suspension hook and lift straight upwards.
- **DO NOT** lift machine to unnecessary heights.
- **ALWAYS** tie down equipment during transport by securing the equipment with rope.

ENVIRONMENTAL SAFETY/DECOMMISSIONING

NOTICE

Decommissioning is a controlled process used to safely retire a piece of equipment that is no longer serviceable. If the equipment poses an unacceptable and unrepairable safety risk due to wear or damage or is no longer cost effective to maintain (beyond life-cycle reliability) and is to be decommissioned (demolition and dismantlement), be sure to follow rules below.

- **DO NOT** pour waste or oil directly onto the ground, down a drain or into any water source.
- Contact your country's Department of Public Works or recycling agency in your area and arrange for proper disposal of any electrical components, waste or oil associated with this equipment.



- When the life cycle of this equipment is over, remove battery (if equipped) and bring to appropriate facility for lead reclamation. Use safety precautions when handling batteries that contain sulfuric acid.
- When the life cycle of this equipment is over, it is recommended that the unit frame and all other metal parts be sent to a recycling center.

Metal recycling involves the collection of metal from discarded products and its transformation into raw materials to use in manufacturing a new product.

Recyclers and manufacturers alike promote the process of recycling metal. Using a metal recycling center promotes energy cost savings.

EMISSIONS INFORMATION

NOTICE

The gasoline engine used in this equipment has been designed to reduce harmful levels of carbon monoxide (CO), hydrocarbons (HC) and nitrogen oxides (NOx) contained in gasoline exhaust emissions.

This engine has been certified to meet US EPA Evaporative emissions requirements in the installed configuration.

Attempting to modify or make adjustments to the engine emission system by unauthorized personnel without proper training could damage the equipment or create an unsafe condition.

Additionally, modifying the fuel system may adversely affect evaporative emissions, resulting in fines or other penalties.

Emission Control Label

The emission control label is an integral part of the emission system and is strictly controlled by regulation(s).

The label must remain with the engine for its entire life.

If a replacement emission label is needed, please contact your authorized Honda Engine Distributor.

SPECIFICATIONS (GENERATOR)

Table 1. Specifications (Generator)		
AC Generator	Model	GA3.6HR
	Type	Brushless Revolving Field Type
	Excitation	Solid State, Statically Excited System
	Speed	3,600 RPM
	Cooling System	Self-Ventilation
	Fuel Capacity	5 gallons (19 liters)
60 Hz AC Power Source	Continuous Power Output	3.2 kW
	Max Power Output	3.6 kW
	Rated Voltage	120/240V
	Current Max/Continuous (120V)	30/26.7 amps
	Current Max/Continuous (240V)	15/13.3 amps
	Phase	Single Phase (4 wire)
	Frequency	60 Hz
	Power Factor	1
Dimensions (L x W x H)	28.0 x 30.9 X 29.7 in. (710 X 785 X 755 mm)	
Dry Net Weight	196 lbs. (89 kg.)	

NOTICE

In keeping with Multiquip's policy of constantly improving its products, the specifications quoted herein are subject to change without prior notice.

SPECIFICATIONS (ENGINE)

Table 2. Specifications (Engine)		
Engine	Model	HONDA GX240RT2EDN2
	Type	Air-cooled 4 stroke, Single Cylinder, OHV, Horizontal Shaft Gasoline Engine
	Bore X Stroke	3.03 in. X 2.28 in. (77 mm x 58 mm.)
	Displacement	16.5 cu-in (270 cm ³)
	Max Output	7.9 H.P./3600 R.P.M.
	Fuel	Unleaded Automobile Gasoline
	Lube Oil Capacity	1.16 quarts (1.1 liters)
	Oil Alert System	Yes
	Speed Control Method	Centrifugal Fly-weight Type
	Starting Method	Recoil Start
Dimensions (L x W x H)	15.0 x 16.8 X 16.6in. (381 X 428 X 422 mm)	
Dry Net Weight	56.8 lbs. (25.8 kg.)	

Effects of Altitude and Heat

The maximum output of the engines listed above are applicable to supplying electrical power for continuous service at ambient conditions in accordance with SAE Test cord J607. The above ambient conditions are at standard sea level, with a barometric reading of 29.92 inches and a temperature of 60° F (15.5° C).

Generally, the engine's output power will decrease 3-1/2% for each 1000 feet (305 meters) of altitude above sea level, and 1% for each 10° F (-12.2° C) above the standard temperature of 60° F (15.5° C).

DIMENSIONS

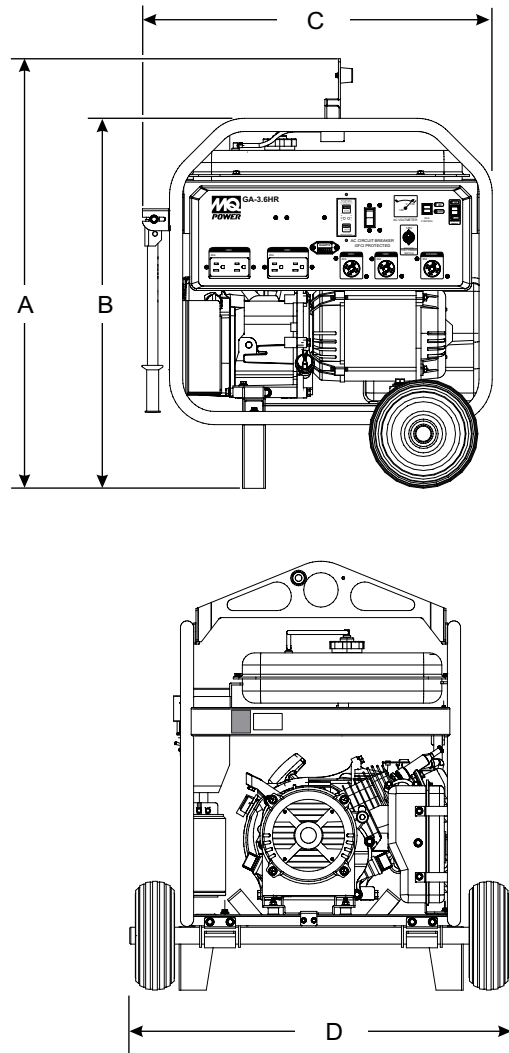

Figure 2. Dimensions

Table 3. Generator Dimensions		
REFERENCE LETTER	DESCRIPTION	DIMENSIONS: IN. (MM)
A	HEIGHT (LIFTING BALE)	34.1 (865)
B	HEIGHT (FRAME)	29.7 (755)
C	LENGTH	29.9 (760)
D	WIDTH	30.9 (785)

CONNECTING THE GROUND

The nut and ground terminal on the generator should always be used to connect the generator to a suitable ground. The ground cable should be #8 size wire (aluminum) minimum. If copper wire is used, #10 size wire minimum should be used.

At the generator, connect the terminal of the ground cable between the lock washer and the nut (Figure 3) and tighten the nut fully. Connect the other end of the ground cable to a suitable earth ground (ground rod).

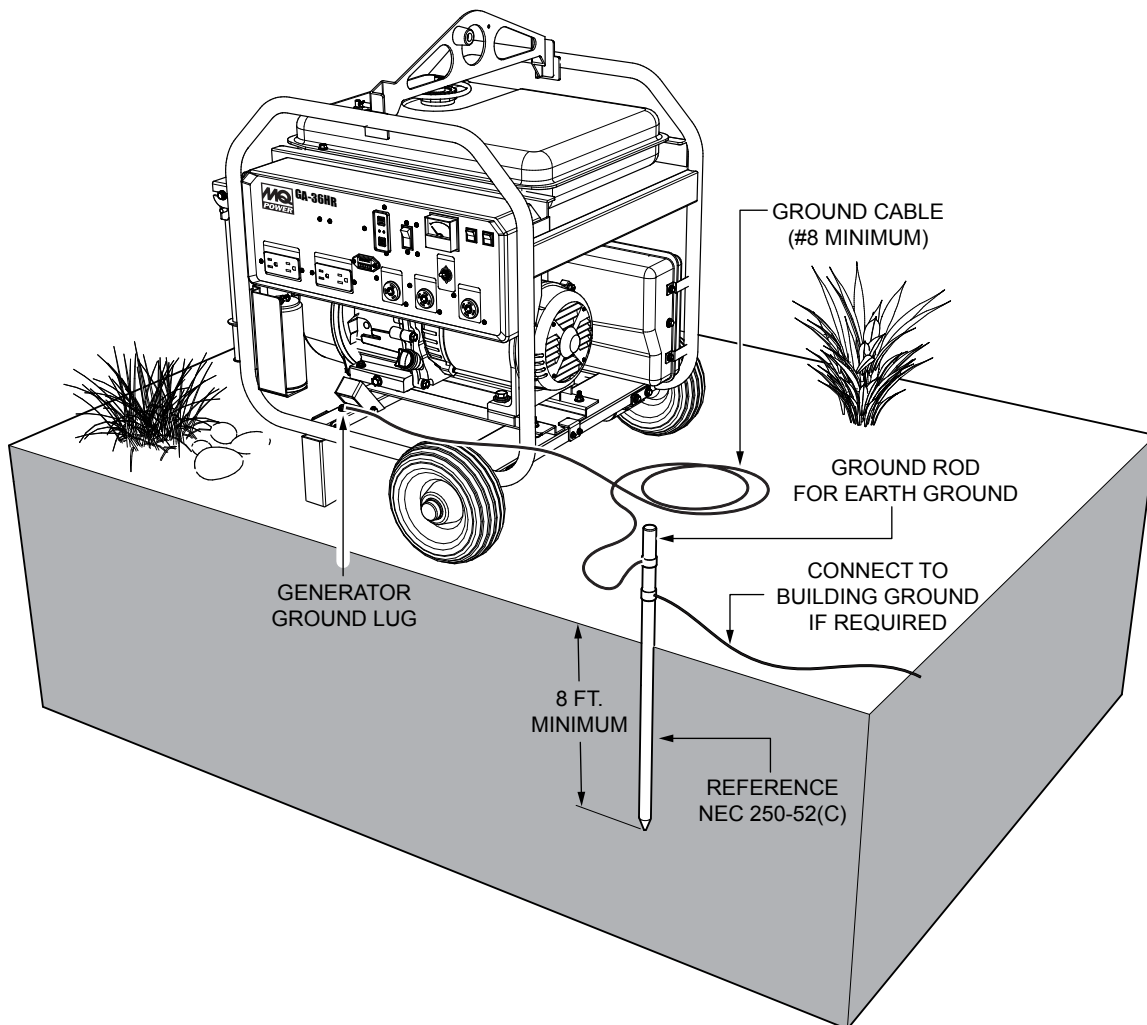



Figure 3. Generator Grounding

OUTDOOR INSTALLATION

If possible install the generator in a area that is free of debris, bystanders, and overhead obstructions. Make sure the generator is on secure level ground so that it cannot slide or shift around.

The installation site must be relatively free from moisture and dust. All electrical equipment should be protected from excessive moisture. Failure to do will result in deterioration of the insulation and will result in short circuits and grounding.

Foreign materials such as dust, sand, lint and abrasive materials have a tendency to cause excessive wear to engine and alternator parts.

 **WARNING**

 Pay close attention to ventilation when operating the generator inside tunnels and caves. The engine exhaust contains noxious elements. Engine exhaust must be routed to a ventilated area

INDOOR INSTALLATION

Exhaust gases from gas engines are extremely poisonous. Whenever an engine is installed indoors the exhaust fumes must be vented to the outside. The engine should be installed at least two feet from any outside wall. Using an exhaust pipe which is too long or too small can cause excessive back pressure which will cause the engine to heat excessively and possibly burn the valves.

PLACEMENT

The generator should always be placed on a flat level surface when it is running. **DO NOT** place the generator on slopes, the possibility exists that the generator could slide.

 **DANGER**

 Electric shock can occur when vibrators are used. Pay close attention to handling when operating vibrators and always use rubber boots and gloves to insulate the body from a short circuit.

GENERATOR GROUNDING

To guard against electrical shock and possible damage to the equipment, it is important to provide a good **EARTH** ground.

Article 250 (Grounding) of the National Electrical Code (NEC) provides guide lines for proper grounding and specifies that the cable ground shall be connected to the grounding system of the building as close to the point of cable entry as practical.

NEC articles 250-64(b) and 250-66 set the following grounding requirements:

1. Use one of the following wire types to connect the generator to earth ground.
 - a. Copper - 10 AWG (5.3 mm²) or larger.
 - b. Aluminum - 8 AWG (8.4 mm²) or larger.
2. When grounding the generator (Figure 3) connect the ground cable between the lock washer and the nut on the generator and tighten the nut fully. Connect the other end of the ground cable to earth ground.
3. NEC article 250-52(c) specifies that the earth ground rod should be buried a minimum of 8 ft. into the ground.

NOTICE

When connecting the generator to any buildings electrical system **ALWAYS** consult with a licensed electrician.

FAMILIARIZATION

Generator

The Multiquip GA3.6HR generator is designed as a portable dual purpose power source for 60 Hz (single phase) lighting facilities, power tools, submersible pumps and other industrial and construction machinery.

The generator is mounted on rubber vibration isolators that have a steel base backplate which is attached to the protective steel pipe carrying frame.

The protective carrying frame is made of steel tubing and fully wraps around the generator to protect against damage. Reference Figure 4, Figure 5 and Figure 8 for the basic controls and indicators for the GA3.6HR generator.

These portable generator are supplied with a electrical control box (panel). To reduce vibration caused by the engine, the control box is also placed on rubber isolators.

Control Panel

The control panel is provided with the following:

- 120V Twist-Lock Output Receptacle (L5-20R)
- 120V Twist-Lock Output Receptacle (L5-30R)
- 120/240V Twist-Lock Output Receptacle (L14-30R)
- 120 VAC GFCI Receptacle (2)
- GFCI Sensing Module
- 15 Amp Main Circuit Breaker.
- AC Voltmeter
- Idle Control Switch
- Full Power Switch
- Operation Switch
- Hour Meter

DANGER

Before connecting this generator to any building's electrical system, a licensed electrician must install an isolation (transfer) switch.

Serious injury or death may result without this transfer switch.

COMPONENTS (GENERATOR)

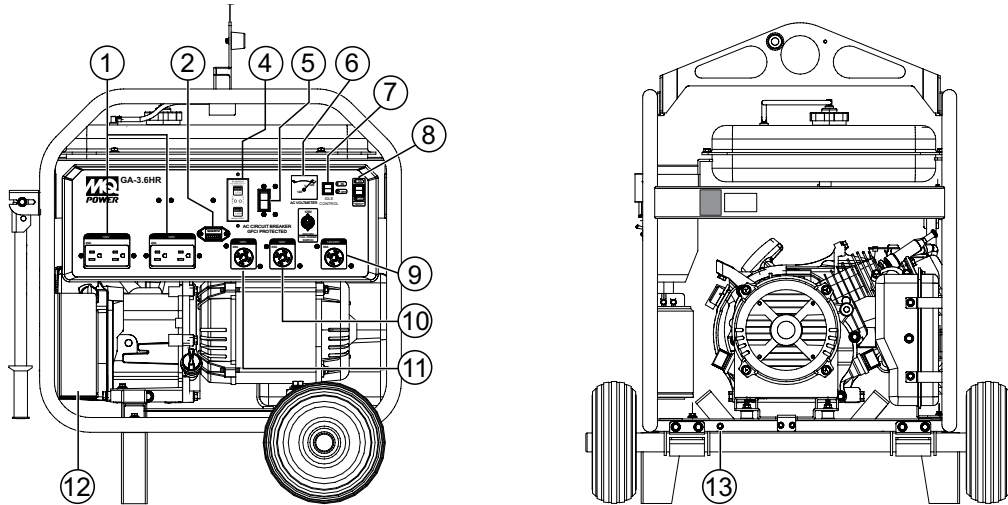

Figure 4. Generator Components

1. **GFCI Duplex Receptacles** – NEMA 5-20R, GFCI receptacle will provide 120V @ 20 amps.
2. **Hour Meter** – Indicates the number hours the generator has been in use.
3. **Lifting Bail Eye** – Attach a rope or chain to this lifting eye when lifting of the generator is required. Never stand underneath the generator while it is being lifted. Place lifting bail in down position when not in use.
4. **GFCI Sensing Module** – Interrupts power when a ground fault exist.
5. **Main Breaker** – This 2-pole, 15 amp circuit breaker protects the generator from short circuiting or overloading. When starting the generator always have the circuit breaker placed in the "OFF" position.
6. **AC-Voltmeter** – This voltmeter indicates (with a mark) the rated 60 Hz (single-phase) output voltage. In addition the voltmeter can also be used as a diagnostic tool. If the voltmeter indicator (needle) is below the rated voltage, engine problems may exist (low/high RPM's). To prevent damage to the generator or power tools turn the generator **OFF** and consult your authorized Multiquip service dealer.
7. **Idle Control Switch** – The generator is provided with an automatic idle control device for noise suppression and reduced fuel consumption.

The automatic idle control automatically engages under a no-load condition. With the automatic idle control switched "ON", the engine revolutions will automatically drop to about 2500 rpm (low-speed operation) within 3 seconds after the load stops. When the operation is resumed, the engine speed is automatically increased to about 3600 rpm (high-speed operation) as soon as the load is connected.
8. **Operation Switch** – Place switch in the "ON" position (up) for normal operation. To turn-off the generator, place the operation switch in the "OFF" position (down)
9. **120/240V Output Receptacle** – NEMA L14-30R twist-lock receptacle will provide 240V, 60 Hz @ 13.3 amps, or 120V @ 26.7 amps (X2) 60 Hz. Depending on the position of the full power switch.
10. **120V Output Receptacle** – NEMA L5-30R twist-lock receptacle will provide 120V, 30 amps, 60 Hz.
11. **120V Output Receptacle** – NEMA L5-20R twist-lock receptacle will provide 120V, 20 amps, 60 Hz.
12. **Charcoal Canister** – A container filled with activated charcoal that traps gasoline vapors emitted by the fuel system.
13. **Ground** – This ground connection point should be connect to a good earth ground (ground rod).

COMPONENTS (GENERATOR)

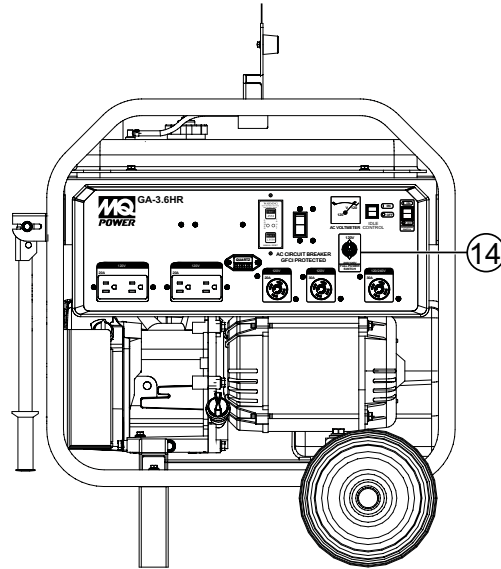

Figure 5. Full Power Switch

14. **Full Power Switch** – The generator is provided with a full power switch. Figure 6 and Figure 7 show simplified wiring diagrams of the dual voltage system.

When the full power switch is in the 120 volt (up) position, you can access the full rated power of the generator at 120 volts from the GFCI duplex receptacle and the 120V twist-lock receptacle, or a combination of both receptacles as long as the total load does not exceed the generating set capacity.

When the switch is in the 240 volt (down) position, you can access half of the rated power of the generating set at 120 volts from the GFCI duplex receptacle and up to half of the rated power of the set at 120 volts from 120V twist-lock receptacle; or full rated power of the set at 240 volts from the 240V twist-lock receptacle.

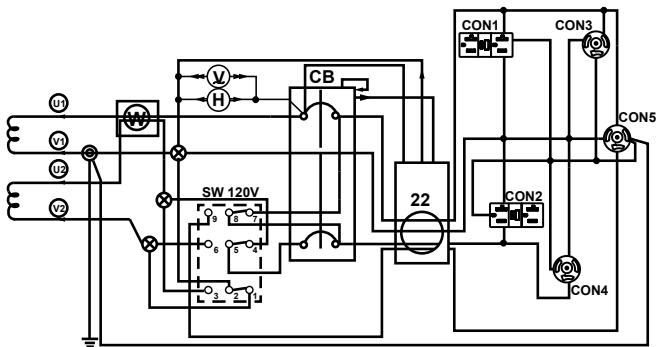

Figure 6. 120V Full Power Switch Simplified Diagram (Up Position)

NOTICE

When the **full power switch** is in the 120V position, the 240V twist-lock receptacle **cannot be used**.

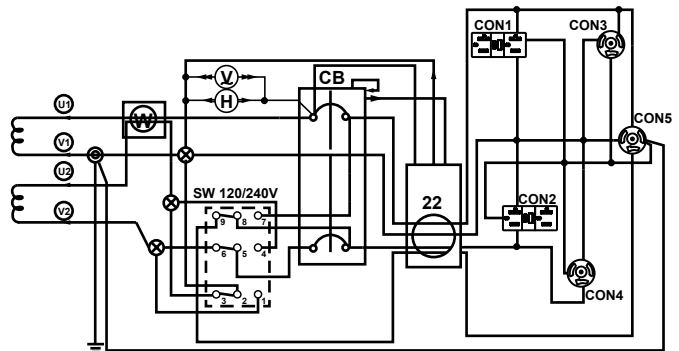

Figure 7. 240/120V Full Power Switch Simplified Diagram (Down Position)

NOTICE

When using a combination of receptacles, total load should not exceed the rated capacity of the generator.

COMPONENTS (GENERATOR)

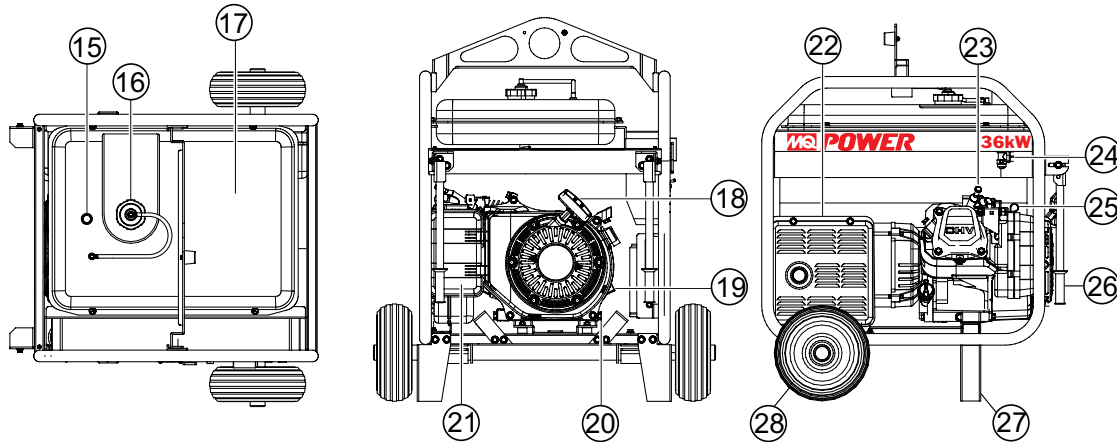

Figure 8. Generator Components (Continued)

15. **Fuel Gauge** – This gauge is located on top of the fuel tank. Read this gauge to determine when fuel is low.
16. **Fuel Tank Cap** – Remove this cap to add unleaded gasoline to the fuel tank. Replenish with clean unleaded gasoline. Make sure cap is tightened securely. **DO NOT** over fill.
17. **Fuel Tank** – Capacity is 5 gallons (19 liters). Fill with unleaded gasoline.
18. **Recoil Starter (pull rope)** – Manual-starting method. Pull the starter grip until resistance is felt, then pull briskly and smoothly.
19. **Engine Oil Filler Cap** – Remove this cap/dipstick when the adding of engine oil is required. See Table 2 for recommended type engine oil.
20. **Engine Oil Drain Plug** – Remove this drain plug when draining of the oil from the engine crankcase is required. Fill with recommended type oil as listed in Table 4.
21. **Air Cleaner** – Prevents dirt and other debris from entering the fuel system. Remove wing-nut on top of air filter cannister to gain access to filter element. **NEVER** run the engine without an air cleaner.
22. **Muffler/Heat Shield** – Used to reduce noise and emissions. **NEVER** touch this heat shield when the generator is in use. Always allow time for engine to cool before servicing.
23. **Spark Plug** – Provides spark to the ignition system. Set spark plug gap to 0.6 - 0.7 mm (0.028 - 0.031 inch) Clean spark plug once a week.
24. **Fuel Cock Lever** – Turn this lever downward (ON) to start the flow of fuel into the carburetor. Turn upward to stop (OFF) the flow of fuel.
25. **Choke Lever** – Used for starting the engine. Close the choke lever when starting a cold engine or in cold weather conditions. The choke enriches the fuel mixture. Open the choke lever if starting a warm engine or in warm weather conditions.
26. **Transport Handle** – When transporting of the generator is required, lift up on each handle and engage locking pin. Part of wheel kit assembly
27. **Support Stand** – Supports the generator, part of wheel kit assembly
28. **Foam-Filled Tires** – Provided for ease of transport. Replace with only recommended tires.

NOTICE

This **HONDA** engine is equipped with a low oil shutdown capability. A built in sensor will automatically turn off the engine should the oil level fall below a safe operating condition. Make sure the generators is placed on level ground. Placing the generators on level ground will ensure that the low oil sensor will function properly.

GENERAL INSPECTION PRIOR TO OPERATION

Ground Power Tools

When using power tools or electrical equipment requiring AC power from the generator, make sure power tool cord has a ground pin or is double insulated as shown in Figure 9.

NOTICE

Double-insulated power tools and small appliances have specially insulated housings that eliminate the need for a ground pin. These types of double-insulated power cords are designed so that no part of the device will be electrically live even if the internal insulation fails.

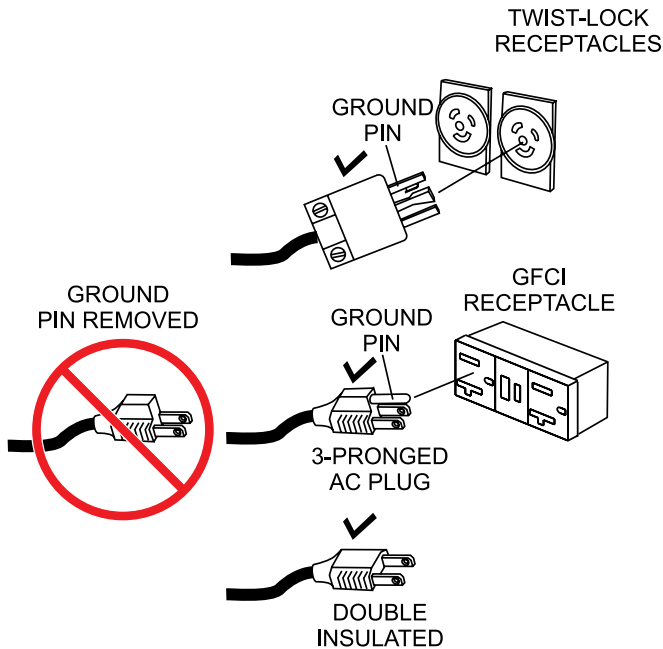

Figure 9. Ground Pin

Extension Cable

When electric power is to be provided to various tools or loads at some distance from the generator, extension cords are normally used. Cables should be sized to allow for distance in length and amperage so that the voltage drop between the generator and point of use (load) is held to a minimum. Use the cable selection chart (Table 4) as a guide for selecting proper cable size.

DANGER

NEVER use power tools or equipment that do not have a ground capability, the possibility exists of electrocution, electrical shock or burn, which can cause severe bodily harm or even **DEATH!**

Current In Amperes	Load In Watts		Maximum Allowable Cable Length			
	120 Volts	240 Volts	#10 Wire	#12 Wire	#14 Wire	#16 Wire
2.5	300	600	1000 ft.	600 ft.	375 ft.	250 ft.
5	600	1200	500 ft.	300 ft.	200 ft.	125 ft.
7.5	900	1800	350 ft.	200 ft.	125 ft.	100 ft.
10	1200	2400	250 ft.	150 ft.	100 ft.	
15	1800	3600	150 ft.	100 ft.	65 ft.	
20	2400	4800	125 ft.	75 ft.	50 ft.	

CAUTION: Equipment damage can result from low voltage.

Before Starting

NOTICE

ALWAYS place the main circuit breaker in the **OFF** position prior to starting the engine.

1. Read safety instructions at the beginning of manual.
2. Clean the generator, removing dirt and dust, particularly the engine cooling air inlet, carburetor and air cleaner.
3. Check the air filter for dirt and dust. If air filter is dirty, replace air filter with a new one as required.
4. Check carburetor for external dirt and dust. Clean with dry compressed air.
5. Check fastening nuts and bolts for tightness.

Engine Oil Check

1. To check the engine oil level, place the generator on secure level ground with the engine stopped.
2. Remove the filler dipstick from the engine oil filler hole (Figure 10) and wipe clean.

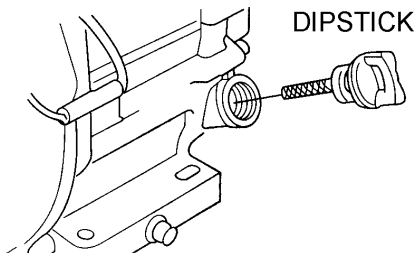

Figure 10. Engine Oil Dipstick Removal

3. Insert and remove the dipstick without screwing it into the filler neck. Check the oil level shown on the dipstick.

4. If the oil level is low (Figure 11), fill to the edge of the oil filler hole with the recommended oil type (Table 5). Maximum oil capacity is 1.16 quarts (1.1 liters).

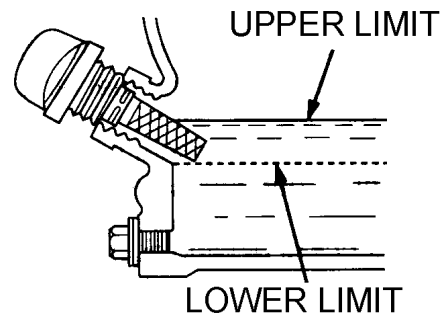

Figure 11. Engine Oil Dipstick (Oil Level)

Table 5. Oil Type

Season	Temperature	Oil Type
Summer	25°C or Higher	SAE 10W-30
Spring/Fall	25°C~10°C	SAE 10W-30/20
Winter	0°C or Lower	SAE 10W-10

Fuel Check

1. Close the fuel cock before filling the fuel tank.
2. Remove the fuel cap located on top of fuel tank.
3. Read the fuel gauge located on top of the fuel tank (Figure 12) to determine if the fuel level is low. If fuel is low, replenish with clean unleaded fuel.

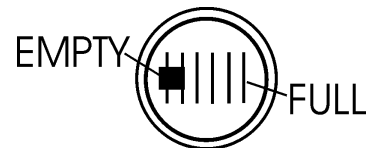

Figure 12. Fuel Gauge

4. When refueling, be sure to use a strainer for filtration. **DO NOT** top-off fuel. **DO NOT** fill the tank beyond capacity. Wipe up any spilled fuel **immediately!**

This section is intended to assist the operator with the initial start-up of the portable generator. It is extremely important that this section be read carefully before attempting to use the generator in the field.

Before Starting the Engine

NOTICE

This generator is equipped with a GFCI sensing module. The purpose of this module is to sense a ground fault during operation of the generator and open the main circuit breaker once the ground fault has been detected.

Multiquip recommends that the GFCI sensing module be tested before each use of the generator. Reference the maintenance section of this manual for the testing of the GFCI sensing module.

1. Be sure to disconnect all electrical loads from the generator prior to starting the engine.
2. **NEVER** start the engine with the main circuit breaker in the **ON** position. Always place circuit breaker (Figure 13) in the **OFF** position before starting.

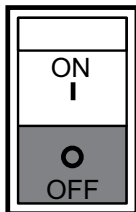

Figure 13. Main Circuit Breaker (OFF)

Starting the Engine (Recoil Start)

1. Place the engine fuel valve lever (Figure 14) in the **ON** position.

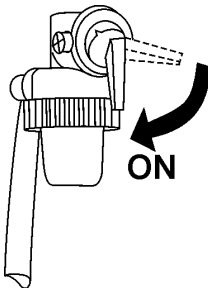

Figure 14. Engine Fuel Valve Lever (ON)

2. Place the choke lever (Figure 15) in the **CLOSED** position if starting a cold engine.

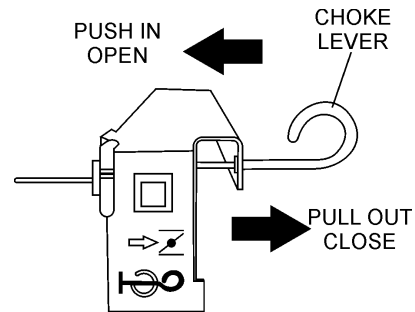

Figure 15. Choke Lever

3. Place the choke lever (Figure 15) in the **OPEN** position if starting a warm engine or the temperature is warm.
4. Place the generator's operation switch (Figure 16) in the **ON** position.

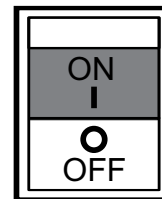

Figure 16. Operation Switch (ON)

5. If your generator is a recoil start only (no battery), grasp the starter grip (Figure 17) and slowly pull it out. The resistance becomes the hardest at a certain position, corresponding to the compression point. Pull the starter grip briskly and smoothly for starting.

Proceed to step 6 if your unit is an electric start model (battery installed).

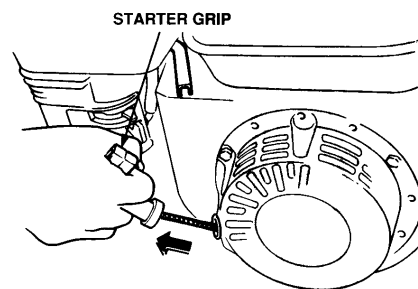

Figure 17. Starter Grip

NOTICE

DO NOT pull the starter rope all the way to the end.

DO NOT release the starter rope after pulling. Allow it to rewind as soon as possible..

- If the engine has started, slowly return the choke lever (Figure 15) to the **OPEN** position. If the engine has not started repeat steps 1 through 6.
- Before the generator is placed into operation, run the engine for 3-5 minutes. Check for abnormal smells, fuel leaks, and noises that would associate with loose components.
- Place idle control switch (Figure 18) in the **OFF** position. This will allow the engine speed to run at about 3600 RPM's.
- Place main circuit breaker (Figure 20) in the **ON** position.

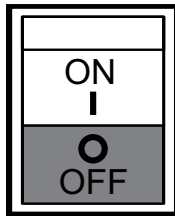

Figure 18. Idle Control Switch (OFF)

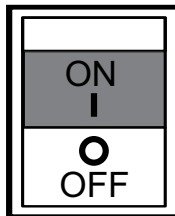

Figure 19. Idle Control switch (ON)

- Place the full power switch (Figure 21) in the 120V position (up).

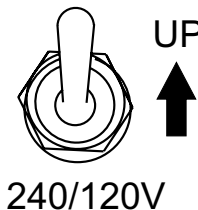

Figure 21. Full Power Switch 120V Position (Up)

NOTICE

When the full power switch is in the 120V position, the 240V twist-lock receptacle cannot be used.

NOTICE

Placing the idle control switch in the **OFF** position (Figure 18) allows the engine to operate at a maximum speed of about 3600 RPM's.

When the idle control switch (Figure 19) is placed in the up position (**ON**), the generator will run at idle speed (2500 RPM's) until a load is applied, at that time the engine speed will increase to 3600 RPM's as long as a load is being applied.

When the load is not in use, the engine speed will drop back to the idle mode after about 3 seconds.

OPERATION

11. Read voltmeter on front panel of generator (Figure 22) and verify that 120 VAC is displayed. Using an external voltmeter as shown in Figure 22, verify that 120 VAC is present at the 120V twist-lock and GFCI duplex receptacles.

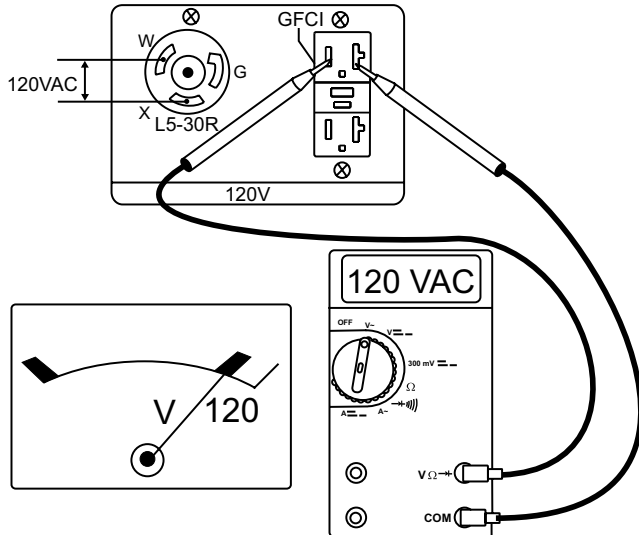

Figure 22. 120V Twist-Lock/GFCI Receptacles

12. Place the full power switch (Figure 23) in the 240/120V position (down).

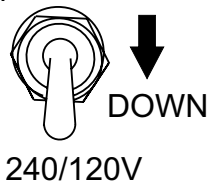

Figure 23. Full Power Switch 240/120V Position (Down)

13. Read voltmeter on front panel of generator (Figure 24) and verify that 240 VAC is displayed. Using an external voltmeter as shown in Figure 24, verify that 240 VAC is present at the 120/240V, L14-30R twist-lock receptacle.

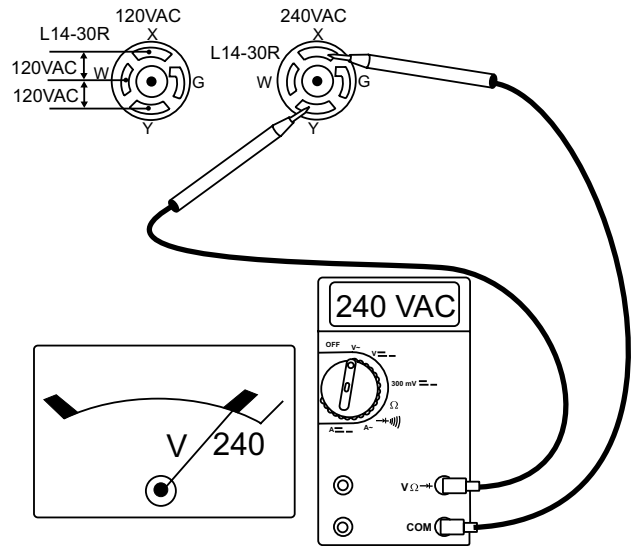

Figure 24. 120/240V L14-30R Receptacle

NOTICE

When using a combination of dual receptacles, total load should not exceed the rated capacity of the generator.

14. Connecting of loads (power tools, lighting etc.) to the generator receptacles can now be done.

Stopping the Engine (Normal Shutdown)

1. Place main circuit breaker (Figure 25) in the **OFF** position.

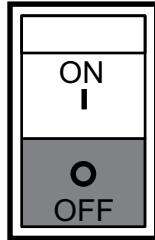

Figure 25. Main Circuit Breaker (OFF)

2. Place idle control switch (Figure 26) in the **ON** position.

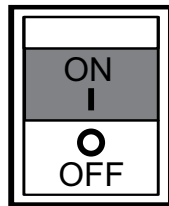

Figure 26. Idle Control switch (ON)

3. Let engine run at idle with no load for 2-3 minutes.
4. To shut-down the engine, place the generator's operation switch (Figure 27) in the **OFF** position.

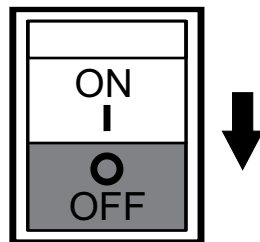

Figure 27. Operation Switch (OFF)

5. Place engine fuel valve lever (Figure 28) in the **OFF** position.

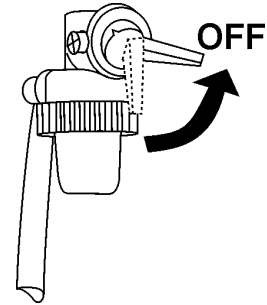

Figure 28. Engine Fuel Valve Lever (OFF)

6. Remove all loads from the generator.

Emergency Shutdown

1. Place operation switch (Figure 29) in the **OFF** position.

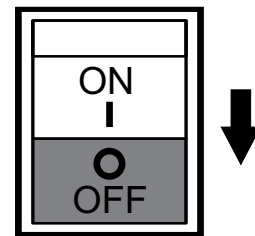

Figure 29. Operation Switch (Emergency)

PREPARATION FOR LONG TERM STORAGE

Generator Storage

For storage of the generating set for over 30 days, the following is required:

- Drain the fuel tank completely, or add STA-BIL to the fuel.
- Run the engine until the gasoline in the carburetor is completely consumed.
- Completely drain the oil from the crankcase and refill with fresh oil.
- Remove the spark plug, pour 2 or 3 cc of SAE 30 oil into the cylinder and crank slowly to distribute the oil.
- Slowly rotate the engine a few times with the starter rope and install a new plug.
- Pull out the starter rope slowly and stop at the compression point.
- Clean all external parts of the generating set with a cloth.
- Cover the generating set and store in a clean, dry place.

MAINTENANCE

Use Table 6 as a general maintenance guideline when servicing your engine. For more detail engine maintenance information, refer to the engine owner's manual supplied with your engine.

Table 6. Engine Maintenance Schedule							
DESCRIPTION (3)	OPERATION	BEFORE	FIRST MONTH OR 10 HRS.	EVERY 3 MONTHS OR 25 HRS.	EVERY 6 MONTHS OR 50 HRS.	EVERY YEAR OR 100 HRS.	EVERY 2 YEARS OR 200 HRS.
Engine Oil	CHECK	X					
	CHANGE		X		X	X	X
Air Cleaner	CHECK	X	X				
	CHANGE			X (1)			
Charcoal Canister (4)	REPLACE						
All Nuts & Bolts	RETIGHTEN IF NECESSARY	X					
Spark Plug	CHANGE				X		
	REPLACE						X
Cooling Fins	CHECK				X		
Spark Arrester	CLEAN					X	
Fuel Tank	CLEAN					X	
Fuel Strainer	CHECK				X	X	
Idle Speed	CHECK-ADJUST					X (2)	
Valve Clearance	CHECK-ADJUST			X		X	X (2)
Fuel lines	CHECK	Every 2 years, replace if necessary (2)					

(1) Service more frequently when used in **DUSTY** areas.

(2) These items should be serviced by your service dealer, unless you have the proper tools and are mechanically proficient. Refer to the HONDA Shop Manual for service procedures.

(3) For commercial use, log hours of operation to determine proper maintenance intervals.

(4) Charcoal canister is maintenance free (non-servicable). Replace only if damaged.

MAINTENANCE

Perform the scheduled maintenance procedures as defined by Table 6 on the previous page:

Daily

Thoroughly remove dirt and oil from the engine and control area. Clean or replace the air cleaner elements as necessary. Check and retighten all fasteners as necessary.

Wiring

Inspect the entire generator for bad or worn electrical wiring or connections. If any wiring or connections are exposed (insulation missing) replace wiring immediately.

Piping and Hose Connection

Inspect all piping, oil hose, and fuel hose connections for wear and tightness. Tighten all hose clamps and check fuel or leaks. If any hose (fuel or oil) lines are defective replace them immediately.

Fuel Strainer

1. Thoroughly clean the area around the fuel cap.
2. Remove the fuel cap from the fuel tank.
3. Next, remove, inspect and clean the fuel strainer (Figure 30) with solvent.

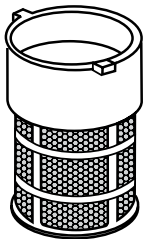

Figure 30. Fuel Strainer

Spark Plug

1. Remove and clean the spark plug (Figure 31), then adjust the spark gap to 0.024 ~0.028 inch (0.6~0.7 mm). This unit has electronic ignition, which requires no adjustments.

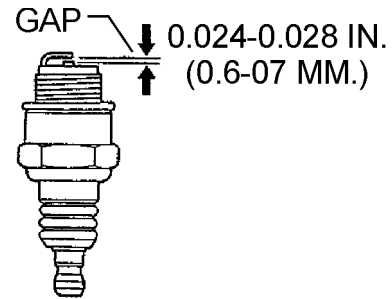

Figure 31. Spark Plug Gap

ENGINE OIL

2. Drain the engine oil when the oil is warm as shown in Figure 32.
3. Remove the oil drain bolt and sealing washer and allow the oil to drain into a suitable container.
4. Replace engine oil with recommended type oil as listed in Table 4. For engine oil capacity, see Table 2 (engine specifications). **DO NOT** overfill.
5. Install drain bolt with sealing washer and tighten securely.

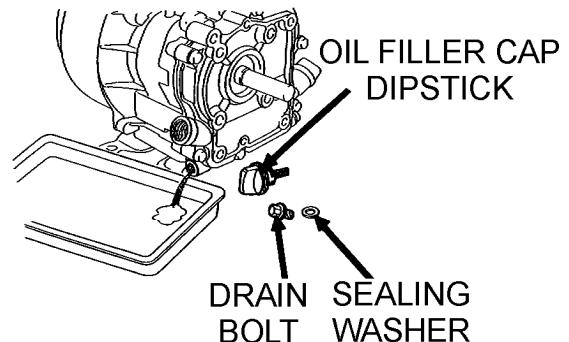

Figure 32. Draining Engine Oil

ENGINE AIR CLEANER

! DANGER



DO NOT use gasoline as a cleaning solvent, the possibility exists of fire or explosion which can cause damage to the equipment and severe bodily harm or even **DEATH!**

1. Remove the air cleaner cover and foam filter element as shown in Figure 33.

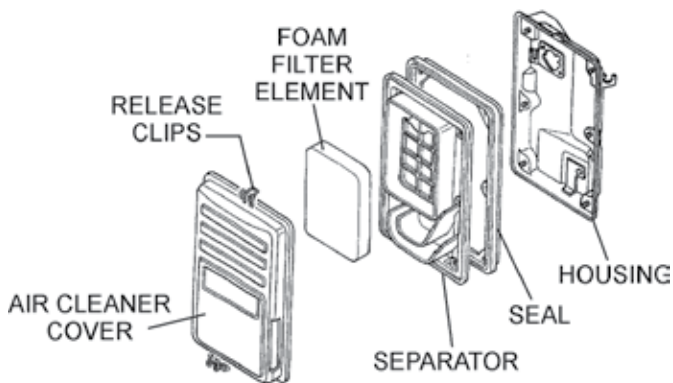

Figure 33. Engine Air Cleaner

2. Clean foam element (Figure 34) in warm, soapy water or non-flammable solvent. Rinse and dry thoroughly.
3. Next, dip the element in clean engine oil and completely squeeze out the excess oil from the element before installing.

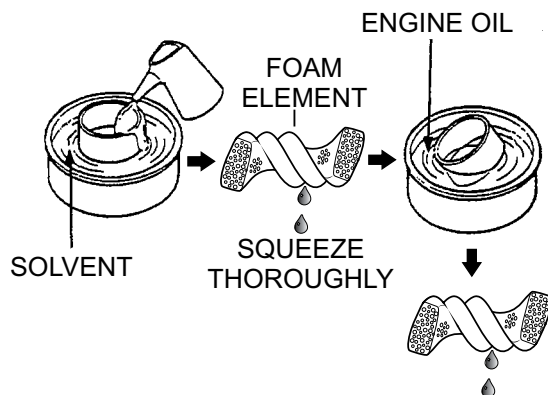

Figure 34. Cleaning Foam Element

SPARK ARRESTER CLEANING

Clean the spark arrester every 6 months or 100 hours.

1. Remove the muffler protector retaining bolts (Figure 35), then remove muffler protector.
2. Next, remove tapping screw that secures spark arrester to muffler, then remove spark arrester.

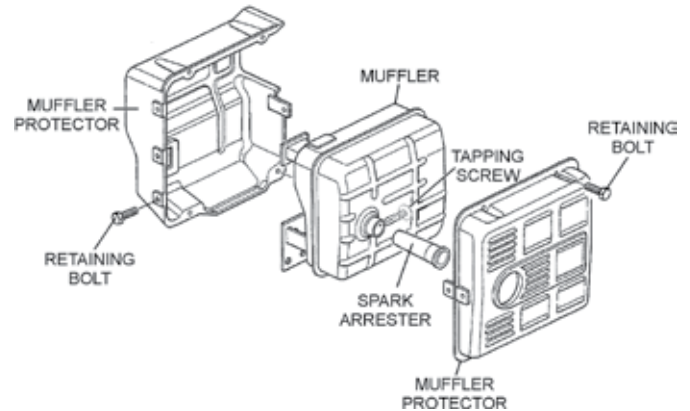

Figure 35. Spark Arrester Removal

3. Carefully remove carbon deposits from the spark arrester screen (Figure 36) with a wire brush.

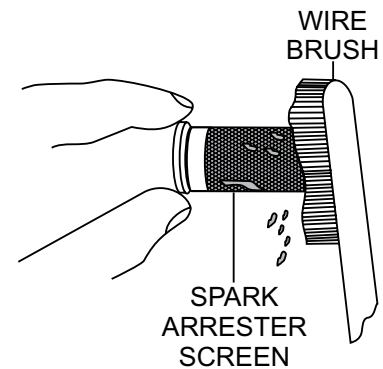

Figure 36. Cleaning The Spark Arrester

4. If the spark arrester is damaged and has breaks or holes, replace with a new one.
5. Reinstall the spark arrester and muffler protector in reverse order of disassembly.

TESTING THE GFCI MODULE

If tripping of the *main* circuit breaker persists after a load is replaced with a known good one (no short circuit), perform this test with no load.

1. Start the generator as outlined in the start up procedure in this manual.
2. Place the main circuit breaker (Figure 37) in the **ON** position.

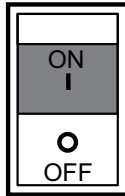

Figure 37. Circuit Breaker ON (GFCI Test)

3. On the GFCI module (Figure 38), verify that the **green** POWER LED is **ON**.

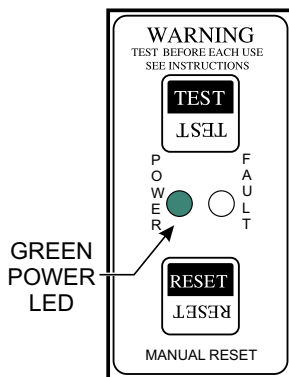

Figure 38. GFCI Module (Green LED ON)

4. Also verify that the AC voltmeter is registering a voltage reading as indicated by Figure 43.

5. Next, press the **TEST** button on the GFCI module and verify that the **green** POWER LED turns **OFF** and the **red** FAULT LED turns **ON**.

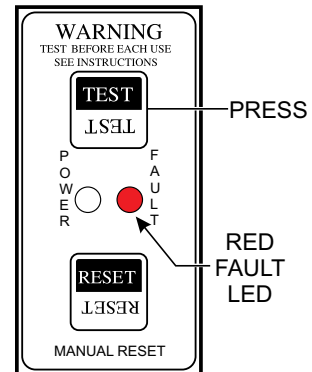

Figure 39. GFCI Module (Red/Fault LED ON)

6. Also verify that the main circuit breaker switch trips to the **OFF** position.

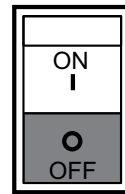

Figure 40. Circuit Breaker OFF (GFCI Test)

7. Verify that the AC voltmeter (Figure 41) on the generator reads zero volts.

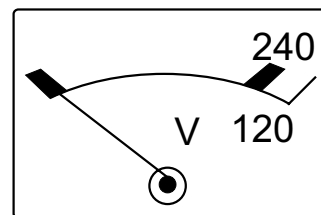

Figure 41. AC Voltmeter (Zero Volts)

- To restore power, press the RESET button (Figure 42) on the GFCI module and verify that the **red** FAULT LED turns **OFF** and the green POWER LED should turn **ON**

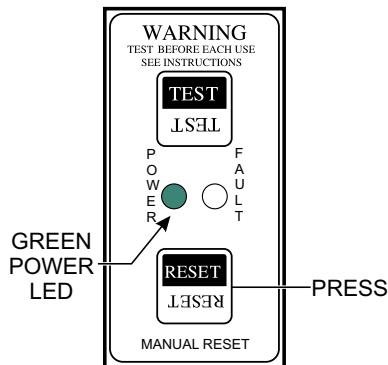

Figure 42. GFCI Module (Green LED ON Reset)

- Verify that the AC voltmeter is registering a voltage reading as indicated by Figure 43.

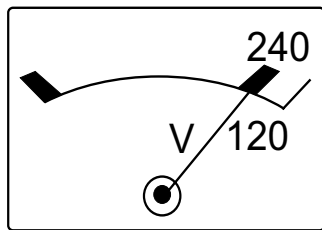

Figure 43. AC Voltmeter (120/240V)

NOTICE

It is recommended that the GFCI unit be tested when the generator is initially taken out of the box. Then, the generator should be tested daily at startup.

CAUTION

The GFCI module is designed to interrupt power when a ground fault exists to prevent injuries and shock hazards. **DO NOT** operate the generator if this test fails. Consult a qualified electrician for repair or replacement of the GFCI module.

GENERATOR WIRING DIAGRAM

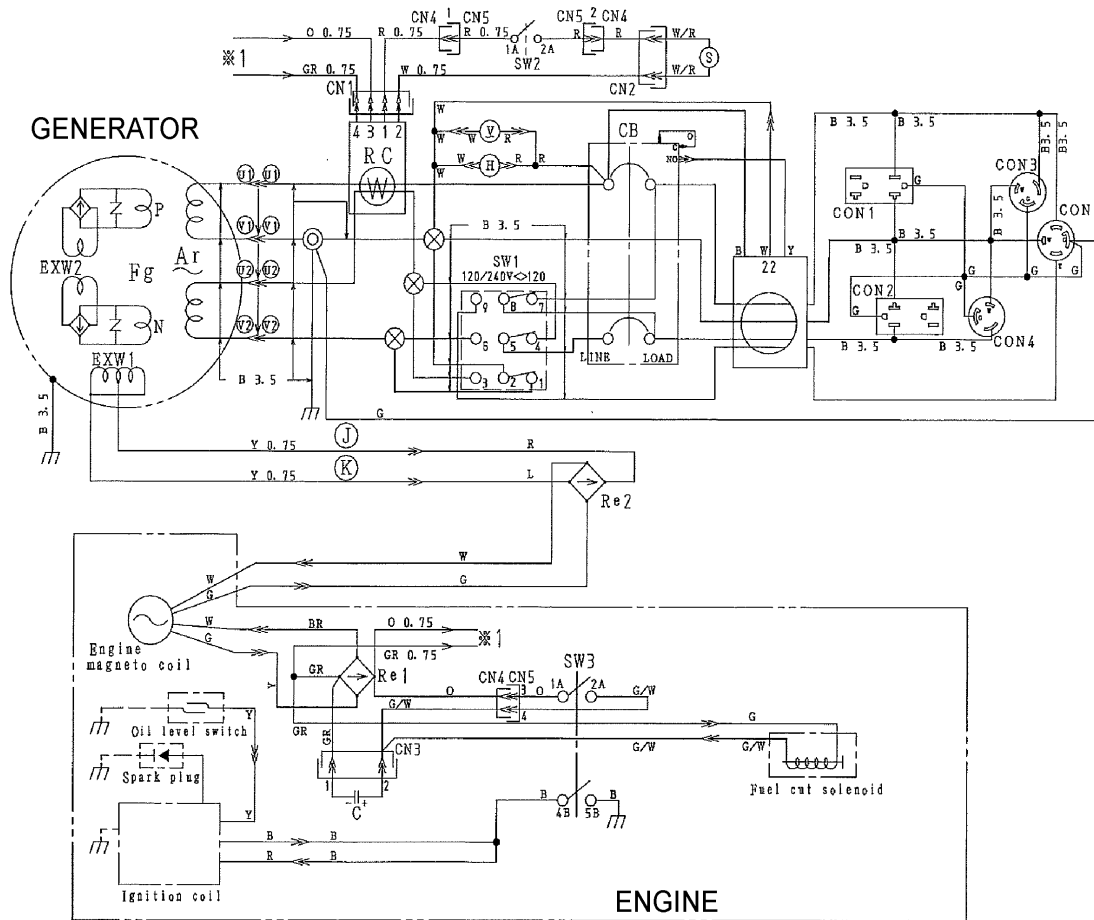

COLOR CODE	
WIRE COLOR	WIRE COLOR
B BLACK	R RED
L BLUE	W WHITE
BR BROWN	Y YELLOW
G GREEN	LB LIGHT BLUE
GR GRAY	LG LIGHT GREEN
V VIOLET	O ORANGE
P PINK	

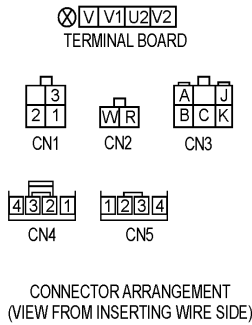

SYMBOL	DESIGNATION
Ar	ARMATURE WINDING
Fg-P, N	ROTOR ASSEMBLY
Ex W1	EXCITATION WINDING
Ex W2	EXCITATION WINDING
V	AC VOLTMETER 120/240V
RE 1-2	RECTIFIER
CB	CIRCUIT BREAKER 23A
CON 1,2	RECEPTACLE 5-20R GFCI 20A, 125V
CON 3	RECEPTACLE L5-20R 20A 125V
CON 4	RECEPTACLE L5-30R 30A, 125/250V
CON 5	RECEPTACLE L14-30R 30A, 125/250V
SW1	FULL POWER SWITCH
SW2	IDLE CONTROL SWITCH
SW3	OPERATION SWITCH
RC	IDLE CONTROL DEVICE
S	IDLE CONTROL SOLENOID
C	CAPACITOR
22	GFCI SENSING MODULE
⊗	TERMINAL BOARD
H	HOUR METER

TROUBLESHOOTING (ENGINE)

Troubleshooting (Engine)		
Symptom	Possible Problem	Solution
Difficult to start, fuel is available, but no spark at spark plug.	Spark plug bridging?	Check gap, insulation or replace spark plug.
	Carbon deposit on spark plug?	Clean or replace spark plug.
	Short circuit due to deficient spark plug insulation?	Check spark plug insulation, replace if worn.
	Improper spark plug gap?	Set to proper gap.
	Spark plug is red?	Check transistor ignition unit.
	Spark plug is bluish white?	If insufficient compression, repair or replace engine. If injected air leaking, correct leak. If carburetor jets clogged, clean carburetor.
	No spark present at tip of spark plug?	Check transistor ignition unit is broken, and replace defective unit. Check if voltage cord cracked or broken and replace. Check if spark plug if fouled and replace.
	No oil?	Add oil as required.
	Oil pressure alarm lamp blinks upon starting? (if applicable)	Check automatic shutdown circuit, "oil sensor". (if applicable)
Difficult to start, fuel is available, and spark is present at the spark plug.	ON/OFF switch is shorted?	Check switch wiring, replace switch.
	Ignition coil defective?	Replace ignition coil.
	Improper spark gap, points dirty?	Set correct spark gap and clean points.
	Condenser insulation worn or short circuiting?	Replace condenser.
	Spark plug wire broken or short circuiting?	Replace defective spark plug wiring.
Difficult to start, fuel is available, spark is present and compression is normal.	Wrong fuel type?	Flush fuel system, replace with correct type of fuel.
	Water or dust in fuel system?	Flush fuel system.
	Air cleaner dirty?	Clean or replace air cleaner.
	Choke open?	Close choke.
Difficult to start, fuel is available, spark is present and compression is low.	Suction/exhaust valve stuck or protruded?	Reseat valves.
	Piston ring and/or cylinder worn?	Replace piston rings and/or piston.
	Cylinder head and/or spark plug not tightened properly?	Torque cylinder head bolts and spark plug.
	Head gasket and/or spark plug gasket damaged?	Replace head and spark plug gaskets.
No fuel present at carburetor.	No fuel in fuel tank?	Fill with correct type of fuel.
	Fuel cock does not open properly?	Apply lubricant to loosen fuel cock lever, replace if necessary.
	Fuel filter/lines clogged?	Replace fuel filter.
	Fuel tank cap breather hole clogged?	Clean or replace fuel tank cap.
	Air in fuel line?	Bleed fuel line.

TROUBLESHOOTING (ENGINE)

Troubleshooting (Engine) - continued		
Symptom	Possible Problem	Solution
Weak in power, compression is proper and does not misfire.	Air cleaner dirty?	Clean or replace air cleaner.
	Improper level in carburetor?	Check float adjustment, rebuild carburetor.
	Defective spark plug?	Clean or replace spark plug.
	Improper spark plug?	Set to proper gap.
Weak in power, compression is proper but misfires.	Water in fuel system?	Flush fuel system and replace with correct type of fuel.
	Dirty spark plug?	Clean or replace spark plug.
	Ignition coil defective?	Replace ignition coil.
Engine overheats.	Spark plug heat value incorrect?	Replace with correct type of spark plug.
	Wrong type of fuel?	Replace with correct type of fuel.
	Cooling fins dirty?	Clean cooling fins.
	Intake air restricted?	Clear intake of dirt and debris. Replace air cleaner elements as necessary.
	Oil level too low or too high?	Adjust oil to proper level.
Rotational speed fluctuates.	Governor adjusted incorrectly?	Adjust governor.
	Governor spring defective?	Replace governor spring.
	Fuel flow restricted?	Check entire fuel system for leaks or clogs.
Recoil starter malfunctions. (if applicable)	Recoil mechanism clogged with dust and dirt?	Clean recoil assembly with soap and water.
	Spiral spring loose?	Replace spiral spring.
Starter malfunctions.	Loose, damaged wiring?	Ensure tight, clean connections on battery and starter.
	Battery insufficiently charged?	Recharge or replace battery.
	Starter damaged or internally shorted?	Replace starter.
Burns too much fuel.	Over-accumulation of exhaust products?	Check and clean valves. Check muffler and replace if necessary.
	Wrong spark plug?	Replace spark plug with manufacturer's suggested type.
Exhaust color is continuously "white".	Lubricating oil is wrong viscosity?	Replace lubricating oil with correct viscosity.
	Worn rings?	Replace rings.
Exhaust color is continuously "black".	Air cleaner clogged?	Clean or replace air cleaner.
	Choke valve set to incorrect position?	Adjust choke valve to correct position.
	Carburetor defective, seal on carburetor broken?	Replace carburetor or seal.
	Poor carburetor adjustment, engine runs too rich?	Adjust carburetor.
Will not start, no power with key "ON". (if applicable)	ON/OFF device not activated ON?	Turn on ON/OFF device.
	Battery disconnected or discharged?	Check cable connections. Charge or replace battery.
	Ignition switch/wiring defective?	Replace ignition switch. Check wiring.

TROUBLESHOOTING (GENERATOR)

Troubleshooting (Generator)		
Symptom	Possible Problem	Solution
Low voltage	Engine speed too low?	Raise engine speed to rated RPM.
Low voltage, 3650 RPM (unloaded), 2500 RPM (idle)	AC voltmeter not working?	Replace Ac voltmeter.
	Control box internal wiring malfunction?	Check control box wiring.
	Rotor winding malfunction?	Check or replace rotor.
	Stator winding malfunction?	Check or replace stator.
	Leakage breaker malfunction?	Check or replace CB1.
	Full power switch malfunction?	Check full power switch and full power switch circuit.
Voltage output too high.	Engine speed too high?	Lower engine speed to rated RPM.
Voltage output too high. Engine speed normal 3650 RPM (unloaded), 2500 RPM (idle)	Control box internal wiring malfunction	Check control box wiring.
Circuit breaker will not turn on "NO LOAD"	Defective circuit breaker?	Replace circuit breaker.
Circuit breaker will not turn on "NO LOAD"	Defective circuit breaker?	Replace circuit breaker.
Circuit breaker will turn on "LOADED" but trips immediately.	Overload Condition?	Reduce load or replace breaker.
	Load circuit is shorted?	Check load circuit for short.
Does not accelerate from low to high "NO LOAD"	Stuck solenoid?	Check solenoid.
	Bad Idle control switch?	Check or replace idle control switch.
Does not accelerate from low to high "LOAD ACTIVE"	Idle control switch malfunction?	Check or replace idle control switch.
	Idle control device malfunction?	Check or replace idle control device.
	Control box internal wiring defective?	Check control box wiring.
Does not decelerate but has "VOLTAGE OUTPUT".	Control box wiring malfunction?	Check control box wiring, replace any defective components.
	Defective solenoid?	Check or replace solenoid.
	Idle control device malfunction?	Check or replace idle control device.

EXPLANATION OF CODE IN REMARKS COLUMN

The following section explains the different symbols and remarks used in the Parts section of this manual. Use the help numbers found on the back page of the manual if there are any questions.

NOTICE

The contents and part numbers listed in the parts section are subject to change **without notice**. Multiquip does not guarantee the availability of the parts listed.

SAMPLE PARTS LIST

NO.	PART NO.	PART NAME	QTY.	REMARKS
1	12345	BOLT	1	INCLUDES ITEMS W/%
2%		WASHER, 1/4 IN.		NOT SOLD SEPARATELY
2%	12347	WASHER, 3/8 IN. ...	1	MQ-45T ONLY
3	12348	HOSE	A/R	MAKE LOCALLY
4	12349	BEARING	1	S/N 2345B AND ABOVE

NO. Column

Unique Symbols — All items with same unique symbol (@, #, +, %, or >) in the number column belong to the same assembly or kit, which is indicated by a note in the “Remarks” column.

Duplicate Item Numbers — Duplicate numbers indicate multiple part numbers, which are in effect for the same general item, such as different size saw blade guards in use or a part that has been updated on newer versions of the same machine.

NOTICE

When ordering a part that has more than one item number listed, check the remarks column for help in determining the proper part to order.

PART NO. Column

Numbers Used — Part numbers can be indicated by a number, a blank entry, or TBD.

TBD (To Be Determined) is generally used to show a part that has not been assigned a formal part number at the time of publication.

A blank entry generally indicates that the item is not sold separately or is not sold by Multiquip. Other entries will be clarified in the “Remarks” Column.

QTY. Column

Numbers Used — Item quantity can be indicated by a number, a blank entry, or A/R.

A/R (As Required) is generally used for hoses or other parts that are sold in bulk and cut to length.

A blank entry generally indicates that the item is not sold separately. Other entries will be clarified in the “Remarks” Column.

REMARKS Column

Some of the most common notes found in the “Remarks” Column are listed below. Other additional notes needed to describe the item can also be shown.

Assembly/Kit — All items on the parts list with the same unique symbol will be included when this item is purchased.

Indicated by:

“INCLUDES ITEMS W/(unique symbol)”

Serial Number Break — Used to list an effective serial number range where a particular part is used.

Indicated by:

“S/N XXXXX AND BELOW”

“S/N XXXX AND ABOVE”

“S/N XXXX TO S/N XXX”

Specific Model Number Use — Indicates that the part is used only with the specific model number or model number variant listed. It can also be used to show a part is NOT used on a specific model or model number variant.

Indicated by:

“XXXXX ONLY”

“NOT USED ON XXXX”

“Make/Obtain Locally” — Indicates that the part can be purchased at any hardware shop or made out of available items. Examples include battery cables, shims, and certain washers and nuts.

“Not Sold Separately” — Indicates that an item cannot be purchased as a separate item and is either part of an assembly/kit that can be purchased, or is not available for sale through Multiquip.

SUGGESTED SPARE PARTS

GA3.6HR PORTABLE 60 HZ GENERATOR WITH HONDA GX240RT2EDN2 GASOLINE ENGINE

1 to 3 units

Qty.	P/N	Description
1.....	0430430120.....	CAP FUEL TANK
1.....	0641360030.....	FILTER FUEL
3.....	16950ZB4015.....	FUEL STRAINER
2.....	7895419004.....	RUBBER SUSPENSION
2.....	1665419004.....	RUBBER SUSPENSION
3.....	9807955876.....	SPARK PLUG
1.....	35480ZF6003.....	SWITCH ASSY., OIL ALERT
2.....	28462ZE2W11.....	ROPE, RECOIL
3.....	17211899000.....	ELEMENT AIR CLEANER

NOTICE

Part numbers on this Suggested Spare Parts list may supersede/replace the part numbers shown in the following parts lists.

GA3.6HR — NAMEPLATE AND DECALS ASSY.

OPERATING INSTRUCTIONS

1. Before starting check the oil and fuel level.
2. Switch the circuit breaker to the "OFF" position.
3. Open the fuel valve.
4. Pull the choke knob.
5. Turn the operation switch to the "ON" position.
6. Pull the recoil starter.
7. After the engine starts, gradually push in the choke knob.
8. Run the generator for 3-5 minutes without load.
9. Check for any abnormal noise or smell.
10. Switch the circuit breaker to the "ON" position.
11. When stopping, cut-off the load and allow the unit to cool for 2-3 minutes before stopping engine.
12. Turn the operation switch to the "OFF" position.
13. After the engine completely stops, close the fuel valve.

AB1110010

⚠ DANGER

Using a generator incorrectly **CAN KILL YOU IN MINUTES.**
 Utiliser un générateur à l'improvise **VOUS TUERA EN QUELQUES MINUTES.**

Exhaust contains carbon monoxide, a poison gas you cannot see or smell.
 Les gaz d'échappement contiennent du monoxyde de carbone, un gaz toxique invisible et inodore.

NEVER use in enclosed or partially enclosed areas.

ONLY use outdoors and away from open windows, doors, and vents.
 Utilisation INTERDITE dans un espace clos ou partiellement clos.

⚠ WARNING

Operation of this equipment may create sparks that can start fires around dry vegetation.

A spark arrestor may be required. The operator should contact local fire agencies for laws or regulation relating to fire prevention requirements.

AB1110010

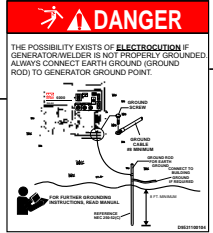

<p>⚠ WARNING</p> <p>To avoid injury, you MUST read and understand operator's manual before using this machine.</p> <p>This machine to be operated by qualified personnel only. Ask for training as needed.</p>	<p>⚠ DANGER</p> <p>Do not touch metal terminals or internal wiring while unit is operating. If you are not a qualified technician, call a service technician.</p> <p>ELECTRICAL SHOCK HAZARD</p>	<p>CAUTION</p> <p>OPERATE AT 3600 RPM ONLY (FULL THROTTLE)</p> <p>DAMAGE MAY RESULT IF OPERATED AT LOWER SPEEDS</p>
	<p>⚠ WARNING</p> <p>Only operate machine in well-ventilated areas. DO NOT inhale exhaust gases.</p> <p>DANGEROUS GAS</p> <p>Only qualified personnel should install, use or service this equipment.</p>	<p>⚠ WARNING</p> <p>BEFORE DISCONNECTING TOOLS</p> <p>OPERATE AT 3600 RPM ONLY (FULL THROTTLE). DO NOT OPERATE AT LOWER SPEEDS. ALWAYS USE PROPER LOCKING AND UNLOCKING PROCEDURES. ALWAYS USE THE LOCKING AND UNLOCKING PROCEDURES TO PREVENT ACCIDENTS.</p> <p>BEFORE REPAIR OR MAINTENANCE, ALWAYS DISCONNECT THE MAIN POWER SUPPLY TO THE EQUIPMENT. ALWAYS USE THE LOCKING AND UNLOCKING PROCEDURES TO PREVENT ACCIDENTS.</p>

AB1110010

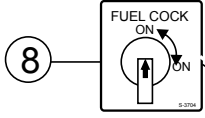
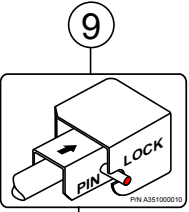

AIR CLEANER MAINTENANCE

- CLEAN ELEMENT EVERY 50 HOURS (EVERY 10 HOURS UNDER DUSTY CONDITIONS). WASH IN HIGH FLASH-POINT SOLVENT. SQUEEZE DRY. THE DIP IN CLEAN ENGINE OIL AND SQUEEZE OUT EXCESS OIL.

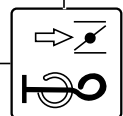
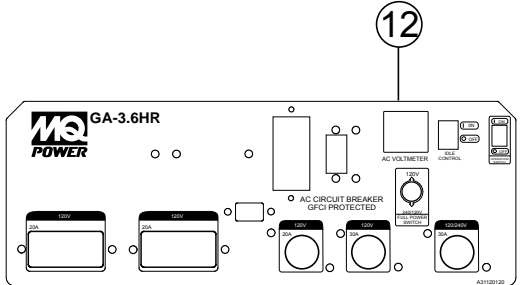
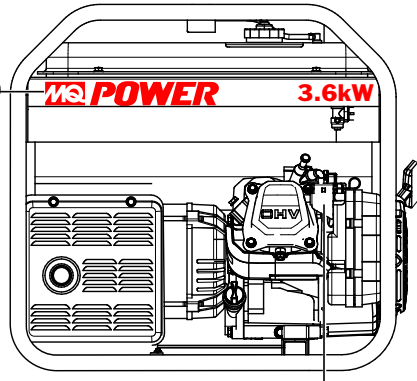
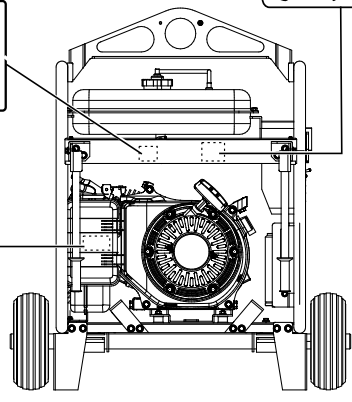

GA3.6HR — NAMEPLATE AND DECALS ASSY.

<u>NO.</u>	<u>PART NO.</u>	<u>PART NAME</u>	<u>QTY.</u>	<u>REMARKS</u>
1	A9521200104	DECAL: OPERATING INSTRUCTIONS	1	A92120010
2	A9504000014	DECAL: WARNING DANGEROUS GAS	1.....	A90400001
3		DECAL: NAMEPLATE.....	1.....	CONTACT MQ PARTS DEPT.
4	M9504200004	DECAL: WARNING START FIRES	1.....	M90420000
5	D9531100104	DECAL: DANGER ELECTROCUTION	1.....	A93110010
6	0800628504	DECAL: GROUND	1.....	S1123
7	A9511100103	DECAL: WARNING	1.....	A91110010
8	1980680004	DECAL: FUEL COCK	1.....	S3704
9	A3551000104	DECAL: HANDLE OPERATION	1.....	A35100010
10	87533ZC0630	DECAL: AIR CLEANER	1.....	REPLACES P/N 0600500045
11	A3561000503	DECAL: MQ POWER GA3.6H	1	
12	A3511201202	DECAL: CONTROL PANEL	1.....	A31120120
13	87528898620	DECAL: CHOKE	1.....	REPLACES P/N 0600500047

GA3.6HR — GENERATOR ASSY.

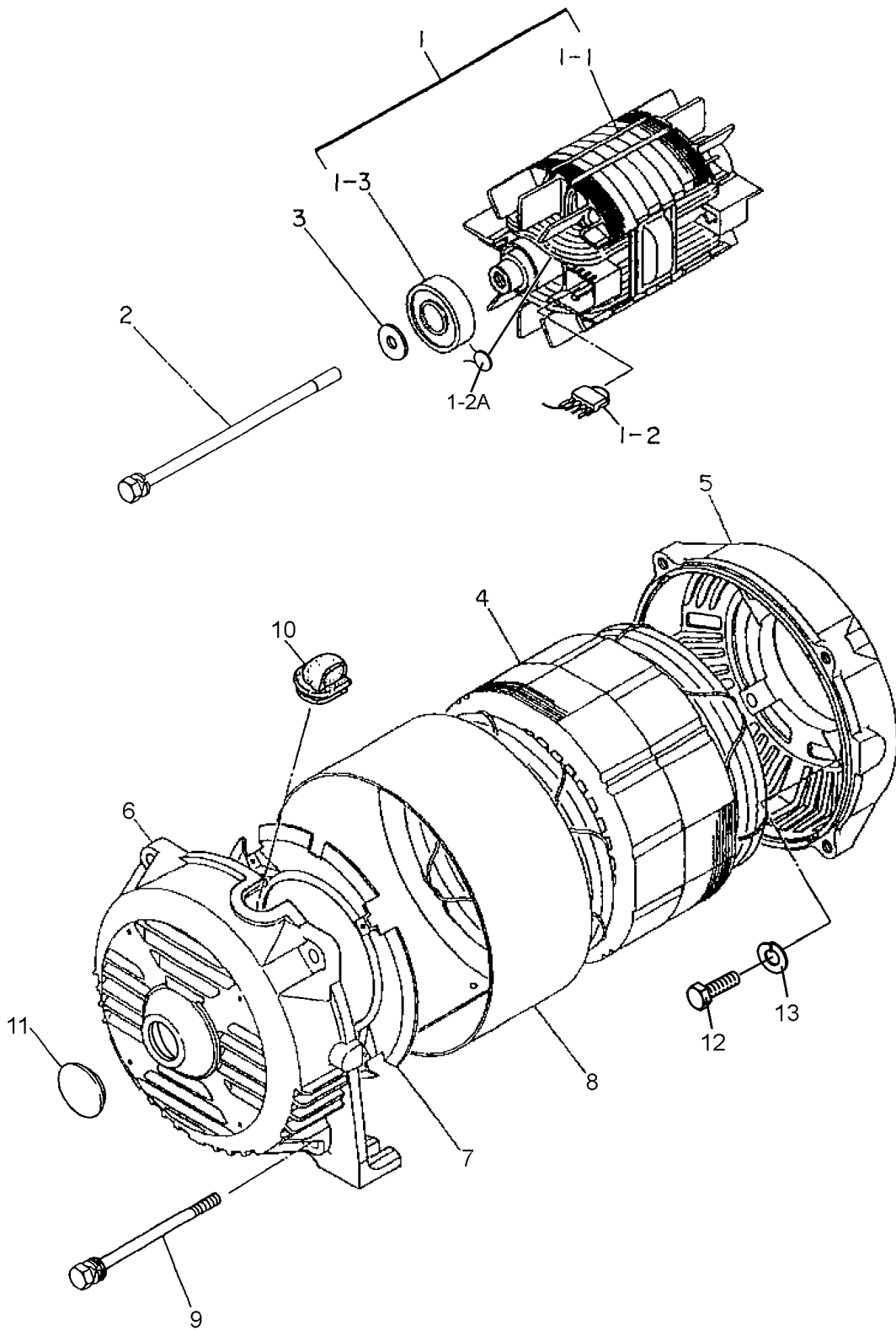

GA3.6HR — GENERATOR ASSY.

<u>NO.</u>	<u>PART NO.</u>	<u>PART NAME</u>	<u>QTY.</u>	<u>REMARKS</u>
1	7911002003	ROTOR ASSY.	1	
1-1		FIELD ASSY.	1	
1-2	0601823213	RECTIFIER	2	
1-2A	0601822638	SURGE ABSORBER	2	
1-3	0071706304	BEARING	1	
2	7911017004	SET BOLT, ROTOR	1	
3	0801086104	SET WASHER, BEARING	1	
4	A3135000003	ARMATURE ASSY.	1	
5	7901315502	END BRACKET	1	
6	7871315022D	END BRACKET	1	REPLACES P/N 7871315022
7	7875021523	GUIDE PANEL, AIR	1	
8	7661331003	COVER	1	
9	7911316004	SET BOLT, STATOR	4	
10	7871329514	GROMMET	1	
11	0601851760	CAP	1	
12	0013608020	HEX. HEAD BOLT	4	
13	0040008000	WASHER, LOCK	4	

GA3.6HR — CONTROL BOX ASSY.

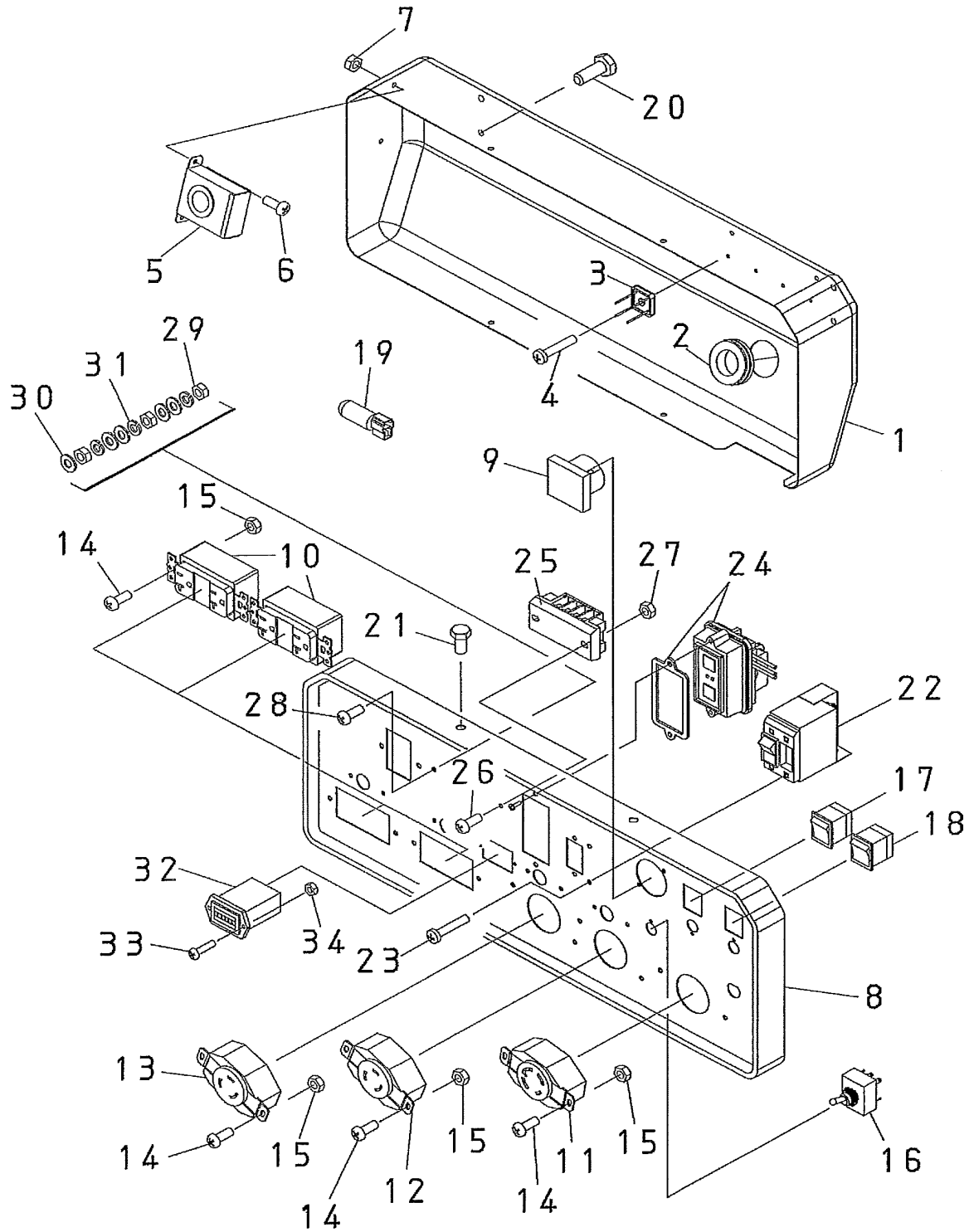

GA3.6HR — CONTROL BOX ASSY.

<u>NO.</u>	<u>PART NO.</u>	<u>PART NAME</u>	<u>QTY.</u>	<u>REMARKS</u>
1	A3214000403	CONTROL BOX	1	
2	0601850102	GROMMET	1	
3	0601823204	RECTIFIER	2	
4	0027103012	MACHINE SCREW	2	
5	0601823853	SLOW DOWN UNIT	1	
6	0027104010	MACHINE SCREW	2	
7	OEMAA8	HEX. NUT	2	REPLACES P/N 0207004000
8	A3224000703	CONTROL PANEL	1	
9	0601806819	AC VOLTMETER, 0~120 240V	1	
10	0601814065	RECEPTACLE	2	
11	0601811092	RECEPTACLE	1	REPLACES P/N 0601812592
12	0601811031	RECEPTACLE	1	REPLACES P/N 0601811035
13	0601814010	RECEPTACLE	1	
14	0021004010	MACHINE SCREW	10	
15	OEMAA8	HEX. NUT	10	REPLACES P/N 0207004000
16	0601830737	FULL POWER SWITCH	1	
17	0601831620	IDLE CONTROL SWITCH	1	
18	0601831620	OPERATION SWITCH	1	
19	A3262800004	CONDENSER ASSY.	1	
20	0011106015	HEX. HEAD BOLT	4	REPLACES P/N 0017106015
21	0017105010	HEX. HEAD BOLT	4	
22	0601872300	CIRCUIT BREAKER, 120V 15A 2P	1	
23	0021003005	MACHINE SCREW	4	
24	0601829301	EARTH LEAKAGE RELAY, 120V	1	
25	Y0601815779	TERMINAL BOARD	1	
26	0021004020	MACHINE SCREW	2	
27	OEMAA8	HEX. NUT	2	REPLACES P/N 0207004000
28	0021004025	MACHINE SCREW	1	
29	OEMAA8	HEX. NUT	3	REPLACES P/N 0030004000
30	58042	WASHER, FLAT	5	REPLACES P/N 0041204000
31	0040004000	WASHER, LOCK	3	
32	Y0601800699	HOUR METER	1	
33	Y0021003012	HEX. HEAD BOLT	2	
34	0207003000	HEX. NUT	2	

GA3.6HR — PIPE FRAME ASSY.

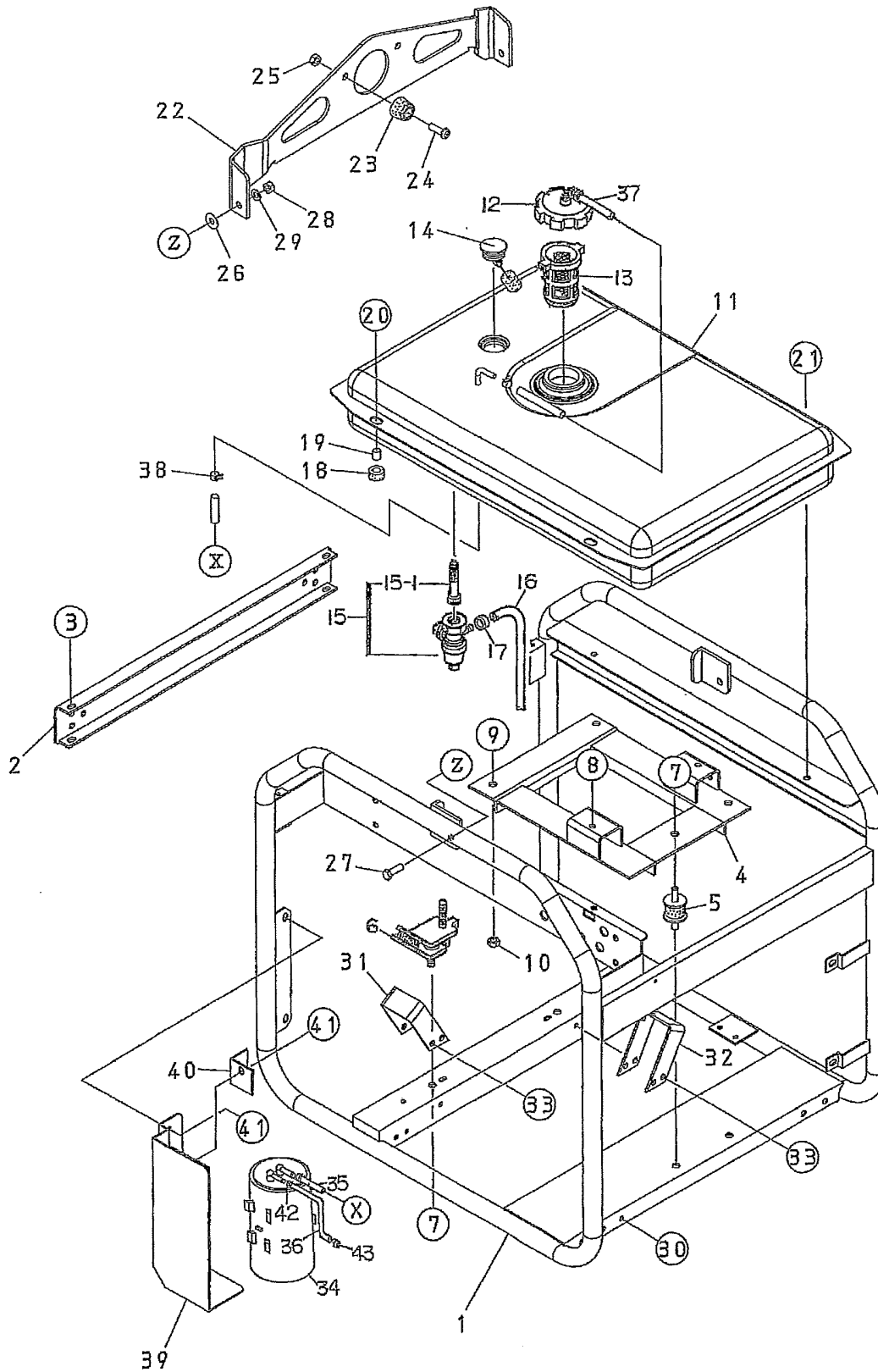

GA3.6HR — PIPE FRAME ASSY.

<u>NO.</u>	<u>PART NO.</u>	<u>PART NAME</u>	<u>QTY.</u>	<u>REMARKS</u>
1	A3417000502	PIPE FRAME	1	
2	A3417100204	BRACKET	1	
3	011106015	HEX. HEAD BOLT	4	REPLACES P/N 0017106015
4	7915443003	BASE	1	
5	7895419004	RUBBER SUSPENSION	2	
6	1665419004	RUBBER SUSPENSION	2	REPLACES P/N 1725419214
7	020108060	HEX. NUT	8	REPLACES P/N 0207008000
8	0017108030	HEX. HEAD BOLT	2	
9	0017108040	HEX. HEAD BOLT	2	
10	Y0207008000	HEX. NUT	2	
11	A3361000004	FUEL TANK	1	
12	0430430120	CAP, FUEL TANK	1	REPLACES P/N 0605505068
13	0641360030	FUEL FILTER	1	REPLACES P/N 0605505162
14	0602125034	FUEL GAUGE	1	
15	16950ZB4015	FUEL STRAINER	1	REPLACES P/N 0605510068
15-1	16952KJ9752	SCREEN SET	1	REPLACES P/N 16952ZB4005
16	Y0605513215	HOSE	1	
17	950024080008	HOSE BAND	2	
18	7855525514	RUBBER CUSHION	2	
19	7855525604	COLLAR	2	
20	011208030	HEX. HEAD BOLT	2	REPLACES P/N 0017108030
21	011008020	HEX. HEAD BOLT	2	REPLACES P/N 0017108020
22	A9117200103	HANGER	1	
23	0601850097	STOPPER	1	
24	011208025	MACHINE SCREW	1	REPLACES P/N 0021008025
25	020108060	HEX. NUT	1	REPLACES P/N 0207008000
26	0601851116	PLASTIC WASHER	2	
27	011208025	HEX. HEAD BOLT	2	REPLACES P/N 0011308025
28	0207608000	HEX. NUT	2	
29	0042108000	WASHER, FLAT	2	
30	0019206015	HEX. HEAD BOLT	1	
31	7915455103	COVER	1	
32	7855455003	COVER	1	
33	011106015	HEX. HEAD BOLT	6	REPLACES P/N 0017106015
34	0605507002	CANISTER	1	
35	0605513202	HOSE	1	
36	Y0605513210	HOSE	1	
37	0605513189	HOSE	1	
38	0605515223	HOSE BAND	2	
39	A3261600103	BRACKET	1	
40	A3261600204	STOPPER	1	
41	011106015	HEX. HEAD BOLT	3	REPLACES P/N 0016906015
42	0605515170	HOSE BAND	1	
43	Y0605515229	HOSE BAND	1	

GA3.6HR — MUFFLER ASSY.

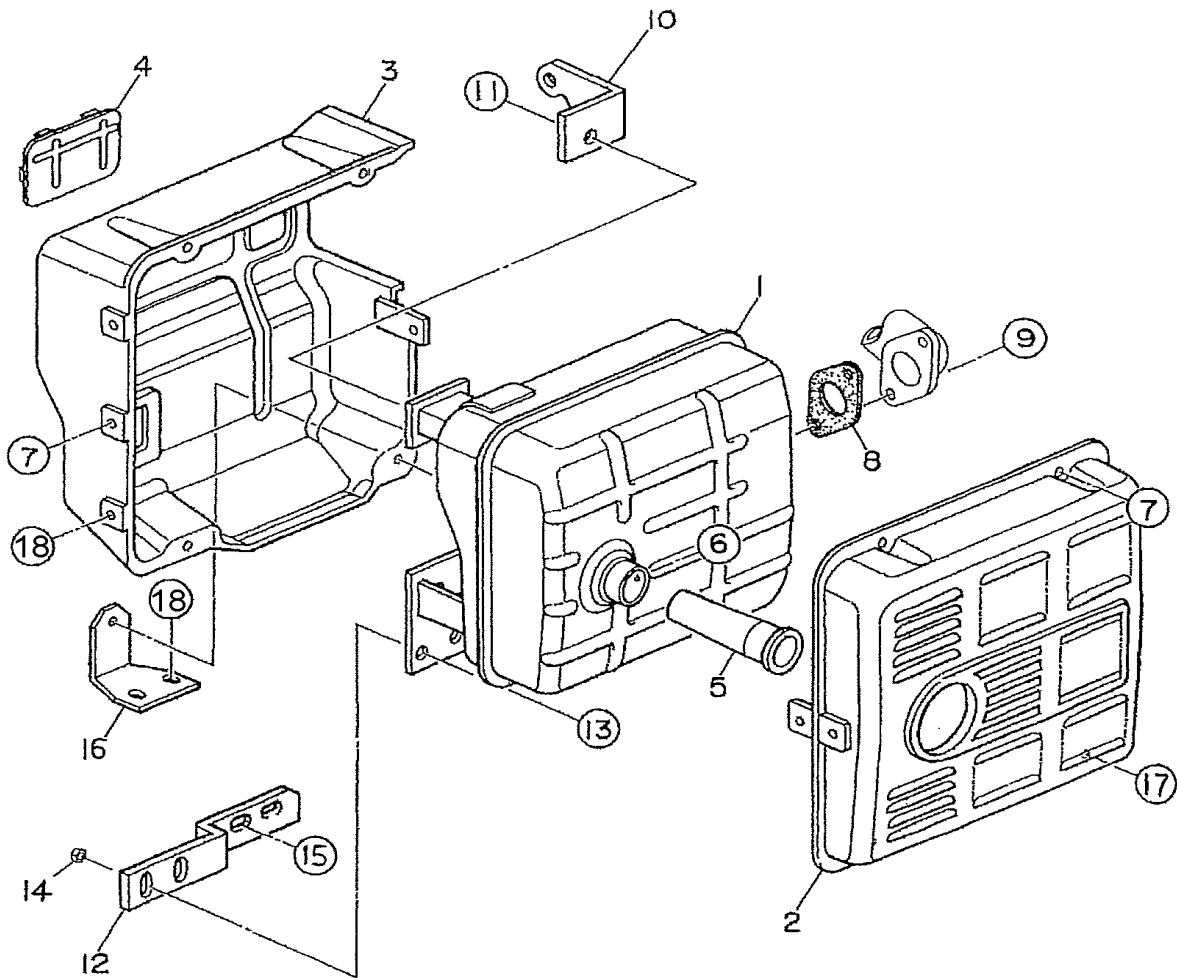

GA3.6HR — MUFFLER ASSY.

<u>NO.</u>	<u>PART NO.</u>	<u>PART NAME</u>	<u>QTY.</u>	<u>REMARKS</u>
1	7912310003	MUFFLER	1	
2	18320ZB4000	PROTECTOR	1	
3	18325ZB4000	PROTECTOR	1	
4	18329ZB4000	SEAL	2	
5	18355ZB4630	ARRESTOR, SPARK	1	
6	90002ZE2U91	TAPPING SCREW	1	
7	0105050616	HEX. HEAD BOLT	5.....	REPLACES P/N 0017106012
8	18333ZB4801	GASKET	1	
9	957010802000	HEX. HEAD BOLT	2	
10	7915461004	BRACKET	1	
11	0017108020	HEX. HEAD BOLT	1.....	REPLACES P/N 0017108020
12	7915460004	BRACKET	1	
13	0017108025	HEX. HEAD BOLT	2.....	REPLACES P/N 0017108025
14	020108060	HEX. NUT	2.....	REPLACES P/N 0207008000
15	011008020	HEX. HEAD BOLT	2.....	REPLACES P/N 0017108020
16	7915469004	BRACKET	1	
17	011206020	HEX. HEAD BOLT	1.....	REPLACES P/N 0017106020
18	0105050616	HEX. HEAD BOLT	4.....	REPLACES P/N 0017106012

GA3.6HR — WHEEL KIT ASSY.

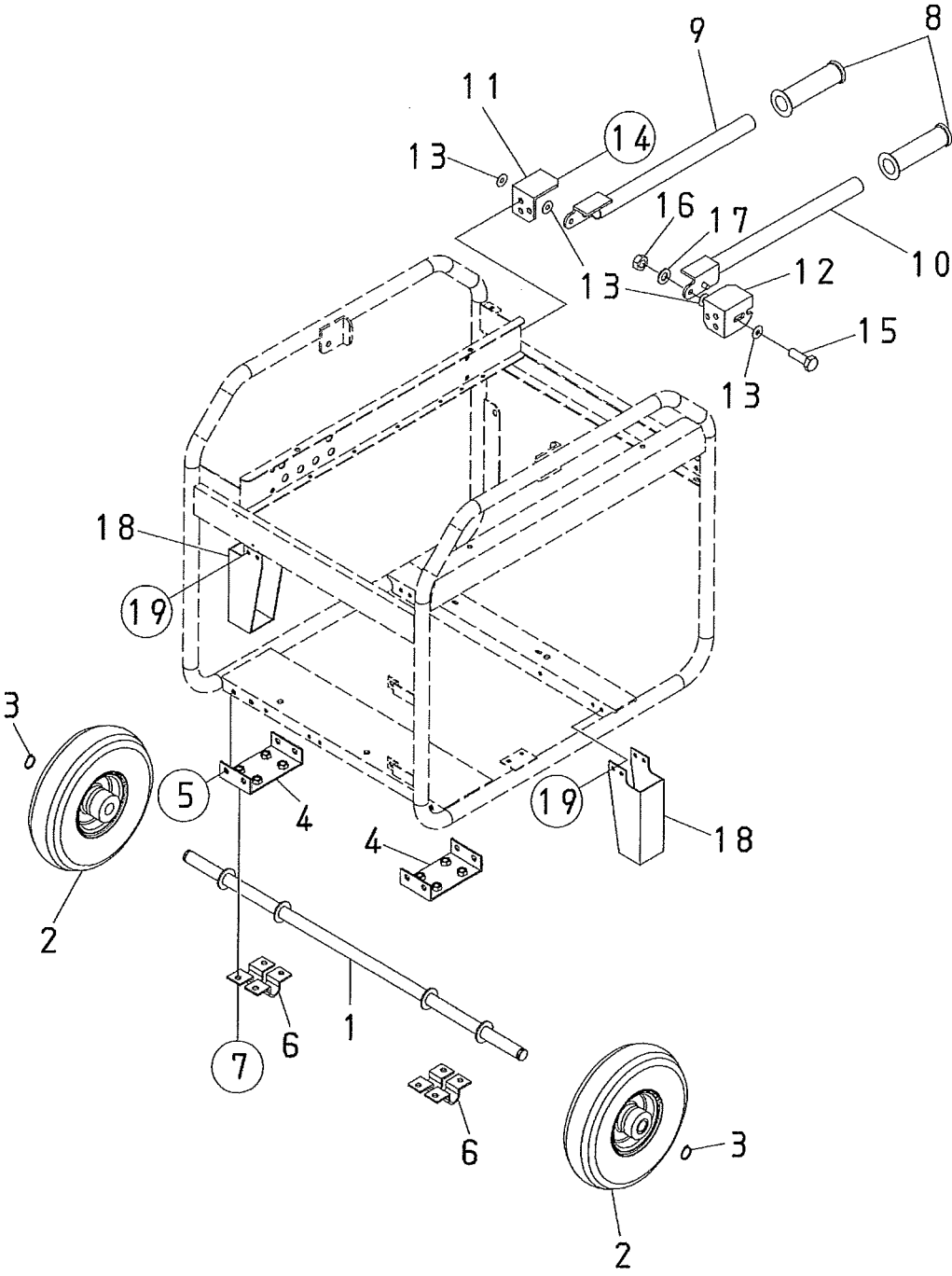

GA3.6HR — WHEEL KIT ASSY.

<u>NO.</u>	<u>PART NO.</u>	<u>PART NAME</u>	<u>QTY.</u>	<u>REMARKS</u>
1	A3417400303	AXLE	1	
2	Y0605802053	TIRE ASSY.	2	
3	Y0080000020	SNAP RING	2	
4	A3417400404	BRACKET	2	
5	011008020	HEX. HEAD BOLT	8.....	REPLACES P/N 0016908020
6	L0120236304	BRACKET, BRAKE SHAFT	4	
7	011008020	HEX. HEAD BOLT	8.....	REPLACES P/N 0016908020
8	W0805003103	GRIP	2	
9	A3417400704	HANDLE	1	
10	A3417400804	HANDLE	1	
11	A3417401304	BRACKET, HANDLE	1	
12	A3417401404	BRACKET, HANDLE	1	
13	0601851116	WASHER	4	
14	0012308020	HEX. HEAD BOLT	6	
15	0010108025	HEX. HEAD BOLT	2	
16	0207608000	U-NUT	2	
17	0401450080	WASHER, FLAT	2.....	REPLACES P/N 0041208000
18	A3417400904	STAND	2	
19	011106015	HEX. HEAD BOLT	8.....	REPLACES P/N 0016906015

HONDA GX240RT2EDN2 — AIR CLEANER ASSY.

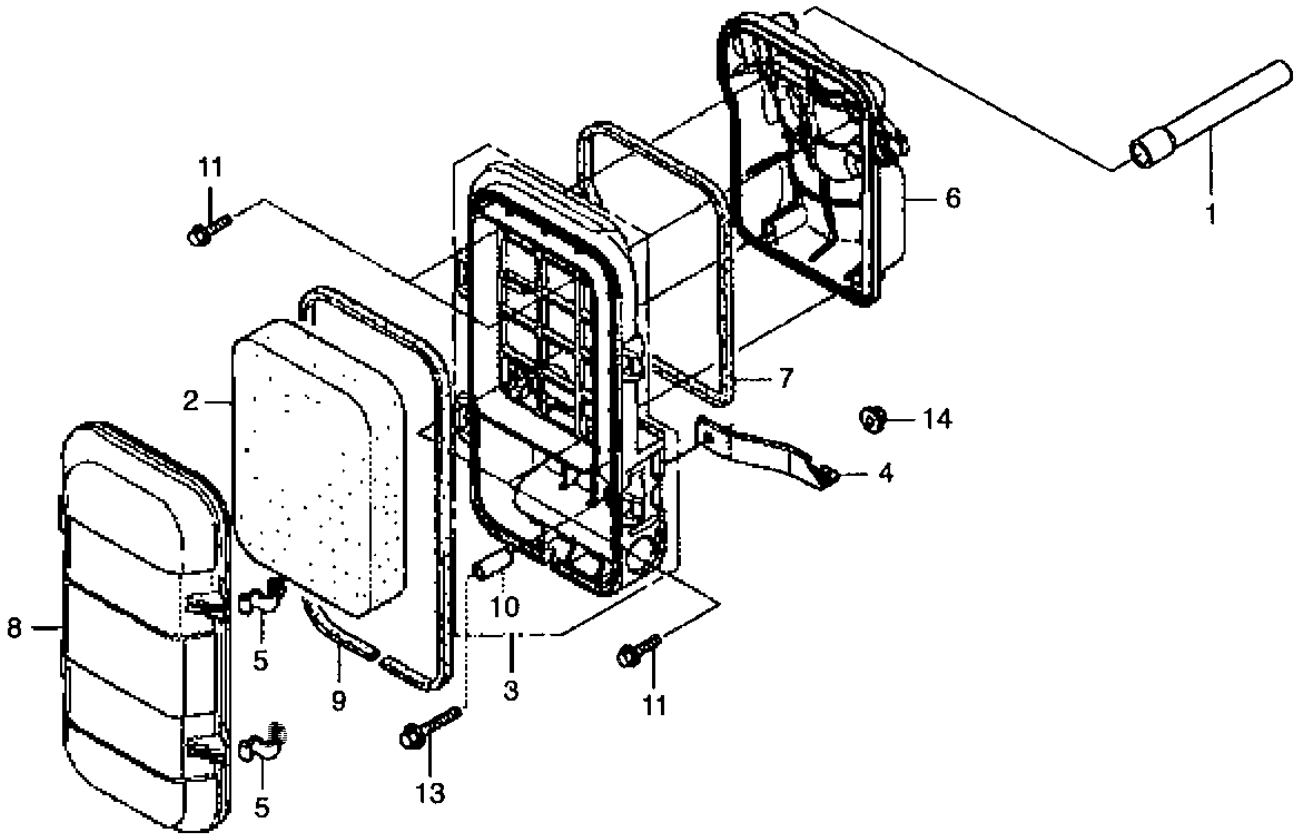

HONDA GX240RT2EDN2 — AIR CLEANER ASSY.

<u>NO.</u>	<u>PART NO.</u>	<u>PART NAME</u>	<u>QTY.</u>	<u>REMARKS</u>
1	15721Z23H60	TUBE, BREATHER	1	
2	17211899000	ELEMENT, AIR CLEANER	1	
3	17220Z23S30	CASE COMP., AIR CLEANER	1	
4	17222Z23H60	STAY, AIR CLEANER	1	
5	17223Z23000	SPRING, AIR CLEANER CASE LID	2	
6	17223Z23S30	BASE COMP., AIR CLEANER	1	
7	17229Z23H60	SEAL, AIR CLEANER CASE	1	
8	17231Z23H60	COVER, AIR CLEANER	1	
9	17233Z23H60	SEAL, AIR CLEANER COVER	1	
10	17238ZE7710	COLLAR, AIR CLEANER	1	
11	90005ZM3000	BOLT, FLANGE 5X18	4	
13	90854ZB3000	RUBBER, FUEL 9X15X20	1	
14	9405006000	NUT, FLANGE 6MM	1	
15	957010603208	BOLT, FLANGE 6X32	1	

HONDA GX240RT2EDN2 — CAMSHAFT ASSY.

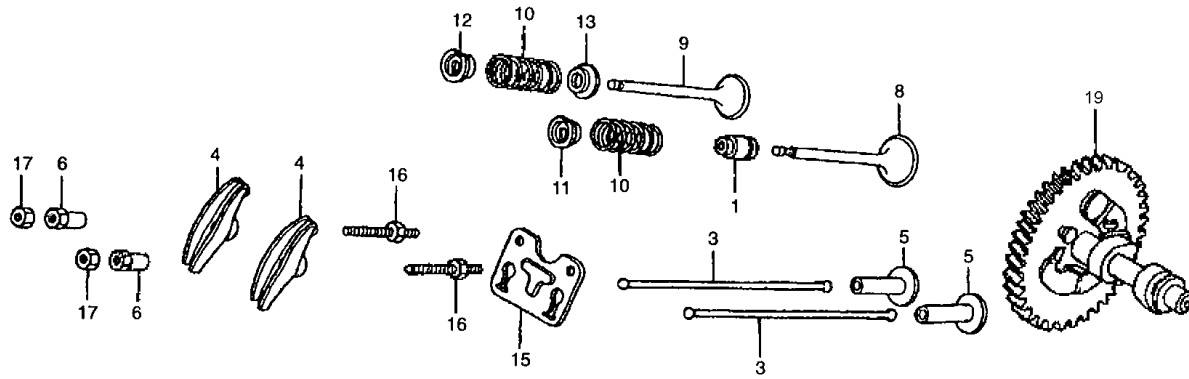

HONDA GX240RT2EDN2 — CAMSHAFT ASSY.

<u>NO.</u>	<u>PART NO.</u>	<u>PART NAME</u>	<u>QTY.</u>	<u>REMARKS</u>
1	12209ZE8003	SEAL, VALVE STEM	1	
3	14410Z1D000	ROD, PUSH	2	
4	14431ZE2010	ARM, VALVE ROCKER	2	
5	14441ZE2000	LIFTER, VALVE	2	
6	14451ZE1013	PIVOT, ROCKER ARM	2	
8	14711Z5K000	VALVE, IN.	1	
9	14721Z5K000	VALVE, EX.	1	
10	14751Z1C000	SPRING, VALVE	2	
11	14771Z8S000	RETAINER, IN. VALVE SPRING	1	
12	14771Z8S000	RETAINER, EX. VALVE SPRING	1	
13	14775ZE2010	SEAT, VALVE SPRING	1	
15	14791Z1D000	GUIDE, PUSH ROD	1	
16	90012ZE0010	BOLT, PIVOT 8MM	2	
17	90206ZE1000	NUT, PIVOT ADJUSTING	2	
19	14100Z5K910	CAMSHAFT COMP. (STD)	1	

HONDA GX240RT2EDN2 — CARBURETOR ASSY.

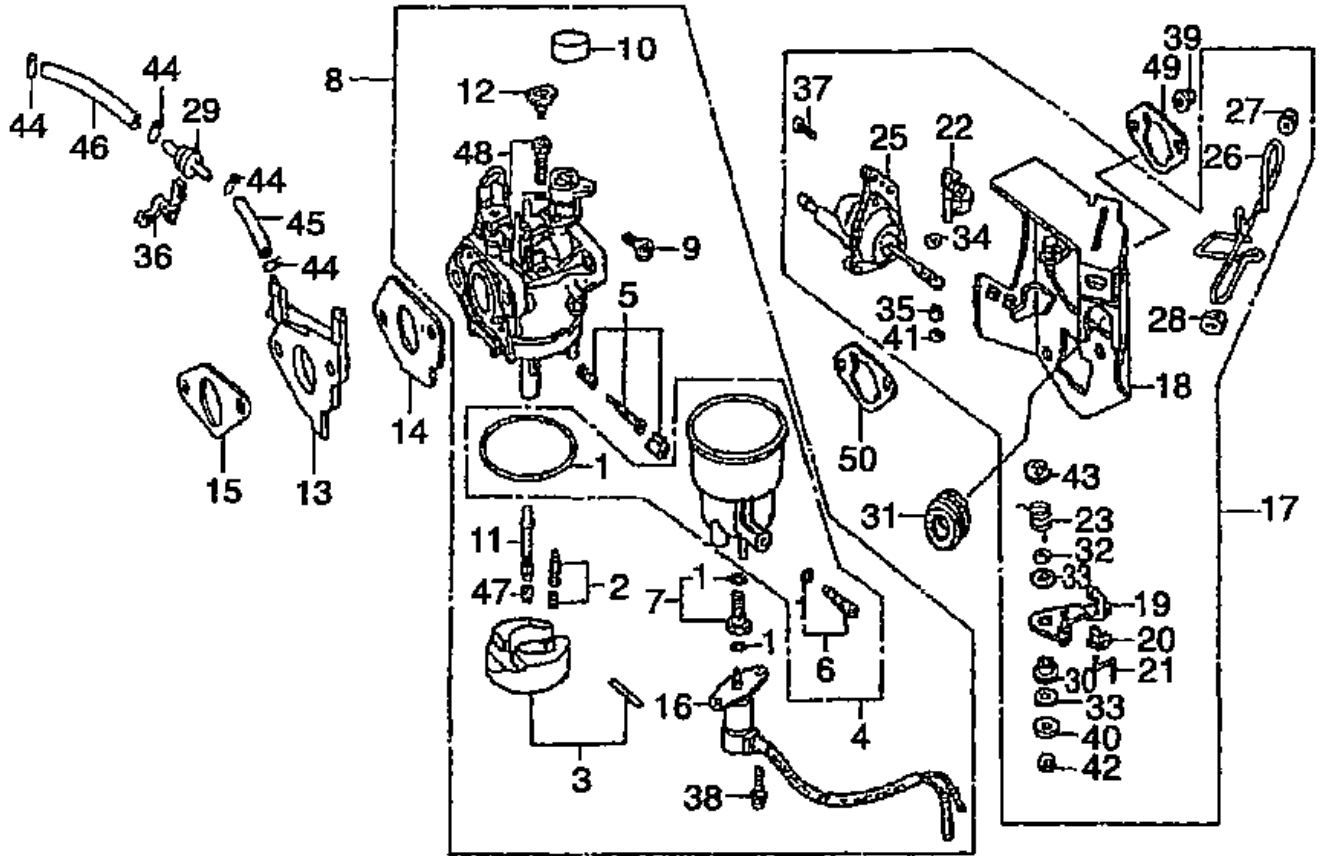

HONDA GX240RT2EDN2 — CARBURETOR ASSY.

<u>NO.</u>	<u>PART NO.</u>	<u>PART NAME</u>	<u>QTY.</u>	<u>REMARKS</u>
1#@	16010ZE3701	GASKET SET	1	
2@	16011ZA0931	VALVE SET, FLOAT	1	
3@	16013Z1C003	FLOAT SET	1	
4@	16015ZA0931	CHAMBER SET, FLOAT	1	INCLUDES ITEMS W/#
5@	16016ZH7W01	SCREW SET, PILOT	1	
6#@	16024124760	SCREW SET, DRAIN	1	
7@	16028ZA0931	SCREW SET	1	
8	16100Z8S932	CARBURETOR ASSY. (BE72R A).....	1	INCLUDES ITEMS W/@
9@	16124ZE0005	SCREW, THROTTLE STOP	1	
10@	16148141881	CAP, CHOKE DUST	1	
11@	16166Z8S931	NOZZLE, MAIN	1	
12@	16172ZE3W10	COLLAR, SETTING	1	
13	16211ZE2701	INSULATOR, CARBURETOR	1	
14	16221Z5K000	PACKING, CARBURETOR	1	
15	16212Z5K000	PACKING, INSULATOR	1	
16@	16230ZE3702	VALVE ASSY., SOLENOID	1	
17	16260ZE3D22	STAY ASSY., MANUAL CHOKE.....	1	INCLUDES ITEMS W/&
18&	16261ZE2702	STAY COMP., SOLENOID	1	
19&	16262ZE2711	LEVER, CHOKE	1	
20&	16263ZA0000	JOINT, ROD	1	
21&	16264ZE2701	ROD, CHOKE	1	
22&	16265ZE2721	STOPPER, CHOKE ROD	1	
23&	16268ZE2721	SPRING, MANUAL CHOKE	1	
25&	16400ZE2704	DIAPHRAGM ASSY.	1	
26&	16611ZE3D21	ROD, CHOKE CONTROL	1	
27&	16613893000	GROMMET, CHOKE ROD	1	
28&	16615893000	GUIDE, CHOKE ROD	1	
29	36135ZF6D41	VALVE, DASHPOT CHECK	1	
30&	53149964003	BUSH, ARM PIVOT	1	
31	88911MJ3000	GROMMET, FENDER	1	
32&	90431ZE2700	WASHER, CHOKE LEVER	1	
33&	90432ZE2700	SEAL, CHOKE LEVER	2	
34&	90433ZE2700	WASHER, THRUST, 2.7X8	1	
35&	90434ZE2700	COLLAR, LEVER	1	
36	90650SD9003	CLIP, WIRE HARNESS	1	
37&	93500050120A	SCREW, PAN 5X12	2	
38@	938920501208	SCREW, WASHER 5X12	2	REPLACES P/N 938920501218
39	9405006000	NUT, FLANGE 6MM	2	
40&	9410305000	WASHER, FLAT 5MM	1	
41&	9454002010	E-RING 2MM	1	
42&	9454004010	E-RING 4MM	1	
43&	9454007010	E-RING 7MM	1	
44	9500202070	CLIP, TUBE (B7)	4	
45	950053506510	TUBE, 3.5X65	1	
46	950053513010	TUBE, 3.5X130	1	
47@	99101ZH80780	JET, MAIN #78	1	
47@	99101ZH80800	JET, MAIN #80	1	
47@	99101ZH80820	JET, MAIN #82	1	
48@	99204ZE00380	JET SET, PILOT #38	1	
49	16220ZA0702	SPACER, CARBURETOR	1	
50	17228Z5T000	PACKING, AIR CLEANER	1	

HONDA GX240RT2EDN2 — CONTROL ASSY.

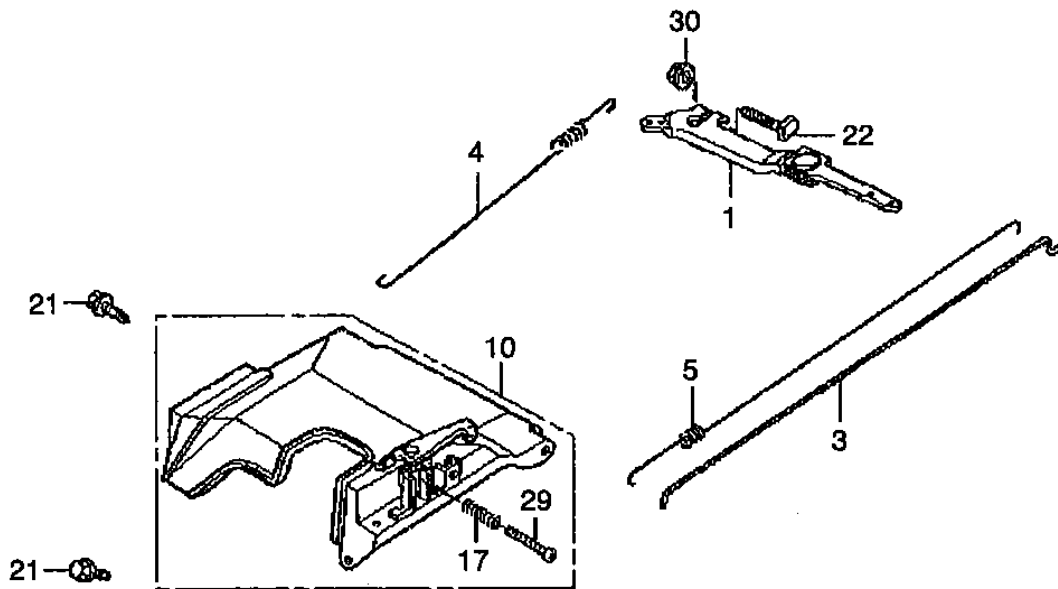

HONDA GX240RT2EDN2 — CONTROL ASSY.

<u>NO.</u>	<u>PART NO.</u>	<u>PART NAME</u>	<u>QTY.</u>	<u>REMARKS</u>
1	16550ZE2700	ARM COMP, GOVERNOR	1	
3	16555ZE2000	ROD, GOVERNOR	1	
4	16561ZK6D70	SPRING, GOVERNOR	1	
5	16562ZE2700	SPRING, THROTTLE RETURN	1	
10	16500Z5K408	CONTROL ASSY.	1	INCLUDES ITEMS W/#
17#	16584883300	SPRING, CONTROL ADJUSTING	1	
21	90013883000	BOLT, FLANGE 6X12	2	
22	90015Z5T000	BOLT, GOVERNOR ARM	1	
29#	93500050350A	SCREW, PAN 5X35	1	
30	9405006000	NUT, FLANGE 6MM	1	

HONDA GX240RT2EDN2 — CRANKCASE COVER ASSY.

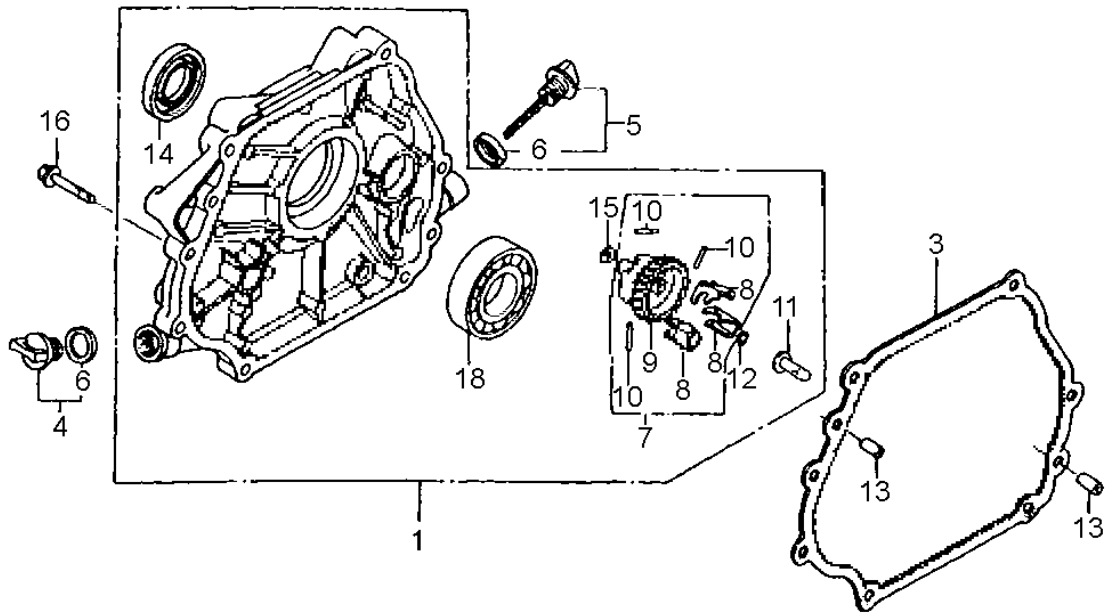

HONDA GX240RT2EDN2 — CRANKCASE COVER ASSY.

NO.	PART NO.	PART NAME	QTY.	REMARKS
1	11300Z9GS40	COVER ASSY., CRANKCASE	1.....	INCLUDES ITEMS W/%
3	11381Z5K000	PACKING, CASE COVER	1	
4	15600Z0T820	CAP ASSY., OIL FILTER	1.....	INCLUDES ITEMS W/#
5	15600Z1C000	CAP ASSY., OIL FILTER	1.....	INCLUDES ITEMS W/\$
6#\$	15625Z0T800	PACKING, OIL FILTER CAP	2	
7%	16510ZE3000	GOVERNOR ASSY.	1.....	INCLUDES ITEMS W/@
8%@	16511ZE8000	WEIGHT, GOVERNOR	3	
9%@	16512ZE3000	HOLDER, GOVERNOR WEIGHT	1	
10%@	16513ZE2000	PIN, GOVERNOR WEIGHT	3	
11%	16531Z0A000	SLIDER, GOVERNOR	1	
12%	90602ZE1000	CLIP, GOVERNOR HOLDER	1	
13	90701HC4000	DOWEL PIN, 8X12	2	
14%	91201Z10003	OIL SEAL, 30X46X8	1	
15%	58176	WASHER, FLAT 6MM	1.....	REPLACES P/N 9410106800
16	957010803500	BOLT, FLANGE 8X35	7	
18%	961006206000	BEARING, RADIAL BALL 6206	1	

HONDA GX240RT2EDN2 — CRANKSHAFT ASSY.

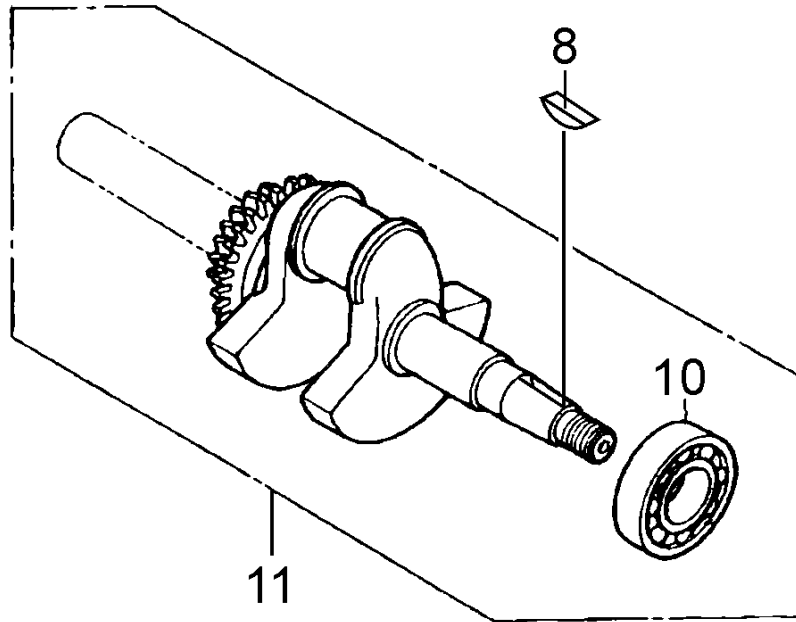

HONDA GX240RT2EDN2 — CRANKSHAFT ASSY.

<u>NO.</u>	<u>PART NO.</u>	<u>PART NAME</u>	<u>QTY.</u>	<u>REMARKS</u>
8	90741ZE2000	KEY, SPECIAL WOODRUFF 25X18	1	
10%	91001ZH9003	BEARING, RADIAL BALL (6206 SH)	1	
11	13310ZBAS40	CRANKSHAFT COMP,	1.....	INCLUDES ITEMS W/%

HONDA GX240RT2EDN2 — CYLINDER BARREL ASSY.

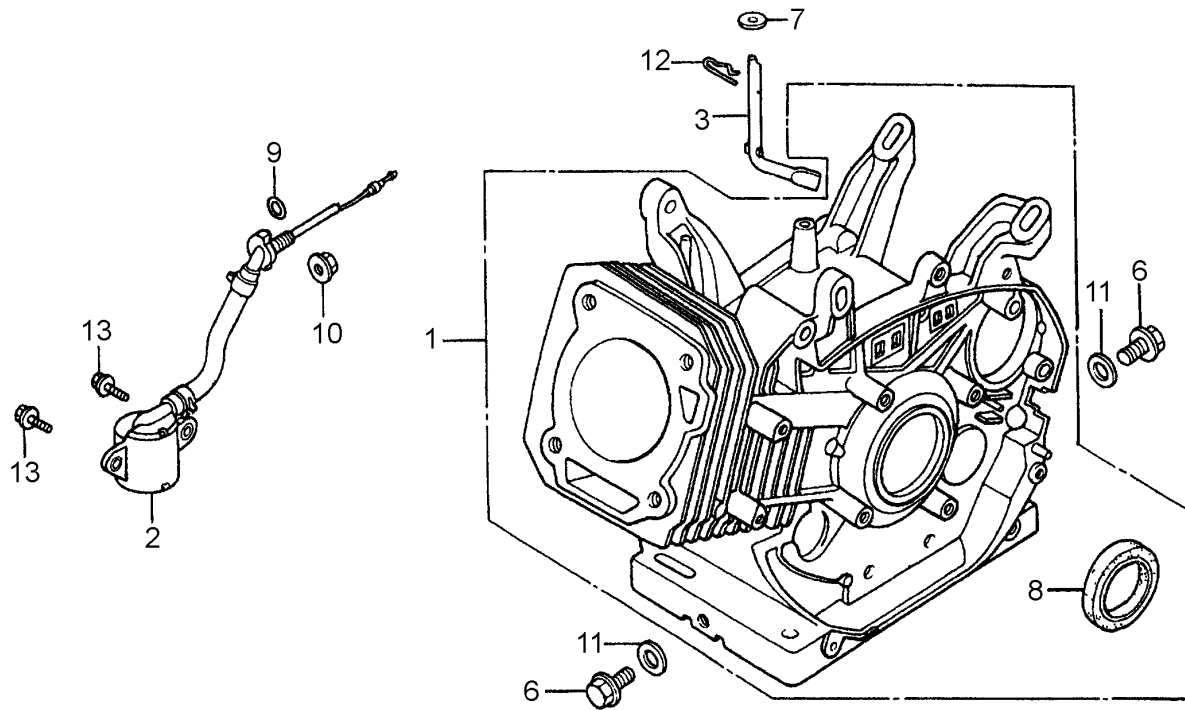

HONDA GX240RT2EDN2 — CYLINDER BARREL ASSY.

<u>NO.</u>	<u>PART NO.</u>	<u>PART NAME</u>	<u>QTY.</u>	<u>REMARKS</u>
1	12000Z5K406	BARREL ASSY., CYLINDER	1.....	INCLUDES ITEMS W/\$
2	35480ZF6003	SWITCH ASSY., OIL LEVEL	1	
3	16541ZE2010	SHAFT, GOVERNOR ARM	1	
6	90131896650	BOLT, DRAIN PLUG 12X15	2.....	REPLACES P/N 90131883000
7	90446KE1000	WASHER, 8.2X17X0.8	1	
8\$	91201Z1D003	OIL SEAL 30X46X8	1	
9	91353671003	O-RING, 14MM (NOK)	1.....	REPLACES P/N 91353671004
10	9405010000	NUT, FLANGE 10MM	1	
11	031112230	WASHER, DRAIN PLUG 12MM	2.....	REPLACES P/N 9410912000
12	9425110000	PIN, LOCK 10MM	1	
13	957010601200	BOLT, FLANGE 6X12	2	

HONDA GX240R2EDN2 — CYLINDER HEAD ASSY.

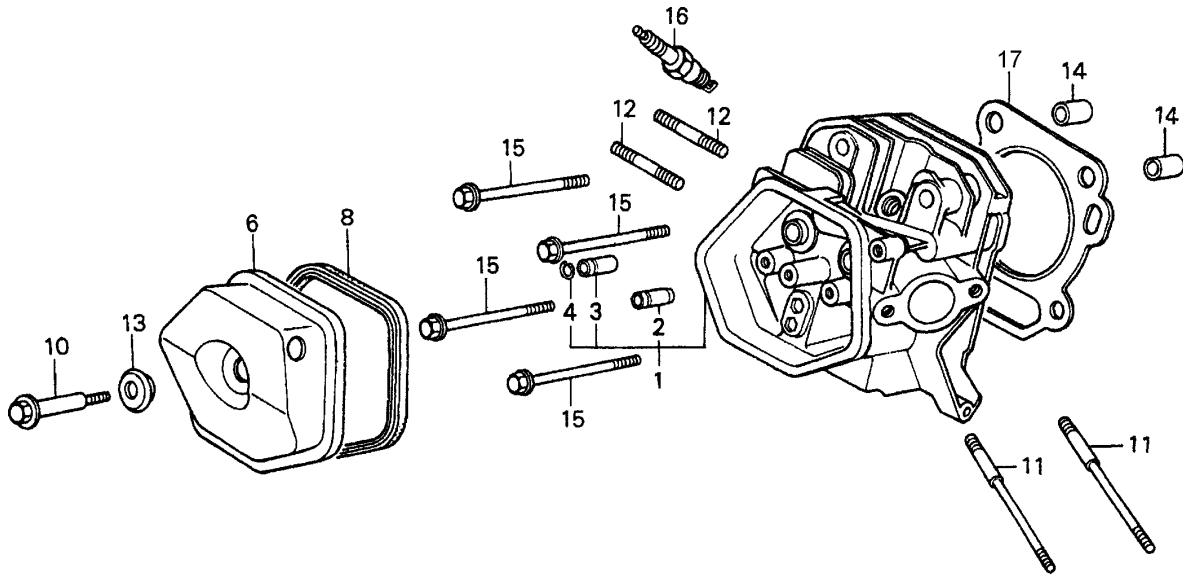

HONDA GX240REDN2 — CYLINDER HEAD ASSY.

<u>NO.</u>	<u>PART NO.</u>	<u>PART NAME</u>	<u>QTY.</u>	<u>REMARKS</u>
1	12210Z5K405	HEAD COMP., CYLINDER	1	
2	12204ZE2306	GUIDE, IN. VALVE (OVER SIZE)	1	
3	12205ZE2305	GUIDE, EX. VALVE (OVER SIZE)	1	
4	12216ZE2300	CLIP, VALVE GUIDE	1	
6	12310ZE2020	COVER, CYLINDER HEAD	1	
8	12391ZE2020	PACKING, HEAD COVER	1	
10	90014Z5T000	BOLT, HEAD COVER	1	
11	90042ZK2D60	BOLT, STUD, 8X106	2	
12	92900080320E	BOLT, STUD, 8X32	2	
13	90441ZE2010	WASHER CAMP., HEAD COVER	1	
14	9430112200	DOWEL PIN, 12X20	2	
15	9570H008000	BOLT, FLANGE, 10X80	4	
16	9807955876	PLUG, SPARK (BPR5ES NGK)	1	
16	9807955855	PLUG, SPARK (W16EPR~U DENSO)	1	
17	12251Z5K003	GASKET, CYLINDER HEAD	1	

HONDA GX240RT2EDN2 — FAN COVER ASSY.

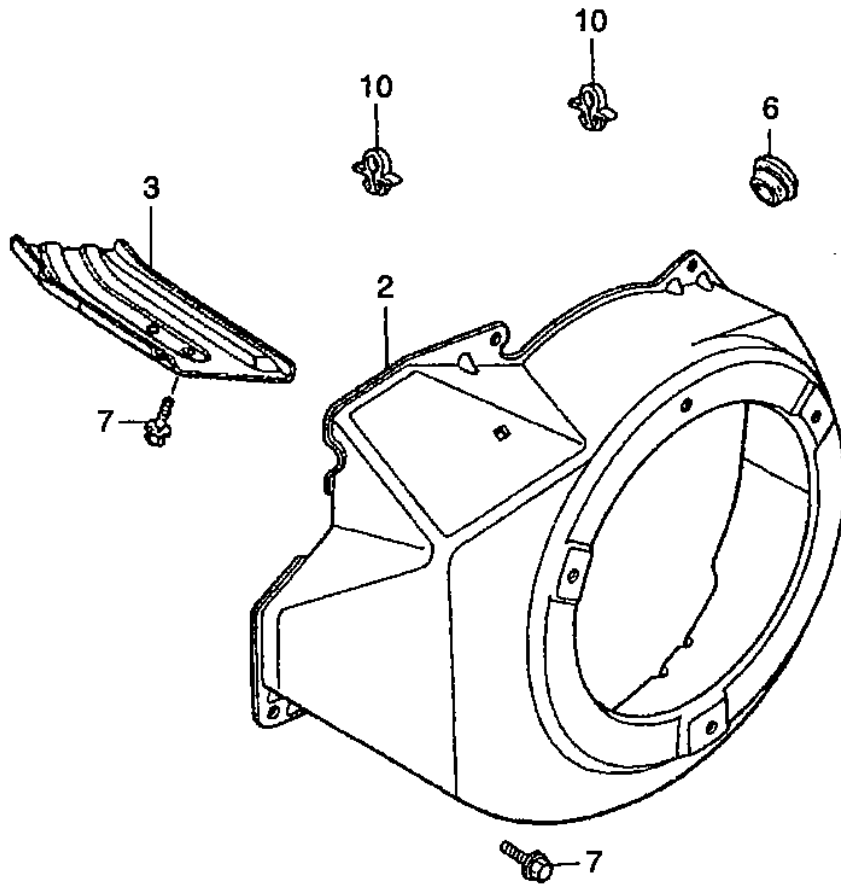

HONDA GX240RT2EDN2 — FAN COVER ASSY.

<u>NO.</u>	<u>PART NO.</u>	<u>PART NAME</u>	<u>QTY.</u>	<u>REMARKS</u>
2	19610Z5K800ZD	COVER COMP., FAN *NH1*	1	
3	19631Z5K000	SHROUD	1	
6	81329567020	GROMMET, DRAIN HOLE	1	
7	90013883000	BOLT, FLANGE 6X12 (CT200)	6	
10	90654SA4003	CLIP, WIRE HARNESS 6MM (WHITE)	2	

HONDA GX240RT2EDN2 — FLYWHEEL ASSY.

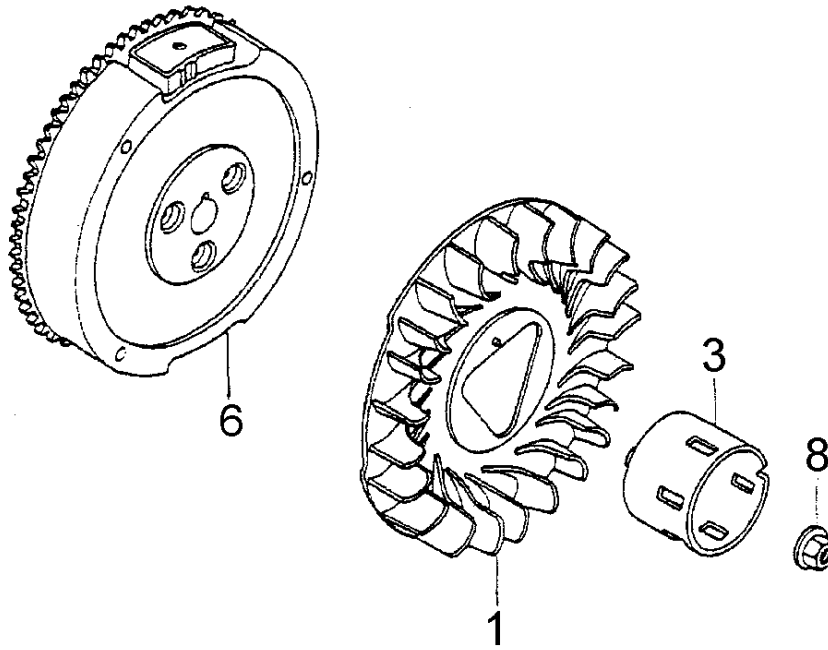

HONDA GX240RT2EDN2 — FLYWHEEL ASSY.

<u>NO.</u>	<u>PART NO.</u>	<u>PART NAME</u>	<u>QTY.</u>	<u>REMARKS</u>
1	19511ZE2000	FAN, COOLING	1	
3	28451ZE2W01	PULLEY, STARTER	1	
6	31110Z5K810	FLYWHEEL COMP. (LAMP)	1	
8	90201ZE3790	NUT, SPECIAL 16MM	1	

HONDA GX240RT2EDN2 — IGNITION COIL ASSY.

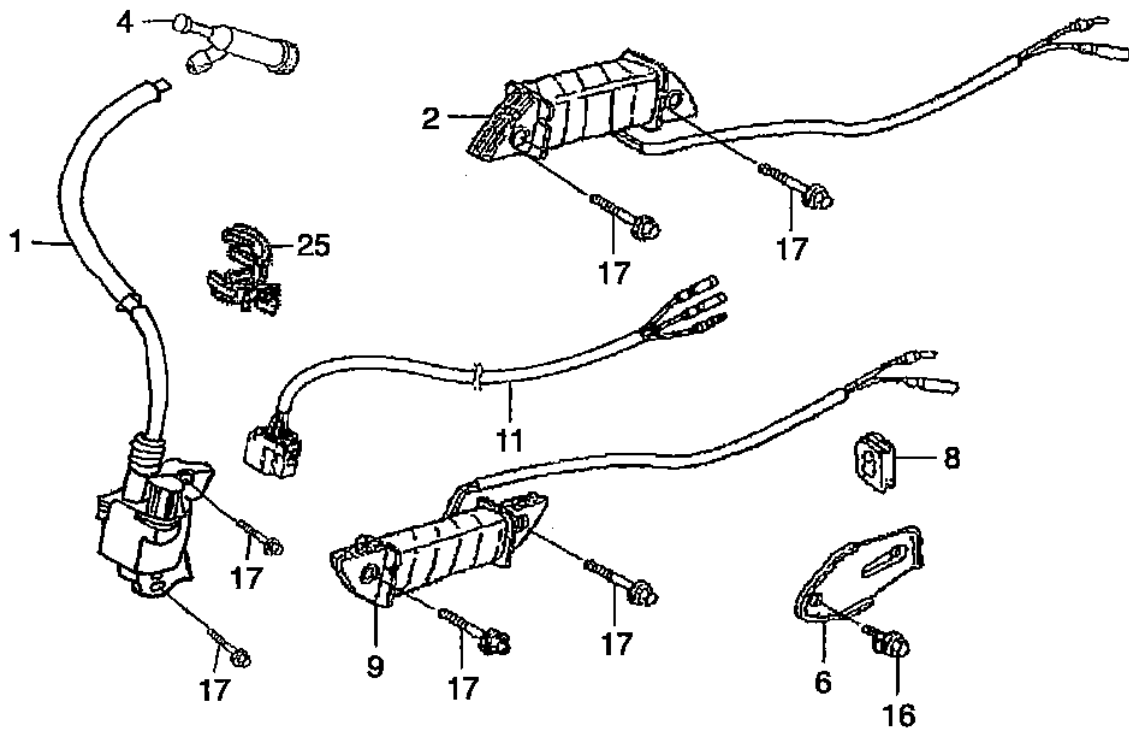

HONDA GX240RT2EDN2 — IGNITION COIL ASSY.

<u>NO.</u>	<u>PART NO.</u>	<u>PART NAME</u>	<u>QTY.</u>	<u>REMARKS</u>
1	30500Z5F003	COIL ASSY., IGNITION	1	
2	31510ZE1811	COIL ASSY., LAMP 12V 125W	1	
4	30700Z1C811	CAP ASSY., NOISE SUPPRESSOR	1	
6	31511ZE2000	CLAMPER, CORD	1	
8	31512ZE2000	GROMMET, CORD	1	
9	31510ZE3003	COIL ASSY., LAMP 12V 125W	1	
11	32110Z5K000	HARNESS ASSY., ENGINE WIRE	1	
16	90013883000	BOLT, FLANGE 6X12	1	
17	90015883000	BOLT, FLANGE 6X28	6	
25	90684ZA0601	CLIP, HARNESS	1	

HONDA GX240RT2EDN2 — PISTON ASSY.

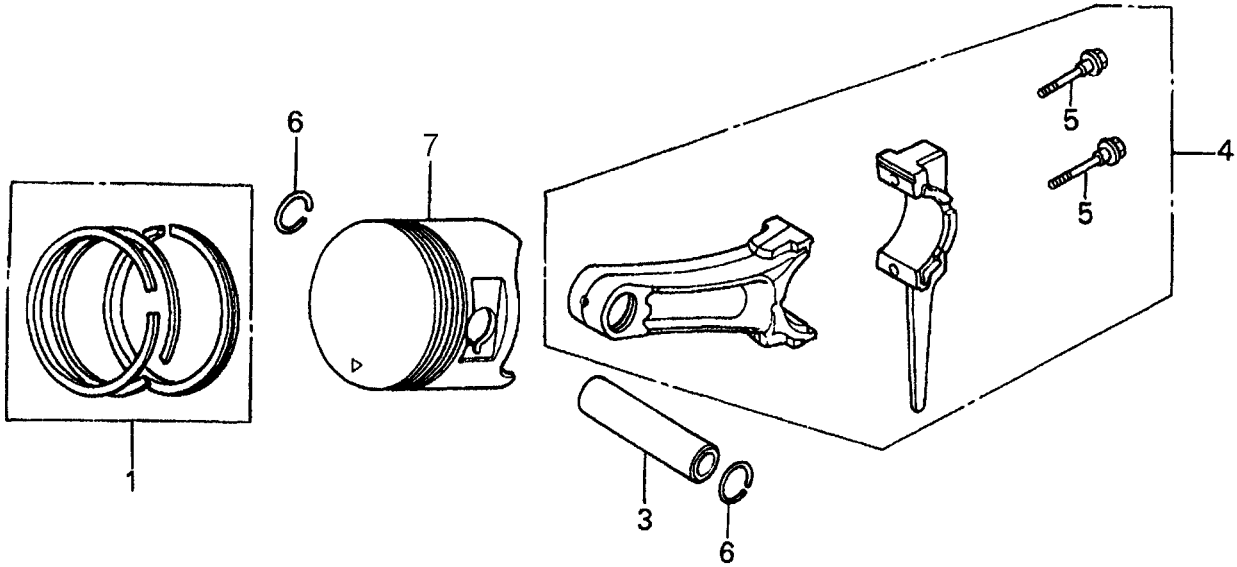

HONDA GX240RTEDN2 — PISTON ASSY.

<u>NO.</u>	<u>PART NO.</u>	<u>PART NAME</u>	<u>QTY.</u>	<u>REMARKS</u>
1	13010Z5K004	RING SET, PISTON (STD)	1	
1	13011Z5K004	RING SET, PISTON (0.25)	1	
1	13012Z5K004	RING SET, PISTON (0.50)	1	
1	13013Z5K004	RING SET, PISTON (0.75)	1	
3	13111Z5K000	PIN, PISTON	1	
4	13200Z1D000	ROD ASSY., CONNECTING (STD)	1.....	INCLUDES ITEMS W/@
4	13200Z10305	ROD ASSY., CONNECTING (0.25 UNDER SZ)	1	
5@	90001ZE8000	BOLT, CONNECTING ROD	2	
6	90551ZE1000	CUP, PISTON PIN 18MM	2	
7	13101Z5K000	PISTON (STD)	1	
7	13102Z5K000	PISTON (0.25)	1	
7	13103Z5K000	PISTON (0.50)	1	
7	13104Z5K000	PISTON (0.75)	1	

HONDA GX240RTEDN2 — RECOIL STARTER ASSY.

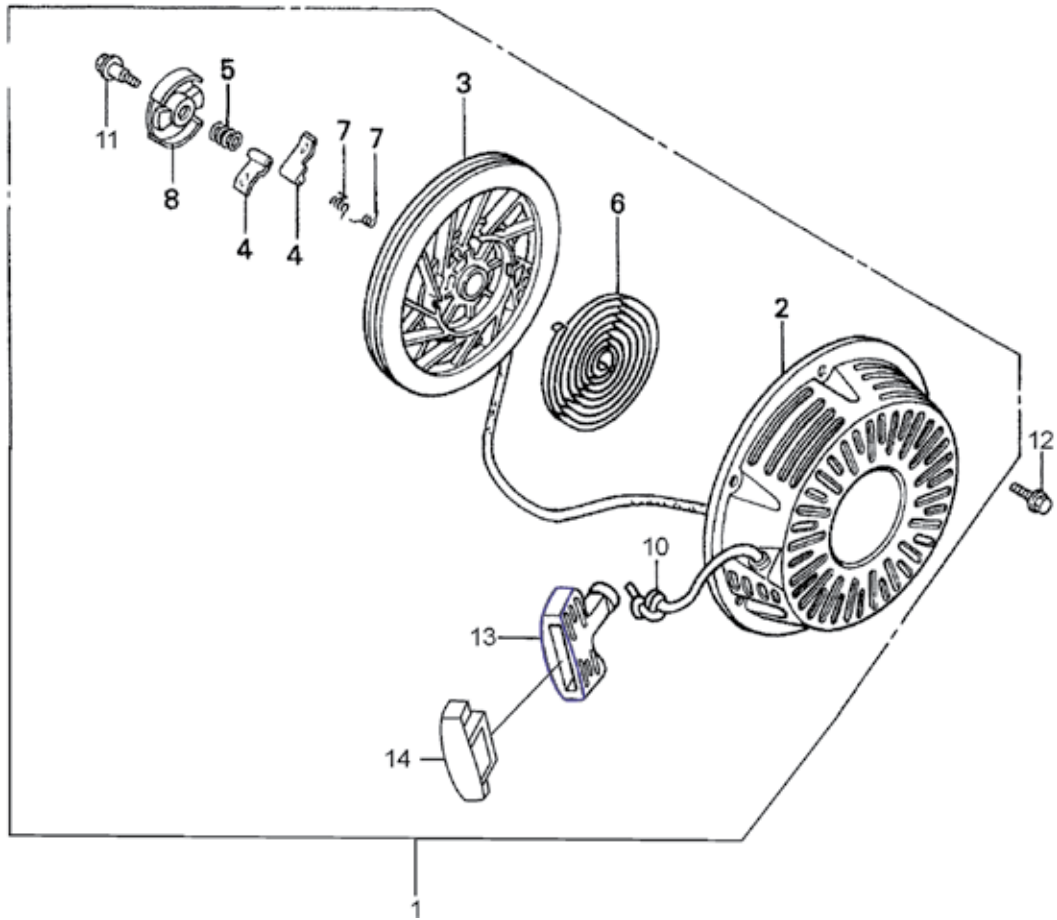

HONDA GX240RTEDN2 — RECOIL STARTER ASSY.

<u>NO.</u>	<u>PART NO.</u>	<u>PART NAME</u>	<u>QTY.</u>	<u>REMARKS</u>
1	28400Z5K013ZB	STARTER ASSY., RECOIL *NH1*	1.....	INCLUDES ITEMS W/%
2%	28410ZE2W01ZB	CASE COMP., RECOIL STARTER *NH1*	1	
3%	28421ZE2W01	PULLEY, RECOIL STARTER	1	
4%	28422ZE2W01	RATCHET, STARTER	2	
5%	28441ZE2W01	SPRING, FRICTION	1	
6%	28442ZE2W01	SPRING, STARTER RETURN	1	
7%	28443ZE2W01	SPRING, RATCHET	2	
8%	28444ZE2W01	RETAINER, SPRING	1	
10%	28462ZE2W11	ROPE, RECOIL STARTER	1	
11%	90004ZE2W01	SCREW, CENTER	1	
12	90008ZE2003	BOLT, FLANGE 6X10	3	
13%	28461Z5T305	GRIP, STARTER	1	
14%	28463Z5T013	GRIP, REINFORCEMENT	1	

HONDA GX240RT2EDN2 — SOLENOID ASSY.

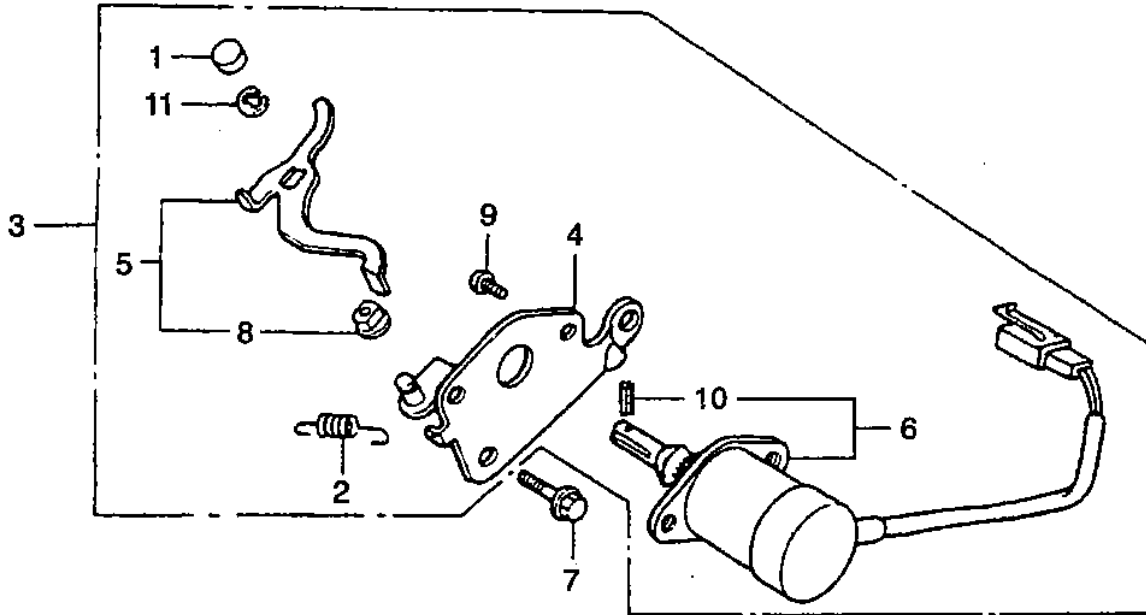

HONDA GX240RTEDN2 — SOLENOID ASSY.

<u>NO.</u>	<u>PART NO.</u>	<u>PART NAME</u>	<u>QTY.</u>	<u>REMARKS</u>
1#	16252ZA1010	CAP, CHOKE LEVER	1	
2#	16268893000	SPRING, CHOKE RETURN	1	
3	16270ZB4010	AUTO-THROTTLE ASSY.	1	INCLUDES ITEMS W/+
4#	16271ZB4000	STAY, SOLENOID THROTTLE	1	
5#	16273ZB4000	LEVER COMP., SOLENOID THROTTLE	1	
6#	36160ZB4013	SOLENOID ASSY.	1	
7	90013883000	BOLT, FLANGE 6X12	1	
8#	91502ZB4701	BUSH, AUTO-THROTTLE LEVER	1	
9#	93500050080A	SCREW, PAN 5X8	2	
10#	9430520062	PIN, SPRING 2X6	1	
11#	9454004018	E-RING, 4MM	1	

HONDA GX240RT2EDN2 — ENGINE DECALS ASSY.

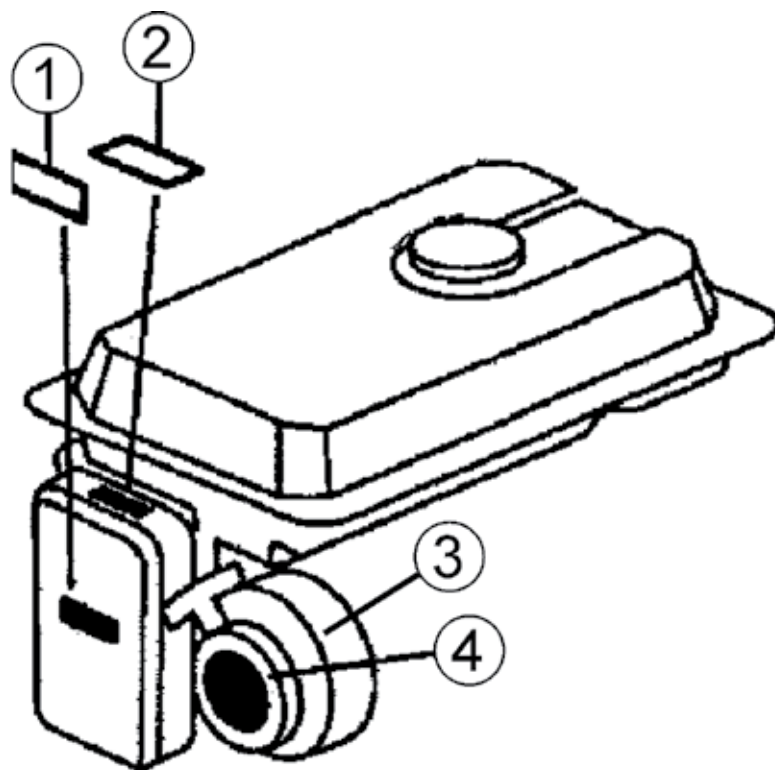

HONDA GX240RT2EDN2 — ENGINE DECALS ASSY.

<u>NO.</u>	<u>PART NO.</u>	<u>PART NAME</u>	<u>QTY.</u>	<u>REMARKS</u>
1	87533ZC0630	DECAL: AIR CLEANER (ENGLISH)	1	
2	87528898620	DECAL: CHOKE	1	
3	87594ZB4A00	DECAL: OIL CAUTION	1	
4	87521Z8S000	EMBLEM (GX240)	1	

TERMS AND CONDITIONS OF SALE — PARTS

PAYMENT TERMS

Terms of payment for parts are net 30 days.

FREIGHT POLICY

All parts orders will be shipped collect or prepaid with the charges added to the invoice. All shipments are F.O.B. point of origin. Multiquip's responsibility ceases when a signed manifest has been obtained from the carrier, and any claim for shortage or damage must be settled between the consignee and the carrier.

MINIMUM ORDER

The minimum charge for orders from Multiquip is \$15.00 net. Customers will be asked for instructions regarding handling of orders not meeting this requirement.

RETURNED GOODS POLICY

Return shipments will be accepted and credit will be allowed, subject to the following provisions:

1. A Returned Material Authorization must be approved by Multiquip prior to shipment.
2. To obtain a Return Material Authorization, a list must be provided to Multiquip Parts Sales that defines item numbers, quantities, and descriptions of the items to be returned.
 - a. The parts numbers and descriptions must match the current parts price list.
 - b. The list must be typed or computer generated.
 - c. The list must state the reason(s) for the return.
 - d. The list must reference the sales order(s) or invoice(s) under which the items were originally purchased.
 - e. The list must include the name and phone number of the person requesting the RMA.
3. A copy of the Return Material Authorization must accompany the return shipment.
4. Freight is at the sender's expense. All parts must be returned freight prepaid to Multiquip's designated receiving point.

5. Parts must be in new and resalable condition, in the original Multiquip package (if any), and with Multiquip part numbers clearly marked.
6. The following items are not returnable:
 - a. Obsolete parts. (If an item is in the price book and shows as being replaced by another item, it is obsolete.)
 - b. Any parts with a limited shelf life (such as gaskets, seals, "O" rings, and other rubber parts) that were purchased more than six months prior to the return date.
 - c. Any line item with an extended dealer net price of less than \$5.00.
 - d. Special order items.
 - e. Electrical components.
 - f. Paint, chemicals, and lubricants.
 - g. Decals and paper products.
 - h. Items purchased in kits.
7. The sender will be notified of any material received that is not acceptable.
8. Such material will be held for five working days from notification, pending instructions. If a reply is not received within five days, the material will be returned to the sender at his expense.
9. Credit on returned parts will be issued at dealer net price at time of the original purchase, less a 15% restocking charge.
10. In cases where an item is accepted, for which the original purchase document can not be determined, the price will be based on the list price that was effective twelve months prior to the RMA date.
11. Credit issued will be applied to future purchases only.

PRICING AND REBATES

Prices are subject to change without prior notice. Price changes are effective on a specific date and all orders received on or after that date will be billed at the revised price. Rebates for price declines and added charges for price increases will not be made for stock on hand at the time of any price change.

Multiquip reserves the right to quote and sell direct to Government agencies, and to Original Equipment Manufacturer accounts who use our products as integral parts of their own products.

SPECIAL EXPEDITING SERVICE

A \$35.00 surcharge will be added to the invoice for special handling including bus shipments, insured parcel post or in cases where Multiquip must personally deliver the parts to the carrier.

LIMITATIONS OF SELLER'S LIABILITY

Multiquip shall not be liable hereunder for damages in excess of the purchase price of the item with respect to which damages are claimed, and in no event shall Multiquip be liable for loss of profit or good will or for any other special, consequential or incidental damages.

LIMITATION OF WARRANTIES

No warranties, express or implied, are made in connection with the sale of parts or trade accessories nor as to any engine not manufactured by Multiquip. Such warranties made in connection with the sale of new, complete units are made exclusively by a statement of warranty packaged with such units, and Multiquip neither assumes nor authorizes any person to assume for it any other obligation or liability whatever in connection with the sale of its products. Apart from such written statement of warranty, there are no warranties, express, implied or statutory, which extend beyond the description of the products on the face hereof.

Effective: February 22, 2006

OPERATION AND PARTS MANUAL

HERE'S HOW TO GET HELP

PLEASE HAVE THE MODEL AND SERIAL
NUMBER ON-HAND WHEN CALLING

UNITED STATES

Multiquip Corporate Office

18910 Wilmington Ave.
Carson, CA 90746
Contact: mq@multiquip.com

Tel. (800) 421-1244
Fax (310) 537-3927

Service Department

800-421-1244
310-537-3700

Fax: 310-537-4259

Technical Assistance

800-478-1244

Fax: 310-943-2238

MQ Parts Department

800-427-1244
310-537-3700

Fax: 800-672-7877
Fax: 310-637-3284

Warranty Department

800-421-1244
310-537-3700

Fax: 310-943-2249

CANADA

Multiquip

4110 Industriel Boul.
Laval, Quebec, Canada H7L 6V3
Contact: jmartin@multiquip.com

Tel: (450) 625-2244
Tel: (877) 963-4411
Fax: (450) 625-8664

UNITED KINGDOM

Multiquip (UK) Limited Head Office

Unit 2, Northpoint Industrial Estate,
Globe Lane,
Dukinfield, Cheshire SK16 4UJ
Contact: sales@multiquip.co.uk

Tel: 0161 339 2223
Fax: 0161 339 3226

© COPYRIGHT 2014, MULTIQUIP INC.

Multiquip Inc, the MQ logo and the MQ Power logo are registered trademarks of Multiquip Inc. and may not be used, reproduced, or altered without written permission. All other trademarks are the property of their respective owners and used with permission.

This manual MUST accompany the equipment at all times. This manual is considered a permanent part of the equipment and should remain with the unit if resold.

The information and specifications included in this publication were in effect at the time of approval for printing. Illustrations, descriptions, references and technical data contained in this manual are for guidance only and may not be considered as binding. Multiquip Inc. reserves the right to discontinue or change specifications, design or the information published in this publication at any time without notice and without incurring any obligations.

Your Local Dealer is:

Manufactured for
Multiquip Inc.
by
DENYO CO., LTD, JAPAN

