



**Chicago Pneumatic Construction Tools**

# Safety and Operating instructions

**Chipping hammer CP 4123  
CP 4125**

- (FR)** Prescriptions de sécurité et instructions pour l'opérateur  
Marteau burineur
- (DE)** Sicherheitsvorschriften und Bedienungsanleitung  
Meißelhammer
- (ES)** Instrucciones de seguridad y de funcionamiento  
Martillo de cincelar
- (PT)** Instruções de segurança e operação  
Martellos raspadores
- (IT)** Istruzioni per la sicurezza e per l'uso  
Martello scalpellatore
- (NL)** Veiligheidsvoorschriften en bedieningshandleiding  
Breekhamer
- (GR)** Οδηγίες ασφάλειας και χειρισμού  
Ματσάκονι
- (FI)** Turvallisuusohjeet ja käyttöohje  
Piikkauskone-paineilmakanki
- (DK)** Sikkerhedsinstruktioner og betjeningsvejledning  
Mejselhammer
- (NO)** Sikkerhetsinstrukser og bruksanvisning  
Sveisehammer
- (SE)** Säkerhetsinstruktion och bruksanvisning  
Mejselhammare

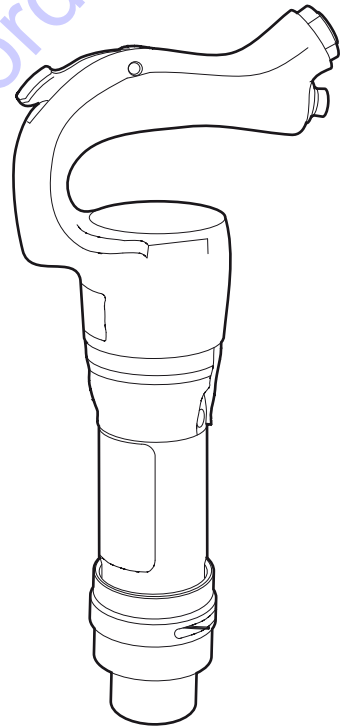

# PARTS FINDER

**Search Website  
by Part Number**



**Search Manual  
Library For Parts  
Manual & Lookup Part  
Numbers – Purchase  
or Request Quote**

**Search Manuals**

Enter your information to help us find the right parts manual for your machine.

\* Brand:

\* Model:

\* Serial:

\* Part Number:

SEARCH

**Can't Find Part or  
Manual? Request Help  
by Manufacturer,  
Model & Description**

**Parts Order Form**

Please fill in the following information to help us find the right part for your machine.

Manufacturer:	<input type="text"/>
Model:	<input type="text"/>
Description:	<input type="text"/>
Part Number:	<input type="text"/>
Quantity:	<input type="text"/>
Notes:	<input type="text"/>

Submit

Discount-Equipment.com is your online resource for quality parts & equipment.

Florida: **561-964-4949** Outside Florida TOLL FREE: **877-690-3101**

**Need parts?**

Click on this link: <http://www.discount-equipment.com/category/5443-parts/> and choose one of the options to help get the right parts and equipment you are looking for. Please have the machine model and serial number available in order to help us get you the correct parts. If you don't find the part on the website or on one of the online manuals, please fill out the request form and one of our experienced staff members will get back to you with a quote for the right part that your machine needs.

We sell worldwide for the brands: Genie, Terex, JLG, MultiQuip, Mikasa, Essick, Whiteman, Mayco, Toro Stone, Diamond Products, Generac Magnum, Airman, Haulotte, Barreto, Power Blanket, Nifty Lift, Atlas Copco, Chicago Pneumatic, Allmand, Miller Curber, Skyjack, Lull, Skytrak, Tsurumi, Husquvarna Target, Stow, Wacker, Sakai, Mi-T-M, Sullair, Basic, Dynapac, MBW, Weber, Bartell, Bennar Newman, Haulotte, Ditch Runner, Menegotti, Morrison, Contec, Buddy, Crown, Edco, Wyco, Bomag, Laymor, EZ Trench, Bil-Jax, F.S. Curtis, Gehl Pavers, Heli, Honda, ICS/PowerGrit, IHI, Partner, Imer, Clipper, MMD, Koshin, Rice, CH&E, General Equipment, Amida, Coleman, NAC, Gradall, Square Shooter, Kent, Stanley, Tamco, Toku, Hatz, Kohler, Robin, Wisconsin, Northrock, Oztec, Toker TK, Rol-Air, APT, Wylie, Ingersoll Rand / Doosan, Innovatech, Con X, Ammann, Mecalac, Makinex, Smith Surface Prep, Small Line, Wanco, Yanmar



Go to [Discount-Equipment.com](http://Discount-Equipment.com) to order your parts

**2008-02**

**No. 9800 0606 90**

© Copyright Chicago Pneumatic Construction Tools  
STOCKHOLM • SWEDEN



# Contents

<b>ENGLISH</b> .....	<b>4</b>
<b>FRANÇAIS</b> .....	<b>20</b>
<b>DEUTSCH</b> .....	<b>36</b>
<b>ESPAÑOL</b> .....	<b>52</b>
<b>PORTUGUÊS</b> .....	<b>68</b>
<b>ITALIANO</b> .....	<b>84</b>
<b>NEDERLANDS</b> .....	<b>100</b>
<b>ΕΛΛΗΝΙΚΑ</b> .....	<b>116</b>
<b>SUOMI</b> .....	<b>132</b>
<b>NORSK</b> .....	<b>148</b>
<b>DANSK</b> .....	<b>164</b>
<b>SVENSKA</b> .....	<b>180</b>

Go to [Discount-Equipment.com](http://Discount-Equipment.com) to order your parts



**ENGLISH****Contents**

<b>SAFETY INSTRUCTIONS</b> .....	6
Safety symbols used .....	6
Machine and tool operating hazards .....	6
Explosion and fire hazard .....	7
Electrical/Concealed object hazards .....	7
Projectile hazard .....	7
Noise hazard .....	8
Silica/Dust hazard .....	8
Vibration hazard .....	8
Machine modification hazard .....	9
Additional safety instructions .....	9
Protective equipment .....	10
Service and maintenance .....	10
Inserted tools .....	10
<b>Overview</b> .....	11
Design and function .....	11
Choosing the correct pneumatic hammer .....	11
Main parts .....	11
Stamps, signs and stickers .....	12
<b>Installation</b> .....	12
Hoses and connections .....	12
Methods to prevent freezing .....	12
Water separator .....	13
Lubrication .....	13
Inserted tool .....	13
<b>Operation</b> .....	14
Start and stop .....	14
Starting a cut .....	14
Operating .....	15
When taking a break .....	15
<b>Maintenance</b> .....	15
Checking for wear on the inserted tool .....	15
Every day .....	15
Three times a year(100 impact hours) .....	15
Assembly instructions .....	15
<b>Storage</b> .....	16
<b>Disposal</b> .....	16
<b>Troubleshooting</b> .....	16
<b>Technical data</b> .....	17
Machine data .....	17
Noise & vibration declaration statement .....	18
Additional vibration information .....	18
Noise and vibration data .....	18



## Introduction

Thank you for choosing Chicago Pneumatic as a supplier for tools and services.

Chicago Pneumatic is a global company offering a wide range of pneumatic and hydraulic tools that include breakers, rock drills, chipping hammers, clay-diggers, picks and busters, scabblers, pumps and a whole lot more.

In 2001 Chicago Pneumatic Tool Company celebrated 100 years as a pioneer and market-leader in the pneumatic tool industry. Chicago Pneumatic has always focused on providing powerful and reliable products that are easy to maintain and that give good value for money. It's a philosophy that has made us the market-leader for air tools in the USA.

Read more at [www.cp.com](http://www.cp.com)

## About the Safety and Operating Instructions

The aim of these instructions is to provide you with a full understanding of how to use the pneumatic hammer in an efficient, safe way. The instructions also give you advice and tell you how to perform regular maintenance on the pneumatic hammer.

Before using the pneumatic hammer for the first time you must read these instructions carefully and understand all of them.

Go to Discount-Equipment.com to order your parts



## SAFETY INSTRUCTIONS



To reduce the risk of serious injury or death to yourself or others, read these safety instructions before operating the machine.

Post these safety instructions at work locations, provide copies to employees, and make sure that everyone reads the safety instructions before operating or servicing the machine.

Comply with all safety regulations.

### Safety symbols used

The indications **Danger**, **Warning** and **Caution** have the following meanings:

- |   |  |
|---|--|
|  <b>Danger</b>   | <b>Indicates an imminently hazardous situation which, if not avoided, will result in death or serious injury.</b>  |
|  <b>Warning</b>  | <b>Indicates a potentially hazardous situation which, if not avoided, could result in death or serious injury.</b> |
|  <b>Caution</b> | <b>Indicates a potentially hazardous situation which, if not avoided, may result in minor or moderate injury.</b>  |

### Machine and tool operating hazards

#### **Warning**

Sudden or unexpected movement of the machine may occur during operation, which may cause injuries. Furthermore, losing your balance or slipping may cause injury. To reduce risks:

- › Make sure that you always keep a stable position with your feet as far apart as your shoulder width, and keeping a balanced body weight.
- › Stand firmly and always hold on to the machine with both hands.
- › Do not start the machine when it is lying on the ground.
- › Make sure that the handle is clean and free of grease and oil.

#### **Warning**

Unintended start of the machine may cause injury.

- › Keep your hands away from the start and stop device until you are about to start work.

#### **Warning**

The inserted tool is exposed to heavy strains when the machine is used and after a certain amount of use the tool may break due to fatigue. If the tool breaks, there may be sudden or strong movements. Such sudden or strong movements may cause serious injury.

- › Make sure that you always keep a stable position with your feet as far apart as your shoulder width, and keeping a balanced body weight.
- › Keep your hands and feet away from the inserted tool.
- › Check regularly for wear to the inserted tool, and check whether there are any signs of damage or visible cracks.

#### **Warning**

An incorrect dimension of the inserted tool's shank can result in the inserted tool being lost or slipping out during operation. An inserted tool that is lost or slips out can cause personal injury.

- › Before inserting the work tool, make sure that the shank's dimensions are the ones that should be used in the machine.
- › Inserted tools without a collar may not be used.

#### **Warning**

If the cap is not fitted, the inserted tool can be ejected with force, which can cause personal injury.

- › Once the inserted tool has been mounted and the cap fitted, the locking function must be checked by pulling the inserted tool outwards sharply.
- › Make sure that the inserted tool is fully inserted and the cap tightened to its end position and locked by the O-ring before the machine is started.
- › Never point the inserted tool at yourself or anyone else.





## **⚠ Warning**

Starting the machine while changing the inserted tool may cause personal injury.

- › Before changing the tool, stop the machine, switch off the compressed air supply and bleed the machine by activating the start and stop device.

## **⚠ Warning**

A compressed air hose that comes loose can lash around and cause personal injury or death.

To reduce risks:

- › Check that the compressed air hose and the connections are not damaged.
- › Check that all compressed air connections are properly attached.
- › Never attempt to disconnect a compressed air hose that is pressurized. First switch off the compressed air by the compressor and then bleed the machine by activating the start and stop device.

## **Explosion and fire hazard**

---

### **⚠ Warning**

Breaking, hammering and working with certain materials can cause sparks, which may ignite explosive gases and cause explosions. Explosions may cause serious injury or death.

To reduce such risk of explosion:

- › Never operate the machine in any explosive environment.
- › Do not use the machine near flammable materials, fumes or dust.
- › Make sure that there are no undetected sources of gas.

## **Electrical/Concealed object hazards**

---

### **⚠ Warning**

The machine is not electrically insulated. If the machine comes into contact with electricity, serious injuries or death may result.

- › To reduce the risk of such injury or death, never operate the machine near any electric wire or other source of electricity.
- › Make sure that there are no concealed wires or other sources of electricity.

### **⚠ Warning**

During breaking, concealed wires and pipes constitute a danger that can result in serious injury.

- › Before you start breaking, check the composition of the material you are to work on.
- › Watch out for concealed cables and pipes e.g. electricity, telephone, water, gas and sewage lines etc.
- › If the tool seems to have hit a concealed object, switch off the machine immediately.
- › Make sure that there is no danger before continuing.

## **Projectile hazard**

---

### **⚠ Warning**

During breaking or hammering, splinters or other particles from the worked material may become projectiles and cause personal injury by striking the operator or other persons.

- › Use approved personal protective equipment, including impact resistant safety glasses with side protection, to reduce the risk of being injured by a projectile.





## Noise hazard

---

### Warning

High sound levels may cause permanent hearing loss.

- › Use hearing protection in accordance with occupational health and safety regulations.

## Silica/Dust hazard

---

### Warning

Exposure to crystalline silica (sometimes called 'silica dust') as a result of breaking, hammering, or other activities involving rock, concrete, asphalt or other materials may cause silicosis (a serious lung disease), silicosis-related illnesses, cancer, or death. Silica is a major component of rock, sand and mineral ores.

To reduce silica exposure:

- › Use proper engineering controls to reduce the amount of silica in the air and the build-up of dust on equipment and surfaces. Examples of such controls include: exhaust ventilation, dust collection systems and water sprays. Make sure that controls are properly installed and maintained.
- › Wear, maintain, and correctly use approved particulate respirators when engineering controls alone are not adequate to reduce exposure below permissible levels.
- › Participate in air monitoring, medical exams, and training programs offered by your employer and when required by law.
- › Wear washable or disposable protective clothes at the worksite; shower and change into clean clothes before leaving the worksite to reduce exposure of silica to yourself, other persons, cars, homes, and other areas.
- › Do not eat, drink, or use tobacco products in areas where there is dust containing crystalline silica.
- › Wash your hands and face before eating, drinking, or using tobacco products outside of the exposure area.
- › Work with your employer to reduce silica exposure at your worksite.

### Warning

Some dust, fumes or other airborne material created during use of the machine may contain chemicals known to the State of California to cause cancer and birth defects or other reproductive harm. Some examples of such chemicals are:

- › Crystalline silica and cement and other masonry products.
- › Arsenic and chromium from chemically-treated rubber.
- › Lead from lead based paints.

To reduce your exposure to these chemicals, work in a well ventilated area, and work with approved safety equipment, such as dust masks that are specially designed to filter out microscopic particles.

## Vibration hazard

---

### Warning

Normal and proper use of the machine exposes the operator to vibration. Regular and frequent exposure to vibration may cause, contribute to, or aggravate injury or disorders to the operator's fingers, hands, wrists, arms, shoulders and/or other body parts, including debilitating and/or permanent injuries or disorders that may develop gradually over periods of weeks, months, or years. Such injury or disorder may include damage to the blood circulatory system, damage to the nervous system, damage to joints, and possibly damage to other body structures.

If numbness, tingling, pain, clumsiness, weakened grip, whitening of the skin, or other symptoms occur at any time, when operating the machine or when not operating the machine, do not resume operating the machine and seek medical attention. Continued use of the machine after the occurrence of any such symptom may increase the risk of symptoms becoming more severe and/or permanent.

The following may help to reduce exposure to vibration for the operator:

- › Let the tool do the job. Use a minimum hand grip consistent with proper control and safe operation.



- › When the percussion mechanism is activated, the only body contact with the machine you should have is your hands on the handles. Avoid any other contact, e.g. supporting any part of the body against the machine or leaning onto the machine trying to increase the feed force. It is also important not to keep the trigger engaged while extracting the tool from the broken work surface.
- › Make sure that the inserted tool is well-maintained (including sharpness, if a cutting tool), not worn out, and of the proper size. Inserted tools that are not well-maintained, or that are worn out, or that are not of the proper size result in longer time to complete a task (and a longer period of exposure to vibration) and may result in or contribute to higher levels of vibration exposure.
- › Stop working Immediately if the machine suddenly starts to vibrate strongly. Before resuming the work, find and remove the cause of the increased vibrations.
- › Comply with the recommended air-pressure when operating the machine. Either higher or lower air-pressure has the potential of resulting in higher levels of vibration.
- › Do not grab, hold or touch the inserted tool when using the machine.
- › Participate in health surveillance or monitoring, medical exams, and training programs offered by your employer and when required by law.

**Note!** See the “Noise & vibration declaration statement” for the machine, including the declared vibration values and “Additional vibration information”. These can be found at the end of the Safety and Operating instructions.

## Machine modification hazard

### Warning

Any machine modification not approved by Chicago Pneumatic may result in serious injuries to yourself or others.

- › **The machine must not be modified without Chicago Pneumatic's permission.**
- › **Use only original parts and accessories approved by Chicago Pneumatic.**

## Additional safety instructions

- › Machines and accessories must only be used for their intended purpose.
- › Only qualified and trained persons may operate or maintain the machine.
- › Learn how the machine is switched off in the event of an emergency.
- › The maximum permissible air pressure for the machine must not be exceeded.
- › Release the start and stop device immediately in all cases of power supply interruption.
- › Always inspect the equipment prior to use. Do not use the equipment if you suspect that it is damaged.
- › Always use your common sense and good judgment.
- › Pay attention and look at what you are doing.
- › Do not use the machine when you are tired or under the influence of drugs, alcohol or anything else that may affect your vision, reactions or judgment.
- › Participate in safety and training courses.
- › Never strike or abuse any equipment.
- › Keep the machine and tools in a safe place, out of the reach of children and locked up.
- › Make sure that all the attached and related equipment is properly maintained.
- › Signs and stickers bearing important information regarding personal safety and care of the machine are supplied with every machine. Make sure that the signs are always legible. New signs and stickers can be ordered from the spare parts list.
- › Make sure that no unauthorized personnel trespass into the working zone.
- › Keep the workplace clean and free from foreign objects.
- › Never point a compressed air hose at yourself or anyone else. To avoid the risk of getting injured, never use compressed air to blow e.g. dust, dirt etc. from your clothes.



## Protective equipment

---

Always use approved protective equipment. Operators and all other persons in the working area must wear protective equipment, including at a minimum:

- › Protective helmet
- › Hearing protection
- › Impact resistant eye protection with side protection
- › Respiratory protection when appropriate
- › Protective gloves
- › Protective boots

## Service and maintenance

---

Regular maintenance is a prerequisite for keeping the machine safe and effective. Carefully follow the operating instructions.

Before undertaking any maintenance or changing the inserted tool on pneumatic machines, always switch off the air supply and bleed the machine by depressing the start and stop device. Then disconnect the air hose from the machine.

- › **Use only authorized parts. Any damage or malfunction caused by unauthorized parts will not be covered by Warranty or Product Liability.**
- › Change damaged parts immediately.
- › Replace damaged and worn components in good time.
- › For major service to the machine, contact your nearest authorized workshop.
- › When cleaning mechanical parts with solvents, make sure to comply with current health and safety regulations and that there is satisfactory ventilation.

## Inserted tools

---

- › Keep the tools clean and in good condition. Regularly check the inserted tools, make sure that they are sharp and not worn out.

**Note!** The machine can be destroyed if you use incorrect inserted tools.





## Overview

To reduce the risk of serious injury or death to yourself or others, read the Safety instructions section found on the previous pages of this manual before operating the machine.

## Design and function

CP 4123 is a pneumatic tool designed for rugged use in foundries, fabrication shops and construction applications. The different stroke versions offer the power levels necessary for a variety of applications, from light to medium chipping and trimming through heavy cutting. The machine can be used both horizontally and vertically. No other use is permitted.

CP 4125 is a pneumatic tool designed for rugged use in foundries, shipyards, refineries, fabrication shops and construction applications. The 22" to 4" stroke versions offer the power levels necessary for a variety of applications from light to medium chipping and trimming through heavy cutting. The machine can be used both horizontally and vertically. No other use is permitted.

## Choosing the correct pneumatic hammer

It is important to choose the correct size of pneumatic hammer for the work to be performed. A pneumatic hammer that is too small means that the work will take longer.

A hammer that is too large means that there must be frequent repositioning, which is unnecessarily tiring for the operator.

A simple rule for choosing the correct size of pneumatic hammer is that a normal sized piece of broken material should be removed from the workpiece within 5-10 seconds of operation.

- › If it takes less than 5 seconds a smaller pneumatic hammer should be selected.
- › If it takes more than 10 seconds a larger pneumatic hammer should be selected.

## Main parts

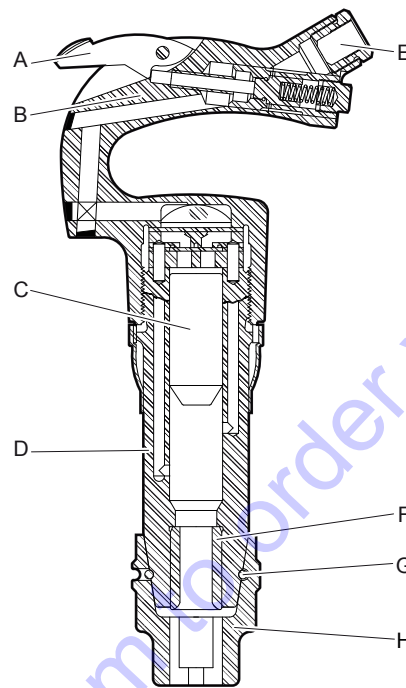

- A. Trigger
- B. Handle
- C. Piston
- D. Cylinder
- E. Air intake
- F. Tool bushing
- G. Lock coil
- H. Retainer

## Stamps, signs and stickers

Signs and stickers with important information about personal safety and machine care are mounted on the machine. The signs and stickers must always be legible. New signs and stickers can be ordered from the spare parts list.

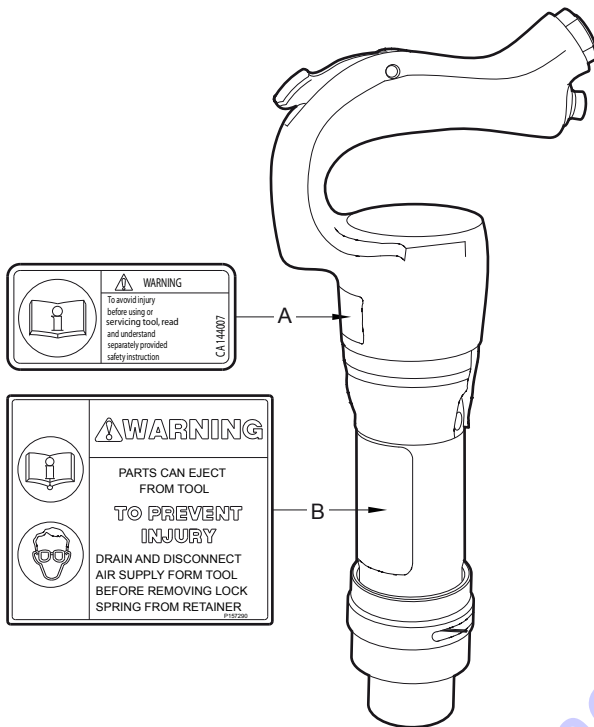

- The warning symbol together with the book symbol means that the user must read the Safety and Operating instructions before the machine is used for the first time.
- The sign informs the operator of the following:  
Before changing the tool, stop the machine, switch off the compressed air supply and bleed the machine by activating the start and stop device. Use approved personal protective equipment, including impact resistant safety glasses with side protection, to reduce the risk of being injured by a projectile.

## Installation

### Hoses and connections

#### Connections between the compressed air source and the machine

- Select the correct dimension and length for the compressed air hose. For hose lengths up to 100 feet (30 m), use a hose with a minimum internal diameter of 3/4 in. (19 mm). If the hose length is between 100 and 300 feet (30-100 m), use a hose with a minimum internal diameter of 1 in. (25 mm).
- Blow any impurities out of the compressed air hose before connecting it to the machine.
- Check that you are using the correct recommended operating pressure, 6 bar (e).

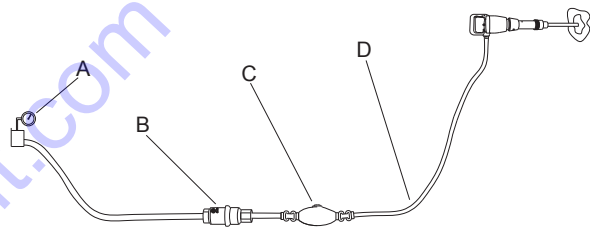

- Compressed air source
- Water separator (optional)
- Lubricator (optional)
- Max. 10 feet (3 m) compressed air hose between the lubricator and the machine.

### Methods to prevent freezing

Ice formation in the muffler can occur when the ambient air temperature is 32-50 °F (0-10 °C) and the relative humidity is high.

The machine is designed to avoid the formation of ice in the muffler. Despite this, under extreme conditions ice can form in the muffler.

The following actions can be taken to further counteract the risk of ice formation:

- Use an air tool oil containing antifreeze agents.
- Use a water separator.



## Water separator

The length of the air hose between the compressor and the water separator must be such that the water vapor is cooled and condenses in the hose before reaching the water separator.

The required hose length is dependant on the ambient temperature and the relative humidity. If the ambient temperature is below 32 °F (0 °C) the hose must be short enough to prevent the water from freezing before reaching the water separator.

## Lubrication

The lubricant is important for the machine's function and has a great impact on the service life. In order to supply the correct volume of oil, a lubricator should be connected to the air hose. The use of the Chicago Pneumatic Air Line Lubricator is recommended. To guarantee good lubrication, the length of the air hose between the lubricator and the pneumatic hammer should not exceed 10 feet (3 m).

Too much lubrication may cause starting problems, low power or uneven performance.

Recommended Lubricant: Air tool oil with a viscosity of 100-150 SUS at 100°F (ISO VG 22–32). It is recommended that the oil contains a rust-inhibitor.

## Inserted tool

### Choosing inserted tool

A correct inserted tool is a condition for good operation. To avoid unnecessary machine damage, it is important to choose inserted tools with a high quality.

Recommended inserted tools are listed in the machine's spare parts list.

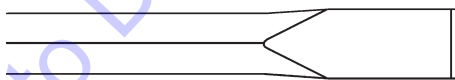

*The narrow chisel should be used for demolition and cutting work in concrete and other types of hard material.*



*The moil point should only be used for creating holes in concrete and other types of hard material.*

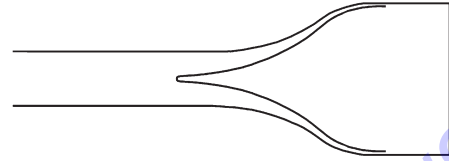

*The wide chisel should be used in soft materials e.g. plaster and removal of tiles.*

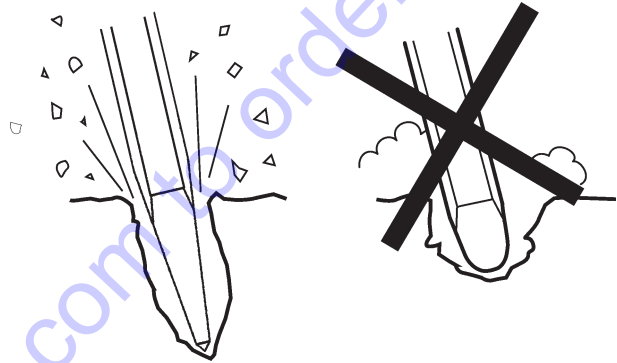

Always use a sharp tool to be able to work effectively. A worn out tool causes increased vibrations and the operation will take longer.

### Fitting and removing the inserted tool

#### ⚠ Warning

Starting the machine while changing the inserted tool may cause personal injury. Before changing the tool, stop the machine, switch off the compressed air supply and bleed the machine by activating the start and stop device.

Whenever fitting the inserted tool the following instructions must be observed:

- › Before inserting a tool, lubricate the tool shank with grease.
- › When the tool is inserted, fit the cap and check the lock function by pulling the inserted tool sharply outwards.



### Standard retainer, oval collar chisels, hexagonal shank

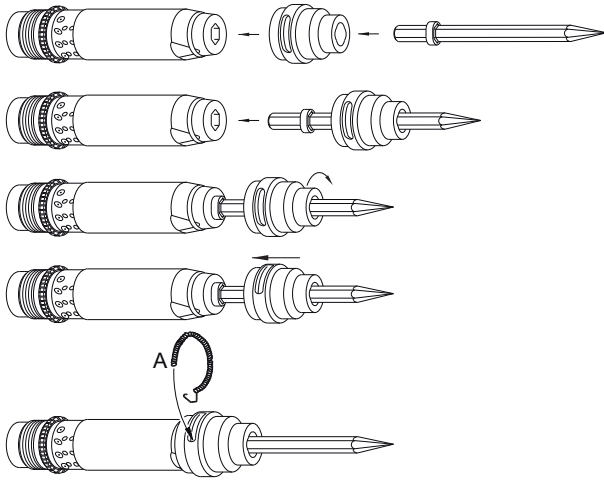

1. Slide the chisel shank into the oval retainer hole.
2. Insert the chisel shank into the tool bushing.
3. Rotate and lock the retainer on to the chisel.
4. Slide the retainer on to the cylinder.
5. Lock the retainer by inserting the lock coil (A).

### Standard retainer, oval collar chisels, round shank

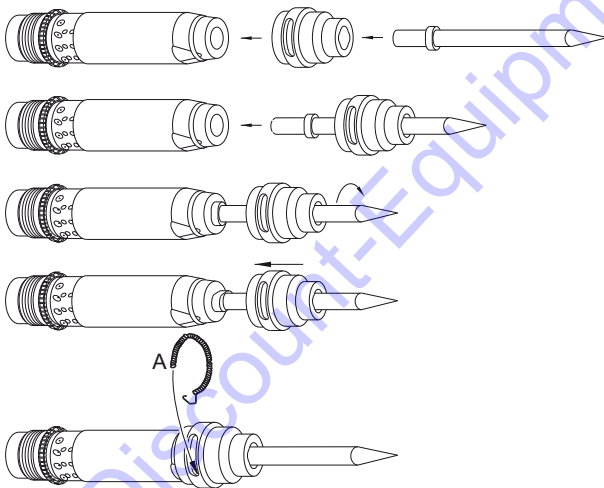

1. Slide the chisel shank into the oval retainer hole.
2. Insert the chisel shank into the tool bushing.
3. Rotate and lock the chisel into the retainer.
4. Slide the retainer on to the cylinder.
5. Lock the retainer by inserting the lock coil (A).

## Operation

### Start and stop

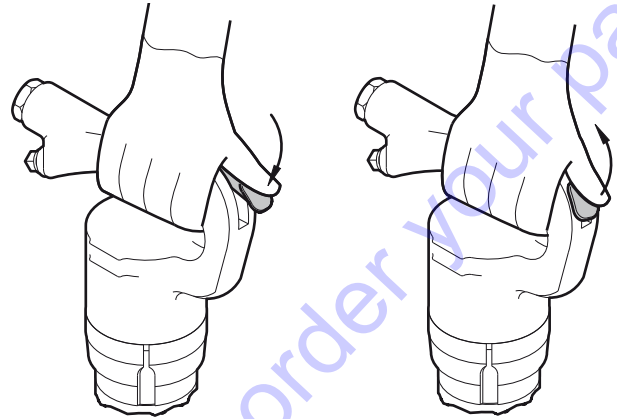

- › Start the machine by squeezing the trigger while firmly holding the handle.
- › Stop the machine by releasing the trigger. The trigger will then return to its original position.

### Starting a cut

- › Stand steady and make sure that your feet and hands are at a safe distance from the inserted tool.
- › Press the machine against the surface of the workpiece before starting.
- › Adjust the breaking distance (A) so that the inserted tool does not get stuck.

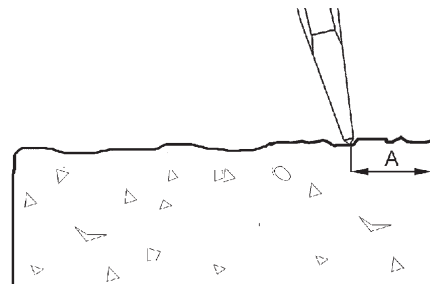

- › Do not try to cut too big a bite.
- › Trying to loosen an inserted tool that is stuck will expose the operator to unnecessary vibrations.



## Operating

- › Let the machine do the work; do not press too hard.
- › Avoid working in extremely hard materials e.g. granite and reinforcing iron (reinforcement bar) which would cause substantial vibrations.
- › Any form of idling, operating without inserted tool or operating without feed force adapted must be avoided.
- › When no feed force is adapted, the start and stop device must not be activated.
- › Check regularly that the machine is well lubricated.

## When taking a break

- › During all breaks you must put the machine away in such a way that there is no risk of it being unintentionally started.
- › In event of a longer break or when leaving the workplace: Switch off the compressed air supply and then bleed the machine by activating the start and stop device.

## Maintenance

Regular maintenance is a fundamental condition for the machine to continue to be a safe and efficient tool.

## Checking for wear on the inserted tool

Using an inserted tool with a worn out shank leads to increased machine vibration. To avoid increased vibrations, check the shank for wear before the inserted tool is fitted in the machine.

## Every day

- › Clean and inspect the machine.
- › Check the tool retainer for wear and function.
- › Conduct a general inspection for leaks and damage.
- › Check that the air inlet nipple is tightened and that the claw coupling is free from damage.

### For the machine to maintain the specified vibration values, always check the following:

- › Too large a clearance between the inserted tool's shank and the chisel bushing will generate increased vibrations. To avoid exposure to excessive vibrations, check the chisel bushing for wear every day.

## Three times a year (100 impact hours)

After each operating period of approximately 100 impact hours or 3 times a year the machine must be dismantled and all parts be cleaned and checked. This work must be performed by authorized staff, trained for this task.

## Assembly instructions

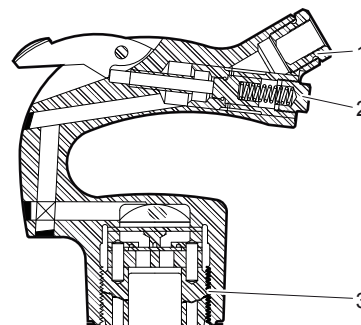

1. Torque: 50-60 lbf/ft (68-81 Nm), use Loctite 243.
2. Torque: 35-40 lbf/ft (47-54 Nm).
3. Torque: 400 lbf/ft (542 Nm).



## Storage

- › Make sure that the machine is properly cleaned before storage.
- › Pour approximately 2 oz. (5 cl) of oil directly into the air inlet nipple, connect the machine to the compressed air supply and run it for a few seconds.
- › Always store the machine in a dry place.

## Disposal

A used machine must be treated and disposed of in such a way that the greatest possible portion of the material can be recycled and any negative influence on the environment is kept as low as possible.

## Troubleshooting

If the pneumatic hammer does not start, has low power or uneven performance, check the following points.

- › Check that the inserted tool being used has the correct shank dimension.
- › Check that the pneumatic hammer is receiving the correct amount of lubricant. Too much lubrication can cause starting problems, low power or uneven performance.
- › Check that the compressed air system supplies the machine with sufficient air pressure to provide full power.
- › Check that the dimension and length of the air hose is in accordance with the recommendations. See "Installation".
- › If there is a risk of freezing, check that the machine's exhaust ports are not blocked.
- › If the machine function is still not satisfactory after this procedure, contact an authorized service workshop.





## Technical data

### Machine data

Model	Part No.	Weight lb (kg)	Length in. (mm)	Impact freq. Hz	Air Consumption foot <sup>3</sup> /min (l/s)	Shank in. (mm)
CP 4123 2H	8900 0001 05	15 (6.9)	14¾" (375)	37	25 (12)	H .580 (14.7)
CP 4123 2R	8900 0001 04	15 (6.9)	14¾" (375)	37	25 (12)	R .680 (17.3)
CP 4123 3H	8900 0001 07	17 (7.5)	16¾" (425)	30	30 (14)	H .580 (14.7)
CP 4123 3R	8900 0001 06	17 (7.5)	16¾" (425)	30	30 (14)	R .680 (17.3)
CP 4123 4H	8900 0001 09	18 (8.1)	18½" (460)	24	28 (13)	H .580 (14.7)
CP 4123 4R	8900 0001 08	18 (8.1)	18½" (460)	24	28 (13)	R .680 (17.3)
CP 4125 2H	8900 0001 11	15 (6.8)	15" (380)	32	28 (13)	H .580 (14.7)
CP 4125 2R	8900 0001 10	15 (6.8)	15" (380)	32	28 (13)	R .680 (17.3)
CP 4125 3H	8900 0001 13	16 (7.4)	16¾" (415)	28	32 (15)	H .580 (14.7)
CP 4125 3R	8900 0001 12	16 (7.4)	16¾" (415)	28	32 (15)	R .680 (17.3)
CP 4125 4H	8900 0001 15	18 (8.0)	17½" (445)	24	28 (13)	H .580 (14.7)
CP 4125 4R	8900 0001 14	18 (8.0)	17½" (445)	24	28 (13)	R .680 (17.3)

All data at 6 bar (e)



## Noise & vibration declaration statement

Vibration value **A** and uncertainty **B** in accordance with EN ISO 8662-5. Please see table “Noise and vibration data” for values A, B, etc.

These declared values were obtained by laboratory type testing in accordance with the stated directive or standards and are suitable for comparison with the declared values of other tools tested in accordance with the same directive or standards. These declared values are not adequate for use in risk assessments and values measured in individual work places may be higher. The actual exposure values and risk of harm experienced by an individual user are unique and depend upon the way the user works, in what material the machine is used, as well as upon the exposure time and the physical condition of the user, and the condition of the machine.

We, Chicago Pneumatic, cannot be held liable for the consequences of using the declared values, instead of values reflecting the actual exposure, in an individual risk assessment in a work place situation over which we have no control.

## Additional vibration information

This tool may cause hand-arm vibration syndrome if its use is not adequately managed.

This additional vibration information may be of assistance to employers in meeting their obligations (for example under EU Directive 2002/44/EC) to assess the risks to their workers arising from hand arm vibration associated with the use of this tool.

The vibration emission varies greatly with task and operator technique. The declared vibration value relates to a single axis on the D-handle and much higher vibration levels may occur at other hand positions or measurement directions.

We recommend a programme of health surveillance to detect early symptoms that may relate to vibration exposure, so that management procedures can be modified to help prevent significant disability.

## Noise and vibration data

		Vibration values	
		Single axis values	
		Declared	
		ISO 8662-5	
	<b>A</b> m/s <sup>2</sup> value	<b>B</b> m/s <sup>2</sup> spreads	
CP 4123	13	6	
CP 4125	13	6	



[www.discount-equipment.com](http://www.discount-equipment.com)

# PARTS FINDER

**Search Website  
by Part Number**



**Search Manual  
Library For Parts  
Manual & Lookup Part  
Numbers – Purchase  
or Request Quote**

**Search Manuals**

Enter your information to help us find the right parts manual for your machine.

\* Brand:

\* Model:

\* Serial:

\* Part Number:

SEARCH

**Can't Find Part or  
Manual? Request Help  
by Manufacturer,  
Model & Description**

**Parts Order Form**

Please fill in the following information to help us find the right part for your machine.

Manufacturer:	<input type="text"/>
Model:	<input type="text"/>
Description:	<input type="text"/>
Part Number:	<input type="text"/>
Quantity:	<input type="text"/>
Notes:	<input type="text"/>

Discount-Equipment.com is your online resource for quality parts & equipment.

Florida: **561-964-4949** Outside Florida TOLL FREE: **877-690-3101**

**Need parts?**

Click on this link: <http://www.discount-equipment.com/category/5443-parts/> and choose one of the options to help get the right parts and equipment you are looking for. Please have the machine model and serial number available in order to help us get you the correct parts. If you don't find the part on the website or on one of the online manuals, please fill out the request form and one of our experienced staff members will get back to you with a quote for the right part that your machine needs.

We sell worldwide for the brands: Genie, Terex, JLG, MultiQuip, Mikasa, Essick, Whiteman, Mayco, Toro Stone, Diamond Products, Generac Magnum, Airman, Haulotte, Barreto, Power Blanket, Nifty Lift, Atlas Copco, Chicago Pneumatic, Allmand, Miller Curber, Skyjack, Lull, Skytrak, Tsurumi, Husquvarna Target, Stow, Wacker, Sakai, Mi-T-M, Sullair, Basic, Dynapac, MBW, Weber, Bartell, Bennar Newman, Haulotte, Ditch Runner, Menegotti, Morrison, Contec, Buddy, Crown, Edco, Wyco, Bomag, Laymor, EZ Trench, Bil-Jax, F.S. Curtis, Gehl Pavers, Heli, Honda, ICS/PowerGrit, IHI, Partner, Imer, Clipper, MMD, Koshin, Rice, CH&E, General Equipment, Amida, Coleman, NAC, Gradall, Square Shooter, Kent, Stanley, Tamco, Toku, Hatz, Kohler, Robin, Wisconsin, Northrock, Oztec, Toker TK, Rol-Air, APT, Wylie, Ingersoll Rand / Doosan, Innovatech, Con X, Ammann, Mecalac, Makinex, Smith Surface Prep, Small Line, Wanco, Yanmar