



IMPORTANT!



READ THIS MANUAL BEFORE OPERATING MACHINE.

OPERATOR'S HANDBOOK, MAINTENANCE, SERVICE &

PARTS MANUAL

TERRAMITE CORPORATIONS

SINCE 1965



STREET SWEEPERS

TSS6 & TSS8



MADE IN THE USA



"Backed by a World of Experience"

600 Goff Mountain Road • P.O. Box 7146, Charleston, WV 25356-7146 USA
1.800.428.3772 Fax 1.800.776.4845 • International 1.304.776.4231 Fax 1.304.776.4845

www.terramite.com

Revised 02/2007

Table of Contents

SECTION ONE: INTRODUCTION/INFORMATION

Table of Contents 1.1

SECTION TWO: SAFETY GUIDELINES, MACHINE OPERATION AND SERVICE

Safety Guidelines, Machine Operation and Service 2.1
 Safety Guidelines 2.2 to 2.4
 When Operating The Street Sweeper 2.5
 Hazards and Hazardous Areas 2.5
 Transporting the Street Sweeper with a Trailer 2.6
 Towing the Street Sweeper 2.7 to 2.8
 Storing the Street Sweeper 2.9
 Engine Operating Instructions 2.9 to 2.10
 Weather Considerations 2.10
 Periodic Service 2.11
 Engine Oil Service 2.11
 Hydraulic System Service 2.12
 Street Sweeper Lubrication 2.13
 Battery and Tires 2.13
 Paint and Cleaning 2.13 to 2.14
 Trouble Shooting 2.14 to 2.15
 Machine Operation Control Location 2.15 to 2.16
 Lubrication and Maintenance Chart 2.16 to 2.17
 Service and Maintenance Points 2.17
 Machine Trouble Shooting & Hydraulic Component Check-Out 2.17
 Proper Care and Use of Broom Wafers 2.18
 Broom Core Removal/Wafer Replacement 2.19
 Setting and Adjusting Broom 2.20

SECTION THREE: PARTS

Operator's Position & Wafers 3.1
 View from Right Side of Operator's Position 3.2
 View from Left Side of Operators Position 3.3
 View of Front with Tow Bar Extended 3.4
 View of Tow Bar in Detail 3.5
 View of Lower Front 3.6
 View of Front 3.7
 View of Right Front 3.8
 View of Right Side Front 3.9
 View of Right Side Front 3.10
 View of Left Side Front 3.11
 View of Left Side 3.12
 View of Right Side Brush Assembly 3.13
 View of Left Side Brush Assembly 3.14
 View of Lower Right 3.15
 View of Lower Left 3.16
 View of Dash 3.17
 View of Under Dash 3.18
 View of Behind Dash 3.19
 View of Underside of Dash 3.20
 View from Back of Operator's Seat Left Side 3.21
 View from Inside Rear Panel 3.22
 View of Rear Engine Area 3.23
 Rear View of Transmission/Pump Assembly 3.24
 Left Side View of Transmission/Pump Assembly 3.25
 View of Under Seat Area 3.26
 View of Lock Out & Left Side Brush Assembly 3.27
 Front Fork Assembly 3.28
 Water System Routing 3.29
 Sprayer Parts 3.30
 Brush Core 3.31
 Front Hub 3.32
 Pivot Bearing Weldment Assembly 3.33
 Broom Mount Weldment 3.34
 Brush Bar Assembly 3.35
 Brush Bar Cylinder 3.36

Brush Core Motor Mount 3.37
 Brush Core Plate & Block For Motor Assembly 3.38
 Spray Bar Assembly 3.39
 Brake Hub Assembly 3.40
 Brake Hub Assembly 3.41
 Hoses Set Sweeper Parker Valves 3.42
 Hose Set Sweeper Saver Dantoss Valves 3.43
 Hoses 6 ft. Sweeper 3.44
 Low Pressure Filter Assembly & High Pressure 3.45
 Ground Drive Assembly 3.46
 Gear Pump Part # 66000 Gas/66001 Diesel 3.47
 Hyrdastatic Transmission 3.48
 Hyrdastatic Transmission 3.49
 110A Brush Motor Exploded View Parker 3.50
 Kubota Engine 3.51
 Hydraulic Oil Change and Type Specifications 3.52

SECTION FOUR: HYDRAULICS

Hyraulic Schematic #1, Main Propel Drive V1 4.1
 Hyraulic Schematic #2, Steering/Auxiliary V1 4.2
 Hyraulic Schematic #3, Broom Drive V1 4.3
 Hyraulic Schematic #1, Main Propel Drive V2 4.4
 Hyraulic Schematic #2, Steering/Auxiliary V2 4.5
 Hyraulic Schematic #3, Broom Drive V2 4.6
 Hyraulic Schematic #1, Main Propel Drive V3 4.7
 Hyraulic Schematic #2, Steering/Auxiliary V3 4.8
 Hyraulic Schematic #3, Broom Drive V3 4.9
 Wiring Diagram for DIODE Engine 4.10
 Wiring Diagram Cat Engine 4.11
 Wiring Diagram Cat Engine 4.12
 Wiring Diagram Cat Engine 4.13
 Wiring Harness Diagram for the Kubota Engine 4.14

SECTION FIVE: DECALS

Right Side from Operators Position 5.1
 Left Side from Operators Position 5.2
 Right Side from Operators Position 5.3
 Tow Bar 5.4
 Dash 5.5

SECTION SIX: TRANSLATIONS

Translations 6.1 to 6.6

SECTION SEVEN: INDEX

Index 7.1 to 7.3

RECORDS

Serial Number _____
 Model# _____
 Engine Type: _____
 Engine Serial Number: _____
 Accessories: _____

Safety Guidelines, Machine Operation and Service

1. Read all decals (See Decal Section) and manuals before starting and/or operating the Terramite Street Sweeper.
2. Do not make any adjustments or repairs or operate if parking brake does not work, repair the parking brake, first, before making any adjustments or other repairs to this street sweeper.
3. Parking brake must be set before engine is started and after it is stopped.
4. Protective eye wear must be worn while operating/servicing/adjusting this machine or when working within 100 feet of the Terramite Street Sweeper.
5. The Terramite Street Sweeper must not be operated if any person is within working range of the sweeper and/or is not wearing proper protective safety attire.
6. You must disengage both rear wheel lock outs before making any repairs or adjustments.
7. Repairs and or adjustments must not be made with the engine running. Otherwise, the operator must be in his seat with parking brake set, wheel lock-outs disengaged and wearing seat belt.
8. Do not start the Terramite Street Sweeper before inspecting both transmission return to neutral springs. Do not start if spring are not in place and functioning.
9. When servicing any electrical component, always disconnect the negative battery cable first.
10. Safety eye protection and attire must be worn when servicing battery.
11. Never "Jump-Start" the Terramite Street Sweeper.
12. Industrial accepted safety practices must be followed while operating/adjusting/repairing the Terramite Street Sweeper.
13. Towing vehicle must meet or exceed all Federal/State/Local laws for GVWR, lighting and hitch requirements for all places machine will be operated.
14. Do not disconnect any hydraulic hose or fitting until all hydraulic oil has cooled to ambient temperature and machine is turned off. Then move valve handle 6 times in both directions to relieve residual pressure.
15. Do not change direction of the machine quickly. Machine must come to a complete stop before changing directions.
16. Do not tow this machine unless the front tire clears the ground at least 6 inches, and the broom is properly hooked up to an adequate tow vehicle.
17. Use only Federal, State or Locally recommended Tow Bar Safety chains.
18. Machine must not be started/serviced or operated unless you have read and fully understand the manuals.

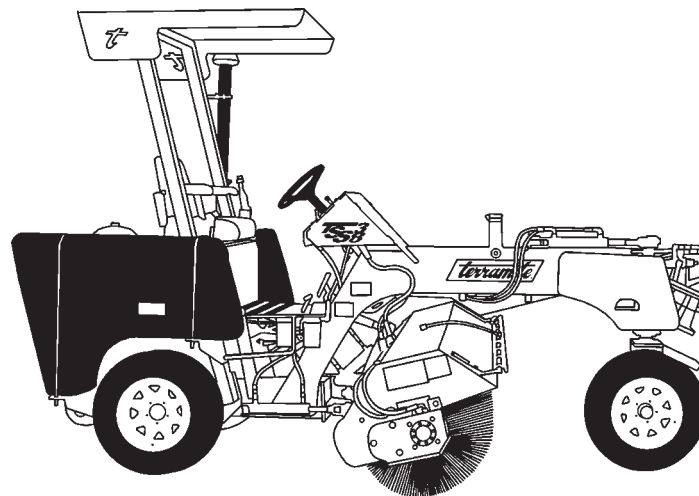

Service Operations

Safety Guidelines

Important

In this section there are very important safety rules that you must be aware of before operating any Terramite product. When you see the  symbol next to a headline, it will indicate that the paragraph contains important safety information.

For the Beginner

Regardless of whether you have purchased or rented a Terramite Street Sweeper to perform a job that you wish to complete as quickly as possible, it is mandatory that you read through the operating sections of this manual before operating the machine. The few minutes it will take will not only give

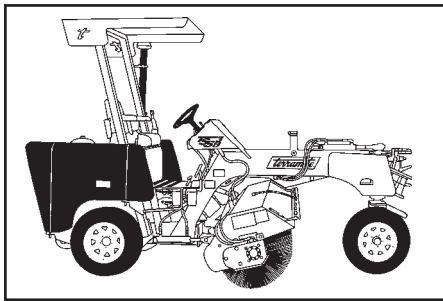

you a solid basis for learning to operate the Terramite Street Sweeper correctly, but you will have the assurance that you are operating the machine in a safe manner. We have made every effort to make the Terramite Street Sweeper the safest machine of its kind in the industry, but that is as far as we can go. The rest is up to you. Please help us by carefully reading this handbook and complying with its safety suggestions.

If You Must Use the Terramite Street Sweeper Right Now

Without question it is to your advantage and safety that you take the time to follow the operator training suggestions. Only with some guidance can you expect to become a master at the controls of a Terramite Street Sweeper in a reasonably short period. However, if this is not possible, first read the operating and safety rules section of the handbook, then at least practice for about twenty minutes. Just getting used to how the controls function will make your first attempt at working with the machine far more pleasurable, productive and, most important, safe.

Suggested Training for the Beginner

We believe you will find the training procedures an interesting and very rewarding experience. As you read through the Operator's Handbook, you will note that it is as much a safety guide as it is an instruction manual. Learning the various functions of the machine in a programmed order is the most logical approach to becoming a safe and skilled operator. It will take a little time but it will undoubtedly be the best investment in time and money you can make as a new Terramite Street Sweeper operator and/or owner. Only when the operator has mastered the controls of the machine and is in full command of its capabilities will the owner fully realize the rewards of his investment. Only after the operator has full knowledge of the safety considerations of the Terramite Street Sweeper, which are covered in this handbook, should he be allowed to operator the machine.

Do I Need an Instructor?

At this point, it is only natural that there be some concern as to whether or not you are taking on something that should require an instructor. There is bound to be some question in your mind as to whether you can possibly hurt the machine or the machine can hurt you. The answer to both questions is definitely YES, but not likely. As to the machine, we have designed the Terramite Street Sweeper to protect itself from exceeding its own limits. As to the operator, we have made every effort to design and build the Terramite Street Sweeper with your safety in mind. As to the beginner, we have no record of anyone being seriously injured while learning to use a Terramite Street Sweeper and, to the best of our knowledge, the vast majority have accomplished it pretty much on their own. However, we feel the first step is to read the Operator's Handbook. This should give you some basis for determining whether you may need personal instruction. If you feel you do, contact your local dealer or call Terramite Corporation: 1-800-428-3772.

We have your Safety in Mind.

Our experience would indicate that most beginners just climb aboard and start pushing controls. Although it says something about how easy it is to operate the Terramite Street Sweeper, it completely ignores the safety aspects of operating the machines. Even if you have someone assisting you in learning to operate the Terramite Street

Safety Guidelines (continued)

Sweeper, you will have no way of knowing to what degree they have prepared you as to the safety considerations of the machine. **READ THE HANDBOOK!** It may not cover every situation, but it covers those we believe to be most important.

An Excellent Safety Record

In our constant reference to safety, we are well aware that we are creating a false impression that the Terramite Street Sweeper is a dangerous machine to operate. Regardless, our continuous emphasis on safety is intentional, in the hope of making you a safety minded operator. The Terramite Street Sweeper has an excellent safety record, but as with a powerful automobile in the wrong hands, it can be very dangerous. Like the automobile, it is mostly a matter of knowledge, attitude and respect for your own safety and the safety of others that determines the degree of risk.

Driving the Terramite Street Sweeper

Note: Throughout this publication the word “drive” will mean to operate the Terramite Street Sweeper from one place to another. “Operate” will refer to all other functions.

Pre-Operation Inspection

Before starting the engine, check the fuel as well as the engine and hydraulic oil levels, then made a walk-around inspection to determine that everything appears normal. The most important single thing you can do to increase the life of the Terramite Street Sweeper is to properly lubricate the pivot pins. When new, the pivot pins should be lubricated every four hours the first 20 hours, and every eight hours thereafter. If you are going to haul the Terramite Street Sweeper to a job, it is usually a good idea to perform the pre-operation inspection before leaving for the job site. This should include starting the engine and testing each control of the Terramite Street Sweeper as well as driving the Terramite Street Sweeper forward and backward. Do not operate the Terramite Street Sweeper if you believe that there might be a problem. Some minor problems can become major problems if not attended to.

Hydraulic Pressure Considerations

As this may be your first experience with a machine that functions primarily through hydraulic pressure, it is imperative that you be aware of the danger of putting your

hands close to any part of the hydraulic components of the machine while the engine is running or within two minutes after being shut down. Be aware that escaping fluid under pressure can be sufficient force to penetrate the skin, causing serious personal injury. Fluid escaping from a very small hole can be almost invisible. Therefore, we recommend that you wear heavy work clothes that will fully cover your body, leather work gloves and safety eye protection when placing your hands around or near hydraulic lines or fittings while under pressure. If you suspect a leak, it can be quickly detected using a piece of cardboard or wood. If injured by escaping fluid, go to the Emergency Room of the nearest hospital. Be certain to inform them that this type of injury can cause serious infection or a reaction such as gangrene. If there is no hospital in the area, call a physician immediately.

Being Mentally Prepared

Now, before attempting to operate the machine, read through the following paragraphs involving driving the Terramite Street Sweeper and be sure you have a good mental picture of just what you are about to do and how you will do it. Please note that our only goal in this first session is for you to become familiar with the feel of driving a Terramite Street Sweeper and using its' controls.

The Hydraulic Transmission

The Terramite Street Sweeper is a very simple machine to operate but somewhat different than driving a car or truck. This is because everything on a Terramite Street Sweeper is driven by hydraulic pumps. The movements of the broom head, the power steering and even the drive wheels are the result of hydraulic pressure developed by these pumps. The pump is driven by the diesel engine. The drive wheels are powered by a hydrostatic transmission. This transmission is a fluid drive device that provides variable flow at a constant RPM from the engine to develop the range of driving speeds used in performing the Terramite Street Sweeper's tasks. Only when you wish to bring the Terramite Street Sweeper up to its maximum road speed or maximum sweeping power will you need to increase the engine RPM. For most work, all we do is set the throttle at about 3/4 power, or a little less, and leave it. The ground speed and direction of the Terramite Street Sweeper is controlled by the hydrostatic transmission and Forward/Neutral/Reverse valve.

Just a Little Does It

By lightly depressing the foot pedal we develop maximum torque, which develops power like the low gear of a manual

Service Operations

Safety Guidelines (continued)

transmission in a truck. As we depress the foot pedal further, the engine RPM remains about the same, but the Terramite Street Sweeper picks up speed over the ground. The big difference between driving the Terramite Street Sweeper and a truck is that if you want power to start up a hill, you need only depress the foot pedal about a third of the way forward, not to the floor. If you want speed, you start off with a small amount of pedal and keep increasing as the speed builds up and the required torque decreases.

No Gear Shift

When the drive pedal is in neutral position, it's like applying a brake. Anytime the engine tends to slow, let up on the pedal a little. You have to experience it to appreciate it. Although somewhat different in its control, the hydrostatic transmission is very easy to use and very forgiving. It takes only minutes to get used to, and is simpler to use than an automatic transmission in an automobile.

Some "Don'ts"

Excessive RPM can damage the engine and make the controls overly responsive. Do not change the relief valve settings. They are factory set for best machine performance. Do not go from forward to reverse or reverse to forward without pausing at neutral. It may damage the drive train.

Getting Started

Now we are ready to get aboard. Make certain that there is no oil on the steps, which might cause you to slip and fall. Your seat may be adjusted to different positions by pulling the lever located under the seat on the right. Before starting the engine, be sure to fasten your seat belt. Terramite Corporation believes that a seat belt should be worn at all times.

Some Never, Never, Nevers

Never use the Terramite Street Sweeper for a job it wasn't intended to do. Never use any other part of the machine as work platform or a personnel carrier. Never allow anyone to be under, or even close to the broom or any part of the sweeper. Never touch the hydraulic components when, or right after, the machine has been working. They reach temperatures in excess of 200 degrees and can give you a severe burn.

Slow Down, Speed Kills

Be particularly alert when backing or working in crowded areas. Always operate the Terramite Street Sweeper at a safe speed, keeping in mind your safety and that of any other people working in the area.

Not Too Much at One Time

As a beginner, this practice will require your total concentration. Therefore, while learning to use the street sweeper, we recommend that you do not put in over half an hour of practice without a half-hour break. Confusion and panic can be brought on from mental exhaustion, which can occur very rapidly until the use of the controls becomes a somewhat automatic reaction. Long sessions, requiring extreme concentration, can be potentially dangerous.

Working on a Slope (Use Extreme Caution)

Now we will cover one of the most important considerations in operating the Terramite Street Sweeper. Naturally, you will be working on some degree of ground slope much of the time unless you live in very flat country. We feel it is extremely important that we impress upon you just how treacherous a slope can be when using this machine, particularly under certain conditions. If you operate on a hillside that is slippery and/or steep enough that there is any question that the Terramite Street Sweeper will not be able to maintain braking action, you will be taking your life in your own hands. Unless you are absolutely sure that you can accomplish the work without risk, do not attempt it. A slick surface, such as dry leaves on even a slight grade, may cause your rear tires to slide out of control without any braking action whatsoever.

Emergency Procedures

Before working a hazardous area such as a hillside, take time to consider every possible problem you might encounter. Be sure you are mentally prepared for any situation and know exactly what you might do in an emergency. Remember, panic is your worst enemy, and panic usually comes when you are caught completely off guard and unprepared. Safety conscious operators run through emergency procedures before operating under any conditions that give them concern.

When Operating the Street Sweeper

First Aid and Fire. Keep a fire extinguisher and a first aid kit nearby and know how to use them.

Loose Clothing. Never take chances by wearing loose clothing, watches or rings. Keep clothing and hands away from moving parts.

Only Room for One. When in operation, only the operator should be permitted on the machine.

Mounting the Machine. Always mount your machine from the side. Put one foot on the machine at a time. Never mount from the rear or while the engine is running. Before you start the engine, always fasten the seat belt. When in operation, do not jump either on or off the machine. Never mount or dismount a moving machine.

Starting the Terramite Street Sweeper. Do not attempt to start or operate the Terramite Street Sweeper except from the operator's station. Never operate the controls from the ground, as this could result in serious injury or even death.

Prevent Accidental Starting. Disconnect the negative wire from the battery. Put a Lock Out Tag on the machine while being serviced. Remove key.

Other Battery Considerations. Do not use the battery charger as a booster to start the engine. Never disconnect

the battery when the engine is running. Never attempt to charge a frozen battery. An explosion may occur.

Operating at Excessive Speed. Operating unit at excessive speeds increases the danger of personal injury. Do not change the governor setting or tamper with components which may increase speed.

Excessive Hydraulic Pressure. Do not raise the hydraulic pressure beyond 2200 PSI. Components may become overloaded and break, causing serious injury. This also shortens the life of your machine.

Excessive Tire Pressure. Never exceed maximum recommended tire pressure, as serious injury or even death may result.

Relief Valve Settings. Do not change the relief valve settings. They are factory set for the best machine performance and safety. If it becomes necessary to adjust this setting, refer to the Terramite Street Sweeper Service Manual for the proper procedure.

Parking Machine. Always park your machine on level ground with parking brake engaged.

Prevent Fire. Be cautious of fire when operating in dry, dead grass or brush.

Hazards and Hazardous Areas

Approved Container. Always use an approved container when handling and storing diesel fuel or solvents.

When Loading Fuel. Never fill the fuel tank while smoking, when near an open flame or with the engine running. Leave room for fuel expansion, 1-1/2 to 2 inches. Replace fuel cap securely.

Cleaning Parts. Never use gasoline or diesel fuel for cleaning parts. Always use a nonflammable solvent.

Overhead Wires. Watch for overhead wires and cables. Never touch the wires with any part of the machine. If you contact an electric line, stay on your machine until help arrives, if you are not being shocked. If you have to jump from the machine, make sure you are not touching the machine as you hit the ground.

Two Men, if Possible. When working in hazardous areas, be extremely alert. If possible, two men should work together, one operating the machine and the other directing

him and watching for dangers. Develop a hand signal system or use hand signals shown on page 1.4.

Unventilated Area. Never operate the Terramite Street Sweeper in an unventilated area. Carbon monoxide and methane gas are colorless and odorless.

Explosion. Sparks can come out of the muffler or the electrical system. Do not operate the machine in areas where there are flammable vapors or dusts that are of the nature that would cause an explosion.

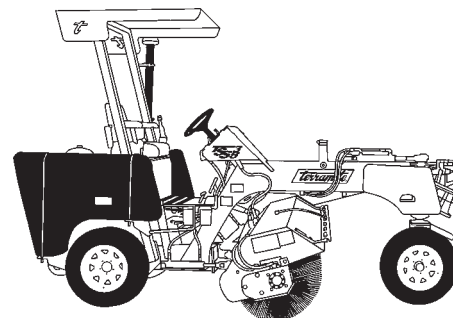

Service Operations

Transporting the Street Sweeper with a Trailer



General Considerations

Proper Towing Equipment. It is important that you use a truck that is capable of towing the trailer and the Terramite Street Sweeper, and that it is equipped with the proper tie-down equipment for securing it to the trailer. When on a road or highway, at night or during the day, use accessory lights and an SMV (Slow Moving Vehicle) sign for adequate warning to other drivers. In this regard, check state and local regulations.



Do Not Wrap Chains Around Cylinder Rods.

This may scar or bend them.



MAXIMUM TOWING SPEED WITH A TRAILER IS 60 MPH



Trailer Size and Type

The trailer you select should have a load carrying capacity of at least 7000 pounds with a tandem axle, and at least 14 feet long. You will need to check with State authorities as to whether electric or hydraulic surge brakes are permitted.



Loading Can Be Tricky

After setting the truck's emergency brake and blocking the wheels of the truck and the trailer, drive the machine slowly onto the trailer. Keep in mind that the weight of the Terramite Street Sweeper going onto the trailer may raise the rear of the truck off the ground, causing the truck, trailer and Terramite Street Sweeper to roll forward. Driving onto a tilt bed trailer can also be very tricky as the trailer bed will likely slam down, tending to make you overcompensate by going backwards, thus causing the trailer to seesaw back and forth.



Securing the Terramite Street Sweeper to a Trailer

Once the Terramite Street Sweeper is positioned on the trailer, block each side of the front and rear tires. Using chains, bind it to the trailer. There are binding rings welded onto the frame under the engine and on the front. Always put the binders toward the front and the rear, never straight out. The machine may shift if the binders are placed at 90 degree angles. Measure the height of the machine on the trailer so you will know the minimum height under which you can pass.



CAUTION!

Always place the load binder handles on the right so you can tighten them down without exposing yourself to oncoming traffic. It is good practice to use a piece of tie wire to keep the handle from flying up. Be careful if you use a cheater bar to lock binders down. Fingers have been broken when the binder flings over center. A ratchet binder is the best, followed by over center binders. Come alongs are not very safe due to their poor construction. Make sure all loose items are secured. Be sure to check tightness after you start, and periodically as you travel, as the load may shift.



Towing Considerations for the Terramite Street Sweeper

At highway speeds, if there is too much weight on the back of the trailer, it may suddenly and without notice start whipping violently back and forth. This can be very dangerous and is caused by not having enough weight on the tongue. It can be corrected by properly positioning the Terramite Street Sweeper on the trailer. Too far forward may produce more weight than the hitch or even the truck can handle; whereas, too far back can be dangerous, as described above. It is a good idea to go to a weigh station, and after determining the best position, mark where to park the wheels. You must also be careful as to just where you place any additional cargo you may take along. Most trailer manufacturers recommend that 10% of the weight be on the tongue.



CAUTION!

Test the braking capabilities of the truck and trailer combination on the first clear stretch of road. Most brake controllers can engage the trailer brakes independently of the towing vehicle's brakes. This feature can be used to help straighten out a skid.



Safe Towing Practices

SAFETY FIRST! Always maintain extra distance from the vehicles in front of you and allow extra room when turning corners. Make lane changes slowly to keep the load from shifting, and let other drivers, who may be in your blind spot, get out of your way. Periodically check your trailer and safety equipment. Remember, you are towing the equivalent of a small pickup truck behind you.

Towing the Street Sweeper



General Considerations

Proper Towing Equipment. It is important that you use a truck that is capable of towing the sweeper. When on a road or highway, at night or during the day, use accessory lights and an SMV (Slow Moving Vehicle) sign for adequate warning to other drivers. In this regard, check state and local regulations.



Do Not Wrap Chains Around Cylinder Rods. This may scar or bend them.



MAXIMUM TOWING SPEED IS 60 MPH



Attaching Sweeper To Towing Truck

1. Park truck on level ground, turn off engine, and set parking brake.
2. Drive sweeper near truck. Turn off sweeper engine, set sweeper parking brake (See Figures 1 & 2).
3. Remove tow bar upper locking pin (See Figure 3) and place tow bar in line with sweeper (See Figure 4). Re-attach tow bar upper locking pin, making sure its secure



WARNING!

To prevent injury have someone assist in the removal of the tow bar upper locking pin and lowering of the tow bar.

4. Remove the tow bar lower locking pin (See Figure 4).
5. Start sweeper engine. Helper uses tow bar lift valve (See Figure 5) to raise tow bar to towing truck height.
6. Connect tow bar to towing truck and secure.
7. Use tow bar lift valve to raise front of sweeper until the tow bar lower locking pin can be replaced and secured.
8. Attach safety chains and light cord to towing truck.
9. Place broom assembly in up position and secure with its chain.
10. Turn off engine, release parking brake, and disconnect lock out hubs (See Figures 6 & 7).
11. Drain water tanks (See Figure 8).
12. To prepare broom for service after towing, reverse order of these instructions.



CAUTION!

Test the braking capabilities of the truck with sweeper prior to driving on the road.



Safe Towing Practices

SAFETY FIRST! Always maintain extra distance from the vehicles in front of you and allow extra room when turning corners. Make lane changes slowly, and let other drivers, who may be in your blind spot, get out of your way. Periodically check your sweeper and safety equipment. Remember, you are towing the equivalent of a small pickup truck behind you.

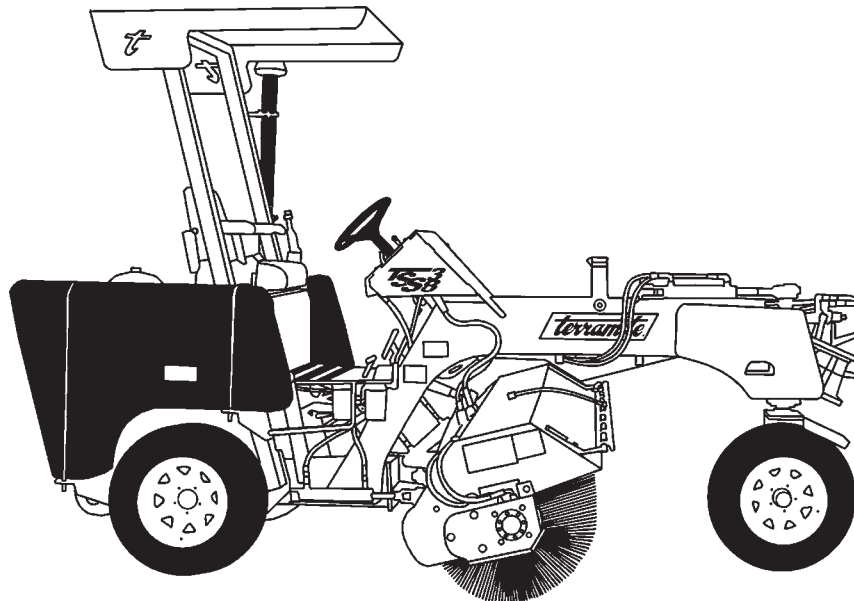

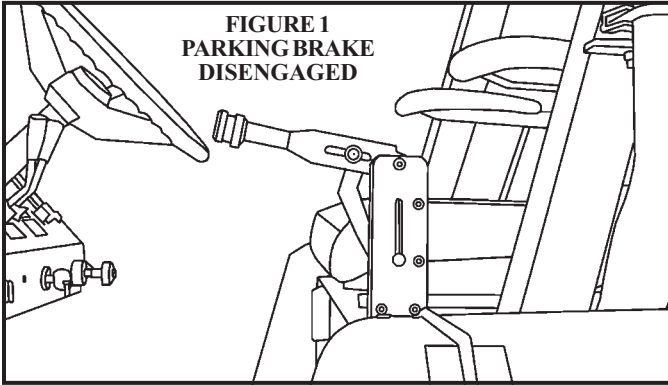

FIGURE 1
PARKING BRAKE
DISENGAGED

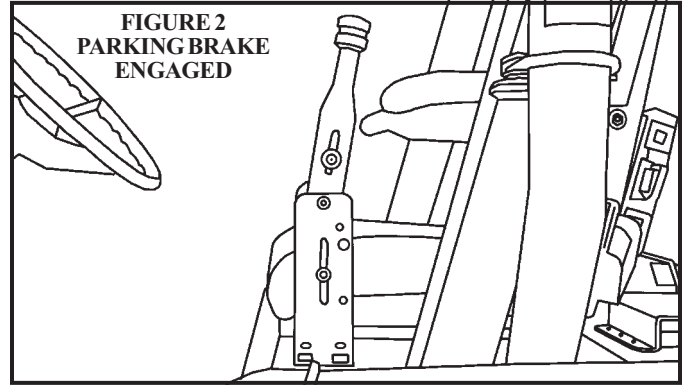

FIGURE 2
PARKING BRAKE
ENGAGED

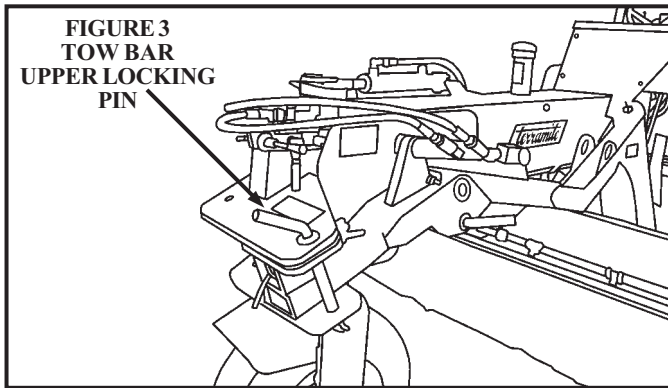

FIGURE 3
TOW BAR
UPPER LOCKING
PIN

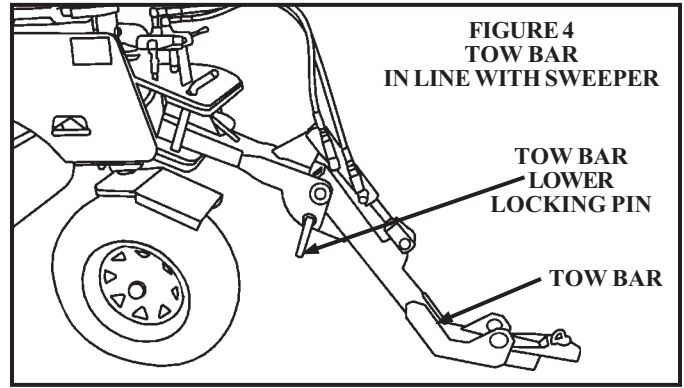

FIGURE 4
TOW BAR
IN LINE WITH SWEEPER

TOW BAR
LOWER
LOCKING PIN

TOW BAR

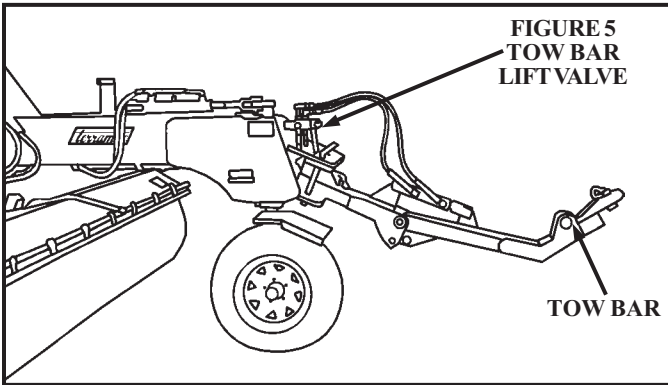

FIGURE 5
TOW BAR
LIFT VALVE

TOW BAR

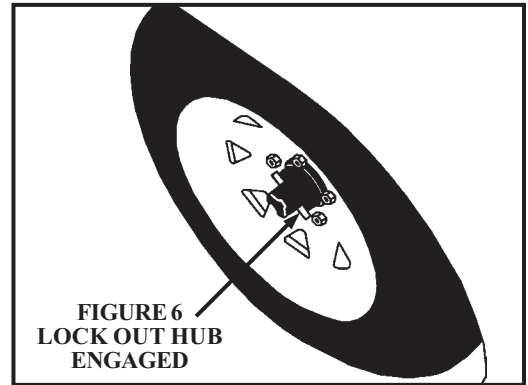

FIGURE 6
LOCK OUT HUB
ENGAGED

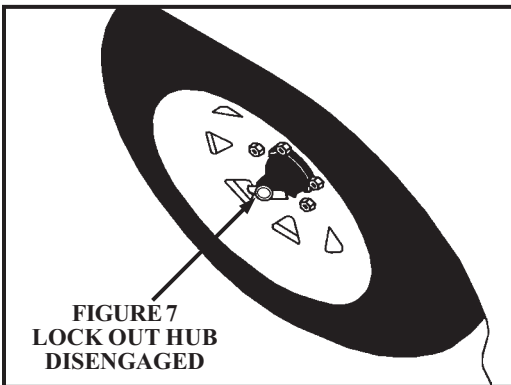

FIGURE 7
LOCK OUT HUB
DISENGAGED

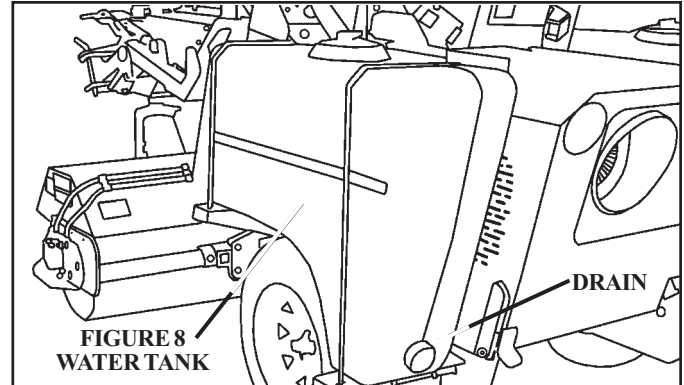

FIGURE 8
WATER TANK

DRAIN

Storing the Street Sweeper

For Storage of More than 30 Days

To insure maximum performance and minimum deterioration, the following procedures should be performed when the Terramite Street Sweeper will be idle for more than 30 days:

1. Wash the Terramite Street Sweeper and let dry (waxing will help prevent paint oxidation).
2. Change engine oil.
3. Charge battery fully and disconnect the battery leads.
4. Fill fuel tank within 2 inches of filler neck (keeps out condensation) and add fuel conditioner.
5. Squirt a small amount of oil into cylinders and crank the engine over a few times.
6. Grease all pivot pins. Liberally apply cup grease to all bare metal surfaces such as buckets and exposed cylinder rods. Grease all pivot pins. Retract all cylinder rods. Use WD40 on all electrical parts and areas inaccessible to regular grease.
7. Set the Terramite Street Sweeper on stands so the tires are off the ground. (Keeps tires from developing flat spots.)
8. Deflate tires to 1/2 pressure to relax cords.
9. Use a protective such as Armor All® on hoses, seat and tires to keep them from weathering
10. If the Terramite Street Sweeper is to be stored outside, cover with a tarp or plastic cover to minimize weathering.

Engine Operating Instructions

NOTE: With your Terramite Street Sweeper you will receive an Operation and Service Folder for the particular engine supplied with your machine. This manual contains detailed information as to operation, maintenance and repair of the engine and its various components. However, before attempting any major repair of the engine, contact your dealer or the factory as to whether it will affect your factory warranty.



Before starting make sure that nobody is standing in the immediate vicinity of the engine or driven machine.

1. ENGAGE PARKING BRAKE
2. CHECK THAT MACHINE IS IN NEUTRAL
3. CHECK THAT BROOM ROTATION IS IN OFF POSITION



Engine Fuel

WARNING! Diesel fuel, although less explosive than gasoline, is highly flammable, and its vapors can explode under certain conditions. Store diesel fuel only in approved containers in unoccupied buildings and away from sparks or flames. Do not add diesel fuel while the engine is hot or running, or start the engine near spilled fuel.



WARNING!

Do not activate the starter for more than 20 seconds. If the engine does not catch, wait one minute then try again.



WARNING!

If engine does not start after 2 attempts, refer to operation manual supplied with the machine or call Terramite Service Technicians for assistance.

Starting Kubota and Deutz Engines

1. Place key in ignition
2. Turn key clock wise to start position.
4. Release Key as soon as engine fires.



WARNING!

Do not activate the starter for more than 20 seconds. If the engine does not catch wait one minute then try again.



WARNING!

If engine does not start after 2 attempts, refer to operation manual supplied with the machine or call Terramite Service Technicians for assistance

Service Operations

Engine Operating Instructions (continued)

Do Not Use Ether as a Starting Aid

The engine has a high compression ratio, and using ether will ruin your engine. **The damage will not be covered under your warranty.**

Total Failure of Starter

If the starter does not turn the engine over, shut off the starter immediately. Do not make further attempts to start the engine until the condition is corrected.



CAUTION!

Do not crank the engine continuously for more than 20 seconds at a time. If the engine does not start, allow a two minute cool-down period between starting attempts. Failure to follow these guidelines will burn out the starter motor.



CAUTION!

If the engine develops sufficient speed to disengage the starter but does not keep running (a “false start”), the engine rotation must be allowed to come to a complete stop before attempting to restart the engine, or engine damage may result.



WARNING!

Do not tamper with the governor setting to increase the maximum engine speed. Over-speeding is hazardous and will void the warranty.



WARNING! Do not use JP4 Fuel or Ether

The minimum centane number 45 (Aviation fuel) JP4 or ether starting fluids must not be used.

Weather Considerations

Diesel Operation in Hot Weather

Operating the diesel engine in hot weather is mostly a matter of keeping the coolant at the correct level, the radiator clean and keeping an eye on the fan belt. Also, be certain of the viscosity of lubricants.

Temperatures Below 32 Degrees

There are several precautions which must be followed when the temperature drops below 32 degrees Fahrenheit. The oil in the engine and the hydraulic system needs to be changed to winter weight and a new oil and air filter should be considered. The battery should be kept at full charge. As starting may be more difficult, be sure that you do not run starter more than 20 seconds, followed by a two minute cooling off period. Do not hit the outside of the casing of the starter, as you may break the ceramic magnets.

Fuel Conditioner For Diesel Engines

Diesel fuel gets waxy at low temperatures and may not flow through the filter and pump at the normal rate of flow. Therefore, a good fuel conditioner additive is highly recommended for temperatures below 32 degrees Fahrenheit.

Below 10 Degrees

Special procedures must be followed so your machine may be readily started without damage. The hydraulic system and the engine need to be fitted with electric heaters. The machine can be warmed with a high output forced air heater.

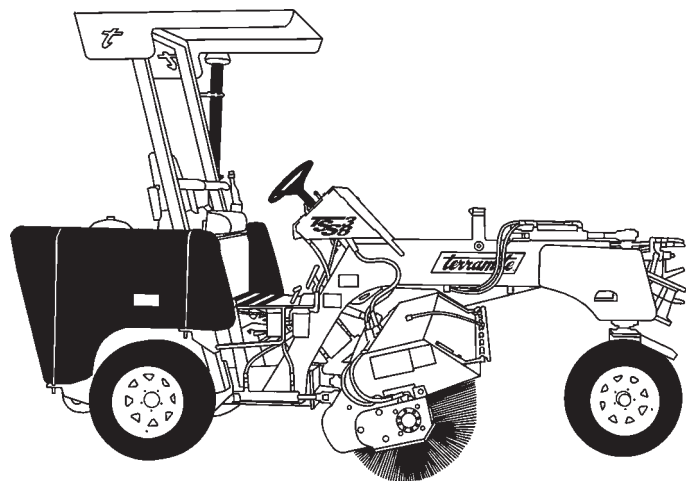

Periodic Service

General Considerations

These required maintenance procedures should be performed at the frequency stated in the table. They should also be included as part of any seasonal tune-up. Perform these maintenance procedures more frequently when the engine is operated under extremely dusty or dirty conditions. Although your Terramite Street Sweeper is made of the finest and most durable materials, it will only hold up if given proper care. The maintenance procedures are very simple and easy to do. We have also included space in the back of this handbook for keeping a service record of your machine.

IMPORTANT: See attached *New Machine First Service Schedule* for items that should be checked or serviced during the first 4 to 50 hours.

| REQUIRED MAINTENANCE | FREQUENCY |
|--|------------------------|
| Clean Air Intake Screen | Daily |
| Check Engine Oil Level | Daily |
| Check Hydraulic Oil Level | Daily |
| Check/Replace Fuel Filter** | As Required |
| Change Oil and Filter | As Specified |
| Clean Cooling Fins and External Surfaces | 50 hrs. or as required |

****SEE ENGINE MAINTENANCE MANUAL**

We also suggest that the air filter be checked weekly in the event you are working in extremely dirty or dusty conditions. The manufacturer's air filter should be used, or warranty may be denied. Otherwise, check and clean monthly.

Engine Oil Service

Engine Oil (Recommended)

Refer to engine operating manual supplied with machine.

Checking Engine Oil

Before checking the oil, make sure the engine is stopped and resting on a level surface. Also, make sure the engine is cool and the oil has had time to drain into the sump. Bring the level up to, but not over, the full mark on the dip stick. Always check the level before adding more oil.

CAUTION: Do not operate the engine above or below marked area on the dip stick.

Changing Engine Oil

For a new engine, change oil after the first 5 hours of operation, after that every 100 hours (50 if multi-viscosity oil is used). Drain oil while the engine is warm from operation. The oil will flow freely and carry away more impurities. Drain oil as follows: Remove the oil drain plug and oil fill cap. Dispose of the oil in a manner that meets Local, State and Federal regulations. Reinstall the drain plug. Make sure it is tightened securely. Be sure the engine is level when filling and checking oil. Then fill with new oil to the top line on the dipstick. Refer to engine operating manual for proper type. Always check the level on the dipstick before adding more oil. Reinstalled the oil fill cap and make sure it is tightened securely.

Changing the Engine Oil Filter

Your Diesel is equipped with an oil filter. Replace the oil filter, in accordance with the "Oil Change Intervals" table. Always use a genuine OEM oil filter and replace as follows: Drain crankcase oil, then remove old filter. Before installing replacement filter, apply a thin coating of clean oil on the surface of the rubber seal. Turn filter clockwise until rubber seal contacts the filter adapter, then tighten filter an additional 2/3 to 3/4 turn. Add an additional 1/2 pint of oil for the filter capacity. Start the engine and check for oil leakage.

Extended Engine Oil Change Intervals

NOTICE: Using other than the proper class oil or extending oil change intervals longer than recommended will cause engine damage which is **not covered by the engine warranty.**

Engine Air Filter (Paper Element)

The diesel engines are equipped with a high-density paper air cleaner element. The paper element should be replaced every 100 hours. Do not wash or use pressurized air to clean the paper element. Before installing new filter, be sure to inspect it for damage and that it fits perfectly when replaced.

Service Operations

Hydraulic System Service

Check Hydraulic Oil Level Daily

Before checking the hydraulic oil sight gauge, all cylinders should be retracted. The correct oil level is halfway up the sight gauge. To avoid damage to the hydraulic pumps, drain and replace milky-looking oil. Proceed as follows to drain the oil out of the reservoir tank.

Hydraulic Oil Filter

When the machine is new, the system oil and filter should be changed within the first 50 hours. After that, every 200 hours. Fill system with API SF/CD 10W below 40 degrees. Oil should be changed on a level surface. It is recommended that the oil be changed right after use while the oil is warm.

Hydraulic Oil Leaks Can Be Dangerous

WARNING! As this may be your first experience with a machine that functions primarily through hydraulic pressure, never inspect or put your hands close to any part of the hydraulic components of the machine while the engine is running or within two minutes after being shut down. If injured by escaping fluid, go to the emergency room of the nearest hospital at once and tell them the nature of the injury. If there is not a hospital in the vicinity, call a physician. Serious infection or a reaction such as gangrene can develop if proper medical treatment is not administered immediately.

Minor Hydraulic Oil Leaks

Oil leaks are often difficult to locate, as oil may leak from areas in the machine that are hidden from view. However, if you can locate the leak, take a cloth and completely dry everything around the leak to determine how fast the oil is escaping. A drop of oil every 10 seconds is only 1/2 oz. per hour. Do not use teflon tape to try to stop a leak, as it can get loose in the system. You can easily over tighten a fitting or hose wrapped with teflon, causing a housing to crack. The preferred sealant is Loktite™ hydraulic thread sealant with teflon paste.

DANGER! Oil and Fittings Get Hot

It is normal for the hydraulic oil to reach 170 degrees; and the hydraulic hoses, cylinders and components, acting as a large passive radiator, can reach temperatures of over 200

degrees. However, if the surface or hydraulic oil temperatures exceed these temperatures, it may be caused by having a control valve held open too long. Always return control valve to neutral when not in use. It could also indicate a low oil supply or contaminated oil. If low, refill. If contaminated, drain and refill with new oil, and replace filter. It could also indicate a kink or dent in a hose line or a worn pump. (See Service Manual for Pump replacement.)

NOTE: Always make sure major leaks are contained and the oil disposed of in a proper manner. Stains on concrete may be removed by applying a mixture of oil dry and solvent. Let mixture set for a few hours before removal. Dispose of according to applicable Local/State/Federal Laws.

Changing the Hydraulic System Oil

1. Make sure all the cylinder rods are fully retracted.
2. Remove the sump line.
3. Remove the sump strainer, wash it in solvent, dry thoroughly.
4. Replace in reverse order.
5. Fill the system with recommended oil until it reaches the proper level.

NOTE: There is no need to bleed the hydraulic system, the air will come out of the oil by itself. The machine may vibrate for a few minutes until the air purges. Be sure to dispose of your waste oil in a manner acceptable to Federal, State and local authorities.

Some Tips on Hydraulic Hoses

Inspect hoses regularly for nicks, cuts and wear. There are two wire braid layers under the rubber outer cover. When wire is exposed but undamaged, the hose still may be used, but should be replaced as soon as possible.

If You Need New Hydraulic Hoses or Parts

All hoses are JIC. Hoses may be obtained from Terramite Corporation or any industrial rubber supplier or hydraulic shop. Return the old hoses so they can match them. Short hoses may be made from the good portion of a damaged hose.

Street Sweeper Lubrication

Lubricating the Pivot Pins

The most important single thing you can do to increase the life of the Terramite Street Sweeper is proper lubrication of the pivot pins. The pivot pins should be lubricated with a good lithium based grease every **four hours** of operation. Wipe dirt from the fittings before greasing. Replace any lost or damaged fittings immediately.

How to Ruin a Good Machine

The first 20 hours of use are critical to the life of the machine. The pivot pins have minute edges which need to be broken in just as an automobile engines need to be broken in. If the pins are not adequately greased, they will break their retainers and work out, possibly causing damage

to your machine. An ungreased pin will rust. The next time you use the machine the rust wears off, exposing more metal, which also rusts. The rust and dirt make a destructive grinding compound. Many people falsely blame the manufacturer for their own neglect in lubricating the machine. This is not covered under your warranty.



Use Caution when Replacing Pins

When driving pivot pins in or out, use care to guard against injury from particles that may chip off the pin or object used in striking the pin. These pins can fly out at considerable speed if they are not tapped lightly just before they come out. Safety glasses must be worn.

Battery and Tires

Low Maintenance Battery

Your Terramite Street Sweeper is equipped with a low maintenance battery. It uses a special construction to minimize water requirements. There is an “eye” on the battery to determine the conditions.

Cold Weather Considerations

NOTE: Cold weather makes a marginal battery useless. A battery fully charged at 80 deg. F. will have only 60% of its capacity at 32 deg. F., and only 40% at zero. A half-charged battery has only 32% at 32 deg. F and 21% at zero.

Tire Pressures and Rim Size

Titan - ST Radial 205/75R14
50PSI Cold -Load 1760 Lbs.



Avoid High Tire Pressure

CAUTION! Excessive tire pressures increase the possibility of punctures and cause a rougher ride. The rim or tire could blow out, causing extreme injury or even death!

Tire Traction and Hazards

Avoid excessive wheel spin when loading. On most surfaces, wheel spin causes loss of traction and premature wear out of tires. Watch for hazards such as nails, glass, etc.

Paint and Cleaning

Protecting the Paint

Because it is highly resistant to nearly everything, it requires little care. But constant exposure to sunlight will fade it just as other paints eventually fade. A coat of wax will help protect it. Leaving spilled diesel on your hood is not only an unsafe practice, but will cause stains and will

inevitably eat through your paint. Small scratches should be touched up or kept waxed to keep rust from attaching the metal under the paint.

Service Operations

Paint and Cleaning (continued)

Paint Cleaning Solutions

Some cleaning solutions and solvents used in high pressure washers may bleach the finish if used in high concentration or not rinsed from the machine. This can be avoided by diluting the cleaning solution or not letting it set too long.

Fasteners (Nuts and Bolts)

It is particularly important to check all nuts and bolts for tightness after the first 5 hours of use. All drive train bolts should receive extra attention. Thereafter, check every 250 hours.

Trouble Shooting

If a particular difficulty is experienced, check the symptoms listed below. Possible causes and remedies are given for each symptom. If the trouble is not corrected after following the suggested solution, call your dealer or call Terramite Corporation.

Total Failure of Hydraulic Power

(Engine is running, but nothing works)

Stripped engine to transmission coupling. Must be replaced.

Loss of Tram Power

The hubs may be disengaged for towing. This will cause loss of tram power.

This may indicate a worn transmission. Check with factory technician

Loss of Sweeping Power

Check for:

1. Low hydraulic oil.
2. Collapsed hose (hose can collapse internally, not showing any visible signs.)
3. Worn Pump. Check pump pressure.
4. Internal Valve leakage. Valves will sometimes develop leaks between the spools, yet not leak outside. Switching hoses to another valve will determine whether the valve section is bad.
5. Broken or weak relief valve. Check pressure. Check for fatigued or broken relief valve spring. All cylinders will lack power. You will have a little more power when your machine is cold. A weakened spring will lose power so gradually that you may not notice the decline in power until it seriously affects the machine performance. A broken spring will cause a sudden drop in cylinder power.

Sluggish and Slow Operation

Oil still cold. Pump badly worn or damaged. Restriction in suction line. Clogged oil filter or sump strainer.

Control Valve Sticks or Works Hard

Normally, this is a problem for your dealer's service department. It is usually dirty valves, tie bolts too tight or float detent position adjusted too tight.

Street Sweeper Doesn't Move in Either Direction

If this happened over a period of time, the transmission is totally worn out. If it happened instantly, check for the following:

1. Make sure rear lock-outs are in.
2. Foot pedal disconnected.
3. Bolts broken on coupling.

Transmission/Pump Makes Noise

First check the oil viscosity. If too high, replace with specified oil. Then look for a kink or dent in oil lines. If not of these, it may be air in the system. See your dealer.

Erratic Motion

1. Retract all rods and check hydraulic oil level.
2. Broken or weak pedal spring.
3. Worn transmission.

Hydraulic Oil Foams

1. Low oil supply.
2. Air leak in line from reservoir to pump.
3. Incorrect hydraulic oil.
4. Blocked valve restrictor.
5. Check sump hose for tightness.

Trouble Shooting (continued)

Hydraulic Oil Heats

1. Low oil supply.
2. Contaminated oil.
3. Control valve held open too long.

None of the Problems Listed

If the problem involves a part of the machine, such as the engine, transmission, hydraulic pump, etc., that is manufactured by someone other than Terramite Corporation, first check your service manual for more detailed information. If you do not find it there, contact your dealer or the original manufacturer's service department. For dealer locations, call Terramite Corporation at 1-800-428-3772 or International 1-304-776-4231.

Wheel Drive Slow or Will Not Go

1. Drive motor seal failure may be checked by removing the plug on the rear wheel lock out. If there is any oil present the motor shaft seal has failed.
2. Check hydraulic pressure of transmission.

Broom Rotation Stops or is Slow

1. Check Gear pump pressure using a portable hydraulic test box, test the GPM and PSI with the engine RPM

at full throttle, the Gear Pump should produce from 9-1/2 to 10-1/2 GPM at 3,000 PSI.

2. To check broom motors individually, disconnect the 2 hoses to the motor and plug the hoses with steel caps. Install a jumper hose between the ports to eliminate leakage.
3. If the broom motor is not able to run the broom, remove the broom motor and make sure the square key on the broom motor shaft has not sheared.

Setting the Auxiliary Hydraulic System Main Relief Valve

1. Install a 5,000 lb. pressure oil filled gauge in the outlet port of the relief valve.
2. Start the engine and set the throttle at full. Slowly turn the adjustment screw in (turn clockwise) until a consistent pressure of 3,000 PSI is reached. Lock down the lock nut and install the acorn cap on the screw and recheck the pressure.

Main Pump Output Testing

Use a hydraulic pressure gauge and a flow meter that measures both flow (GPM) and pressure (PSI). The transmission pump will produce 15 GPM and approximately 3,500 PSI with the engine set at full throttle.

Machine Operation Control Location

Purpose and Scope

| ITEM | LOCATION | FUNCTION |
|----------------------------|---|--|
| 1. Seat Belt | Left and right side of seat. | To prevent operator from falling off machine. |
| 2. Parking/Emergency Brake | Lever to left of seat. | To hold machine from rolling when parked and in neutral. To be used for emergency stopping of machine. |
| 3. Variable Speed | Forward and to the right of the right foot position on the floorboard | Varies machine speed in forward and reverse when F/R Valve handle is actuated. |
| 4. F/R Valve Lever | Located to the right of the operator seat. | A. Forward position allows machine to travel forward when variable speed pedal is depressed (See Item 4). B. Center position hydrostatically locks machine in park (be sure to also set Parking Brake). |

Service Operations

Machine Operation Control Location (continued)

| ITEM | LOCATION | FUNCTION |
|------------------------|--|---|
| | | C. Rear position allows unit to travel in reverse when the variable speed pedal is depressed (See Item 4). |
| 5. Keyswitch | Centrally located below the steering wheel. | Preheats engine glow plugs when turned and held in full left position, starts engine when turned and held in full right position. 1st "Notch" positions from full right is "Run", and 2nd "Notch" position from full right is "Off". (On Kubota ONLY) |
| 6. Broom Rotary | Located to the right of the steering wheel. | When pushed forward broom sweeps forward, when in center position, broom stops. Variable speed rotation. |
| 7. Broom Left-To-Right | Located to left of and furthest from the steering wheel. | When pushed forward, right end of broom moves towards rear when pulled back, right end of broom moves forward. |
| 8. Broom Lift Control | Located to left of and closest to the steering wheel. | When pushed all the way forward and locked into detented position, broom head goes to lowered and operating float position. When lever is pushed forward broom head raises off of surface. |
| 9. Engine Throttle | To right of and below the steering wheel. | To set engine operating speed. |

Lubrication and Maintenance Chart

| ITEM | DESCRIPTION/LOCATION | MAINTENANCE SCHEDULE |
|------------------------------|--|---|
| 1. Grease Fittings | <ul style="list-style-type: none"> a. (2) Bearing on Front Fork b. (1) Variable-Speed-Pedal under floorboard c. (2) Left and Right on Brake Rod d. (1) Foot Brake | Grease all fittings daily |
| 2. Hydraulic Oil | With oil hot, oil level should be in center of eye on side of hydraulic tank and/or 1" below top of tank. Capacity: 20 Gallons | Change Hydraulic Oil every 6 months or as needed. |
| 3. Hydraulic Spin-On Filters | <ul style="list-style-type: none"> a. 10 Micron Part #21002 2 under floorboard. b. Hydraulic Tank Screen Part #38072 at rear of Hydraulic Tank. c. High Pressure Filter Element Part #38019 inside hood and to right of engine. | Change both Spin-On filters every 3 months. Remove and clean every 6 months. Change every 6 months. |

Lubrication and Maintenance Chart (continued)

| ITEM | DESCRIPTION/LOCATION | MAINTENANCE SCHEDULE |
|-------------------------------|---|--|
| 4. Engine Oil | Engine Oil Type: Refer to Engine Manufacturers Operations Manual. | Change Engine oil and all filters, air, spin-on fuel, in-line fuel, and oil every 150 hours. |
| 5. Radiator Water/Anti-freeze | Strictly 50% water and 50% permanent Antifreeze mixture only!!!! | Check mix and level. Level to be 1/2 full in plastic over-fill tank. |
| 6. Tire Pressure | 45 PSI to 50 PSI | Check Daily. |
| 7. Water Filters | Under Floorboard, Water Tanks | Clean as Needed |
| 8. Front Wheel Bearings | Front Wheel inside and outside. | Repack monthly. |
| 9. Fuel Tank Drain | Pipe plug located in center of and at bottom of fuel tank. | Drain once a year. |
| 10. Wheel Lock-Out Oil Level | Between wheel and frame. Remove female hex plug on front or back of housing to check. Capacity: 6 Ounces Motor Oil: SW 30 Wt. Detergent | Check every 3 months. |

Service and Maintenance Points

All references to "Left" or "Right" side of the Terramite Street Sweeper are stated as from the Operators seat facing forward.

Anti-Freeze Mix

Liquid cooled engines are very sensitive to the water/antifreeze mix. Too much of either water or antifreeze will cause engine overheating. The proper mix is 50% water and 50% antifreeze.

Air cooled engines have no need for anti-freeze.

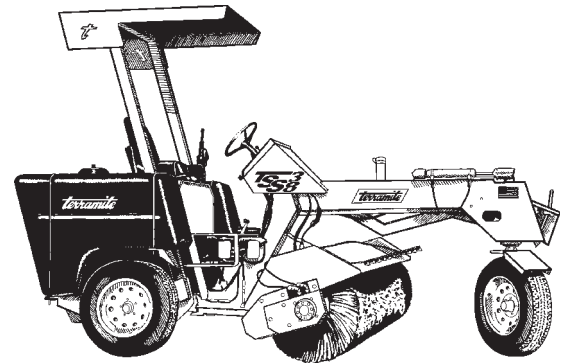

Machine Trouble Shooting & Hydraulic Component Check-Out

Before testing any hydraulic component always check the hydraulic oil level. Bring the hydraulic oil temperature up to 20° over Ambient. Place the machine on a flat surface.

The hydraulic oil level should be in center of the "Eye" indicator and/or not more than 1" below the top surface of hydraulic oil tank.

Service Operations

Proper Care and Use of Broom Wafers

Broom Storage

The broom portion of the Terramite Street Sweeper should be stored away from direct sunlight. Prolonged exposure to sunlight greatly reduces the life of the bristles.

Do not leave broom head lowered with weight on the bristles when not in use. Weight on the bristles for long periods of time will cause the bristles to become permanently deformed, resulting in lowered sweeping effectiveness.

1/2 Poly - 1/2 Wire Wafers (Standard)



1/2 Poly and 1/2 Wire Wafers are used for varying sweeping conditions. The 1/2 and 1/2 combination is used to sweep throughout the year without changing cores. This combination is the most used approach. Eight foot brooms require 24 poly and 23 wire wafers and six foot brooms require 19 poly and 18 wire wafers

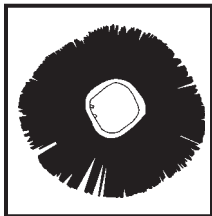

Poly Wafers

For normal sweeping operations, such as sand, dirt, paper, etc. This wafer will be the best for dry sweeping. Maximum 3" brush pattern.

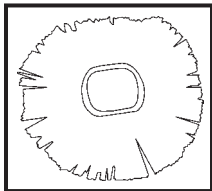

Wire Wafers

For hard material sweeping, such as concrete curing, mud, rock, snow, etc. This wafer is the strongest wafer available and with the sharpest cutting force. For snow usage the ends pierce

the snow and ice quicker than poly wafers. This quickness requires less down pressure.

Maximum 3" brush pattern. Exceeding this pattern will lead to wire breakage, excessive wire wear, and short life of the wafers.

Brush Wafer Wear Life

The brush is one of the most important parts of the sweeper and its operations. The brush is a replaceable component that literally performs the hard work.

EXAMPLE OF WEAR LIFE

| | |
|--|-----------|
| Fine Asphalt | 1 Year |
| Finish Coated Asphalt | 6 Mos. |
| 1st Pass Asphalt | 3-4 Mons. |
| Milling (Ground up road surface) | 1 week |

These number will be greatly reduced if used in an incorrect manner.

Factors for Longer Brush Life.

- 1. BROOM LEVEL**
A broom not level with the sweeping surface may cut wafer life in excess of 50%.
For maximum broom wafer life the level of the broom must be checked daily. The time spend in checking and correcting the broom level will pay in the extended life of the broom wafers.
- 2. TURNING BROOM CORE**
Turning the broom core from end to end during the life of the brush will also extend its life. This turning helps prevent uneven wear caused by sweeping material from the same side, refer to page 2.17.

- 3. BRUSH DOWN PRESSURE**
The most common reason for short brush life is too much down pressure. By using the proper amount you can obtain maximum brush life.

The best sweeping action occurs by the "flicking" action of the bristles at their tips. By applying too much down pressure the bristles are using their "sides", this action greatly accelerates wear and reduces sweeping efficiency.

To limit down pressure, Terramite Street Sweepers are equipped with an adjustable spring assembly. Proper adjustment is shown in Figure 1.

- 4. PROPER GROUND SPEED**
Proper ground speed is important for the life of the brush. Running the machine too fast may allow material to accumulate in front of it. This build up of material creates pressure on the bristle "sides", which leads to their "wear".

For proper operation, sweep at high enough brush speed to discharge material and with proper ground speed to discharge the swept material from the sweepers path.

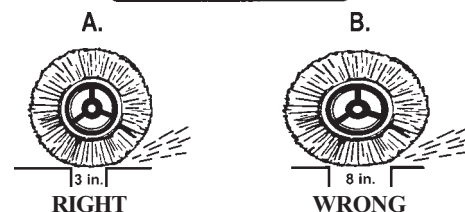

FIGURE 1
Brush Setting Decal and Proper Brush Setting

Broom Core Removal/Wafer Replacement

1. Place sweeper in level spot.
 2. Engage parking brake
 3. Turn off engine.
 4. Clean the broom head.
 5. Lower the sweeper head until the bristles just touch the surface.
 6. Remove the 3 bolts (Shown as “A” in Figure 1).
 7. Remove the bolt (Shown as “B” in Figure 1).
 8. Pull the motor assembly from the brush core and lay it to the side. **DO NOT REMOVE ANY HOSES!**
 9. Start the sweeper at low idle. Raise the broom head enough to allow the core to be completely removed. Turn off engine.
 10. If turning the broom for brush life, rotate broom core and skip to step. 16.
 11. Remove the (2) screws and cap plate (Shown as “A” in Figure 2).
 12. Remove wafers.
 13. Place a wafer onto the core with the drive pins between the tube (Shown in Figure 3 for proper placement and Figure 4 for improper placement).
 14. The next wafer is flipped as it is placed over the core and rotated 1/3 turn (Shown in Figure 4 for proper placement and Figure 5 for improper placement).
- NOTE: To have proper number of wafers it may be necessary to tap them with a heavy rubber hammer.**
- NOTE: For 1/2 wire and 1/2 poly place a poly wafer on each end.**
15. Reattach the end cap.
 16. Place broom core into broom head.
 17. Reattach the motor assembly.
 18. Check for proper operation.

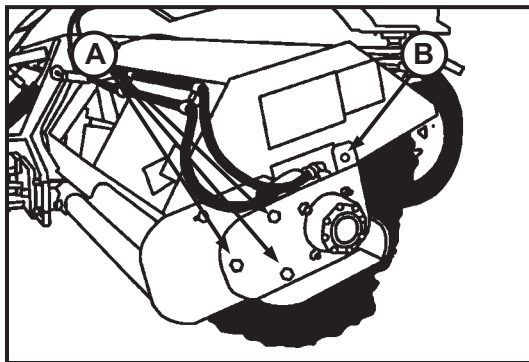

FIGURE 1

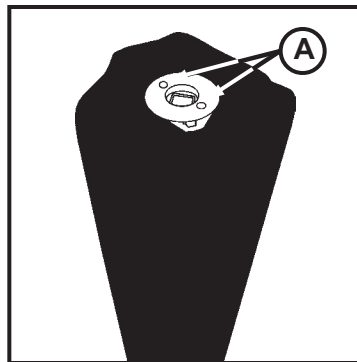

FIGURE 2

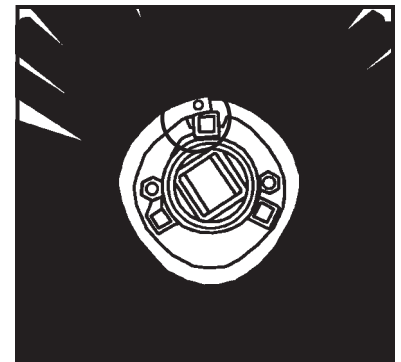

FIGURE 3
Proper Placement
of Drive Pins (Circled)



FIGURE 4
Improper Placement
of Drive Pins (Circled)

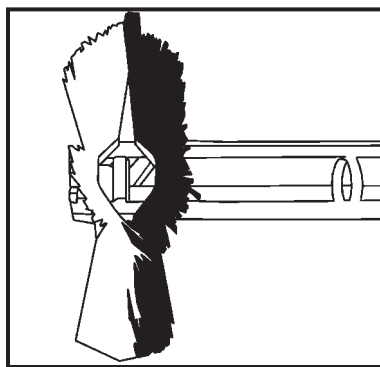

FIGURE 5
Proper Placement
of Wafers on Core

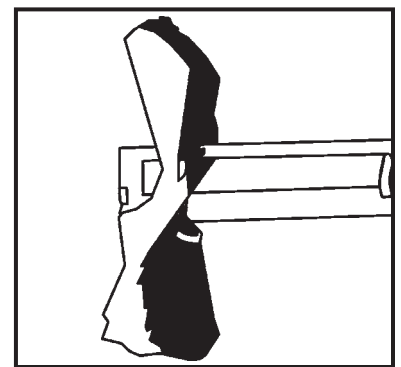

FIGURE 6
Improper Placement
of Wafers on Core

Service Operations

Setting and Adjusting Broom

1. Set the broom angle to that needed. (See Figures 1, 2 and 3).
2. Set broom level. (See Figure 4). Loosen the 3/4 lock nuts. (See Figure 5). Raise or lower broom motor to obtain consistant brush contact across full length of the broom.
3. Adjust broom contact. (See Figure 6).

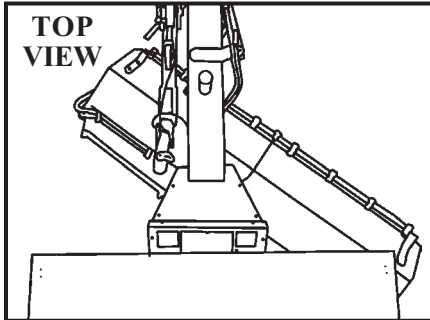

FIGURE 1
Angled Right

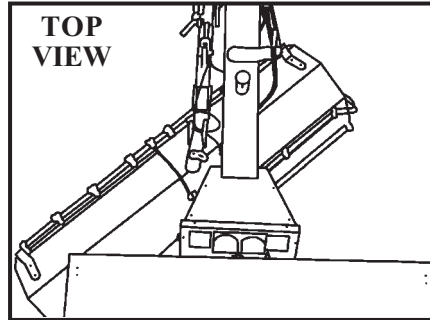

FIGURE 2
Angled Left

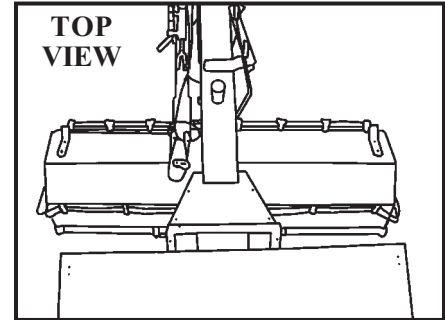

FIGURE 3
Straight

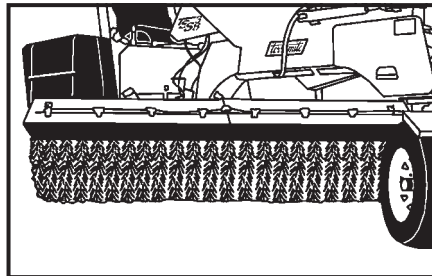

FIGURE 4
Horizontal Level

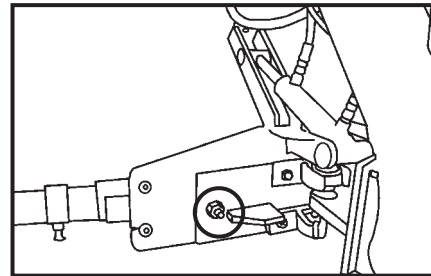

FIGURE 5
Lock Nut - Left Side (Circled)

BRUSH SETTING
SET BROOM DOWN PRESSURE TO MAINTAIN SWEEPING PATTERN WIDTH OF 3 INCHES MAX

⚠ WARNING ⚠

IMPROPER DOWN PRESSURE ADJUSTMENT CAUSES
• PREMATURE BRUSH WEAR OR DAMAGE
• POOR SWEEPING QUALITY

P/N 38195

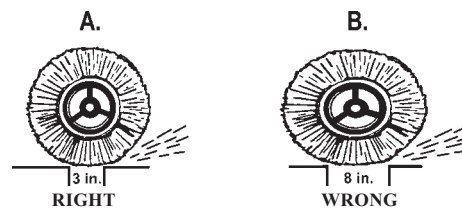
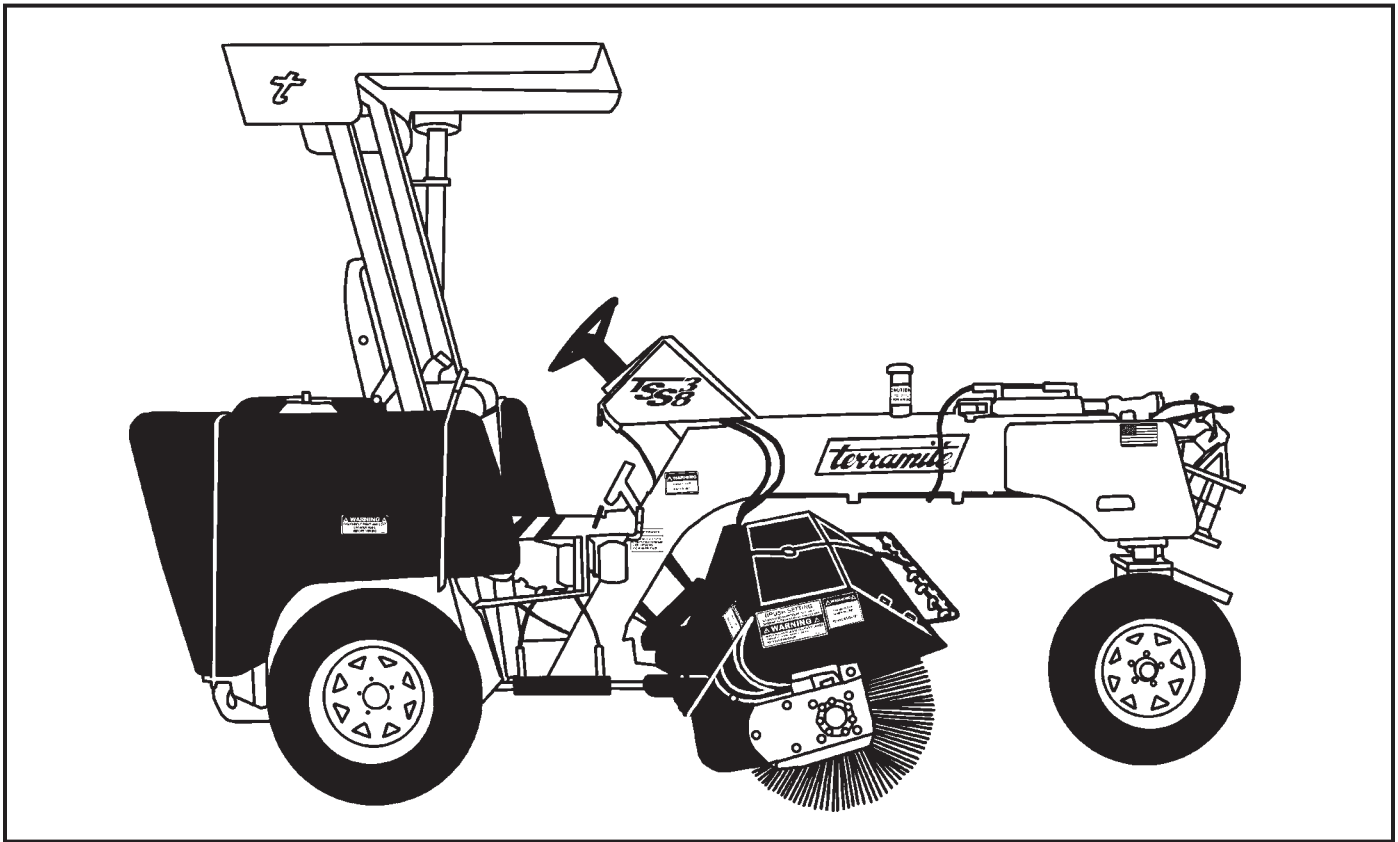
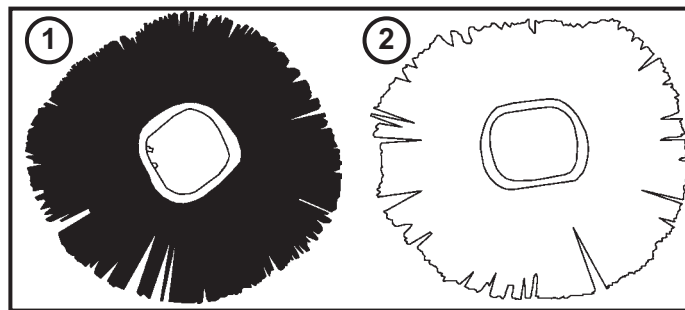

FIGURE 6 - Brush Setting Decal and Example of Proper Brush Setting

Please Note: Left or Right is Determined from the Operator's Position



Wafers



| ITEM | PART NUMBER | DESCRIPTION | QTY. |
|------|-------------|---|------|
| 1 | 38045 | Wafer, Poly, Brush, Sweeper 8 Ft. 25 Poly 6 Ft. 20 Poly | N/A |
| 2 | 38046 | Wafer, Wire, Brush, Sweeper 8 Ft. 24 Wire 6 Ft. 19 Wire | N/A |

Parts

View from Right Side of Operator's Position

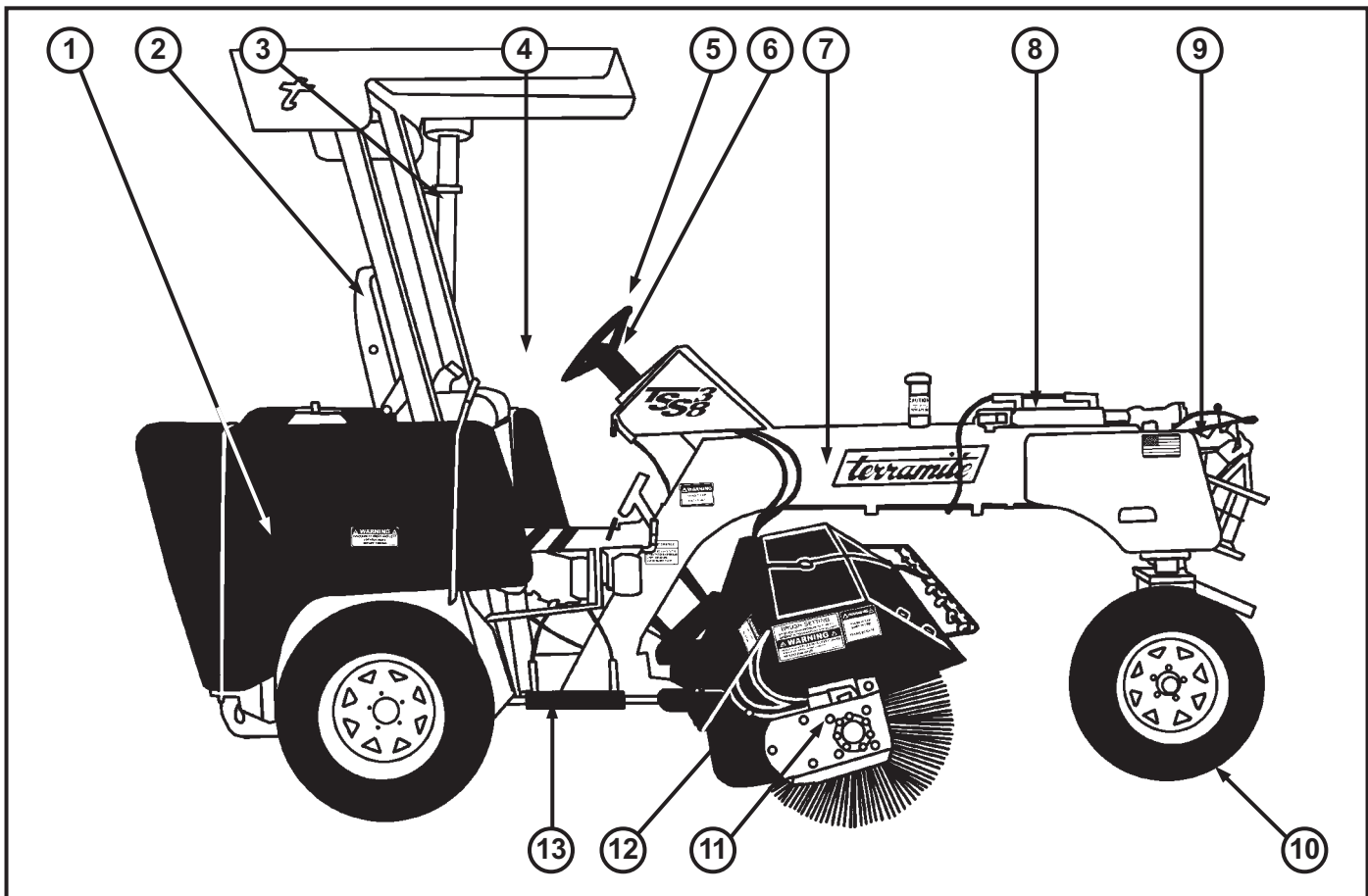

| ITEM | PART NUMBER | DESCRIPTION | QTY. |
|------|-------------|------------------------------------|------------------|
| 1 | 38390 | Tank, Water, Sweeper | 2 |
| 2 | 14083 | Seat, Sweeper/T5D/T7/T6/T9 | 1 |
| 3 | 38394 | Pipe, Air Inlet, Deutz, Sweeper | 1 |
| 4 | 38083 | Handle, Brake, Sweeper | 1 |
| 5 | 38061 | Wheel, Steering, Sweeper | 1 |
| 6 | 38537 | Gear, Steering, Sweeper | 1 |
| 7 | 38216 | Frame, Sweeper | 1 |
| 8 | 38015 | Cylinder, Steering, Sweeper | 1 |
| 9 | 38026 | Valve, Tow Bar, Sweeper | 1 |
| 10 | 38816 | Assembly, Tire & Wheel, Sweeper | 3 |
| 11 | 38052 | Motor, Brush Core Drive, Sweeper 2 | |
| 12 | 38306 | Bar, Brush Mount, Sweeper | 6 Foot Broom Bar |
| | 38307 | | 8 Foot Broom Bar |
| 13 | 38017 | Cylinder, Brush Angle, Sweeper | 1 |

View from Left Side of Operator's Position

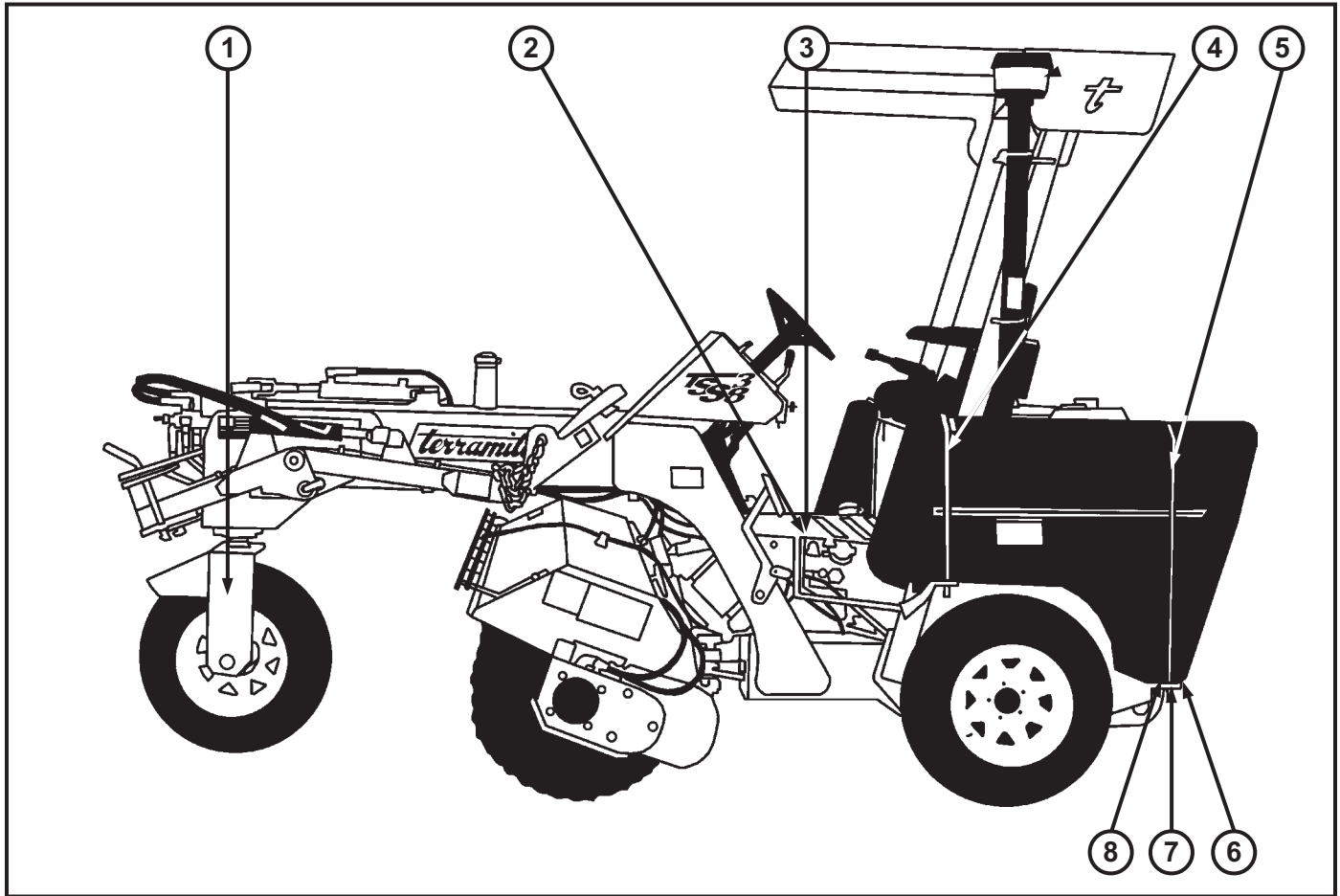

| ITEM | PART NUMBER | DESCRIPTION | QTY. |
|------|-------------|---|------|
| 1 | 38275 | Fork, Front, Sweeper | 1 |
| 2 | 38558 | Bolt, Eye, Brake Extension Spring, Sweeper | 1 |
| 3 | 38514 | Spring, Brake Extension, ³ / ₄ OD, Sweeper | 1 |
| | 38062 | Pre-Cleaner Assy | 1 |
| 4 | 38273 | Strap, Front Holding, Water Tank, Sweeper | 2 |
| 5 | 38272 | Strap, Rear Holding, Water Tank, Sweeper | 2 |
| 6 | 38440 | Fitting, ¹ / ₂ MP x ³ / ₈ HB90, Water Tank, Sweeper | 2 |
| 7 | 38637 | Strainer, Drain, Water Tank, Sweeper | 2 |
| 8 | 38580 | Plug, Drain, Water Tank, Sweeper | 2 |

Parts

View of Front with Tow Bar Extended

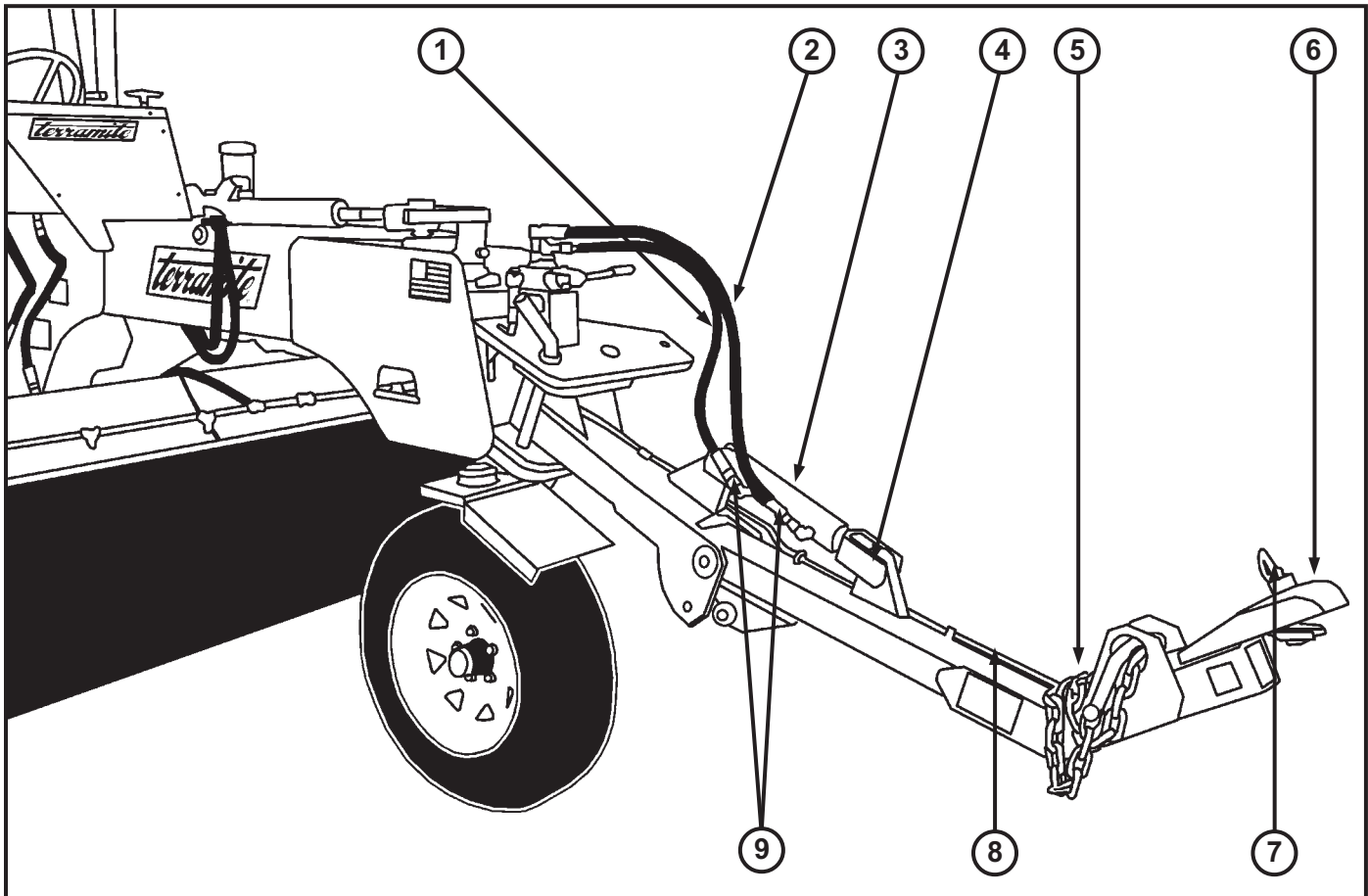

| ITEM | PART NUMBER | DESCRIPTION | QTY. |
|------|-------------|---|---------|
| 1 | 38101 | Hose, 3/8 x 31", #6FJIC Both, Cylinder, Tow Bar Lift, Sweeper | 1 |
| 2 | 38106 | Hose, 3/8 x 37", #6FJIC Both, Cylinder, Tow Bar Lift, Sweeper | 1 |
| 3 | 38018 | Cylinder, Tow-Bar Lift, Sweeper | 1 |
| 4 | 38420 | Pin, Tow-Bar Lift/Steering Cylinder, Sweeper | 6 |
| 5 | 38489 | Chain, Safety, Tow-Bar, Sweeper | 4.5 ft. |
| 6 | 38032 | Coupler, Tow-Bar Hitch, 2", Sweeper | 1 |
| 7 | 38622 | Kit, Tow-Bar Coupler, Sweeper | 1 |
| 8 | 38479 | Harness, Electrical, Tow-Bar, Sweeper | 1 |
| 9 | 38539 | Fitting, #6 O-Ring x #6MJIC90W/.016, Cylinder Hose, Tow-Bar Lift, Sweeper | 2 |

View of Tow Bar in Detail

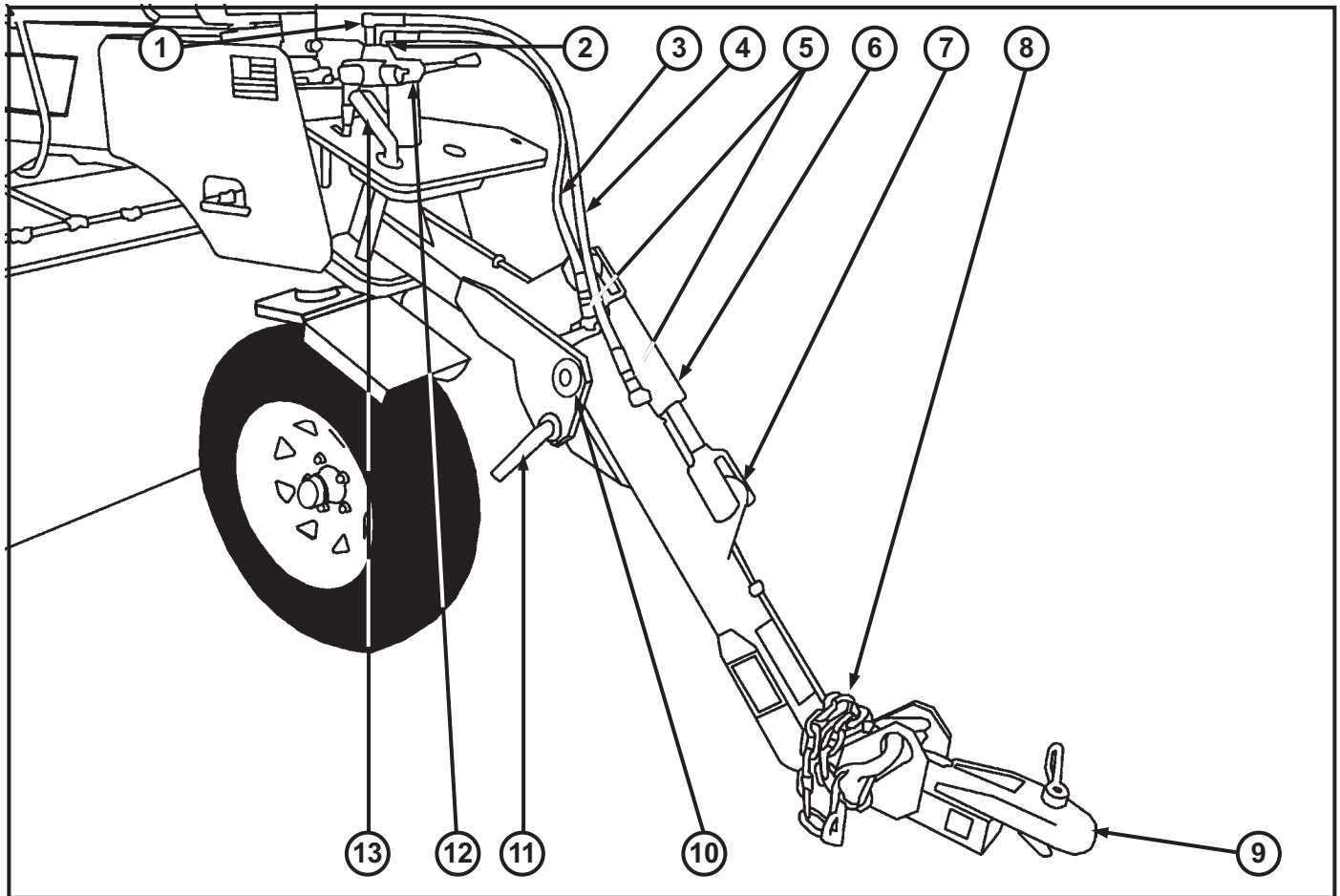

| ITEM | PART NUMBER | DESCRIPTION | QTY. |
|------|-------------|---|---------|
| 1 | 20156 | Fitting, #8 O-Ring x #6JIC90°, Tow-Bar Valve, Sweeper | 1 |
| 2 | 20149 | Fitting, #8MB O-Ring x #6JIC90°, Tow-Bar Valve, Sweeper | 3 |
| 3 | 38101 | Hose, 3/8 x 31", #6FJIC Both, Cylinder, Tow-Bar Lift, Sweeper | 1 |
| 4 | 38106 | Hose, 3/8 x 37", #6FJIC Both, Cylinder, Tow-Bar Lift, Sweeper | 1 |
| 5 | 38539 | Fitting, #6 O-Ring x #6MJIC90W/.016, Cylinder Hose, Tow-Bar Lift, Sweeper | 2 |
| 6 | 38018 | Cylinder, Tow-Bar Lift, Sweeper | 1 |
| 7 | 38420 | Pin, Tow-Bar Lift/Steering Cylinder, Sweeper | 6 |
| 8 | 38489 | Chain, Safety, Tow-Bar, Sweeper | 4.5 Ft. |
| 9 | 38032 | Coupler, Tow-Bar Hitch, 2", Sweeper | 1 |
| 10 | 38021 | Pin, Tow-Bar, Sweeper | 1 |
| 11 | 38023 | Pin, Lower Locking, Tow-Bar, Sweeper | 1 |
| 12 | 38026 | Valve, Tow Bar, Sweeper | 1 |
| 13 | 38042 | Pin, Upper Locking, Tow-Bar, Sweeper | 1 |

Parts

View of Lower Front

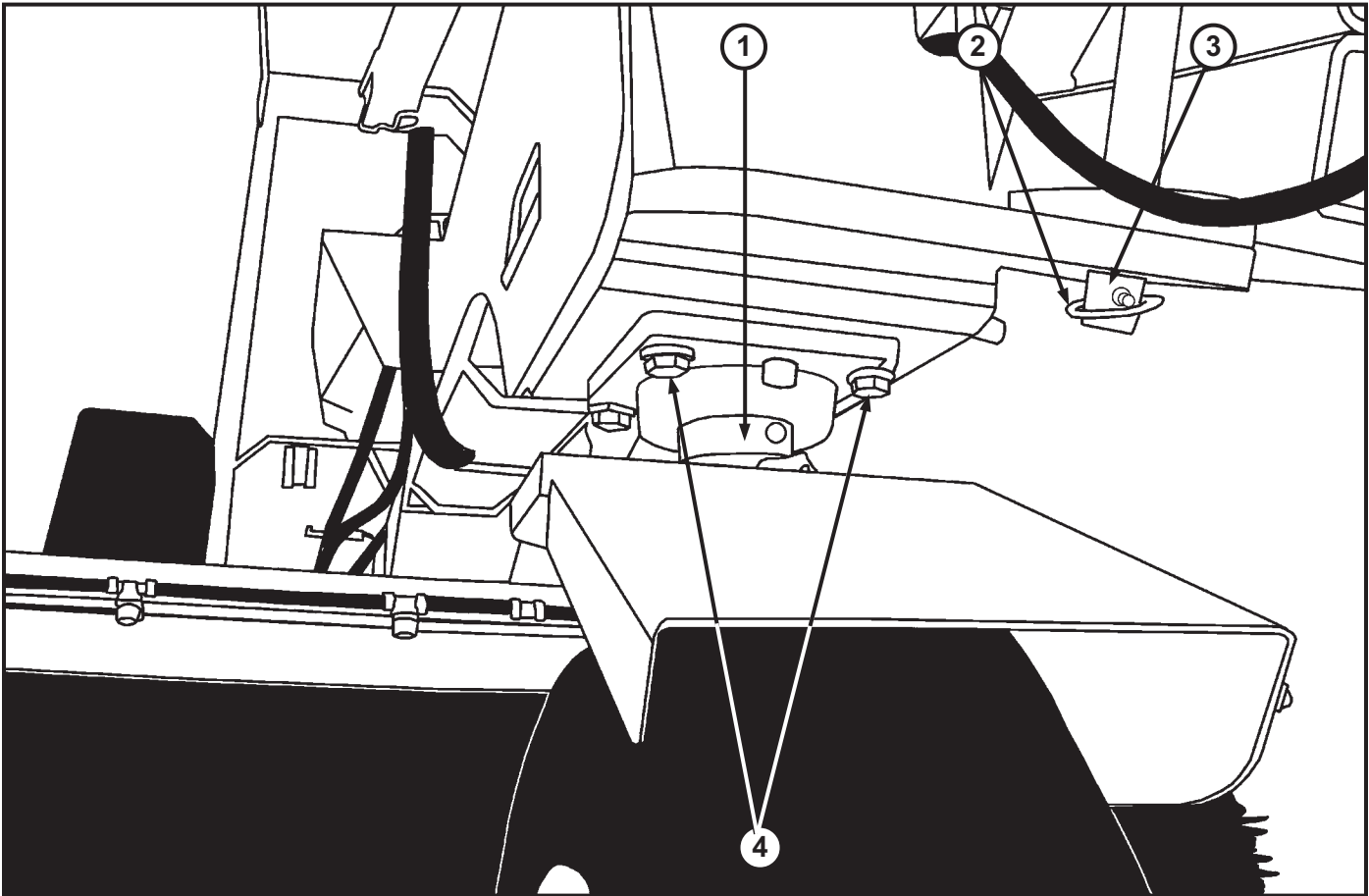

| ITEM | PART NUMBER | DESCRIPTION | QTY. |
|------|-------------|---|------|
| 1 | 38169 | Bearing, 4 Bolt Flange, Front Fork, Sweeper | 2 |
| 2 | 10202 | Pin, Linch, Tow-Bar Pivot Pin, Sweeper | 4 |
| 3 | 38021 | Pin, Tow-Bar, Sweeper | 1 |
| 4 | 22160 | Bolt, 5/8 x 2 1/4" GR8Z, Sweeper | 8 |

View of Front

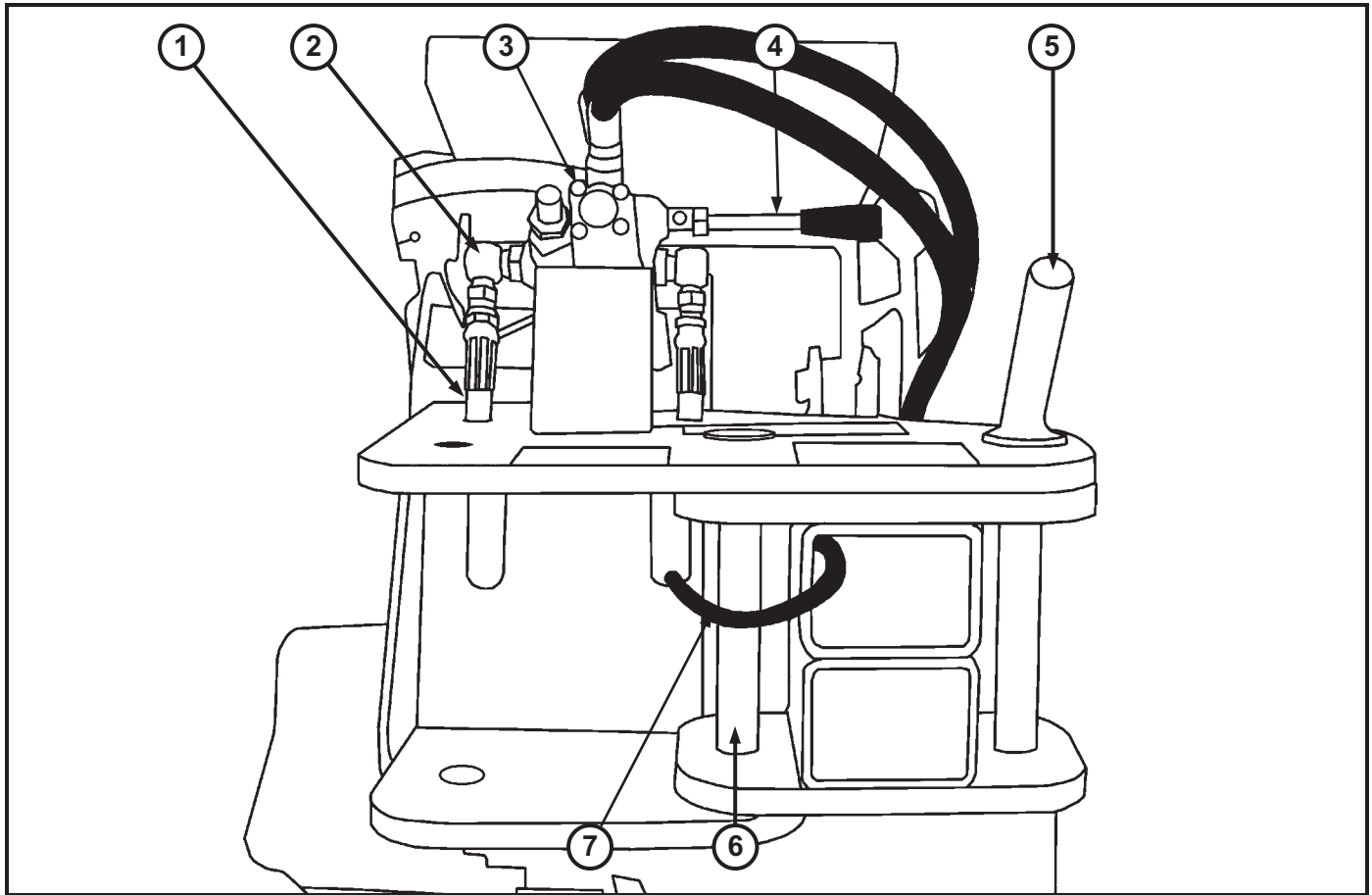

| ITEM | PART NUMBER | DESCRIPTION | QTY. |
|------|-------------|--|------|
| 1 | 38549 | Hose, ³ / ₈ x 92", #8FJIC x #6FJIC, Sweeper Kubota | 1 |
| | 38579 | Hose, ³ / ₈ x 96", #8 FJIC x #6FJIC, Sweeper Deutz | |
| 2 | 20149 | Fitting, #8MB O-Ring x #6JIC90°, Tow-Bar Valve, Sweeper | 3 |
| 3 | 38026 | Valve, Tow-Bar, Sweeper | 1 |
| 4 | 38659 | Handle, Tow Bar Valve, Sweeper | 1 |
| 5 | 38042 | Pin, Upper Locking, Tow-Bar, Sweeper | 1 |
| 6 | 38021 | Pin, Tow-Bar, Sweeper | 1 |
| 7 | 38453 | Harness, Electrical, Tow-Bar, Sweeper | 1 |

Parts

View of Right Front

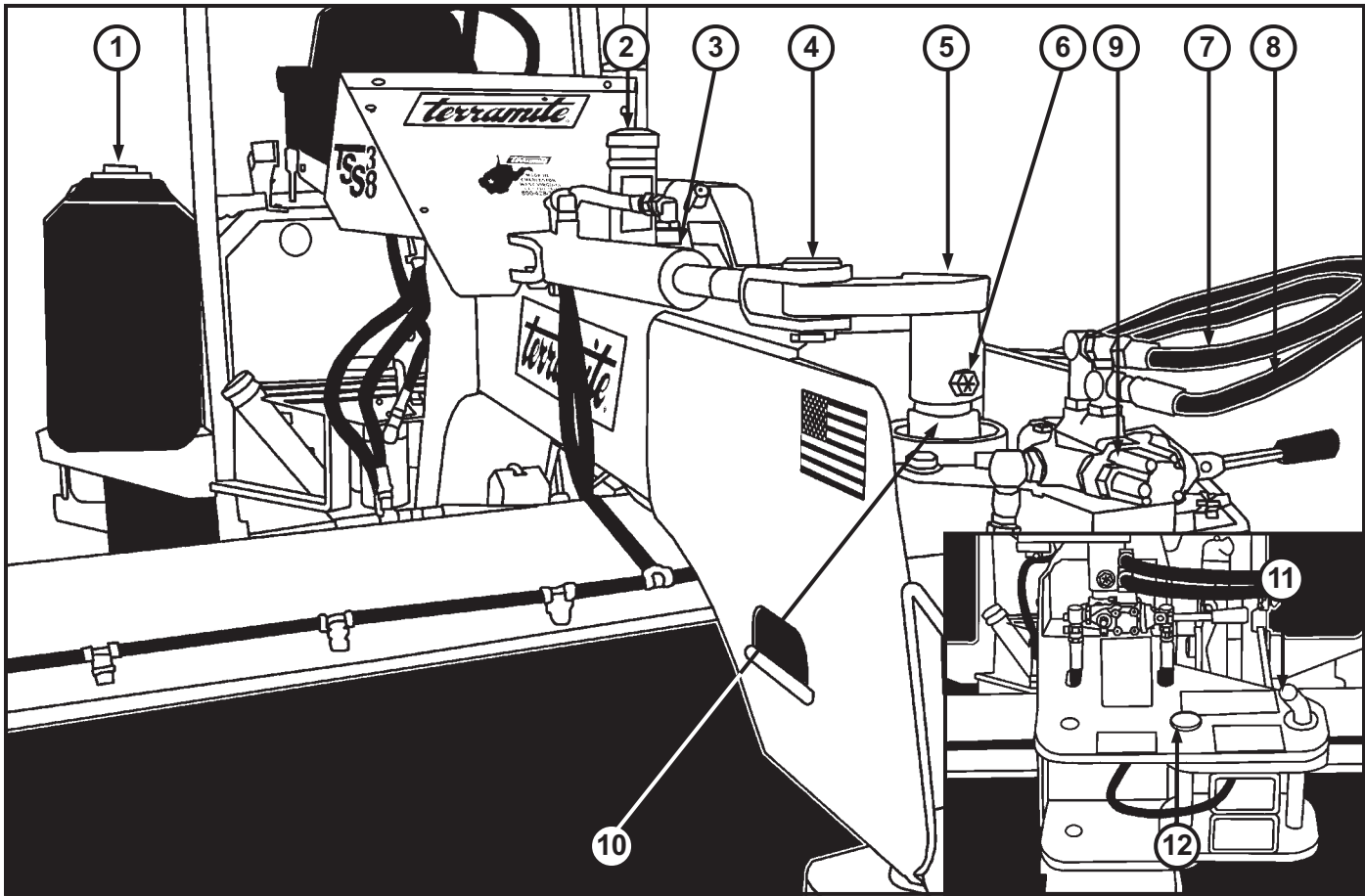

| ITEM | PART NUMBER | DESCRIPTION | QTY. |
|------|-------------|---|------|
| 1 | 38532 | Cap, Water Tank Fill, Sweeper | 2 |
| 2 | 38013 | Cap, Locking, Fuel/Hydraulic Filler, Sweeper | 2 |
| 3 | 38015 | Cylinder, Steering, Sweeper | 1 |
| 4 | 38420 | Pin, Tow-Bar Lift/Steering Cylinder, Sweeper | 2 |
| 5 | 38282 | Arm, Steering, Sweeper | 1 |
| 6 | 22158 | Bolt, 1/2 x 3 1/4" GR8, Sweeper | 1 |
| 7 | 38106 | Hose, 3/8 x 37", #6FJIC Both, Cylinder, Tow-Bar Lift, Sweeper | 1 |
| 8 | 38101 | Hose, 3/8 x 31", #6FJIC Both, Cylinder, Tow-Bar Lift, Sweeper | 1 |
| 9 | 38026 | Valve, Tow-Bar, Sweeper | 1 |
| 10 | 38169 | Bearing, 4 Bolt Flange, Front Fork, Sweeper | 2 |
| 11 | 38023 | Pin, Upper Locking, Tow-Bar, Sweeper | 1 |
| 12 | 38021 | Pin, Tow-Bar, Sweeper | 1 |

View of Right Side Front

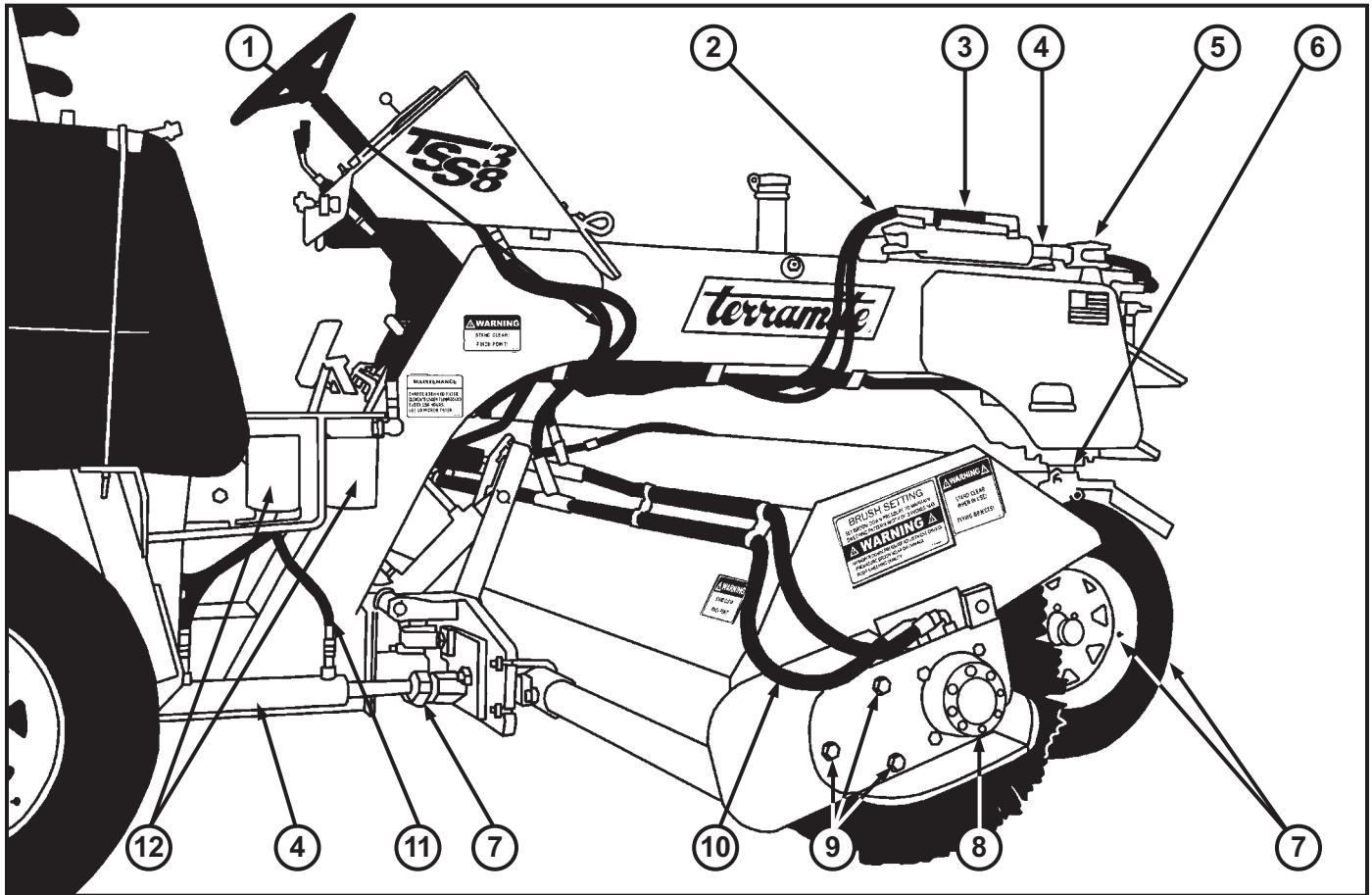

| ITEM | PART NUMBER | DESCRIPTION | QTY. |
|------|-------------|---|------|
| 1 | 38096 | Hose, 1/2 x 39", #8FJIC x #8JICF90°, Sweeper | 1 |
| 2 | 38551 | Hose, 3/8 x 74", #6FJIC x #6FJIC90°, Sweeper | 1 |
| 3 | 38550 | Hose, 3/8 x 84", #6FJIC x #6FJIC90°, Sweeper | 1 |
| 4 | 38015 | Cylinder, Steering, Sweeper | 1 |
| 5 | 38420 | Pin, Tow-Bar Lift/Steering Cylinder, Sweeper | 6 |
| 6 | 38169 | Bearing, 4 Bolt Flange, Front Fork, Sweeper | 2 |
| 7 | 38816 | Assembly, Tire & Wheel, Sweeper | 3 |
| 8 | 38232 | Motor, Brush Core Drive, Sweeper | 2 |
| 9 | 22154 | Bolt, 1/2 - 13 x 11/2" NC Gr 8Z, Sweeper/T5C/D/G/T7 | 6 |
| 10 | 38129 | Hose, 1/2 x 54", #8FJIC x #8FJIC90°, Sweeper | 2 |
| 11 | 38112 | Hose, 3/8 x 48", #6FJIC both, Sweeper | 2 |
| 12 | 21002 | Filter, Hydraulic, Sweeper | 2 |

Parts

View of Right Side Front

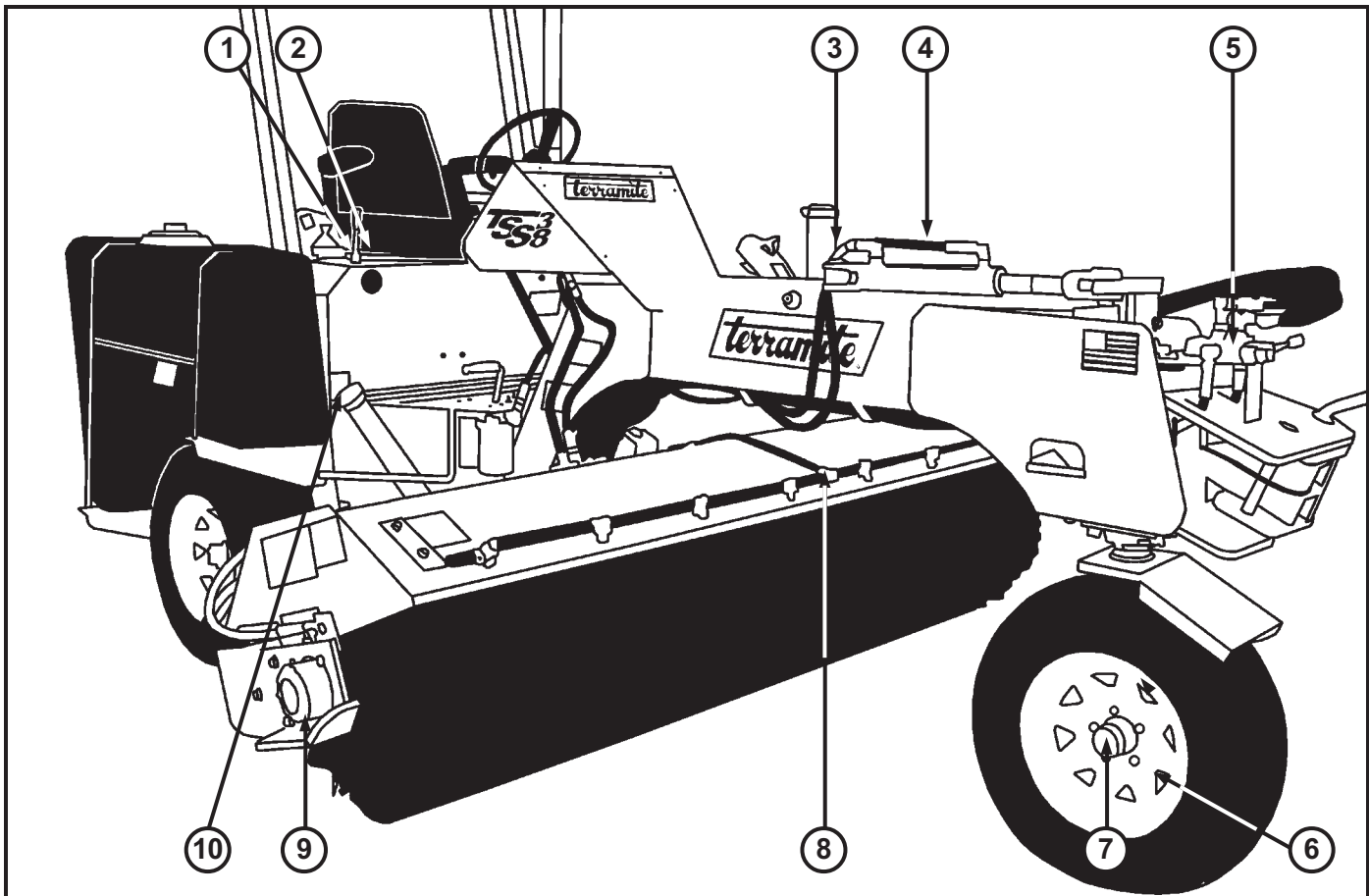

| ITEM | PART NUMBER | DESCRIPTION | QTY. |
|------|-------------|---|------|
| 1 | 38565 | Boot, Forward/Reverse Valve, Sweeper | 1 |
| 2 | 38086 | Valve, Forward/Reverse, Sweeper | 1 |
| 3 | 38551 | Hose, ³ / ₈ x 74", #6FJIC x #6FJIC90°, Sweeper | 1 |
| 4 | 38550 | Hose, ³ / ₈ x 84", #6FJIC x #6FJIC90°, Sweeper | 1 |
| 5 | 38026 | Valve, Tow-Bar, Sweeper | 1 |
| 6 | 38816 | Assembly, Tire & Wheel, Sweeper | 3 |
| 7 | 38047 | Kit, Front Hub, Sweeper | 1 |
| 8 | 20135 | Fitting, ³ / ₈ HBT 29 Brass, Waterline, Sweeper | 2 |
| 9 | 38052 | Motor, Brush Core Drive, Sweeper | 2 |
| 10 | 38013 | Cap, Locking, Fuel/Hydraulic Filler, Sweeper | 2 |

View of Left Side Front

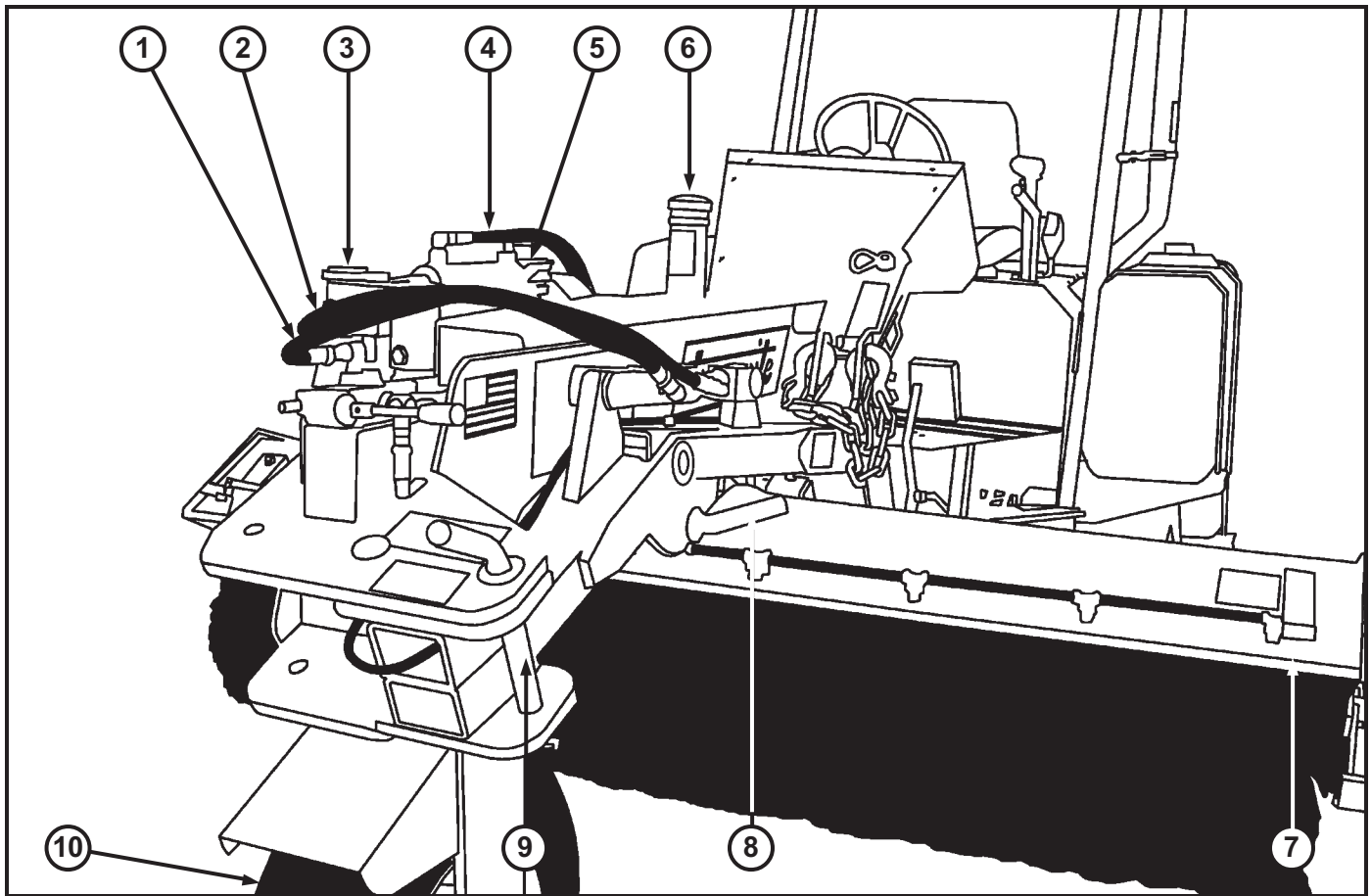

| ITEM | PART NUMBER | DESCRIPTION | QTY. |
|------|-------------|---|------|
| 1 | 38101 | Hose, 3/8 x 31", #6FJIC Both, Cylinder, Tow-Bar Lift, Sweeper | 1 |
| 2 | 38106 | Hose, 3/8 x 37", #6FJIC Both, Cylinder, Tow-Bar Lift, Sweeper | 1 |
| 3 | 38420 | Pin, Tow-Bar Lift/Steering Cylinder, Sweeper | 6 |
| 4 | 38550 | Hose, 3/8 x 84", #6FJIC x #6FJIC90°, Sweeper | 1 |
| 5 | 38015 | Cylinder, Steering, Sweeper | 1 |
| 6 | 38013 | Cap, Locking, Fuel/Hydraulic Filler, Sweeper | 2 |
| 7 | 38304 | Bar, Spray, Sweeper 6 Foot Brush | 1 |
| | 38305 | Bar, Spray, Sweeper 8 Foot Brush | |
| 8 | 38023 | Pin, Lower Locking, Tow-Bar, Sweeper | 1 |
| 9 | 38042 | Pin, Upper Locking, Tow-Bar, Sweeper | 1 |
| 10 | 38048 | Assembly, Tire & Wheel, Sweeper | 3 |

Parts

View of Left Side

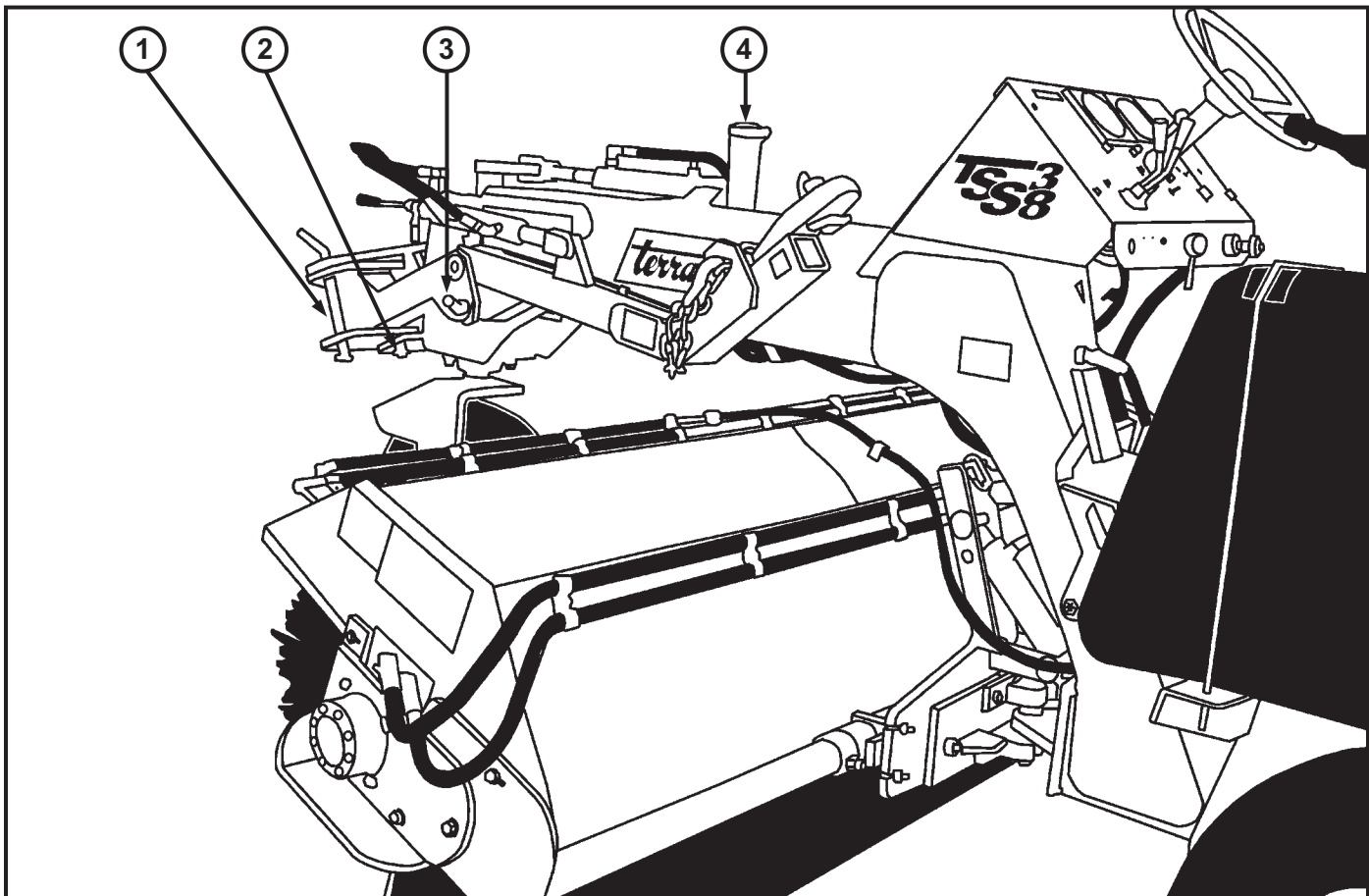

| ITEM | PART NUMBER | DESCRIPTION | QTY. |
|------|-------------|--|------|
| 1 | 38042 | Pin, Upper Locking, Tow-Bar, Sweeper | 1 |
| 2 | 38021 | Pin, Tow-Bar, Sweeper | 1 |
| 3 | 38023 | Pin, Lower Locking, Tow-Bar, Sweeper | 1 |
| 4 | 38013 | Cap, Locking, Fuel/Hydraulic Filler, Sweeper | 2 |

View of Right Side Brush Assembly

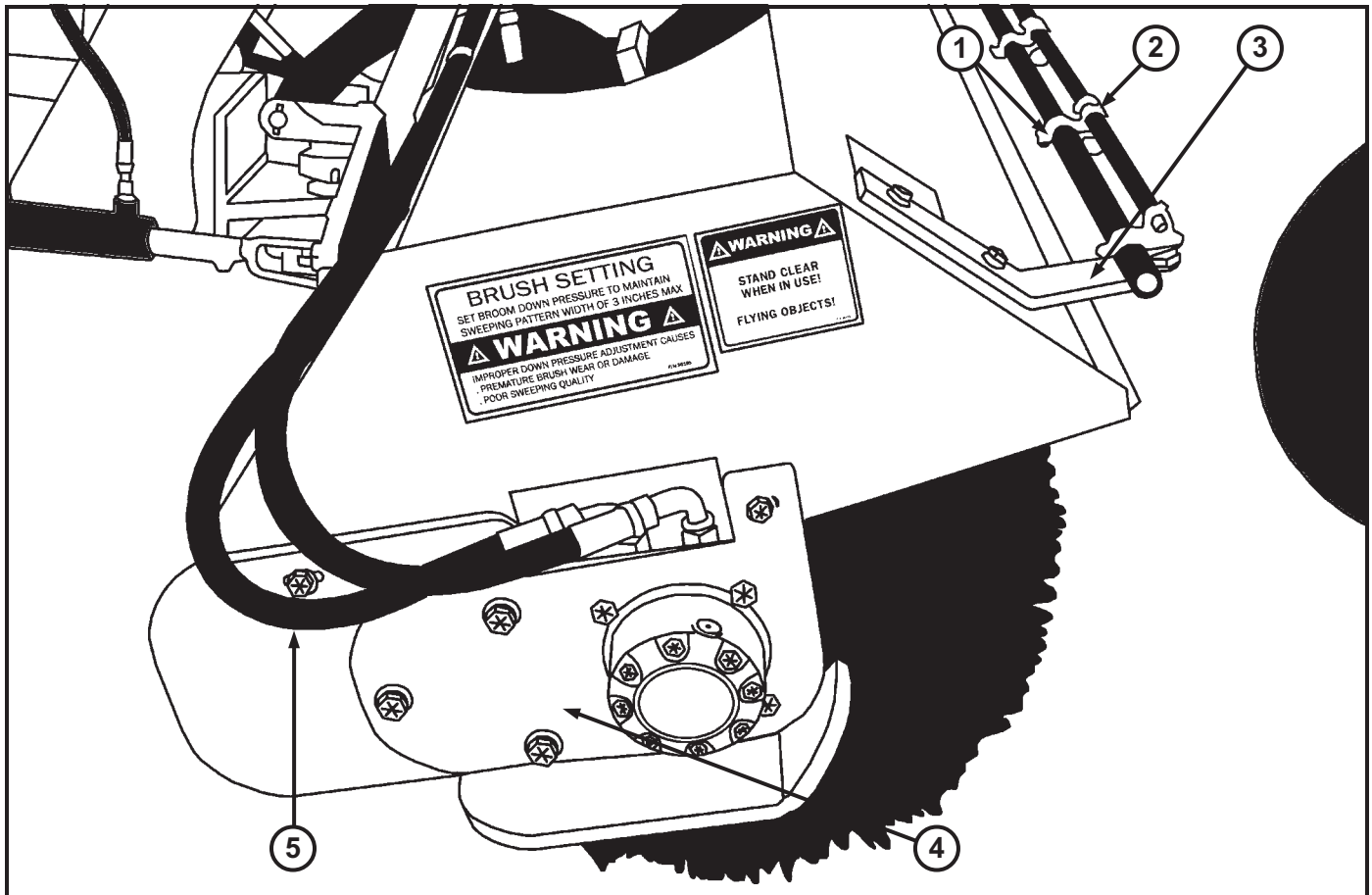

| ITEM | PART NUMBER | DESCRIPTION | QTY. |
|------|-------------|--|------|
| 1 | 38162 | Clamp, Spray Bar to Push Lock Hose, Sweeper | 8 |
| 2 | 38176 | Clamp, 19/32", Spray Orifice, Sweeper | 16 |
| 3 | 38304 | Bar, Spray, Sweeper 6 Foot Brush | 1 |
| | 38305 | Bar, Spray, Sweeper 8 Foot Brush | |
| 4 | 38402 | Mount, Brush Core Motor, Sweeper Left Side | 1 |
| | 38403 | Mount, Brush Core Motor, Sweeper Right Side | |
| 5 | 38571 | Hose, #8FJIC x #8FJIC90°, 8 Ft. Brush, Sweeper, Left Side 1/2 x 74" | 2 |
| | 38129 | Hose, #8FJIC x #8FJIC90°, 8 Ft. Brush, Sweeper, Right Side 1/2 x 54" | |
| | 38132 | Hose, #8FJIC x #8FJIC90°, 6 Ft. Brush, Sweeper, Left Side 1/2 x 62" | 2 |
| | 38096 | Hose, #8FJIC x #8FJIC90°, 6 Ft. Brush, Sweeper, Right Side 1/2 x 39" | |

Parts

View of Left Side Brush Assembly

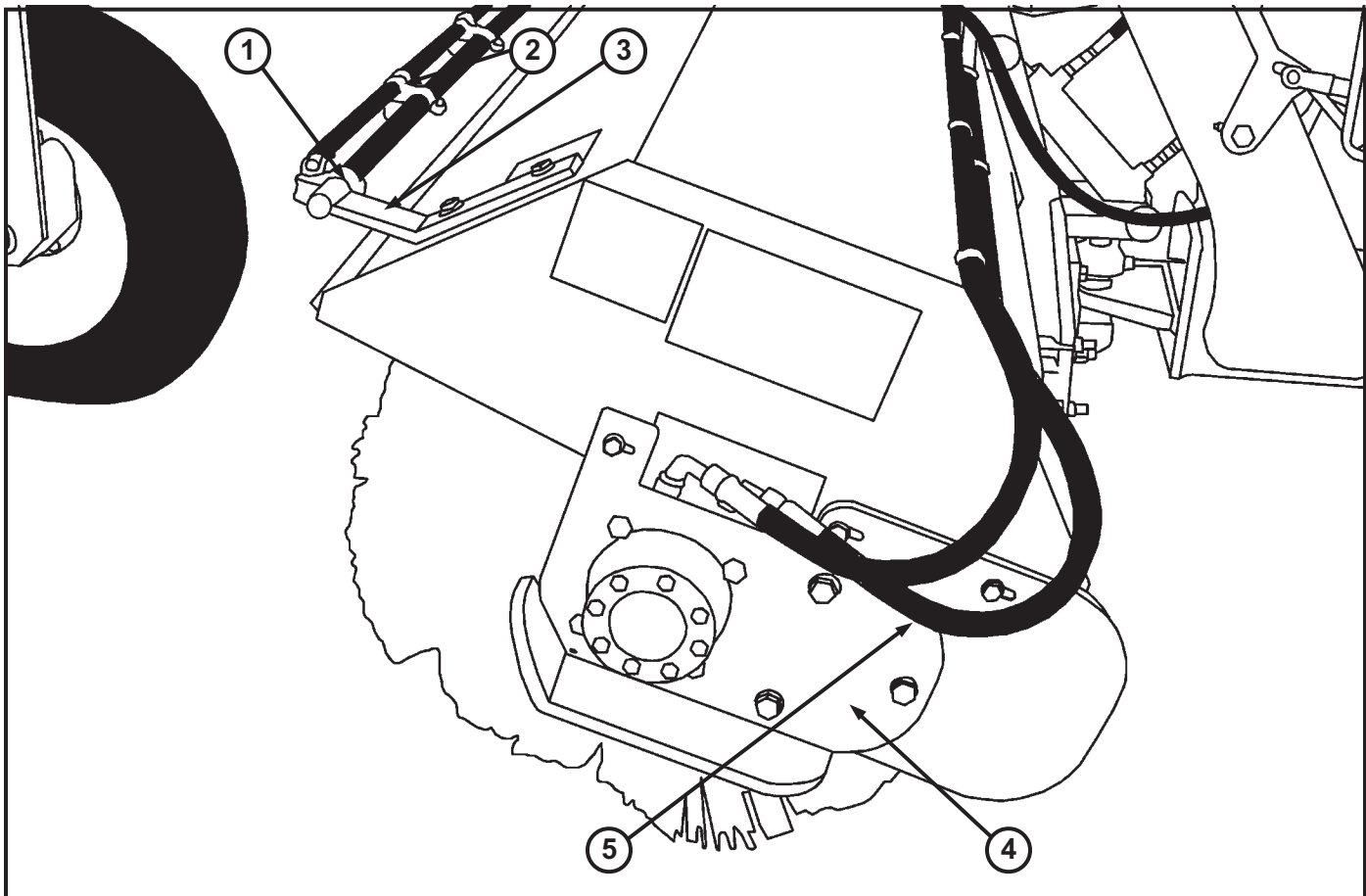

| ITEM | PART NUMBER | DESCRIPTION | QTY. |
|------|-------------|---|------|
| 1 | 38162 | Clamp, Spray Bar to Push Lock Hose, Sweeper | 8 |
| 2 | 38176 | Clamp, 1 ⁹ / ₃₂ " , Spray Orifice, Sweeper | 16 |
| 3 | 38304 | Bar, Spray, Sweeper 6 Foot Brush | 1 |
| | 38305 | 8 Foot Brush | |
| 4 | 38402 | Mount, Brush Core Motor, Sweeper Left Side | 1 |
| | 38403 | Right Side | |
| 5 | 38571 | Hose, #8FJIC x #8FJIC90°, 8 Ft. Brush, Sweeper, Left Side 1/2 x 74" | 2 |
| | 38129 | Right Side 1/2 x 54" | |
| | 38132 | Hose, #8FJIC x #8FJIC90°, 6 Ft. Brush, Sweeper, Left Side 1/2 x 62" | 2 |
| | 38096 | Right Side 1/2 x 39" | |

View of Lower Right

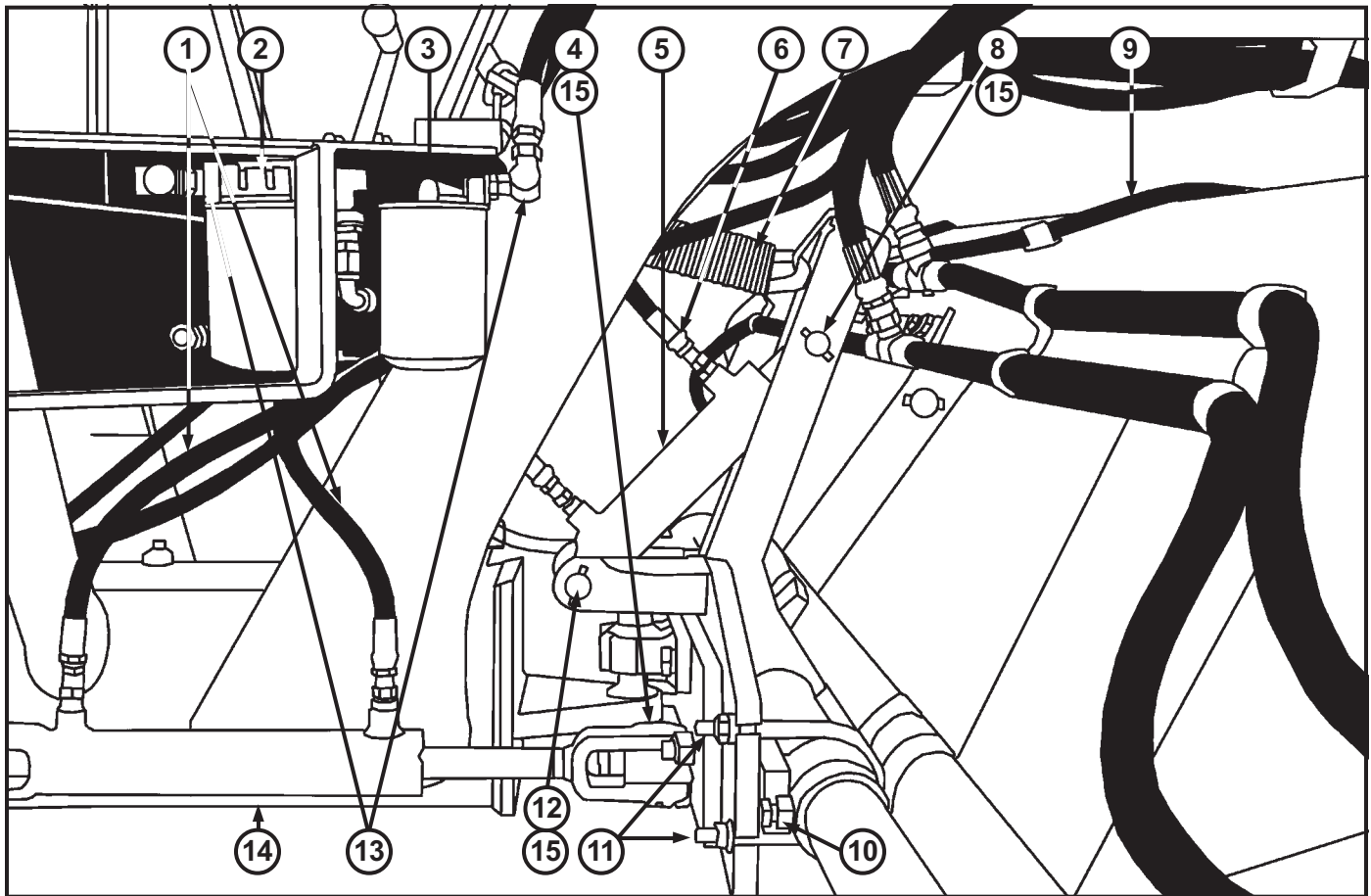

| ITEM | PART NUMBER | DESCRIPTION | QTY. |
|------|-------------|--|--------|
| 1 | 38112 | Hose, 3/8 x 48", #6FJIC Both, Sweeper | 2 |
| 2 | 38075 | Head, Filter, Blocked-By-Pass, Sweeper | 1 |
| 3 | 38074 | Head, Filter, 25PSI, Relief, Sweeper | 1 |
| 4 | 38420 | Pin, 1" x 2 1/8" Lg., Steering Cylinder, Sweeper | 1 |
| 5 | 38016 | Cylinder, Brush Lift, Sweeper | 1 |
| 6 | 38110 | Hose, 3/8 x 30", #6FJIC Both, Sweeper | 1 |
| 7 | 38399 | Spring, Large, Frame to Boom, Sweeper | 1 |
| 8 | 38422 | Pin, 1" x 4 1/2" Lg., Top Broom Lift, Sweeper | 1 |
| 9 | 38387 | Hose, 3/8", Push Lock, Sweeper | By Ft. |
| 10 | 28019 | Bolt, 1/2 x 1" GR8, Sweeper | 2 |
| 11 | 22168 | U-Bolt, W/Nuts "U", 1/2NF x 3IW x 6"L, Sweeper | 2 |
| 12 | 38421 | Pin, 1" x 5 1/8" Lg., Broom Lift, Sweeper | 2 |
| 13 | 20172 | Fitting, 1/2MP x #8MJIC90°, Sweeper | 4 |
| 14 | 38017 | Cylinder, Brush Angle, Sweeper | 1 |
| 15 | 38506 | Pin, Roll 1/4" x 1 1/2", Sweeper | 7 |

Parts

View of Lower Left

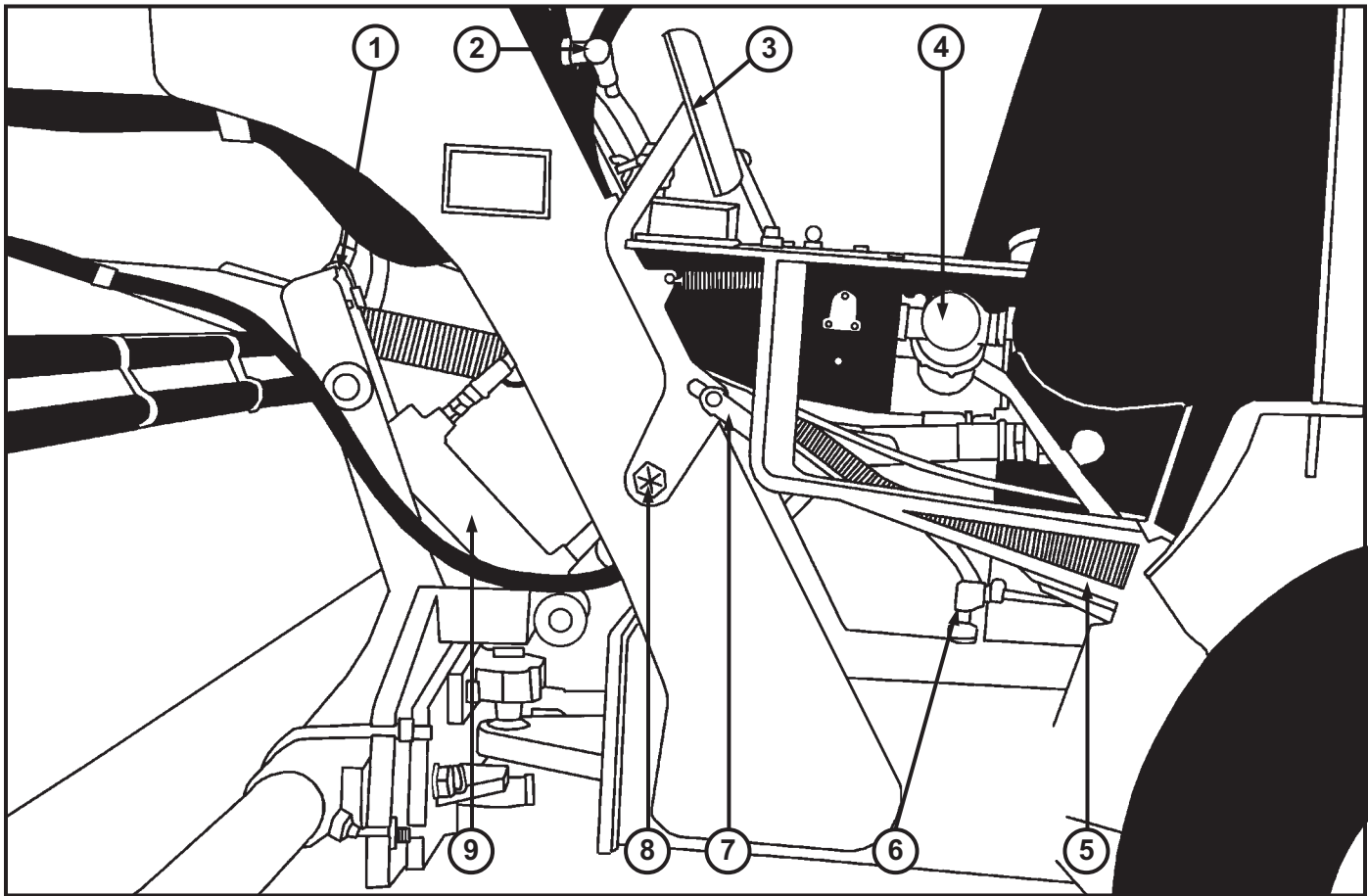

| ITEM | PART NUMBER | DESCRIPTION | QTY. |
|------|-------------|--|------|
| 1 | 38210 | Link, Quick, 5/16", Sweeper | 1 |
| 2 | 20172 | Fitting, 1/2MP x #8MJIC90°, Sweeper | 1 |
| 3 | 38465 | Pedal, Brake, Sweeper | 1 |
| 4 | 38165 | Filter, Suction, Water-Pump, Sweeper | 1 |
| 5 | 37464 | Assembly, Rod Brake Pedal, Sweeper | 1 |
| 6 | 38604 | Fitting, Fuel Tank, 1/4FM x 1/4" FM90°, Sweeper | 1 |
| 7 | 38475 | Yoke, Lever, Brake, 1/2" - 20 NF, Sweeper | 2 |
| 8 | 38515 | Bolt, Shoulder, Pedal, 3/4 - 10 x 4" NC, Sweeper | 1 |
| 9 | 38016 | Cylinder, Brush Lift, Sweeper | 1 |

View of Dash

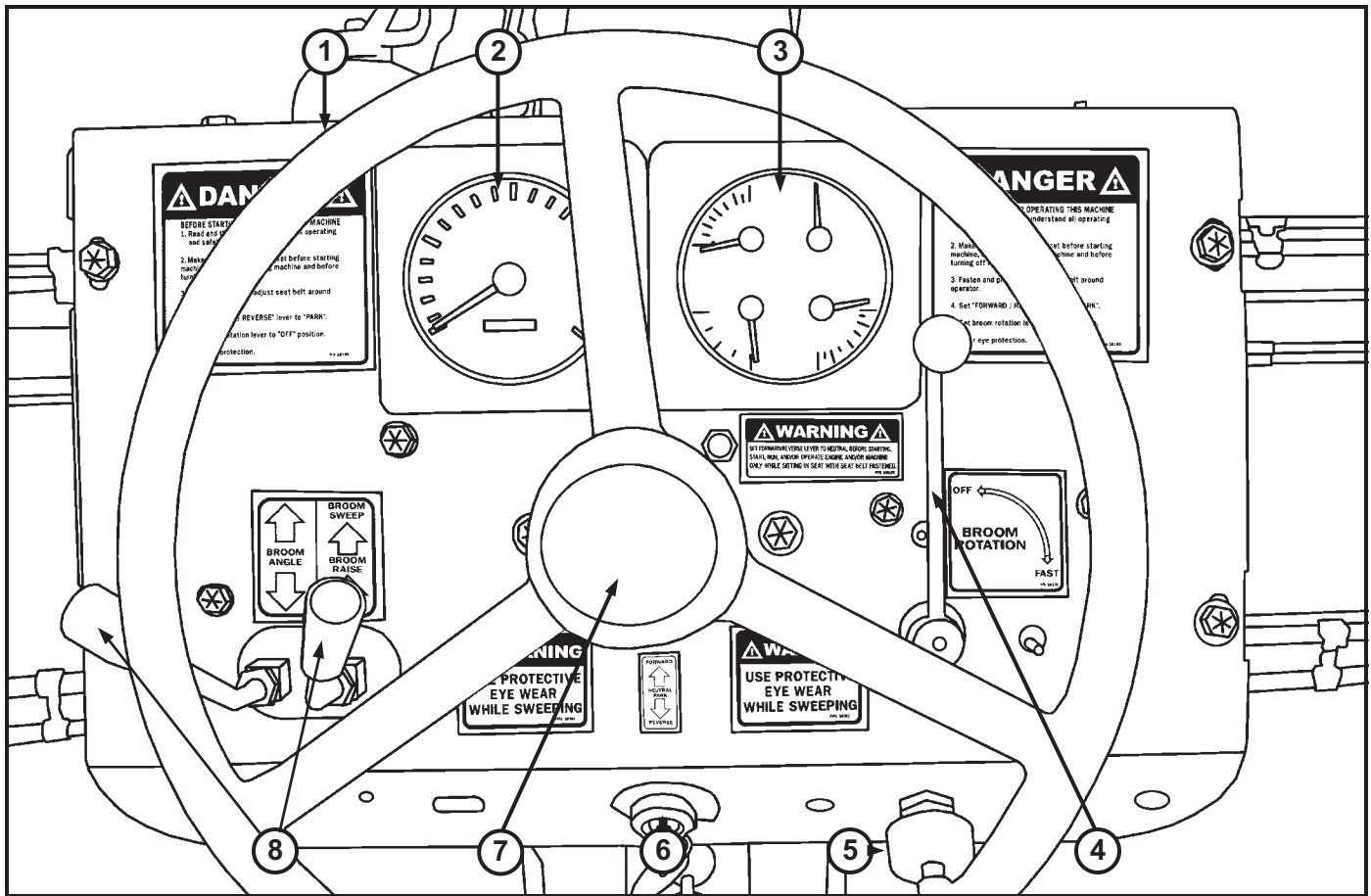

| ITEM | PART NUMBER | DESCRIPTION | QTY. |
|------|-------------|--|------|
| 1 | 38061 | Wheel, Steering, Sweeper | 1 |
| 2&3 | 72225 | New Kit | 1 |
| 4 | 38393 | Lever, Brush Speed, Sweeper | 1 |
| 5 | 38391 | Cable, Throttle, Sweeper | 1 |
| | 38502 | Kubota Deutz | |
| 6 | 70040 | Switch, Ignition, Sweeper | 1 |
| | 38590 | Kubota - T5D/T7 Deutz | |
| 7 | 38077 | Cap, Steering Wheel, Sweeper | 1 |
| 8 | 38660 | Handle, Boom Lift/Angle Valve, Sweeper | 2 |

Parts

View of Under Dash

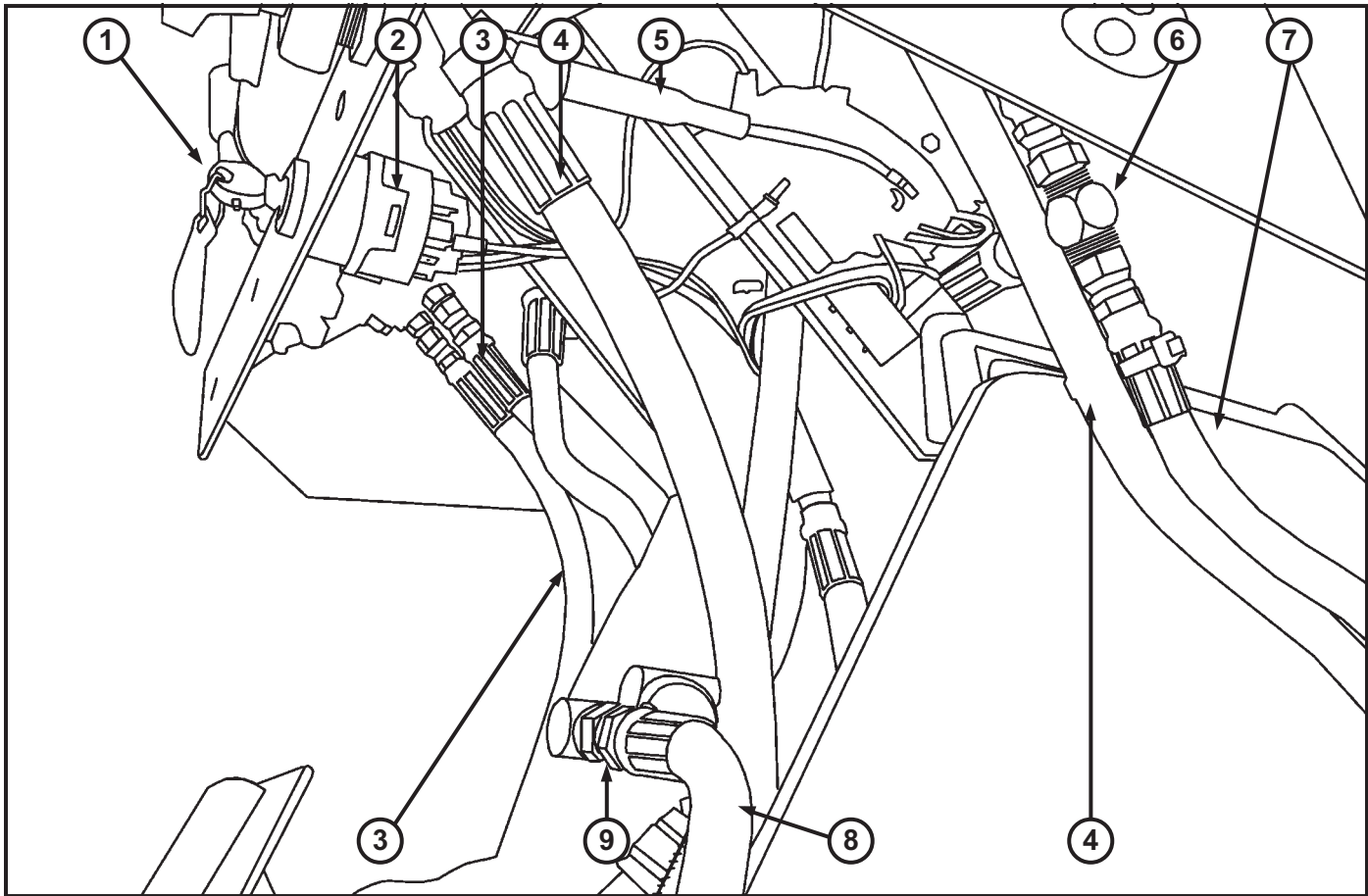

| ITEM | PART NUMBER | DESCRIPTION | QTY. |
|------|-------------|--|------|
| 1 | 38719 | Key, Ignition, Sweeper Deutz | 2 |
| | 70041 | Kubota - T5D/T7 | |
| 2 | 38590 | Switch, Ignition, Sweeper Deutz | 1 |
| | 70040 | Kubota - T5D/T7 | |
| 3 | 38112 | Hose, 3/8 x 48", #6FJIC Both, Sweeper | 2 |
| 4 | 38096 | Hose, 1/2 x 39", #8FJIC x #8FJIC90°, Sweeper | 2 |
| 5 | 38502 | Cable, Throttle, Sweeper Deutz | 1 |
| | 38391 | Kubota | |
| 6 | 20109 | Fitting, #8MJIC "T", Sweeper | 1 |
| 7 | 38520 | Hose, 1/2 x 29", FX08W/hy08-08 FJ, Sweeper | 1 |
| 8 | 38521 | Hose, 1/2 x 10 1/2", FX08W/hy08, Sweeper | 1 |
| 9 | 20172 | Fitting, 1/2MP x #8MJIC90°, Sweeper | 1 |

View of Behind Dash

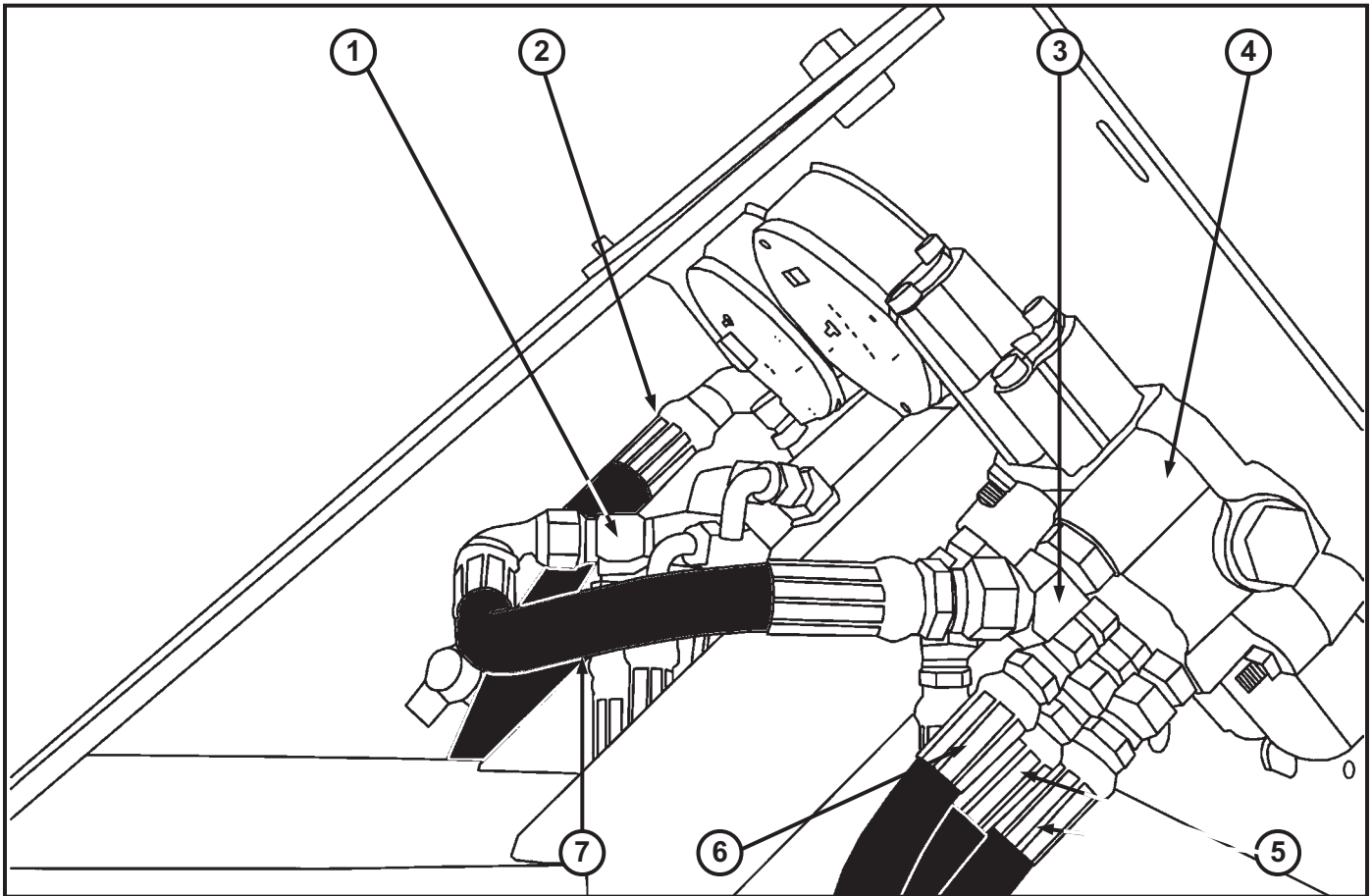

| ITEM | PART NUMBER | DESCRIPTION | QTY. |
|------|-------------|--|------|
| 1 | 38566 | Fitting, #8 Swivel Nut Run "T", Sweeper | 1 |
| 2 | 38096 | Hose, 1/2 x 39", #8FJIC x #8FJIC90°, Sweeper | 2 |
| 3 | 20179 | Fitting, #8 O-Ring x #8JICM45°, Sweeper | 1 |
| 4 | 38087 | Valve, Lift/Angle, Sweeper | 1 |
| 5 | 38112 | Hose, 3/8 x 48", #6FJIC Both, Sweeper | 2 |
| 6 | 38110 | Hose, 3/8 x 30", #6FJIC Both, Sweeper | 1 |
| 7 | 38570 | Hose, 1/2 x 13", #8FJIC x #8FJIC90°, Sweeper | 1 |

Parts

View of Underside of Dash

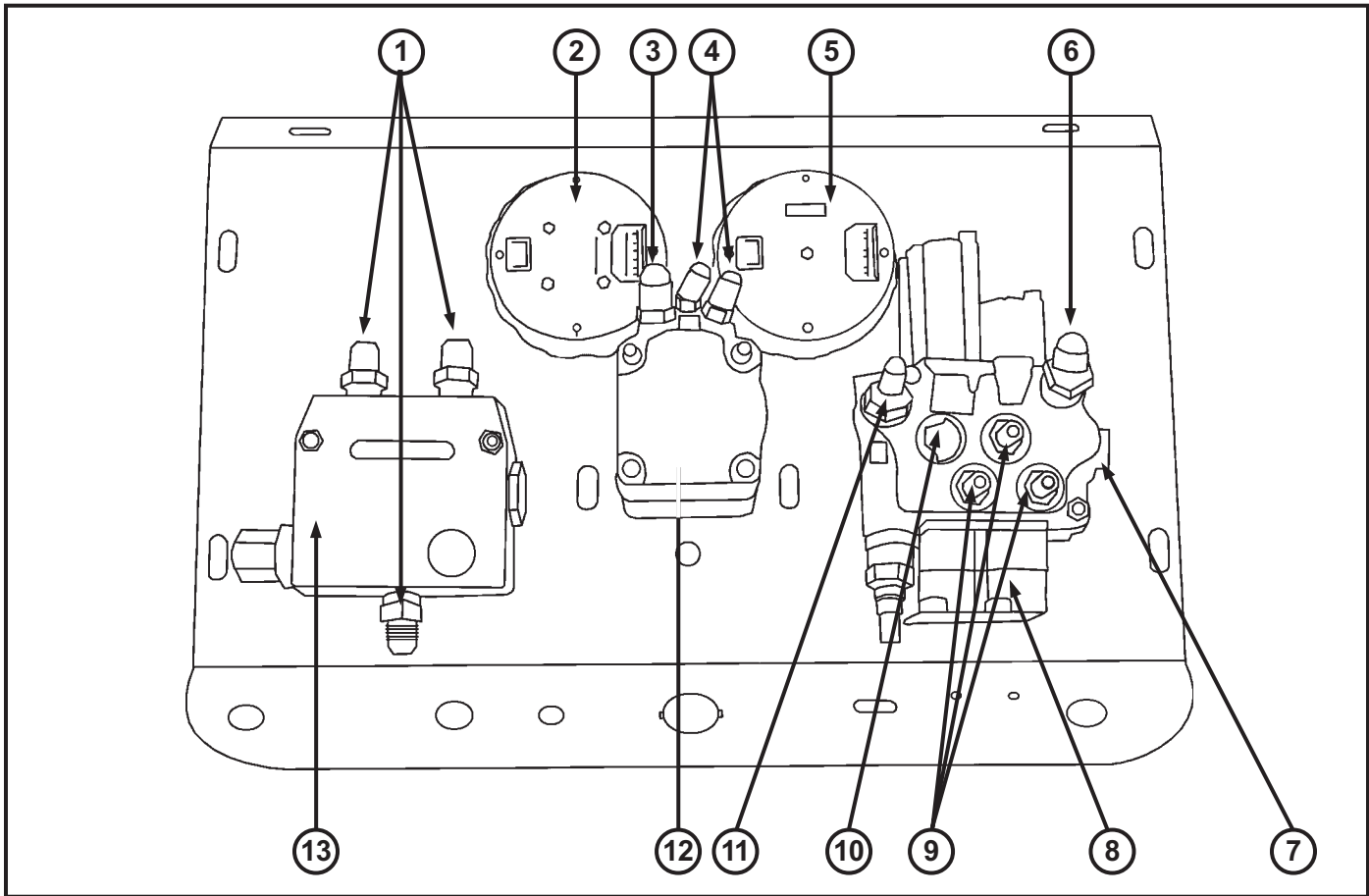

| ITEM | PART NUMBER | DESCRIPTION | QTY. |
|-------|-------------|--|------|
| 1 | 20123 | Fitting, #8MJIC x #8MP Straight, Sweeper | 3 |
| 2 | 38024 | Gauge, Fuel/Oil/Temp/Volts, Sweeper | 1 |
| 3 | 20142 | Fitting, #6 O-Ring x #8MJIC45°, (Forged), Sweeper | 1 |
| 4 | 20112 | Fitting, #6 O-Ring x #6MJIC45°, (Forged), Sweeper | 4 |
| 5 | 38043 | Gauge, Hourmeter/Tachometer Cluster, Sweeper | 1 |
| 6 | 20179 | Fitting, #8 O-Ring x #8JICM45°, Sweeper | 1 |
| 7 | 20167 | Fitting, Hex Head, #8 Plug, Sweeper | 1 |
| 8 | 38087 | Valve, Lift/Angle, Sweeper | 1 |
| 9 | 20111 | Fitting, #6 O-Rng x #6MJIC Straight, Sweeper | 3 |
| 10 | 20134 | Fitting, #6 O-Ring Plug, Sweeper | 1 |
| 11 | 20173 | Fitting, #8 O-Ring x #6JICM45°, Sweeper | 1 |
| 12 | 38537 | Gear, Steering, Sweeper | 1 |
| 13 | 38082 | Valve, Control, Variable, Broom RDRS-105-16, Sweeper | 1 |
| 2 & 5 | 72225 | New Gauge, Sweeper | 1 |

View from Back of Operator's Seat Left Side

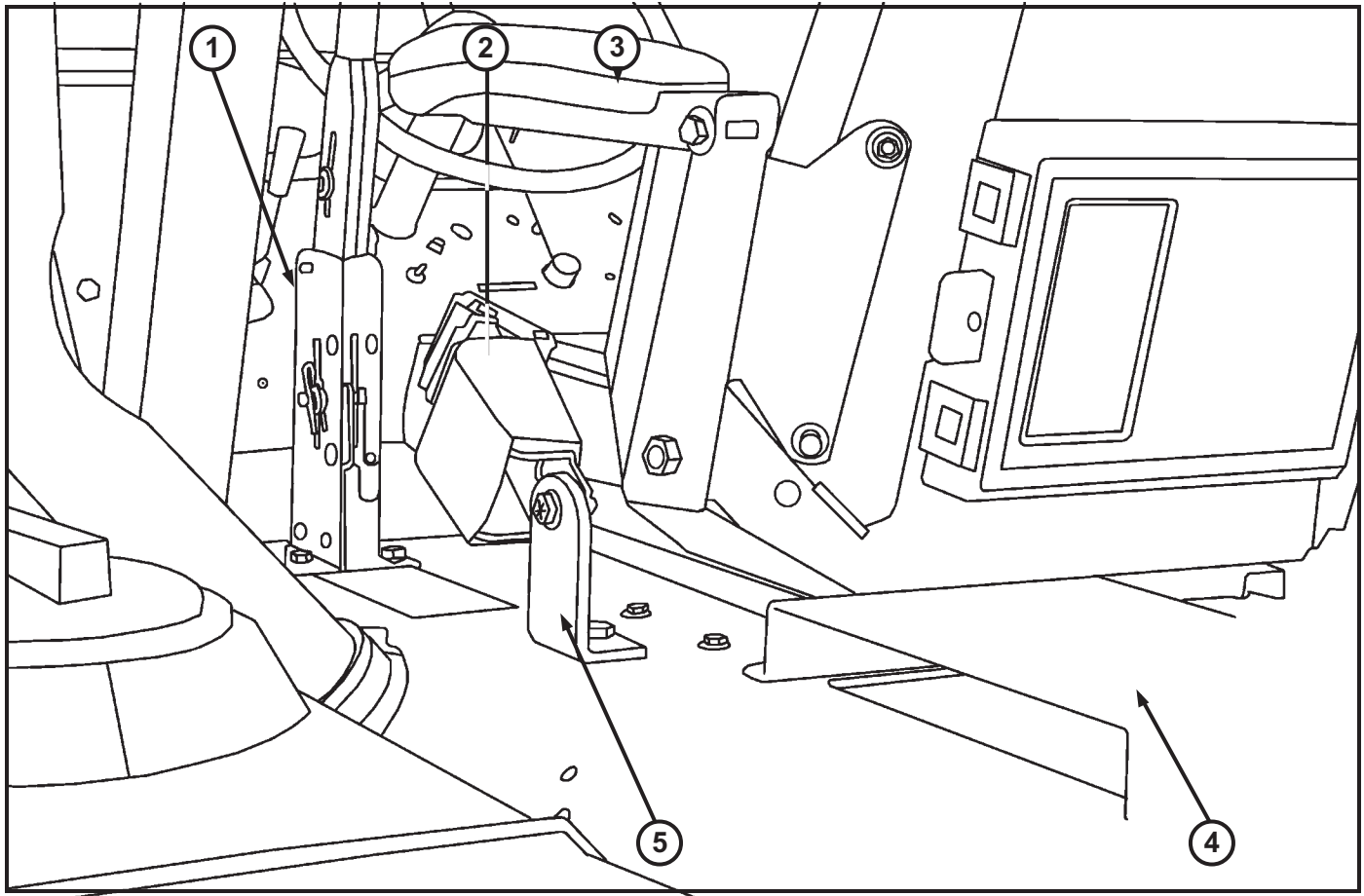

| ITEM | PART NUMBER | DESCRIPTION | QTY. |
|------|-------------|--|------|
| 1 | 38083 | Handle, Brake, Sweeper | 1 |
| 2 | 11903 | Belt, Seat, Sweeper/T5C/D/G/T7/T6/T9 | 2 |
| 3 | 11045 | Set, Arm Rest, Sweeper/T5/T5D/G/T7/T6/T9 | 1 |
| 4 | 38364 | Panel, Top, Engine, Sweeper | 1 |
| | 38362 | Deutz Kubota | |
| 5 | 38477 | Bracket, Seat Belt Mounting, Sweeper | 2 |

Parts

View from Inside Rear Panel

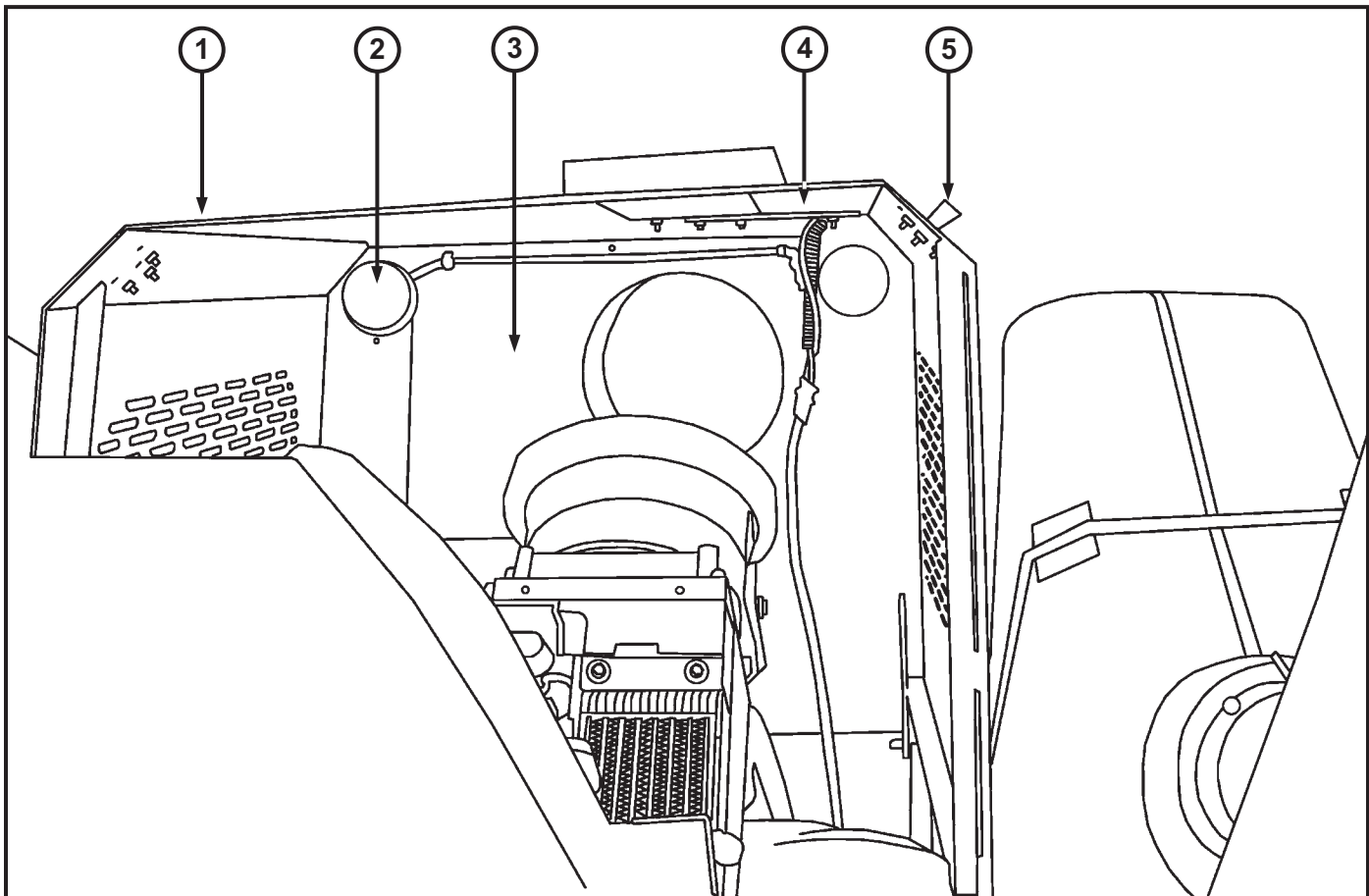

| ITEM | PART NUMBER | DESCRIPTION | QTY. |
|-----------|-------------|---|------|
| 1 | 38351 | Hood, Engine, Sweeper | 1 |
| 2 | 38084 | Light, Stop/Turn/Tail, Sweeper | 2 |
| 3 | 38363 | Panel, Cover, Rear, Engine, Sweeper | 1 |
| | 38361 | | |
| 4 | 38450 | Bracket, Tail Light Harness, Sweeper | 1 |
| 5 | 38143 | Latch, Engine Hood, Sweeper | 2 |
| NOT SHOWN | 70116 | Battery, T4/T5C/D/T6/T7/T9/Screed/Sweeper | 1 |
| | 77022 | | |
| NOT SHOWN | 38723 | Cable, Negative Battery, Sweeper | 1 |
| NOT SHOWN | 72001 | Cable, Ground Strap, 12" Eye x Eye, T6/T9/Sweeper | 1 |
| NOT SHOWN | 38722 | Cable, Positive Battery, Sweeper | 1 |
| NOT SHOWN | 38718 | Hold Down, Battery, Sweeper | 2 |
| NOT SHOWN | 38901 | Hood Assy. W/Lights | 1 |

View of Rear Engine Area

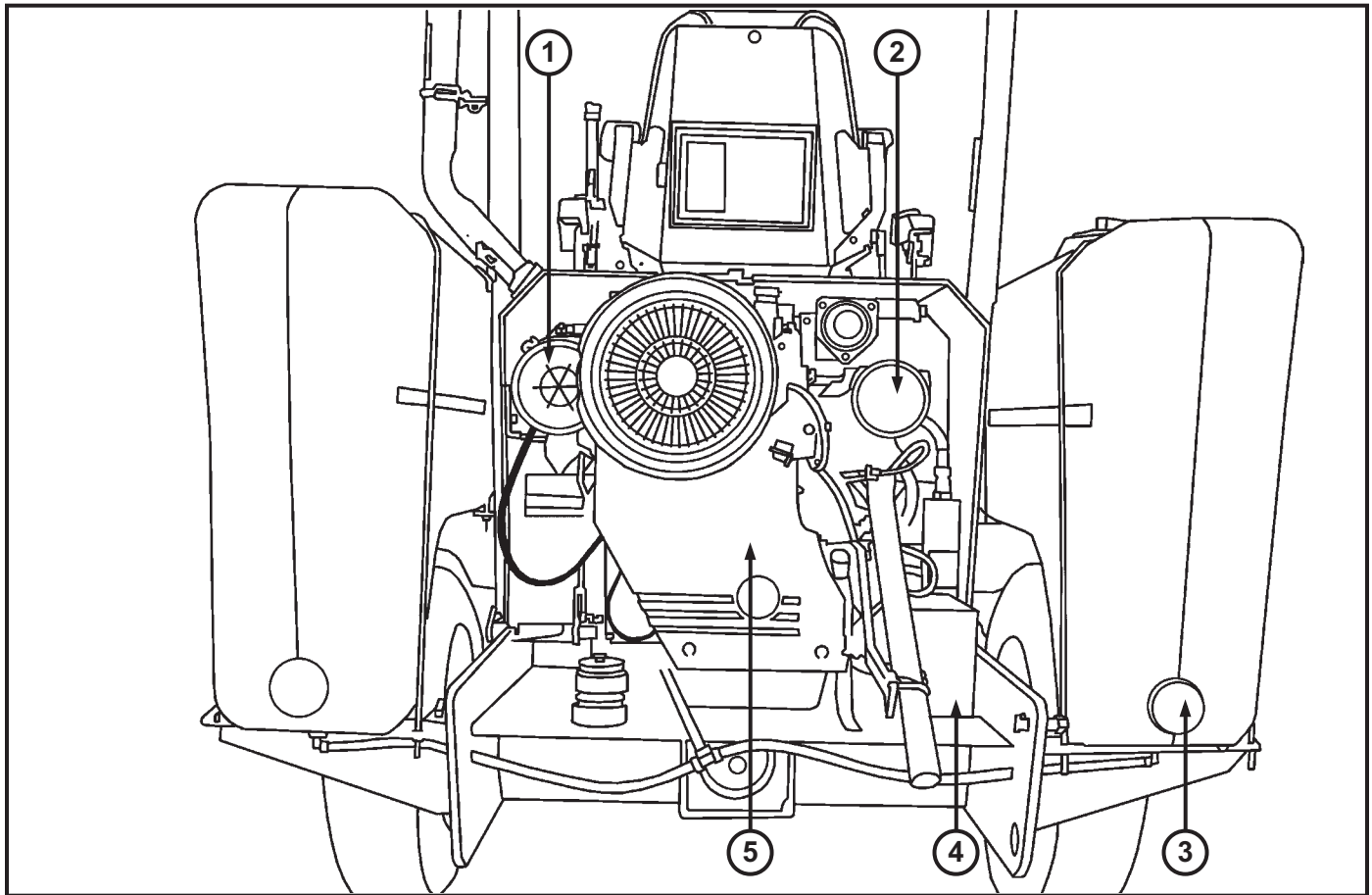

| ITEM | PART NUMBER | DESCRIPTION | QTY. | |
|------|-------------|----------------------------------|------|-----------------------|
| 1 | 38150 | Filter, Air, Sweeper | 1 | |
| | 38214 | | | Deutz |
| | 41072 | | | Kubota Kubota, New |
| 2 | 38170 | Muffler, Sweeper | 1 | |
| | 38728 | | | Deutz Kubota |
| 3 | 38580 | Plug, Drain, Water Tank, Sweeper | 2 | |
| 4 | 70116 | Battery, Sweeper | 1 | |
| | 77022 | | | Deutz Kubota |
| 5 | 38652 | Assembly, Engine, Sweeper | 1 | |
| | 38651 | | | Deutz Kubota |

Parts

Rear View of Transmission/Pump Assembly

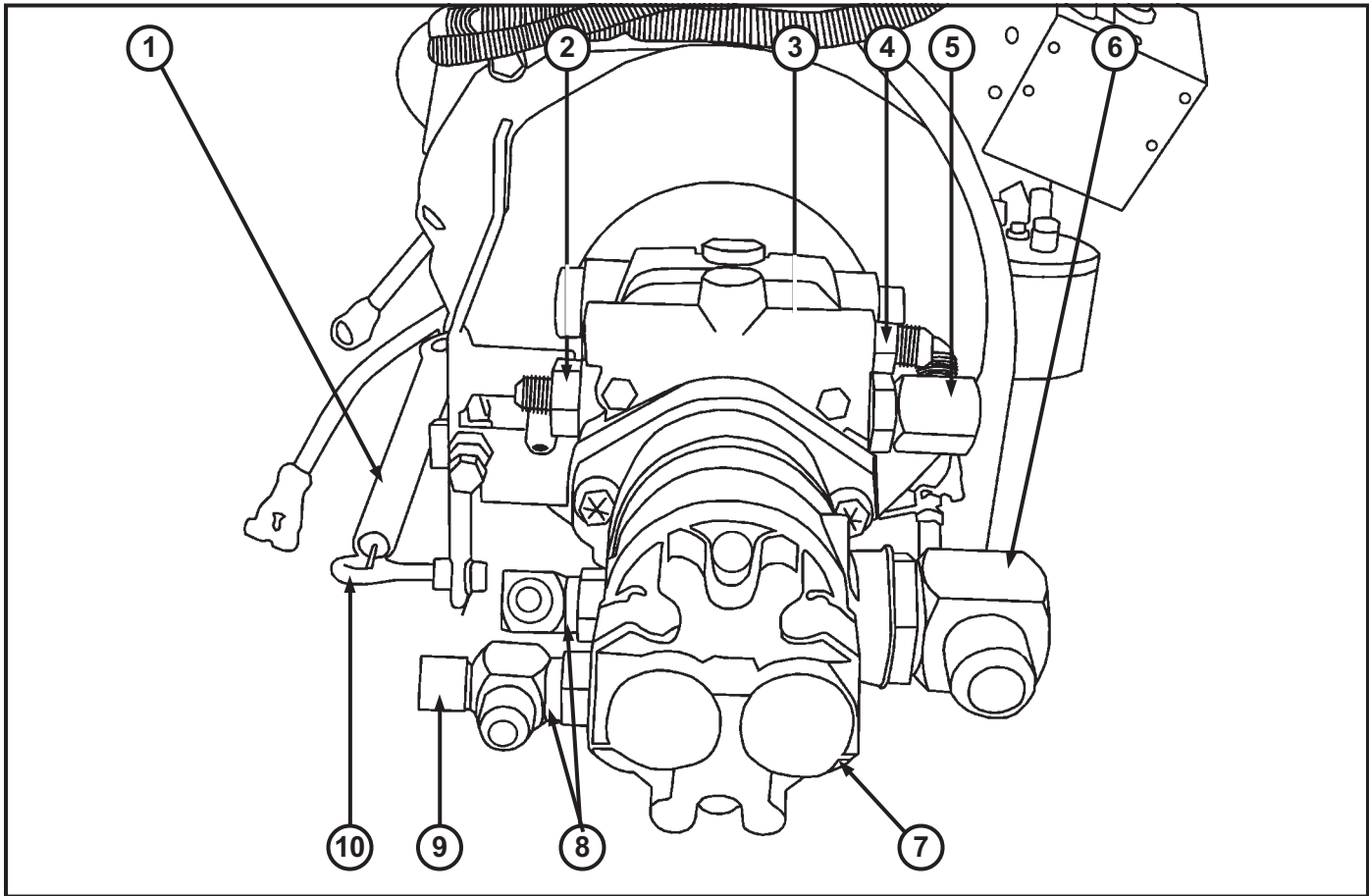

| ITEM | PART NUMBER | DESCRIPTION | QTY. |
|------|-------------|---|------|
| 1 | 39025 | Spring, Forward/Reverse Pedal, Sweeper | 1 |
| 2 | 20140 | Fitting, #12 O-Ring x #8MJIC, Sweeper | 1 |
| 3 | 38058 | Pump, Main Transmission, Sweeper | 1 |
| 4 | 20035 | Fitting, #8 O-Ring x #8MJIC, T5D/T7/T9/Sweeper | 1 |
| 5 | 20040 | Fitting, #12 O-Ring x #8MJIC90°, T6/T9/Sweeper | 1 |
| 6 | 20041 | Fitting, 1 1/4 O-Ring x 1" JIC90°, T6/T9/Sweeper | 1 |
| 7 | 38536 | Pump, Tandem, Eaton, Sweeper | 1 |
| 8 | 20124 | Fitting, #8MJIC x #10 O-Ring 90° w/Check P, Sweeper | 2 |
| 9 | 20116 | Fitting, "L" 1/4", Sweeper | 1 |
| 10 | 38513 | Bolt, Eye, 3/8 - 16 x 2", Sweeper | 2 |

Left Side View of Transmission/Pump Assembly

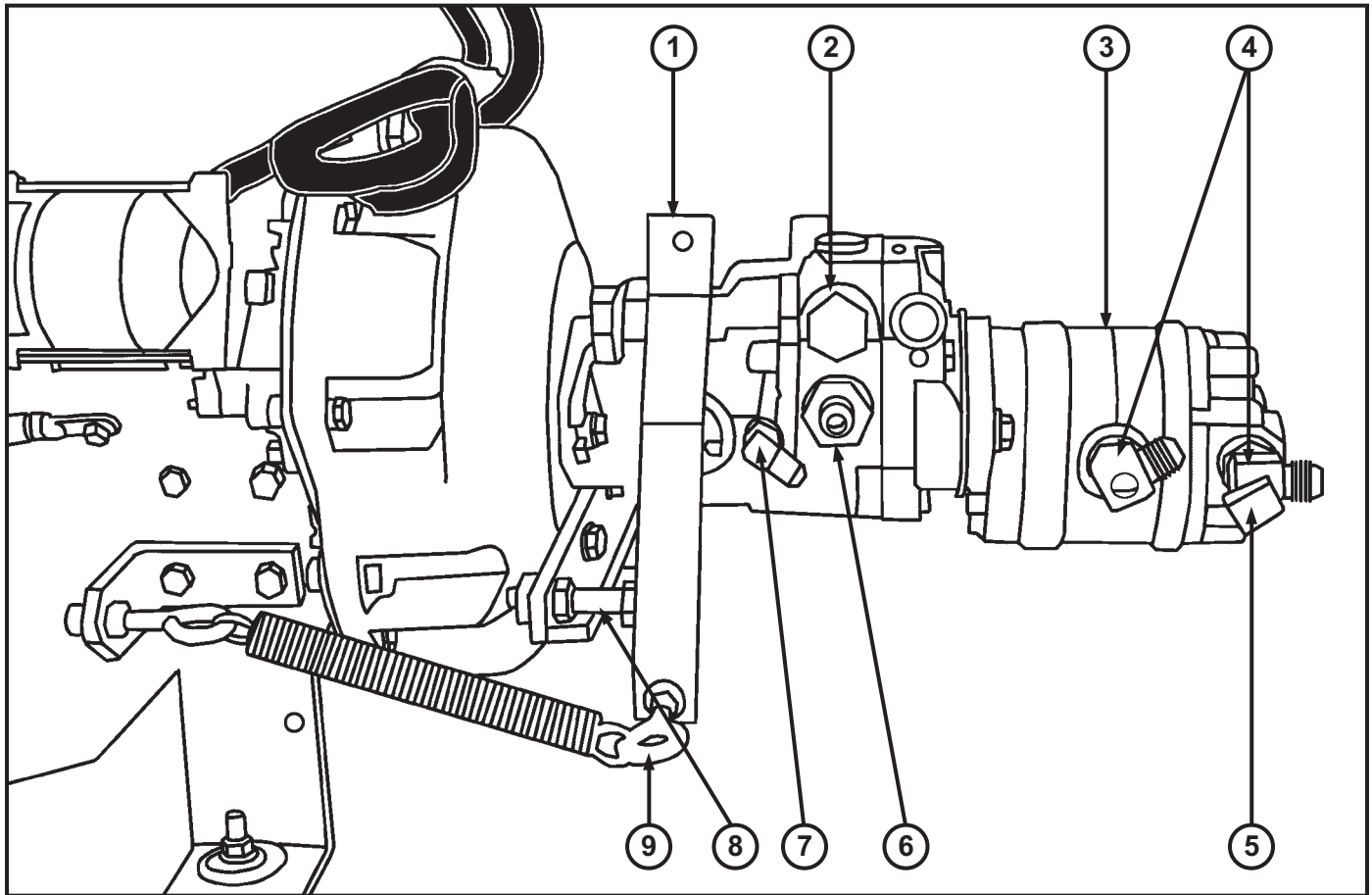

| ITEM | PART NUMBER | DESCRIPTION | QTY. |
|------|-------------|---|------|
| 1 | 38294 | Arm, Welded Pump, Sweeper | 1 |
| | 38611 | | |
| 2 | 38058 | Pump, Main Transmission, Sweeper | 1 |
| 3 | 38536 | Pump, Tandem, Eaton, Sweeper | 1 |
| 4 | 20124 | Fitting, #8MJIC x #10 O-Ring 90° w/Check P, Sweeper | 2 |
| 5 | 20116 | Fitting, "L" 1/4", Sweeper | 1 |
| 6 | 20140 | Fitting, #12 O-Ring x #8MJIC, Sweeper | 1 |
| 7 | 20144 | Fitting, #6 O-Ring x #6MJIC90°, Sweeper | 1 |
| 8 | 28022 | Bolt, 1/2 x 2 1/4" GR8, Sweeper | 1 |
| | 39025 | Assembly | 1 |

Parts

View of Under Seat Area

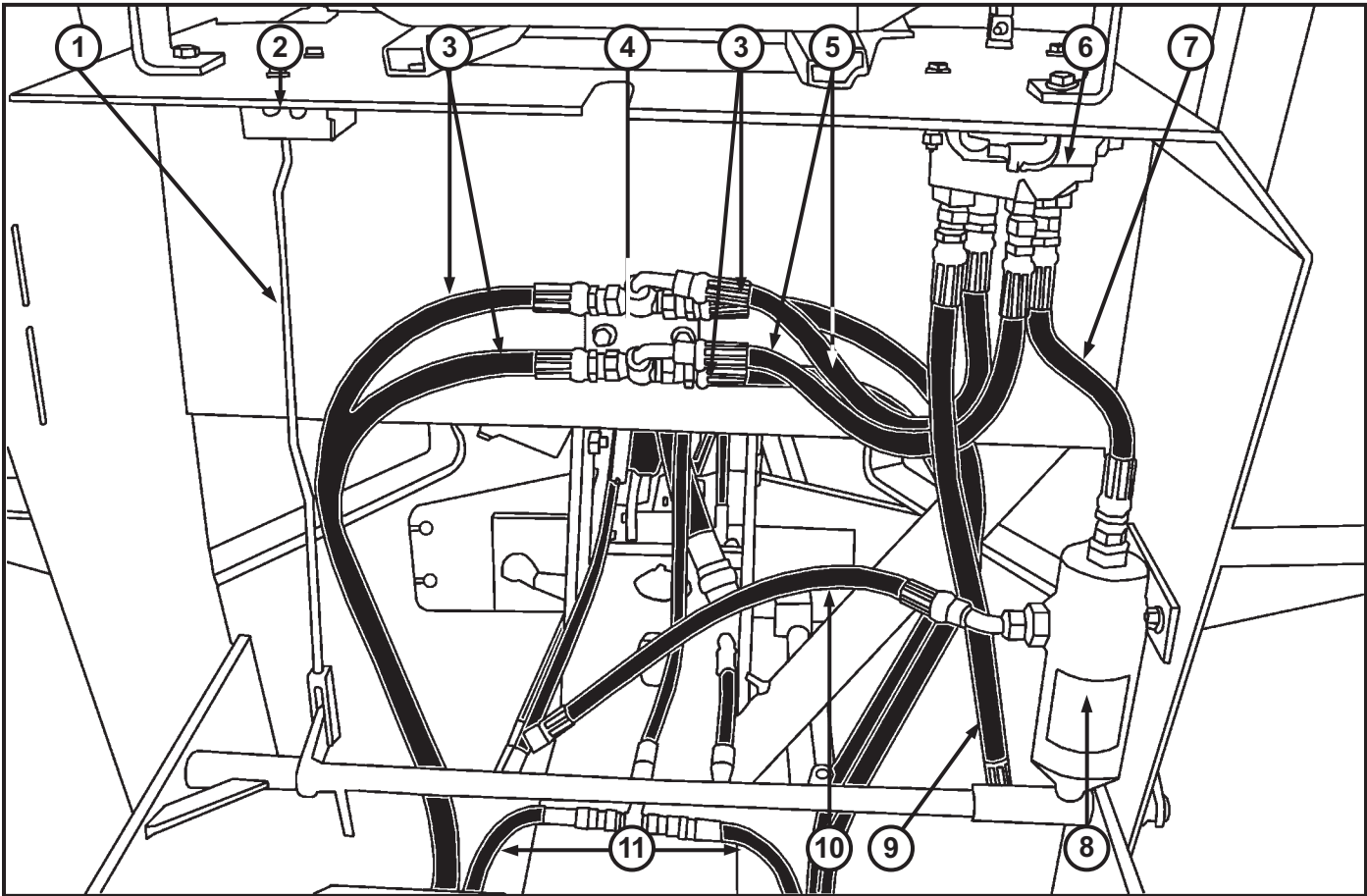

| ITEM | PART NUMBER | DESCRIPTION | QTY. |
|------|-------------|--|------|
| 1 | 38379 | Rod, Brake Lever, Plated, Sweeper | 1 |
| 2 | 77510 | Alarm, Back-Up, T5C/D/T6/T7/T9/Sweeper | 1 |
| 3 | 38097 | Hose, 1/2 x 36", #8FJIC x #8FJIC90°, Sweeper | 4 |
| 4 | 38343 | "T" Block, Sweeper | 1 |
| 5 | 38091 | Hose, 1/2 x 19 1/2", #8FJIC x #8FJIC90°, Sweeper | 2 |
| 6 | 38086 | Valve, Forward/Reverse, Sweeper | 1 |
| 7 | 38095 | Hose, 1/2 x 12", #8FMJICSTR Both, Sweeper | 1 |
| 8 | 38019 | Assembly, Filter, High Pressure, Sweeper | 1 |
| 9 | 38090 | Hose, 1/2 x 25", #8FMJIC Both, Sweeper | 1 |
| 10 | 38089 | Hose, 1/2 x 25", #8FJIC x #8FJIC45°, Sweeper | 1 |
| 11 | 38528 | Hose, 3/8 x 12", HY06-06FJ-06FJ9, Sweeper | 2 |

View of Lock Out

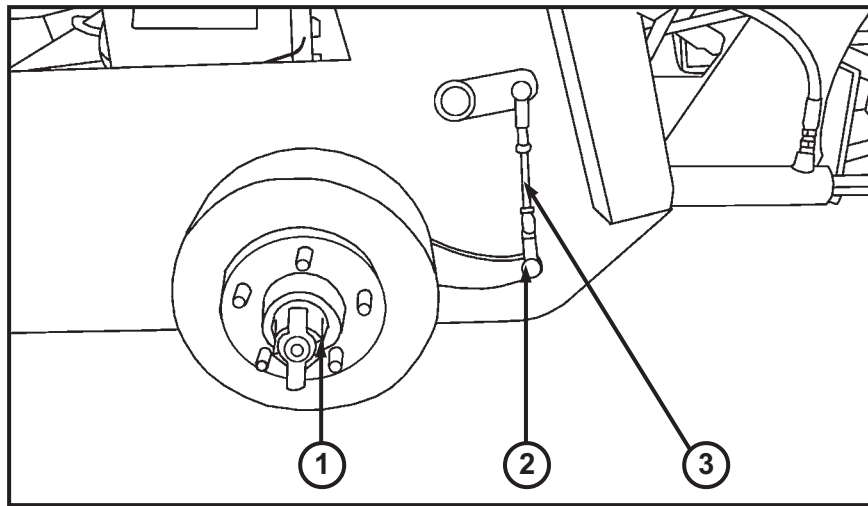

| ITEM | PART NUMBER | DESCRIPTION | QTY. |
|------|-------------|---|------|
| 1 | 38085 | Assembly, Brake/Disconnect, Sweeper | 2 |
| 2 | 38144 | Clevis, Weldable, 5/16 - 24, Screed/Sweeper | 2 |
| 3 | 38378 | Rod, Bellcrank Control, 4 ⁵ / ₈ "L, Sweeper | 1 |

Left Side Brush Assembly Breakdown

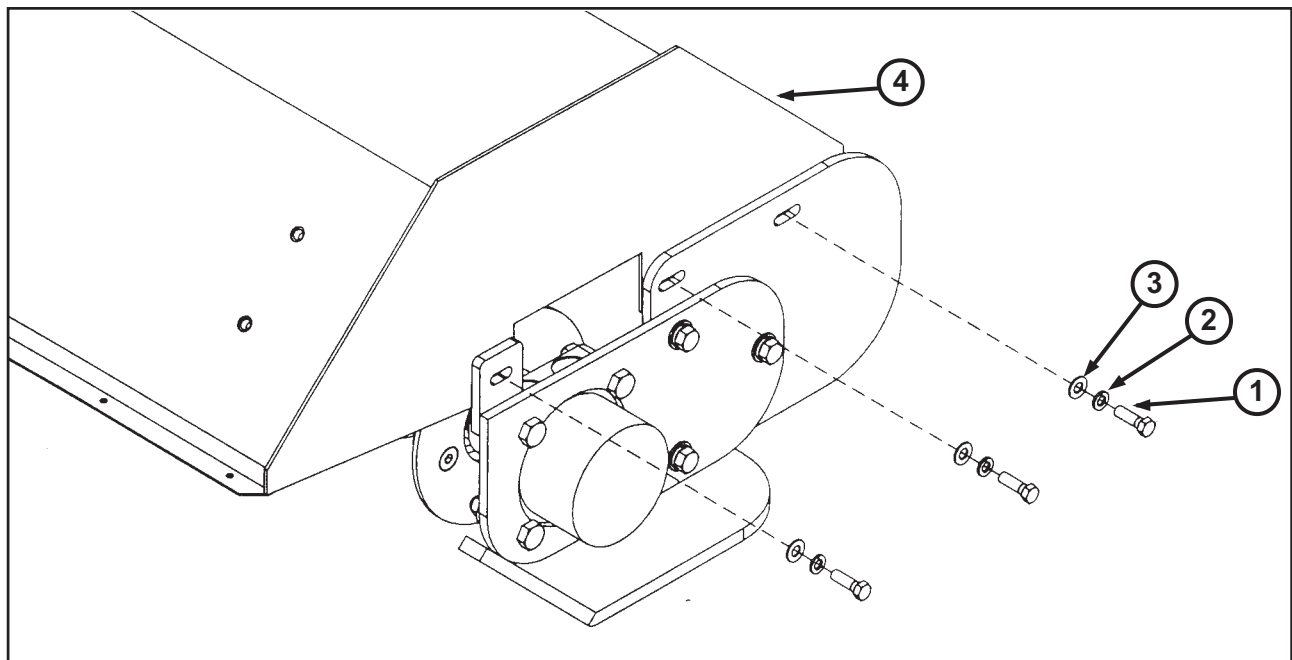

| ITEM | PART NUMBER | DESCRIPTION | QTY. |
|------|-------------|-------------------------|------|
| 1 | 22123 | 1/2" - 13 x 1 1/2" Bolt | 6 |
| 2 | 22171 | 1/2" Lock Washer | 6 |
| 3 | 28044 | 1/2" Flat Washer SAE | 6 |
| 4 | 38302 | 6' Brush Hood | 1 |
| | 38303 | 8' Brush Hood | 1 |

Parts

Front Fork Assy.

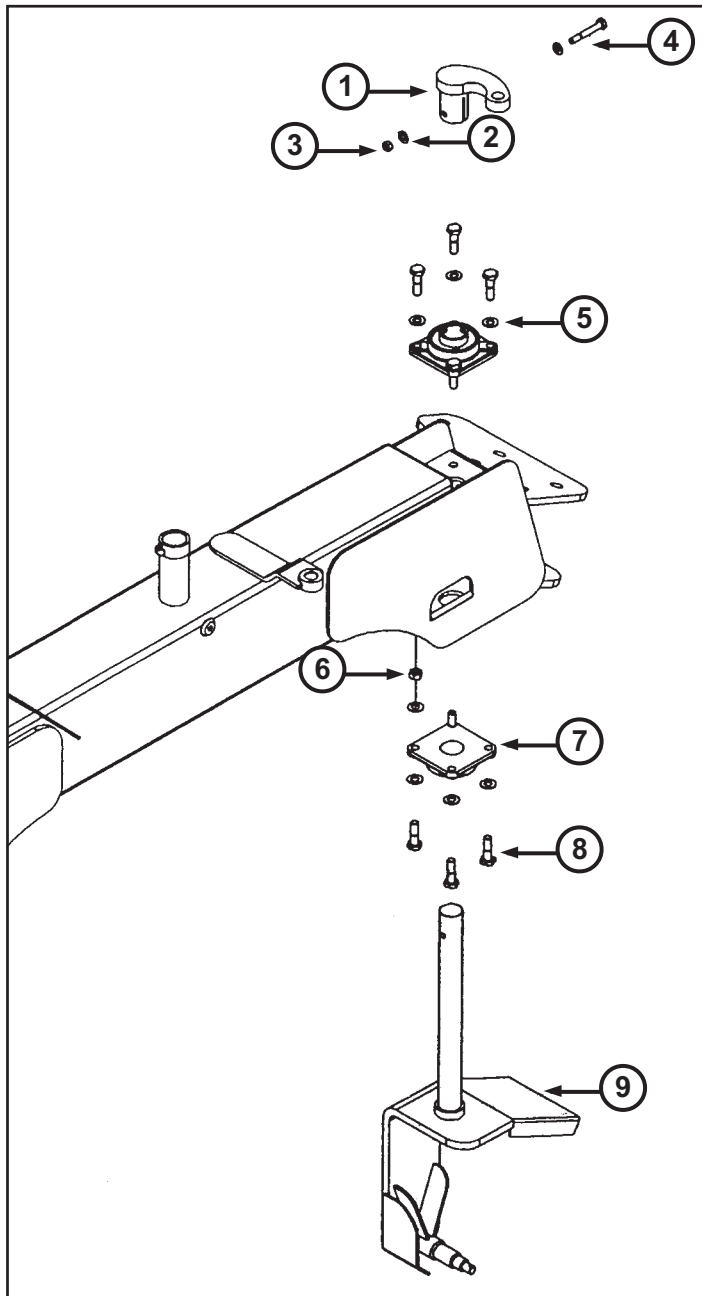

| ITEM | PART NUMBER | DESCRIPTION | QTY. |
|------|-------------|-----------------------|------|
| 1 | 38282 | Steering Arm | 1 |
| 2 | 28042 | 1/2 Washer | 1 |
| 3 | 23034 | 1/2 Lock Nut | 1 |
| 4 | 22158 | 1/2 Bolt | 1 |
| 5 | 28047 | 5/8 Washer | 16 |
| 6 | 22166 | 5/8 Lock Nut | 8 |
| 7 | 38169 | 4 Bolt Flange Bearing | 2 |
| 8 | 22160 | 5/8 Bolt | 8 |
| 9 | 38275 | Sweeper Front Fork | 1 |

Water System Routing

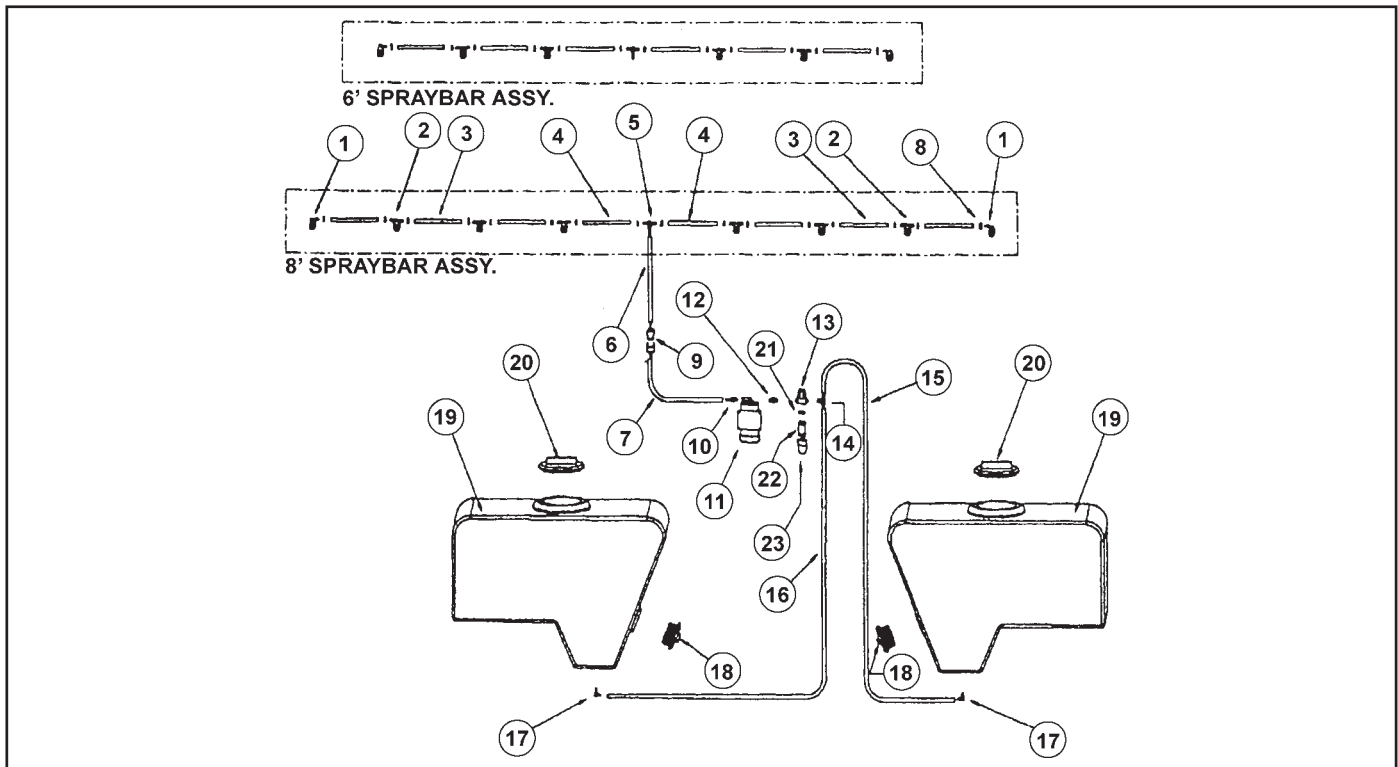

| ITEM | PART NUMBER | DESCRIPTION | 6' QTY. | 8' QTY. |
|------|-------------|----------------------------------|---------|---------|
| 1 | 38161 | 90 Degree Body | 2 | 2 |
| 2 | 38160 | "T" Body | 5 | 7 |
| 3 | 38152 | 3/8 Hose x 9" | 5 | 7 |
| 4 | 38153 | 3/8 Hose x 4" | 2 | 2 |
| 5 | 38163 | 3/8 Plastic "T" | 1 | 1 |
| 6 | 38154 | 3/8 Hose x 19" | 1 | 1 |
| 7 | 38155 | 3/8 Hose x 16" | 1 | 1 |
| 8 | 38176 | 3/8 Crimp Clamp | 22 | 24 |
| 9 | 38201 | Water Hose Connector | 1 | 1 |
| 10 | 38170 | 3/8 Mnpt x 90 Deg. x 3/8 Barb | 1 | 1 |
| 11 | 38168 | Water Pump | 1 | 1 |
| 12 | 38166 | 3/8 Mnpt x 1/2 Mnpt. Step Nipple | 1 | 1 |
| 13 | 38165 | Water Pump Filter | 1 | 1 |
| 14 | 38167 | 1/2 Mnpt. x 3/8 Barb | 1 | 1 |
| 15 | 38202 | 3/8" Hose (Right) x 75" | 1 | 1 |
| 16 | 38203 | 3/8" Hose (Left) x 65" | 1 | 1 |
| 17 | 38170 | 3/8" Mnpt. x 90 Deg. x 3/8 Barb | 2 | 2 |
| 18 | 38204 | Water Tank Drain Plug | 2 | 2 |
| 19 | 38390 | Water Tanks | 2 | 2 |
| 20 | 38205 | Water Tank Cap | 2 | 2 |
| 21 | | Filter "O" Ring (Spare Parts) | 1 | 1 |
| 22 | | Filter Element (Spare Parts) | 1 | 1 |
| 23 | | Filter Bowl (Spare Parts) | 1 | 1 |

Parts

Sprayer Parts

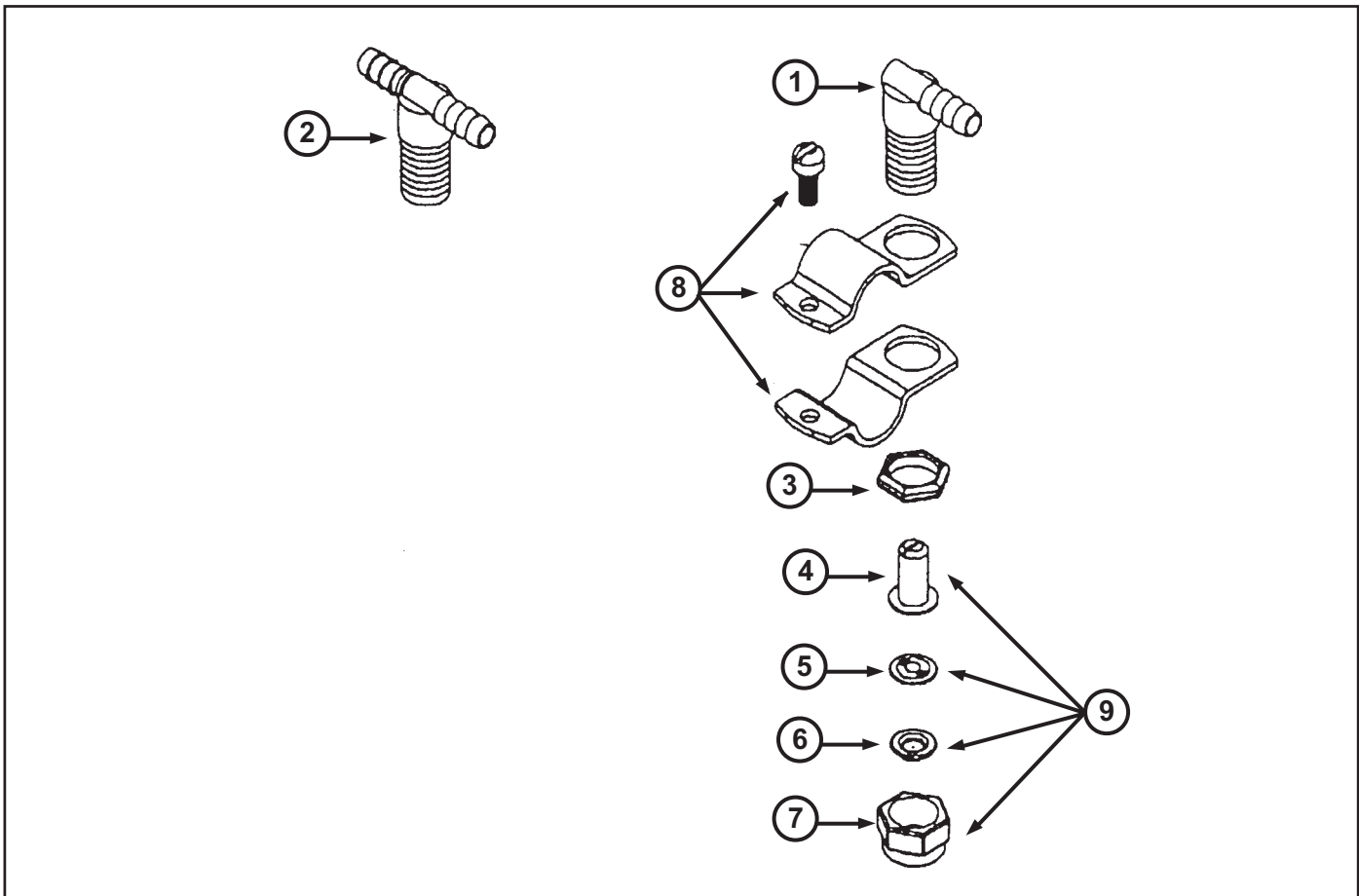

| ITEM | PART NUMBER | DESCRIPTION | 6' QTY. | 8' QTY. |
|------|-------------|----------------------------------|---------|---------|
| 1 | 38161 | 90° Degree Water Fitting | 2 | 2 |
| 2 | 38160 | Tee Brass Water Fitting | 4 | 6 |
| 3 | | Nut, Comes on Part 38160 & 38161 | 6 | 8 |
| 4 | 38159 | Check Valve Strainer | 6 | 8 |
| 5 | 38164 | Brass Seal | 6 | 8 |
| 6 | 38158 | Water Spray Orifice | 6 | 8 |
| 7 | 38157 | Brass Cap | 6 | 8 |
| 8 | 38162 | Spray Bar Clamp W/Screw | 6 | 8 |
| 9 | 38908 | Spray Kit Items 4,5,6,7 | 6 | 8 |

Brush Core

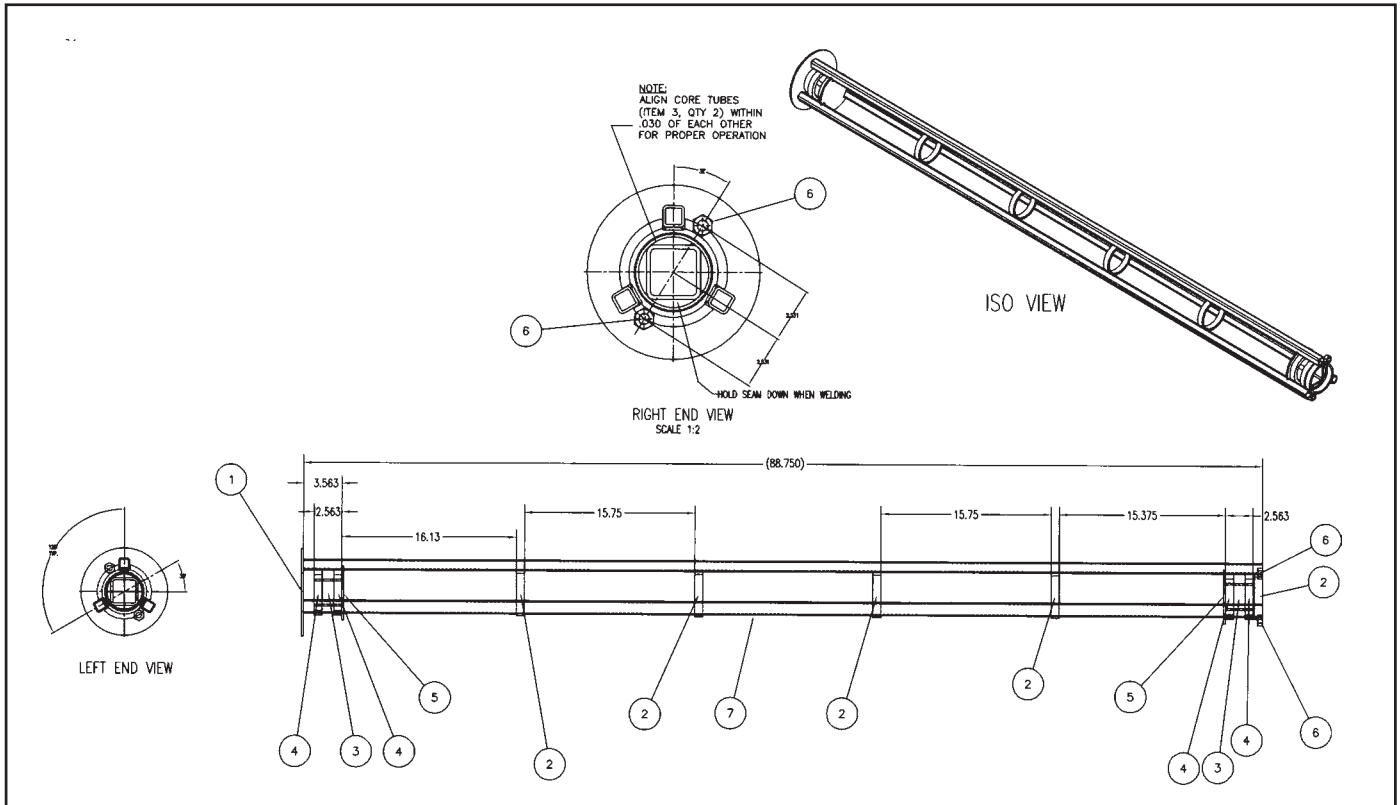

| ITEM | PART NUMBER | DESCRIPTION | QTY. |
|------|-------------|-------------------------------|------|
| 1 | 38330 | Plate, Broom Core End | 2 |
| 2 | 38327 | Rings, Thin Broom Core Center | 5 |
| 3 | 38603 | Tube - Broom Core | 5 |
| 4 | 38326 | Rings, Thick Broom Core | 2 |
| 5 | 38672 | Plate - Broom Core Cap | 1 |
| 6 | 38620 | Nut - 1/2 - 13 Heavy Hex | 1 |
| 7 | 38324 | Tube, Broom, Core, 8' | 1 |

Parts

Front Hub

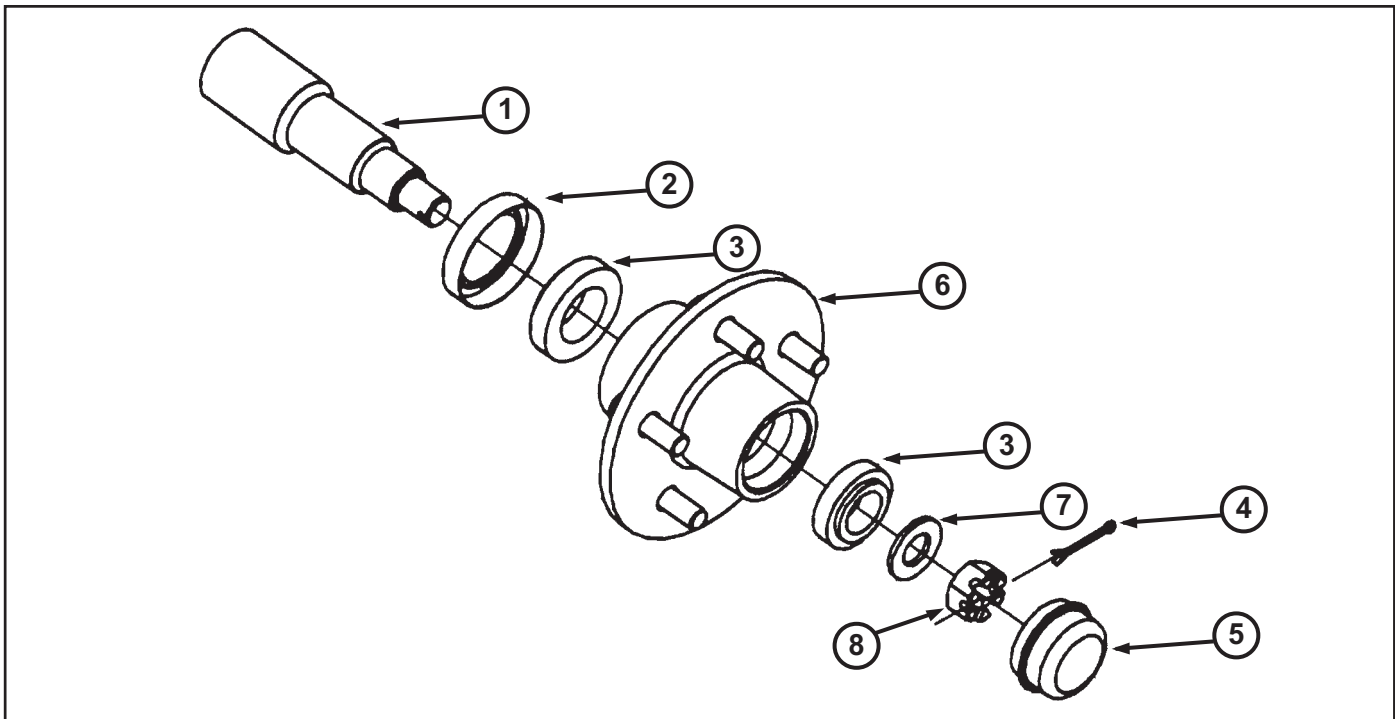

Old, Prior To Ser#23TS0327

| ITEM | PART NUMBER | DESCRIPTION | QTY. |
|------|-------------|--|------|
| 1 | 38141 | Spindle, P/N | 1 |
| 2 | 38914 | Rings, Thin Broom Core Center - Seal Sold Separately | 1 |
| 3 | 38484 | Bearing/Race FR Hub | 2 |
| 4 | 53160 | Cotter Pin 1/8" x 1 3/4" | 1 |
| 5 | 38485 | Dust Cap | 1 |
| 6 | | Hub, Not Sold Separately | 1 |
| 7 | 28015 | Washer, P/N, 1" SAE | 1 |
| 8 | 28016 | Slotted Nut, P/N, 1" - 14 | 1 |
| 9 | 38047 | Kit P/N Contains Bearings, Hub and Dust Cap | 1 |

New, After Ser#23TS0327

| ITEM | PART NUMBER | DESCRIPTION | QTY. |
|------|-------------|---|------|
| 1 | 38850 | Spindle, P/N | 1 |
| 2 | 38863 | Seal | 1 |
| 3 | 53123 | Bearing, FR Inner | 1 |
| 4 | 53125 | Bearing, FR Outer | 1 |
| 5 | 53160 | Cotter Pin 1/8" x 1 3/4" | 1 |
| 6 | 53170 | Dust Cap | 1 |
| 7 | 53137 | Hub | 1 |
| 8 | 53140 | Washer, P 3/4" SAE | 1 |
| 9 | 53150 | Slotted Nut, P/N 3/4" | 1 |
| 10 | 38864 | Kit P/N Contains Bearings, Hub and Dust Cap | 1 |

Pivot Bearing Weldment Assembly

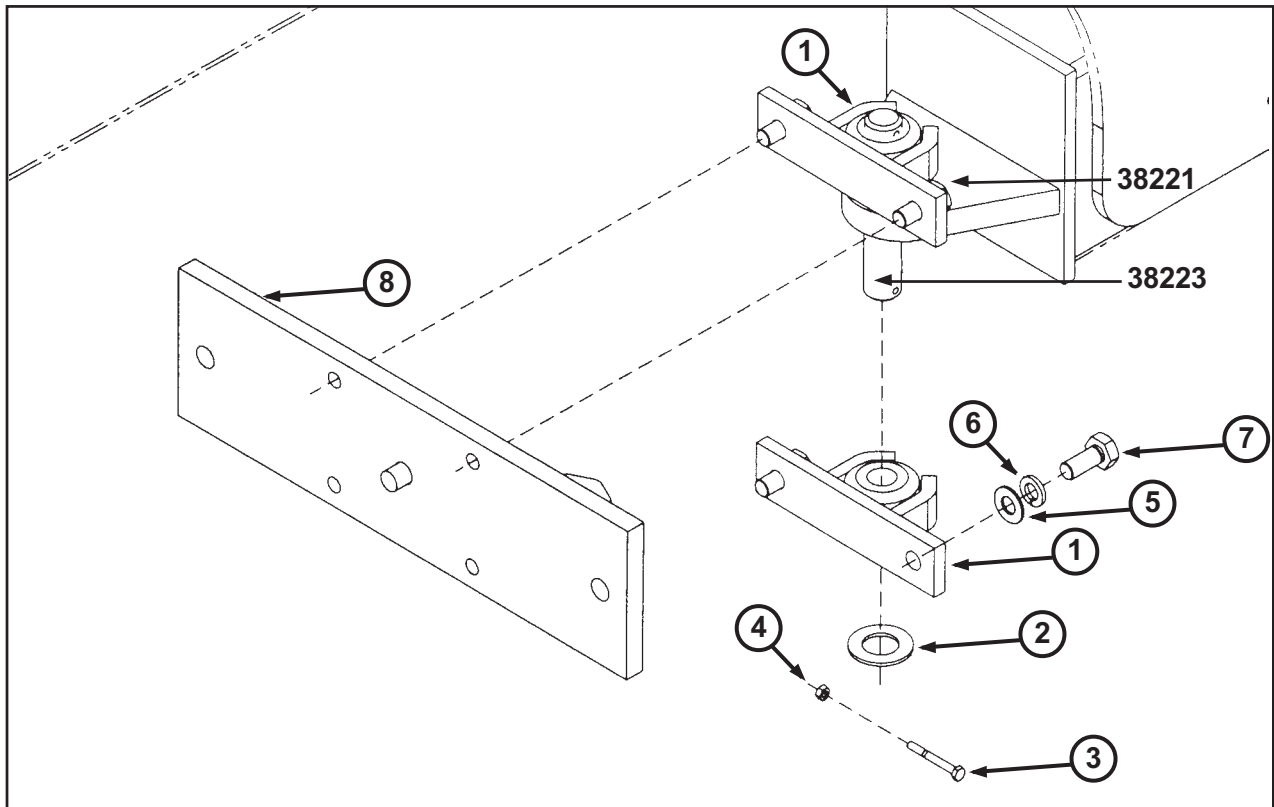

| ITEM | PART NUMBER | DESCRIPTION | QTY. |
|------|-------------|-------------------------|------|
| 1 | 38314 | Pivot Bearing Weldment | 2 |
| 2 | 22175 | 1 1/4" Washer | 1 |
| 3 | 22150 | 1/4" - 20 x 2 1/4" Bolt | 1 |
| 4 | 22171 | 1/4" Lock Nut | 1 |
| 5 | 28047 | 5/8" Flat Washer | 4 |
| 6 | 22162 | 5/8" Lock Washer | 4 |
| 7 | 22214 | 5/8" - 18 x 1 1/2" Bolt | 4 |
| 8 | 38346 | Pivot Bracket Weldment | 1 |

Parts

Broom Mount Weldment

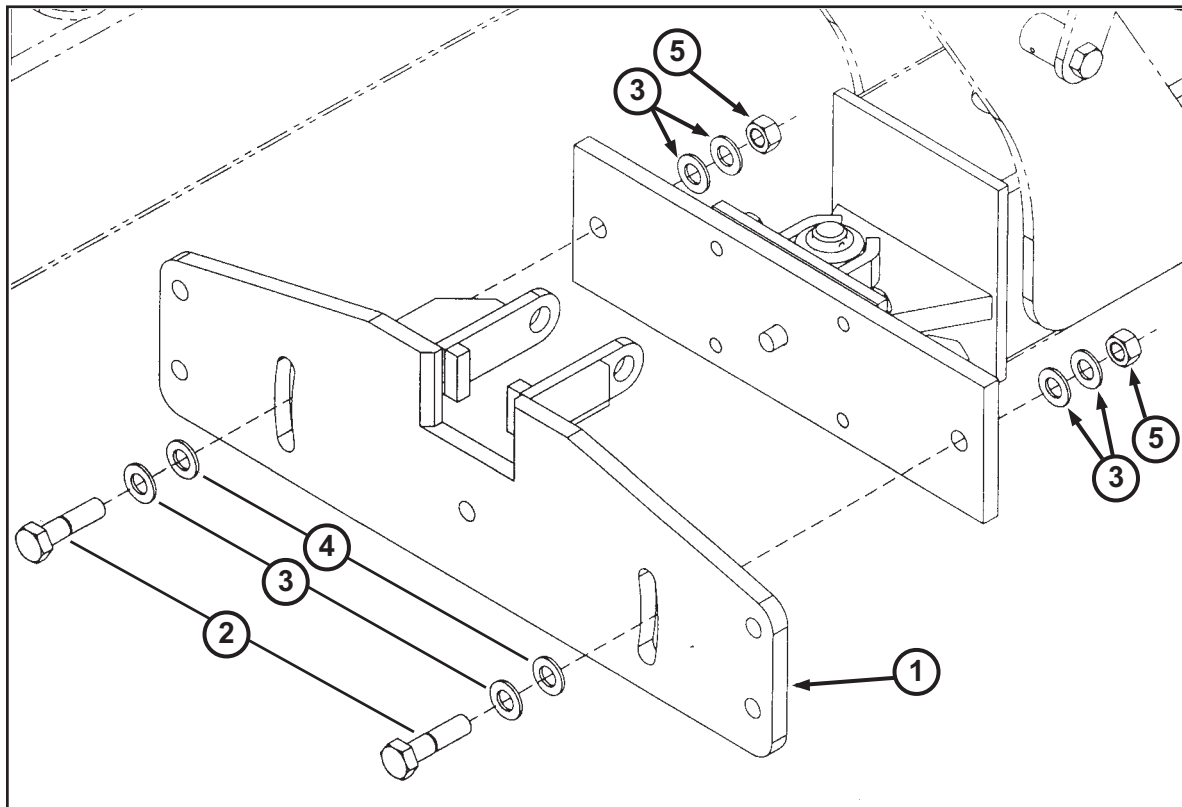

| ITEM | PART NUMBER | DESCRIPTION | QTY. |
|------|-------------|---------------------------|------|
| 1 | 38313 | Broom Mount Plate W/Stops | 1 |
| 2 | 28030 | 3/4" - 10 x 3" Bolt | 2 |
| 3 | 53140 | 3/4" Flat Washer SAE | 6 |
| 4 | 28060 | 3/4" Flat Washer USS | 2 |
| 5 | 28037 | 3/4" Lock Nut | 2 |

Brush Bar Assembly

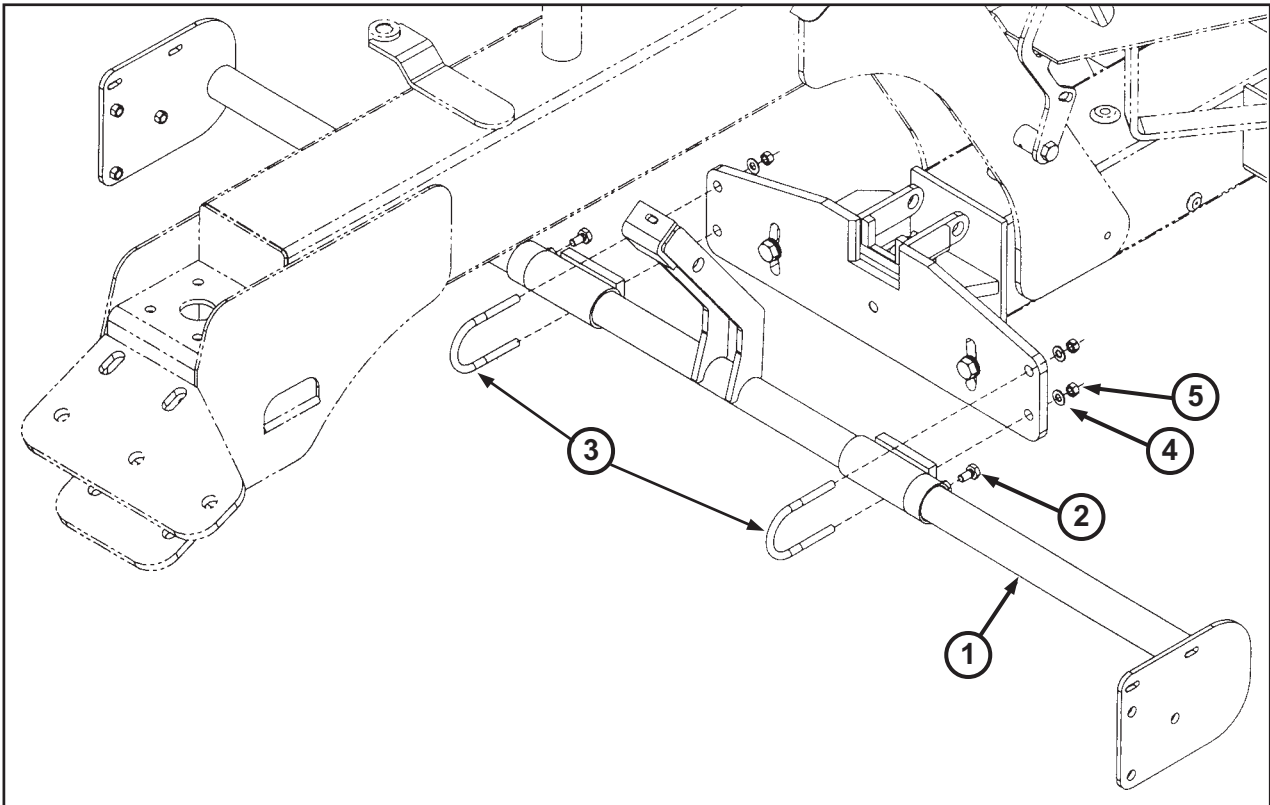

| ITEM | PART NUMBER | DESCRIPTION | QTY. |
|------|-------------|-----------------------|------|
| 1 | 38306 | 6' Brush Mount Bar | 1 |
| | 38307 | 8' Brush Mount Bar | 1 |
| 2 | 28019 | 1/2" - 13 x 1" Bolt | 2 |
| 3 | 22168 | 1/2" x 3" x 6" U-Bolt | 2 |
| 4 | 28042 | 1/2" Flat Washer SAE | 4 |
| 5 | 28059 | 1/2" - 20 Lock Nut | 4 |

Parts

Brush Bar Cylinder

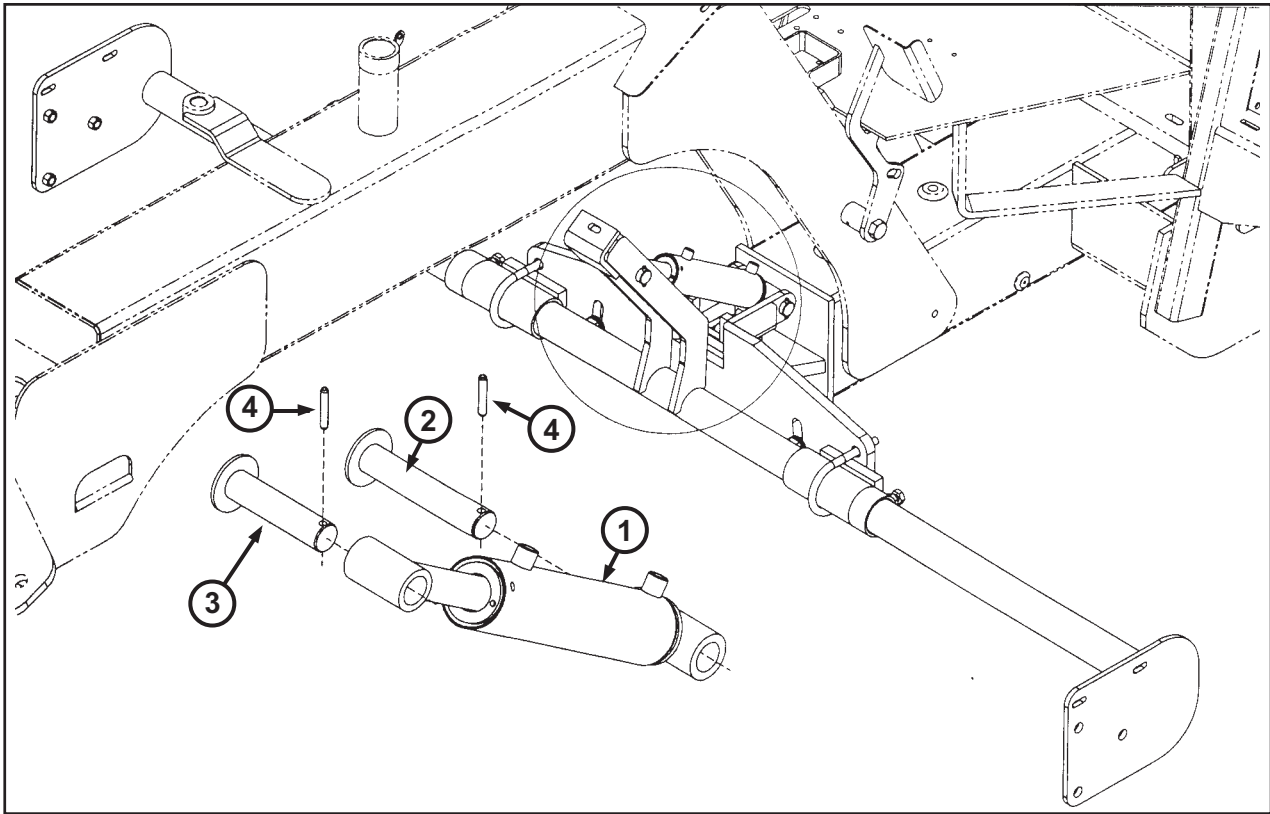

| ITEM | PART NUMBER | DESCRIPTION | QTY. |
|------|-------------|-----------------------------|------|
| 1 | 38016 | Brush Lift Cylinder | 1 |
| 2 | 38421 | 1" Dia. x 5 1/8 Long Pin | 1 |
| 3 | 38422 | 1" Dia. x 4 1/8" Long Pin | 1 |
| 4 | 28042 | 1/4" x 1 1/2" Long Roll Pin | 2 |

Brush Core Motor Mount

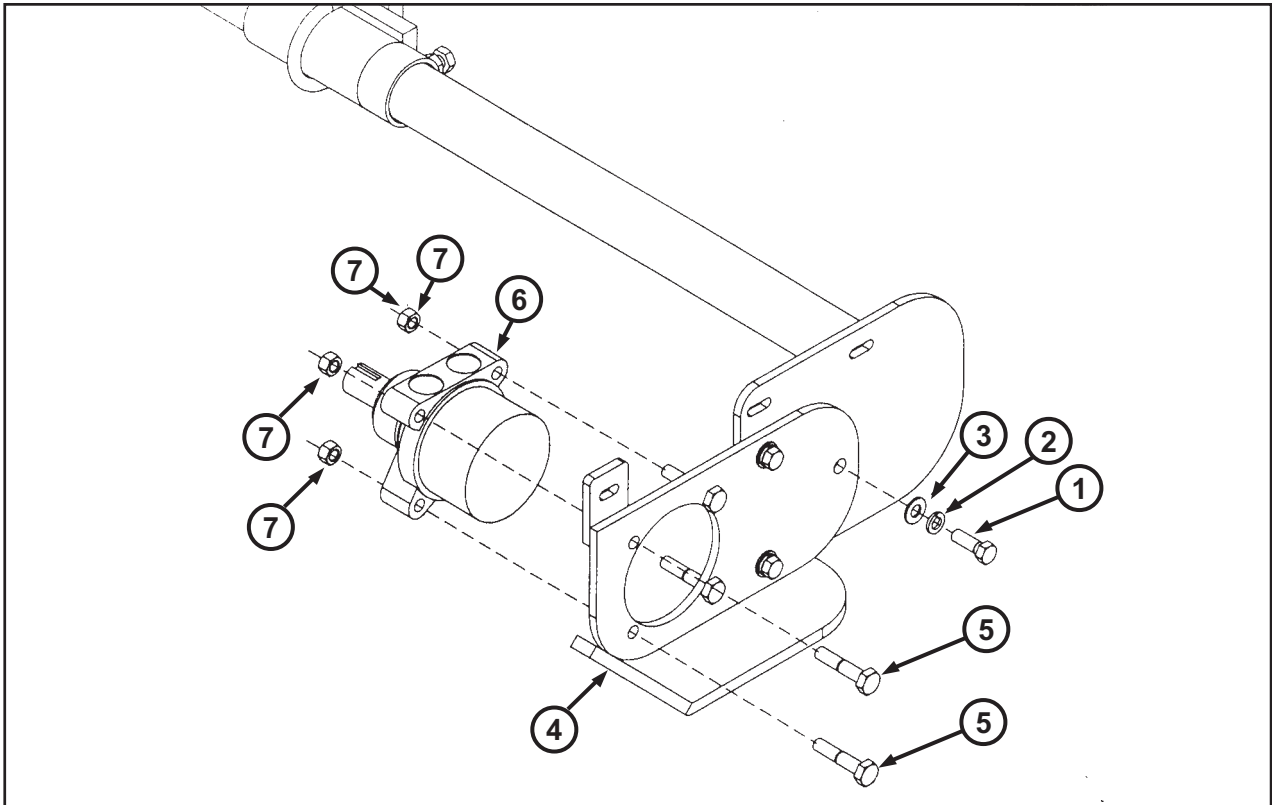

| ITEM | PART NUMBER | DESCRIPTION | QTY. |
|------|-------------|----------------------------|------|
| 1 | 22037 | 1/2" - 13 x 1 1/2" Bolt | 6 |
| 2 | 24013 | 1/2" Lock Washer | 6 |
| 3 | 28042 | 1/2" Flat Washer SAE | 6 |
| 4 | 38402 | Brush Core Motor Mount, LH | 1 |
| | 38403 | Brush Core Motor Mount, RH | 1 |
| 5 | 22146 | 1/2" - 13 x 2 1/2" Bolt | 8 |
| 6 | 38052 | Brush Core Motor | 2 |
| 7 | 28500 | 1/2" Lock Nut | 8 |

Parts

Brush Core Plate & Block For Motor Assembly

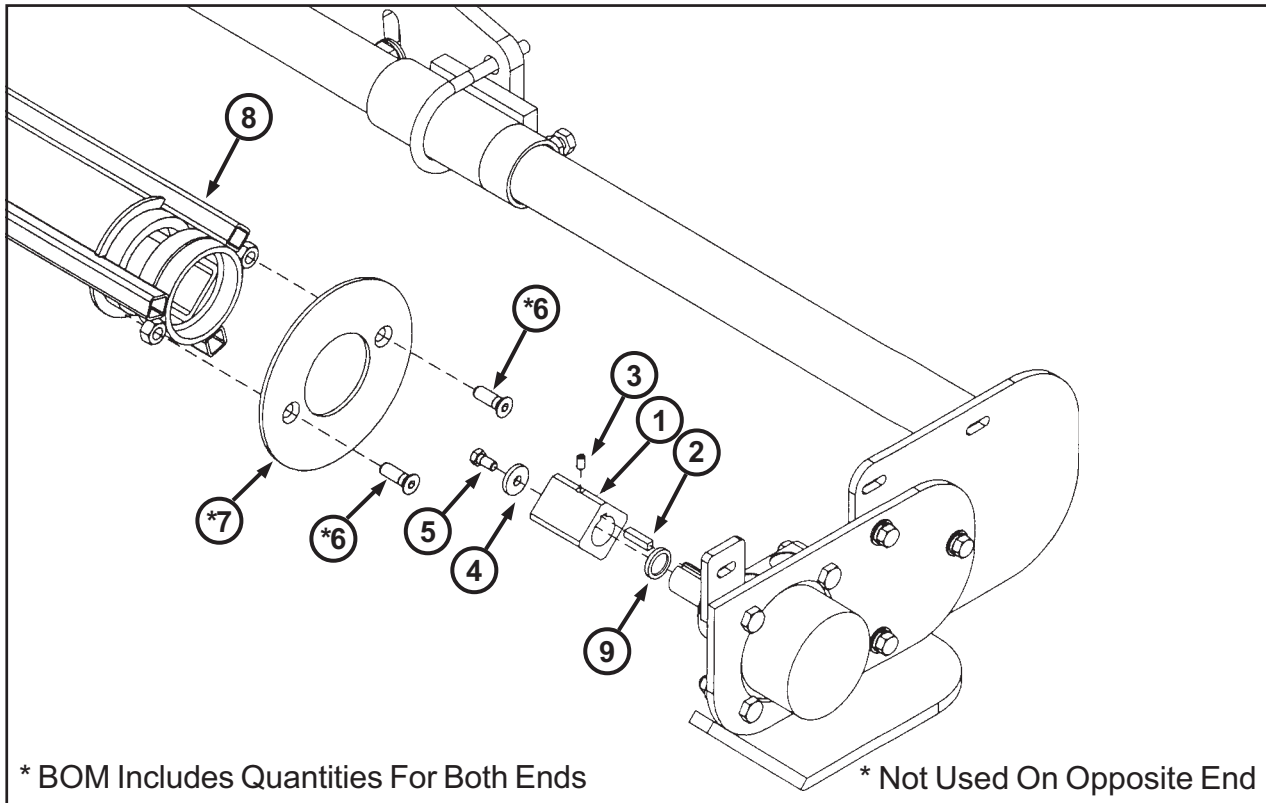

| ITEM | PART NUMBER | DESCRIPTION | QTY. |
|------|-------------|------------------------------|------|
| 1 | 38315 | Drive Motor Block | 2 |
| 2 | 38809 | Straight Key | 2 |
| 3 | 22115 | 5/16" - 18 x 1/2" Set Screw | 2 |
| 4 | 38428 | Key Retainer Washer | 2 |
| 5 | 22044 | 3/8" x 3/4" Bolt | 2 |
| 6 | 22167 | 1/2" x 1 1/4" Flat Head Bolt | 2 |
| 7 | 38329 | Brush Core Cap Plate | 1 |
| 8 | 38308 | 6' Brush Core | 1 |
| | 38309 | 8' Brush Core | 1 |
| 9 | 38432 | Block Seal for Brush Motor | 1 |

Spray Bar Assembly

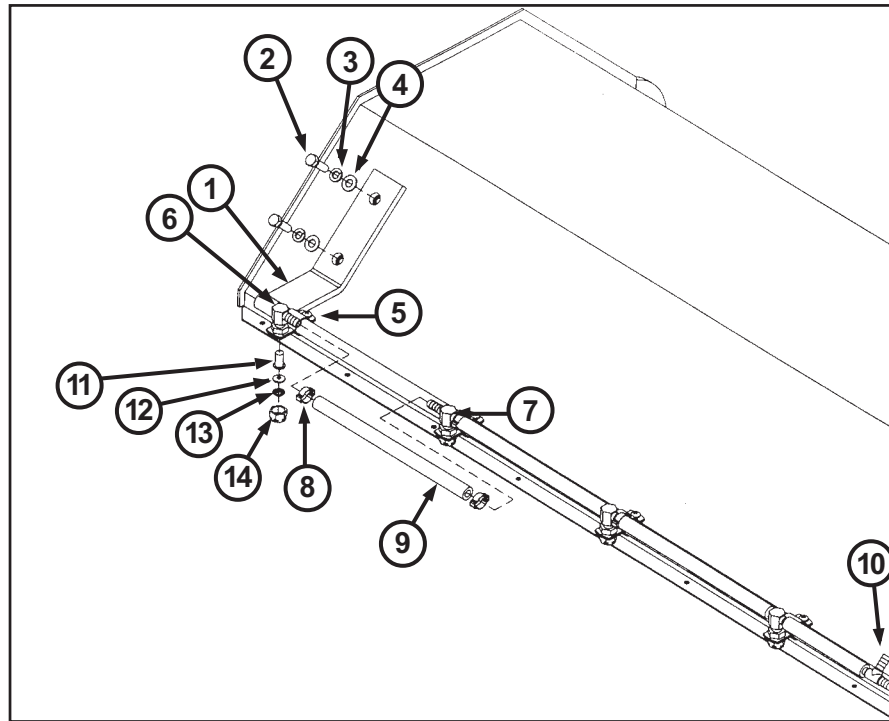

| ITEM | PART NUMBER | DESCRIPTION | QTY. |
|------|-------------|---|-------|
| 1 | 38304 | 6' Spray Bar | 1 |
| | 38305 | 8' Spray Bar | 1 |
| 2 | 22123 | 3/8" - 16 x 1 1/4" Bolt, Zinc Plated | 4 |
| 3 | 22171 | 3/8" Lock Washer | 4 |
| 4 | 28044 | 3/8" Flat Washer | 4 |
| 5 | 38162 | Spray Bar Clamp W/Screw | 8 |
| 6 | 38161 | 90° Brass Water Fitting | 2 |
| 7 | 38160 | Tee Brass Water Fitting | 6 |
| 8 | 38176 | Spray Hose Clamp | 16 |
| 9 | 38387 | 3/8" Spray Hose (6 - 10 1/2", 2 - 4 1/2") | 6 ft. |
| 10 | 20135 | 3/8" Barbed Tee Water Fitting | 1 |
| 11 | 38159 | Check Valve Strainer | 8 |
| 12 | 38164 | Brass Seal | 8 |
| 13 | 38158 | Water Spray Orifice | 8 |
| 14 | 38157 | Brass Cap | 8 |

Parts

Brake Hub Assembly

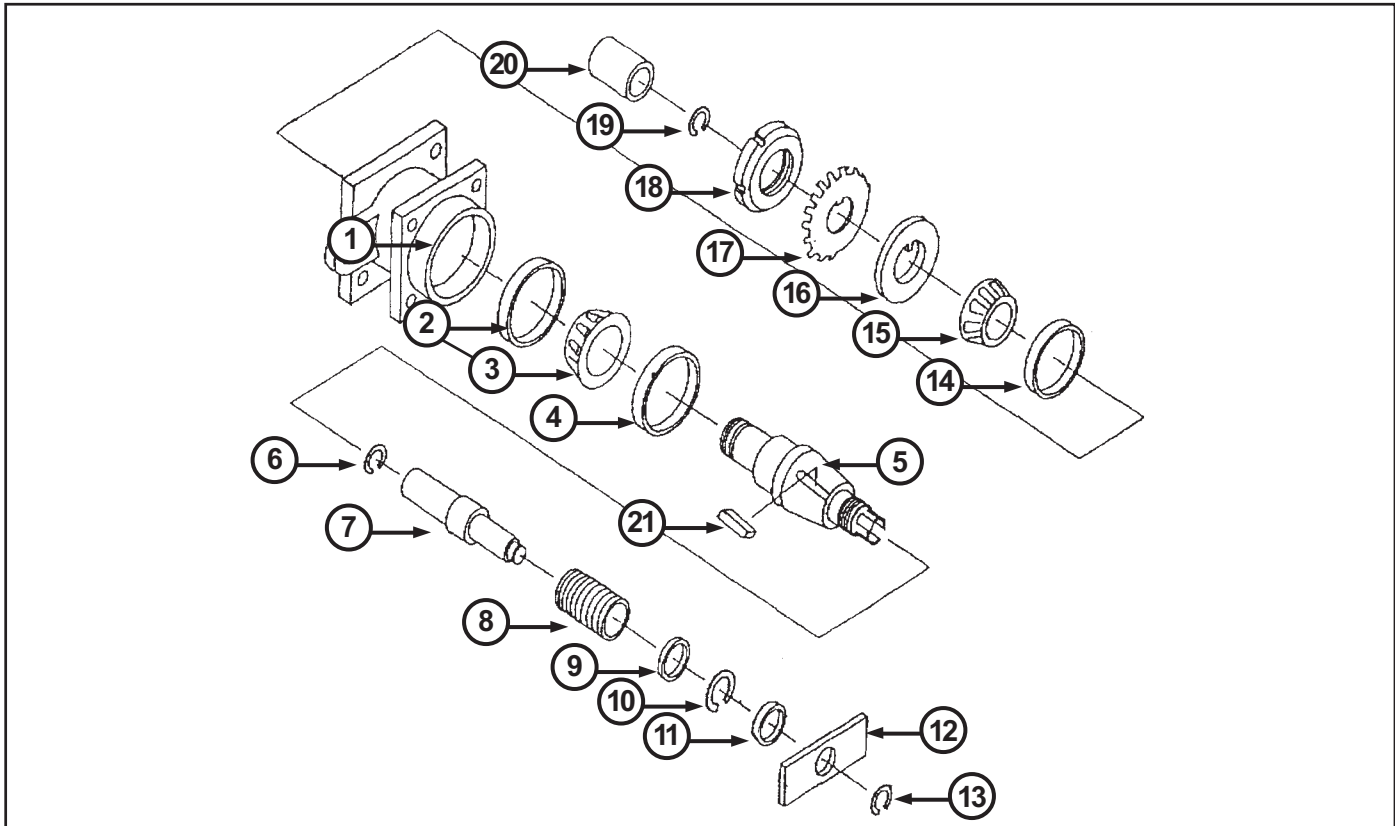

| ITEM | PART NUMBER | LAKIN# | DESCRIPTION | QTY. |
|------|-------------|--------|--------------------------------------|------|
| 1 | N/A | 4207 | Housing w/Brake | 1 |
| 2 | 38776 | 3732 | Set, Bearing & Race, Outer #2 & #3 | 1 |
| 3 | 38776 | 3731 | Set, Bearing & Race, Outer #2 & #3 | 1 |
| 4 | 38775 | 3728 | Seal, Oil - Bearing | 1 |
| 5 | 38828 | 3718 | Spindle, Brake, Disconnect Hub | 1 |
| 6 | N/A | 3724 | Ret. Ring - Shaft (2) req'd | 1 |
| 7 | N/A | 3719 | Shaft | 1 |
| 8 | 38424 | 3735 | Spring, Shaft | 1 |
| 9 | 38845 | 3736 | Washer, Spring | 1 |
| 10 | N/A | 3725 | Ret. Ring - Spring | 1 |
| 11 | 38843 | 3727 | Seal, Oil, Shaft | 1 |
| 12 | N/A | 3721 | Handle, Shaft | 1 |
| 13 | N/A | 3726 | Ret. Ring - Handle | 1 |
| 14 | 38777 | 3730 | Set, Bearing & Race, Inner #14 & #15 | 1 |
| 15 | 38777 | 3729 | Set, Bearing & Race, Inner #14 & #15 | 1 |
| 16 | 38839 | 3976W | Washer, Tongued | 1 |
| 17 | 38827 | 3734 | Lockwasher, Inner | 1 |
| 18 | 38826 | 3733 | Locknut (2) req'd | 1 |
| 19 | N/A | 3723 | Ret. Ring - Sleeve | 1 |
| 20 | 38823 | 3720 | Sleeve, Brake Disconnect Hub | 1 |
| 21 | N/A | 3990 | Key, 0.312 sq. x 1" Long | 1 |

Brake Hub Assembly

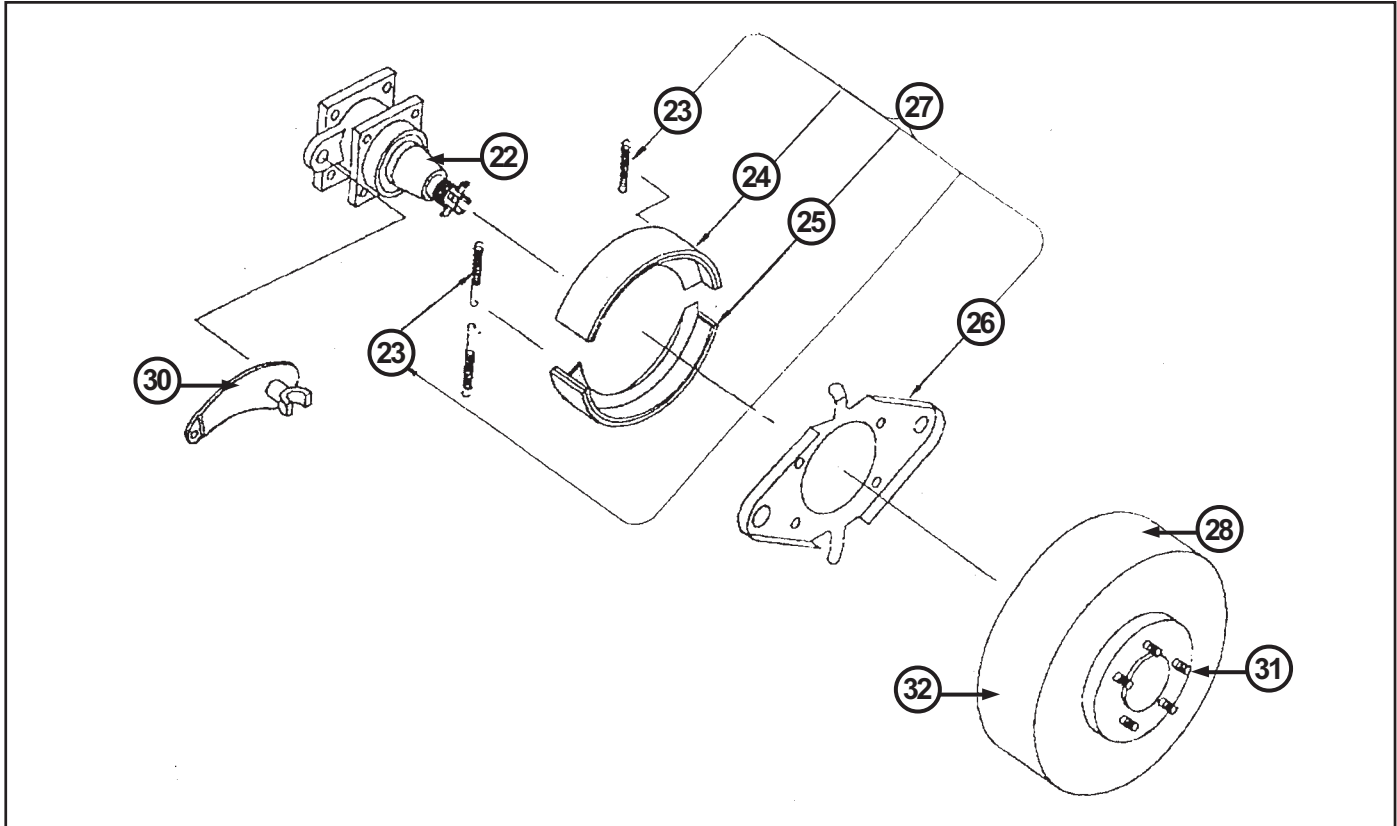

| ITEM | PART NUMBER | LAKIN# | DESCRIPTION | QTY. |
|------|-------------|--------|---|------|
| 22 | N/A | 3573 | Basic Hypac | 1 |
| 23 | N/A | 3713 | Spring (4) req'ed (Only shipped complete w/27.) | 1 |
| 24 | N/A | N/A | Brake Shoe (Only shipped complete w/27.) | 1 |
| 25 | N/A | N/A | Brake Shoe (Only shipped complete w/27.) | 1 |
| 26 | N/A | N/A | Backing Plate (Only shipped complete w/27.) | 1 |
| 27 | N/A | 3700 | Brake Shoe Assembly | 1 |
| 28 | N/A | 4314 | Hub - Drum | 1 |
| 29 | N/A | N/A | Spring (2) req'ed | 1 |
| 30 | N/A | 3701 | Brake Arm Shaft Assembly | 1 |
| 31 | N/A | 3709 | Bolt, Wheel Hub (5) req'ed | 1 |
| 32 | N/A | 4188 | Steel Drum | 1 |
| | | | Not Shown in Drawings | 1 |
| 5.1. | N/A | N/A | Spindle, Brake Disconnect (Used) | 1 |
| 17.1 | 38777 | N/A | Lockwasher, Inner (Used) | 1 |
| 18.1 | 38777 | N/A | Locknut (2) req'ed (Used) | 1 |
| 52 | 38050 | N/A | Gasket, Face Seal "A" Mount 4 Bolt | 1 |
| 53. | 38085 | 3823A | Assembly, Brake / Disconnect Hub | 1 |
| 54. | 38486 | 4107A | Wrench, Hypac hub Mount Nut | 1 |

Not Sold Separately

Parts

Hoses Set Sweeper Parker Valves

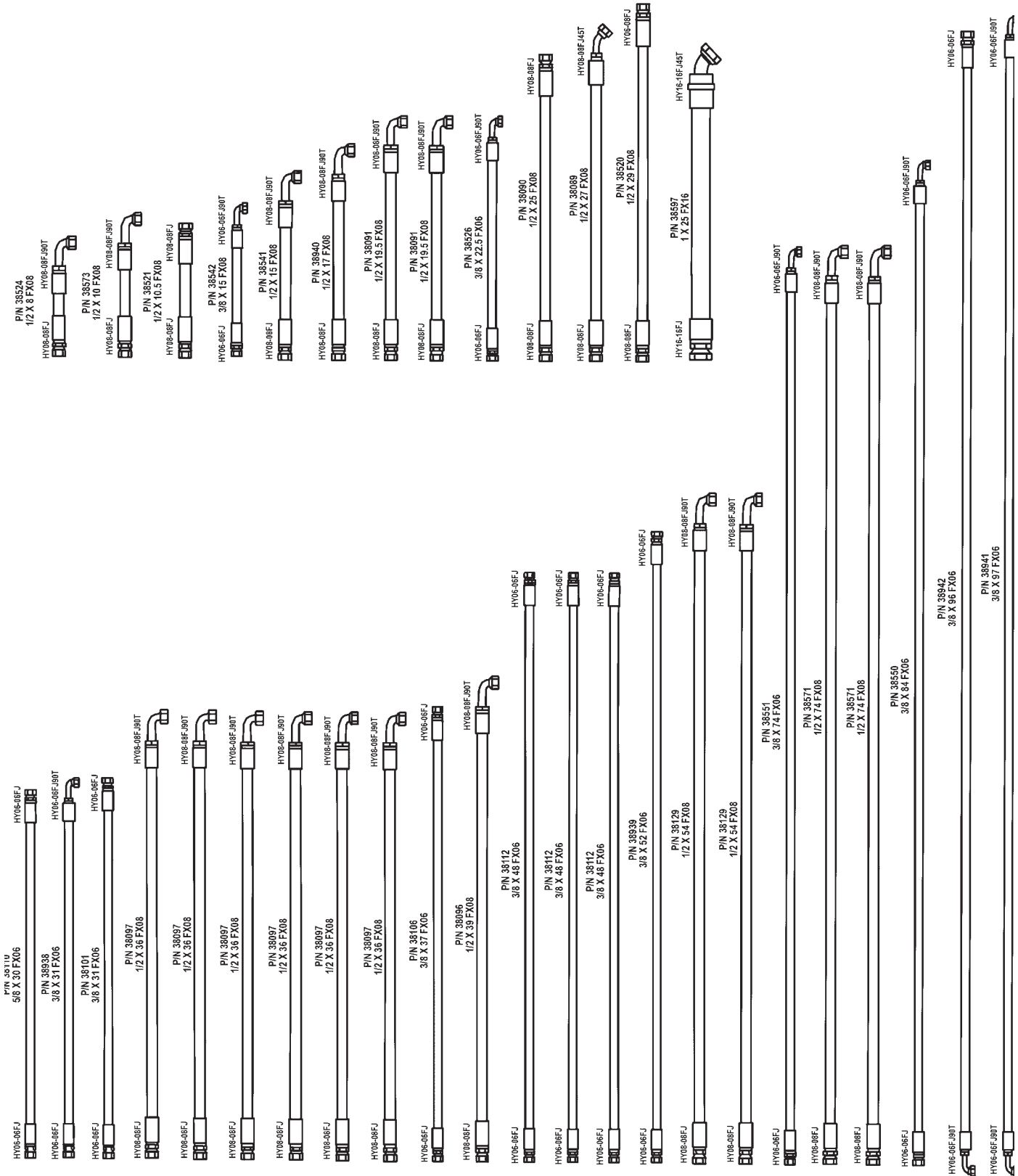

Hoses Set Sweeper Saver Dantoss Valves

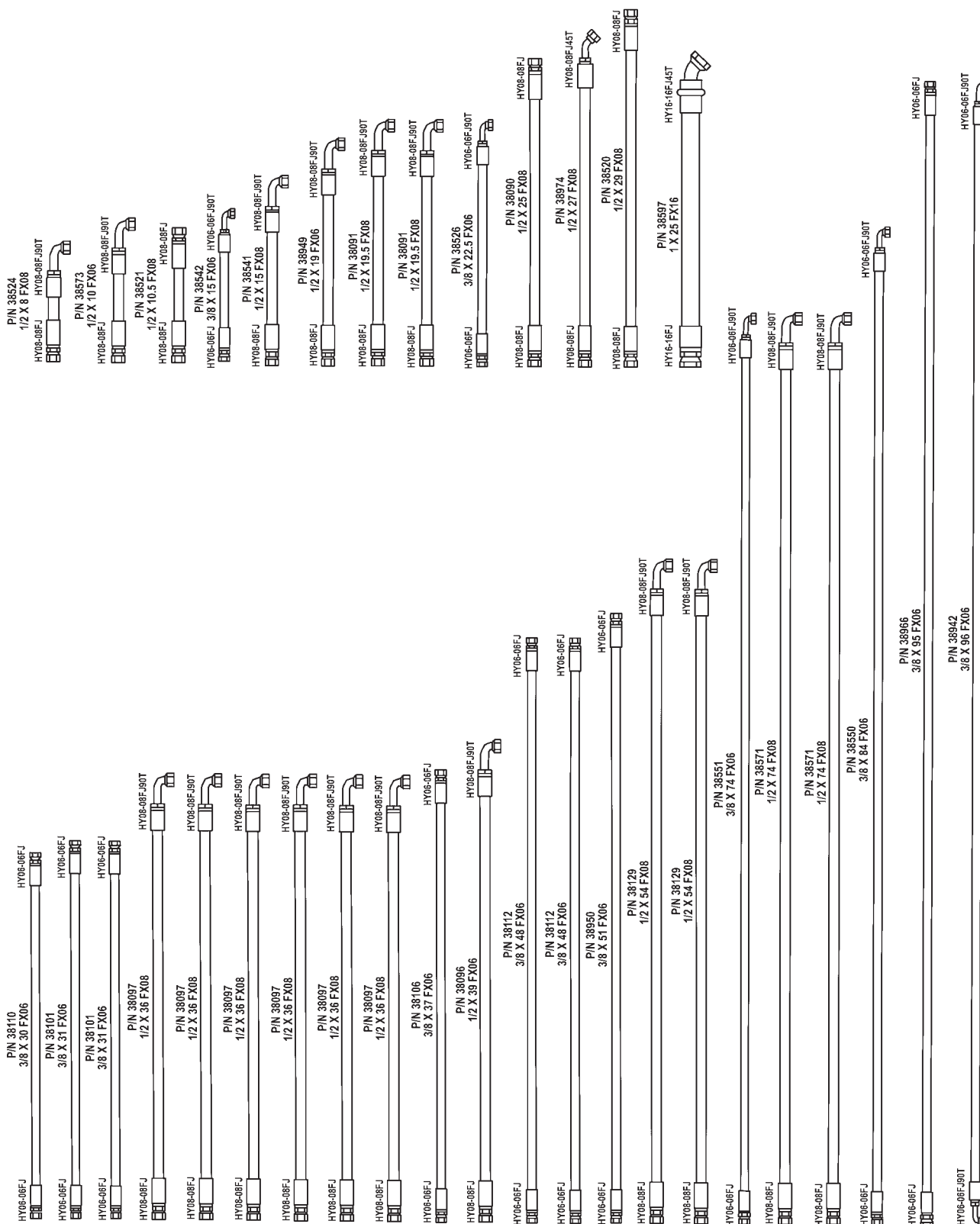

Hoses 6 Ft. Sweeper

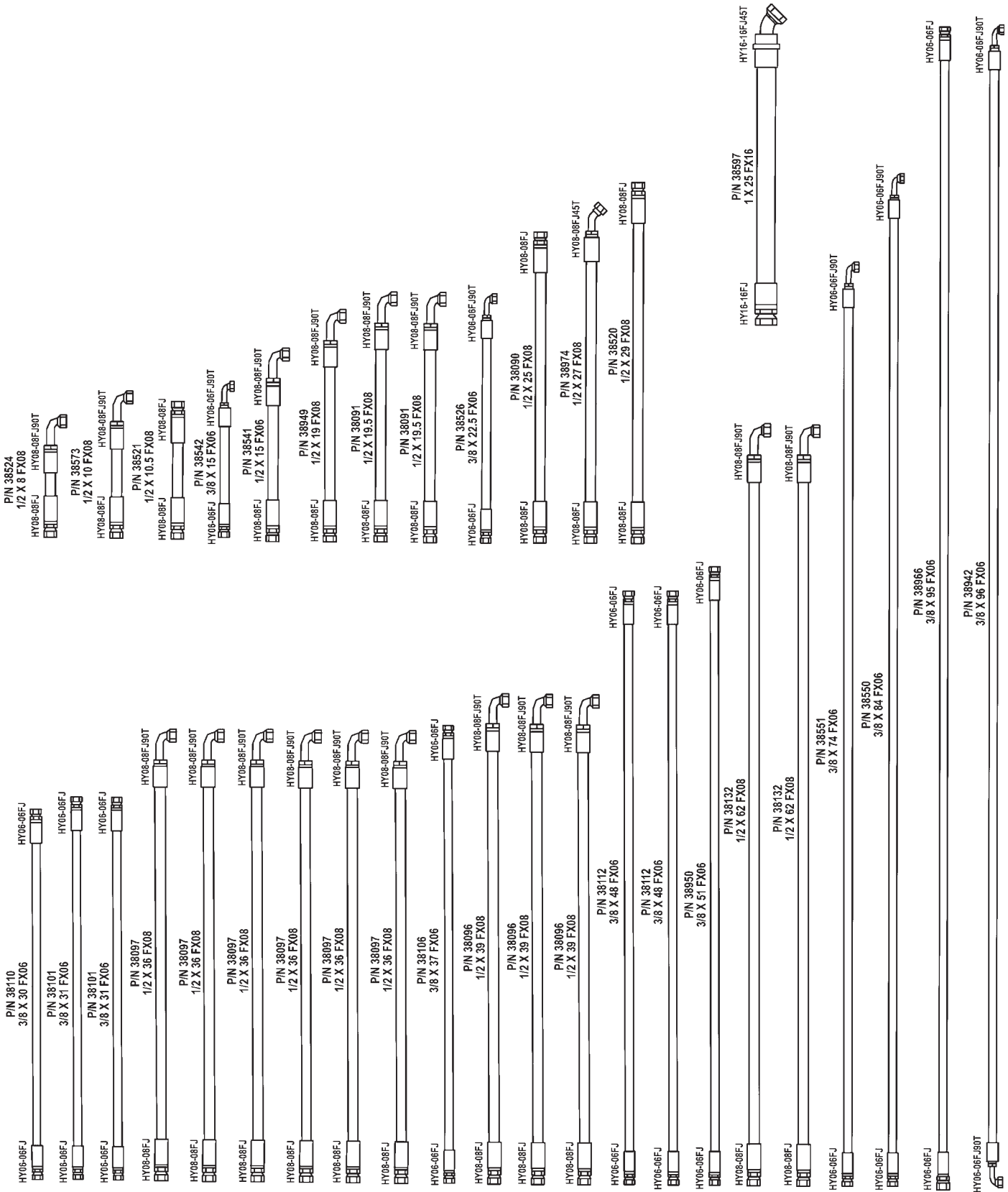

Low Pressure Filter Assembly

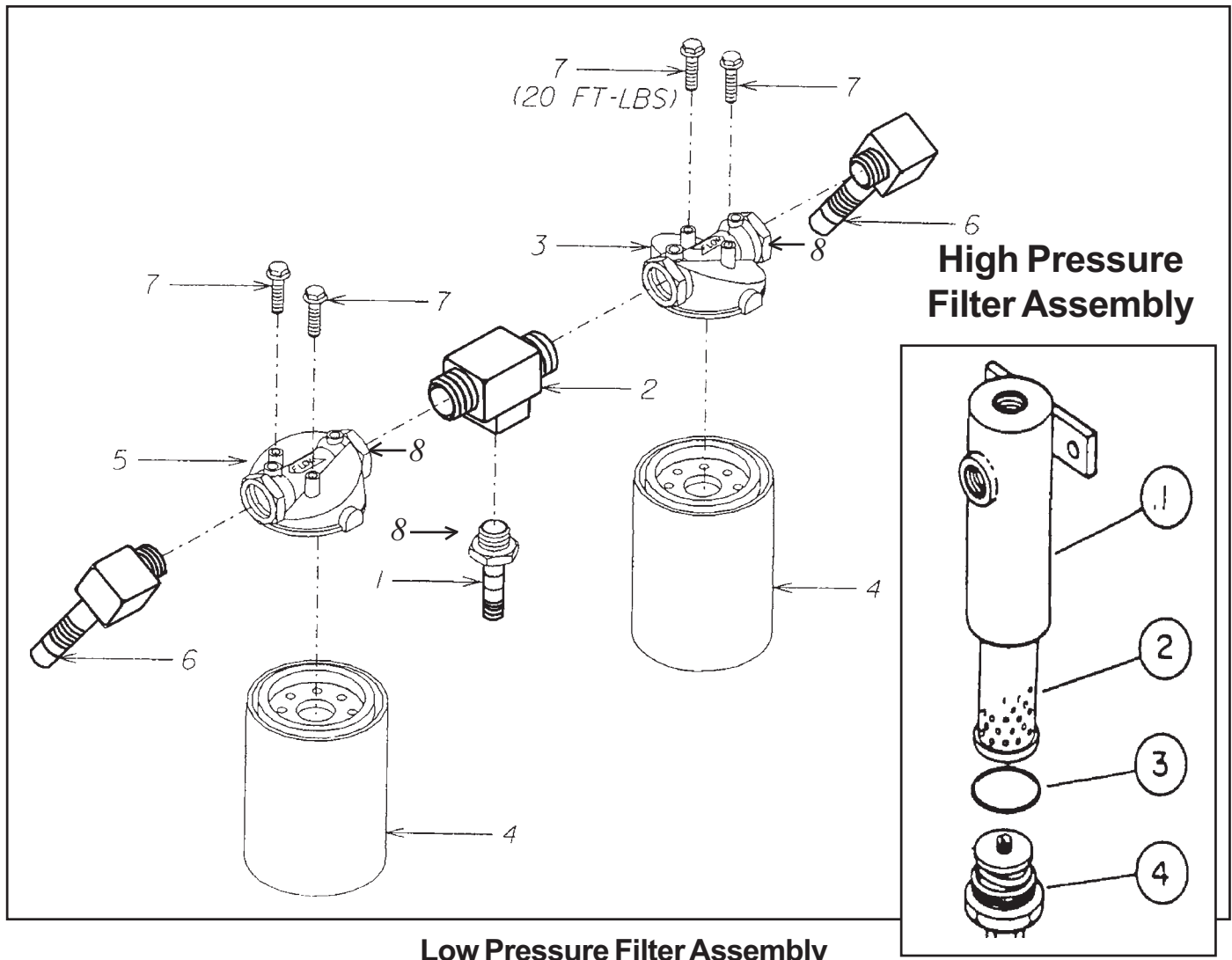

Low Pressure Filter Assembly

| ITEM | PART NUMBER | DESCRIPTION | QTY. |
|------|-------------|--|------|
| 1 | 20123 | Fitting, #8MVIC x #8MP Straight | 1 |
| 2 | 20163 | Fitting, T, 3/4" mp Across 3/4 FP Center | 1 |
| 3 | 38074 | Filter Base | 1 |
| 4 | 21002 | Filter Hydraulic, T5C/Sweeper | 2 |
| 5 | 38075 | Filter Base | 1 |
| 6 | 20172 | Fitting 1/2 mp x #8MVIC 90° | 2 |
| 7 | 22192 | Bolt 1/4" - 20 x 5/8 GR8Z | 4 |
| 8 | 20128 | Fitting 3/4" mp x 1/2 F Reducer | 3 |

High Pressure Filter Assembly

| ITEM | PART NUMBER | DESCRIPTION | QTY. |
|------|-------------|--|------|
| 1 | 38073 | Filter, Housing Assembly | 1 |
| 2 | 38297 | Filter, Element Internal | 1 |
| 3 | | Filter, O-Ring, Not Sold Separately | 1 |
| 4 | | Filter, Relief Nut Assembly, Not Sold Separately | 1 |

Parts

Ground Drive Assembly

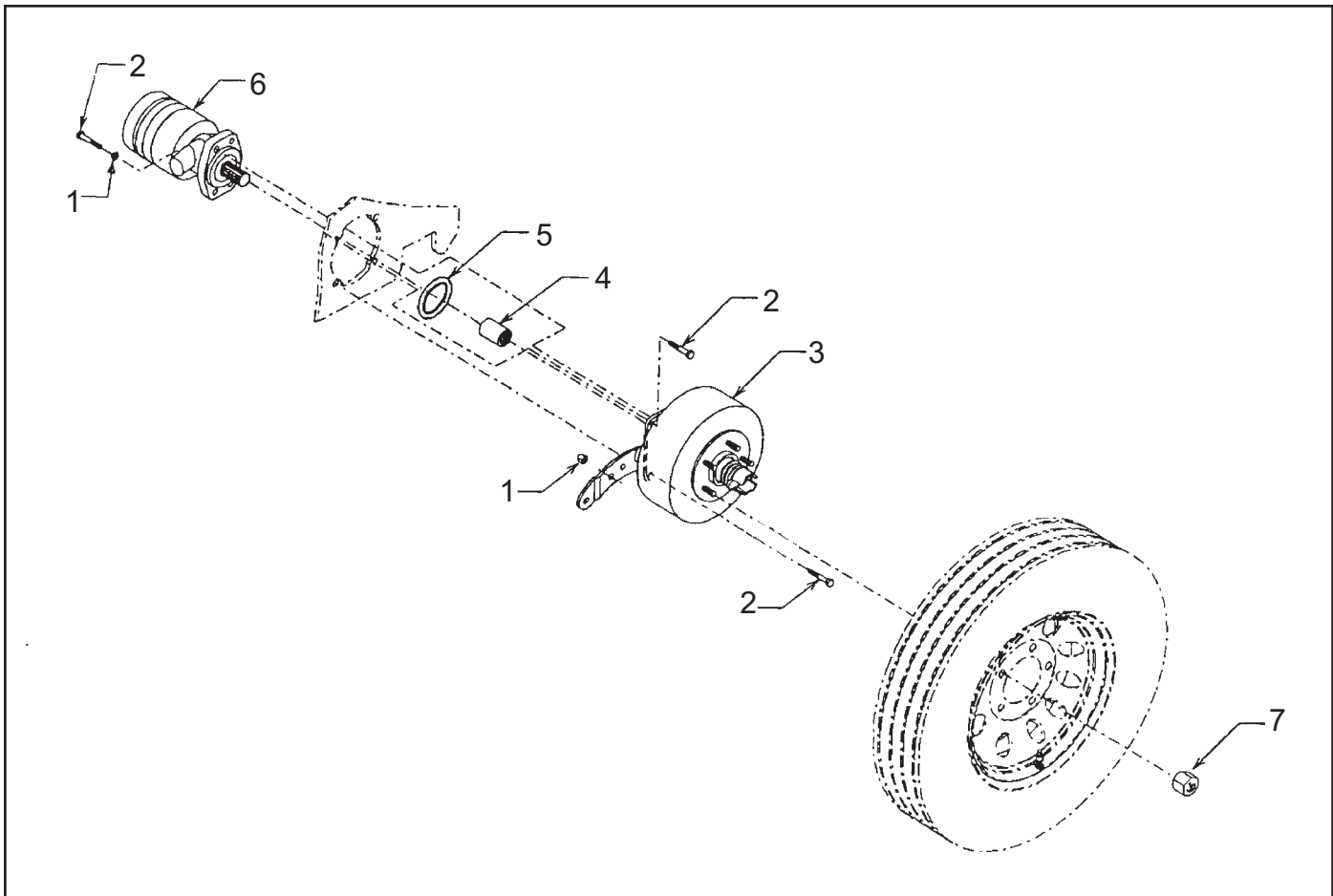

| ITEM | PART NUMBER | DESCRIPTION | QTY. |
|------|-------------|---|------|
| 1 | 24013 | Washer, 1/2", Split Lock | 4 |
| 2 | 22155 | Bolt, 1/2"-20 x 1/2" GR8 | 4 |
| 3 | 38085 | Brake Hub Assembly | 1 |
| 4 | 38823 | Sleeve, Brake Disconnect Hub | 1 |
| 5 | 38050 | Gasket, Motor-to/Lockout, Wheel Drive | 1 |
| 6 | 38867 | Motor, Drive, Wheel, W/Relief, After Ser#24TS0107 | 1 |
| 7 | 28506 | Nut, Lug, 1/2" ID x 13/16" on, Front/Rear | 5 |

Gear Pump Part Number 66000 Gas / 66001 Diesel

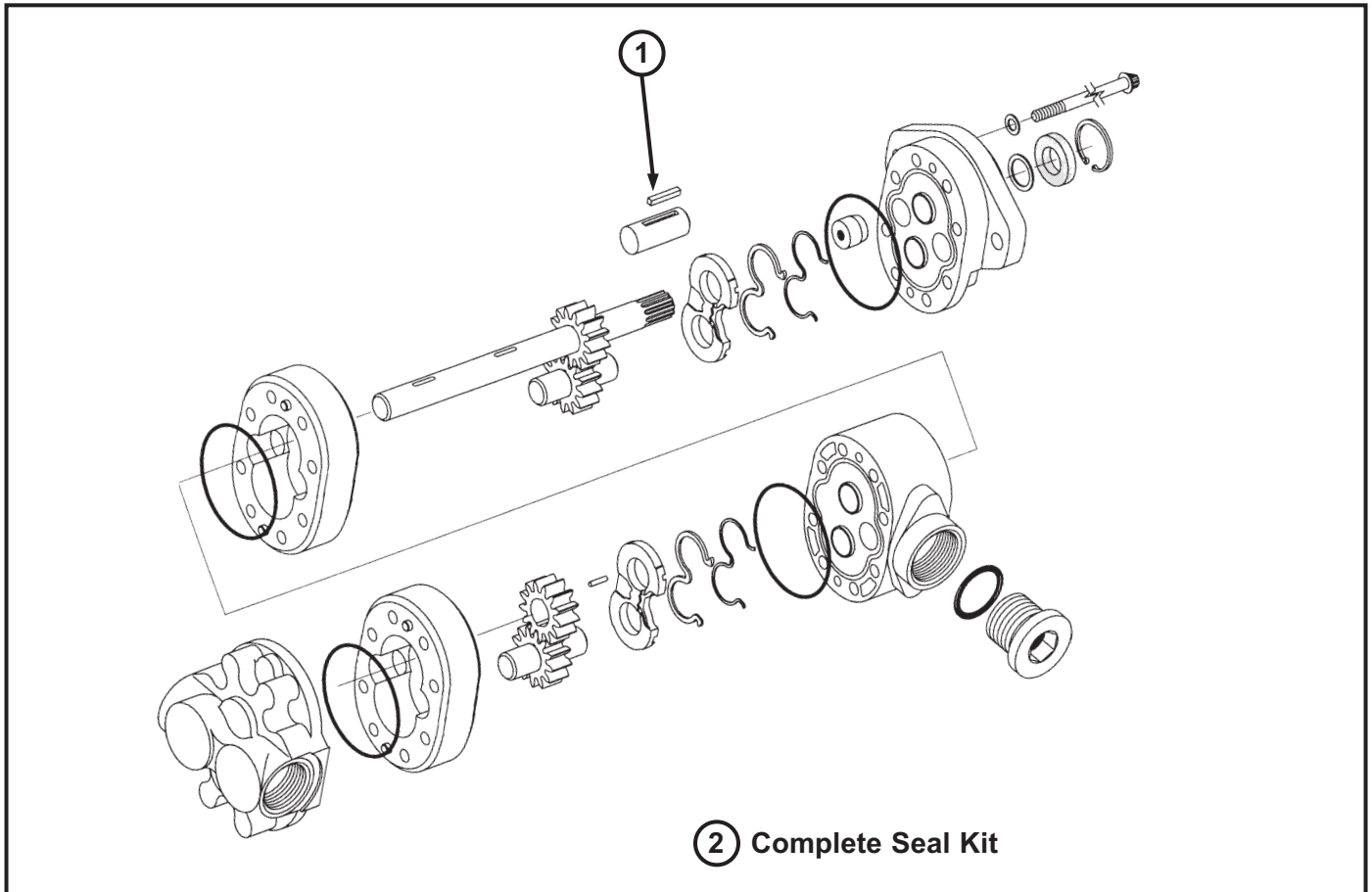

| ITEM | PART NUMBER | DESCRIPTION | QTY. |
|------|-------------|-----------------------------|------|
| 1 | 64049 | Key, Coupler, Cessna | 1 |
| 2 | 66030 | Kit, Seal, Double Gear Pump | 1 |

| ITEM | PART NUMBER | DESCRIPTION | QTY. |
|------|-------------|---|------|
| 1 | 60401 | Retaining Ring | 1 |
| 2 | 60402 | Shaft Seal | 1 |
| 3 | 60403 | Washer | 1 |
| 4 | 60404 | Retaining Ring | 2 |
| 5 | 60405 | Bearing Race | 2 |
| 6 | 60406 | Bearing, Thrust | 1 |
| 7 | 60471 | Key | 1 |
| 8 | 38892 | Drive Shaft | 1 |
| 9 | 60409 | Housing Assembly | 1 |
| 10 | 60410 | Bearing | 2 |
| 11 | 60411 | Inner Race | 2 |
| 12 | 60412 | O-Ring, 3/32" x 15/16", Outer Pintle | 2 |
| 13 | 60465 | Sleeve Cover | 1 |
| 13A | 60415 | Trunnion Cover | 1 |
| 13B | 60561 | Washer | 1 |
| 14 | 60414 | Retaining Ring | 2 |
| 14A | 60562 | Seal, Pintle | 1 |
| 15 | 60418 | Seal Cover | 1 |
| 17 | 60564 | Screws, Trunnion Cover | 2 |
| 18 | 60516 | O-Ring, Outer Pintle | 1 |
| 19 | 60517 | Camplate, For Eaton Trans. | 1 |
| 19 | 60417 | Camplate, For Cessna Trans. | 1 |
| 29 | 60422 | Rotating Kit Assembly | 1 |
| 31 | 60429 | Housing, Gasket | 1 |
| 33 | 60533 | Backplate Assy., Eaton, with Power Steering | 1 |
| 33A | 60535 | Backplate Assy., w/valve plate, Eaton | 1 |
| 33B | 60432 | Backplate Assy., Cessna, without Power Steering | 1 |
| 35 | 60436 | Plug Assembly | 2 |
| 36 | 60435 | O-Ring 3/32" x 7/8" ID, Back Plate | 1 |
| 37 | 60463 | Spring, Transmission, Relief Valve | 2 |
| 38 | 60467 | Relief Valve Assembly | 2 |
| 39 | 60433 | Plug Assembly | 1 |
| 40 | 60440 | Retaining Ring | 1 |
| 41 | 60441 | Separator Plug | 1 |
| 42 | 60442 | O-Ring, 3/32" x 7/8" | 1 |
| 43 | 60454 | Spreader | 1 |
| 44 | 60437 | O-Ring, 1/16" x 3/8" | 1 |
| 45 | 60443 | Coupler | 1 |
| 50 | 64050 | Gerotor and Coupler | 1 |
| 51 | 60449 | O-Ring, Molded | 1 |
| 52 | 60453 | Adapter Assembly without Power Steering | 1 |
| | 60553 | Adapter Assembly with Power Steering | |
| | 64058 | Adapter Assembly with Power Steering - Diesel | |
| 53 | 60450 | Check Valve Assembly | 2 |
| 54 | 60452 | Back Up Washer | 2 |
| 55 | 60455 | O-Ring, 1/16" x 7/16" | 2 |
| 56 | 60456 | Steel Ball | 2 |
| 57 | 60457 | Pin | 2 |
| 58 | 60461 | Poppet Filter Relief | 1 |
| 59 | 60463 | Spring | 1 |
| 60 | 60560 | Spring Retainer | 1 |
| 61 | 60469 | Plug Assembly | 1 |
| 62 | 60466 | O-Ring, 3/32" x 41/64" | 1 |
| 64 | 60464 | O-Ring, 1/16" x 3/4" | 1 |
| 65 | 60465 | Cover Plate | 1 |
| 66 | 60459 | Cap Screw | 2 |
| 67 | 60534 | Plate, Valve | 1 |
| *S | 64100 | Seal Repair Kit, Cessna | 1 |
| *S | 64101 | Seal Repair Kit Eaton | 1 |
| *S | 60043 | Rotating Rebuild Kit, Cessna | 1 |
| *S | 60564 | Screws, Trunnion Cover | 2 |
| 68 | 60464 | O-Ring in Back | 1 |

Parts

110A Brush Motor Exploded View Parker

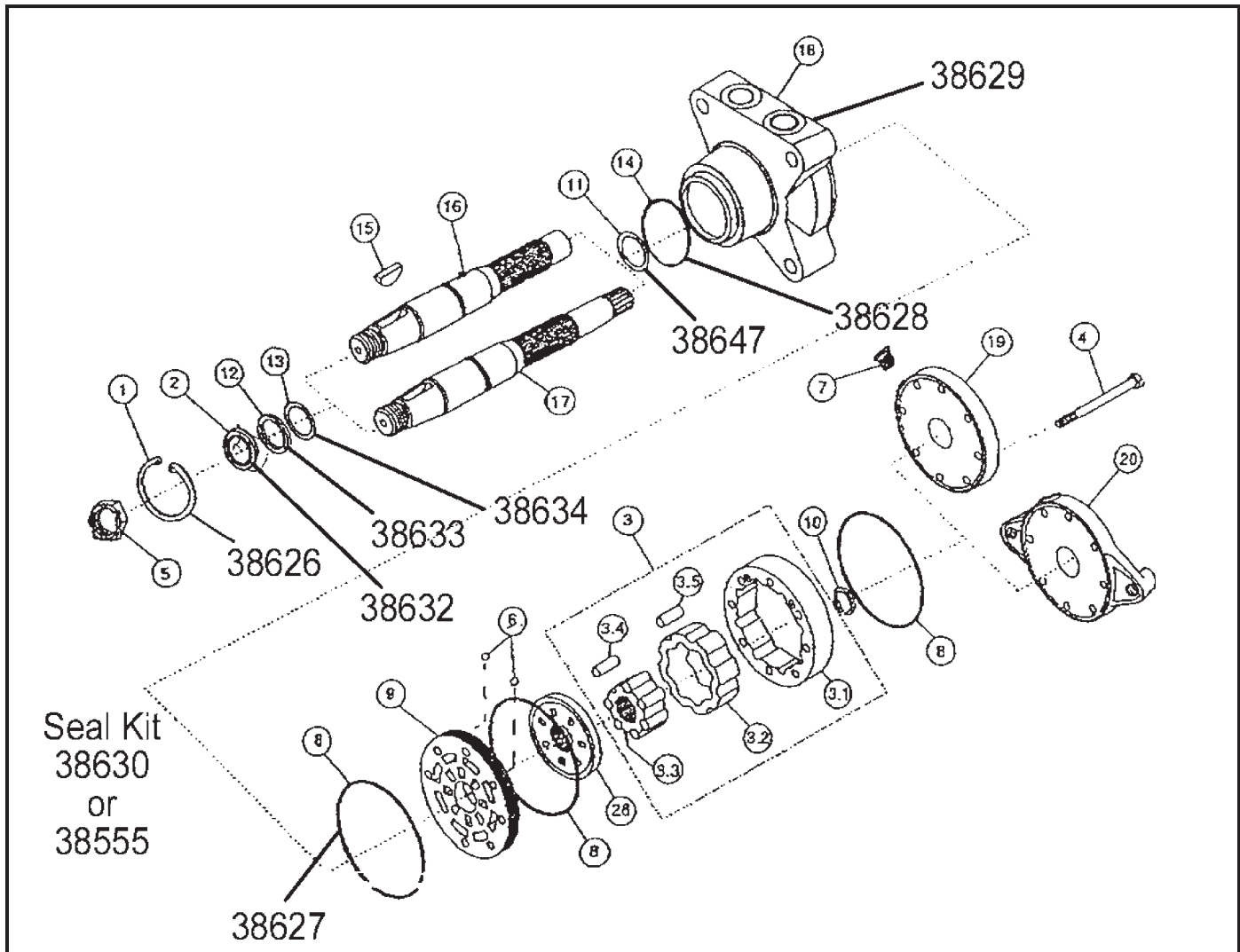

| ITEM | PART NUMBER | DESCRIPTION | QTY. |
|------|-------------|---|------|
| 1 | 38626 | Ring, Snap, Seal, or Motor, Broom Core Parker | 1 |
| 2 | 38627 | Seal, Square Ring or Motor, Broom Core Parker | 3 |
| 3 | 38632 | Seal/Retainer Assembly, Broom Core Parker | 1 |
| 4 | 38633 | Washer, Thrust Drive Motor, Broom Core Parker | 1 |
| 5 | 38634 | Washer, Thrust Hard #13, Broom Core Parker | 1 |
| 6 | 38647 | Washer, Thrust #11, Broom Core Parker | 1 |
| 7 | 38628 | Seal, O-Ring, Drive Motor, Brush, Broom Core Parker | 1 |
| 8 | 38629 | Body, 4 Bolt Thru Mounting, Broom Core Parker | 1 |
| 9 | 38630 | Seal Kit, Drive Motor, Brush, Broom Core Parker | 1 |

Kubota Engine Left Side

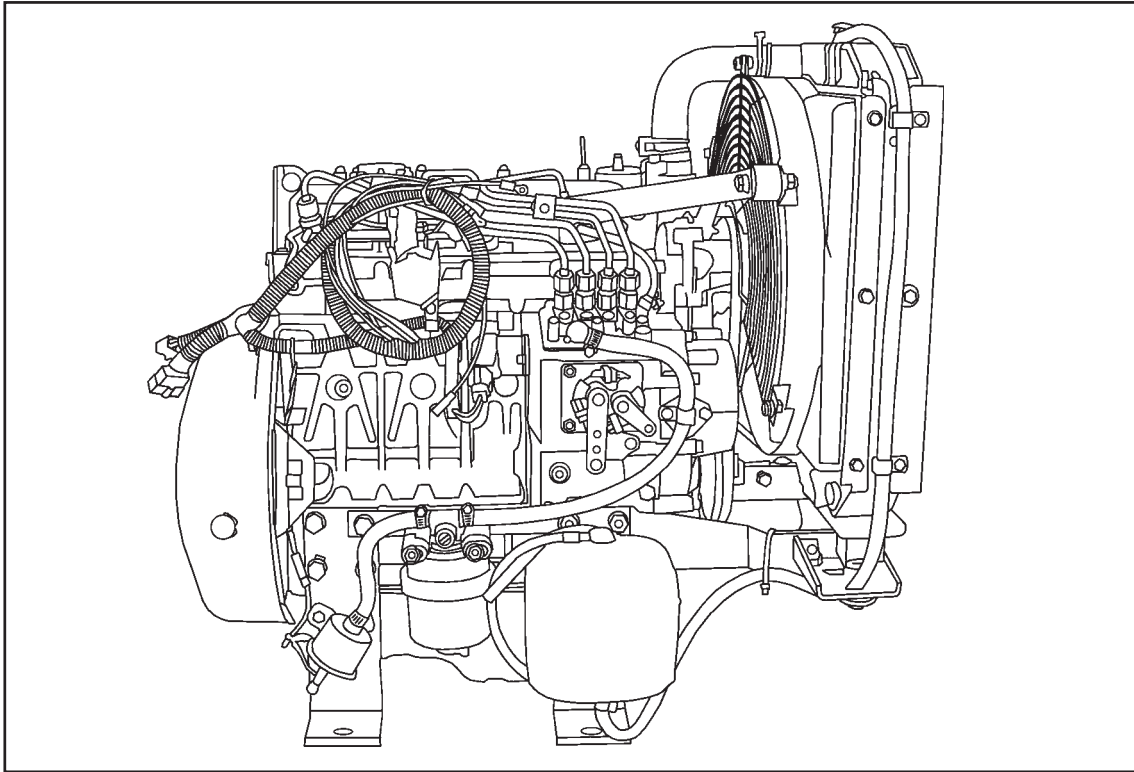

Kubota Engine Right Side

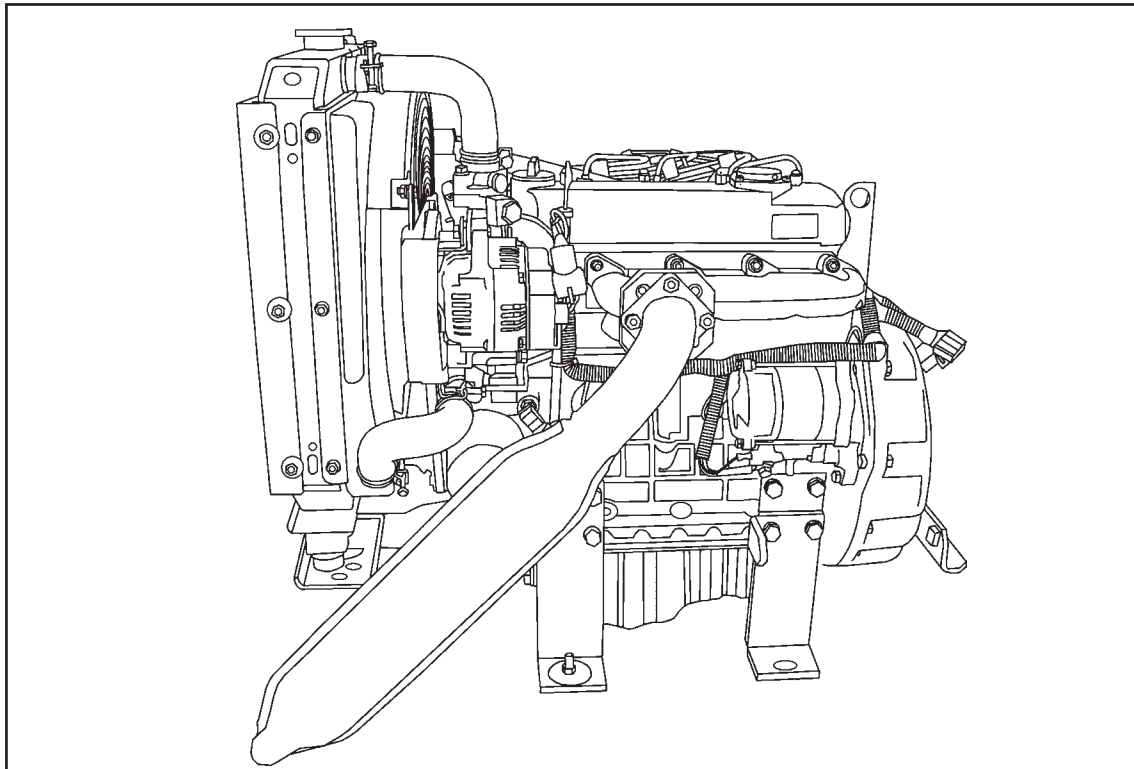

Hydraulic Oil Change and Type Specifications

When your machine is new, the hydraulic system oil and filter should be changed within the first 50 hours of use and every 250 thereafter. Refill the hydraulic reservoir with engine oil type API SF.CD 10W when outside temperature is above 40 degrees F. Use engine oil type API SF.CD 10 weight when outside temperature is below 40 degrees F. It is important to follow these instructions to alleviate any cold weather engine starting problems and any pressure or heat related component failure.

***DO NOT USE HYDRAULIC OIL!
MAJOR DAMAGE WILL RESULT!***

For your engine oil requirements and change intervals refer to your engine owners manual.

WHETHER YOU OWN
ONE TERRAMITE OR 100,
CONTACT OUR
PARTS/SERVICE DEPARTMENT
FOR ANY ADVICE
YOU MAY NEED TO
TAILOR A STOCK LIST
TO YOUR SPECIFIC NEEDS

600 Goff Mountain Road ♦ P.O. Box 7146, Charleston, WV 25356-7146
1-800-428-3772 ♦ Fax 1-800-776-4845
International 1-304-776-4231 ♦ Fax 1-304-776-4845
www.terramite.com

Hydraulic Schematic #1, Main Propel Drive Version 1

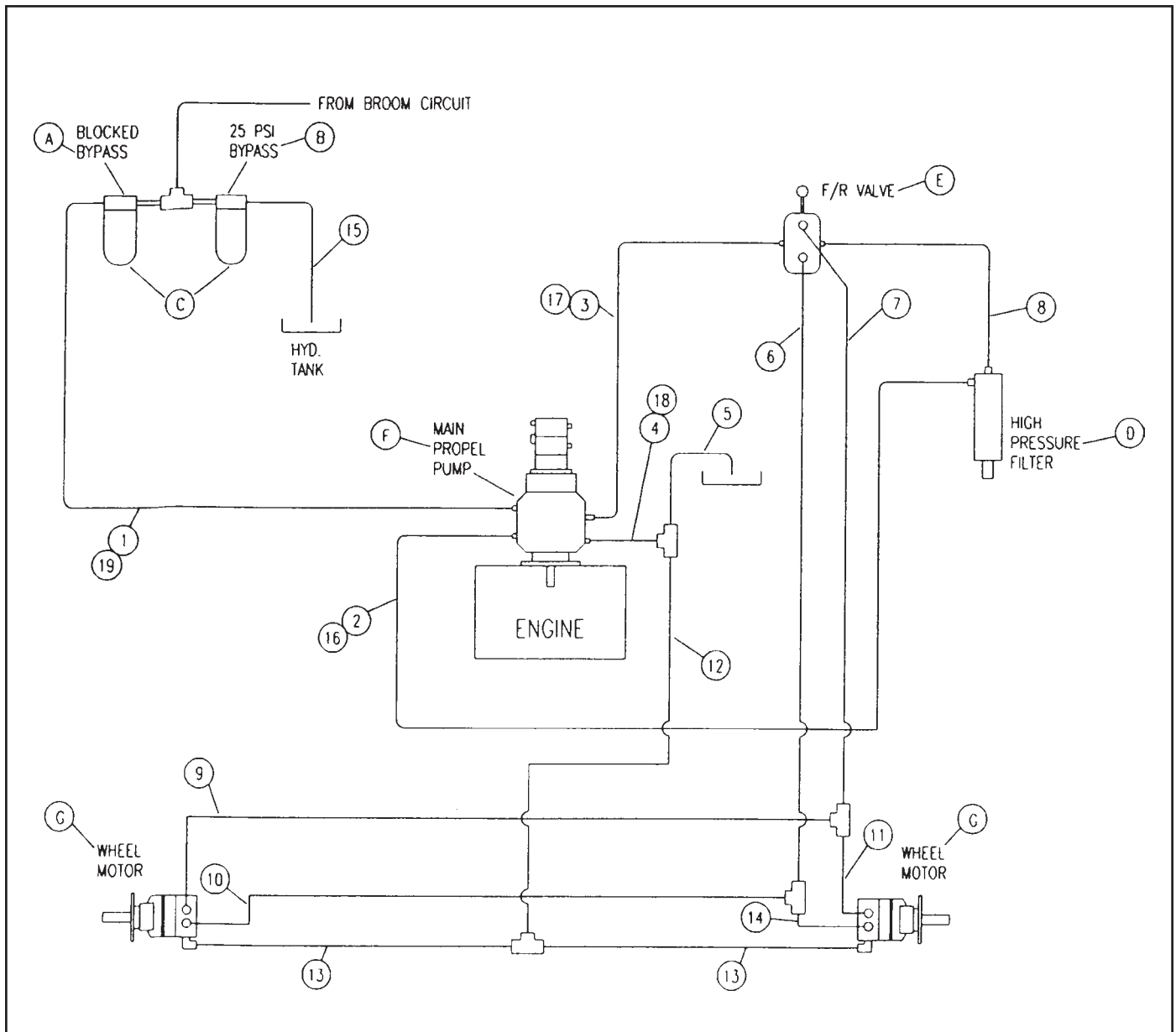

| ITEM | PART NUMBER |
|------|---------------|
| A | 38075 |
| B | 38074 |
| C | 38076 |
| D | 38019 |
| E | 38086 |
| F | 38058 |
| G | 38057 |
| 1 | 38088 |
| 2 | 38089 - Deutz |

| ITEM | PART NUMBER |
|------|---------------|
| 3 | 38090 |
| 4 | 38091 - Duetz |
| 5 | 38092 |
| 6 | 38090 |
| 7 | 38094 |
| 8 | 38095 |
| 9 | 38096 |
| 10 | 38097 |
| 11 | 38098 |

| ITEM | PART NUMBER |
|------|----------------|
| 12 | 38099 |
| 13 | 38100 |
| 14 | 38101 |
| 15 | 38102 |
| 16 | 38215 - Kubota |
| 17 | 38429 - Kubota |
| 18 | 38430 - Kubota |
| 19 | 38431 - Kubota |

Hydraulics

Hydraulic Schematic #2, Steering / Auxiliary Version 1

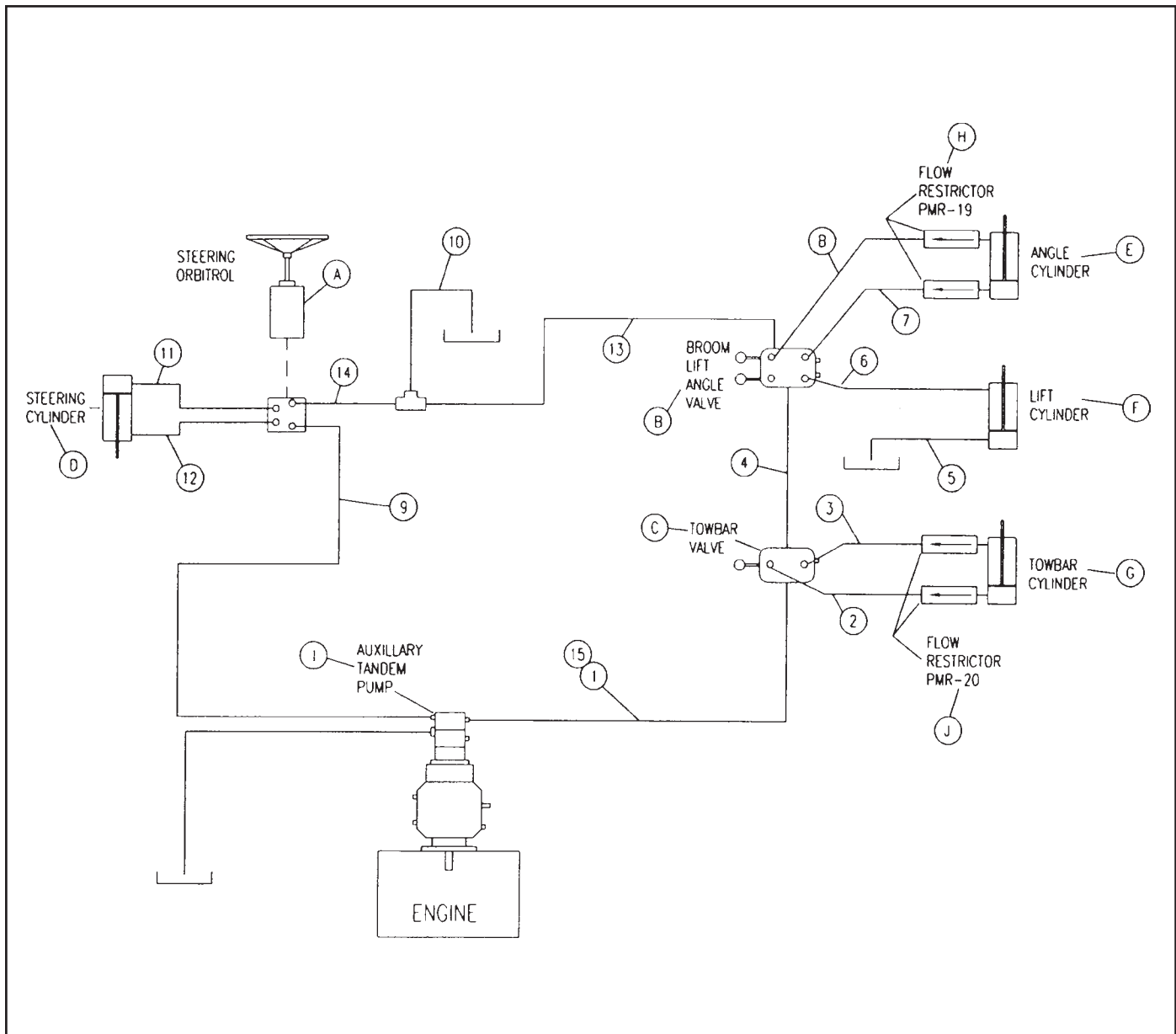

| ITEM | PART NUMBER |
|------|-------------|
| A | 38051 |
| B | 38087 |
| C | 38026 |
| D | 38015 |
| E | 38017 |
| F | 38016 |
| G | 38018 |
| H | 38020 |
| I | 38081 |

| ITEM | PART NUMBER |
|------|----------------|
| J | 38105 |
| 1 | 38108 - Kubota |
| 2 | 38106 |
| 3 | 38107 |
| 4 | 38108 |
| 5 | 38109 |
| 6 | 38110 |
| 7 | 38111 |
| 8 | 38112 |

| ITEM | PART NUMBER |
|------|---------------|
| 9 | 38473 |
| 10 | 38091 |
| 11 | 38115 |
| 12 | 38116 |
| 13 | 38117 |
| 14 | 38091 |
| 15 | 38119 - Deutz |

Hydraulic Schematic #3, Broom Drive Version 1

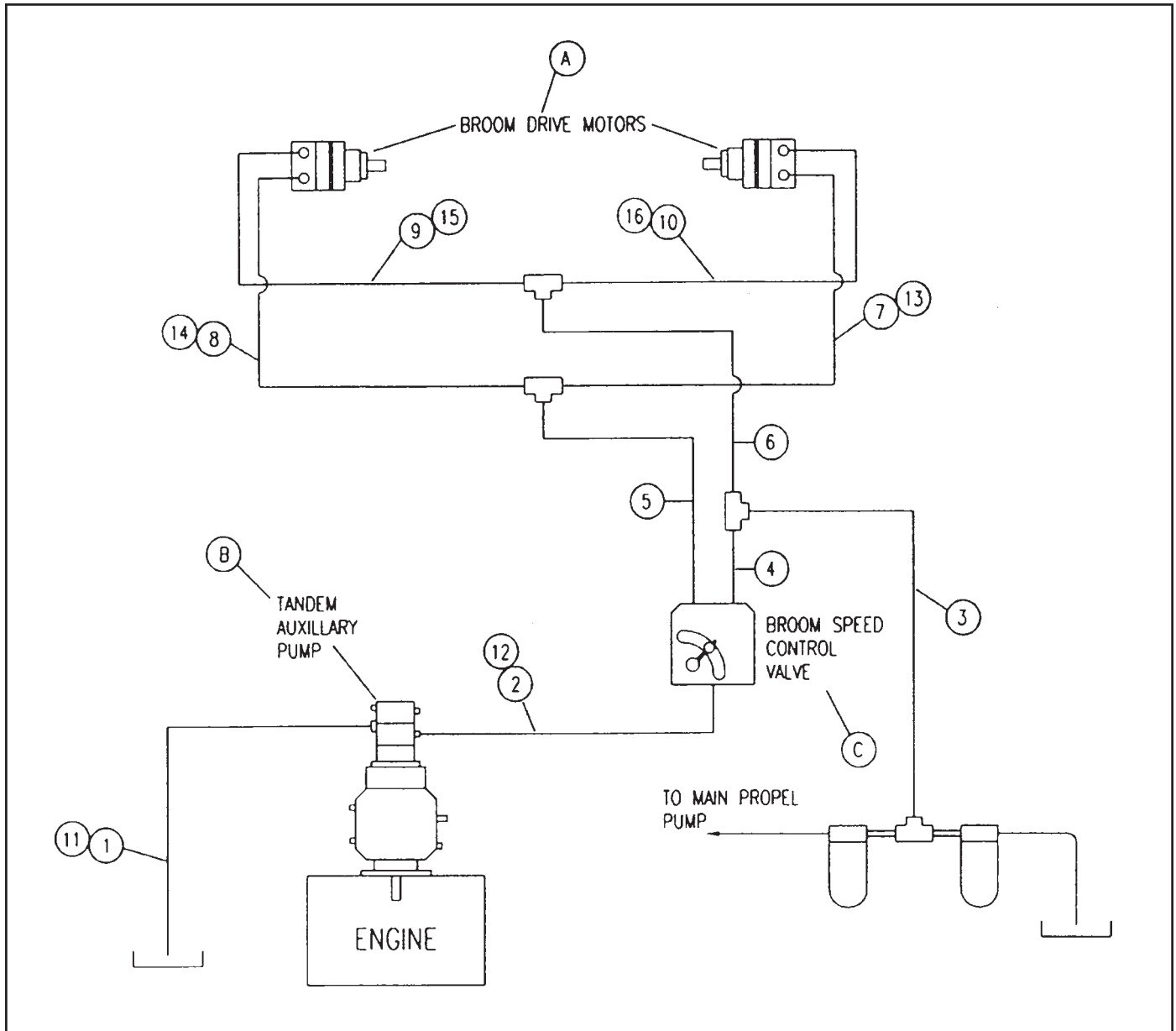

| ITEM | PART NUMBER |
|------|----------------|
| A | 38052 |
| B | 38081 |
| C | 38082 |
| 1 | 38121 - Kubota |
| 2 | 38125 - Kubota |
| 3 | 38125 |
| 4 | 38126 |
| 5 | 38127 |
| 6 | 38128 |

| ITEM | PART NUMBER |
|------|---------------|
| 7 | 38129 (8') |
| 8 | 38131 (8') |
| 9 | 38133 (8') |
| 10 | 38135 (8') |
| 11 | 38122 - Deutz |
| 12 | 38124 - Deutz |
| 13 | 38130 (6') |
| 14 | 38132 (6') |
| 15 | 38134 (6') |

| ITEM | PART NUMBER |
|------|-------------|
| 16 | 38136 (6') |

Hydraulics

Hydraulic Schematic #1, Main Propel Drive Version 2

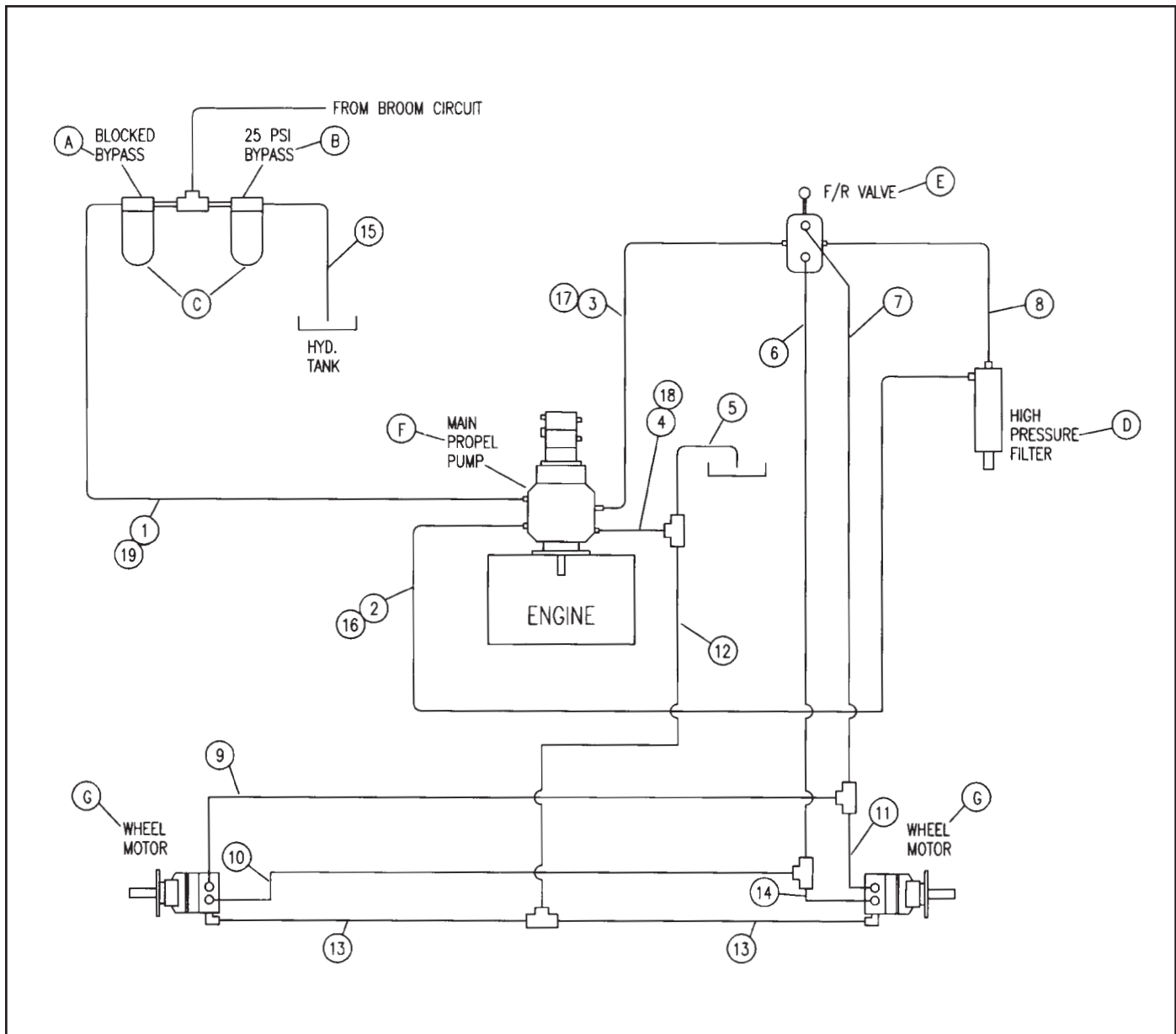

| ITEM | PART NUMBER |
|------|---------------|
| A | 38075 |
| B | 38074 |
| C | 38076 |
| D | 38019 |
| E | 38086 |
| F | 38058 |
| G | 38057 |
| 1 | 38088 |
| 2 | 38089 - Deutz |

| ITEM | PART NUMBER |
|------|---------------|
| 3 | 38090 |
| 4 | 38091 - Deutz |
| 5 | 38092 |
| 6 | 38090 |
| 7 | 38094 |
| 8 | 38095 |
| 9 | 38096 |
| 10 | 38097 |
| 11 | 38098 |

| ITEM | PART NUMBER |
|------|----------------|
| 12 | 38099 |
| 13 | 38100 |
| 14 | 38101 |
| 15 | 38102 |
| 16 | 38215 - Kubota |
| 17 | 38429 - Kubota |
| 18 | 38430 - Kubota |
| 19 | 38431 - Kubota |

Hydraulic Schematic #2, Steering / Auxiliary Version 2

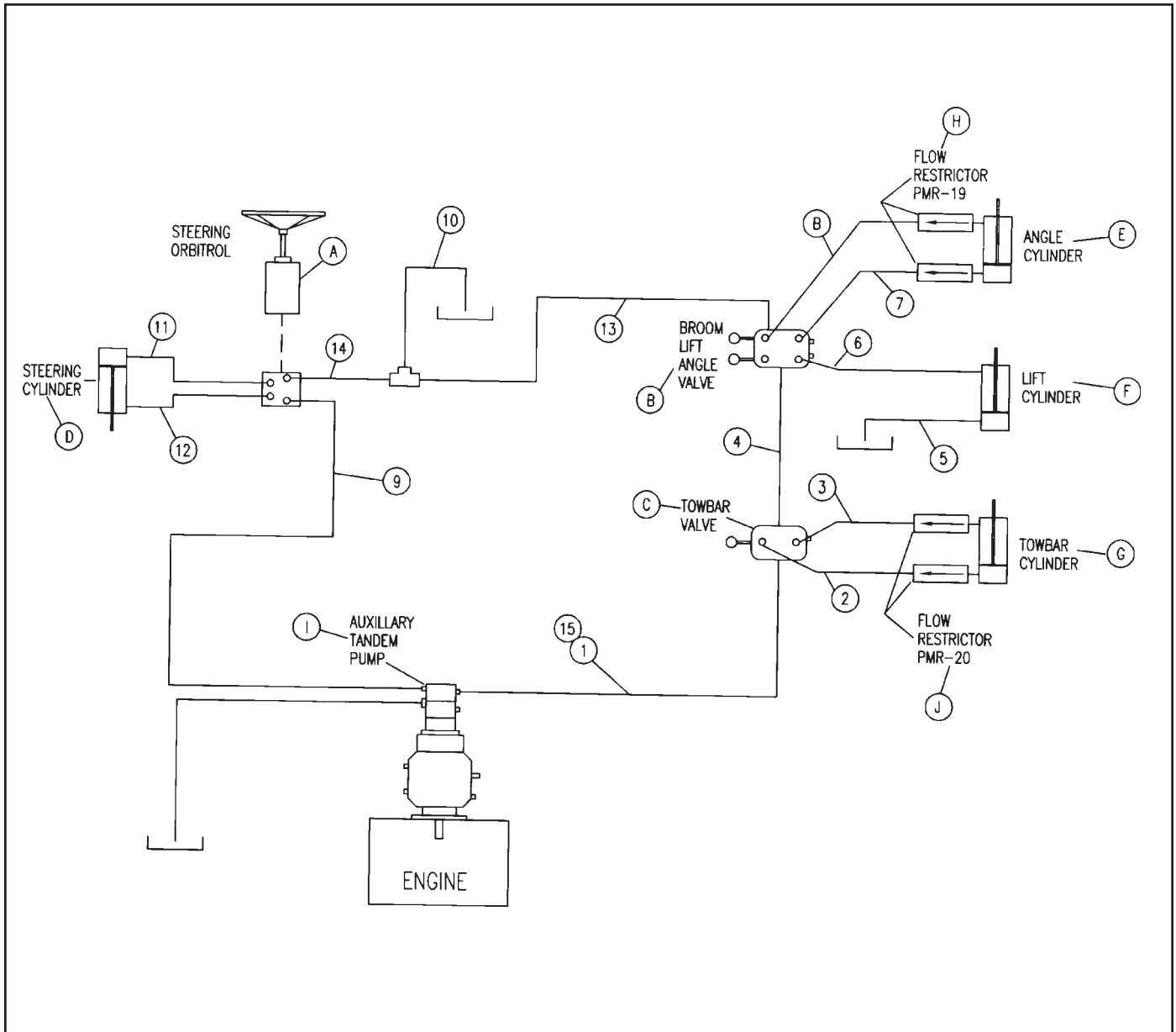

| ITEM | PART NUMBER |
|------|-------------|
| A | 38051 |
| B | 38087 |
| C | 38026 |
| D | 38015 |
| E | 38017 |
| F | 38016 |
| G | 38018 |
| H | 38020 |
| I | 38081 |

| ITEM | PART NUMBER |
|------|----------------|
| J | 38105 |
| 1 | 38108 - Kubota |
| 2 | 38106 |
| 3 | 38107 |
| 4 | 38108 |
| 5 | 38109 |
| 6 | 38110 |
| 7 | 38111 |
| 8 | 38112 |

| ITEM | PART NUMBER |
|------|---------------|
| 9 | 38473 |
| 10 | 38091 |
| 11 | 38115 |
| 12 | 38116 |
| 13 | 38117 |
| 14 | 38091 |
| 15 | 38119 - Deutz |

Hydraulics

Hydraulic Schematic #3, Broom Drive Version 2

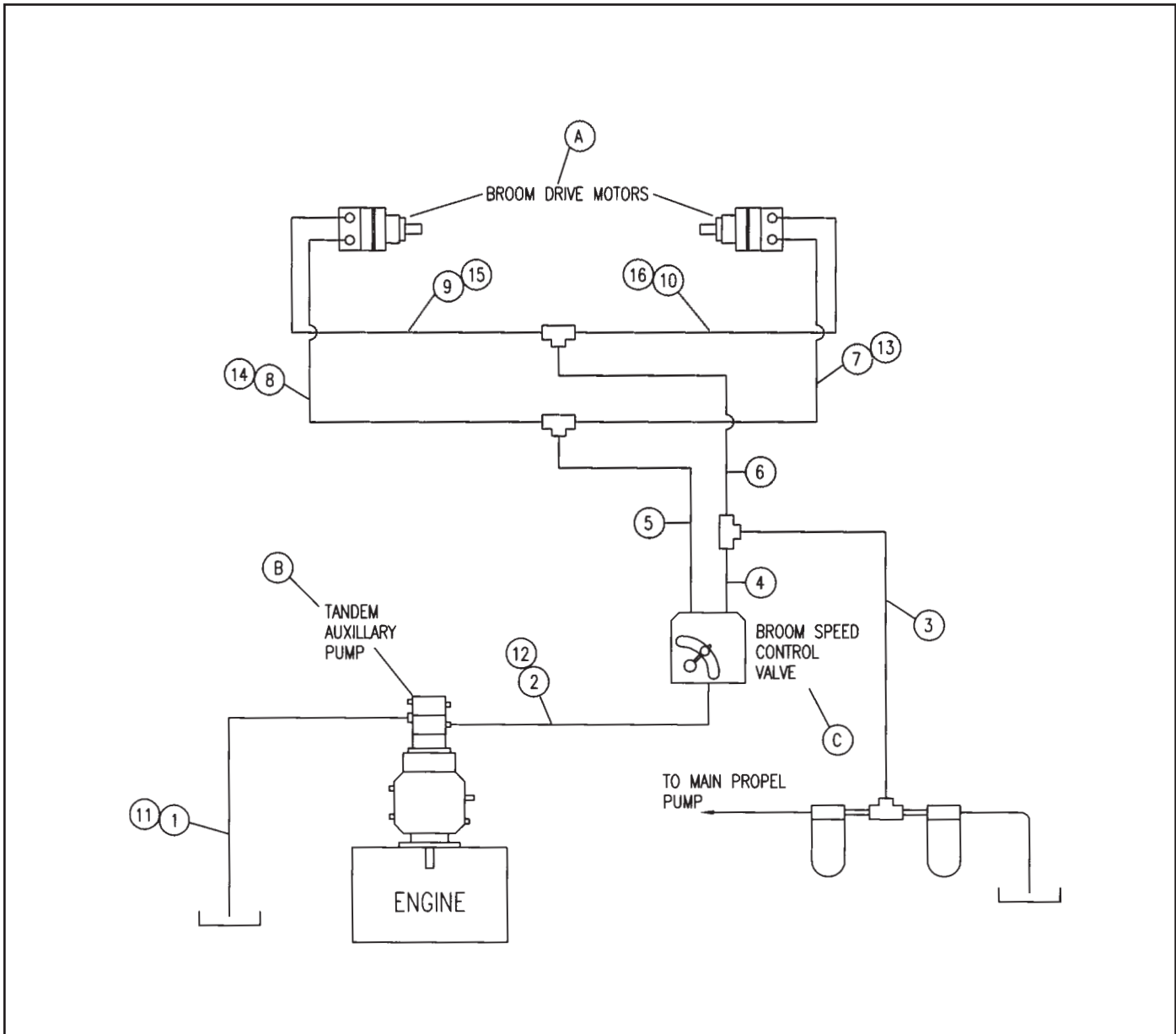

| ITEM | PART NUMBER |
|------|----------------|
| A | 38052 |
| B | 38081 |
| C | 38082 |
| 1 | 38121 - Kubota |
| 2 | 38123 - Kubota |
| 3 | 38125 |
| 4 | 38126 |
| 5 | 38127 |
| 6 | 38128 |

| ITEM | PART NUMBER |
|------|---------------|
| 7 | 38129 (8') |
| 8 | 38131 (8') |
| 9 | 38133 (8') |
| 10 | 38135 (8') |
| 11 | 38122 - Deutz |
| 12 | 38124 - Deutz |
| 13 | 38130 (6') |
| 14 | 38132 (6') |
| 15 | 38134 (6') |

| ITEM | PART NUMBER |
|------|-------------|
| 16 | 38136 (6') |

Hydraulic Schematic #1, Main Propel Drive Version 3

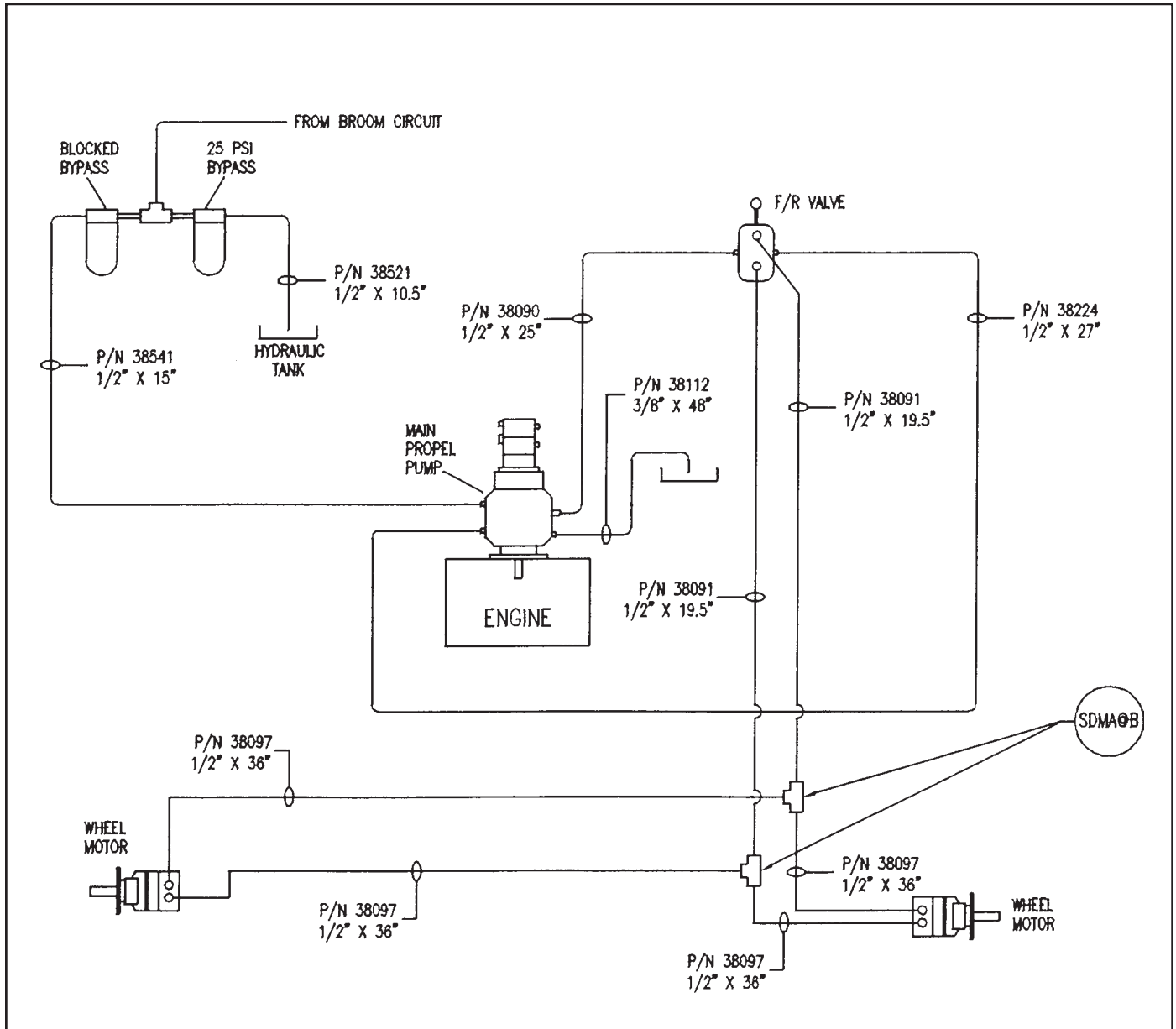

Hydraulics

Hydraulic Schematic #2, Steering / Auxiliary Version 3

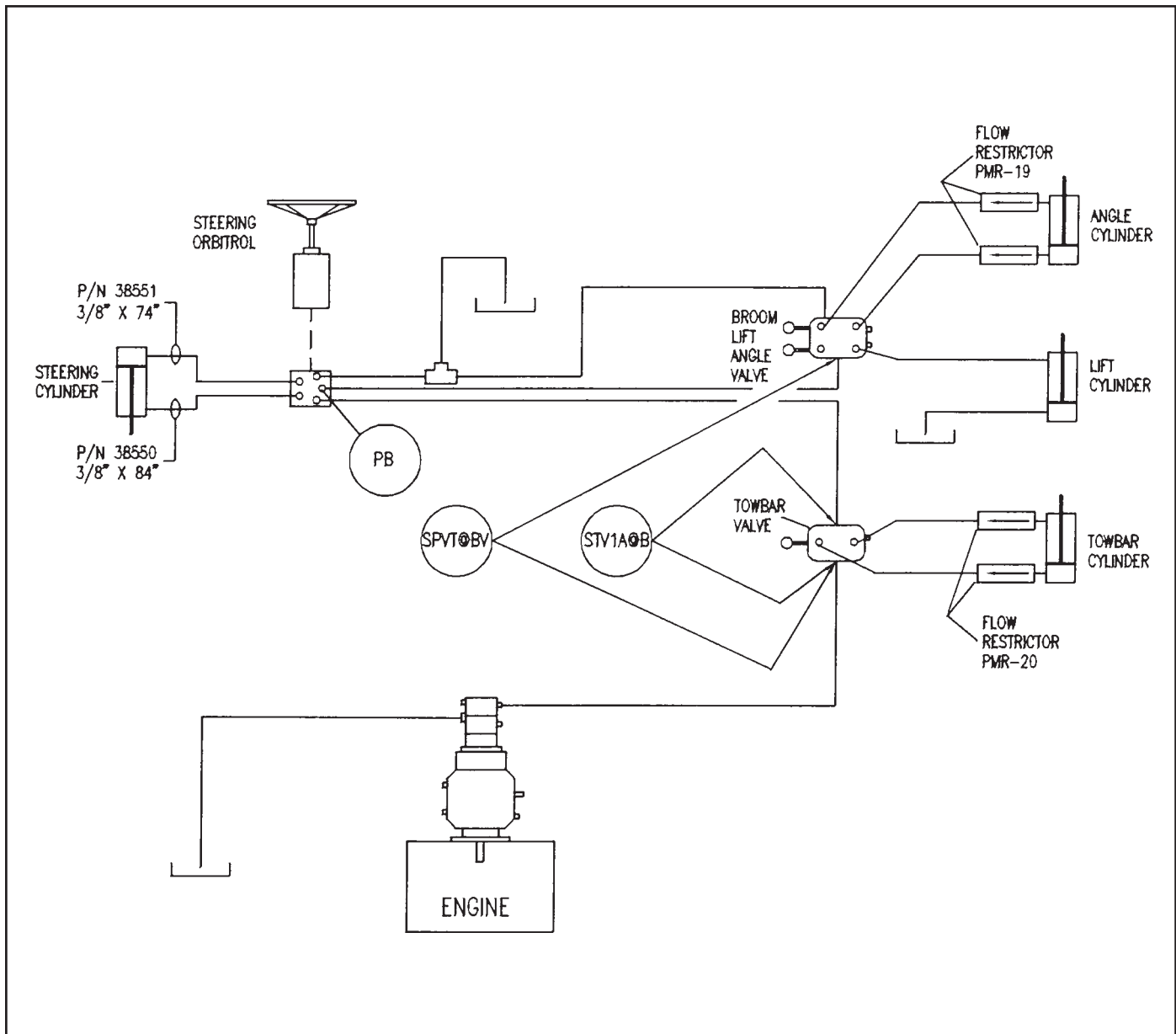

| ITEM | PART NUMBER |
|------|-------------|
| A | 38051 |
| B | 38087 |
| C | 38026 |
| D | 38015 |
| E | 38017 |
| F | 38016 |
| G | 38018 |
| H | 38020 |
| I | 38081 |

| ITEM | PART NUMBER |
|------|----------------|
| J | 38105 |
| 1 | 38108 - Kubota |
| 2 | 38106 |
| 3 | 38107 |
| 4 | 38108 |
| 5 | 38109 |
| 6 | 38110 |
| 7 | 38111 |
| 8 | 38112 |

| ITEM | PART NUMBER |
|------|---------------|
| 9 | 38473 |
| 10 | 38091 |
| 11 | 38115 |
| 12 | 38116 |
| 13 | 38117 |
| 14 | 38091 |
| 15 | 38119 - Deutz |

Hydraulic Schematic #3, Broom Drive Version 3

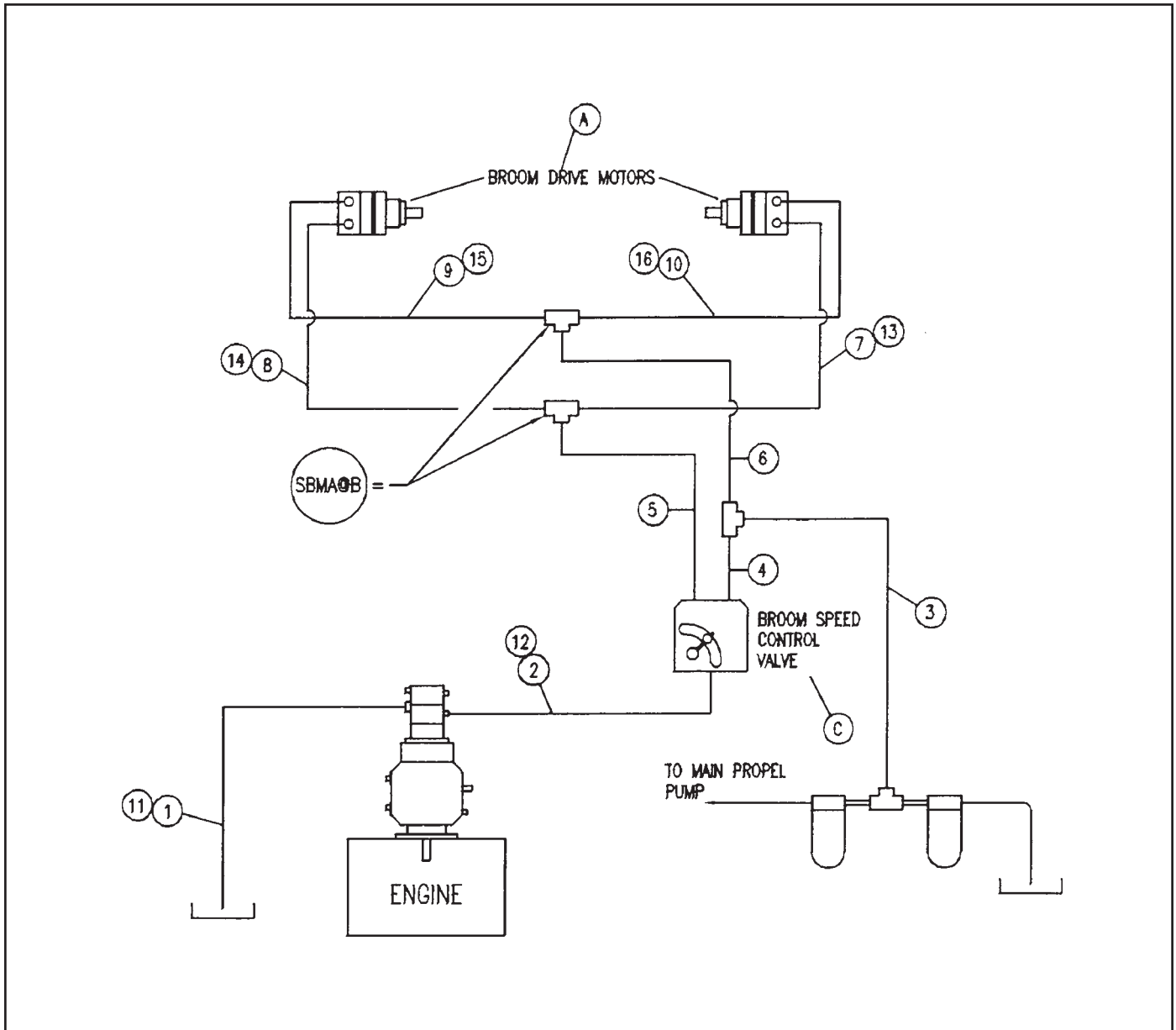

| ITEM | PART NUMBER |
|------|----------------|
| A | 38052 |
| B | 38081 |
| C | 38082 |
| 1 | 38121 - Kubota |
| 2 | 38123 - Kubota |
| 3 | 38125 |
| 4 | 38126 |
| 5 | 38127 |
| 6 | 38128 |

| ITEM | PART NUMBER |
|------|---------------|
| 7 | 38129 (8') |
| 8 | 38131 (8') |
| 9 | 38133 (8') |
| 10 | 38135 (8') |
| 11 | 38122 - Deutz |
| 12 | 38124 - Deutz |
| 13 | 38130 (6') |
| 14 | 38132 (6') |
| 15 | 38134 (6') |

| ITEM | PART NUMBER |
|------|-------------|
| 16 | 38136 (6') |

Wiring Diagram for DIODE Engine

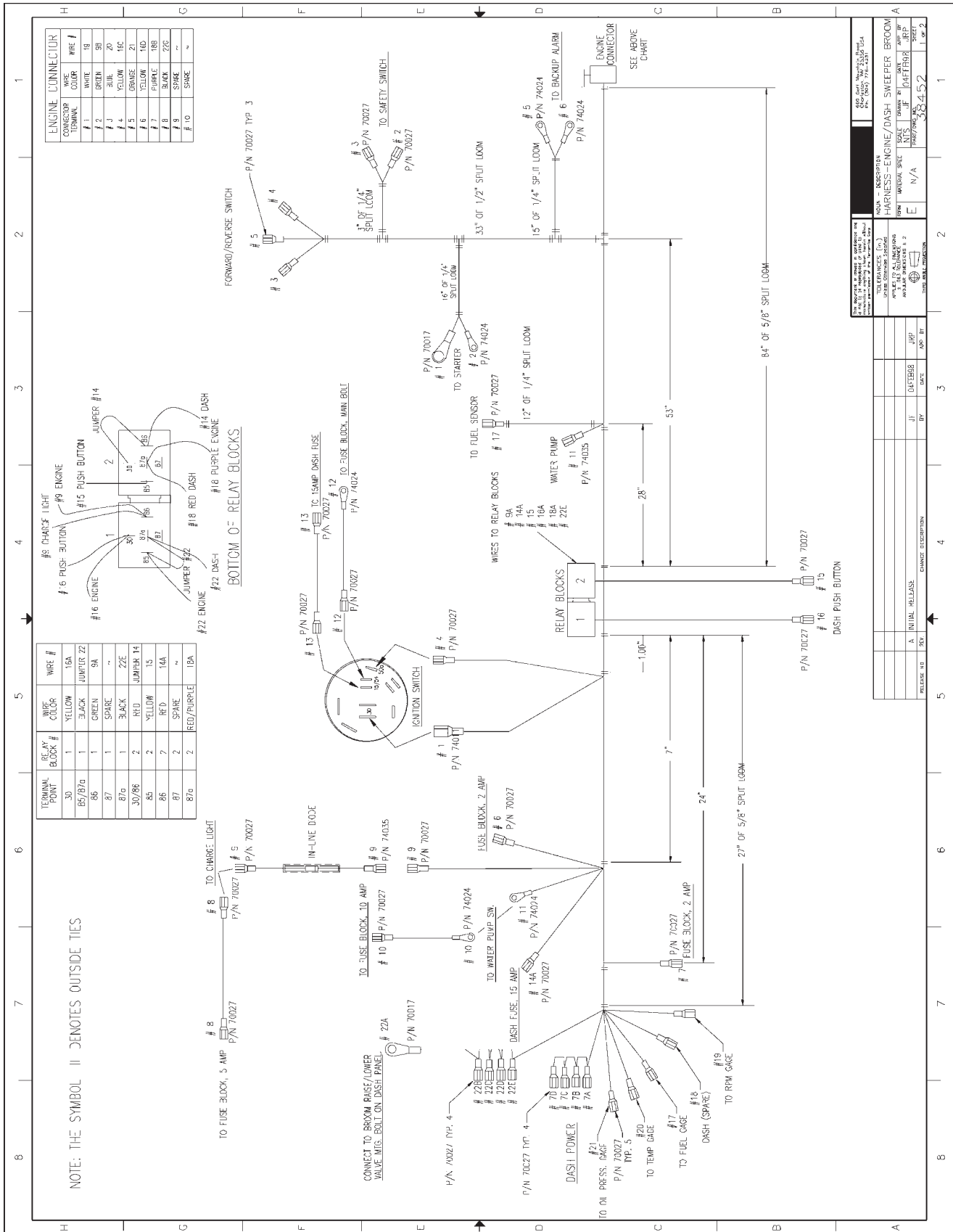

| RELEASE NO. | REV. | DATE | BY | APP. BY | DESCRIPTION |
|-------------|------|------|----|---------|-----------------|
| | A | | | | INITIAL RELEASE |
| | JF | | | | DAT/EBB JRP |
| | | | | | CHANGES |
| | | | | | DATE |
| | | | | | APP. BY |
| | | | | | DESCRIPTION |

| MANUFACTURER | SCALE | DATE | APP. BY | DESCRIPTION |
|--------------|-------|------|---------|-------------|
| TERRAMITE | 1:1 | | | |
| | | | | |
| | | | | |
| | | | | |
| | | | | |

| TERMINAL POINT | WIRE # | WIRE COLOR |
|----------------|--------|------------|
| 30 | 16A | YELLOW |
| 85/87a | ~ | BLACK |
| 86 | 9A | GREEN |
| 87 | ~ | SPARE |
| 30/86 | 22E | BLACK |
| 85 | 14 | RED |
| 86 | 13 | YELLOW |
| 87 | 14A | RED |
| 87a | 18A | RED/PURPLE |

Wiring Diagram Cat Engine

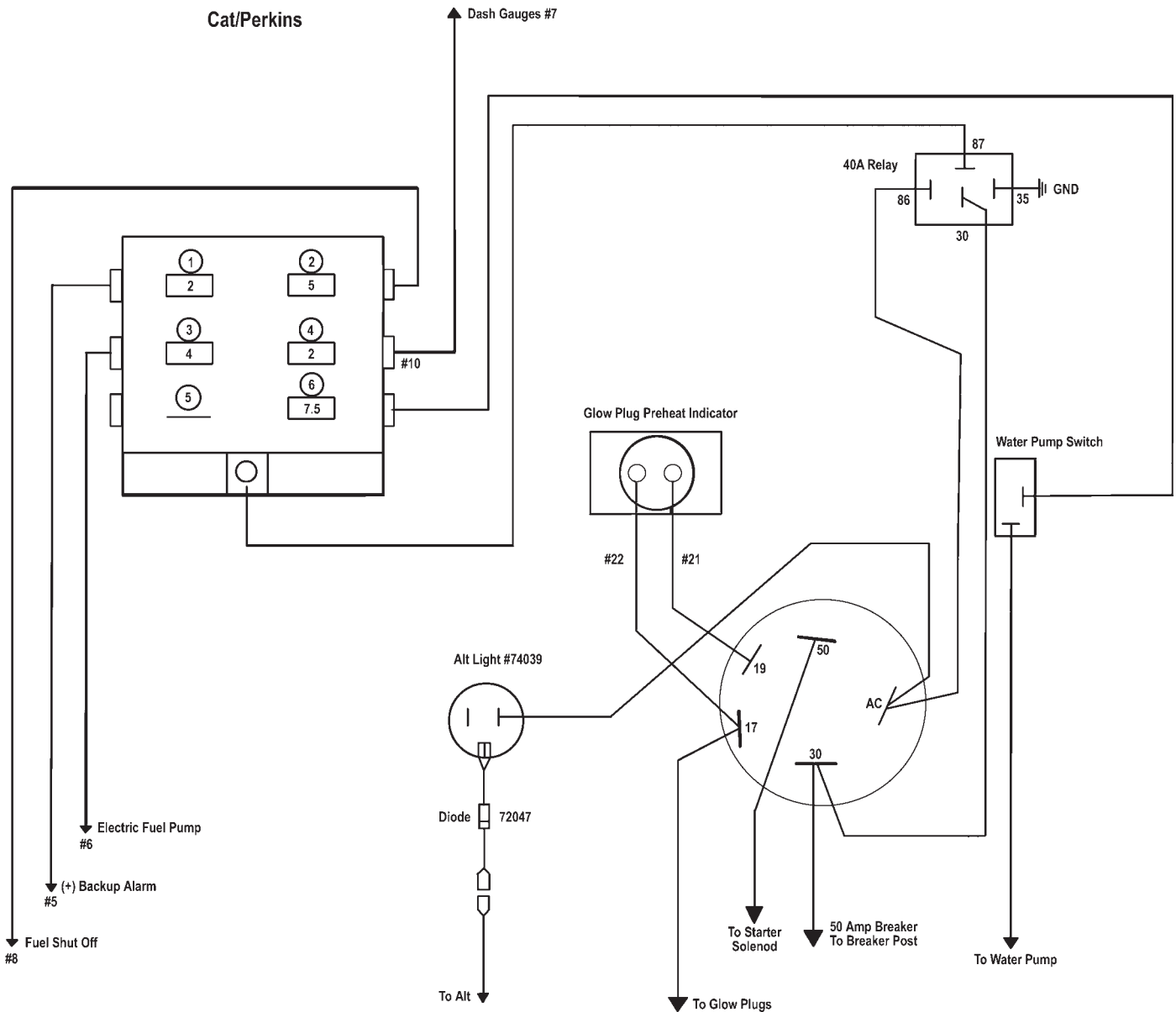

Wiring Diagram Cat Engine

Cat/Perkins Sweeper Wiring

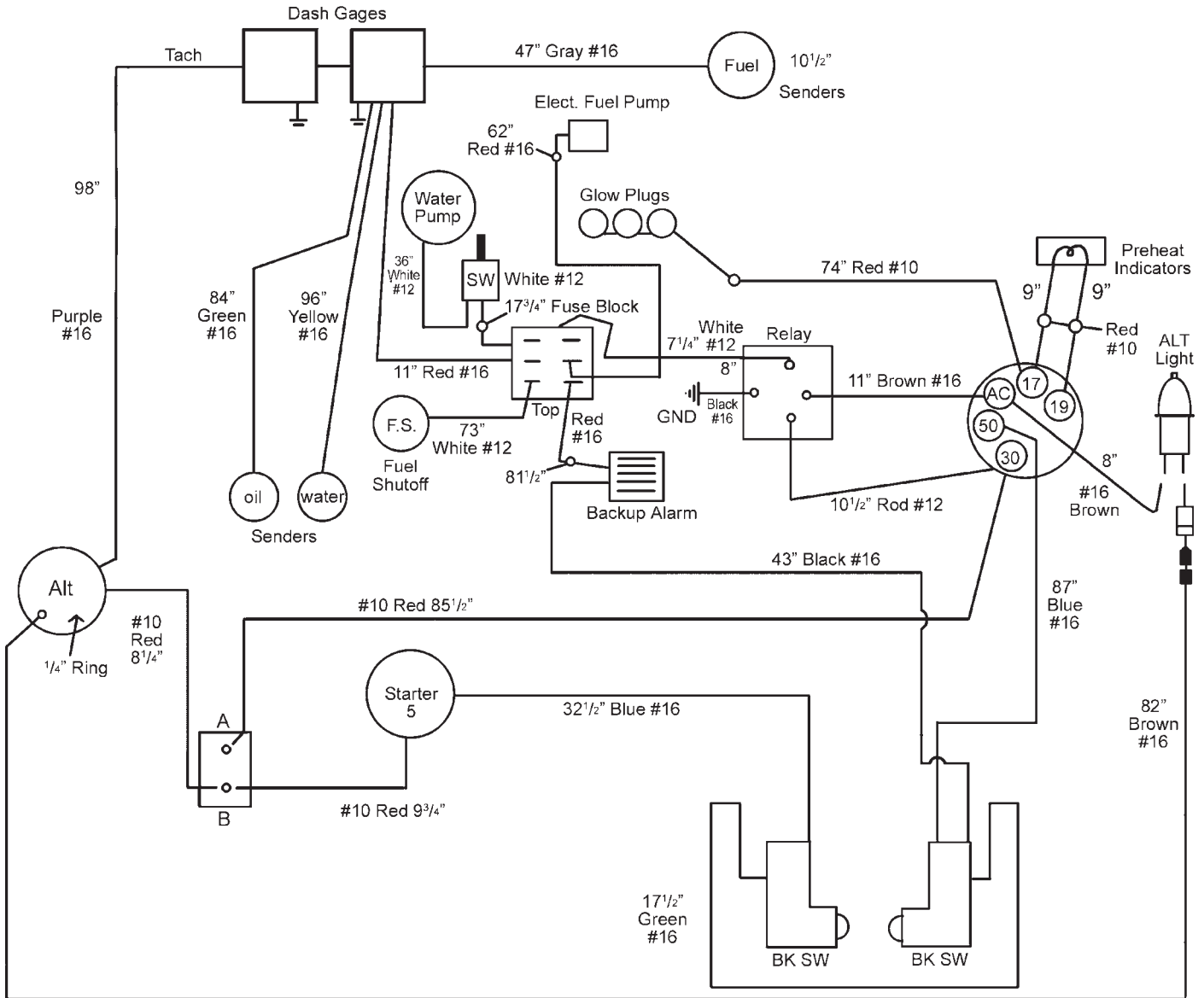

Wiring Diagram Cat Engine

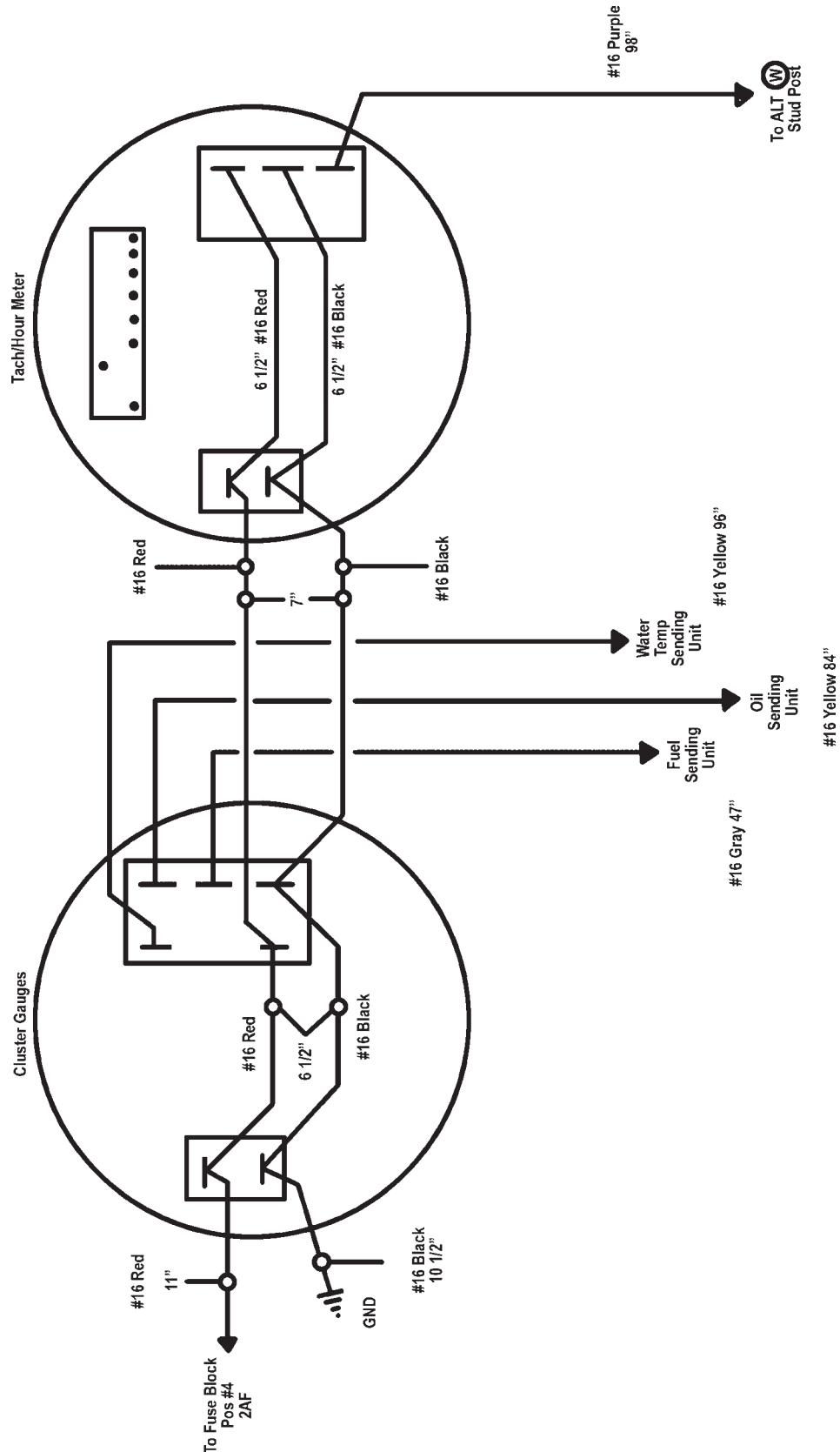

Wiring Harness Diagram for the Kubota Engine

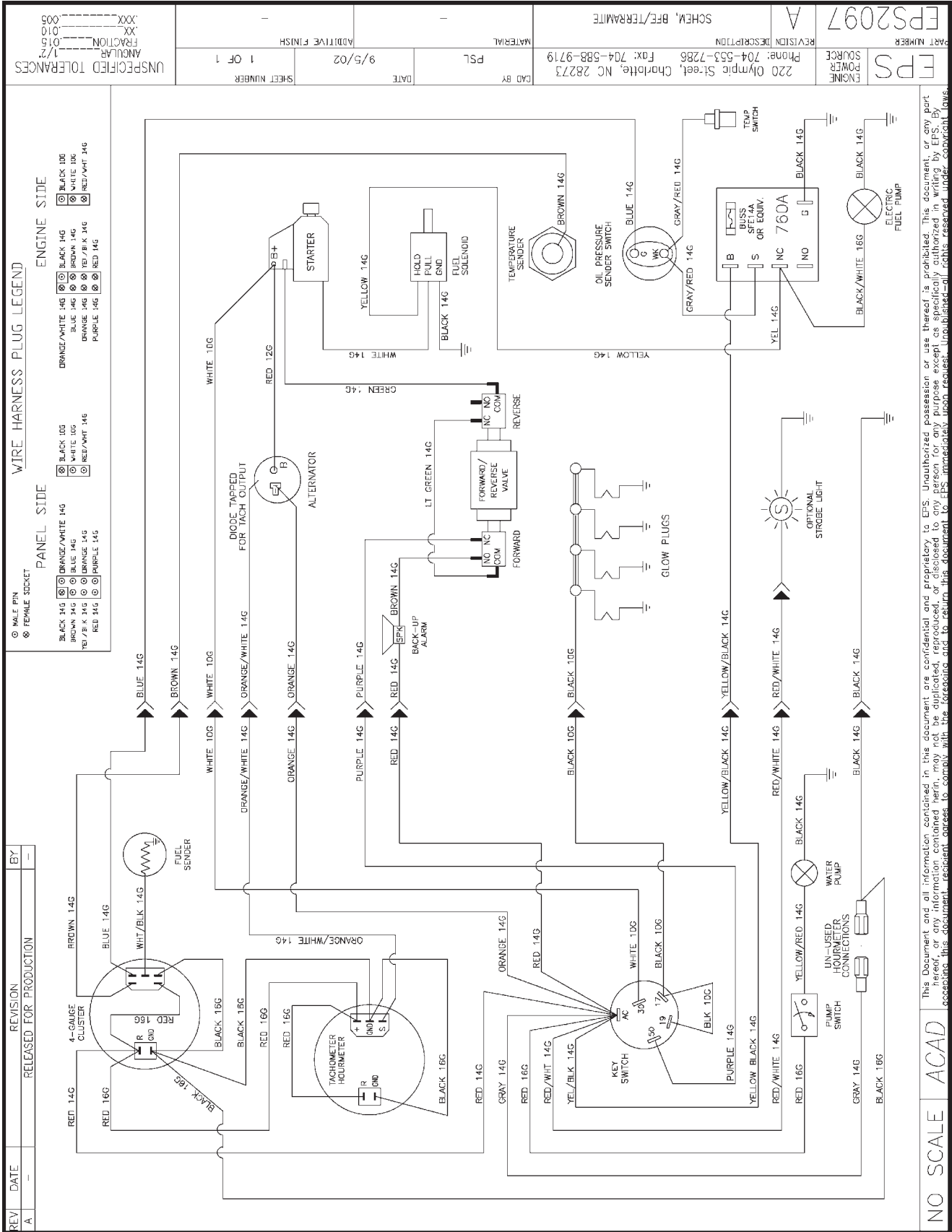

This Document and all information contained in this document are confidential and proprietary to EPS. Unauthorized possession or use thereof is prohibited. This document, or any part hereof, or any information contained herein, may not be duplicated, reproduced, or disclosed to any person for any purpose except as specifically authorized in writing by EPS. By accepting this document, customer agrees to comply with the conditions and to return this document to EPS immediately upon request. Unpublished rights reserved under copyright laws.

NO SCALE ACAD

Wiring Schematic Elec. Gauge Panel

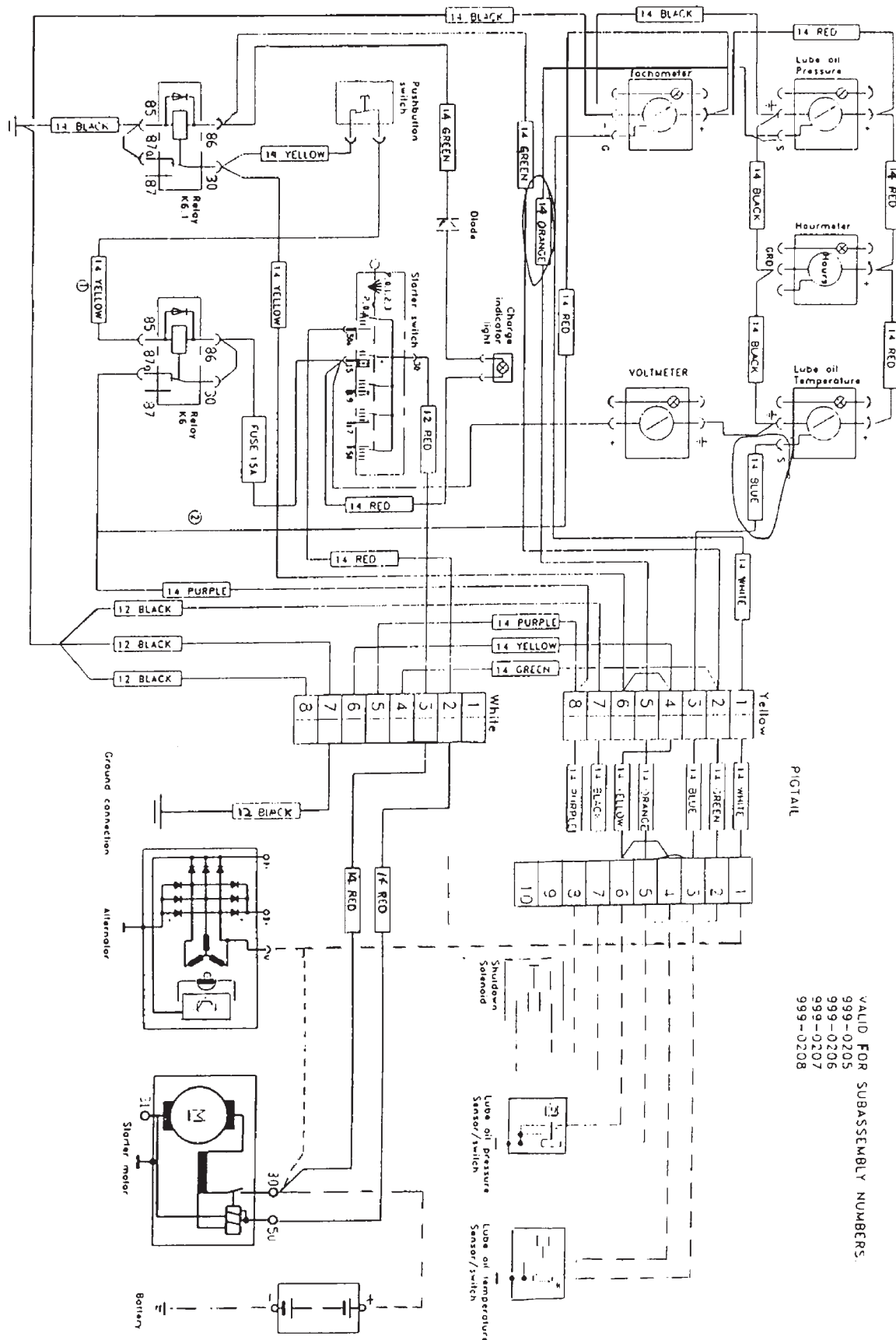

VALID FOR SUBASSEMBLY NUMBERS:
 999-0205
 999-0206
 999-0207
 999-0208

Decal Location - Right Side from Operators Position

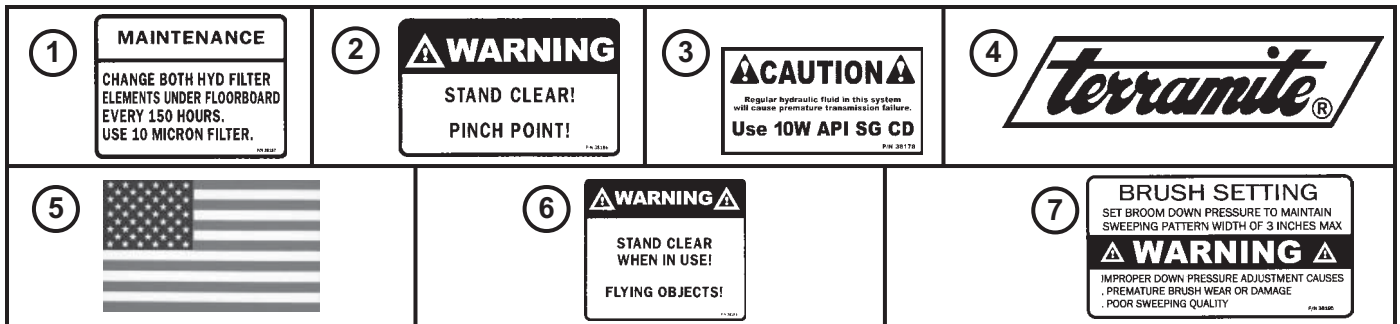
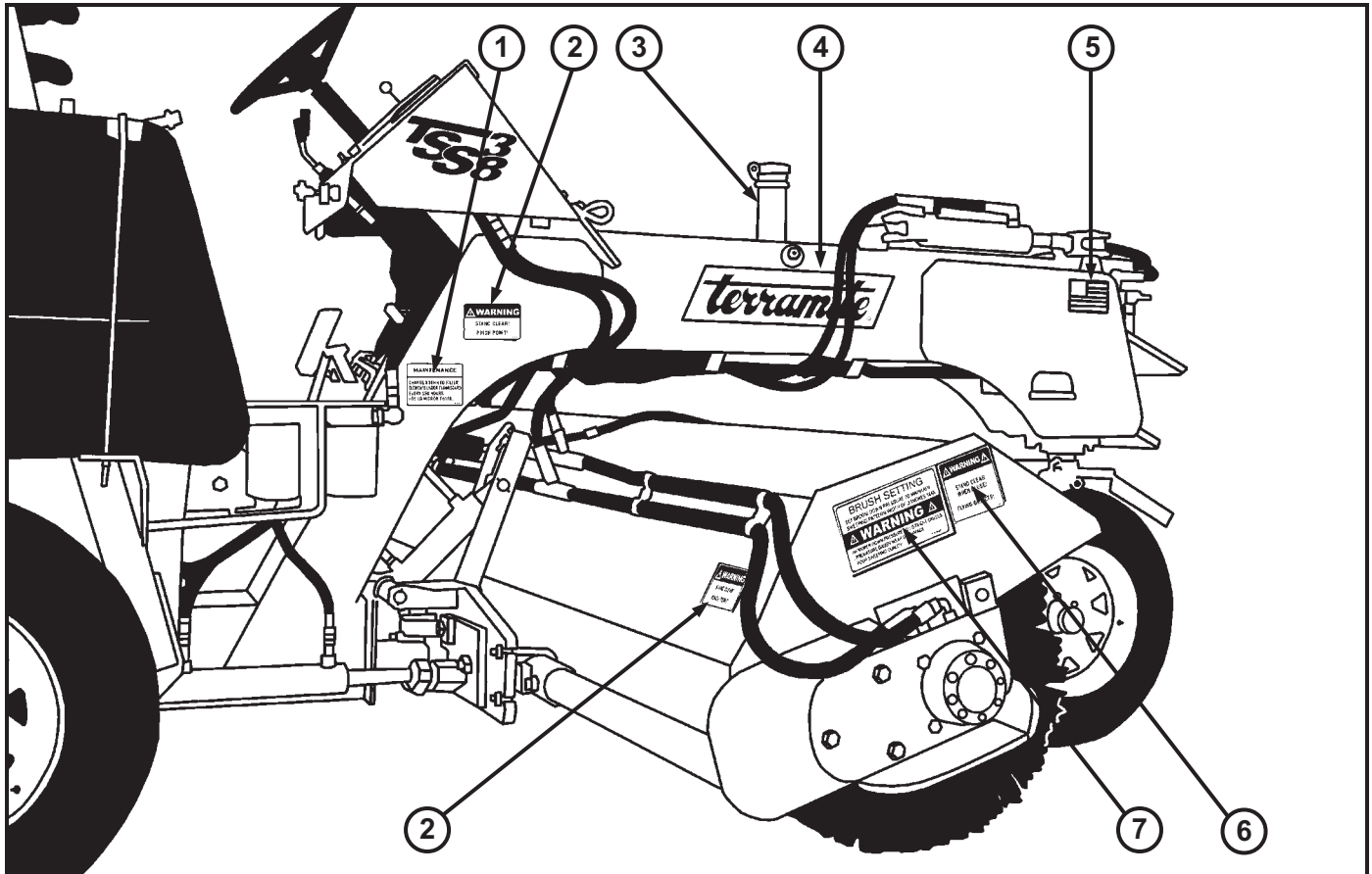

| ITEM | PART NUMBER | DESCRIPTION | QTY. |
|------|-------------|--|------|
| 1 | 38187 | Decal, Maintenance, Sweeper | 1 |
| 2 | 38186 | Decal, WARNING, Stand Clear Pinch Point, Sweeper | 6 |
| 3 | 38178 | Decal, Use 10W API SG CD, Sweeper | 1 |
| 4 | 14001 | Decal, Terramite, Sweeper | 2 |
| 5 | 14099 | Decal, American Flag, Sweeper | 2 |
| 6 | 38193 | Decal, WARNING, Stand Clear, Flying Objects, Sweeper | 4 |
| 7 | 38195 | Decal, WARNING, Brush Setting, Sweeper | 2 |

Decals

Decal Location - Left Side from Operators Position

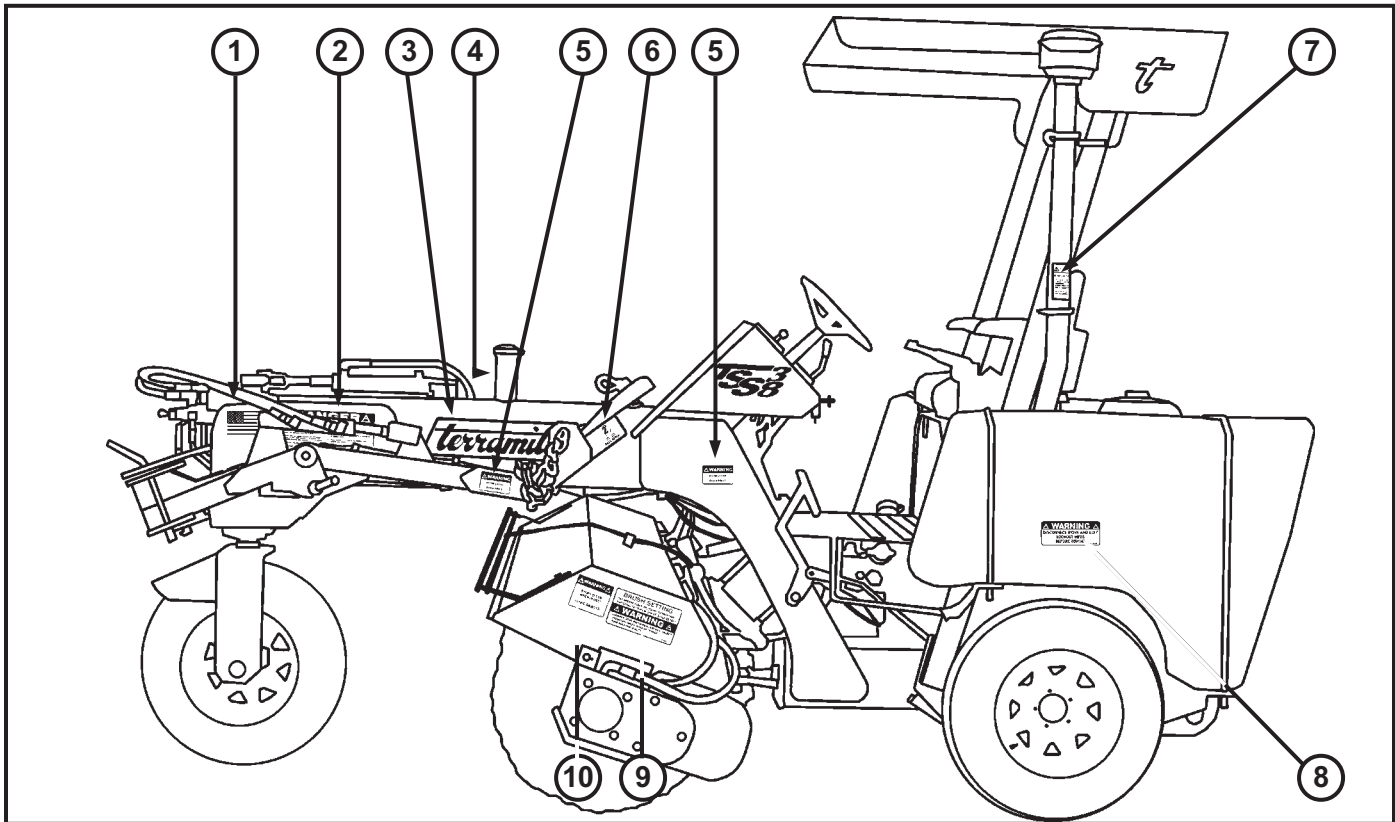

| | | | | |
|-----------------------------------|---|--|---|---|
| <p>1</p> | <p>2</p> <p>TOWING INSTRUCTIONS</p> <ol style="list-style-type: none"> 1. Set parking brake & turn off engine. 2. Pin tongue in towing position & connect hitch to towing vehicle. 3. Attach safety chain & hook up light cord. 4. Disconnect right & left lockout hubs. 5. Release parking brake before towing. <p><small>PN 38194</small></p> | <p>3</p> | <p>4</p> <p>CAUTION</p> <p>Regular hydraulic fluid in this system will cause premature transmission failure.</p> <p>Use 10W API SG CD</p> <p><small>PN 38178</small></p> | <p>5</p> <p>WARNING</p> <p>STAND CLEAR!</p> <p>PINCH POINT!</p> <p><small>PN 38186</small></p> |
| <p>6</p> <p>BALL HITCH</p> | <p>7</p> <p>CAUTION</p> <p>DO NOT USE ETHER</p> <p>ANY USE OF ETHER OR STARTING FLUID WILL PERMANENTLY DAMAGE ENGINE AND VOID ALL WARRANTY.</p> <p>USE GLOW PLUGS ONLY AS STARTING AID.</p> <p><small>PN 38185</small></p> | <p>8</p> <p>WARNING</p> <p>DISCONNECT RIGHT AND LEFT LOCKOUT HUBS BEFORE TOWING</p> <p><small>PN 38499</small></p> | <p>9</p> <p>BRUSH SETTING</p> <p>SET BRUSH DOWN PRESSURE TO MAINTAIN SWEEPING PATTERN WIDTH OF 3 INCHES MAX</p> <p>WARNING</p> <p>IMPROPER DOWN PRESSURE ADJUSTMENT CAUSES</p> <ul style="list-style-type: none"> • PREMATURE BRUSH WEAR OR DAMAGE • POOR SWEEPING QUALITY <p><small>PN 38195</small></p> | <p>10</p> <p>WARNING</p> <p>STAND CLEAR WHEN IN USE!</p> <p>FLYING OBJECTS!</p> <p><small>PN 38193</small></p> |

| ITEM | PART NUMBER | DESCRIPTION | QTY. |
|------|-------------|---|------|
| 1 | 14099 | Decal, American Flag, Sweeper | 2 |
| 2 | 38194 | Decal, Towbar Connection Instructions, Sweeper | 1 |
| 3 | 14001 | Decal, Terramite, Sweeper | 2 |
| 4 | 38178 | Decal, Use 10W API SG CD, Sweeper | 1 |
| 5 | 38186 | Decal, WARNING, Stand Clear, Pinch Point, Sweeper | 6 |
| 6 | 38482 | Decal, 2" Ball Hitch, Sweeper | 1 |
| 7 | 38185 | Decal, CAUTION, Do Not Use Ether, Sweeper | 1 |
| 8 | 38499 | Decal, WARNING, Disconnect Right and Left Lockout Hubs, Sweeper | 4 |
| 9 | 38195 | Decal, WARNING, Brush Setting, Sweeper | 2 |
| 10 | 38193 | Decal, WARNING, Stand Clear, Flying Objects, Sweeper | 4 |

Decal Location - Right Side from Operators Position

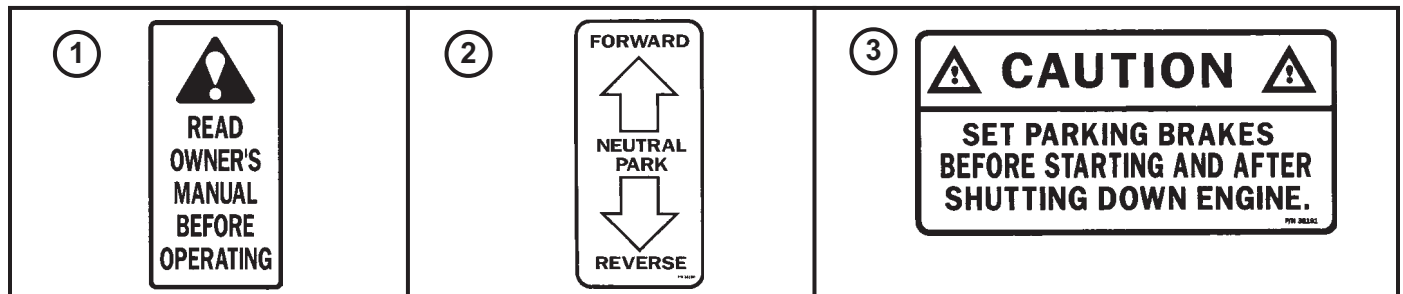
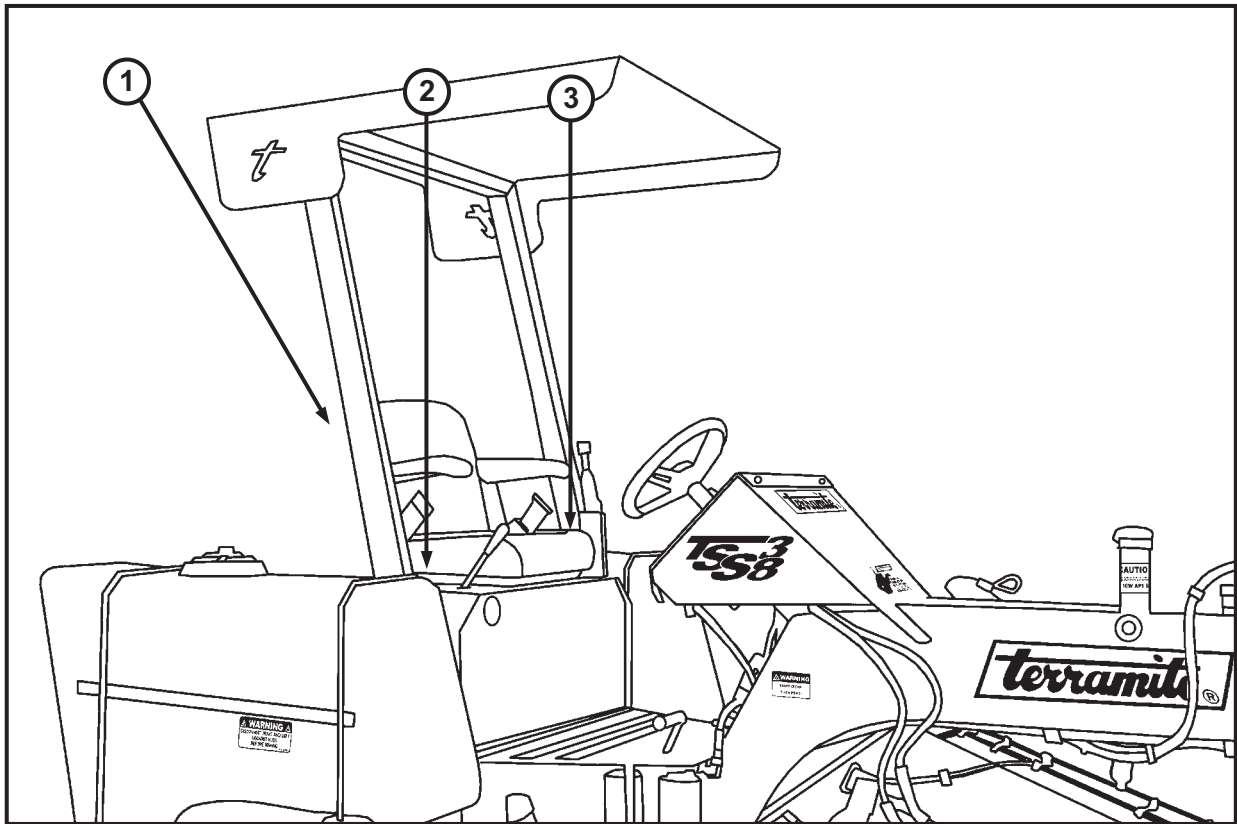

| ITEM | PART NUMBER | DESCRIPTION | QTY. |
|------|-------------|--|------|
| 1 | 14207 | Decal, Read Owner's Manual Before Operating, Sweeper | 1 |
| 2 | 38180 | Decal, Forward/Neutral/Park/Reverse, Sweeper | 1 |
| 3 | 38191 | Decal, CAUTION, Set Parking Brakes....., Sweeper | 1 |

Decals

Decal Location - Tow Bar

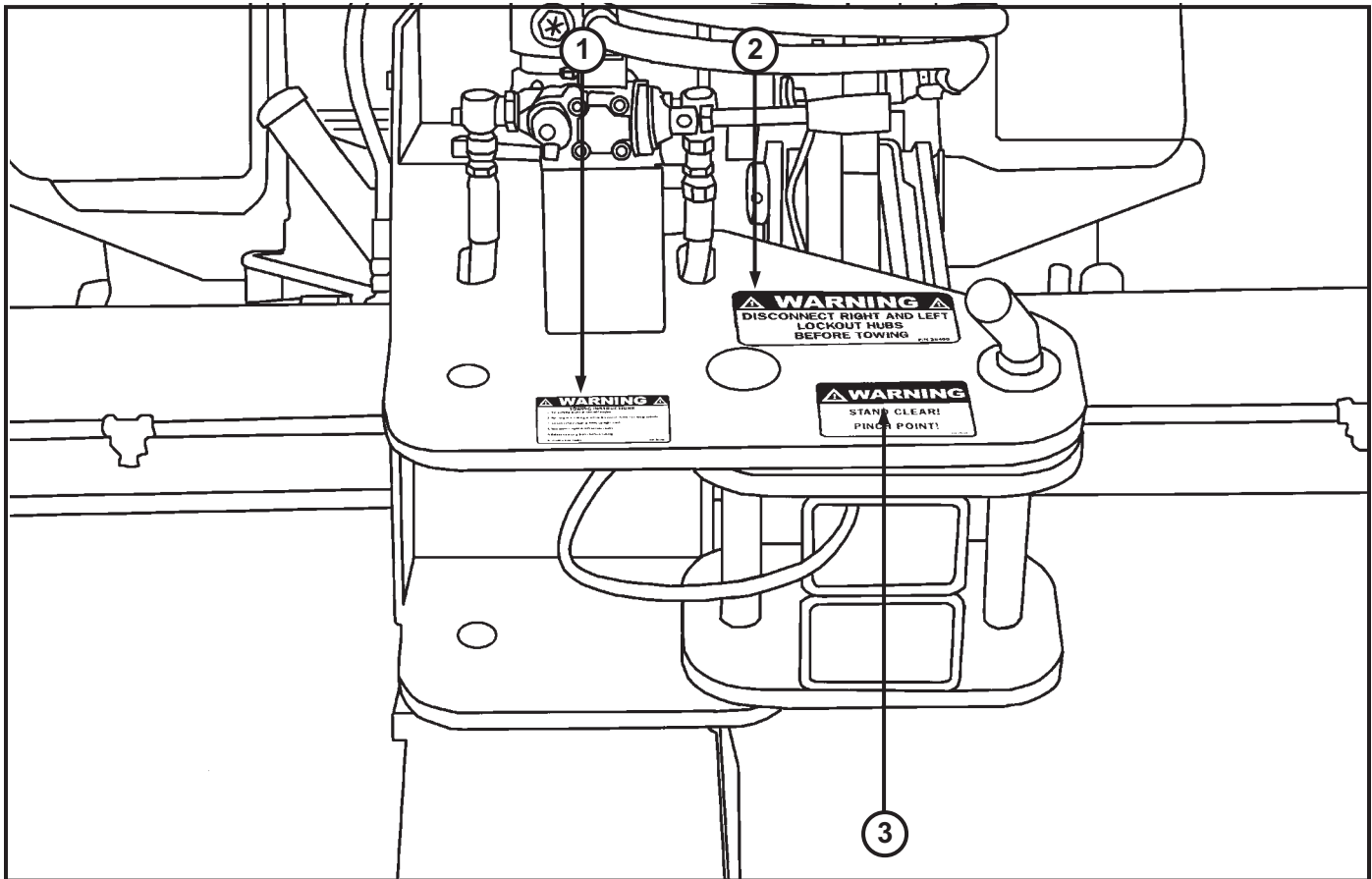

| ITEM | PART NUMBER | DESCRIPTION | QTY. |
|------|-------------|---|------|
| 1 | 38194 | Decal, WARNING, Towing Instructions, Sweeper | 1 |
| 2 | 38499 | Decal, WARNING, Disconnect Right and Left Lockout Hubs, Sweeper | 4 |
| 3 | 38186 | Decal, WARNING, Stand Clear Pinch Point, Sweeper | 6 |

Decal Location - Dash

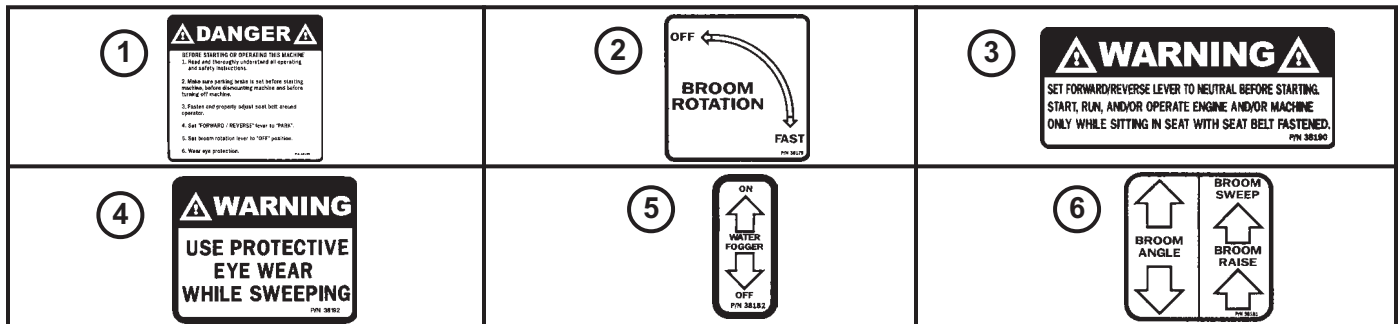
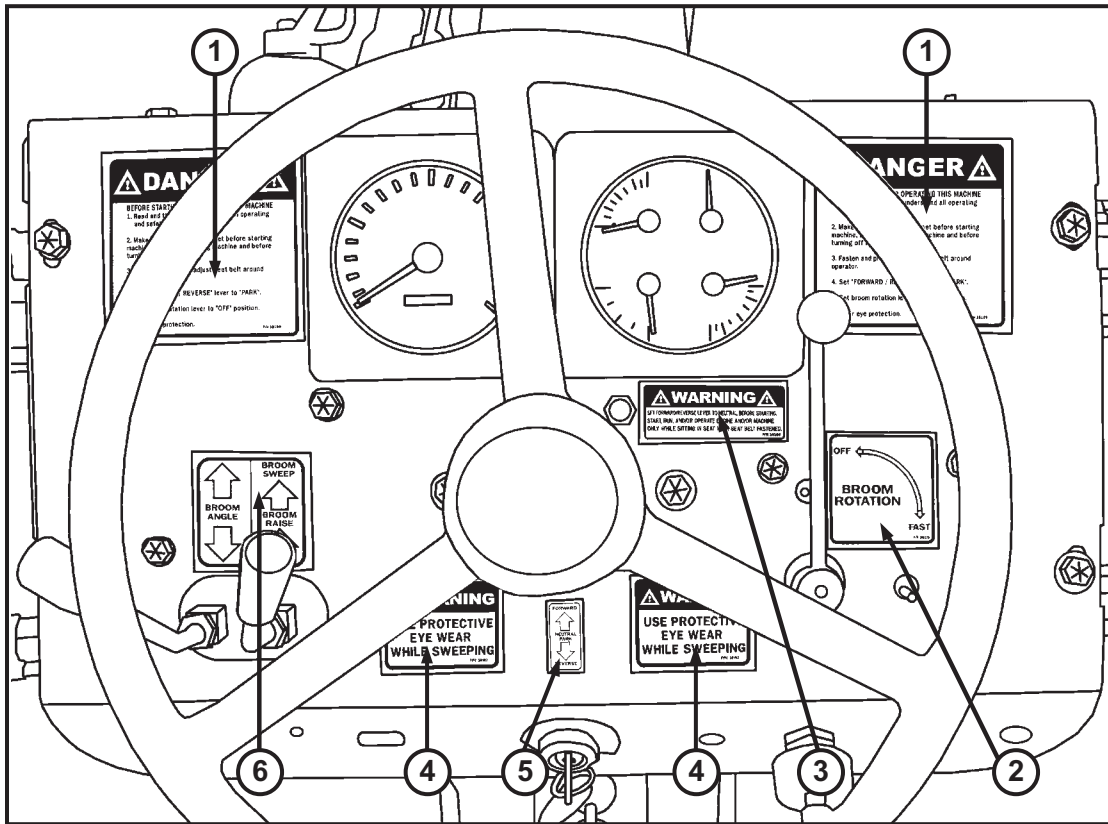

| ITEM | PART NUMBER | DESCRIPTION | QTY. |
|------|-------------|--|------|
| 1 | 38189 | Decal, DANGER, Before Starting This Machine...., Sweeper | 2 |
| 2 | 38179 | Decal, Broom Rotation, Sweeper | 1 |
| 3 | 38190 | Decal, WARNING, Set Forward/Reverse Lever..., Sweeper | 1 |
| 4 | 38192 | Decal, WARNING, Use Protective Eye Wear, Sweeper | 2 |
| 5 | 38182 | Decal, On/Water/Fogger/Off, Sweeper | 1 |
| 6 | 38181 | Decal, Broom Angle, Sweeper | 1 |

Decals

Terramite Suggest Keeping a Current Journal on Replacement Parts for Quick Reference or Field Notes on Your Machine

Lined area for journaling replacement parts and field notes.



Remember to Read, Understand and Follow Your Operator's Handbook on Safety and the Correct Procedure for Safe Operation and Handling of Your Street Sweeper

Translation Chart

| ENGLISH | FRANÇAIS | DEUTSCH | ESPAÑOL |
|----------------------|-------------------------|------------------------------------|----------------------|
| adapter | adaptateur | Zwischenstück | adaptador |
| arm | bras | Arm | brazo |
| axle assembly | essieu ensemble | Achse vollst | eje conjunto |
| axle shaft | arbre d'essieu | Achsenwelle | barra eje |
| bearing | palier | Lager | cojinete |
| body | carrosserie | Karosserie | carrocería |
| body assembly | ens carrosserie | Karosserie vollst | conj carrocería |
| bolt | boulon | Bolzen | bulón |
| boom | flèche | Hubarm | aguilón |
| boot | capuchon | Kappe | capuchón |
| bracket | support | Winkel | grampa |
| brake head assembly | étrier frein ens | Bremskopf vollst | cabeza freno conj |
| brake lever assembly | ens levier trein | Bremsebel vollst | conj planca freno |
| brake shoe | patin frein | Bremsschuh | zapata freno |
| breather | reniflard | Entlüse | carcasa |
| bucket | godet | Schaufel | cucharón |
| bushing | chemise | Buchse | buje |
| button | bouton | Knopf | botón |
| cable | câble | Kabel, Seil | Cable |
| cam | came | Nocke | leva |
| cap | chapeau | Kappe | tapa |
| carburetor | carburateur (mélangeur) | Vergaser | carburador |
| case | carter | Gehäuse | caja |
| chain | chaînes | Kette | cadena |
| Channel | canal, moulure | U-Träger, Profil | perfil |
| choke | enrichisseur | Starterklappe | ahogador |
| circuit breaker | disjoncteur | Unterbrecher | disyuntor |
| circuit | circuit | Stromkreis | circuito |
| clamp | attche, collier | Klammer, Einspannbacke | abrazadera |
| cleaner | épurateur | Luftreiniger | filtro |
| clevis | chape | Gabelkopf | horquilla |
| clip | agrafa | Klemme, Bügel | fbroche |
| collar | collier | Bundring, Flansch | collar |
| column | montant, colonne | Säule | columna de dirección |
| cone | cône, bague intérieure | Konus, Kegel | cónico |
| connecting | de liaison | verbinden | conectar |
| connection | connexion | Verbindungsstück, | conexión |
| connector | raccord | Anschluss, Stecker | conector |
| control | commande | Steuerung, Betätigung | control |
| converter | convertisseur | Drehmomentwandler | convertidor |
| cotter pin | goupille fendu | Splint | chaveta |
| counterweight | contrepoids | Gegengewicht | contrapeso |
| coupler | raccord | Anschlussstück, Schnellwechsler | conector, enganche |
| coupling | accouplement | Verbindungsstück | acoplamiento |
| cover | couvercle | Deckel | cubierta, tapa |
| crankcase | carter moteur | Kurbelgehäuse | cárter |
| crankshaft | vilebrequin | Kurbelwelle | cigüeñal |
| crosshead | traverse | Kreuzkoph | cruceta |
| cup | coupelle | Aussenring, Schale | taza |

Translations

Translation Chart (Continued)

| ENGLISH | FRANÇAIS | DEUTSCH | ESPAÑOL |
|------------------|------------------------|---|--------------------------|
| cushion | coussin | Dämpfungselement, Sitzpolster, Vollgummi | amortiguador |
| cylinder | cylindre | Zylinder | cilindro |
| cylinder block | bloc-cylindres | Motorblock, Zylinder- block | bloque de motor |
| decals | décalque, décalcomanie | Abziehbild, Beschriftung | calcomania |
| detachable | amovible | abnehmbar, geteilt | separable |
| differential | différentiel | Differential | diferencial |
| diode | diode | Diode | diodo |
| dipstick | jauge baïonnette | Messstab | varilla medidora |
| direction switch | inverseur de marche | Richtungsschalter | interruptor de direccion |
| directional | de sens de marche | richtungsabhängig | sentido de marcha |
| disc | disque | Scheibe | disco |
| distributor | allumeur | Verteiler, Zündverteiler | distribuidor |
| divider | diviseur, répartiteur | Teller, Verteiler | divisor |
| dowel | goujon | Passstift, Haltestift | espiga |
| drive axle | essieu moteur | Antriebsachse | eje motriz |
| drum | tambour | Trommel | tambor |
| dual | jamelé, double | doppelt, zweifach | doble |
| elbow | coude | Kniestück, Winkelstück | codo |
| element | élément | Element, Einsatz | elemento |
| enclosure | carter, carénage | Umrandung, Gehäuse | compartimiento |
| end | terminal, extrémité | Ende | extremo |
| engine | moteur | Motor | motor |
| exhaust | échappement | Auspuff | escape |
| extension | prolongement, rollonge | Verlängerung | extensión |
| exhaust valve | souparpe d'échappement | Auspuff-, Auslassventil | válvula de escape |
| fan | ventilateur | Lüfter | ventilador |
| felt | feutre | Filz | anillo de retén |
| fender | aile, pare-boue | Schutzblech, Kofflülge | guardabarros |
| film | film, autocollant | Aufkleber | película |
| filter | filtre | Filter | filtro |
| fitting | graisseur, raccord | Nippel, Schraubverbindung | acoplamiento |
| flap | rabat, bavette | Felgenreand, Klappe | pestaña |
| flasher | clignotant | Blinkgeber | contacto intermitente |
| flash lamp | ampoule de clignotant | Blinkleuchte | bombilla intermitente |
| float | flotteur | gleiten, schwimmen | flotador |
| floor | sol, plancher | Boden | piso |
| flow | débit, courant, flux | Strömung, Durchfluss | flujo |
| flywheel | volant (moteur) | Schwungrad | volante |
| flow protector | protecteur de débit | Durchfluss-Schutzvorrichtung | protector de flujo |
| foot | pied | Fuss | pie |
| fork | fourche | Gabel | horquilla |
| forward | en avant | vorwärts | adelante, hacia adelante |
| frame | châssis | Rahmen | bastidor |
| front | avant | vorne, Front | frente, parte delantera |
| fuel | carburant | Kraftstoff | combustible |
| FFTL | triple levée | Dreifach-Vollfreihub | alto despejo libre |
| fuse | fusible | Sicherung | fusible |
| gasket | joint | Dichtung | junta |

Translation Chart (Continued)

| ENGLISH | FRANÇAIS | DEUTSCH | ESPAÑOL |
|--------------|----------------------------------|-------------------------|--|
| guage | jauge | Anzeiger | medidor, indicador, calibrador |
| gear | pignon, engrenage | Zahnrad, Gang | engranaje |
| glow plug | bougie de préchauffage | Glühkerze | bujía incandescente |
| grommet | virole | Tülle, Dichtungsring | arandela aislante |
| group | ensemble | Gruppe, Satz | grupo |
| guard | protecteur | Schutz, Abdeckung | protector |
| guide | guide | Führung | guía |
| hand brake | frein à main | Handbremse | freno de emergencia |
| handle | poignée | Griff, Handgriff | asa |
| harness | faisceau | Kabelbaum, Verdrahtung | mazo de cables |
| head | tête | Kopf | culata |
| head lamp | phare AV | Scheinwerfer | luz delantera |
| height | hauteur | Höhe | altura |
| hinge | charnière | Gelenk, Scharnier | bisagra |
| hold down | tendeur | Aufspannvorrichtung | sujetador |
| holder | support | Halter | soporte |
| hood | capot | Motorhaube | capó |
| hook | crochet | Zughaken | gancho |
| horn | avertisseur | Hupe, Signalhorn | bocina |
| hose | durite, flexible | Schlauch | manguera |
| housing | boîtier, carter | Gehäuse | caja |
| hub | moyeu | Nabe, Radnabe | maza |
| hydraulic | hydraulique | Hydraulik | hidráulico |
| ignition | allumage | Zündung | encendido |
| indicator | indicateur | Anzeigevorrichtung | indicador |
| injection | injection | Einspritzung | inyección |
| injector | injecteur | Einspritzventil | inyector |
| inner | intérieur | innen | interior |
| insert | pièce rapportée | Einsatz | inserto |
| instrument | instrument | Instrument | instrumento |
| insulation | isolation | Isolierung | aislante |
| insulator | isolateur | Isolator, Nichtleiter | aislador |
| intake valve | soupape d'admission | Ansaugventil | válvula de admisión, válvula de aspiración |
| interface | surface de réparation, interface | Übertragungseinheit | entrecara, zona Interfacial |
| jacket | chemise, jupe | Mantel, Wärmeisolierung | camisa, chaqueta |
| intermediate | intermédiaire, moyen | indirekt | intermedio, medianero |
| joint | joint | Gelenk, Verbindung | junta, unión, juntaura |
| keeper | détente | Gegenmutter, Halter | tirante, fijader, retentór |
| key | clé, clavette | Schlüssel, Keil | llave |
| lever | levier | Hebel | palanca |
| leveler | niveleur, correcteur | Planierer | nivelador |
| light | lumière | Leuchte | luz |
| line | canalisation | Leitung | tuberia |
| liner | chemise, garniture | Laufbuchse | camisa |
| lining | revêtement, garniture (frein) | Auskleidung, Belag | revestimiento, forro |
| link | baillette, maillon | Glied, Gelenkstück | eslabón |
| locknut | contre-écrou | Kontermutter, Siche- | tuerca de traba |

Translations

Translation Chart (Continued)

| ENGLISH | FRANÇAIS | DEUTSCH | ESPAÑOL |
|-----------------|---------------------------------|---|-----------------------------------|
| | | rungsmutter | |
| lockwasher | rondelle d'arrêt | Federring | arandela de seguridad |
| magnet | aimant | Magnet | imán |
| manifold | collecteur | Krümmer | múltiple |
| master cylinder | maître-cylindre | Hauptzylinder | cilindro maestro |
| maximum | maximum | maximal | máximo |
| meter | instrument, mètre | Messgerät | medidor, dosificador |
| modulating | de modulation | Modulation | modulador |
| motor | moteur | Motor, elektr. | motor |
| mount | support | anbauen, montieren | montar |
| mounting | montage | Befestigung, Anbausatz | montaje |
| muffler | silencieux d'échappement | Schaildämpfer | silenciador |
| nipple | graisseur | Schmiernippel | boquilla |
| nut | écrou | Mutter | tuerca |
| oil | huile | Öl | aceite |
| oil level | niveau d'huile | Ölstand | nivel del aceite |
| outer | extérieur | aussen | exterior |
| oil filter | filtre à huile | Ölfilter | filtro de aceite |
| O-ring | joint torique | O-Ring | sello anular |
| oversize | surdimensionné, majoré | Übermass, Übergrösse | sobremedida |
| packing | garniture d'étanchéité | Abdichtung | empaquetadura |
| pad | tampon, coussin | Polster, Unterlagsblock | almohadilla |
| pan | carter, cuvette | Ölwanne | colector del cárter |
| panel | tableau | Verkleidungsblech, Instrumentenbrett | panel, tablero de instrumentos |
| pedal | pédale | Pedal | pedal |
| pin | goupille, axe | Bolzen, Stift | pasador |
| pinion | pignon | Ritzel | piñón |
| piston | piston | Kolben | pistón |
| pivot | pivot | Anlenk-, Drehpunkt, Auf- hängung | pivote |
| plate | plaque, plateau | Platte, Blech | placa, plancha |
| plug | bouchon | Schraubstopfen | tapón, bujía |
| plunger | plongeur | Tauch-, Ventilkolben | émbolo |
| polished | poli | poliert | pulido |
| precleaner | préfiltre | Vorreiniger | antefiltro |
| primary | primaire | Haupt-, Vor-, primär | primario |
| priority | priorité, séquence | Sicherheits-, Vorrang | prioridad |
| protector | protecteur | Schutzvorrichtung | protector |
| pulley | pulie | Riemenscheibe | polea |
| pump | pompe | Pumpe | bomba |
| push rod | poussoir | Schubstange | varilla de empuje |
| race | chemin de roulement, cuvette | Lager-, Laufring | anillo de cojinete |
| radiator | radiateur | Kühlernetz | radiador |
| rail | rail (glissière) | Schiene | riel, mástil |
| rear | arrière, AR | rückwärts, hinten | posterior, trasero |
| rectifier | redresseur | Gleichrichter | rectificador |
| regulator | régulateur | Regler, Reguliervorrichtung | regulador |
| relay | relais | Relais | relé |

Translation Chart (Continued)

| ENGLISH | FRANÇAIS | DEUTSCH | ESPAÑOL |
|--------------------|-------------------------------|--------------------------|---|
| relief valve | soupape de décharge | Überdruckventil | válvula de alivio |
| repair | réparation | Reparatur | reparación |
| required (Reqd.) | requis | erforderlich | requerido |
| reservoir | réservoir | Tank | depósito, tanque |
| retainer | arrêtoir | Halterung | retén |
| reverse | marche AR | Rückwärtsgang | marcha atrás, reverso |
| right hand (RH) | côté droit, à droit | rechts | lado derecho (L.D.) |
| ring | anneau, joint | Ring | anillo, aro, argolla |
| rivet | rivet | Niete | remache |
| rocker arm | culbuteur | Kipphebel | balancin |
| rod | bielle | Stange, Pleuelstange | varilla |
| roller | galet | Laufrolle | rodillo |
| rotor | rotor | Rotor, Laufrad | rotador, rotor, rodete |
| seal | joint | Dichtring | sello |
| seal-o-ring | joint torique | O-Ring-Dichtung | anillo, anillo de estancamiento |
| sealant | produit d'étanchéité | Dichtungsmittel | sellante, sellador |
| seal-u-cup | joint en demi-lune | U-Profil-Dichtungsring | copa en "U" |
| seat | siège | Sitz | asiento |
| secondary | secondaire | Anbau-, Hilfs-, Sekundär | secundario, auxiliar |
| sender | émetteur, sonde | Geber (Kraftstoffstand) | sensor |
| sending unit | émetteur | Messwertgeber | unidad sensora |
| separator | séparateur | Separator, Abscheider | separador |
| setscrew | vis de fixation | Gewindestift | tornillo de traba, tornillo prisionero |
| shaft | arbre, axe | Welle | eje, mango largo, rastágo |
| shield | bouclier, écran de protection | Abdeckung, Schild | protector |
| shim | cale de réglage | Beilagscheibe | calce |
| short block | bloc-moteur nu | Teil-, Skelettmotor | bloque de motor sin accesorio, bloque parcial |
| shroud | panneau, plaque | Abdeckplatte | cubierta, refuerzo de ventilador |
| sideshift | déport latéral | Seitenschubvorrichtung | desplazador lateral |
| sleeve | manchon, chemise | Büchse, Hülse | manguito |
| snap | jonc d'arrêt | Sprengring | anillo de presión, cierre de resorte |
| socket | douille, chape | Fassung | enchufe |
| solenoid | solénoïde | Magnetspule | solenoide |
| spacer | entretoise | Distanzstück | espaciador |
| spark plug | bougie d'allumage | Zündkerze | bujía |
| spider | croisillon | Gelenkkreuz | cruceta |
| spindle | pivot, fusée, broche | Spindel, Achszapfen | punta de eje |
| spool | tiroir | Ventilstößel | carrete |
| springs | ressort | Feder | resortes |
| sprocket | barbotin | Antriebsrad | rueda dentada |
| standard (Std.) | normal | Standard | estándar |
| starter | démarrreur | Anlasser | arranque |
| stationary (Stat.) | stationnaire | Aussenmast, stationär | estacionario, inmóvil |
| stator | stator | Ständer, Stator | estator |

Translations

Translation Chart (Continued)

| ENGLISH | FRANÇAIS | DEUTSCH | ESPAÑOL |
|-----------------|--------------------------------------|-----------------------------------|-------------------------|
| steering | directon | Lenkung | dirección |
| stem | tige | Schaft | vóstago |
| strainer | filtre, crépine | Sieb | filtro |
| strap | sangle | Riemen, Gurt | banda, correa |
| strut | étai, tirant | Strebe | tirante de dirección |
| stud | goujon, tenon | Stehbolzen | espárrago |
| support | support | Auflager, Abstützung | soporte |
| switch | interrupteur | Schalter | interruptor |
| tag | étiquette | Anhänger | etiqueta |
| tapered | conique | konisch, kegelförmig, verjüngt | perfil cónico, aguzado |
| tappet | poussoir | Anschlag, Stößel | levantaválvulas |
| tee | té | T-Stück | conexión "T" |
| terminal | borne | Anschlussklemme | terminal |
| thermistor | thermistor | Thermistor, Temperatur- fühler | termistor |
| thermostat | thermostat | Thermostat | termostato |
| tightner | tendeur | Spanner | tensor, ajustador |
| tilt cylinder | vérin d'inclinaison | Neigezylinder | cilindro de inclinación |
| tire | pneumatique | Reifen | neumático |
| transfer | déclacomane, autocollant | Abziehbild | transferencia |
| transmission | transmission, boîte de vi- tesses | Getriebe | transmisión |
| tread-step | marchepied | Triffstufe | estribo antirresbalante |
| tube | tuyau, tube, gicleur | Rohr, Schlauch | tubo |
| tubing | canalisations | Rohr, Schlauchleitung | tuberias, tubos |
| undersize | sous-dimensionne, minore | Untermass | bajomedida |
| union | raccord | Anschlusstück, Verbinaung | unión |
| universal joint | cardan | Kreuzgelenk | junta universal |
| upright | montant | senkrecht, Hubgerüst | montante vertical |
| valve | soupape, clapet | Ventil | válvula |
| valve mechanism | culbuterie | Ventilsteuerung | mecanismo de válvulas |
| vacuum | vide, dépression | Vakuum, Unterdruck | vacio, vacuómetro |
| washer | rondelle | Unterlegscheibe | aradela |
| water | eau | Wasser | agua |
| water pump | pompe à eau | Wasserpumpe | bomba de agua |
| wear strip | bande d'usure | Verschleissstreifen | plancha de desgaste |
| wheel | roue | Rad | rueda |
| wheel cylinder | cylindre de roue | Radbremszylinder | cilindro de rueda |
| wiper | racleur | Wischer, Abstreifer | limpiaparabrisas |
| wire | fil | Draht, Leitung | alambre, cable |
| wire harness | faisceau de fils | Kabelbaum | mazo de cables |
| wire marker | marquer de fil | Kabelmarkierung | marcador de alambre |
| worm | vis sans fin | Schnecke | tornillo sin fin |
| wrap | revêtement, enveloppe | Hülle | envolver, envoltura |
| yoke | chape | Gabelgelenk, Joch | horquilla |

A

| | |
|-----------------------------|----------------------|
| Alarm, Back-Up | 3.26 |
| Arm, Steering | 3.8 |
| Arm, Welded Pump | 3.25 |
| Assembly: | |
| Brake/Disconnect | 3.27 |
| Engine | 3.23 |
| Filter, High Pressure | 3.26 |
| Rod Brake Pedal | 3.16 |
| Tire & Wheel | 3.2, 3.9, 3.10, 3.11 |
| Transmission/Pump | 3.25 |

B

| | |
|--|------------------|
| Bar, Brush Mount | 3.2, 3.35 |
| Bar, Spray | 3.11, 3.12, 3.14 |
| Battery | 3.22, 3.23 |
| Bearing, 4 Bolt Flange, Front Fork | 3.6, 3.8, 3.9 |
| Belt, Seat | 3.21 |
| Bolt: | |
| 1/2 x 1" GR8 | 3.15 |
| 1/2 x 2 1/4" GR8 | 3.25 |
| 1/2 x 3 1/4" GR8 | 3.8 |
| 1/2 - 13 x 1 1/2" NC GR8Z | 3.9 |
| 5/8 x 2 1/4" GR8Z | 3.6 |
| Eye, 3/8 - 16 x 2" | 3.24 |
| Eye, Brake Extension Spring | 3.3 |
| Shoulder, Pedal, 3/4 - 10 x 4" NC | 3.16 |
| Boot, Forward/Reverse Valve | 3.10 |
| Bracket, Seat Belt Mounting | 3.21 |
| Bracket, Tail Light Harness | 3.22 |

Brake Hub:

| | |
|--|------------|
| Backing Plate | 3.41 |
| Basic Hypac | 3.41 |
| Bearing & Race, Inner #14 & #15, Set | 3.40 |
| Bearing & Race, Outer #2 & #3, Set | 3.40 |
| Bolt, Wheel Hub | 3.41 |
| Brake Arm Shaft Assembly | 3.41 |
| Brake/Disconnect Hub Assembly | 3.41 |
| Brake Shoe | 3.41 |
| Brake Shoe Assembly | 3.41 |
| Gasket, Face Seal "A" Mount 4 Bolt | 3.41 |
| Handle, Shaft | 3.40 |
| Housing w/Brake | 3.40 |
| Hub - Drum | 3.41 |
| Key, 0.312 sq. x 1" Long | 3.40 |
| Locknut | 3.40, 3.41 |
| Lock Washer, Inner | 3.40, 3.41 |
| Ret. Ring - Handle | 3.40 |
| Ret. Ring - Shaft | 3.40 |
| Ret. Ring - Sleeve | 3.40 |
| Ret. Ring - Spring | 3.40 |
| Seal, Oil - Bearing | 3.40 |
| Seal, Oil, Shaft | 3.40 |
| Shaft | 3.40 |
| Sleeve, Brake Disconnect Hub | 3.40 |
| Spindle, Brake, Disconnect Hub | 3.40, 3.41 |
| Spring | 3.41 |
| Spring, Shaft | 3.40 |
| Steel Drum | 3.41 |
| Washer, Spring | 3.40 |
| Washer, Tongued | 3.40 |
| Wrench, Hypac Hub Mount Hub | 3.41 |

Broom:

| | |
|--|------|
| Bolt, 1/2" - 13 x 1 1/2" | 3.27 |
| Bolt, 3/4" - 10 x 3" | 3.34 |
| Dust Cap | 3.32 |
| Flat Washer SAE, 1/2" | 3.27 |
| Flat Washer SAE, 3/4" | 3.34 |
| Flat Washer USS, 3/4" | 3.34 |
| Kit P/N - Bearings, Hub and Dust Cap | 3.32 |
| Lock Nut, 3/4" | 3.34 |
| Lock Washer, 1/2" | 3.27 |
| Mount Plate w/Stops | 3.34 |
| Nut, 1/2 - 13, Heavy Hex | 3.31 |
| Slotted Nut, P/N, 3/4" | 3.32 |
| Spindle, P/N | 3.32 |
| Washer, P/N, 3/4" SAE | 3.32 |

Broom, Core:

| | |
|----------------------------------|------|
| Bearing/Race | 3.32 |
| Body, 4 Bolt Thru Mounting | 3.50 |

Broom, Core (continued):

| | |
|--|------------|
| Cap, Plate | 3.31 |
| Cotter Pin, 1/8" x 1 3/4" | 3.32 |
| Ring | 3.50 |
| Rings, Thick | 3.31, 3.32 |
| Rings, Thin, Center | 3.31, 3.32 |
| Plate, End | 3.31 |
| Seal | 3.32 |
| Seal Kit, Drive Motor, Brush | 3.50 |
| Seal, O-Ring, Drive Motor, Brush | 3.50 |
| Seal/Retainer Assembly | 3.50 |
| Seal, Square Ring or Motor | 3.50 |
| Tube | 3.31, 3.32 |
| Washer, Thrust # 11 | 3.50 |
| Washer, Thrust Hard #13 | 3.50 |
| Washer, Thrust Drive Motor | 3.50 |

Brush Bar:

| | |
|------------------------------------|------|
| Bolt, 1/2" - 13 x 1" | 3.35 |
| Flat Washer SAE, 1/2" | 3.35 |
| Lock Nut, 1/2" - 20 | 3.35 |
| Long Pin, 1" Dia x 4 1/8" | 3.36 |
| Long Pin, 1" Dia x 5 1/8" | 3.36 |
| Long Roll Pin, 1/4" x 1 1/2" | 3.36 |
| U-Bolt, 1/2" x 3" x 6" | 3.35 |

Brush Core:

| | |
|-------------------------------------|------|
| 6 Foot | 3.38 |
| 8 Foot | 3.38 |
| Block Seal for Brush Motor | 3.38 |
| Bolt, 3/8" x 3/4" | 3.38 |
| Bolt, 1/2" - 13 x 1 1/2" | 3.37 |
| Bolt, 1/2" - 13 x 2 1/2" | 3.37 |
| Cap Plate | 3.38 |
| Drive Motor Block | 3.38 |
| Flat Head Bolt, 1/2" x 1 1/4" | 3.38 |
| Flat Washer SAE, 1/2" | 3.37 |
| Key Retainer Washer | 3.38 |
| Lock Nut, 1/2" | 3.37 |
| Lock Washer, 1/2" | 3.37 |
| Motor | 3.37 |
| Motor Mount, LH | 3.37 |
| Motor Mount, RH | 3.37 |
| Set Screw, 5/16" - 18 x 1/2" | 3.38 |
| Straight Key | 3.38 |
| Brush Hood, 6 Foot | 3.27 |
| Brush Hood, 8 Foot | 3.27 |
| Brush Lift Cylinder | 3.36 |

C

| | |
|---|-----------------------|
| Cable, Ground Strap, 12" Eye x Eye | 3.22 |
| Cable, Negative Battery | 3.22 |
| Cable, Positive Battery | 3.22 |
| Cable, Throttle | 3.17, 3.18 |
| Cap, Locking, Fuel/Hydraulic Filler | 3.8, 3.10, 3.11, 3.12 |
| Cap, Steering Wheel | 3.17 |
| Cap, Water Tank Fill | 3.8 |
| Chain, Safety, Tow-Bar | 3.4, 3.5 |
| Clamp, 19/32" Spray Orifice | 3.13, 3.14 |
| Clamp, Spray Bar to Push Lock Hose | 3.13, 3.14 |
| Clevis, Weldable, 5/16 - 24 | 3.27 |
| Coupler, Tow Bar Hitch, 2" | 3.4, 3.5 |
| Cylinder, Brush Angle | 3.2, 3.15 |
| Cylinder, Brush Lift | 3.15, 3.16 |
| Cylinder, Steering | 3.2, 3.8, 3.9, 3.11 |
| Cylinder, Tow-Bar Lift | 3.4, 3.5 |

D

Decal:

| | |
|--|----------|
| 2" Ball Hitch | 5.2 |
| American Flag | 5.1, 5.2 |
| Broom Angle | 5.5 |
| Broom Rotation | 5.5 |
| CAUTION, Do Not Use Ether | 5.2 |
| CAUTION, Set Parking Brakes | 5.3 |
| DANGER, Before Starting This Machine | 5.5 |
| Forward/Neutral/Park/Reverse | 5.3 |
| Maintenance | 5.1 |
| On/Water/Fogger/Off | 5.5 |
| Read Owner's Manual Before Operating | 5.3 |
| Terramite | 5.1, 5.2 |

INDEX

Decal (continued):

| | |
|---|---------------|
| Tow Bar Connection Instructions | 5.2 |
| Use 10W API SG CD | 5.1, 5.2 |
| WARNING, Brush Setting | 5.1, 5.2 |
| WARNING, Disconnect Right and Left Lockout Hubs | 5.2, 5.4 |
| WARNING, Set Forward/Reverse Lever | 5.5 |
| WARNING, Stand Clear, Flying Objects | 5.1, 5.2 |
| WARNING, Stand Clear, Pinch Point | 5.1, 5.2, 5.4 |
| WARNING, Towing Instructions | 5.4 |
| WARNING, Use Protective Eye Wear | 5.5 |

E

F

Filter:

| | |
|---|------------|
| Air | 3.23 |
| Base | 3.45 |
| Bolt 1/4" - 20 x 5/8 GR8Z | 3.45 |
| Bowl | 3.29 |
| Element | 3.29, 3.45 |
| Fitting, 1/2 mp x #8MVIC 90° | 3.45 |
| Fitting 3/4" mp x 1/2 F Reducer | 3.45 |
| Fitting, #8MVIC x #8MP Straight | 3.45 |
| Fitting, "T", mp Across 3/4 FP Center | 3.45 |
| Housing Assembly | 3.45 |
| Hydraulic | 3.9, 3.45 |
| "O" Ring | 3.29, 3.45 |
| Relief Nut Assembly | 3.45 |
| Suction, Water-Pump | 3.16 |

Fitting:

| | |
|---|------------------|
| 3/8 HBT 29 Brass, Waterline | 3.10 |
| 1/2 MP x #8MJIC90° | 3.15, 3.16, 3.18 |
| 1/2 MP x 3/8 HB90, Water Tank | 3.3 |
| 1 1/4 O-Ring x 1" JIC90° | 3.24 |
| #6 O-Ring Plug | 3.20 |
| #6 O-Ring x #6MJIC Straight | 3.20 |
| #6 O-Ring x #6MJIC90° | 3.25 |
| #6 O-Ring x #6MJIC90° w/.016, Cylinder Hose, Tow-Bar Lift | 3.4, 3.5 |
| #6 O-Ring x #6MJIC45° (Forged) | 3.20 |
| #6 O-Ring x #8MJIC45° (Forged) | 3.20 |
| #8MB O-Ring x #6JIC90°, Tow-Bar Valve | 3.5 |
| #8MJIC "T" | 3.18 |
| #8MJIC x #8MP Straight | 3.20 |
| #8MJIC x #10 O-Ring 90° w/Check P | 3.24, 3.25 |
| #8 O-Ring x #6JIC90°, Tow-Bar Valve | 3.5, 3.7 |
| #8 O-Ring x #6JICM45° | 3.20 |
| #8 O-Ring x #8JICM45° | 3.19, 3.20 |
| #8 O-Ring x #8MJIC | 3.24 |
| #8 Swivel Nut Run "T" | 3.19 |
| #12 O-Ring x #8MJIC | 3.24, 3.25 |
| #12 O-Ring x #8MJIC90° | 3.24 |
| 90° Water | 3.30 |
| Fuel Tank, 1/4FM x 1/4" FM90° | 3.16 |
| Hex Head, #8 Plug | 3.20 |
| "L" 1/4" | 3.24, 3.25 |
| Tee Brass Water | 3.30 |

Front Fork:

| | |
|-----------------------------|-----------|
| 4 Bolt Flange Bearing | 3.28 |
| Bolt, 1/2 | 3.28 |
| Bolt, 5/8 | 3.28 |
| Front Fork | 3.3, 3.28 |
| Lock Nut, 1/2 | 3.28 |
| Lock Nut, 5/8 | 3.28 |
| Washer, 1/2 | 3.28 |
| Washer, 5/8 | 3.28 |
| Steering Arm | 3.28 |
| Frame | 3.2 |

G

| | |
|--|-----------|
| Gauge, Fuel/Oil/Temp/Volts | 3.20 |
| Gauge, Hourmeter/Tachometer Cluster | 3.20 |
| Gear Pump, Key, Coupler, Cessna | 3.47 |
| Gear Pump, Kit, Seal, Double Gear Pump | 3.47 |
| Gear, Steering | 3.2, 3.20 |

Ground Drive:

| | |
|---|------|
| Bolt, 1/2" - 20 x 1/2" GR8 | 3.46 |
| Brake Hub Assembly | 3.46 |
| Gasket, Motor-to/Lockout, Wheel Drive | 3.46 |
| Motor, Drive, Wheel, w/Relief | 3.46 |
| Nut, Lug, 1/2" ID x 13/16" | 3.46 |
| Sleeve, Brake Disconnect Hub | 3.46 |
| Washer, 1/2", Split Lock | 3.46 |

H

| | |
|--------------------------------------|-----------|
| Handle, Brake | 3.2, 3.21 |
| Handle, Broom Lift/Angle Valve | 3.17 |
| Handle, Tow-Gar Valve | 3.7 |
| Harness, Electrical, Tow-Bar | 3.4, 3.7 |
| Head, Filter, Blocked-By-Pass | 3.15 |
| Head, Filter, 25PSI, Relief | 3.15 |
| Hold Down, Battery | 3.22 |
| Hood Assembly w/Lights | 3.22 |
| Hood, Engine | 3.22 |

Hose:

| | |
|--|-----------------------|
| #8FJIC x #8JICF90°, 6 Ft. Brush (L & R Side) | 3.13, 3.14 |
| #8FJIC x #8JICF90°, 8 Ft. Brush (L & R Side) | 3.13, 3.14 |
| 3/8", Push Lock | 3.15 |
| 3/8 x 4 | 3.29 |
| 3/8 x 9" | 3.29 |
| 3/8 x 12", HY06-06FJ-06FJ9 | 3.26 |
| 3/8 x 16" | 3.29 |
| 3/8 x 19" | 3.29 |
| 3/8 x 30", #6FJIC Both | 3.15, 3.19 |
| 3/8 x 31", #6FJIC Both, Cylinder, Tow Bar Lift | 3.4, 3.5, 3.8, 3.11 |
| 3/8 x 37", #6FJIC Both, Cylinder, Tow Bar Lift | 3.4, 3.5, 3.8, 3.11 |
| 3/8 x 48", #6FJIC Both | 3.9, 3.15, 3.18, 3.19 |
| 3/8 x 74", #6FJIC x #6FJIC90° | 3.9, 3.10 |
| 3/8 x 84", #6FJIC x #6FJIC90° | 3.9, 3.10, 3.11 |
| 3/8 x 92", #8FJIC x #6FJIC - Kubota | 3.7 |
| 3/8 x 96", #8 FJIC x #6FJIC - Deutz | 3.7 |
| 3/8 (Left) x 65" | 3.29 |
| 3/8 (Right) x 75" | 3.29 |
| 1/2 x 10 1/2", FX08W/hy08 | 3.18 |
| 1/2 x 12", #8FMJICSTR Both | 3.26 |
| 1/2 x 13", #8FJIC x #8FJIC90° | 3.19 |
| 1/2 x 19 1/2", #8FJIC x #8FJIC90° | 3.26 |
| 1/2 x 25", #8FJIC x #8FJIC45° | 3.26 |
| 1/2 x 25", #8FMJIC Both | 3.26 |
| 1/2 x 29", FX08W/hy08-08 FJ | 3.18 |
| 1/2 x 36", #8FJIC x #8JICF90° | 3.26 |
| 1/2 x 39", #8FJIC x #8JICF90° | 3.9, 3.18, 3.19 |
| 1/2 x 54", #8FJIC x #8FJIC90° | 3.9 |

J

K

| | |
|----------------------------|------|
| Key, Ignition | 3.18 |
| Kit, Front Hub | 3.10 |
| Kit, Tow-Bar Coupler | 3.4 |

L

| | |
|-----------------------------|------|
| Latch, Engine Hood | 3.22 |
| Lever, Brush Speed | 3.17 |
| Light, Stop/Turn/Tail | 3.22 |
| Link, Quick, 5/16" | 3.16 |

M

| | |
|-------------------------------|----------------|
| Motor, Brush Core Drive | 3.2, 3.9, 3.10 |
| Mount, Brush Core Motor | 3.13, 3.14 |
| Muffler | 3.23 |

N

| | |
|-----------------|------|
| New Gauge | 3.20 |
| New Kit | 3.17 |

O

P

| | |
|----------------------------------|------|
| Panel, Cover, Rear, Engine | 3.22 |
| Panel, Top, Engine | 3.21 |
| Pedal, Brake | 3.16 |

Pin:

| | |
|--|---------------------------|
| 1" x 2 1/8" Lg., Steering Cylinder | 3.15 |
| 1" x 4 1/2" Lg., Top Broom Lift | 3.15 |
| 1" x 5 1/8 Lg., Broom Lift | 3.15 |
| Linch, Tow-Bar Pivot Pin | 3.6 |
| Roll 1/4" x 1 1/2" | 3.15 |
| Tow-Bar | 3.5, 3.6, 3.7, 3.8, 3.12 |
| Tow-Bar Lift/Steering Cylinder | 3.4, 3.5, 3.8, 3.9, 3.11 |
| Tow-Bar - Lower Locking | 3.5, 3.11, 3.12 |
| Tow-Bar - Upper Locking | 3.5, 3.7, 3.8, 3.11, 3.12 |

| | |
|------------------------------|-----|
| Pipe, Air Inlet, Deutz | 3.2 |
|------------------------------|-----|

Pivot:

| | |
|--------------------------------|------|
| Bearing Weldment | 3.33 |
| Bracket Weldment | 3.33 |
| Bolt, 1/4" - 20 x 2 1/4" | 3.33 |
| Bolt, 5/8" - 18 x 1 1/2" | 3.33 |
| Flat Washer, 5/8" | 3.33 |
| Lock Nut, 1/4" | 3.33 |
| Lock Washer, 5/8" | 3.33 |
| Washer, 1 1/4" | 3.33 |

| | |
|-------------------------------|-----------|
| Plug, Drain, Water Tank | 3.3, 3.23 |
|-------------------------------|-----------|

| | |
|----------------------------|-----|
| Pre-Cleaner Assembly | 3.3 |
|----------------------------|-----|

| | |
|-------------------------------|------------|
| Pump, Main Transmission | 3.24, 3.25 |
|-------------------------------|------------|

| | |
|---------------------------|------------|
| Pump, Tandem, Eaton | 3.24, 3.25 |
|---------------------------|------------|

Q

R

| | |
|--|------|
| Rod, Bellcrank Control, 4 5/8" L | 3.27 |
|--|------|

| | |
|--------------------------------|------|
| Rod, Brake Lever, Plated | 3.26 |
|--------------------------------|------|

S

| | |
|------------|-----|
| Seat | 3.2 |
|------------|-----|

| | |
|---------------------|------|
| Set, Arm Rest | 3.21 |
|---------------------|------|

Spray Bar:

| | |
|---|------------|
| 6 Foot | 3.39 |
| 8 Foot | 3.39 |
| Barbed Tee Water Fitting, 3/8" | 3.39 |
| Bolt, 3/8" - 16 x 1 1/4", Zinc Plated | 3.39 |
| Brass Cap | 3.30, 3.39 |
| Brass Seal | 3.30, 3.39 |
| Brass Water Fitting, 90° | 3.39 |
| Brass Water Fitting, Tee | 3.39 |
| Check Valve Strainer | 3.30, 3.39 |
| Clamp w/Screw | 3.30, 3.39 |
| Flat Washer, 3/8" | 3.39 |
| Lock Washer, 3/8" | 3.39 |
| Nut | 3.30 |

| | |
|--|------|
| Spray Hose, 3/8" (6 - 10 1/2", 2 - 4 1/2") | 3.39 |
|--|------|

| | |
|------------------------|------|
| Spray Hose Clamp | 3.39 |
|------------------------|------|

| | |
|-----------------------|------|
| Spray Kit Items | 3.30 |
|-----------------------|------|

| | |
|---------------------------------------|-----|
| Spring, Brake Extension, 3/4 OD | 3.3 |
|---------------------------------------|-----|

| | |
|-------------------------------------|------|
| Spring, Forward/Reverse Pedal | 3.24 |
|-------------------------------------|------|

| | |
|-------------------------------------|------|
| Spring, Large, Frame to Broom | 3.15 |
|-------------------------------------|------|

| | |
|-----------------------------------|-----|
| Strainer, Drain, Water Tank | 3.3 |
|-----------------------------------|-----|

| | |
|--|-----|
| Strap, Front Holding, Water Tank | 3.3 |
|--|-----|

| | |
|---------------------------------------|-----|
| Strap, Rear Holding, Water Tank | 3.3 |
|---------------------------------------|-----|

| | |
|------------------------|------------|
| Switch, Ignition | 3.17, 3.18 |
|------------------------|------------|

T

| | |
|-----------------|------|
| "T" Block | 3.26 |
|-----------------|------|

| | |
|-------------------|-----|
| Tank, Water | 3.2 |
|-------------------|-----|

| | |
|----------------------------|------------|
| Transmission: | 3.48, 3.49 |
|----------------------------|------------|

| | |
|--|---|
| Adapter Assembly | Back Up Washer |
| Backplate Assembly | Bearing |
| Bearing Race | Bearing, Thrust |
| Camplate | Cap Screw |
| Check Valve Assembly | Coupler |
| Cover Plate | Drive Shaft |
| Gerotor and Coupler | Housing Assembly |
| Housing, Gasket | Inner Race |
| Key | O-Ring 3 ³ / ₃₂ " x 7/8" ID, Back Plate |
| O-Ring in Back | O-Ring, 1/16" x 3/8" |
| O-Ring, 1/16" x 3 1/4" | O-Ring, 3/32" x 15/16", Outer Pintle |
| O-Ring, 3 ³ / ₃₂ " x 4 1/64" | O-Ring, 3 ³ / ₃₂ " x 7/8" |
| O-Ring, Molded | O-Ring, Outer Pintle |
| O-Ring, 1/16" x 7/16" | Pin |
| Plate, Valve | Plug Assembly |
| Poppet Filter Relief | Relief Valve Assembly |

Transmission (Continued):

| |
|------------------------------|
| Retaining Ring |
| Rotating Rebuild Kit, Cessna |
| Seal Cover |
| Seal, Pintle |
| Shaft Seal |
| Spreader |
| Spring Retainer |
| Steel Ball |
| Washer |

| |
|------------------------------------|
| Rotating Kit Assembly |
| Screws |
| Seal Repair Kit |
| Separator Plug |
| Sleeve Cover |
| Spring |
| Spring, Transmission, Relief Valve |
| Trunnion Cover |

U

| | |
|---|------|
| U-Bolt, w/Nuts "U", 1/2NF x 31W x 6"L | 3.15 |
|---|------|

V

| | |
|---|------|
| Valve, Control, Variable, Broom RDRS-105-16 | 3.20 |
|---|------|

| | |
|------------------------------|------------|
| Valve, Forward/Reverse | 3.10, 3.26 |
|------------------------------|------------|

| | |
|-------------------------|------------|
| Valve, Lift/Angle | 3.19, 3.20 |
|-------------------------|------------|

| | |
|----------------------|--------------------------|
| Valve, Tow Bar | 3.2, 3.5, 3.7, 3.8, 3.10 |
|----------------------|--------------------------|

W

| | |
|--------------------------|-----|
| Wafer, Poly, Brush | 3.1 |
|--------------------------|-----|

| | |
|--------------------------|-----|
| Wafer, Wire, Brush | 3.1 |
|--------------------------|-----|

| | |
|----------------------------|------|
| Water Hose Connector | 3.29 |
|----------------------------|------|

| | |
|------------------|------|
| Water Pump | 3.29 |
|------------------|------|

| | |
|-------------------------|------|
| Water Pump Filter | 3.29 |
|-------------------------|------|

| | |
|---------------------------|------------|
| Water Spray Orifice | 3.30, 3.39 |
|---------------------------|------------|

| | |
|-------------------------------------|------|
| Water System, 3/8 Crimp Clamp | 3.29 |
|-------------------------------------|------|

| | |
|---|------|
| Water System, 3/8 Mnpt x 1/2 Mnpt Step Nipple | 3.29 |
|---|------|

| | |
|---|------|
| Water System, 3/8 Mnpt x 90° x 3/8 Barb | 3.29 |
|---|------|

| | |
|-------------------------------------|------|
| Water System, 3/8 Plastic "T" | 3.29 |
|-------------------------------------|------|

| | |
|---|------|
| Water System, 1/2 Mnpt x 3x8 Barb | 3.29 |
|---|------|

| | |
|------------------------------|------|
| Water System, 90° Body | 3.29 |
|------------------------------|------|

| | |
|------------------------------|------|
| Water System, "T" Body | 3.29 |
|------------------------------|------|

| | |
|------------------|------|
| Water Tank | 3.29 |
|------------------|------|

| | |
|----------------------|------|
| Water Tank Cap | 3.29 |
|----------------------|------|

| | |
|-----------------------------|------|
| Water Tank Drain Plug | 3.29 |
|-----------------------------|------|

| | |
|-----------------------|-----------|
| Wheel, Steering | 3.2, 3.17 |
|-----------------------|-----------|

X

Y

| | |
|---------------------------------------|------|
| Yoke, Lever, Brake, 1/2" - 20NF | 3.16 |
|---------------------------------------|------|

Z

SAMPLE Limited New Product Warranty

WE WARRANT TO THE ORIGINAL CONSUMER/ PURCHASER THAT EACH NEW PRODUCT SOLD BY US WILL BE FREE FROM MANUFACTURING DEFECTS IN NORMAL SERVICE USE FOR A PERIOD OF ONE (1) YEAR FROM DATE OF PURCHASE.

Our obligation under this warranty is expressly limited, solely at our option, to the replacement or repair at the premises of Terramite Corporation, 600 Goff Mountain Road, Charleston, West Virginia 25356, or at a service facility designated by us, of such part or parts as inspection shall disclose to have been defective. This warranty does not apply to defects caused by casualty or unreasonable use (including faulty repairs by others and failure to provide reasonable and necessary maintenance) nor to ordinary wear and tear, while in the possession of the consumer/purchaser.

This warranty is for replacement or repair of defective parts only, and does not provide for replacement of complete products due to a defective part or parts nor does it cover any charges of whatever kind in connection with the replacement of any such defective parts.

We shall not be responsible for special, indirect, incidental or consequential damages of any kind including, but not limited to, labor costs or transportation charges in

connection with the replacement or repair of defective parts.

Components such as engines, pumps and batteries which are supplied by other manufacturers, are warranted by the manufacturer's nearest "Factory Service Center" for repair or replacement of those items. However, when necessary, the manufacturer will act as your agent to secure adjustment.

To obtain warranty service, purchaser must bring the product to an authorized Terramite Service facility. For the facility nearest you, contact Terramite Corporation, P.O. Box 7146, Charleston, WV 25356 or telephone (304) 776-4231.

This warranty gives you specific rights and you may have other rights which vary from state to state. This warranty is in lieu of any other warranty, whether written, verbal, expressed or implied and may not be modified or changed by Terramite Distributors or Dealers. This warranty shall be null and void unless the section below has been filled in and the manufacturer's copy of this document is returned to Terramite Corporation, P.O. Box 7146, Charleston, WV 25356 within ten (10) days of the date of purchase by the original owner.

MODEL# _____ SERIAL# _____ ENGINE# _____
 PURCHASED FROM _____ CERTIFICATE OF ORIGIN# _____
 NAME OF PURCHASER _____
 ADDRESS _____
 PHONE (____) _____ CERTIFICATE OF ORIGIN# _____
 TYPE OF BUSINESS _____
 IS THIS YOUR FIRST TERRAMITE? _____
 WHAT KIND OF SIMILAR EQUIPMENT DO YOU OWN? _____

 OPTIONS _____

 DATE OF PURCHASE _____ SIGNATURE _____

(ORIGINAL PURCHASER)

**Fill in the information requested above.
 This will be useful anytime you need to order parts.**

**This is only a SAMPLE of the Limited New Product Warranty
 provided with each new machine to the original owner.**