

GENERAL PURPOSE ENGINE

GX160K1
(GC02-200/610/910)
GX160K1
(PROPANE ENGINE)
(GDA-200)

PARTS CATALOGUE

10



GX160K1

FOREWORD INDEX

1

ENGINE GROUP

2

PART NUMBER INDEX

3

PART NAME INDEX

4

Instruction for use of parts catalogue

- **This parts catalogue was prepared based on the latest information available as of September 10, 2004.**
- See the parts catalogue news for any revision that is made after September 10, 2004.
- **Always specify the part number when ordering a part.**
- Check the model, type, serial numbers, color, maker, and the size as needed before ordering a part.
- Note that the illustrations (part drawings) can differ from the actual parts in shape. They are given just to help you to refer to the parts.
- **When modifications or additions to this parts catalogue are made, a revised edition will be issued at an appropriate time, with successively progressing revision numbers on the cover. We recommend obtaining such revisions in order to keep your parts catalogue up-to-date at all times. To check whether a parts catalogue revision has been issued, please contact your Honda distributor.**

Initial version issue date January 01, 1991
Honda Motor Co., Ltd.

CONTENTS

	Page	Address No.	
● How to refer to the part information	2	B 2	1
● Part catalogue structure	3	B 3	
● When the parts were revised	4	B 4	
● Abbreviations used in the parts catalogue.....	4	B 4	
● How to check the part block and serial numbers.....	5	B 5	
● Models, parts catalogue codes and applicable serial numbers	6	B 6	
● Features of each type.....	17	C 1	
● Fuel hose, general purpose hoses and vinyl hose.....	42	D10	
● FLAT RATE SERVICE TIME.....	43	D11	
● Illustrated index	48	D16	
● ENGINE GROUP.....	56	F 1	2
● PART NO. INDEX.....	317	2-J 1	3
● PART NAME INDEX.....	325	2-K 1	4

How to refer to the part information

1

A Reference with "Illustrated index"

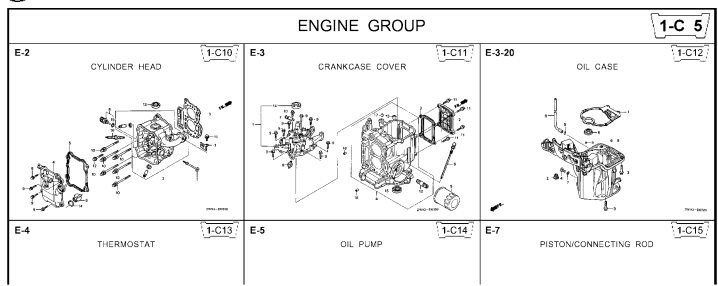

B Reference with "Part number index"

PART NO. INDEX

Part Number	Address	Page	Ref.	Part Number	Address	Page
06000				15212-ZW9-000	1-C14	3C
06316-ZW9-000	1-G9	88	1	15220-ZW9-003	1-C14	3C
11000				15332-ZW9-000	1-E8	55
11300-ZW9-405	1-C11	27	1	15332-ZW9-A30	1-E11	5E
11300-ZW9-406	1-C11	27	1	15400-PFB-004	1-C11	27
11340-ZW9-000	1-C11	27	2	15422-ZW9-000	1-C14	3C
11342-ZW9-000	1-C11	27	3	15473-881-000	1-C14	3C
11381-ZW9-003	1-C12	28	1	15474-ZW9-000	1-C14	3C
				15611-921-000	1-C10	2E
				15655-ZW9-000	1-C11	27
				16000		
12000				16010-ZV4-005	1-D4	3E
12000-ZW9-405ZA	1-C11	27	4	16011-ZV4-005	1-D4	3E
12155-ZV4-A00	1-C13	29	1	16013-ZW9-003	1-D4	3E
12166-ZW9-000	1-C10	26	1	16016-ZW9-003	1-D4	3E
12209-GB4-681	1-C16	32	1	16016-ZW9-721	1-D4	3E
12210-ZW9-405ZA	1-C10	26	2	16023-ZW9-003	1-D4	3E
12216-ZE2-300	1-E8	55	1	16024-ZV4-650	1-D4	3E
	1-E11	58	1	16028-ZV4-650	1-D4	3E

C Reference with "Part name index"

PART NAME INDEX

Part name	Address	Page	Ref.
[A]			
ABSORBER, FUEL	1-E15	62	5
ARMATURE COMP.	1-D11	43	7
ARM COMP., LINK JOINT	1-G6	85	18
ARM COMP., SHIFT LINK	1-G6	85	14
ARM COMP., TILT	1-F15	79	20
ARM, FUEL PUMP ROCKER	1-C16	32	4
ARM, REVERSE LOCK	1-F15	79	18
ARM, SHIFT LINK	1-F11	74	7
ARM, STOPPER	1-D1	33	12
ARM, THROTTLE REMOTE	1-F11	74	6
ARM, VALVE ROCKER	1-C16	32	3
[B]			
BAG, TOOL, 160MM	1-G5	84	10
BAND	1-G6	86	37
BAND B1, WIRE	1-F6	69	1
BAND, CORD	1-F3	67	18
BAND, TUBE CLIP, 11MM	1-E15	63	20
BAND, TUBE CLIP, 12.5MM	1-E15	63	19

Address No. 1-C10

E-2 CYLINDER HEAD

Block No.

Ref No.

Ref. No.	Part No.	Description	Reqd. QTY						Serial No.	Parts catalogue code
			9901	9901	1001	1001	1001	1001		
1	12166-ZW9-000	STOPPER, ENGINE SIDE	2	2	2	2	2			
2	12210-ZW9-000ZA	HEAD COMP., CYLINDER	1	1	1	1	1			
3	12251-ZW9-003	GASKET, CYLINDER HEAD	1	1	1	1	1			
4	12310-ZW9-000	COVER COMP., HEAD	1	1	1	1	1			
5	12312-ZW9-000	PACKINGS, HEAD COVER	1	1	1	1	1			
6	15611-921-000	CAP, OIL (NO GAUGE)	1	1	1	1	1			
7	16617-ZW9-000	HOLDER, CABLE	1	1	1	1	1	SC,SG		
	16617-ZW9-010		1	1	1	1	1	1001800	LHC,LHD	
			1	1	1	1	1	1001801	LHC,LHD	
8	35673-ZW5-003	SENSOR ASSY., WATER	1	1	1	1	1			
9	90003-ZW9-000	BOLT, FLANGE, 6X22	4	4	4	4	4			
10	90007-ZW9-003	BOLT, FLANGE, 8X83	6	6	6	6	6			
11	90011-ZW9-000	BOLT, FLANGE, 6X14(CT200)	1	1	1	1	1			
12	90020-ZW9-000	BOLT, FLANGE, 8X40	2	2	2	2	2			
13	91002-K19-003	OIL SEAL, 20X32X6	1	1	1	1	1			
14	91301-805-000	O-RING, 26X2.7	1	1	1	1	1			
15	91307-PK2-005	O-RING, 9.5X1.5(HONDA KIKAKI)	1	1	1	1	1			
16	98059-55916	PLUG, SPARK (CR5EH-9)	2	2	2	2	2			
	98059-55926	PLUG, SPARK (U16FER9)	2	2	2	2	2			

Service item F.R.T.

- O-RING, 26X2.7 0.1
- PLUG, SPARK 0.2
- O-RING, 9.5X1.5 0.2
- SENSOR ASSY., WATER TEMPERATURE 0.3
- COVER COMP., HEAD 0.3
- PACKING, HEAD COVER 1.8
- GASKET, CYLINDER HEAD 2.4
- OIL SEAL, 20X32X6 2.4
- HEAD COMP., CYLINDER 3.1

ZW83-ED200

Page No. 2000.09.20 E

Part catalogue structure

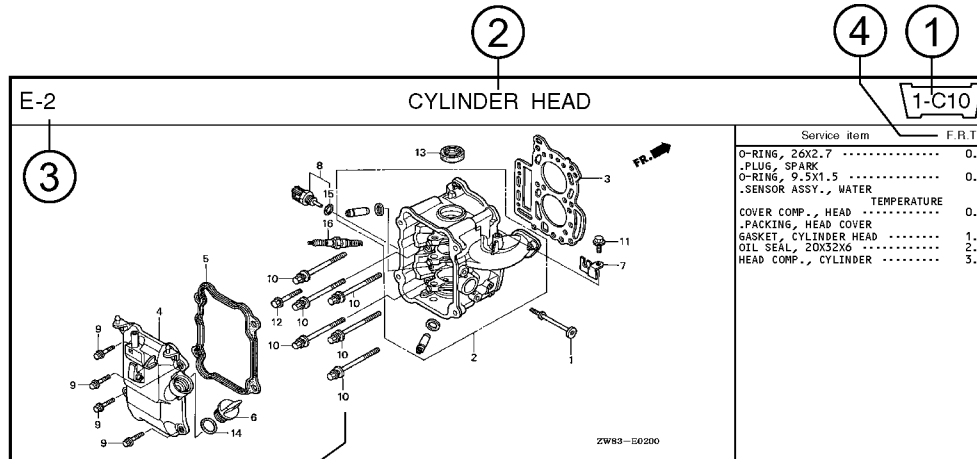

Ref. No.	Part No.	Description	Reqd. QTY						Serial No.	Parts catalogue code
			BF 9/9D1	BFP 9/9D1	BF 10D1	BFP 10D1	BF 10E1	BFP 10E1		
1	12166-ZW9-000	STOPPER, ENGINE SIDE	2	2	2	2	2	2		
2	12210-ZW9-000ZA	HEAD COMP., CYLINDER *NHS* DARK GRAY	1	1	1	1	1	1		
3	12251-ZW9-003	GASKET, CYLINDER HEAD	1	1	1	1	1	1		
4	12310-ZW9-000	COVER COMP., HEAD	1	1	1	1	1	1		
5	12312-ZW9-000	PACKING, HEAD COVER	1	1	1	1	1	1		
6	15611-921-000	CAP, OIL (NO GAUGE)	1	1	1	1	1	1		
7	16617-ZW9-000	HOLDER, CABLE	1	1	1	1	1	1	SC,SG	
	16617-ZW9-010		1	1	1	1	1	1	1001800 LHC,LHD	

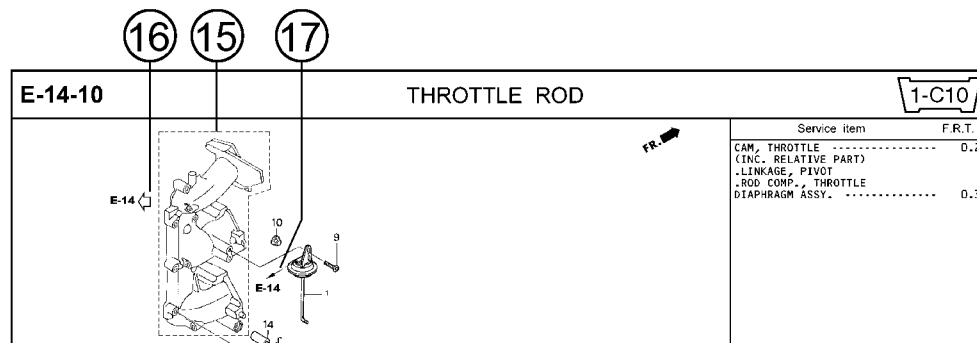

① Address number

- Address No. is provided (in place of the page No.) to help you refer to the part with the part No. or part name.

② Block title ③ Block number

④ Service item/Flat rate time

⑤ Reference number

- Title number marked with the parenthesis or parentheses indicates that it continues from the previous page.

⑥ Part number ⑦ Honda color code

⑧ Description

⑨ Assemblies

- Sections framed with broken lines in the exploded view drawings are available as complete assemblies. (Their individual parts can also be obtained.)

⑩ Color description

⑪ Note

- Notes are shown with the parentheses in the part name column.

⑫ Required quantity

- Required QTY shown in the parenthesis or parentheses indicates the optional part.
- Required QTY marked with "N" Indicates the optional part that should be selected as needed.
- Required QTY indicates the number of the part used in the block.

⑬ Serial number

⑭ Type

- When the type column is blank, it indicates that the part is applicable to all types.
- As the type of the actual unit may differ from the "parts catalogue, type" please refer to "Models, types and applicable serial numbers" for confirmation.

⑮

- Parts enclosed within a dotted line are covered in a different block.

⑯

- A hollow arrow indicates the block No. for the parts enclosed within a dotted line .

⑰

- A solid arrow indicates the block No. the part in question is connected to.

When the parts were revised

Abbreviations used in the parts catalogue

1



Be sure to check the serial number!!



Ref. No.	Part No.	Description	Reqd. QTY						Serial No.
			BF 99D1	BFP 9.9D1	BF 10D1	BFP 10D1	BF 10B1	BFP 10B1	
1	12166-ZW9-000	STOPPER, ENGINE SIDE	2	2	2	2	2	2	
2	12210-ZW9-000ZA	HEAD COMP., CYLINDER *NH8* DARK GRAY	1	1	1	1	1	1	
3	12251-ZW9-003	GASKET, CYLINDER HEAD	1	1	1	1	1	1	
4	12310-ZW9-000	COVER COMP., HEAD	1	1	1	1	1	1	
5	12312-ZW9-000	PACKING, HEAD COVER	1	1	1	1	1	1	
6	15611-921-000	CAP, OIL (NO GAUGE)	1	1	1	1	1	1	
7	16617-ZW9-000	HOLDER, CABLE (###)	1	1	1	1	1	1	
	16617-ZW9-010	1	1	1	1	1	1	



The number has been used from the initial model without revision. When shown at the left side, it is applicable to the models of No.1001801 and the subsequent numbers. When shown at the right side, it is applicable to the models up to No.1001800.

• The parts listed with "###" at the end of the parts name have limited supply period (parts not for sale).

• The following abbreviations are used in the parts name column.

- | | |
|--|-----------------------------|
| A Ampere | FR.Front |
| A.C. Alternating current | IN.Inlet |
| ASSY. Assembly | L (100L) .Link (100 Links) |
| AT. Automatic transmission | L.Left |
| C.D.I. Capacitive discharge ignition | MMMillimeter |
| COMP. ... Complete | MT.Manual Transmission |
| D.C. Direct current | P.T.O.Power take off |
| EX. Exhaust | R.Right |
| G.F.C.I ... Ground fault circuit interruptor | RR.Rear |
| HEX. Hexagonal | STD.Standard |
| H.S.T. Hydrostatic transmission | T (22T) ...Tooth (22 Teeth) |
| | V Volt |
| | WWatt |

How to check the part block and serial numbers

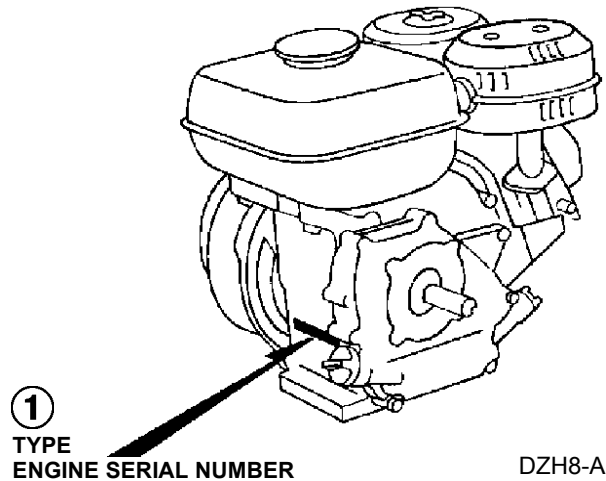
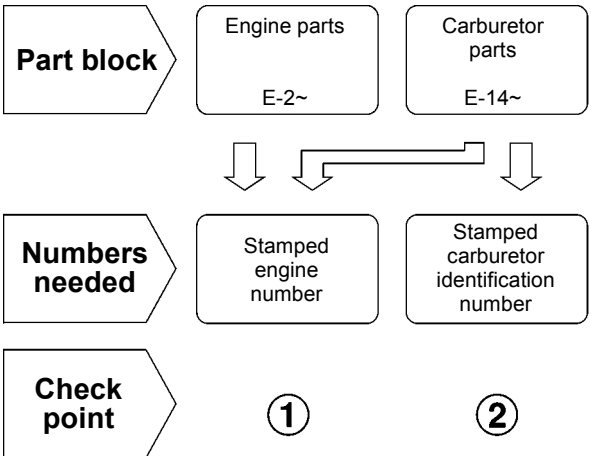

②-B
CARBURETOR
IDENTIFICATION NUMBER
GX160K1 (1) (2) (3)

②-A
CARBURETOR
IDENTIFICATION NUMBER
GX160K1 (1) (2) (3)

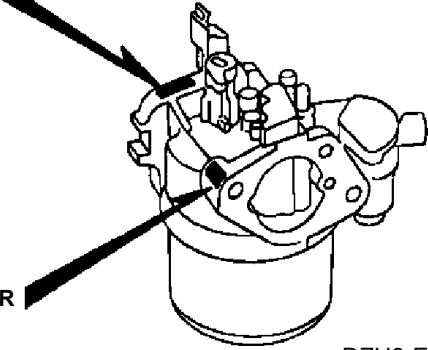

②
CARBURETOR
IDENTIFICATION NUMBER
GX160K1 (4)

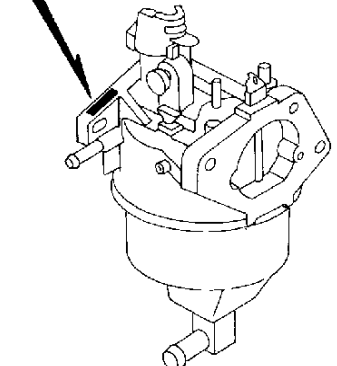

Models, parts catalogue codes and applicable serial numbers

• Models, parts catalogue codes and applicable serial Nos. given in this parts catalogue can be identified as follows.

Model	Type	Parts catalogue type	Applicable engine serial No.	Applicable carburetor identification No.	Model	Type	Parts catalogue type	Applicable engine serial No.	Applicable carburetor identification No.		
GX160K1 (1)	AR	AR	GC02- 2000001~8669999	BE67B B	GX160K1 (1)	HXE2	HXE2	GC02- 6100001~8669999	BE65B B		
	ARC6	ARC6		BE67C A		HXE8	HXE8	GC02- 2000001~8669999	BE06J C BE65B B		
	BL	BL	GC02- 6100001~8669999	BE65M A		HXQ	HXQ	GC02- 2000001~5984124	BE65A A / B		
	DS	DS	GC02- 2000001~6463462	BE06J A / B / C		HXU	HXU	GC02- 2000001~8669999	BE06J C BE65B B		
	DSP	DSP		BE65C B		HX2	HX2		BE65B A / B		
	EMA	EMA	GC02- 2000001~4223072	BE51A A / B BE67A B		HX26	HX26		GC02- 6100001~8669999	BE06J B / C BE65B B	
	EMA2	EMA2	GC02- 2000001~8669999	BE67A A / B		HX4	HX4	GC02- 6100001~8669999		BE06J B / C BE67B B BE67C A BE06J A / B / C BE65B B	
	EN	EN	GC02- 2000001~5984124	BE06J A / B / C		KR	KR	GC02- 2000001~8669999	BE06J A / B / C BE65B B		
	ET	ET				KTA	KTA			LAX	LAX
	ETX	ETX				GC02- 2000001~8669999	BE65B A / B	LAX2	LAX2	GC02- 2000001~8669999	BE06H A / B / C BE66E B
	HG1	HG1						LD	LD	GC02- 2000001~5519983	BE06H B / C
	HG12	HG12	GC02- 2000001~8669999	BE65B A / B		LDB1	LDB1	GC02- 2000001~5547391	BE06H C BE66E B		
	HH	HH		BE06J A / B / C BE65B B		LDB3	LDB3	GC02- 2000001~6463462		BE06H B / C BE66E B	
	HHQ4	HHQ4		BE06J B / C BE65B B		LDM	LDM	GC02- 2000001~8669999	BE06H C BE66E B		
	HH26	HH26		BE65B A / B		LD4	LD4	GC02- 2000001~8669999	BE06H B / C BE66E B		
HX	HX	BE06J A / B / C BE65B B		LH	LH	GC02- 2000001~8669999	BE06J A / B / C BE65B B				
HXE	HXE	BE06J B / C BE65B B									

Model	Type	Parts catalogue type	Applicable engine serial No.	Applicable carburetor identification No.
GX160K1 (1)	LHB3	LHB3	GC02- 2000001~8669999	BE06J B / C BE65B B
	LHQ4	LHQ4		
	LHW	LHW		BE06J C
	LJ	LJ		BE06J A / B / C BE65C B
	LJC7	LJC7		BE06J C BE65C B
	LJD	LJD	GC02- 2000001~6463462	BE06J B / C
	LJG	LJG	GC02- 2000001~8669999	BE06J B / C BE65C B
	LJS	LJS		BE06J A / B / C
	LMT	LMT		BE06J C BE65B B
	LSJ	LSJ		BE06H C BE66E B
	LSJ4	LSJ4		BE06J B / C BE65C B
	LSS	LSS	GC02- 2000001~6463462	BE06J B / C
	LSS1	LSS1	GC02- 2000001~8669999	BE11C B
	LSS4	LSS4	GC02- 2000001~5984124	BE06H A / B / C
	LTA	LTA	GC02- 2000001~6463462	BE06J A / B / C
	LTK	LTK	GC02- 2000001~8669999	BE65M A
	LVL	LVL		

Model	Type	Parts catalogue type	Applicable engine serial No.	Applicable carburetor identification No.
GX160K1 (1)	LW2	LW2	GC02- 2000001~8669999	BE06H A / B / C
	LX	LX		BE06J A / B / C BE65B B
	LXU	LXU		BE06J C BE65B B
	LX2	LX2		BE65B A / B
	LX26	LX26		
	LX4	LX4		BE06J B / C BE65B B
	NJ	NJ	BE06J B / C BE65C B	
	NJC1	NJC1	GC02- 6100001~8669999	BE51B B
	NJG	NJG	GC02- 2000001~8669999	BE06J B / C BE65C B
	NSJ	NSJ		BE06J C BE65C B
	NW	NW	GC02- 2000001~5200121	BE06J C BE65B B
	PH	PH	GC02- 2000001~6463462	BE06J A / B / C BE65B B
	PHM	PHM	GC02- 2000001~8669999	BE06J C BE65B B
	PHU	PHU		BE06U A / B BE66D B
	PM	PM	GC02- 2000001~5984124	BE06H A / B / C
	PM2	PM2	GC02- 2000001~8669999	BE06H A / B / C BE66E B
	PX	PX		BE06J A / B / C BE65B B

Model	Type	Parts catalogue type	Applicable engine serial No.	Applicable carburetor identification No.
GX160K1 (1)	PXU	PXU	GC02- 2000001~8669999	BE06J C BE65B B
	PX2	PX2	GC02- 2000001~6463462	BE65B A / B
	QA	QA	GC02- 2000001~5454007	BE06J A / B / C BE65C B
	QAB1	QAB1	GC02- 2000001~8669999	BE06J B / C BE65C B
	QAB3	QAB3		
	QAX	QAX	GC02- 2000001~5984124	BE06J B / C
	QAX2	QAX2	GC02- 2000001~8669999	BE65B A / B
	QA2	QA2		BE65C A / B
	QA26	QA26		
	QBC2	QBC2	GC02- 6100001~8669999	BE65B B
	QBT2	QBT2	GC02- 2000001~6463462	BE65B A / B
	QBT6	QBT6	GC02- 2000001~8669999	
	QBU2	QBU2	GC02- 2000001~5984124	
	QCB2	QCB2	GC02- 2000001~8669999	BE65B B
	QCL	QCL	GC02- 6100001~8669999	
	QD	QD	GC02- 2000001~8669999	BE06H A / B / C BE66E B
	QE	QE		BE06H A / B / C BE66D B

Model	Type	Parts catalogue type	Applicable engine serial No.	Applicable carburetor identification No.
GX160K1 (1)	QFE4	QFE4	GC02- 2000001~8669999	BE06H C BE66D B
	QGR2	QGR2		BE65B A / B
	QGR9	QGR9		BE65B B
	QH	QH		BE06J A / B / C BE65B B
	QHE	QHE		
	QHP1	QHP1		
	QHQ4	QHQ4		
	QH26	QH26		
	QI2	QI2		GC02- 6100001~8669999
	QKA4	QKA4	GC02- 2000001~8669999	BE06J B / C
	QM	QM		BE06H A / B / C
	QMC6	QMC6		BE06H B / C BE66E B
	QMC8	QMC8		BE06J B / C BE65B B
	QMD6	QMD6		BE06J B / C BE06J C BE65B B
	QME4	QME4		
	QMH	QMH		
	QMX2	QMX2		

Model	Type	Parts catalogue type	Applicable engine serial No.	Applicable carburetor identification No.
GX160K1 (1)	QMZ2	QMZ2	GC02- 2000001~8669999	BE65B A / B
	QNT	QNT		BE06J A / B / C BE65B B
	QNT2	QNT2	GC02- 2000001~5984124	BE65B A / B
	QNT4	QNT4	GC02- 2000001~8669999	BE11C B
	QNZ	QNZ		BE06H B / C
	QP	QP		BE06J B / C BE65B B
	QPU	QPU		BE65G A / B
	QSC2	QSC2		BE65G B
	QSC9	QSC9		BE65B B
	QS2	QS2	GC02- 6100001~8669999	BE65B B
	QT	QT	GC02- 2000001~8669999	BE06J A / B / C
	QVL	QVL	GC02- 6100001~8669999	BE65M A
	QWA4	QWA4	GC02- 2000001~8669999	BE65B B
	QWM2	QWM2		
	QWX2	QWX2		
	QWX3	QWX3		
QX	QX	BE06J A / B / C BE65B B		

Model	Type	Parts catalogue type	Applicable engine serial No.	Applicable carburetor identification No.
GX160K1 (1)	QXB	QXB	GC02- 2000001~5984124	BE06J A / B / C
	QXB1	QXB1	GC02- 2000001~6463462	BE06J B / C BE65B B
	QXC	QXC	GC02- 2000001~8669999	BE11C A / B BE65G B
	QXC6	QXC6		BE65G A / B
	QXC9	QXC9		BE06J A / B / C BE65B B
	QXE	QXE		BE65B A / B
	QXE2	QXE2		BE06J B / C BE65B B
	QXE4	QXE4		BE65B A / B
	QXE6	QXE6	BE06J C BE65B B	
	QXE8	QXE8	GC02- 2000001~5984124	BE06J A / B / C
	QXF	QXF	GC02- 2000001~8669999	BE65B A / B
	QXF2	QXF2		BE06J C
	QXM1	QXM1		BE65A A / B
	QXQ	QXQ	GC02- 2000001~5984124	BE06J A / B / C
	QXS	QXS		BE65B A / B
	QXS2	QXS2	GC02- 2000001~8669999	BE06J C BE65B B
	QXU	QXU		BE06J C BE65B B

Model	Type	Parts catalogue type	Applicable engine serial No.	Applicable carburetor identification No.
GX160K1 (1)	QXW	QXW	GC02- 2000001~8669999	BE06J A / B / C BE65B B
	QXW2	QXW2		BE65B A / B
	QX2	QX2		
	QX22	QX22	GC02- 6100001~8669999	BE65B B
	QX26	QX26	GC02- 2000001~8669999	BE65B A / B
	QX4	QX4		BE06J B / C BE65B B
	QX7	QX7	GC02- 6100001~8669999	BE65B B
	QZ	QZ	GC02- 2000001~5984124	BE06S A / B
	RAC	RAC		BE06J A / B / C
	RD	RD	GC02- 2000001~8669999	BE06H A / B / C BE66E B
	RD4	RD4		BE06H B / C BE66E B
	REX4	REX4	GC02- 2000001~6463462	BE06J C
	RFR	RFR	GC02- 2000001~5984124	BE06J A / B / C
	RFR2	RFR2	GC02- 2000001~8669999	BE65B A / B
	RH	RH		BE06J A / B / C BE65B B
	RHA	RHA	GC02- 2000001~5984124	BE06J A / B / C
RHA2	RHA2	GC02- 2000001~8669999	BE65B A / B	

Model	Type	Parts catalogue type	Applicable engine serial No.	Applicable carburetor identification No.
GX160K1 (1)	RHQ4	RHQ4	GC02- 2000001~8669999	BE06J B / C BE65B B
	RH2	RH2		BE65B A / B
	RH26	RH26		BE06J B / C
	RMB4	RMB4		BE06J A / B / C
	RMD	RMD		
	RMG2	RMG2	GC02- 6100001~8669999	BE65B A / B
	RNG	RNG	GC02- 2000001~5010641	BE06J B / C BE65C B
	RSK	RSK	GC02- 2000001~8669999	BE06J A / B / C BE65B B
	RSS1	RSS1		BE06J C BE65C B
	RTB2	RTB2		BE65B A / B
	RX	RX	GC02- 6100001~8669999	BE06J A / B / C BE65B B
	RXE	RXE		
	RXE2	RXE2	GC02- 6100001~8669999	BE65B B
	RXE4	RXE4	GC02- 2000001~8669999	BE06J B / C BE65B B
	RXU	RXU		BE06J C BE65B B
	RX4	RX4		BE06J B / C BE65B B
	SAC	SAC	GC02- 2000001~5984124	BE06J A / B / C

Model	Type	Parts catalogue type	Applicable engine serial No.	Applicable carburetor identification No.	Model	Type	Parts catalogue type	Applicable engine serial No.	Applicable carburetor identification No.	
GX160K1 (1)	SAD2	SAD2	GC02-2000001~5984124	BE65B A / B	GX160K1 (1)	SHRY	SHRY	GC02-2000001~8669999	BE06J C BE65C B	
	SCJ	SCJ	GC02-2000001~8669999	BE06J A / B / C BE65C B		SHR4	SHR4		GC02-2000001~6463462	BE06J A / B / C BE65C B
	SD	SD		BE06H A / B / C BE66E B		SJ	SJ			BE06J B / C BE65C B
	SDB1	SDB1		BE06H B / C BE66E B		SJC	SJC	BE06J C BE65C B		
	SDB3	SDB3		GC02-2000001~5100005		BE06J C	SJC1	SJC1	BE06J B / C BE65C B	
	SDN	SDN	GC02-2000001~8669999	BE06H A / B / C BE66E B		SJC5	SJC5	GC02-2000001~8669999	BE06J C BE65C B	
	SDS	SDS	GC02-2000001~8669999	BE06J B / C BE65C B		SJG	SJG	GC02-2000001~8669999	BE06J B / C BE65C B	
	SDS2	SDS2	GC02-2000001~6463462	BE06J B / C		SKM	SKM		BE07C A / B	
	SDS3	SDS3	GC02-2000001~8669999	BE06J B / C		SMB4	SMB4	GC02-2000001~5984124	BE06J B / C	
	SD16	SD16	GC02-6100001~8669999	BE06H B / C BE66E B		SMC7	SMC7	GC02-2000001~8669999	BE06J B / C BE65B B	
	SD4	SD4	GC02-2000001~8669999	BE06H A / B / C BE66D B		SMC9	SMC9		BE06J A / B / C	
	SE	SE	GC02-2000001~8669999	BE06H A / B / C BE66E B		SMJ	SMJ		BE06J A / B / C BE65B B	
	SEE	SEE	GC02-2000001~6463462	BE06H A / B / C BE66E B		SMJ1	SMJ1		BE65B A / B	
	SG24	SG24	GC02-2000001~8669999	BE65B A / B		SMW2	SMW2		GC02-6100001~8669999	BE65B B
	SH	SH		BE06J A / B / C BE65B B		SMX4	SMX4	GC02-2000001~8669999	BE06J C	
	SHM	SHM		BE06J C BE65B B		SM11	SM11	GC02-2000001~8669999	BE65B B	
SHQ4	SHQ4	BE06J B / C BE65B B		SM12	SM12					

Model	Type	Parts catalogue type	Applicable engine serial No.	Applicable carburetor identification No.	Model	Type	Parts catalogue type	Applicable engine serial No.	Applicable carburetor identification No.
GX160K1 (1)	SM14	SM14	GC02- 2000001~8669999	BE06J C BE65B B	GX160K1 (1)	SXB	SXB	GC02- 2000001~4927944	BE06J A / B / C
	SNX	SNX		BE06J B / C		SXE	SXE	GC02- 2000001~8669999	BE06J A / B / C BE65B B
	SNX1	SNX1		BE06J C		SXE4	SXE4		BE06J B / C BE65B B
	SSK1	SSK1		BE06J B / C BE65B B		SXS4	SXS4		BE65B B
	SSK2	SSK2	GC02- 2000001~5984124	SXU		SXU	BE06J C BE65B B		
	SSX2	SSX2	GC02- 2000001~8669999	BE65B A / B		SX4	SX4		BE06J B / C BE65B B
	ST	ST		BE06J A BE06R A / B		SX7	SX7	GC02- 6100001~8669999	BE65B B
	STA	STA	GC02- 2000001~5984124	BE06J A / B / C		S1CY	S1CY	GC02- 2000001~8669999	BE06J C BE65B B
	STM	STM	GC02- 2000001~8669999	BE06R A / B		TCS2	TCS2	GC02- 2000001~8669999	BE65B B
	STP	STP	GC02- 2000001~6463462	BE06J A / B / C BE65B B		TH	TH	GC02- 2000001~6463462	BE06J A / B / C BE65B B
	STQ	STQ		GC02- 2000001~8669999		BE06J B / C	THU	THU	GC02- 2000001~4007436
	SWG4	SWG4	GC02- 2000001~5984124			BE06H A / B / C	TX	TX	GC02- 2000001~8669999
	SWX	SWX	GC02- 6100001~8669999	BE65B B		TXC9	TXC9	BE65G A / B	
	SWX2	SWX2		GC02- 2000001~5984124		BE06H A / B / C	TXU	TXU	
	SWX4	SWX4	GC02- 2000001~8669999			BE06J A / B / C BE65B B	TX2	TX2	
	SW2	SW2		GC02- 2000001~5984124		BE06H A / B / C	TX26	TX26	
SX	SX	GC02- 2000001~8669999	BE06J A / B / C BE65B B	TX4	TX4				

Model	Type	Parts catalogue type	Applicable engine serial No.	Applicable carburetor identification No.	Model	Type	Parts catalogue type	Applicable engine serial No.	Applicable carburetor identification No.
GX160K1 (1)	UH	UH	GC02- 2000001~8669999	BE06J A / B / C BE65B B	GX160K1 (1)	VG24	VG24	GC02- 2000001~8669999	BE66D A / B
	UX	UX		BE06J C BE65B B		VH	VH	GC02- 2000001~4344207	BE06J A / B / C
	UXU	UXU		BE06J A / B / C		VHA7	VHA7	GC02- 6100001~8669999	BE65B B
	VA	VA	GC02- 2000001~5984124	BE06J A / B / C		VHH4	VHH4	GC02- 2000001~8669999	BE06J B / C BE65B B
	VA2	VA2	GC02- 2000001~8669999	BE65B A / B		VHQ4	VHQ4	GC02- 2000001~5984124	BE06J B / C
	VEBM	VEBM		BE06H A / B / C BE66D B		VMB3	VMB3	GC02- 2000001~8669999	BE06J B / C BE65B B
	VEB2	VEB2	GC02- 2000001~5984124	BE66D A / B		VMS4	VMS4		GC02- 6100001~8669999
	VED	VED	GC02- 2000001~8669999	BE06J A / B / C BE65C B		VMS7	VMS7	GC02- 2000001~8669999	
	VED1	VED1		BE51A A BE67A A / B		VMT	VMT		BE51A B BE67A B
	VED2	VED2		BE51A A / B BE67A B		VPM4	VPM4		GC02- 6100001~8669999
	VED3	VED3		BE06J B / C BE65C B		VPM5	VPM5		
	VED5	VED5		GC02- 6100001~8669999		BE65C B	VPM7	VPM7	
	VED6	VED6	GC02- 2000001~8669999	BE67A B		VPR4	VPR4	GC02- 2000001~8669999	GC02- 6100001~8669999
	VED7	VED7	GC02- 2000001~8669999			BE67A B	VPR7	VPR7	
	VEN2	VEN2	GC02- 6100001~8669999	BE67A B		VS	VS	GC02- 2000001~6463462	BE06J A / B / C BE65B B
VES	VES	GC02- 2000001~8669999			BE67A B	VSB1	VSB1	GC02- 2000001~8669999	BE51A B BE67A B
VGE4	VGE4	GC02- 2000001~8669999	BE06J B / C	VSD	VSD	BE06J A / B / C BE65B B			

1

Model	Type	Parts catalogue type	Applicable engine serial No.	Applicable carburetor identification No.	Model	Type	Parts catalogue type	Applicable engine serial No.	Applicable carburetor identification No.
GX160K1 (1)	VSD1	VSD1	GC02- 2000001~8669999	BE51A A / B BE67A B	GX160K1 (1)	VWA	VWA	GC02- 2000001~5984124	BE06J A / B / C
	VSD7	VSD7	GC02- 6100001~8669999	BE65B B		VWA2	VWA2	GC02- 2000001~8669999	BE65B A / B
	VSG	VSG		BE67A B		VW12	VW12		
	VSW	VSW	GC02- 2000001~8669999	BE51A A / B BE67A B		VX	VX		BE06J A / B / C BE65B B
	VSX	VSX		BE06J A / B / C		VXD	VXD	BE06J B / C BE65C B	
	VSX1	VSX1		BE06J A / B / C		VXD1	VXD1		
	VSX3	VSX3	GC02- 6100001~8669999	BE06J C BE65B B		VXE	VXE	GC02- 2000001~5984124	BE06J A / B / C
	VS1	VS1	GC02- 2000001~5984124	BE06J A / B / C		VXE4	VXE4	GC02- 2000001~8669999	BE06J B / C BE65B B
	VS17	VS17	GC02- 6100001~8669999	BE67A B		VXE6	VXE6	GC02- 2000001~6463462	BE65B B
	VS3	VS3	GC02- 2000001~8669999	BE51A A / B BE67A B		VXE7	VXE7	GC02- 6100001~8669999	
	VS4	VS4		BE06J C BE65B B		VXG	VXG	GC02- 2000001~4433284	BE06J B / C BE65B B
	VTD	VTD	GC02- 2000001~5293944	BE06J C BE65B B		VXM	VXM	GC02- 2000001~8669999	BE06J C BE65B B
	VTD1	VTD1		BE06J B / C		VXU	VXU		BE06J B / C
	VTE2	VTE2	GC02- 2000001~5984124	BE67A B		VXU1	VXU1	GC02- 2000001~5984124	BE06J C BE65B B
	VTU1	VTU1	GC02- 2000001~8669999	BE06J C		VXW	VXW		BE06J A / B / C
	VTX	VTX	GC02- 2000001~5294084	BE51A B		VXW1	VXW1	GC02- 2000001~8669999	BE06J B / C
VTX1	VTX1	GC02- 2000001~8669999	BE51A B BE67A B	VXW2	VXW2	BE65B A / B			

Model	Type	Parts catalogue type	Applicable engine serial No.	Applicable carburetor identification No.	Model	Type	Parts catalogue type	Applicable engine serial No.	Applicable carburetor identification No.	
GX160K1 (1)	VX2	VX2	GC02- 2000001~8669999	BE65B A / B	GX160K1 (2)	Q1	Q1	GC02- 2000001~8669999	BE06H A / B / C BE06J A / B / C BE11C A / B	
	VX26	VX26		BE06J B / C BE65B B		R1	R1			
	VX4	VX4		BE65B B		S1	S1			
	WDA6	WDA6	GC02- 6100001~8669999	BE65B B		T1	T1	GC02- 2000001~5984124		BE06H A / B BE06J A / B BE11C A
	WJP	WJP	GC02- 2000001~8669999	BE06J B / C BE65C B						
	WKD6	WKD6	GC02- 6100001~8669999	BE65C B		V1	V1			
	WKT2	WKT2	GC02- 2000001~8669999	BE65C A / B		W1	W1			
	WKT4	WKT4	BE65C B	QIH1				QIH1		GC02- 9100001~9999999
	WKT6	WKT6	GC02- 6100001~8669999	BE06H B / C BE66E B		UIH	UIH	BE06J B / C		
	WMB0	WMB0	GC02- 2000001~8669999	BE06H B / C BE66E B		VIH1	VIH1	BE65B B		
	WME2	WME2		BE65C A / B		GX160K1 (3) (Indonesia- KD)				
	WME4	WME4		BE06H C BE66E B						
	WMT	WMT		BE06H B / C BE66E B						
GX160K1 (2)	H1	H1	GC02- 2000001~5984124	BE06H A / B BE06J A / B BE11C A						
	L1	L1	GC02- 2000001~8669999	BE06H A / B BE06J A / B BE11C A / B						

Model	Type	Parts catalogue type	Applicable engine serial No.	Applicable carburetor identification No.
GX160K1 (3) (Indonesia-KD)	WIH1	WIH1	GC02- 9100001~9999999	BE06J C
GX160K1 (4) (Propane)	SXP1	SXP1	GDA- 2000001~2009999	BELOA A
	VSDP	VSDP	GDA- 2000001~2000028	
	VXP	VXP	GDA- 2000001~6463462	

* Of carburetor identification numbers, only the portions underlined in the example below are used for registration.

GX160K1 (1) (2) (3) BE 67B B KC †

GX160K1 (4) ^(A) ^(B)
BELOA A KC †

Features of each type

- See the following table for the features of each type.

Model		GX160K1														
		Standard equipment (1)														
Specifications	Type	AR	ARC6	BL	DS	DSP	EMA	EMA2	EN	ET	ETX	HG1	HG12	HH	HHQ4	
		Crankshaft	19mm Ø Straight													
20mm Ø Straight																
20mm Ø Spline (L=235.9)	●		●													
20mm Ø Spline (L=248.9)					●	●										
21mm Ø Spline												●	●	●	●	
24mm Ø Spline																
M16 Stepped thread																
M18 Stepped thread																
1/2" Stepped thread																
3/4" Thread																
5/8" Thread																
1/5" Tapered				●			●	●	●	●	●					
3/4" Tapered																
Coil	Lamp coil						●									
	Charge coil															
Control box																
Starter motor																
Oil alert							●	●			●	●	●			
Reduction		●	●	●	●	●					●	●	●	●	●	

Model		GX160K1														
		Standard equipment (1)														
Specifications		Type	HH26	HX	HXE	HXE2	HXE8	HXQ	HXU	HX2	HX26	HX4	KR	KTA	LAX	LAX2
Crankshaft	19mm Ø Straight															
	20mm Ø Straight															
	20mm Ø Spline (L=235.9)												●			
	20mm Ø Spline (L=248.9)														●	●
	21mm Ø Spline	●	●	●	●	●	●	●	●	●	●	●				
	24mm Ø Spline													●		
	M16 Stepped thread															
	M18 Stepped thread															
	1/2" Stepped thread															
	3/4" Thread															
	5/8" Thread															
	1/5" Tapered															
	3/4" Tapered															
Coil	Lamp coil															
	Charge coil			●	●	●									●	●
Control box				●	●	●										
Starter motor				●	●	●										
Oil alert			●	●	●	●		●	●	●	●					
Reduction		●	●	●	●	●	●	●	●	●	●	●	●		●	●

Specifications		Model	GX160K1												
		Type	Standard equipment (1)												
		LD	LDB1	LDB3	LDM	LD4	LH	LHB3	LHQ4	LHW	LJ	LJC7	LJD	LJG	LJS
Crankshaft	19mm Ø Straight														
	20mm Ø Straight														
	20mm Ø Spline (L=235.9)														
	20mm Ø Spline (L=248.9)	●	●	●	●	●	●	●	●	●	●	●	●	●	●
	21mm Ø Spline														
	24mm Ø Spline														
	M16 Stepped thread														
	M18 Stepped thread														
	1/2" Stepped thread														
	3/4" Thread														
	5/8" Thread														
	1/5" Tapered														
	3/4" Tapered														
Coil	Lamp coil									●					
	Charge coil														
Control box															
Starter motor															
Oil alert												●			
Reduction		●	●	●	●	●	●	●	●	●	●	●	●	●	●

Model		GX160K1														
		Standard equipment (1)														
Specifications		Type	LMT	LSJ	LSJ4	LSS	LSS1	LSS4	LTA	LTK	LVL	LW2	LX	LXU	LX2	LX26
Crankshaft	19mm Ø Straight															
	20mm Ø Straight															
	20mm Ø Spline (L=235.9)															
	20mm Ø Spline (L=248.9)	●	●	●	●	●	●	●	●	●	●	●	●	●	●	●
	21mm Ø Spline															
	24mm Ø Spline															
	M16 Stepped thread															
	M18 Stepped thread															
	1/2" Stepped thread															
	3/4" Thread															
	5/8" Thread															
	1/5" Tapered															
	3/4" Tapered															
Coil	Lamp coil				●						●					
	Charge coil					●										
Control box																
Starter motor						●										
Oil alert												●	●	●	●	
Reduction		●	●	●	●	●	●	●	●	●	●	●	●	●	●	●

Specifications		Model	GX160K1													
		Type	Standard equipment (1)													
			LX4	NJ	NJC1	NJG	NSJ	NW	PH	PHM	PHU	PM	PM2	PX	PXU	PX2
Crankshaft	19mm Ø Straight															
	20mm Ø Straight		●	●	●	●	●									
	20mm Ø Spline (L=235.9)															
	20mm Ø Spline (L=248.9)	●														
	21mm Ø Spline															
	24mm Ø Spline															
	M16 Stepped thread															
	M18 Stepped thread															
	1/2" Stepped thread															
	3/4" Thread							●	●	●	●	●	●	●	●	
	5/8" Thread															
	1/5" Tapered															
	3/4" Tapered															
Coil	Lamp coil					●										
	Charge coil															
Control box																
Starter motor																
Oil alert		●											●	●	●	
Reduction		●														

Model		GX160K1														
		Standard equipment (1)														
Specifications		Type	QA	QAB1	QAB3	QAX	QAX2	QA2	QA26	QBC2	QBT2	QBT6	QBU2	QCB2	QCL	QD
		Crankshaft	19mm Ø Straight		●	●	●	●	●	●	●	●	●	●	●	●
20mm Ø Straight																
20mm Ø Spline (L=235.9)																
20mm Ø Spline (L=248.9)																
21mm Ø Spline																
24mm Ø Spline																
M16 Stepped thread																
M18 Stepped thread																
1/2" Stepped thread																
3/4" Thread																
5/8" Thread																
1/5" Tapered																
3/4" Tapered																
Coil	Lamp coil															
	Charge coil				●	●										
Control box																
Starter motor																
Oil alert						●				●	●			●		
Reduction																

Specifications		Model	GX160K1												
		Type	Standard equipment (1)												
		QE	QFE4	QGR2	QGR9	QH	QHE	QHP1	QHQ4	QH26	QI2	QKA4	QM	QMC6	QMC8
Crankshaft	19mm Ø Straight	●	●	●	●	●	●	●	●	●	●	●	●	●	●
	20mm Ø Straight														
	20mm Ø Spline (L=235.9)														
	20mm Ø Spline (L=248.9)														
	21mm Ø Spline														
	24mm Ø Spline														
	M16 Stepped thread														
	M18 Stepped thread														
	1/2" Stepped thread														
	3/4" Thread														
	5/8" Thread														
	1/5" Tapered														
	3/4" Tapered														
Coil	Lamp coil													●	
	Charge coil				●		●					●			
Control box							●					●			
Starter motor							●					●			
Oil alert				●	●						●	●			●
Reduction															

Specifications		Model	GX160K1													
		Type	Standard equipment (1)													
			QMD6	QME4	QMH	QMX2	QMZ2	QNT	QNT2	QNT4	QNZ	QP	QPU	QSC2	QSC9	QS2
Crankshaft	19mm Ø Straight		●	●	●	●	●	●	●	●	●	●	●	●	●	●
	20mm Ø Straight															
	20mm Ø Spline (L=235.9)															
	20mm Ø Spline (L=248.9)															
	21mm Ø Spline															
	24mm Ø Spline															
	M16 Stepped thread															
	M18 Stepped thread															
	1/2" Stepped thread															
	3/4" Thread															
	5/8" Thread															
	1/5" Tapered															
	3/4" Tapered															
Coil	Lamp coil		●									●				
	Charge coil										●			●	●	
Control box														●		
Starter motor											●			●		
Oil alert			●		●	●		●		●				●	●	●
Reduction																

Specifications		Model	GX160K1												
		Type	Standard equipment (1)												
		QT	QVL	QWA4	QWM2	QWX2	QWX3	QX	QXB	QXB1	QXC	QXC6	QXC9	QXE	QXE2
Crankshaft	19mm Ø Straight	●	●	●	●	●	●	●	●	●	●	●	●	●	●
	20mm Ø Straight														
	20mm Ø Spline (L=235.9)														
	20mm Ø Spline (L=248.9)														
	21mm Ø Spline														
	24mm Ø Spline														
	M16 Stepped thread														
	M18 Stepped thread														
	1/2" Stepped thread														
	3/4" Thread														
	5/8" Thread														
	1/5" Tapered														
	3/4" Tapered														
Coil	Lamp coil														
	Charge coil													●	●
Control box														●	●
Starter motor														●	●
Oil alert				●	●	●	●	●		●	●	●	●	●	●
Reduction															

Specifications		Model	GX160K1												
		Type	Standard equipment (1)												
			QXE4	QXE6	QXE8	QXF	QXF2	QXM1	QXQ	QXS	QXS2	QXU	QXW	QXW2	QX2
Crankshaft	19mm Ø Straight	●	●	●	●	●	●	●	●	●	●	●	●	●	●
	20mm Ø Straight														
	20mm Ø Spline (L=235.9)														
	20mm Ø Spline (L=248.9)														
	21mm Ø Spline														
	24mm Ø Spline														
	M16 Stepped thread														
	M18 Stepped thread														
	1/2" Stepped thread														
	3/4" Thread														
	5/8" Thread														
	1/5" Tapered														
	3/4" Tapered														
Coil	Lamp coil							●	●						
	Charge coil	●	●	●							●	●			
Control box		●	●	●							●	●			
Starter motor		●	●	●							●	●			
Oil alert		●	●	●	●	●	●	●	●	●	●	●	●	●	●
Reduction															

Specifications		Model	GX160K1													
		Type	Standard equipment (1)													
			QX26	QX4	QX7	QZ	RAC	RD	RD4	REX4	RFR	RFR2	RH	RHA	RHA2	RHQ4
Crankshaft	19mm Ø Straight		●	●	●	●										
	20mm Ø Straight						●	●	●	●	●	●	●	●	●	●
	20mm Ø Spline (L=235.9)															
	20mm Ø Spline (L=248.9)															
	21mm Ø Spline															
	24mm Ø Spline															
	M16 Stepped thread															
	M18 Stepped thread															
	1/2" Stepped thread															
	3/4" Thread															
	5/8" Thread															
	1/5" Tapered															
	3/4" Tapered															
Coil	Lamp coil													●		
	Charge coil									●						
Control box										●						
Starter motor										●						
Oil alert			●	●	●					●						
Reduction							●	●	●	●	●	●	●	●	●	●

Specifications		Model	GX160K1													
		Type	Standard equipment (1)													
			RH2	RH26	RMB4	RMD	RMG2	RNG	RSK	RSS1	RTB2	RX	RXE	RXE2	RXE4	RXU
Crankshaft	19mm Ø Straight															
	20mm Ø Straight		●	●	●	●	●	●	●	●	●	●	●	●	●	●
	20mm Ø Spline (L=235.9)															
	20mm Ø Spline (L=248.9)															
	21mm Ø Spline															
	24mm Ø Spline															
	M16 Stepped thread															
	M18 Stepped thread															
	1/2" Stepped thread															
	3/4" Thread															
	5/8" Thread															
	1/5" Tapered															
	3/4" Tapered															
Coil	Lamp coil					●			●							
	Charge coil											●	●	●		
Control box												●	●	●		
Starter motor												●	●	●		
Oil alert												●	●	●	●	●
Reduction			●	●	●	●	●	●	●	●	●	●	●	●	●	●

Specifications		Model	GX160K1												
		Type	Standard equipment (1)												
			RX4	SAC	SAD2	SCJ	SD	SDB1	SDB3	SDN	SDS	SDS2	SDS3	SD16	SD4
Crankshaft	19mm Ø Straight														
	20mm Ø Straight	●	●	●	●	●	●	●	●	●	●	●	●	●	●
	20mm Ø Spline (L=235.9)														
	20mm Ø Spline (L=248.9)														
	21mm Ø Spline														
	24mm Ø Spline														
	M16 Stepped thread														
	M18 Stepped thread														
	1/2" Stepped thread														
	3/4" Thread														
	5/8" Thread														
	1/5" Tapered														
	3/4" Tapered														
Coil	Lamp coil									●					
	Charge coil														
Control box															
Starter motor															
Oil alert		●													
Reduction		●													

Specifications		Model	GX160K1												
		Type	Standard equipment (1)												
		SEE	SG24	SH	SHM	SHQ4	SHRY	SHR4	SJ	SJC	SJC1	SJC5	SJG	SKM	SMB4
Crankshaft	19mm Ø Straight														
	20mm Ø Straight	●	●	●	●	●	●	●	●	●	●	●	●	●	●
	20mm Ø Spline (L=235.9)														
	20mm Ø Spline (L=248.9)														
	21mm Ø Spline														
	24mm Ø Spline														
	M16 Stepped thread														
	M18 Stepped thread														
	1/2" Stepped thread														
	3/4" Thread														
	5/8" Thread														
	1/5" Tapered														
	3/4" Tapered														
Coil	Lamp coil														
	Charge coil	●												●	
Control box		●													
Starter motor		●												●	
Oil alert			●								●	●		●	
Reduction															

Specifications		Model	GX160K1												
		Type	Standard equipment (1)												
			SMC7	SMC9	SMJ	SMJ1	SMW2	SMX4	SM11	SM12	SM14	SNX	SNX1	SSK1	SSK2
Crankshaft	19mm Ø Straight														
	20mm Ø Straight	●	●	●	●	●	●	●	●	●	●	●	●	●	●
	20mm Ø Spline (L=235.9)														
	20mm Ø Spline (L=248.9)														
	21mm Ø Spline														
	24mm Ø Spline														
	M16 Stepped thread														
	M18 Stepped thread														
	1/2" Stepped thread														
	3/4" Thread														
	5/8" Thread														
	1/5" Tapered														
	3/4" Tapered														
Coil	Lamp coil		●												
	Charge coil											●			
Control box															
Starter motor												●			
Oil alert		●	●	●	●	●	●		●	●	●	●			●
Reduction															

Specifications		Model	GX160K1												
		Type	Standard equipment (1)												
		ST	STA	STM	STP	STQ	SWG4	SWX	SWX2	SWX4	SW2	SX	SXB	SXE	SXE4
Crankshaft	19mm Ø Straight														
	20mm Ø Straight	●	●	●	●	●	●	●	●	●	●	●	●	●	●
	20mm Ø Spline (L=235.9)														
	20mm Ø Spline (L=248.9)														
	21mm Ø Spline														
	24mm Ø Spline														
	M16 Stepped thread														
	M18 Stepped thread														
	1/2" Stepped thread														
	3/4" Thread														
	5/8" Thread														
	1/5" Tapered														
	3/4" Tapered														
Coil	Lamp coil			●							●				
	Charge coil	●		●										●	●
Control box														●	●
Starter motor		●		●			●							●	●
Oil alert				●			●	●	●	●		●	●	●	●
Reduction															

Specifications		Model	GX160K1													
		Type	Standard equipment (1)													
			SXS4	SXU	SX4	SX7	S1CY	TCS2	TH	THU	TX	TXC9	TXU	TX2	TX26	TX4
Crankshaft	19mm Ø Straight															
	20mm Ø Straight		●	●	●	●	●									
	20mm Ø Spline (L=235.9)															
	20mm Ø Spline (L=248.9)															
	21mm Ø Spline															
	24mm Ø Spline															
	M16 Stepped thread															
	M18 Stepped thread															
	1/2" Stepped thread															
	3/4" Thread															
	5/8" Thread							●	●	●	●	●	●	●	●	●
	1/5" Tapered															
	3/4" Tapered															
Coil	Lamp coil															
	Charge coil															
Control box																
Starter motor																
Oil alert			●	●	●	●		●			●	●	●	●	●	●
Reduction																

Specifications		Model	GX160K1													
		Type	Standard equipment (1)													
			UH	UX	UXU	VA	VA2	VEBM	VEB2	VED	VED1	VED2	VED3	VED5	VED6	VED7
Crankshaft	19mm Ø Straight															
	20mm Ø Straight															
	20mm Ø Spline (L=235.9)															
	20mm Ø Spline (L=248.9)															
	21mm Ø Spline															
	24mm Ø Spline															
	M16 Stepped thread															
	M18 Stepped thread															
	1/2" Stepped thread		●	●	●											
	3/4" Thread															
	5/8" Thread															
	1/5" Tapered							●	●	●	●	●	●	●	●	●
	3/4" Tapered					●	●									
Coil	Lamp coil															
	Charge coil															
Control box																
Starter motor																
Oil alert			●	●	●	●	●			●	●	●	●	●	●	●
Reduction																

Specifications		Model	GX160K1												
		Type	Standard equipment (1)												
		VEN2	VES	VEG4	VG24	VH	VHA7	VHH4	VHQ4	VMB3	VMS4	VMS7	VMT	VPM4	VPM5
Crankshaft	19mm Ø Straight														
	20mm Ø Straight														
	20mm Ø Spline (L=235.9)														
	20mm Ø Spline (L=248.9)														
	21mm Ø Spline														
	24mm Ø Spline														
	M16 Stepped thread														
	M18 Stepped thread														
	1/2" Stepped thread														
	3/4" Thread														
	5/8" Thread														
	1/5" Tapered	•	•		•								•		
	3/4" Tapered			•		•	•	•	•	•	•	•		•	•
Coil	Lamp coil		•												
	Charge coil														
Control box															
Starter motor															
Oil alert		•	•	•	•		•	•		•	•	•	•	•	•
Reduction															

Specifications		Model	GX160K1												
		Type	Standard equipment (1)												
		VPM7	VPR4	VPR7	VS	VSX1	VSD	VSD1	VSD7	VSG	VSW	VSX	VSX1	VSX3	VS1
Crankshaft	19mm Ø Straight														
	20mm Ø Straight														
	20mm Ø Spline (L=235.9)														
	20mm Ø Spline (L=248.9)														
	21mm Ø Spline														
	24mm Ø Spline														
	M16 Stepped thread														
	M18 Stepped thread														
	1/2" Stepped thread														
	3/4" Thread														
	5/8" Thread														
	1/5" Tapered														
	3/4" Tapered		●	●	●	●	●	●	●	●	●	●	●	●	●
Coil	Lamp coil														
	Charge coil										●				
Control box															
Starter motor											●				
Oil alert		●	●	●		●	●	●	●	●	●	●	●	●	
Reduction															

Specifications		Model	GX160K1													
		Type	Standard equipment (1)													
		VS17	VS3	VS4	VTD	VTD1	VTE2	VTU1	VTX	VTX1	VWA	VWA2	VW12	VX	VXD	
Crankshaft	19mm Ø Straight															
	20mm Ø Straight															
	20mm Ø Spline (L=235.9)															
	20mm Ø Spline (L=248.9)															
	21mm Ø Spline															
	24mm Ø Spline															
	M16 Stepped thread															
	M18 Stepped thread															
	1/2" Stepped thread															
	3/4" Thread															
	5/8" Thread															
	1/5" Tapered							●								●
	3/4" Tapered		●	●	●	●	●		●	●	●	●	●	●	●	
Coil	Lamp coil														●	
	Charge coil															
Control box																
Starter motor																
Oil alert		●	●	●	●	●		●	●	●		●	●	●	●	
Reduction																

Model		GX160K1														
		Standard equipment (1)														
Specifications		Type	VXD1	VXE	VXE4	VXE6	VXE7	VXG	VXM	VXU	VXU1	VXW	VXW1	VXW2	VX2	VX26
		Crankshaft	19mm Ø Straight													
20mm Ø Straight																
20mm Ø Spline (L=235.9)																
20mm Ø Spline (L=248.9)																
21mm Ø Spline																
24mm Ø Spline																
M16 Stepped thread																
M18 Stepped thread																
1/2" Stepped thread																
3/4" Thread																
5/8" Thread																
1/5" Tapered	●															
3/4" Tapered			●	●	●	●	●	●	●	●	●	●	●	●	●	●
Coil	Lamp coil	●														
	Charge coil		●	●	●	●										
Control box			●	●	●	●										
Starter motor			●	●	●	●										
Oil alert		●	●	●	●	●	●	●	●	●	●		●	●	●	
Reduction																

Specifications		Model	GX160K1										
		Type	Standard equipment (1)										
			VX4	WDA6	WJP	WKD6	WKT2	WKT4	WKT6	WMB0	WME2	WME4	WMT
Crankshaft	19mm Ø Straight												
	20mm Ø Straight												
	20mm Ø Spline (L=235.9)												
	20mm Ø Spline (L=248.9)												
	21mm Ø Spline												
	24mm Ø Spline												
	M16 Stepped thread			●							●	●	
	M18 Stepped thread		●		●	●	●	●	●	●			●
	1/2" Stepped thread												
	3/4" Thread												
	5/8" Thread												
	1/5" Tapered												
	3/4" Tapered		●										
Coil	Lamp coil												
	Charge coil												
Control box													
Starter motor													
Oil alert			●		●	●	●	●		●			●
Reduction													

Specifications		Model	GX160K1							
		Type	Selective equipment (2)							
		H1	L1	Q1	R1	S1	T1	U1	V1	W1
Crankshaft	19mm Ø Straight			●						
	20mm Ø Straight				●	●				
	20mm Ø Spline (L=235.9)									
	20mm Ø Spline (L=248.9)		●							
	21mm Ø Spline	●								
	24mm Ø Spline									
	M16 Stepped thread									
	M18 Stepped thread									●
	1/2" Stepped thread							●		
	3/4" Thread									
	5/8" Thread						●			
	1/5" Tapered									
3/4" Tapered								●		
Coil	Lamp coil	(●)	(●)	(●)	(●)	(●)	(●)	(●)	(●)	(●)
	Charge coil	(●)	(●)	(●)	(●)	(●)	(●)	(●)	(●)	(●)
Control box		(●)	(●)	(●)	(●)	(●)	(●)	(●)	(●)	(●)
Starter motor		(●)	(●)	(●)	(●)	(●)	(●)	(●)	(●)	(●)
Oil alert		(●)	(●)	(●)	(●)	(●)	(●)	(●)	(●)	(●)
Reduction		●	●		●					

		Model	GX160K1				GX160K1		
		Type	Indonesia-KD (3)				Propane (4)		
Specifications			QIH1	UIH	VIH1	WIH1	SXP1	VSDP	VXP
Crankshaft	19mm Ø Straight		●						
	20mm Ø Straight						●		
	20mm Ø Spline (L=235.9)								
	20mm Ø Spline (L=248.9)								
	21mm Ø Spline								
	24mm Ø Spline								
	M16 Stepped thread					●			
	M18 Stepped thread								
	1/2" Stepped thread			●					
	3/4" Thread								
	5/8" Thread								
	1/5" Tapered								
3/4" Tapered				●			●	●	
Coil	Lamp coil						●		
	Charge coil								
Control box									
Starter motor									
Oil alert				●			●	●	●
Reduction									

Fuel hose, general purpose hoses and vinyl hose

- The standard part fuel hose, general purpose hose and vinyl hose may be substituted by the coiled bulk part.
- When ordering the standard part fuel hose, general purpose hose and vinyl hose use the bulk part number written in the parts catalog in brackets () underneath the part name.
- When exchanging the hose, cut and use at the specified length as mentioned in the part name.
(For the method of cutting the bulk part, and method of filling out orders etc., please refer to the instructions issued with the bulk part.)

Bulk part number of fuel hose, general purpose hose and vinyl hose.

Example: 9 5 0 0 1 - 7 5 0 0 1 - 5 0 M

Bulk part number:
Refers to the bulk part.

Marking code (fuel hose and general purpose hose)

Change code (Vinyl hose)

Indicates number mark or change sequence, however, the code for the bulk part must be strictly 0 (zero).

Types of code:

- | | | | | | |
|-------------|--|----------------|--|--------------|---|
| • Fuel hose | 2: Red outside braid
(3 mm inside dia. only) | • General hose | 1: Ash gray
2: Ash gray
3: Black
5: Black | • Vinyl hose | 1: Clear
2: Black
3: Light red
6: Light red
7: Pale black |
| | 5: Black inside braid | | | | |
| | 3: Red (3 mm inside dia. only) | | | | |
| | 4: Ash gray with red stripe
(3 mm inside dia. only) | | | | |
| | 6: Black | | | | |

Lengths:

- 001: 1 m (standard)
003: 3 m
008: 8 m } Application or specification of some parts is not settled.

I.D code: (fuel hose and general purpose hose)

- | | | | | |
|------------|--------------------|--------------------|-----------------------------|-----------------------------|
| 30: 3.0 mm | 50: 5.0 mm | 70: 7.0 mm | 11: 11 mm | 12: 12 (outside dia. 17) mm |
| 35: 3.5 mm | 55: 5.3 mm, 5.5 mm | 75: 7.3 mm, 7.5 mm | 91: 12 (outside dia. 15) mm | 14: 14 mm |
| 45: 4.5 mm | 65: 6.5 mm | 80: 8.0 mm | 92: 12 (outside dia. 16) mm | 17: 17 mm |

ID./OD. code: (vinyl hose)

- | | | | | |
|-------------------------|--------------------------|---------------------------|---------------------------|---------------------------|
| 01: ID. 2.9, OD. 6.8 mm | 12: ID. 5.0, OD. 7.0 mm | 21: ID. 8.0, OD. 9.0 mm | 37: ID. 11.0, OD. 15.0 mm | 50: ID. 16.0, OD. 19.0 mm |
| 03: ID. 3.0, OD. 6.0 mm | 10: ID. 5.0, OD. 8.0 mm | 23: ID. 8.0, OD. 12.0 mm | 38: ID. 12.0, OD. 13.0 mm | 55: ID. 17.5, OD. 20.5 mm |
| 05: ID. 3.5, OD. 6.5 mm | 11: ID. 5.0, OD. 9.0 mm | 25: ID. 9.0, OD. 11.0 mm | 39: ID. 12.0, OD. 14.0 mm | 60: ID. 22.0, OD. 27.0 mm |
| 07: ID. 4.0, OD. 7.0 mm | 14: ID. 6.0, OD. 9.0 mm | 27: ID. 9.0, OD. 13.0 mm | 40: ID. 12.0, OD. 16.0 mm | |
| 08: ID. 4.5, OD. 6.5 mm | 17: ID. 7.0, OD. 9.0 mm | 33: ID. 10.0, OD. 14.0 mm | 43: ID. 13.0, OD. 15.0 mm | |
| 09: ID. 4.5, OD. 8.0 mm | 19: ID. 7.0, OD. 11.0 mm | 36: ID. 11.0, OD. 13.0 mm | 45: ID. 14.0, OD. 18.0 mm | |

Hose type:

- 1: Fuel hose
3: Vinyl hose
5: General hose

⊙ **CAUTION: It is DANGEROUS to confuse the fuel hose with the general purpose hose or vinyl hose.**

Never use a general purpose hose or vinyl hose in place of a fuel hose or vice versa. Always use the correct bulk part in the parts catalogue, according to the service manual or the instructions issued with the bulk part.

FLAT RATE SERVICE TIME

Flat rate service time (FRT) means the standard time required to service a product, which is listed in this manual to help the dealers control the actual working process and calculate the service charge by using it as a guide.

FRT setting system

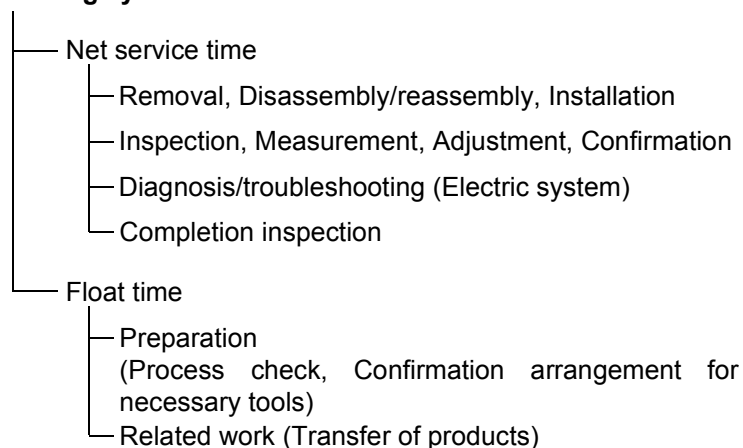

* Float time is set by multiplying the net service time by a given coefficient.

Editorial style

The service items shown in the text are listed with the exchange work time for the repair sales parts as the subject. Other representative service items not using repair parts (removal/installation, adjustment, inspection/measuring, and other work) are listed collectively in the list in the preface, classified according to the work.

FRT setting standard

- Decimal system (in unit of 0.1) is adopted to set FRT as it is convenient to calculate the wage.
Example: (0.1) → 6 minutes, (0.2) → 12 minutes
[Labor cost per hour] x [FRT] = [Wage]
- FRT is set with a hand tool.
- Service items and FRT can be subject to change depending on development of tools and service equipment and improvement in service procedure.

Work procedure

- As the work procedure is set with the work time according to the method in the separate Service Manual, refer to this Manual as required.
- Work methods permitting servicing in the shortest time still permitting assurance of safe work and product warranty are used for the setting of service items not listed in the Service Manual.
- Work basically is to be performed by one person, and when two or more people are required, setting is done as the total time for the number of people.
- The set value for the technological level of the workers uses a person with three years of experience in the repair of Honda products as the standard.
- Special tools and service equipment used to set FRT are those specified or recommended in Service Manual.

Service item whose FRT is not presented

- Accessories and service parts that are not listed to use in this manual.
 - Locations with little aging deterioration or breakage during normal use.
 - Service work that can be finished by one touch.
 - Service work that is seldom done (i.e. extremely small causes of trouble and service frequency).
 - Products and parts whose location for installation differs according to its status of use and application.
- * When FRT is not presented, please calculate wages based on appropriate actual work time.

Operation not included of FRT

- Oil and coolant water draining, Waiting time for warming up operation and etc..
- Additional operation that involves removal/installation of standard exterior equipment.
- Indirect time spent for service by visiting the customer, trade-in, and delivery.
- Indirect time required for ordering and delivery of parts.
- Cost for grease, adhesive agent, etc. used for service work.

**Explanation of FRT by using an example
(The example may differ from the actual presented items)**

Ref. No.	L.O.N.	(Relative ref. Number) Description	F.R.T.
①	1111L1	(1, 3, 4, 7) VALVE, INTAKE 4.1	②
③	1111L1A	• NOTE: OHV type • Includes: Engine removal and installation One head (intake all) add 1.4	⑦ ⑥ ⑤

- ① Reference No. of the illustration of part that shows location of the replacement work.
- ② FRT is an abbreviation of Flat Rate Time indicating the standard service time required for the replacement.
- ③ LON is an abbreviation of Labor Operation Number, and it is a classification of the service items by the work unit code.

The same operation code is used regardless of the models.

Standard operation is indicated with 6 digits code, and additional operation is indicated with 7 digits code.

- ④ Indicating the intake valve replacement and FRT4.1.
- ⑤ Indicating FRT1.4 that will be added when additional operation (whole intake side of one cylinder head) is done in association with intake valve replacement.

- ⑥ Indicating work condition or application condition of the service item.
- ⑦ Indicating work contents that are included in the service item.
- ⑧ Indicating a reference No. whose operation and time are the same as FRT4.1 for the intake valve.

(The application range is limited to the service items without an LON setting within a same block.)

**How to refer to the service item by using the sample
(intake valve replacement)**

Open to the page of the block where the intake valve's spare part illustration is shown.

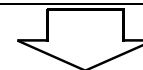

Look for the intake valve illustration, and refer to the service item and FRT that agree with the reference No.

Indication mark for the listing of service items that continues to the following page

Ref. No.	L.O.N.	(Relative ref. Number) Description	F.R.T.
2	1111L1	VALVE, INTAKE	4.1
	.	.	.
	.	.	.

+

Mark indicated at the last line.

Indication of the block with no setting of FRT

Ref. No.	L.O.N.	(Relative ref. Number) Description	F.R.T.
NO INFORMATION			

• LON code system

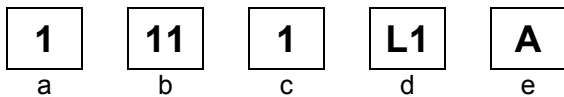

- a) Category code..... Engine
- b) Location/function code Engine upper
- c) Operation code..... Replace
- d) Operation sequence number (Unit code can be shown with alphabet)
..... Intake valve
(No regular rule of code)
- e) Additional code One head (intake all)
(No regular rule of code)

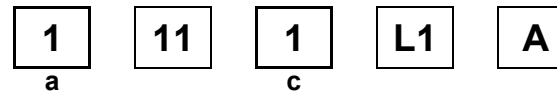

a) Category codes and classification

Code	Category
1	Engine
2	Power drive
3	Fuel & Exhaust
4	Frame & Body
5	Steering
6	Electrical
7	Axle & Brake
8	Control system
9	-
0	Attachments

c) Operation codes and classification

Code	Operation category
1	Replace, Removal/Installation, Change
2	Overhaul
3	Adjust, Rotation
4	(Paint-related work: Top-coat)
5	Test, Inspect/diagnose, Measurement
6	(Overhaul-related work: Rebore)
7	(Overhaul-related work: Reseal)
8	(Resurface)
9	(Paint-related work: Refinish)
0	Repair, Cleaning, Air bleeding

Major service items without using spare parts

(1) Removal/Installation, (2) Adjustment, (3) Inspection/Measurement, (4) Overhaul, (5) Other work

E: Engine, T: Transmission, D: Drive system, B: Body and related parts

(1) Removal/Installation

Set with the parts configuration in the status of being removed from the product.

	LON	DESCRIPTION	FRT
E	1111L3	CYLINDER HEAD ASSEMBLY-REMOVAL/INSTALLATION	0.5

(2) Adjustment

	LON	DESCRIPTION	FRT
E	1113A1	VALVE CLEARANCE-ADJUSTMENT NOTE: For 1 product	0.3
	1163A0	CONTROL, THROTTLE/GOVERNOR-ADJUSTMENT	0.2
	3113A2	CARBURETOR IDLE-ADJUSTMENT	0.2

(3) Inspection, Measurement, Cleaning

	LON	DESCRIPTION	FRT
E	1105A0	ENGINE OIL-INSPECTION	0.1
	3120A0	AIR CLEANER-CLEANING INCLUDES: Air cleaner-inspection	0.1
	3130A0	SPARK ARRESTER-CLEANING	0.2
	6140A0	SPARK PLUG-CLEANING INCLUDES: Spark plug gap-adjustment NOTE: For 1 product	0.2
	6145A0	SPARK-TEST NOTE: All cylinders	0.1

(4) Overhaul

Work condition: The required Measurements, inspections, adjustments, and cleaning/washing of each part are performed, including the main body removal/installation work and the replacement of defective parts.

	LON	DESCRIPTION	FRT
E	3112A0	CARBURETOR-OVERHAUL INCLUDES: All necessary adjustment	0.6

(5) Other work

	LON	DESCRIPTION	FRT
E	1101E1	ENGINE OIL-CHANGE INCLUDES: Engine oil-inspection	0.1

ENGINE GROUP

D16

E-2

CYLINDER HEAD

F 1

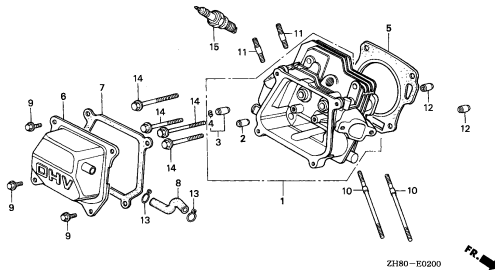

Z180-E0200

E-3

CYLINDER BARREL

F 9

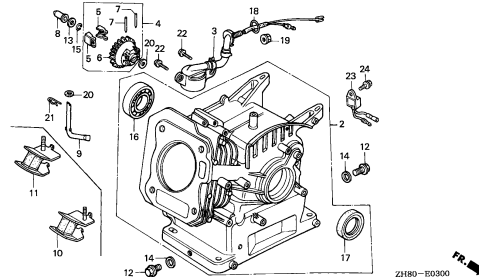

Z180-E0300

E-6

CRANKCASE COVER(1)

G 7

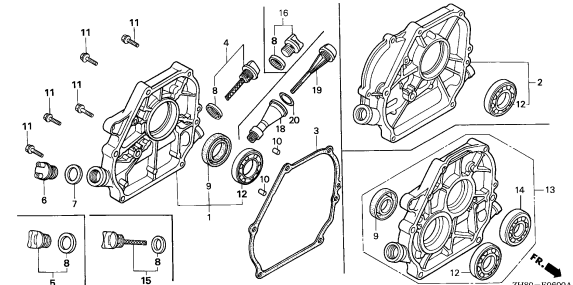

Z180-E0600A

E-6-1

CRANKCASE COVER(2)

H 3

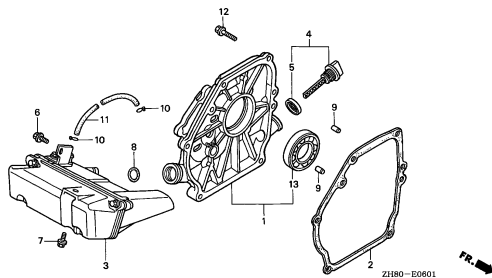

Z180-E0801

E-6-2

CRANKCASE COVER(3)

H 4

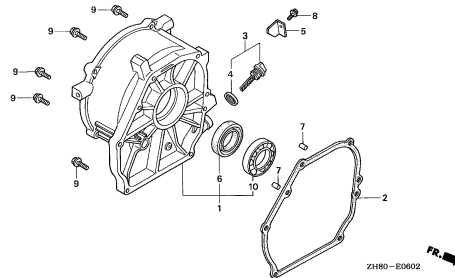

Z180-E0802

E-7

CRANKSHAFT(1)

H 5

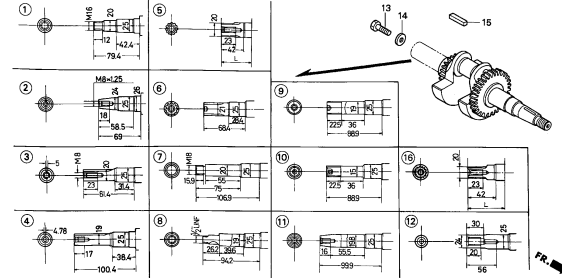

Z180-E0700B

E-7-1

CRANKSHAFT(2)

H 7

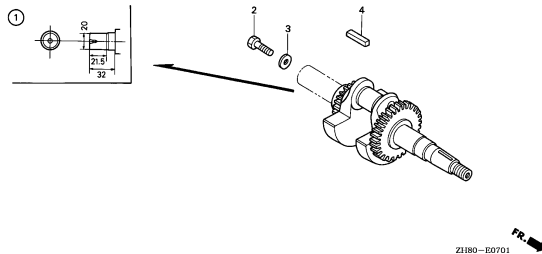

Z180-E0701

E-8

PISTON

H 8

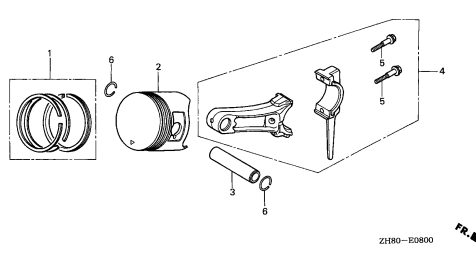

Z180-E0800

E-9

CAMSHAFT

I15

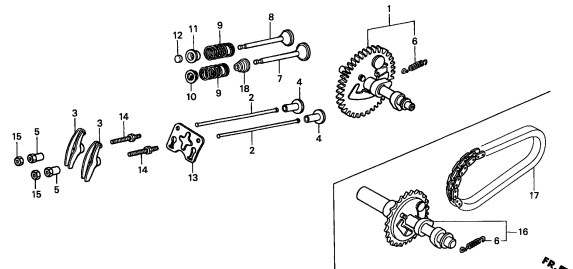

Z180-E0900A

2

ENGINE GROUP

E 1

E-11

RECOIL STARTER(1)

J 3

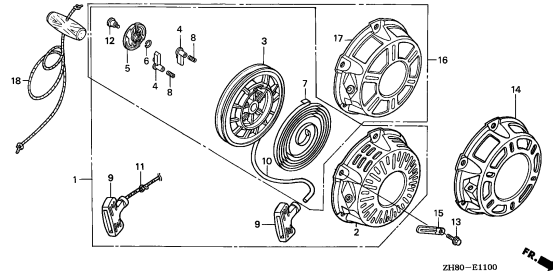

E-11-1

RECOIL STARTER(2)

J13

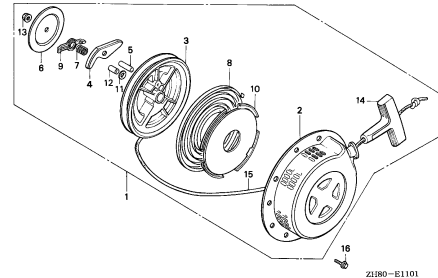

E-11-2

RECOIL STARTER(3)

J15

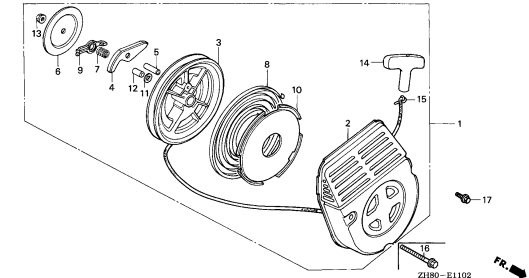

E-12

FAN COVER

J16

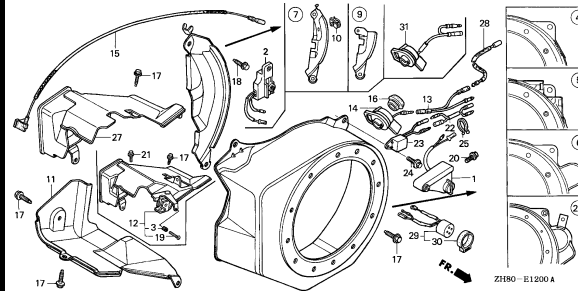

E-14

CARBURETOR(1)

K11

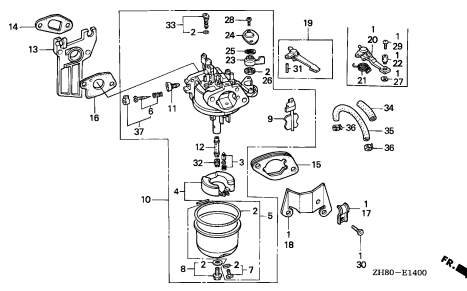

E-14-1

CARBURETOR(2)

L 1

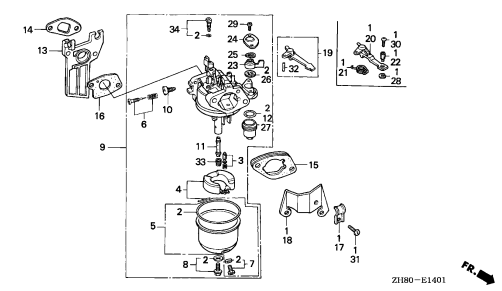

E-14-2

CARBURETOR(3)

L 3

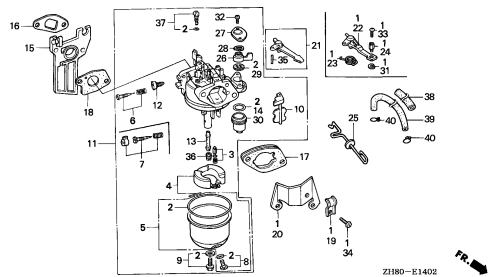

E-14-3

CARBURETOR(4)

M12

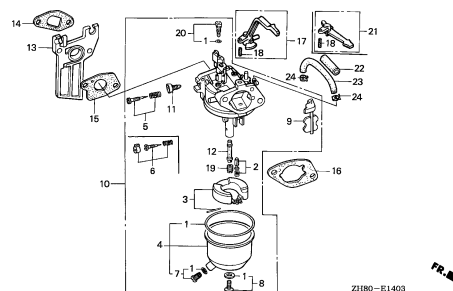

E-14-4

CARBURETOR(5)

M15

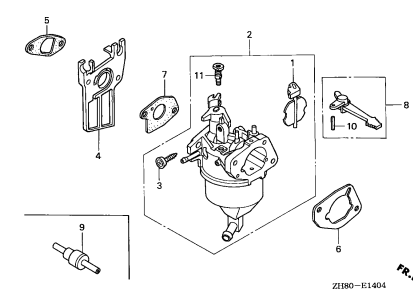

2

ENGINE GROUP

E 2

E-14-5

CARBURETOR(6)

M16

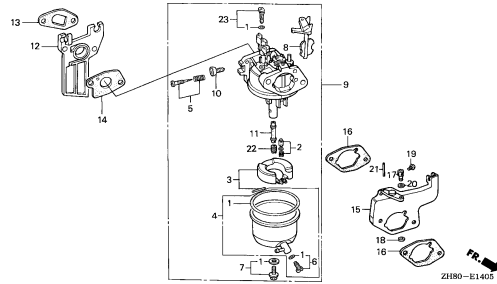

E-15

AIR CLEANER(1)

N 1

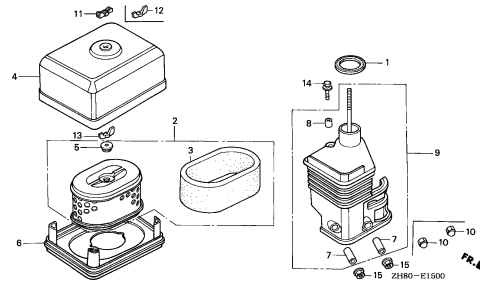

E-15-1

AIR CLEANER(2)

N 9

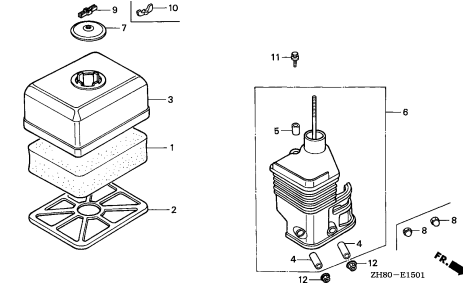

E-15-2

AIR CLEANER(3)

N11

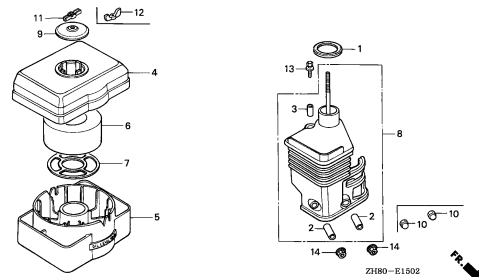

E-15-3

AIR CLEANER(4)

N13

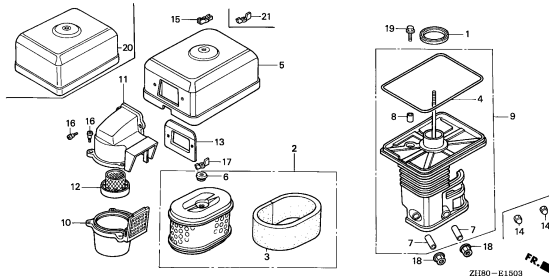

E-15-4

AIR CLEANER(5)

N15

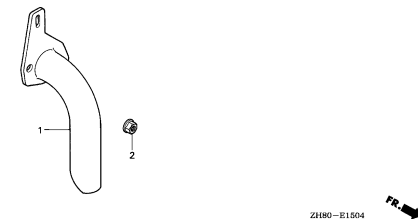

E-15-5

AIR CLEANER(6)

N16

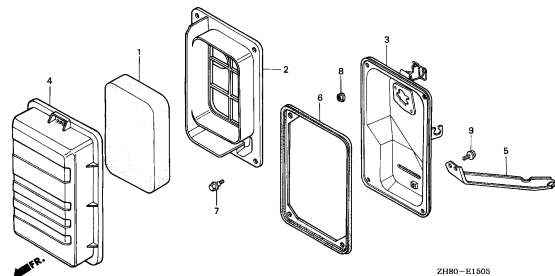

E-15-6

AIR CLEANER(7)

2-B 1

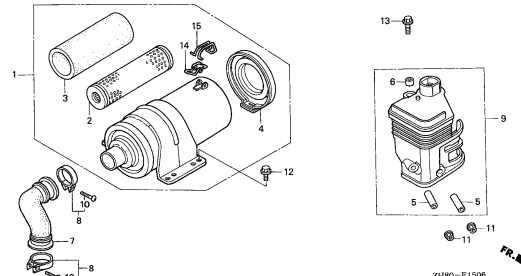

E-15-7

AIR CLEANER(8)

2-B 2

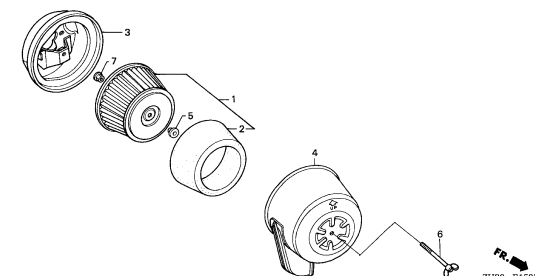

2

ENGINE GROUP

E 3

E-16

MUFFLER(1)

2-B 3

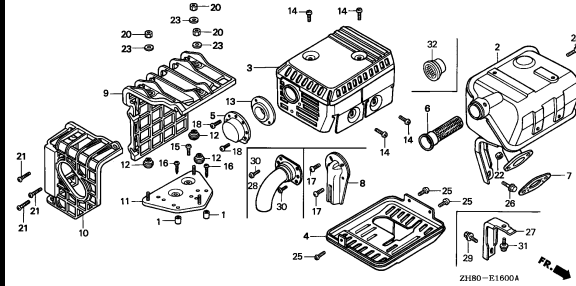

E-16-1

MUFFLER(2)

2-B11

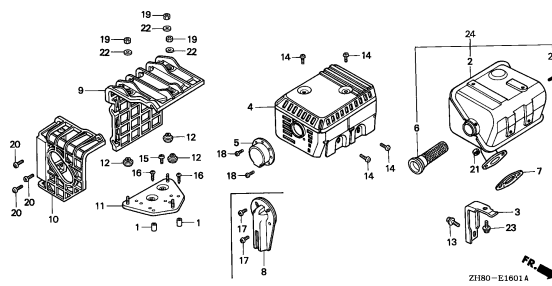

E-16-2

MUFFLER(3)

2-B13

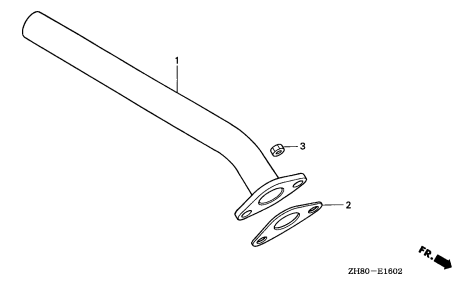

E-16-3

MUFFLER(4)

2-B14

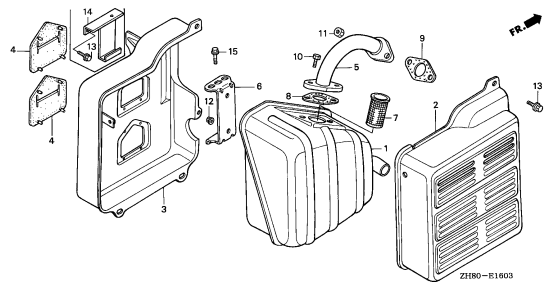

E-16-4

MUFFLER(5)

2-B16

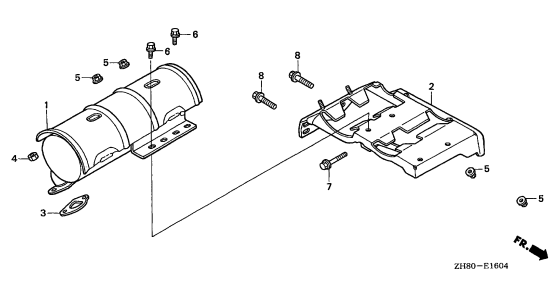

E-16-5

MUFFLER(6)

2-C 1

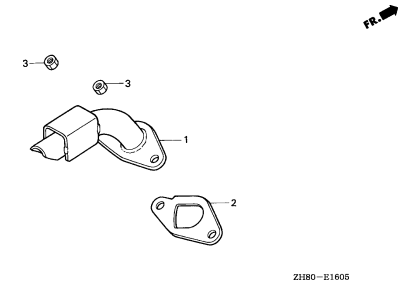

E-16-6

MUFFLER(7)

2-C 2

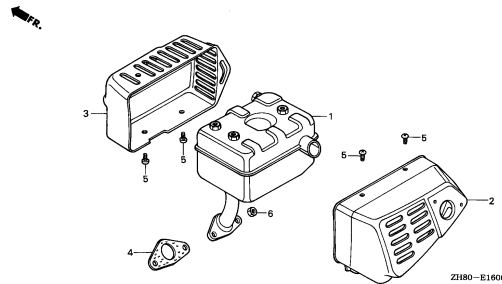

E-16-7

MUFFLER(8)

2-C 3

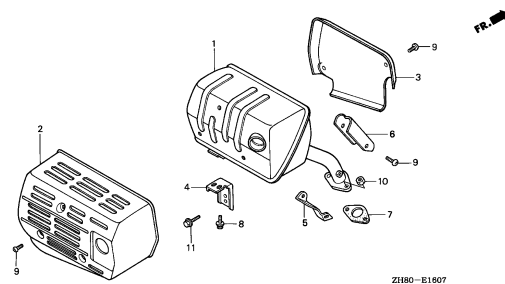

E-16-8

MUFFLER(9)

2-C 4

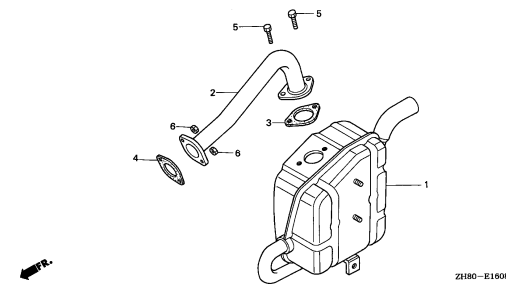

2

ENGINE GROUP

E 4

E-17

FUEL TANK(1)

2-C 5

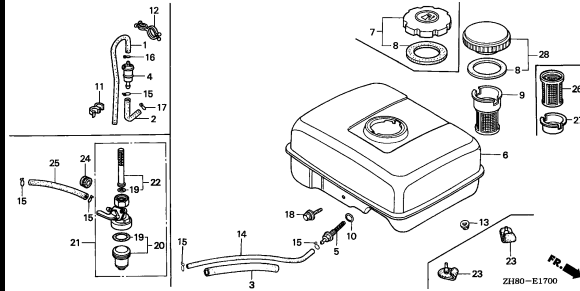

E-17-1

FUEL TANK(2)

2-C 7

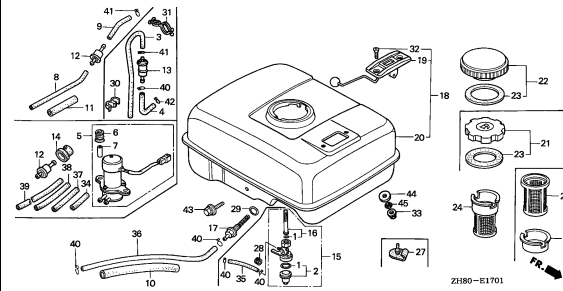

E-17-2

FUEL TANK(3)

2-C 12

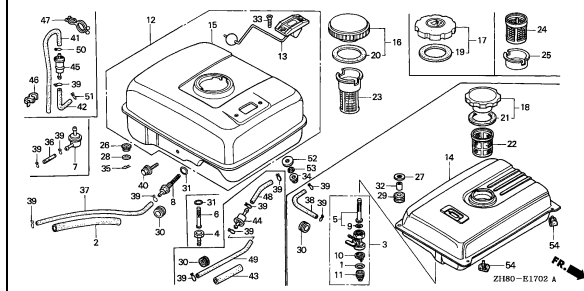

E-17-3

FUEL TANK(4)

2-D 5

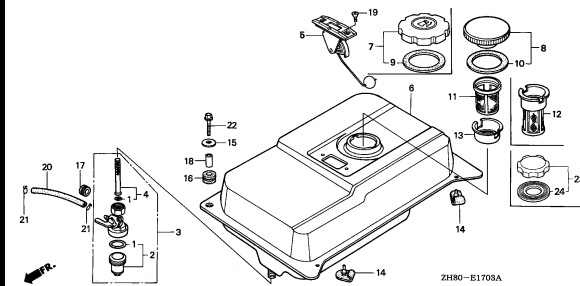

E-17-4

FUEL TANK(5)

2-D 7

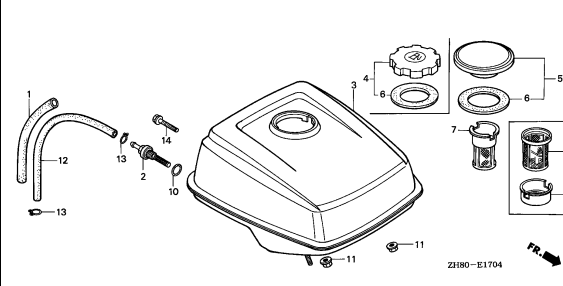

E-17-5

FUEL TANK(6)

2-D 8

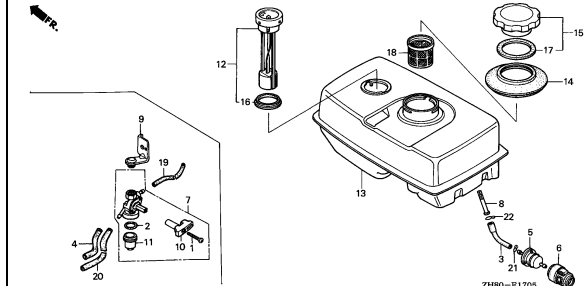

E-19

FLYWHEEL

2-D 9

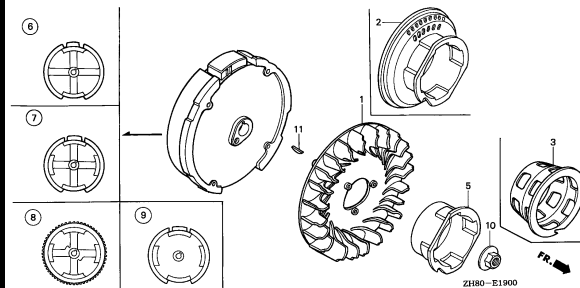

E-20

IGNITION COIL

2-D 12

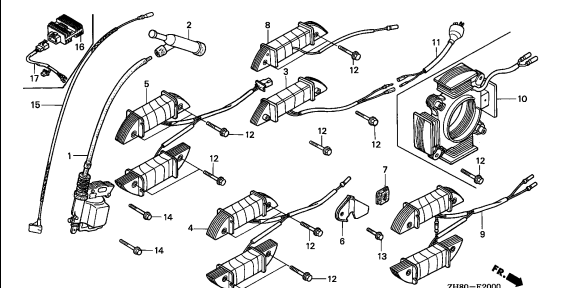

E-21

STARTER MOTOR

2-E 1

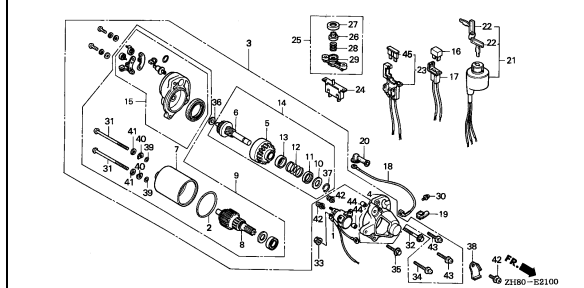

2

ENGINE GROUP

E 5

E-22

CONTROL(1)

2-E 7

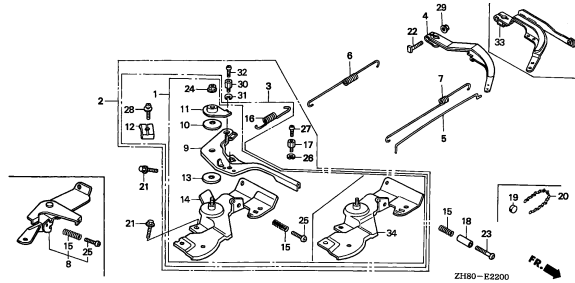

E-22-1

CONTROL(2)

2-F14

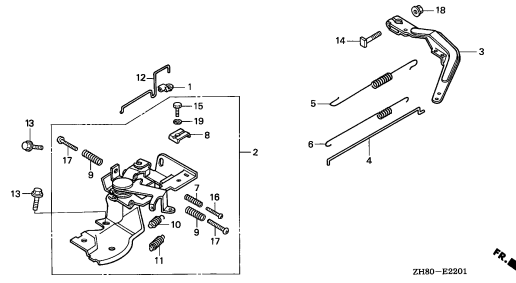

E-23

CONTROL BOX(1)

2-F15

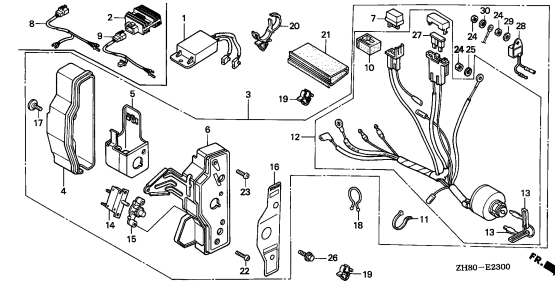

E-23-1

CONTROL BOX(2)

2-G 2

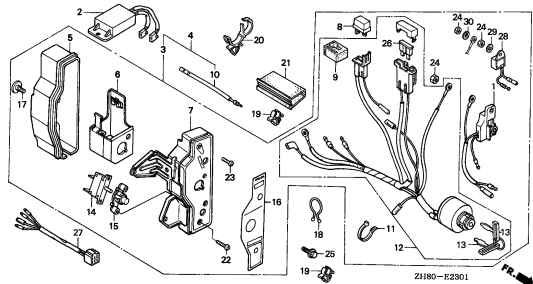

E-23-2

CONTROL CASE/ENGINE SWITCH

2-G 6

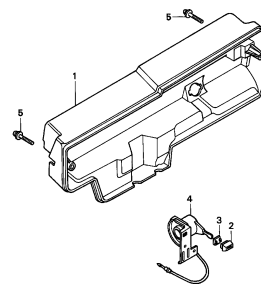

E-26

REDUCTION(1)

2-G 7

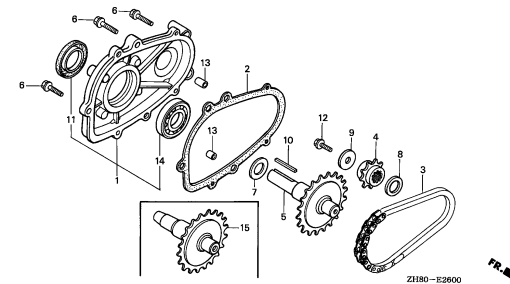

E-26-1

REDUCTION(2)

2-G 9

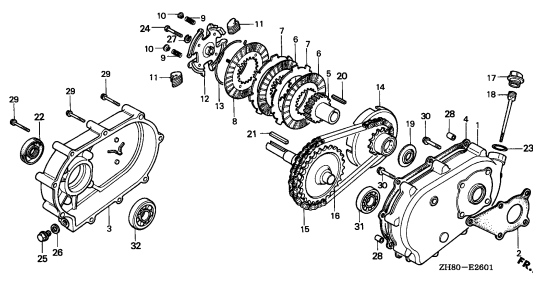

E-26-2

REDUCTION(3)

2-G11

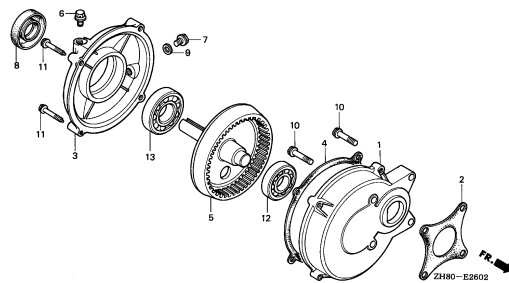

E-26-3

REDUCTION(4)

2-G12

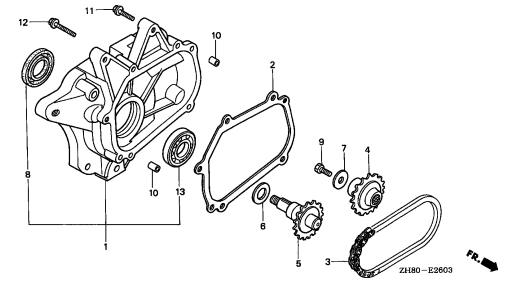

2

ENGINE GROUP

E 6

E-26-4

REDUCTION(5)

2-G13

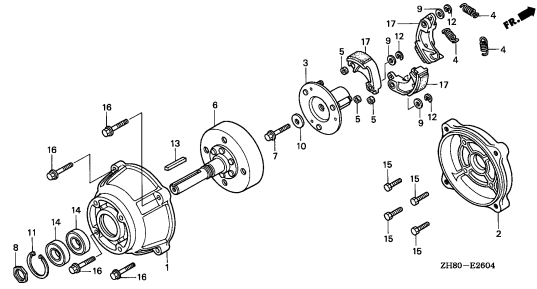

E-28

LABEL(1)

2-G14

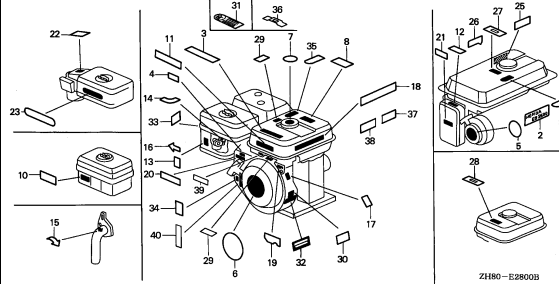

E-28-1

LABEL(2)

2-H 7

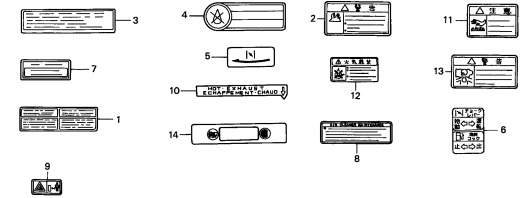

E-29

TOOL

2-H 8

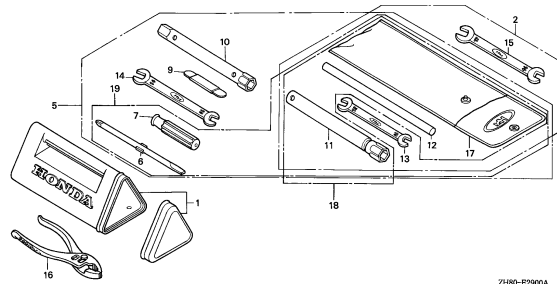

E-40

ENGINE STOP SWITCH

2-H11

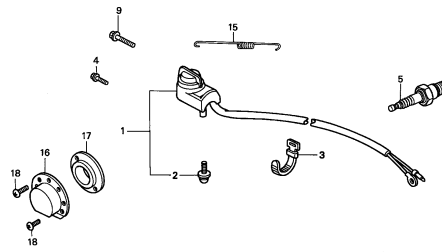

E-40-1

TRANSMISSION CASE

2-H12

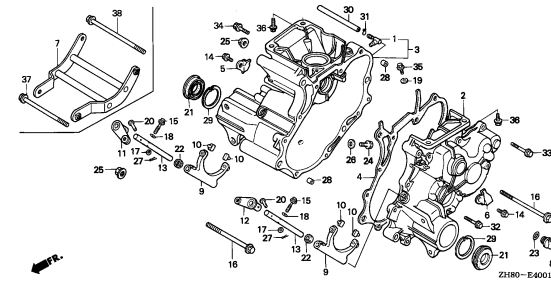

E-40-2

TRANSMISSION GEAR

2-H14

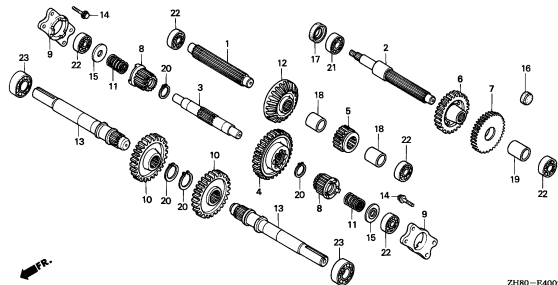

E-40-3

HYDROSTATIC TRANSMISSION

2-H15

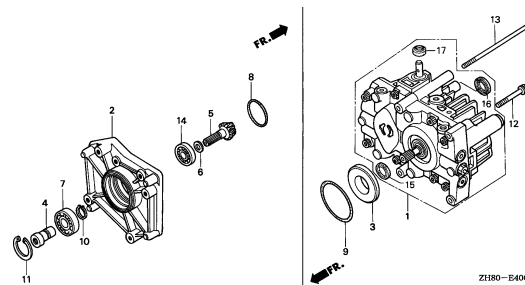

E-40-4

OIL TANK/BRAKE PANEL

2-H16

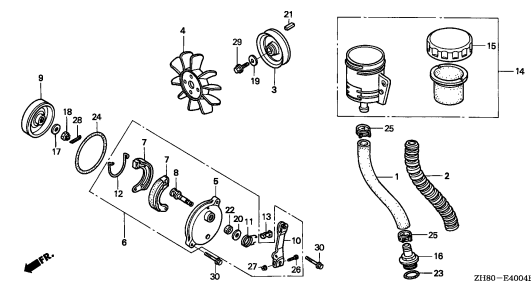

2

ENGINE GROUP

E 7

E-40-5

COMBINATION SWITCH

2-1 2

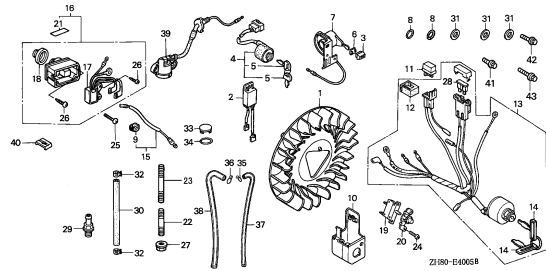

EOP-1

GASKET KIT

2-1 5

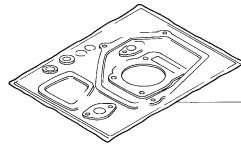

2

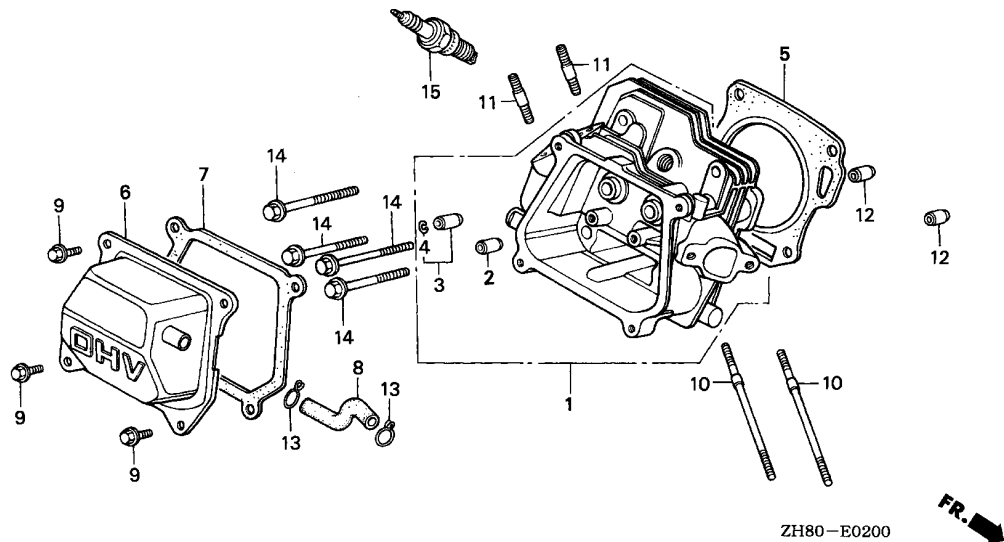

Ref. No.	L.O.N.	(Relative ref. Number) Description	F.R.T.
1	1111N3	HEAD, CYLINDERINCLUDES: Valve clearance adjustment and reface	0.9
2	1111E9	GUIDE, INTAKE VALVE	0.8
	1111E9E	.With intake and exhaust all add	0.2
3	1111E8	GUIDE, EXHAUST VALVE	0.8
	1111E8E	.With intake and exhaust all add	0.2
5	1111N4	GASKET, CYLINDER HEAD	0.5
6	1111D5	COVER, CYLINDER HEAD AND/OR PACKING, HEAD COVER	0.1
8	1111K5	TUBE, BREATHER	0.1
10	1111A5	BOLT, STUD :INTAKE	0.2
	1111A5A	.For two add	0.1
11	1111A6	BOLT, STUD :EXHAUST	0.2
	1111A6A	.For two add	0.1
15	6141C1	PLUG, SPARK	0.1

Ref. No.	Part No.	Description	Reqd. QTY				Serial No.	Parts catalogue code
			(1)	(2)	(3)	(4)		
			GX160K1					
1	12210-ZH8-020	HEAD COMP., CYLINDER	1	1	1	1		
2	12204-ZE1-306	GUIDE, IN. VALVE (O.S.)	(1)	(1)	(1)	(1)		
3	12205-ZE1-315	GUIDE, EX. VALVE (O.S.)	(1)	(1)	(1)	(1)		
4	12216-ZE5-300	CLIP, VALVE GUIDE	1	1	1	1		
5	12251-ZF1-800	GASKET, CYLINDER HEAD	1	(1)	1	1		

Ref. No.	Part No.	Description	Reqd. QTY				Serial No.	Parts catalogue code
			(1)	(2)	(3)	(4)		
6	12310-ZE1-010	COVER COMP., HEAD	1	(1)	-	1	-----	DS,DSP,EMA,EN,ET,ETX,HG1,H1,LAX,LAX2,LDB1,LDB3,LDM,LD4,LHW,LJD LMT,LSJ,LSS,LSS1,LTA,LTK,NW,PH,PHU,PM,PM2,PX,FX2,QA,QAX,QBT2 QBU2,QNT2,QWM2,QWX3,QXB,QXB1,QXF,QXS,QZ,Q1,RAC,REX4,RFR,RHA RNG,R1,SAC,SAD2,SDB1,SDN,SDS2,SDS3,SEE,SJC,SMB4,SSK2,STA,STP SWX,SW2,SXB,S1,TH,THU,T1,U1,VA,VEB2,VED7,VH,VHQ4,VS,VSDP,VSW VS1,VTD1,VTE2,VTX,VWA,VXD1,VXE,VXE6,VXG,VXW,VXW1,VX26,V1,W1 AR,ARC6,BL,EMA2,HG12,HH,HHQ4,HH26,HX,HXE,HXE8,HXU,HX2,HX26,HX4 KR,KTA,LD,LH,LHB3,LHQ4,LJ,LJC7,LJG,LJS,LSJ4,LW2,LX,LXU,LX2 LX26,LX4,L1,NJ,NJC1,NJG,NSJ,PHM,PXU,QAB1,QAB3,QAX2,QA2,QA26 QBT6,QCB2,QCL,QD,QE,QFE4,QGR2,QGR9,QH,QHE,QHP1,QHQ4,QH26,QI2 QKA4,QM,QMC6,QMC8,QMD6,QME4,QMH,QMX2,QMZ2,QNT,QNZ,QP,QPU,QT QWA4,QWX2,QX,QXE,QXE2,QXE4,QXE6,QXE8,QXF2,QXM1,QXS2,QXU,QXW QXW2,QX2,QX22,QX26,QX4,RD,RD4,RFR2,RH,RHA2,RHQ4,RH2,RH26,RMB4 RMD,RMG2,RSK,RSS1,RTB2,RX,RXE,RXE4,RXU,RX4,SCJ,SD,SDB3,SDS SD16,SD4,SE,SG24,SH,SHM,SHQ4,SHRY,SHR4,SJ,SJC1,SJC5,SJG,SKM SMC7,SMC9,SMJ,SMJ1,SMW2,SMX4,SM11,SM12,SM14,SNX,SNX1,SSK1,SSX2 ST,STM,STQ,SWG4,SWX2,SWX4,SX,SXE,SXE4,SXS4,SXU,SX4,S1CY,TCS2 TX,TXU,TX2,TX26,TX4,UH,UX,UXU,VA2,VEBM,VED,VED1,VED2,VED3,VED5 VED6,VGE4,VG24,VHH4,VMB3,VMS4,VMT,VPM4,VPR4,VS1,VSD,VSD1,VSX VSX1,VSX3,VS3,VS4,VTD,VTU1,VTX1,VWA2,VW12,VX,VXD,VXE4,VXM,VXU VXU1,VXW2,VX2,VX4,WDA6,WJP,WKD6,WKT2,WKT4,WMB0,WME2,WME4,WMT
			-	-	1	-		
			-	-	-	1	-----	2000218
	12310-ZE1-020	1	(1)	-	-	-----	7638543
							-----	SXP1,VXP AR,ARC6,BL,EMA2,HG12,HH,HHQ4,HH26,HX,HXE,HXE8,HXU,HX2,HX26,HX4 KR,KTA,LD,LH,LHB3,LHQ4,LJ,LJC7,LJG,LJS,LSJ4,LW2,LX,LXU,LX2 LX26,LX4,L1,NJ,NJC1,NJG,NSJ,PHM,PXU,QAB1,QAB3,QAX2,QA2,QA26 QBT6,QCB2,QCL,QD,QE,QFE4,QGR2,QGR9,QH,QHE,QHP1,QHQ4,QH26,QI2 QKA4,QM,QMC6,QMC8,QMD6,QME4,QMH,QMX2,QMZ2,QNT,QNZ,QP,QPU,QT QWA4,QWX2,QX,QXE,QXE2,QXE4,QXE6,QXE8,QXF2,QXM1,QXS2,QXU,QXW QXW2,QX2,QX22,QX26,QX4,RD,RD4,RFR2,RH,RHA2,RHQ4,RH2,RH26,RMB4 RMD,RMG2,RSK,RSS1,RTB2,RX,RXE,RXE4,RXU,RX4,SCJ,SD,SDB3,SDS SD16,SD4,SE,SG24,SH,SHM,SHQ4,SHRY,SHR4,SJ,SJC1,SJC5,SJG,SKM SMC7,SMC9,SMJ,SMJ1,SMW2,SMX4,SM11,SM12,SM14,SNX,SNX1,SSK1,SSX2 ST,STM,STQ,SWG4,SWX2,SWX4,SX,SXE,SXE4,SXS4,SXU,SX4,S1CY,TCS2 TX,TXU,TX2,TX26,TX4,UH,UX,UXU,VA2,VEBM,VED,VED1,VED2,VED3,VED5 VED6,VGE4,VG24,VHH4,VMB3,VMS4,VMT,VPM4,VPR4,VS1,VSD,VSD1,VSX VSX1,VSX3,VS3,VS4,VTD,VTU1,VTX1,VWA2,VW12,VX,VXD,VXE4,VXM,VXU VXU1,VXW2,VX2,VX4,WDA6,WJP,WKD6,WKT2,WKT4,WMB0,WME2,WME4,WMT VPM7,VPR7,VSD7,VSG,VS17,VXE7,WKT6
			-	-	-	1	-----	2000219
	12310-ZE1-841	COVER COMP., HEAD (BREATHER TUBE)	1	-	-	-	-----	HXQ,LSS4,QXQ
			1	-	-	-	-----	7664036
			-	(1)	-	-		QNT4,QSC2,QSC9,QXC,QXC6,QXC9,TXC9
	12310-ZE1-842	1	-	-	-	-----	7664037
							-----	QNT4,QSC2,QSC9,QXC,QXC6,QXC9,TXC9
7	12391-ZE1-000	PACKING, HEAD COVER	1	1	1	1		



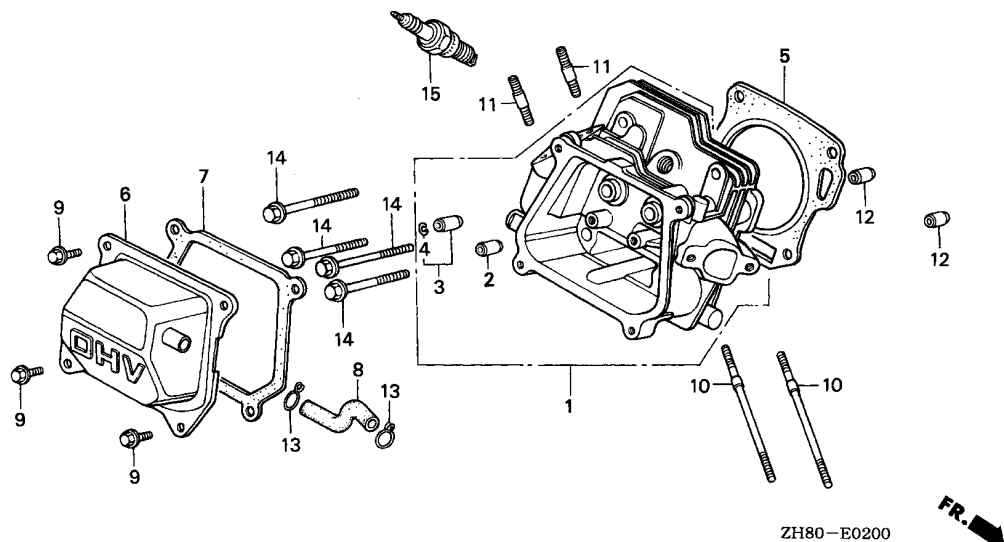

ZH80-E0200



Ref. No.	Part No.	Description	Reqd. QTY				Serial No.	Parts catalogue code
			(1)	(2)	(3)	(4)		
8	15721-ZH8-000	TUBE, BREATHER	1	-	-	-	AR, ARC6, BL, DS, DSP, EN, ET, ETX, HG1, HG12, HH, HHQ4, HH26, HX, HXE, HXE2, HXE8, HXU, HX2, HX26, HX4, KR, KTA, LAX, LAX2, LD, LDB1, LDB3, LDM, LD4, LH, LHB3, LHQ4, LHW, LJ, LJC7, LJD, LJG, LJS, LMT, LSJ, LSJ4, LSS, LSS1, LTA, LTK, LVL, LW2, LX, LXU, LX2, LX26, LX4, NJ, NJG, NSJ, NW, PH, PHM, PHU, PM, PM2, PX, PXU, PX2, QA, QAB1, QAB3, QAX, QAX2, QA2, QA26, QBC2, QBT2, QBT6, QBU2, QCB2, QCL, QD, QE, QFE4, QGR2, QGR9, QH, QHE, QHP1, QHQ4, QH26, QI2, QKA4, QM, QMC6, QMC8, QMD6, QME4, QMH, QMX2, QMZ2, QNT, QNT2, QNZ, QP, QPU, QS2, QT, QVL, QWA4, QWM2, QWX2, QWX3, QX, QXB, QXB1, QXE, QXE2, QXE4, QXE6, QXE8, QXF, QXF2, QXM1, QXS, QXS2, QXU, QXW, QXW2, QX2, QX22, QX26, QX4, QX7, RAC, RD, RD4, REX4, RFR, RFR2, RH, RHA, RHA2, RHQ4, RH2, RH26, RMB4, RMD, RMG2, RNG, RSK, RSS1, RTB2, RX, RXE, RXE2, RXE4, RXU, RX4, SAC, SAD2, SCJ, SD, SDB1, SDB3, SDN, SDS, SDS2, SDS3, SD16, SD4, SE, SEE, SG24, SH, SHM, SHQ4, SHRY, SHR4, SJ, SJC, SJC1, SJC5, SJG, SKM, SMB4, SMC7, SMC9, SMJ, SMJ1, SMW2, SMX4, SM11, SM12, SM14, SNX, SNX1, SSK1, SSK2, SSS2, ST, STA, STM, STP, STQ, SWG4, SWX, SWX2, SWX4, SW2, SX, SXB, SXE, SXE4, SXS4, SXU, SX4, SX7, S1CY, TCS2, TH, THU, TX, TXU, TX2, TX26, TX4, UH, UX, UXU, VA, VA2, VEBM, VEB2, VED, VED1, VED5, VED6, VGE4, VG24, VH, VHA7, VHH4, VHQ4, VMB3, VMS4, VMS7, VS, VSD, VSD7, VSX, VSX1, VSX3, VS1, VTD, VTD1, VTU1, VWA, VWA2, VW12, VX, VXD, VXD1, VXE, VXE4, VXE6, VXE7, VVG, VXM, VXU, VXU1, VXX, VXX1, VXX2, VX26, VX4, WDA6, WJP, WKD6, WKT2, WKT4, WKT6, WMBO, WME2, WME4, WMT	
	15721-883-030	1	(1)	1	-	EMA, EMA2, VED2, VED3, VED7, VEN2, VES, VMT, VPM4, VPM5, VPM7, VPR4, VPR7, VSB1, VSD1, VSG, VSW, VS17, VS3, VS4, VTE2, VTX, VTX1	
	15721-ZE1-710	1	-	-	-	QZ	
	15721-ZE1-840	1	-	-	-	HXQ, LSS4, QNT4, QSC2, QSC9, QXC, QXC6, QXC9, QXQ, TXC9	
	15721-ZH8-D60	1	(1)	-	-	NJC1	

Ref. No.	Part No.	Description	Reqd. QTY				Serial No.	Parts catalogue code
			(1)	(2)	(3)	(4)		
9	90016-ZE1-000	BOLT, FLANGE, 6X13(CT200) ...	4	-	-	-	-----	HXQ,HX2,LX2,PX2,QA2,QXE2,QXF2,QXQ,QXS2,QX2,RH2,TX2,VSX1,VXW2 VX2
			4	-	-	-	-----	2708336 DS,DSP,EN,ET,ETX,HG1,HH,HX,KTA,LD,LH,LJ,LJS,LMT,LTA,LTk,LW2,LX PH,PM,PM2,PX,QA,QD,QE,QH,QHE,QM,QNT,QT,QX,QXB,QXC,QXE,QXF,QXS QXW,QZ,RAC,RD,RFR,RH,RX,RXE,SAC,SCJ,SD,SDS,SE,SEE,SH,SJ,SKM SMJ,SMJ1,ST,STA,STP,STQ,SWX,SW2,SX,AXB,SXE,TH,TX,UH,UX,VA,VEBM VED,VED1,VED2,VH,VS,VSD,VSD1,VSX,VS1,VS3,VS4,VVA,VX,VXE,VXW
90013-883-000	BOLT, FLANGE, 6X12(CT200)	-	4	-	-	-----	2708336
			4	-	-	-	-----	AR,ARC6,BL,EMA,EMA2,HG12,HHQ4,HH26,HXE,HXE2,HXE8,HXU,HX26,HX4 KR,LAX,LAX2,LDB1,LDB3,LDM,LD4,LHB3,LHQ4,LHW,LJC7,LJD,LJG,LSJ LSJ4,LSS,LSS1,LSS4,LVL,LXU,LX26,LX4,NJ,NJC1,NJG,NSJ,NW,PHM,PHU PXU,QAB1,QAB3,QAX,QAX2,QA26,QBC2,QBT2,QBT6,QBU2,QCB2,QCL,QFE4 QGR2,QGR9,QHP1,QHQ4,QH26,QI2,QKA4,QMC6,QMC8,QMD6,QME4,QMH,QMX2 QMZ2,QNT2,QNT4,QNZ,QP,QPU,QSC2,QSC9,QS2,QVL,QWA4,QWM2,QWX2 QWX3,QXB1,QXC6,QXC9,QXE4,QXE6,QXE8,QXM1,QXU,QXW2,QX22,QX26,QX4 QX7,RD4,REX4,RFR2,RHA,RHA2,RHQ4,RH26,RMB4,RMD,RMG2,RNG,RSK RSS1,RTB2,RXE2,RXE4,RXU,RX4,SAD2,SDB1,SDB3,SDN,SDS2,SDS3,SD16 SD4,SG24,SHM,SHQ4,SHRY,SHR4,SJC,SJC1,SJC5,SJG,SMB4,SMC7,SMC9 SMW2,SMX4,SM11,SM12,SM14,SNX,SNX1,SSK1,SSK2,SSX2,STM,SWG4,SWX2 SWX4,SXE4,SXS4,SXU,SX4,SX7,S1CY,TCS2,THU,TCX9,TXU,TX26,TX4,UXU VA2,VEB2,VED3,VED5,VED6,VED7,VEN2,VES,VGE4,VG24,VHA7,VHH4,VHQ4 VMB3,VMS4,VMS7,VMT,VPM4,VPM5,VPM7,VPR4,VPR7,VS1,VSD7,VSG,VSW VSX3,VS17,VTD,VTD1,VTE2,VTU1,VTX,VTX1,VWA2,VW12,VXD,VXD1,VXE4 VXE6,VXE7,VXG,VXM,VXU,VXU1,VXW1,VX26,VX4,WDA6,WJP,WKD6,WKT2 WKT4,WKT6,WMB0,WME2,WME4,WMT
10	90043-ZB2-003	BOLT, STUD, 6X94	-	4	-	-	-----	2708337
			2	-	-	-	-----	DS,DSP,EN,ET,ETX,HG1,HH,HX,KTA,LD,LH,LJ,LJS,LMT,LTA,LTk,LW2,LX PH,PM,PM2,PX,QA,QD,QE,QH,QHE,QM,QNT,QT,QX,QXB,QXC,QXE,QXF,QXS QXW,QZ,RAC,RD,RFR,RH,RX,RXE,SAC,SCJ,SD,SDS,SE,SEE,SH,SJ,SKM SMJ,SMJ1,ST,STA,STP,STQ,SWX,SW2,SX,AXB,SXE,TH,TX,UH,UX,VA,VEBM VED,VED1,VED2,VH,VS,VSD,VSD1,VSX,VS1,VS3,VS4,VVA,VX,VXE,VXW
90043-ZE1-020	BOLT, STUD, 6X112	-	4	-	-	-----	2708337
			2	-	-	-	-----	EMA,EMA2,NJC1,QZ,VED2,VED3,VED7,VEN2,VES,VMT,VPM4,VPM5,VPM7 VPR4,VPR7,VS1,VSD1,VSG,VSW,VS17,VS3,VS4,VTE2,VTX,VTX1 AR,ARC6,BL,DS,DSP,EN,ET,ETX,HG1,HG12,HH,HHQ4,HH26,HX,HXE,HXE2 HXE8,HXQ,HXU,HX2,HX26,HX4,KR,KTA,LAX,LAX2,LD,LDB1,LDB3,LDM,LD4 LH,LHB3,LHQ4,LHW,LJ,LJC7,LJD,LJG,LJS,LMT,LSJ,LSJ4,LSS,LSS1 LSS4,LTA,LTk,LVL,LW2,LX,LXU,LX2,LX26,LX4,NJ,NJG,NSJ,NW,PH,PHM PHU,PM,PM2,PX,PXU,PX2,QA,QAB1,QAB3,QAX,QAX2,QA2,QA26,QBC2,QBT2 QBT6,QBU2,QCB2,QCL,QD,QE,QFE4,QGR2,QGR9,QH,QHE,QHP1,QHQ4,QH26 QI2,QKA4,QM,QMC6,QMC8,QMD6,QME4,QMH,QMX2,QMZ2,QNT,QNT2,QNT4 QNZ,QP,QPU,QSC2,QSC9,QS2,QT,QVL,QWA4,QWM2,QWX2,QWX3,QX,QXB QXB1,QXC,QXC6,QXC9,QXE,QXE2,QXE4,QXE6,QXE8,QXF,QXF2,QXM1,QXQ QXS,QXS2,QXU,QXW,QXW2,QX2,QX22,QX26,QX4,QX7,RAC,RD,RD4,REX4 RFR,RFR2,RH,RHA,RHA2,RHQ4,RH2,RH26,RMB4,RMD,RMG2,RNG,RSK,RSS1 RTB2,RX,RXE,RXE2,RXE4,RXU,RX4,SAC,SAD2,SCJ,SD,SDB1,SDB3,SDN SDS,SDS2,SDS3,SD16,SD4,SE,SEE,SG24,SH,SHM,SHQ4,SHRY,SHR4,SJ SJC,SJC1,SJC5,SJG,SKM,SMB4,SMC7,SMC9,SMJ,SMJ1,SMW2,SMX4,SM11 SM12,SM14,SNX,SNX1,SSK1,SSK2,SSX2,ST,STA,STM,STP,STQ,SWG4,SWX SWX2,SWX4,SW2,SX,AXB,SXE,SXE4,SXS4,SXU,SX4,SX7,S1CY,TCS2,TH THU,TX,TCX9,TXU,TX2,TX26,TX4,UH,UX,UXU,VA,VA2,VEBM,VEB2,VED VED1,VED5,VED6,VGE4,VG24,VH,VHA7,VHH4,VHQ4,VMB3,VMS4,VMS7,VS VSD,VSD7,VSX,VSX1,VSX3,VS1,VTD,VTD1,VTU1,VVA,VWA2,VW12,VX,VXD VXD1,VXE,VXE4,VXE6,VXE7,VXG,VXM,VXU,VXU1,VXW1,VXW2,VX2 VX26,VX4,WDA6,WJP,WKD6,WKT2,WKT4,WKT6,WMB0,WME2,WME4,WMT
			-	2	2	2		



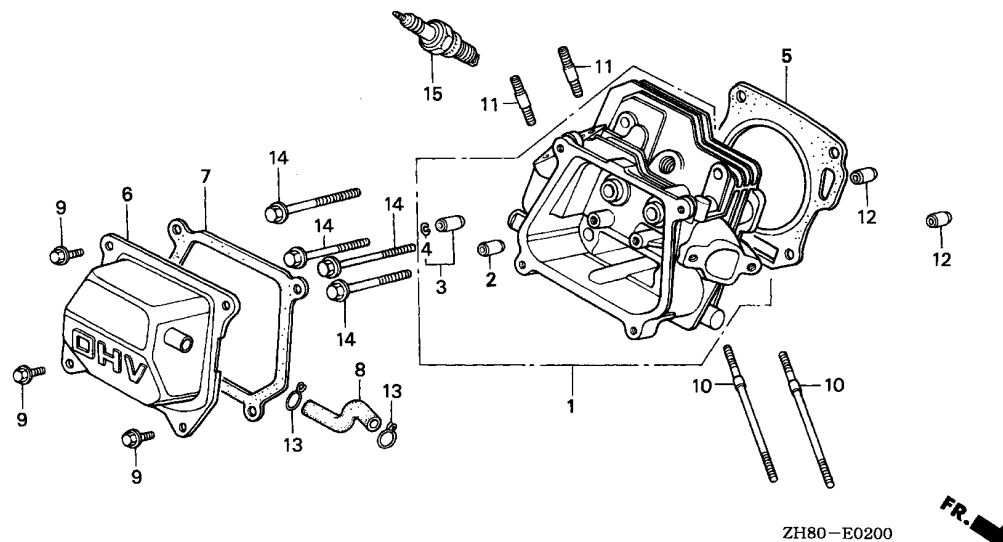

2

Ref. No.	Part No.	Description	Reqd. QTY				Serial No.	Parts catalogue code
			(1)	(2)	(3)	(4)		
			GX160K1					
11	90047-ZE1-000	BOLT, STUD, 8X32	2	2	2	2		
12	94301-10160	DOWEL PIN, 10X16	2	2	2	2		
13	95002-80000	CLIP, TUBE (C12)	2	-	-	-	-----	HXQ,LSS4,QSC2,QSC9,QXC,QXC9,QXQ,TXC9
			-	(2)	-	-		
14	95723-08060-00	BOLT, FLANGE, 8X60	4	4	4	4		
15	98079-54841	PLUG, SPARK (BP4ES)(NGK)	1	-	-	-	-----	5249928 AR
			1	-	-	-	4814968	6276049 KR
	98079-54846	PLUG, SPARK (BPR4ES)(NGK) ...	1	-	-	-	-----	ARC6
			1	-	-	-	5249929	----- AR
			1	-	-	-	6276050	----- KR
	98079-54854	PLUG, SPARK (W14EP-U)(DENSO)	1	-	-	-	-----	5249928 AR
			1	-	-	-	4814968	6276049 KR
	98079-54855	PLUG, SPARK (W14EPR-U)(DENSO)	1	-	-	-	-----	ARC6
			1	-	-	-	5249929	----- AR
			1	-	-	-	6276050	----- KR
	98079-55841	PLUG, SPARK (BP5ES)(NGK)	(1)	-	-	-	-----	VS1
			(1)	-	-	-	-----	4814967 KR
			(1)	-	-	-	-----	6276049 VS
			-	(1)	-	-		

Ref. No.	Part No.	Description	Reqd. QTY				Serial No.	Parts catalogue code
			GX160K1					
			(1)	(2)	(3)	(4)		
15)	98079-55846	PLUG, SPARK (BPR5ES)(NGK) ...	1	-	-	-	6276050 ----- VS	
			(1)	-	(1)	-	----- VS	
							BL, HG1, HG12, HX, HXE, HXE2, HXE8, HXQ, HXU, HX2, HX26, HX4, LAX, LAX2, LD4, LH, LHB3, LHQ4, LHW, LSJ4, LSS4, LVL, LX, LXU, LX2, LX26, LX4, QA, QAB1, QAB3, QAX, QAX2, QA2, QA26, QBC2, QBT2, QBT6, QBU2, QCB2, QCL, QGR2, QGR9, QH, QHQ4, QH26, QI2, QMC6, QME4, QMH, QMX2, QMZ2, QNT, QNT2, QNT4, QP, QPU, QS2, QVL, QWA4, QWM2, QWX2, QWX3, QX, QXB, QXB1, QXF, QXF2, QXM1, QXQ, QXU, QX2, QX22, QX26, QX4, QX7, RD4, REX4, RFR, RFR2, RH, RHA, RHA2, RHQ4, RH2, RH26, RMG2, RSK, RTB2, RX, RXE, RXE4, RXU, RX4, SAD2, SDS, SD4, SG24, SH, SHM, SHQ4, SM12, STM, SWX2, SWX4, TCS2, TX, TXU, TX2, TX26, TX4, UX, UXU, VED, VED1, VED5, VED6, VGE4, VH, VHA7, VHH4, VHQ4, VIH1, VMS4, VMS7, VPM4, VPM5, VPM7, VPR4, VPR7, VSD, VSD1, VSD7, VSX, VSX1, VSX3, VS17, VTD, VTD1, VTU1, VWA, VWA2, VW12, VX, VXG, VXM, VXU, VXU1, VXX, VXX1, VXX2, VX2, VX26, VX4, WDA6, WKD6, WKT2, WKT4, WKT6, WMBO, WME2, WME4, WMT	
	98079-55854	PLUG, SPARK (W16EP-U)(DENSO)	-	(1)	-	(1)	----- VS1	
			(1)	-	-	-	4814967 KR	
			(1)	-	-	-	6276049 VS	
	98079-55855	PLUG, SPARK (W16EPR-U)(DENSO)	1	-	-	-	6276050 ----- VS	
			(1)	-	(1)	-	----- VS	
							BL, HG1, HG12, HX, HXE, HXE2, HXE8, HXQ, HXU, HX2, HX26, HX4, LAX, LAX2, LH, LHB3, LHQ4, LHW, LSJ4, LSS4, LVL, LX, LXU, LX2, LX26, LX4, QA, QAB1, QAB3, QAX, QAX2, QA2, QA26, QBC2, QBT2, QBT6, QBU2, QCB2, QCL, QGR2, QGR9, QH, QHP1, QHQ4, QH26, QI2, QME4, QMH, QMX2, QMZ2, QNT, QNT2, QNT4, QP, QPU, QS2, QVL, QWA4, QWM2, QWX2, QWX3, QX, QXB, QXB1, QXF, QXF2, QXM1, QXQ, QXU, QX2, QX22, QX26, QX4, QX7, REX4, RFR, RFR2, RH, RHA, RHA2, RHQ4, RH2, RH26, RMG2, RSK, RTB2, RX, RXE, RXE4, RXU, RX4, SAD2, SG24, SH, SHM, SHQ4, SM12, STM, SWX2, SWX4, TCS2, TX, TXU, TX2, TX26, TX4, UX, UXU, VED, VED1, VED5, VED6, VGE4, VH, VHA7, VHH4, VHQ4, VIH1, VMS4, VMS7, VPM4, VPM5, VPM7, VPR4, VPR7, VSD, VSD1, VSD7, VSX, VSX1, VSX3, VS17, VTD, VTD1, VTU1, VWA, VWA2, VW12, VX, VXG, VXM, VXU, VXU1, VXX, VXX1, VXX2, VX2, VX26, VX4, WDA6, WKD6, WKT2, WKT4, WKT6, WME2, WME4, WMT	
			(1)	-	-	-	3923402 ----- LD4, QMC6, RD4, SDS, SD4, WMBO	
	98079-56841	PLUG, SPARK (BP6ES)(NGK)	1	-	1	-	----- VS	
			(1)	-	(1)	-	----- VS	
							BL, EN, ET, ETX, LJJD, LJS, LMT, LSS1, LTA, LTK, LVL, LW2, NJC1, PM, QIH1, QM, QVL, RMD, SDN, SDS3, SKM, SMJ, SM11, ST, STA, STM, SW2, VS1, WIH1, VSX, VSX1, VS3, VS4	
			1	-	-	-	4224869 ----- VSX, VSX1, VS3, VS4	
			1	-	-	-	3923401 ----- LD4, QMC6, RD4, SDS, SD4, WMBO	
			1	-	-	-	4814967 KR	
			1	-	-	-	6276049 DS, DSP, LD, LDB1, LDB3, LDM, LHB3, LJ, LJC7, LJG, LSJ, LSS, NJ, NJG, NSJ, NW, PM2, QAB1, QAB3, QD, RD, RNG, RSS1, SCJ, SD, SDB1, SDB3, SDS2, SEE, SJ, SJC, SJC1, SJC5, SJG, SMJ1, SSK1, VED, VS, VSB1, VSX3, VTD, VTD1, VTX, VTX1, VXD, VXD1, WJP	
			-	(1)	-	-	----- UIH	
			-	-	(1)	-	----- UIH	



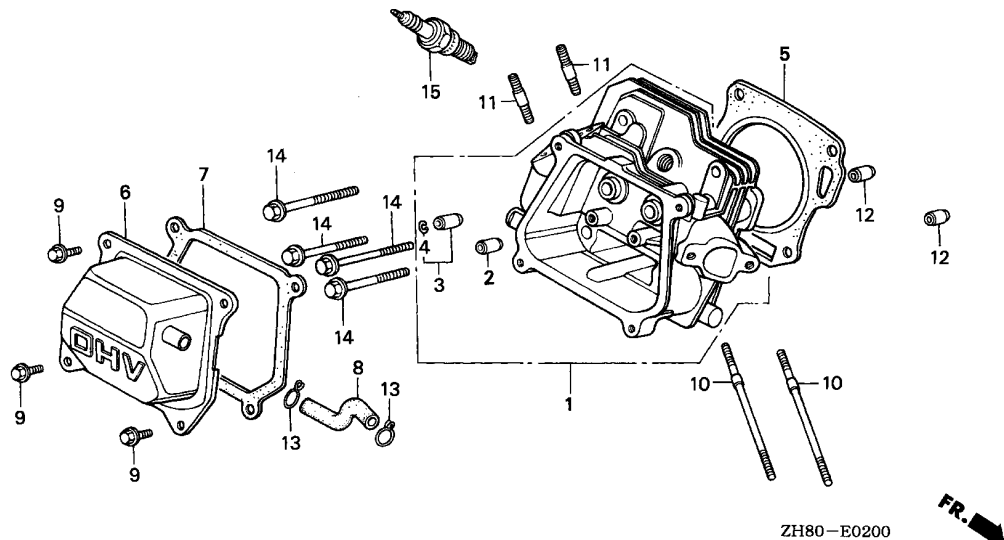

2

Ref. No.	Part No.	Description	Reqd. QTY				Serial No.	Parts catalogue code
			(1)	(2)	(3)	(4)		
15)	98079-56846	PLUG, SPARK (BPR6ES) (NGK) ...	1	-	1	-	-----	EMA,EMA2,HG1,HG12,HH,HHQ4,HH26,HX,HXE,HXE2,HXE8,HXQ,HXU,HX2 HX26,HX4,KTA,LAX,LAX2,LH,LHQ4,LHW,LSJ4,LSS4,LX,LXU,LX2,LX26 LX4,NJC1,PH,PHM,PHU,PX,PXU,PX2,QA,QAX,QAX2,QA2,QA26,QBC2,QBT2 QBT6,QBU2,QCB2,QCL,QE,QFE4,QGR2,QGR9,QH,QHE,QHQ4,QH26,QI2,QKA4 QMC8,QMD6,QME4,QMH,QMX2,QMZ2,QNT,QNT2,QNT4,QNZ,QP,QPU,QSC2 QSC9,QS2,QWA4,QWM2,QWX2,QWX3,QX,QXB,QXB1,QXC,QXC6,QXC9,QXE QXE2,QXE4,QXE6,QXE8,QXF,QXF2,QXM1,QXQ,QXS,QXS2,QXU,QXW,QXW2 QX2,QX22,QX26,QX4,QX7,RAC,REX4,RFR,RFR2,RH,RHA,RHA2,RHQ4,RH2 RH26,RMB4,RMG2,RSK,RTB2,RX,RXE,RXE2,RXE4,RXU,RX4,SAC,SAD2,SD16 SE,SG24,SH,SHM,SHQ4,SHRY,SHR4,SMB4,SMC7,SMC9,SMW2,SMX4,SM12 SM14,SNX,SNX1,SSK2,SSX2,STM,STP,STQ,SWG4,SWX,SWX2,SWX4,SX, SXB SXE,SXE4,SXS4,SXU,SX4,SX7,S1CY,TCS2,TH,THU,TX, TXC9, TXU, TX2 TX26, TX4, UH, UX, UXU, VA, VA2, VEBM, VEB2, VED1, VED2, VED3, VED5, VED6 VED7, VEN2, VES, VGE4, VG24, VH, VHA7, VHH4, VHQ4, VIH1, VMB3, VMS4, VMS7 VMT, VPM4, VPM5, VPM7, VPR4, VPR7, VSD, VSD1, VSD7, VSG, VSW, VS17, VTE2 VTU1, VWA, VWA2, VW12, VX, VXE, VXE4, VXE6, VXE7, VVG, VXM, VXU, VXU1, VXW VXW1, VXW2, VX2, VX26, VX4, WDA6, WKD6, WKT2, WKT4, WKT6, WME2, WME4, WMT LD4, QMC6, RD4, SDS, SD4, WMBO DS, DSP, LD, LDB1, LDB3, LDM, LHB3, LJ, LJC7, LJG, LSJ, LSS, NJ, NJG, NSJ, NW PM2, QAB1, QAB3, QD, RD, RNG, RSS1, SCJ, SD, SDB1, SDB3, SDS2, SEE, SJ, SJC SJC1, SJC5, SJG, SMJ1, SSK1, VED, VS, VSB1, VSX3, VTD, VTD1, VTX, VTX1, VXD VXD1, WJP 1 - - - 3923402 ----- 1 - - - 6276050 ----- 1 - - - 4224868 VSX, VSX1, VS3, VS4 - (1) - 1

Ref. No.	Part No.	Description	Reqd. QTY				Serial No.	Parts catalogue code	
			(1)	(2)	(3)	(4)			
15)	98079-56854	PLUG, SPARK (W20EP-U) (DENSO)	1	-	(1)	-	-----	BL,EN,ET,ETX,LJJD,LJS,LMT,LSS1,LTA,LTK,LVL,LW2,PM,QM,QT,QVL,QZ	
							-----	RMD,SDN,SDS3,SKM,SMJ,SM11,ST,STA,STM,SW2,UIH,VS1,WIH1	
			1	-	-	-	4224869	-----	VSX,VSX1
			1	-	-	-	3923401	-----	LD4,RD4,SDS,SD4,WMB0
			1	-	-	-	4814967	-----	KR
			1	-	-	-	6276049	-----	DS,DSP,LD,LDB1,LDB3,LDM,LHB3,LJ,LJC7,LJG,LSJ,LSS,NJ,NJG,NSJ,NW
									PM2,QAB3,QD,RD,RNG,RSS1,SCJ,SD,SDB1,SDB3,SDS2,SEE,SJ,SJC,SJC1
									SJC5,SJG,SMJ1,SSK1,VED,VS,VS1,VSX3,VTD,VTD1,VTX,VTX1,VXD,VXD1
			1	-	-	-	3923402	-----	6276049 QAB1
			1	-	-	-	4224869	-----	6276049 VS3,VS4
	98079-56855	PLUG, SPARK (W20EPR-U) (DENSO)	1	-	(1)	-	-----	EMA,EMA2,HG1,HG12,HH,HHQ4,HH26,HX,HXE,HXE2,HXE8,HXQ,HXU,HX2	
								HX26,HX4,KTA,LAX,LAX2,LH,LHQ4,LHW,LSJ4,LSS4,LX,LXU,LX2,LX26	
								LX4,NJC1,PH,PHM,PHU,PX,PXU,PX2,QA,QAX,QAX2,QA2,QA26,QBC2,QBT2	
								QBT6,QBU2,QCB2,QCL,QE,QFE4,QGR2,QGR9,QH,QHP1,QHQ4,QH26,QI2	
								QKA4,QME4,QMH,QMX2,QMZ2,QNT,QNT2,QNT4,QP,QPU,QSC2,QSC9,QS2	
								QWA4,QWM2,QWX2,QWX3,QX,QXB,QXB1,QXC,QXC6,QXC9,QXE,QXE2,QXE4	
								QXE6,QXE8,QXF,QXF2,QXM1,QXQ,QXS,QXS2,QXU,QXW,QXW2,QX2,QX22	
								QX26,QX4,QX7,RAC,REX4,RFR,RFR2,RH,RHA,RHA2,RHQ4,RH2,RH26,RMG2	
								RSK,RTB2,RX,RXE,RXE2,RXE4,RXU,RX4,SAC,SAD2,SD16,SE,SG24,SH,SHM	
								SHQ4,SHRY,SHR4,SMW2,SMX4,SM12,SM14,SNX,SNX1,SSK2,SSX2,STM,STP	
						STQ,SWG4,SWX,SWX2,SWX4,SX,SXB,SXE,SXE4,SXS4,SXU,SX4,SX7,S1CY			
						TCS2,TH,THU,TX,TC9,TXU,TX2,TX26,TX4,UH,UX,UXU,VA,VA2,VEBM			
						VEB2,VED1,VED2,VED3,VED5,VED6,VED7,VEN2,VES,VGE4,VG24,VH,VHA7			
						VHH4,VHQ4,VIH1,VMS4,VMS7,VMT,VPM4,VPM5,VPM7,VPR4,VPR7,VSD,VSD1			
						VSD7,VSG,VSU,VS17,VTE2,VTU1,VVA,VVA2,VW12,VX,VXE,VXE4,VXE6			
						VXE7,VXG,VXM,VXU,VXU1,VXW,VXW1,VXW2,VX2,VX26,VX4,WDA6,WKD6			
						WKT2,WKT4,WKT6,WME2,WMT			
						LD4,QMC6,RD4,SDS,SD4,WMB0			
						DS,DSP,LD,LDB1,LDB3,LDM,LHB3,LJ,LJC7,LJG,LSJ,LSS,NJ,NJG,NSJ,NW			
						PM2,QAB1,QAB3,QD,RD,RNG,RSS1,SCJ,SD,SDB1,SDB3,SDS2,SEE,SJ,SJC			
						SJC1,SJC5,SJG,SMJ1,SSK1,VED,VS,VS1,VSX3,VS3,VS4,VTD,VTD1,VTX			
						VTX1,VXD,VXD1			
						-----	4224868 VSX,VSX1		



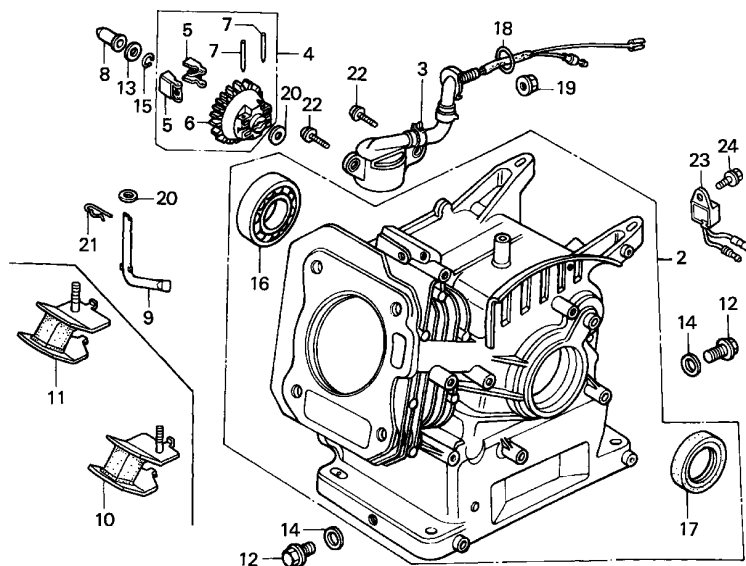

ZH80-E0300



Ref. No.	L.O.N.	(Relative ref. Number) Description	F.R.T.
2	1101A0	BARREL, CYLINDER	2.0
3		(18)	
	6151E8	SWITCH, OIL LEVEL	0.5
	61161A7	HOLDER, GOVERNOR WEIGHT	1.0
	61161B6	SLIDER, GOVERNOR	0.4
	61161B4	SHAFT, GOVERNOR ARM	0.9
	61101A4	BEARING, CRANKSHAFT :FRONT ...	1.9
	61101E4	OIL SEAL, CRANKSHAFT :FRONT ..	1.8
	6151A0	ALERT UNIT, OIL	0.1

Ref. No.	Part No.	Description	Reqd. QTY				Serial No.	Parts catalogue code
			(1)	(2)	(3)	(4)		
2	12000-ZF1-020	BARREL ASSY., CYLINDER (STD.)	GX160K1				4067884 DS,DSP,LJ,LJD,LJG,LJS,LMT,LSS,LSS1,LTK,L1,Q1,R1,SCJ,SJ,SJC,SJG SSK1,ST,STA,STM,STP,STQ,S1,T1,V1,WJP,W1	
			1	(1)	-	-		
			1	-	-	-		
			1	-	-	-		
12000-ZF1-812	BARREL ASSY., CYLINDER (OIL ALERT)	1	(1)	-	-	4067884 QA,QA2,QM22,RFR,RFR2,RH,RHA,RHA2,RH2,RMD,RMG2,RNG,RTB2,SSK2 H1,U1		
		1	-	-	-	4067884 EMA,EMA2,ETX,HG1,HG12,HX,HXE,HXQ,HX2,HX26,HX4,LAX,LAX2,LX,LX2 LX26,LX4,PX,PX2,QA,QAX,QAX2,QBT2,QBT6,QBU2,QGR2,QKA4,QMC8,QMD6 QMX2,QNT,QNT2,QSC2,QX,QXB,QXB1,QXC,QXC6,QXC9,QXE,QXE2,QXE4 QXE6,QXF,QXF2,QXQ,QXS,QXS2,QXW,QXW2,QX2,QX26,QX4,RX,RXE,RXE4 RX4,SAD2,SKM,SMC7,SMC9,SMJ,SMJ1,SMW2,SNX,SWG4,SWX,SX,SXB,SXE SXE4,SX4,TX,TXC9,TX2,TX26,TX4,UX,VA2,VEBM,VEB2,VED1,VED2,VED3 VED5,VGE4,VHH4,VMB3,VMS4,VSD,VSD1,VSX,VSX1,VS3,VS4,VWA,VWA2 VW12,VX,VXE,VXE4,VXG,VXU,VXW,VXW1,VXW2,VX2,VX26,VX4,WKT2,WMT		
12000-ZH8-000	BARREL ASSY., CYLINDER	1	(1)	-	-	4067884 VA		
		1	(1)	-	-	4193707 EN,ET,HH,HHQ4,HH26,KTA,LD,LDB1,LDB3,LD4,LH,LHB3,LHQ4,LTA,LW2 L1,PH,PHU,PM,PM2,QAB1,QAB3,QA26,QD,QE,QH,QHE,QHQ4,QH26,QM,QMC6 QME4,QNZ,QP,QPU,QT,Q1,R1,SAC,SD,SDB1,SDB3,SDS,SDS2,SDS3,SD16 SD4,SE,SEE,SH,SHQ4,SMB4,STA,SW2,S1,TH,THU,T1,UH,VED,VH,VHQ4,VS VS1,V1,WMB0,W1		
12000-ZH8-405	1	-	-	-	4078965 QA,RAC,RD,RD4,RHQ4,RH26,RMB4,RSK		
		1	(1)	-	-	4067885 DS,DSP,H1,LJD,LMT,LSS,LSS1,LTK,SJC,STP,U1		
		1	(1)	-	-	4193708 EN,ET,LDB1,LDB3,LD4,LTA,PH,PHU,PM,PM2,QAB1,QM,RAC,RFR2,RNG,SAC SDB1,SDB3,SDS2,SDS3,SEE,SMB4,STA,SW2,TH,THU,T1,UH,VH,VHQ4,VS VS1,V1		
		1	-	1	-	LDM,LHW,LSJ,LSS4,NW,QIH1,REX4,SDN,SHR4,VTE2		
1	-	-	-	4078966 QA,RFR,RHA,SSK2				

Ref. No.	Part No.	Description	Reqd. QTY				Serial No.	Parts catalogue code
			GX160K1					
			(1)	(2)	(3)	(4)		
(2)	12000-ZH8-406	BARREL ASSY., CYLINDER (OIL ALERT)	1	(1)	-	-	4067885	----- EMA,ETX,HG1,HXE,HXQ,H1,LAX,LAX2,PX2,QAX,QBT2,QBU2,QNT2,QSC2,QXB,QXB1,QXF,QXQ,QXS,QXW2,SAD2,SWX,AXB,T1,UX,U1,VA,VEB2,VMB3,VWA,VXE,VXG,VXW,VXW1,VX26,V1
			1	-	1	1	-----	----- QWM2,QWX3,STM,VED7,VIH1,VSDP,VSW,VTD,VTD1,VTX,VTX1,VXE6,VXP
	12000-ZH8-407	BARREL ASSY., CYLINDER	-	-	1	-	-----	----- UIH,WIH1
	12000-ZH8-690	1	-	-	-	4078965	4078965 NJ,NJG
	12000-ZH8-691	1	-	-	-	4078966	4078966 RFR,RH,RHA
			1	-	-	-	4078966	4193707 NJ,NJG,RAC,RD,RD4,RFR2,RHA2,RHQ4,RH2,RH26,RMB4,RMD,RMG2,RNG,RSK,RTB2
	12000-ZH8-901	1	-	-	-	-----	----- QZ
	12000-ZH8-415	1	(1)	-	-	4193708	8565637 HH,HHQ4,HH26,KTA,LD,LH,LHB3,LHQ4,LW2,L1,NJ,NJG,QAB3,QA26,QD,QE,QH,QHE,QHQ4,QH26,QMC6,QME4,QNZ,QP,QPU,QT,Q1,RD,RD4,RHA2,RHQ4,RH2,RH26,RMB4,RMD,RMG2,RSK,RTB2,R1,SD,SDS,SD16,SD4,SE,SH,SHQ4,S1,VED,WMB0,W1
			1	-	-	-	8531480	QBC2
			1	-	-	-	8565637	AR,ARC6,BL,KR,LSJ4,LVL,NJC1,NSJ,PHM,QCB2,QFE4,QHP1,QVL,RSS1,SHM,SHRY,SM11,S1CY,WDA6,WME4
			1	-	-	-	4067885	8565637 LJ,LJG,LJS,SCJ,SJ,SJG,SSK1,ST,STM,STQ,WJP
			1	-	-	-	4078966	8565637 QA2,QMZ2,RH
	12000-ZH8-416	BARREL ASSY., CYLINDER (OIL ALERT)	1	(1)	-	-	4067885	8565637 EMA2,HG12,HX,HX2,HX26,HX4,LX,LX2,LX26,LX4,L1,PX,QAX2,QBT6,QGR2,QKA4,QMC8,QMD6,QMX2,QNT,QX,QXC,QXC6,QXC9,QXE,QXE2,QXE4,QXE6,QXF2,QXS2,QXW,QX2,QX26,QX4,Q1,RX,RXE,RXE4,RX4,R1,SKM,SMC7,SMC9,SMJ,SMJ1,SMW2,SNX,SWG4,SX,SXE,SXE4,SX4,S1,TX,TXC9,TX2,TX26,TX4,VA2,VEBM,VED1,VED2,VED3,VED5,VGE4,VHH4,VMS4,VSD,VSD1,VSX,VSX1,VS3,VS4,VWA2,VW12,VX,VXE4,VXU,VXW2,VX2,VX4,WKT2,WMT,W1
			1	-	-	-	8527259	VEN2,VSG
			1	-	-	-	8565637	HXE2,HXE8,HXU,LJC7,LXU,PXU,QCL,QGR9,QI2,QMH,QNT4,QSC9,QS2,QWA4,QWX2,QXE8,QXM1,QXU,QX22,QX7,RXE2,RXU,SG24,SJC1,SJC5,SMX4,SM12,SM14,SNX1,SSX2,SWX2,SWX4,SXS4,SXU,SX7,TCS2,TXU,UXU,VED6,VG24,VMS7,VMT,VPM4,VPM7,VPR4,VPR7,VSU1,VSD7,VSX3,VS17,VTU1,VXD,VXD1,VXE7,VXM,VXU1,WKD6,WKT4,WKT6,WME2
			-	-	-	1	2000281	SXP1
	12000-ZH8-425	BARREL ASSY., CYLINDER	1	(1)	-	-	8565638	----- AR,ARC6,BL,HH,HHQ4,HH26,KR,KTA,LD,LH,LHB3,LHQ4,LJ,LJG,LJS,LSJ4,LVL,LW2,L1,NJ,NJC1,NJG,NSJ,PHM,QAB3,QA2,QA26,QCB2,QD,QE,QFE4,QH,QHE,QHP1,QHQ4,QH26,QMC6,QME4,QMZ2,QNZ,QP,QPU,QT,QVL,Q1,RD,RD4,RH,RHA2,RHQ4,RH2,RH26,RMB4,RMD,RMG2,RSK,RSS1,RTB2,R1,SCJ,SD,SDS,SD16,SD4,SE,SH,SHM,SHQ4,SHRY,SJ,SJG,SM11,SSK1,ST,STM,STQ,S1,S1CY,VED,WDA6,WJP,WMB0,WME4,W1
			1	-	-	-	8531481	----- QBC2
	12000-ZH8-426	BARREL ASSY., CYLINDER (OIL ALERT)	1	(1)	-	-	8565638	----- EMA2,HG12,HX,HXE2,HXE8,HXU,HX2,HX26,HX4,LJC7,LX,LXU,LX2,LX26,LX4,L1,PX,PXU,QAX2,QBT6,QCL,QGR2,QGR9,QI2,QKA4,QMC8,QMD6,QMH,QMX2,QNT,QNT4,QSC9,QS2,QWA4,QWX2,QX,QXC,QXC6,QXC9,QXE,QXE2,QXE4,QXE6,QXE8,QXF2,QXM1,QXS2,QXU,QXW,QX2,QX22,QX26,QX4,QX7,Q1,RX,RXE,RXE2,RXE4,RXU,RX4,R1,SG24,SJC1,SJC5,SKM,SMC7,SMC9,SMJ,SMJ1,SMW2,SMX4,SM12,SM14,SNX,SNX1,SSX2,SWG4,SWX2,SWX4,SX,SXE,SXE4,SXS4,SXU,SX4,SX7,S1,TCS2,TX,TXC9,TXU,TX2,TX26,TX4,UXU,VA2,VEBM,VED1,VED2,VED3,VED5,VED6,VGE4,VG24,VHH4,VMS4,VMS7,VMT,VPM4,VPM7,VPR4,VPR7,VSU1,VSD,VSD1,VSD7,VSX,VSX1,VSX3,VS17,VS3,VS4,VTU1,VWA2,VW12,VX,VXD,VXD1,VXE4,VXE7,VXM,VXU1,VXW2,VX2,VX4,WKD6,WKT2,WKT4,WKT6,WME2,WMT,W1
			1	-	-	-	8527260	----- VEN2,VSG
			1	-	-	-	2000282	----- SXP1



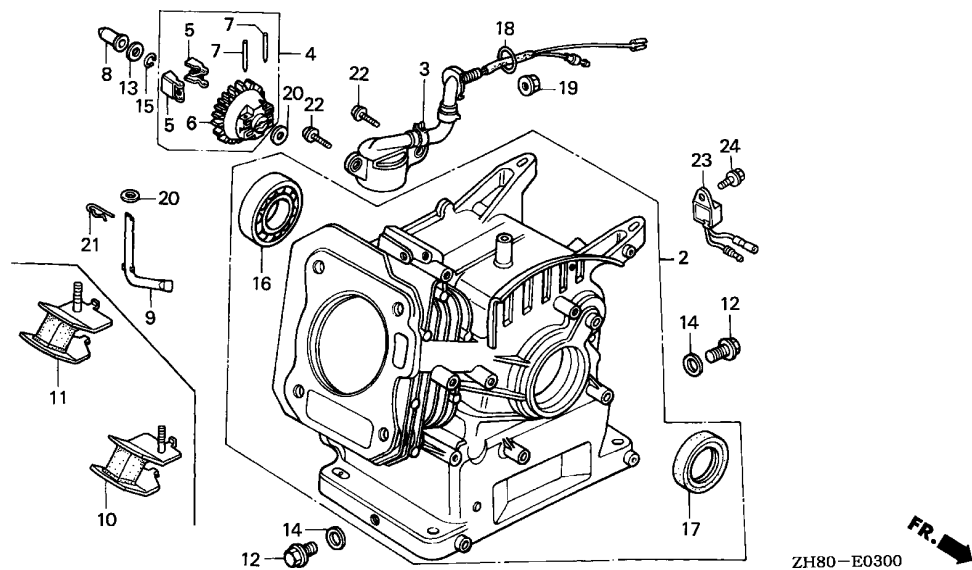

ZH80-E0300

2

Ref. No.	Part No.	Description	Reqd. QTY				Serial No.	Parts catalogue code
			(1)	(2)	(3)	(4)		
3	15510-ZE1-033	SWITCH ASSY., OIL LEVEL	1	-	1	-	-----	EMA,EMA2,ETX,HG1,HG12,HX,HXE,HXE2,HXE8,HXQ,HXU,HX2,HX26,HX4,LAX,LAX2,LJC7,LX,LXU,LX2,LX26,LX4,PX,PXU,PX2,QAX,QAX2,QBT2,QBT6,QBU2,QCL,QGR2,QGR9,QI2,QKA4,QMC8,QMD6,QMH,QMX2,QNT,QNT2,QNT4,QSC2,QSC9,QS2,QWA4,QWM2,QWX2,QWX3,QX,QXB,QXB1,QXC,QXC6,QXC9,QXE,QXE2,QXE4,QXE6,QXE8,QXF,QXF2,QXM1,QXQ,QXS,QXS2,QXU,QXW,QXW2,QX2,QX22,QX26,QX4,QX7,RX,RXE,RXE2,RXE4,RXU,RX4,SAD2,SG24,SJC1,SJC5,SKM,SMC7,SMC9,SMJ,SMJ1,SMW2,SMX4,SM12,SM14,SNX,SNX1,SSX2,STM,SWG4,SWX,SWX2,SWX4,SX,SXB,SXE,SXE4,SXS4,SXU,SX4,SX7,TCS2,TX,TXC9,TXU,TX2,TX26,TX4,UX,UXU,VA,VA2,VEBM,VEB2,VED1,VED2,VED3,VED5,VED6,VED7,VEN2,VES,VGE4,VG24,VHA7,VHH4,VIH1,VMB3,VMS4,VMS7,VMT,VPM4,VPM5,VPM7,VPR4,VPR7,VSU1,VSD,VSD1,VSD7,VSG,VSW,VSX,VSX1,VSX3,VS17,VS3,VS4,VTD,VTD1,VTU1,VTX,VTX1,VWA,VWA2,VW12,VX,VXD,VXD1,VXE,VXE4,VXE6,VXE7,VXG,VXM,VXU,VXU1,VXW,VXW1,VXW2,VX2,VX26,VX4,WKD6,WKT2,WKT4,WKT6,WME2,WMT
4	16510-ZH8-940	GOVERNOR ASSY.	1	-	-	1	-----	WMT

Ref. No.	Part No.	Description	Reqd. QTY				Serial No.	Parts catalogue code
			(1)	(2)	(3)	(4)		
(4)	16510-ZE1-000	GOVERNOR ASSY.	1	-	1	-	AR,ARC6,BL,DS,DSP,EMA,EN,ET,ETX,HG1,HG12,HH,HHQ4,HH26,HX,HXE,HXE2,HXE8,HXQ,HXU,HX2,HX26,HX4,KR,KTA,LAX,LAX2,LD,LDB1,LDB3,LDM,LD4,LH,LHB3,LHQ4,LHW,LJ,LJC7,LJD,LJG,LJS,LMT,LSJ,LSJ4,LSS,LSS1,LSS4,LTA,LTK,LVL,LW2,LX,LXU,LX2,LX26,LX4,NJ,NJC1,NJG,NSJ,NW,PH,PHM,PHU,PM,PM2,PX,PXU,PX2,QA,QAB1,QAB3,QAX,QAX2,QA2,QA26,QBC2,QBT2,QBT6,QBU2,QCB2,QCL,QD,QE,QFE4,QGR2,QGR9,QH,QHE,QHP1,QHQ4,QH26,QIH1,QI2,QKA4,QM,QMC6,QMC8,QMD6,QME4,QMH,QMX2,QMZ2,QNT,QNT2,QNT4,QNZ,QPU,QSC2,QSC9,QS2,QT,QVL,QWA4,QWM2,QWX2,QWX3,QX,QXB,QXB1,QXC,QXC6,QXC9,QXE,QXE2,QXE4,QXE6,QXE8,QXF,QXF2,QXM1,QXQ,QXS,QXS2,QXU,QXW,QXW2,QX2,QX22,QX26,QX4,QX7,RAC,RD,RD4,REX4,RFR,RFR2,RH,RHA,RHA2,RHQ4,RH2,RH26,RMB4,RMD,RMG2,RNG,RSK,RSS1,RTB2,RX,RXE,RXE2,RXE4,RXU,RX4,SAC,SAD2,SCJ,SD,SDB1,SDB3,SDN,SDS,SDS2,SDS3,SD16,SD4,SE,SEE,SG24,SH,SHM,SHQ4,SHRY,SHR4,SJ,SJC,SJC1,SJC5,SJG,SKM,SMB4,SMC7,SMC9,SMJ,SMJ1,SMW2,SMX4,SM11,SM12,SM14,SNX,SNX1,SSK1,SSK2,SSX2,ST,STA,STM,STP,STQ,SWG4,SWX,SWX2,SWX4,SW2,SX,SXB,SXE,SXE4,SXS4,SXU,SX4,SX7,S1CY,TCS2,TH,THU,TX,TC9,TXU,TX2,TX26,TX4,UH,UIH,UX,UXU,VA,VEBM,VEB2,VED6,VEN2,VES,VSB1,VSG,VTE2,VWA,VXG,VXW,VXW1,WDA6,WIH1,WJP,WKD6,WKT2,WKT4,WKT6,WMB0,WME2,WME4	
			1	-	-	-	5048025 VED7	
			1	-	-	-	3943828 QP,VGE4,VMB3,VSD,VSD1,VWA2,VXW2	
			1	-	-	-	4805338 VSW,VXM,VXU	
			1	-	-	-	4913229 EMA2,VA2,VED,VED1,VED2,VED3,VED5,VG24,VH,VHH4,VHQ4,VMS4,VS,VSX,VSX1,VS1,VS3,VS4,VW12,VX,VXD,VXD1,VXE,VXE4,VX2,VX26,VX4	
	16506-ZL0-000	-	1	-	1	VHA7,VIH1,VMS7,VMT,VPM4,VPM5,VPM7,VPR4,VPR7,VSD7,VSG,VSX3,VS17,VTD,VTD1,VTU1,VTX,VTX1,VXE6,VXE7,VXU1	
			1	-	-	-	3943829 QP,VGE4,VMB3,VSD,VSD1,VWA2,VXW2	
			1	-	-	-	4805339 VSW,VXM,VXU	
			1	-	-	-	4913230 EMA2,VA2,VED,VED1,VED2,VED3,VED5,VG24,VH,VHH4,VHQ4,VMS4,VS,VSX,VSX1,VS1,VS3,VS4,VW12,VX,VXD,VXD1,VXE,VXE4,VX2,VX26,VX4	
	5 16511-ZE1-000	WEIGHT, GOVERNOR	1	-	-	-	5048024 VED7	
			2	-	2	-	AR,ARC6,BL,DS,DSP,EMA,EN,ET,ETX,HG1,HG12,HH,HHQ4,HH26,HX,HXE,HXE2,HXE8,HXQ,HXU,HX2,HX26,HX4,KR,KTA,LAX,LAX2,LD,LDB1,LDB3,LDM,LD4,LH,LHB3,LHQ4,LHW,LJ,LJC7,LJD,LJG,LJS,LMT,LSJ,LSJ4,LSS,LSS1,LSS4,LTA,LTK,LVL,LW2,LX,LXU,LX2,LX26,LX4,NJ,NJC1,NJG,NSJ,NW,PH,PHM,PHU,PM,PM2,PX,PXU,PX2,QA,QAB1,QAB3,QAX,QAX2,QA2,QA26,QBC2,QBT2,QBT6,QBU2,QCB2,QCL,QD,QE,QFE4,QGR2,QGR9,QH,QHE,QHP1,QHQ4,QH26,QIH1,QI2,QKA4,QM,QMC6,QMC8,QMD6,QME4,QMH,QMX2,QMZ2,QNT,QNT2,QNT4,QNZ,QPU,QSC2,QSC9,QS2,QT,QVL,QWA4,QWM2,QWX2,QWX3,QX,QXB,QXB1,QXC,QXC6,QXC9,QXE,QXE2,QXE4,QXE6,QXE8,QXF,QXF2,QXM1,QXQ,QXS,QXS2,QXU,QXW,QXW2,QX2,QX22,QX26,QX4,QX7,RAC,RD,RD4,REX4,RFR,RFR2,RH,RHA,RHA2,RHQ4,RH2,RH26,RMB4,RMD,RMG2,RNG,RSK,RSS1,RTB2,RX,RXE,RXE2,RXE4,RXU,RX4,SAC,SAD2,SCJ,SD,SDB1,SDB3,SDN,SDS,SDS2,SDS3,SD16,SD4,SE,SEE,SG24,SH,SHM,SHQ4,SHRY,SHR4,SJ,SJC,SJC1,SJC5,SJG,SKM,SMB4,SMC7,SMC9,SMJ,SMJ1,SMW2,SMX4,SM11,SM12,SM14,SNX,SNX1,SSK1,SSK2,SSX2,ST,STA,STM,STP,STQ,SWG4,SWX,SWX2,SWX4,SW2,SX,SXB,SXE,SXE4,SXS4,SXU,SX4,SX7,S1CY,TCS2,TH,THU,TX,TC9,TXU,TX2,TX26,TX4,UH,UIH,UX,UXU,VA,VEBM,VEB2,VED6,VEN2,VES,VSB1,VSG,VTE2,VWA,VXG,VXW,VXW1,WDA6,WIH1,WJP,WKD6,WKT2,WKT4,WKT6,WMB0,WME2,WME4,WMT	
			2	-	-	-	5048025 VED7	
			2	-	-	-	3943828 QP,VGE4,VMB3,VSD,VSD1,VWA2,VXW2	
			2	-	-	-	4805338 VSW,VXM,VXU	
			2	-	-	-	4913229 EMA2,VA2,VED,VED1,VED2,VED3,VED5,VG24,VH,VHH4,VHQ4,VMS4,VS,VSX,VSX1,VS1,VS3,VS4,VW12,VX,VXD,VXD1,VXE,VXE4,VX2,VX26,VX4	
			-	2	-	2		



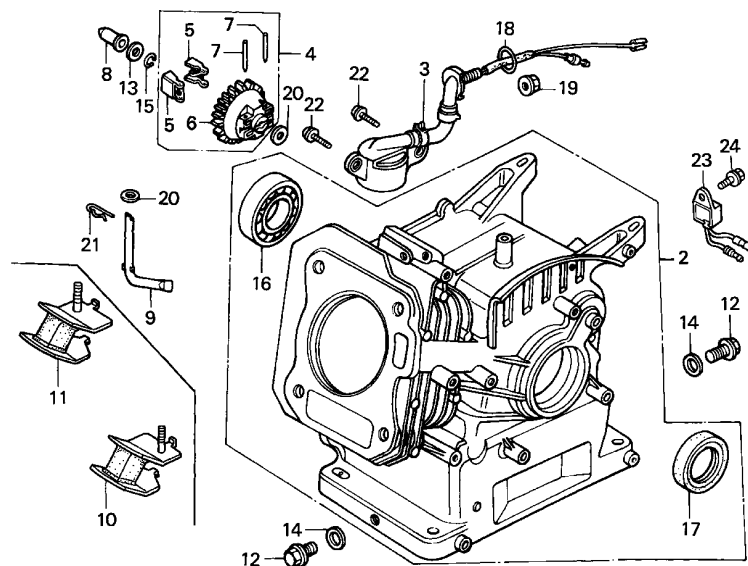

ZH80-E0300



2

Ref. No.	Part No.	Description	Reqd. QTY				Serial No.	Parts catalogue code
			(1)	(2)	(3)	(4)		
6	16512-ZE1-000	HOLDER, GOVERNOR WEIGHT	1	-	1	-	-----	AR,ARC6,BL,DS,DSP,EMA,EN,ET,ETX,HG1,HG12,HH,HHQ4,HH26,HX,HXE,HXE2,HXE8,HXQ,HXU,HX2,HX26,HX4,KR,KTA,LAX,LAX2,LD,LDB1,LDB3,LDM,LD4,LH,LHB3,LHQ4,LHW,LJ,LJC7,LJD,LJG,LJS,LMT,LSJ,LSJ4,LSS,LSS1,LSS4,LTA,LTK,LVL,LW2,LX,LXU,LX2,LX26,LX4,NJ,NJC1,NJG,NSJ,NW,PH,PHM,PHU,PM,PM2,PX,PXU,PX2,QA,QAB1,QAB3,QAX,QAX2,QA2,QA26,QBC2,QBT2,QBT6,QBU2,QCB2,QCL,QD,QE,QFE4,QGR2,QGR9,QH,QHE,QHP1,QHQ4,QH26,QIH1,QI2,QKA4,QM,QMC6,QMC8,QMD6,QME4,QMH,QMX2,QMZ2,QNT,QNT2,QNT4,QNZ,QPU,QSC2,QSC9,QS2,QT,QVL,QWA4,QWM2,QWX2,QWX3,QX,QXB,QXB1,QXC,QXC6,QXC9,QXE,QXE2,QXE4,QXE6,QXE8,QXF,QXF2,QXM1,QXQ,QXS,QXS2,QXU,QXW,QXW2,QX2,QX22,QX26,QX4,QX7,RAC,RD,RD4,REX4,RFR,RFR2,RH,RHA,RHA2,RHQ4,RH2,RH26,RMB4,RMD,RMG2,RNG,RSK,RSS1,RTB2,RX,RXE,RXE2,RXE4,RXU,RX4,SAC,SAD2,SCJ,SD,SDB1,SDB3,SDN,SDS,SDS2,SDS3,SD16,SD4,SE,SEE,SG24,SH,SHM,SHQ4,SHRY,SHR4,SJ,SJC,SJC1,SJC5,SJG,SKM,SMB4,SMC7,SMC9,SMJ,SMJ1,SMW2,SMX4,SM11,SM12,SM14,SNX,SNX1,SSK1,SSK2,SSX2,ST,STA,STM,STP,STQ,SWG4,SWX,SWX2,SWX4,SW2,SX,SXB,SXE,SXE4,SXS4,SXU,SX4,SX7,S1CY,TCS2,TH,THU,TX,TXC9,TXU,TX2,TX26,TX4,UH,UIH,UX,UXU,VA,VEBM,VEB2,VED6,VEN2,VES,VSB1,VSG,VTE2,VVA,VXG,VXW,VXW1,WDA6,WIH1,WJP,WKD6,WKT2,WKT4,WKT6,WMB0,WME2,WME4,WMT
			1	-	-	-	5048025	----- VED7
			1	-	-	-	3943828	QP,VGE4,VMB3,VSD,VSD1,VVA2,VXW2
			1	-	-	-	4805338	VSW,VXM,VXU
			1	-	-	-	4913229	EMA2,VA2,VED,VED1,VED2,VED3,VED5,VG24,VH,VHH4,VHQ4,VMS4,VS,VSX,VSX1,VS1,VS3,VS4,VW12,VX,VXD,VXD1,VXE,VXE4,VX2,VX26,VX4
			-	1	-	1		

Ref. No.	Part No.	Description	Reqd. QTY				Serial No.	Parts catalogue code
			(1)	(2)	(3)	(4)		
7	16513-ZE1-000	PIN, GOVERNOR WEIGHT	2	-	2	-	AR,ARC6,BL,DS,DSP,EMA,EN,ET,ETX,HG1,HG12,HH,HHQ4,HH26,HX,HXE,HXE2,HXE8,HXQ,HXU,HX2,HX26,HX4,KR,KTA,LAX,LAX2,LD,LDB1,LDB3,LDM,LD4,LH,LHB3,LHQ4,LHW,LJ,LJC7,LJD,LJG,LJS,LMT,LSJ,LSJ4,LSS,LSS1,LSS4,LTA,LTk,LVL,LW2,LX,LXU,LX2,LX26,LX4,NJ,NJC1,NJG,NSJ,NW,PH,PHM,PHU,PM,PM2,PX,PXU,PX2,QA,QAB1,QAB3,QAX,QAX2,QA2,QA26,QBC2,QBT2,QBT6,QBU2,QCB2,QCL,QD,QE,QFE4,QGR2,QGR9,QH,QHE,QHP1,QHQ4,QH26,QI2,QKA4,QM,QMC6,QMC8,QMD6,QME4,QMH,QMX2,QM2,QNT,QNT2,QNT4,QNZ,QPU,QSC2,QSC9,QS2,QT,QVL,QWA4,QWM2,QWX2,QWX3,QX,QXB,QXB1,QXC,QXC6,QXC9,QXE,QXE2,QXE4,QXE6,QXE8,QXF,QXF2,QXM1,QXQ,QXS,QXS2,QXU,QXW,QXW2,QX2,QX22,QX26,QX4,QX7,RAC,RD,RD4,REX4,RFR,RFR2,RH,RHA,RHA2,RHQ4,RH2,RH26,RMB4,RMD,RMG2,RNG,RSK,RSS1,RTB2,RX,RXE,RXE2,RXE4,RXU,RX4,SAC,SAD2,SCJ,SD,SDB1,SDB3,SDN,SDS,SDS2,SDS3,SD16,SD4,SE,SEE,SG24,SH,SHM,SHQ4,SHRY,SHR4,SJ,SJC,SJC1,SJC5,SJG,SKM,SMB4,SMC7,SMC9,SMJ,SMJ1,SMW2,SMX4,SM11,SM12,SM14,SNX,SNX1,SSK1,SSK2,SSX2,ST,STA,STM,STP,STQ,SWG4,SWX,SWX2,SWX4,SW2,SX,SXB,SXE,SXE4,SXS4,SXU,SX4,SX7,S1CY,TCS2,TH,THU,TX,TC9,TXU,TX2,TX26,TX4,UH,UIH,UX,UXU,VA,VEBM,VEB2,VED6,VEN2,VES,VSB1,VSG,VTE2,VVA,VXG,VXW,VXW1,WDA6,WI1,WJP,WKD6,WKT2,WKT4,WKT6,WMB0,WME2,WME4,WMT	
			2	-	-	5048025	VED7	
			2	-	-	3943828	QP,VGE4,VMB3,VSD,VSD1,VWA2,VXW2	
			2	-	-	4805338	VSW,VXM,VXU	
			2	-	-	4913229	EMA2,VA2,VED,VED1,VED2,VED3,VED5,VG24,VH,VHH4,VHQ4,VMS4,VS,VSX,VSX1,VS1,VS3,VS4,VW12,VX,VXD,VXD1,VXE,VXE4,VX2,VX26,VX4	
8	16531-ZE1-000	SLIDER, GOVERNOR	-	2	-	2	AR,ARC6,BL,DS,DSP,EMA,EMA2,EN,ET,ETX,HG1,HG12,HH,HHQ4,HH26,HX,HXE,HXE2,HXE8,HXQ,HXU,HX2,HX26,HX4,KR,KTA,LAX,LAX2,LD,LDB1,LDB3,LDM,LD4,LH,LHB3,LHQ4,LHW,LJ,LJC7,LJD,LJG,LJS,LMT,LSJ,LSJ4,LSS,LSS1,LSS4,LTA,LTk,LVL,LW2,LX,LXU,LX2,LX26,LX4,NJ,NJC1,NJG,NSJ,NW,PH,PHM,PHU,PM,PM2,PX,PXU,PX2,QA,QAB1,QAB3,QAX,QAX2,QA2,QA26,QBC2,QBT2,QBT6,QBU2,QCB2,QCL,QD,QE,QFE4,QGR2,QGR9,QH,QHE,QHP1,QHQ4,QH26,QI2,QKA4,QM,QMC6,QMC8,QMD6,QME4,QMH,QMX2,QM2,QNT,QNT2,QNT4,QNZ,QP,QPU,QSC2,QSC9,QS2,QT,QVL,QWA4,QWM2,QWX2,QWX3,QX,QXB,QXB1,QXC,QXC6,QXC9,QXE,QXE2,QXE4,QXE6,QXE8,QXF,QXF2,QXM1,QXQ,QXS,QXS2,QXU,QXW,QXW2,QX2,QX22,QX26,QX4,QX7,RAC,RD,RD4,REX4,RFR,RFR2,RH,RHA,RHA2,RHQ4,RH2,RH26,RMB4,RMD,RMG2,RNG,RSK,RSS1,RTB2,RX,RXE,RXE2,RXE4,RXU,RX4,SAC,SAD2,SCJ,SD,SDB1,SDB3,SDN,SDS,SDS2,SDS3,SD16,SD4,SE,SEE,SG24,SH,SHM,SHQ4,SHRY,SHR4,SJ,SJC,SJC1,SJC5,SJG,SKM,SMB4,SMC7,SMC9,SMJ,SMJ1,SMW2,SMX4,SM11,SM12,SM14,SNX,SNX1,SSK1,SSK2,SSX2,ST,STA,STM,STP,STQ,SWG4,SWX,SWX2,SWX4,SW2,SX,SXB,SXE,SXE4,SXS4,SXU,SX4,SX7,S1CY,TCS2,TH,THU,TX,TC9,TXU,TX2,TX26,TX4,UH,UX,UXU,VA,VEBM,VEB2,VED,VED1,VED2,VED3,VED5,VED6,VED7,VEN2,VES,VGE4,VG24,VH,VHA7,VHH4,VHQ4,VMB3,VMS4,VMS7,VMT,VPM4,VPM5,VPM7,VPR4,VPR7,VS,VSB1,VSD,VSD1,VSD7,VSG,VSW,VSX,VSX1,VSX3,VS1,VS17,VS3,VS4,VTD,VTD1,VTE2,VTU1,VTX,VTX1,VVA,VWA2,VW12,VX,VXD,VXD1,VXE,VXE4,VXE6,VXE7,VXG,VXM,VXU,VXU1,VXW,VXW1,VXW2,VX2,VX26,VX4,WDA6,WJP,WKD6,WKT2,WKT4,WKT6,WMB0,WME2,WME4,WMT	
			-	1	1	1		



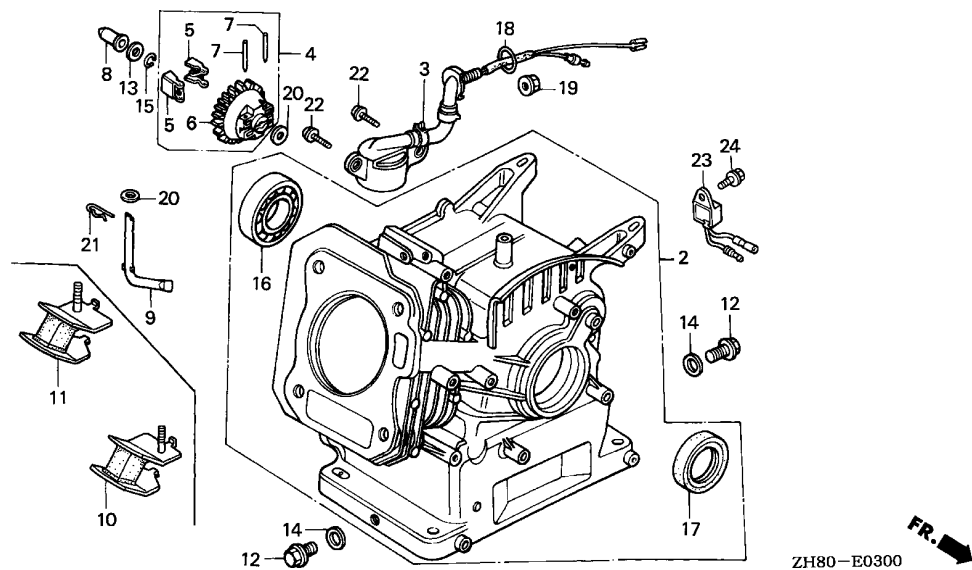

ZH80-E0300

2

Ref. No.	Part No.	Description	Reqd. QTY				Serial No.	Parts catalogue code
			(1)	(2)	(3)	(4)		
9	16541-ZE1-000	SHAFT, GOVERNOR ARM	1	-	-	-	-----	AR, ARC6, BL, DS, DSP, EMA, EMA2, EN, ET, ETX, HG1, HG12, HH, HHQ4, HH26, HX, HXE, HXE2, HXE8, HXQ, HXU, HX2, HX26, HX4, KR, KTA, LAX, LAX2, LD, LDB1, LDB3, LDM, LD4, LH, LHB3, LHQ4, LHW, LJ, LJ2, LJ3, LJ4, LJC7, LJD, LJG, LJS, LMT, LSJ, LSJ4, LSS, LSS1, LSS4, LTA, LTK, LVL, LW2, LX, LXU, LX2, LX26, LX4, NJ, NJC1, NJJ, NSJ, NW, PH, PHM, PHU, PM, PM2, PX, PXU, PX2, QA, QAB1, QAB3, QAX, QAX2, QA2, QA26, QBC2, QBT2, QBT6, QBU2, QCB2, QCL, QD, QE, QFE4, QGR2, QGR9, QH, QHE, QHP1, QHQ4, QH26, QI2, QKA4, QM, QMC6, QMC8, QMD6, QME4, QMH, QMX2, QMZ2, QNT, QNT2, QNT4, QNZ, QP, QPU, QSC2, QSC9, QS2, QT, QVL, QWA4, QWM2, QWX2, QWX3, QX, QXB, QXB1, QXC, QXC6, QXC9, QXE, QXE2, QXE4, QXE6, QXE8, QXF, QXF2, QXM1, QXQ, QXS, QXS2, QXU, QXW, QXW2, QX2, QX22, QX26, QX4, QX7, RAC, RD, RD4, REX4, RFR, RFR2, RH, RHA, RHA2, RHQ4, RH2, RH26, RMB4, RMD, RMG2, RNG, RSK, RSS1, RTB2, RX, RXE, RXE2, RXE4, RXU, RX4, SAC, SAD2, SCJ, SD, SDB1, SDB3, SDN, SDS, SDS2, SDS3, SD16, SD4, SE, SEE, SG24, SH, SHM, SHQ4, SHRY, SHR4, SJ, SJC, SJC1, SJC5, SJG, SKM, SMB4, SMC7, SMC9, SMJ, SMJ1, SMW2, SMX4, SM11, SM12, SM14, SNX, SNX1, SSK1, SSK2, SSS2, ST, STA, STM, STP, STQ, SWG4, SWX, SWX2, SWX4, SW2, SX, SXB, SXE, SXE4, SXS4, SXU, SX4, SX7, S1CY, TCS2, TH, THU, TX, TXC9, TXU, TX2, TX26, TX4, UH, UX, UXU, VA, VA2, VEBM, VEB2, VED, VED1, VED2, VED3, VED5, VED6, VED7, VEN2, VES, VGE4, VG24, VH, VHA7, VHH4, VH4, VHQ4, VMB3, VMS4, VMS7, VMT, VPM4, VPM5, VPM7, VPR4, VPR7, VS, VSB1, VSD, VSD1, VSD7, VSG, VSW, VSX, VSX1, VSX3, VS1, VS17, VS3, VS4, VTD, VTD1, VTE2, VTU1, VTX, VTX1, VWA, VWA2, VW12, VX, VXD, VXD1, VXE, VXE4, VXE6, VXE7, VXG, VXM, VXU, VXU1, VXW, VXW1, VXW2, VX2, VX26, VX4, WDA6, WJP, WKD6, WKT2, WKT4, WKT6, WMB0, WME2, WME4, WMT
10	68326-ZB2-000	RUBBER, FR. BOTTOM	2	1	1	1	-----	VS, VSB1, VSG, VSW, VSX, VSX1, VSX3, VS1, VS3, VS4, VTD, VTD1, VTX, VTX1
11	68327-ZB2-000 68327-898-000	RUBBER, RR. BOTTOM	2	-	-	-	-----	VS, VSB1, VSG, VSW, VSX, VSX1, VSX3, VS1, VS3, VS4, VTD, VTD1, VTX, VTX1, SKM

E-3

CYLINDER BARREL

F16

Ref. No.	Part No.	Description	Reqd. QTY				Serial No.	Parts catalogue code
			(1)	(2)	(3)	(4)		
11)	68328-ZB2-000	RUBBER, BOTTOM	2	-	-	-	NJC1	
12	90131-ZE1-000	BOLT, DRAIN PLUG	2	2	2	2		
13	90451-ZE1-000	WASHER, THRUST, 6MM	1	-	-	-	AR, ARC6, BL, DS, DSP, EMA, EMA2, EN, ET, ETX, HG1, HG12, HH, HHQ4, HH26, HX, HXE, HXE2, HXE8, HXQ, HXU, HX2, HX26, HX4, KR, KTA, LAX, LAX2, LD, LDB1, LDB3, LDM, LD4, LH, LHB3, LHQ4, LHW, LJ, LJ7, LJD, LJG, LJS, LMT, LSJ, LSJ4, LSS, LSS1, LSS4, LTA, LTK, LVL, LW2, LX, LXU, LX2, LX26, LX4, NJ, NJC1, NJG, NSJ, NW, PH, PHM, PHU, PM, PM2, PX, PXU, PX2, QA, QAB1, QAB3, QAX, QAX2, QA2, QA26, QBC2, QBT2, QBT6, QBU2, QCB2, QCL, QD, QE, QFE4, QGR2, QGR9, QH, QHE, QHP1, QHQ4, QH26, QI2, QKA4, QM, QMC6, QMC8, QMD6, QME4, QMH, QMX2, QM2, QNT, QNT2, QNT4, QNZ, QP, QPU, QSC2, QSC9, QS2, QT, QVL, QWA4, QWM2, QWX2, QWX3, QX, QXB, QXB1, QXC, QXC6, QXC9, QXE, QXE2, QXE4, QXE6, QXE8, QXF, QXF2, QXM1, QXQ, QXS, QXS2, QXU, QXW, QXW2, QX2, QX22, QX26, QX4, QX7, RAC, RD, RD4, REX4, RFR, RFR2, RH, RHA, RHA2, RHQ4, RH2, RH26, RMB4, RMD, RMG2, RNG, RSK, RSS1, RTB2, RX, RXE, RXE2, RXE4, RXU, RX4, SAC, SAD2, SCJ, SD, SDB1, SDB3, SDN, SDS, SDS2, SDS3, SD16, SD4, SE, SEE, SG24, SH, SHM, SHQ4, SHRY, SHR4, SJ, SJC, SJC1, SJC5, SJG, SKM, SMB4, SMC7, SMC9, SMJ, SMJ1, SMW2, SMX4, SM11, SM12, SM14, SNX, SNX1, SSK1, SSK2, SSX2, ST, STA, STM, STP, STQ, SWG4, SWX, SWX2, SWX4, SW2, SX, SXB, SXE, SXE4, SXS4, SXU, SX4, SX7, S1CY, TCS2, TH, THU, TX, TXC9, TXU, TX2, TX26, TX4, UH, UX, UXU, VA, VA2, VEBM, VEB2, VED, VED1, VED2, VED3, VED5, VED6, VED7, VEN2, VES, VGE4, VG24, VH, VHA7, VHH4, VHQ4, VMB3, VMS4, VMS7, VMT, VPM4, VPM5, VPM7, VPR4, VPR7, VS, VSB1, VSD, VSD1, VSD7, VSG, VSW, VSX, VSX1, VSX3, VS1, VS17, VS3, VS4, VTD, VTD1, VTE2, VTU1, VTX, VTX1, VWA, VWA2, VW12, VX, VXD, VXD1, VXE, VXE4, VXE6, VXE7, VXG, VXM, VXU, VXU1, VXW, VXW1, VXW2, VX2, VX26, VX4, WDA6, WJP, WKD6, WKT2, WKT4, WKT6, WMBO, WME2, WME4, WMT	
14	90601-ZE1-000	WASHER, DRAIN PLUG, 10.2MM ..	-	1	1	1		
15	90602-ZE1-000	CLIP, GOVERNOR HOLDER	2	2	2	2	AR, ARC6, BL, DS, DSP, EMA, EMA2, EN, ET, ETX, HG1, HG12, HH, HHQ4, HH26, HX, HXE, HXE2, HXE8, HXQ, HXU, HX2, HX26, HX4, KR, KTA, LAX, LAX2, LD, LDB1, LDB3, LDM, LD4, LH, LHB3, LHQ4, LHW, LJ, LJ7, LJD, LJG, LJS, LMT, LSJ, LSJ4, LSS, LSS1, LSS4, LTA, LTK, LVL, LW2, LX, LXU, LX2, LX26, LX4, NJ, NJC1, NJG, NSJ, NW, PH, PHM, PHU, PM, PM2, PX, PXU, PX2, QA, QAB1, QAB3, QAX, QAX2, QA2, QA26, QBC2, QBT2, QBT6, QBU2, QCB2, QCL, QD, QE, QFE4, QGR2, QGR9, QH, QHE, QHP1, QHQ4, QH26, QI2, QKA4, QM, QMC6, QMC8, QMD6, QME4, QMH, QMX2, QM2, QNT, QNT2, QNT4, QNZ, QP, QPU, QSC2, QSC9, QS2, QT, QVL, QWA4, QWM2, QWX2, QWX3, QX, QXB, QXB1, QXC, QXC6, QXC9, QXE, QXE2, QXE4, QXE6, QXE8, QXF, QXF2, QXM1, QXQ, QXS, QXS2, QXU, QXW, QXW2, QX2, QX22, QX26, QX4, QX7, RAC, RD, RD4, REX4, RFR, RFR2, RH, RHA, RHA2, RHQ4, RH2, RH26, RMB4, RMD, RMG2, RNG, RSK, RSS1, RTB2, RX, RXE, RXE2, RXE4, RXU, RX4, SAC, SAD2, SCJ, SD, SDB1, SDB3, SDN, SDS, SDS2, SDS3, SD16, SD4, SE, SEE, SG24, SH, SHM, SHQ4, SHRY, SHR4, SJ, SJC, SJC1, SJC5, SJG, SKM, SMB4, SMC7, SMC9, SMJ, SMJ1, SMW2, SMX4, SM11, SM12, SM14, SNX, SNX1, SSK1, SSK2, SSX2, ST, STA, STM, STP, STQ, SWG4, SWX, SWX2, SWX4, SW2, SX, SXB, SXE, SXE4, SXS4, SXU, SX4, SX7, S1CY, TCS2, TH, THU, TX, TXC9, TXU, TX2, TX26, TX4, UH, UX, UXU, VA, VA2, VEBM, VEB2, VED, VED1, VED2, VED3, VED5, VED6, VED7, VEN2, VES, VGE4, VG24, VH, VHA7, VHH4, VHQ4, VMB3, VMS4, VMS7, VMT, VPM4, VPM5, VPM7, VPR4, VPR7, VS, VSB1, VSD, VSD1, VSD7, VSG, VSW, VSX, VSX1, VSX3, VS1, VS17, VS3, VS4, VTD, VTD1, VTE2, VTU1, VTX, VTX1, VWA, VWA2, VW12, VX, VXD, VXD1, VXE, VXE4, VXE6, VXE7, VXG, VXM, VXU, VXU1, VXW, VXW1, VXW2, VX2, VX26, VX4, WDA6, WJP, WKD6, WKT2, WKT4, WKT6, WMBO, WME2, WME4, WMT	
			-	1	1	1		
16	91001-ZF1-003	BEARING, RADIAL BALL (6205TMB) (NTN)	1	1	-	1	QIH1, VIH1	

2

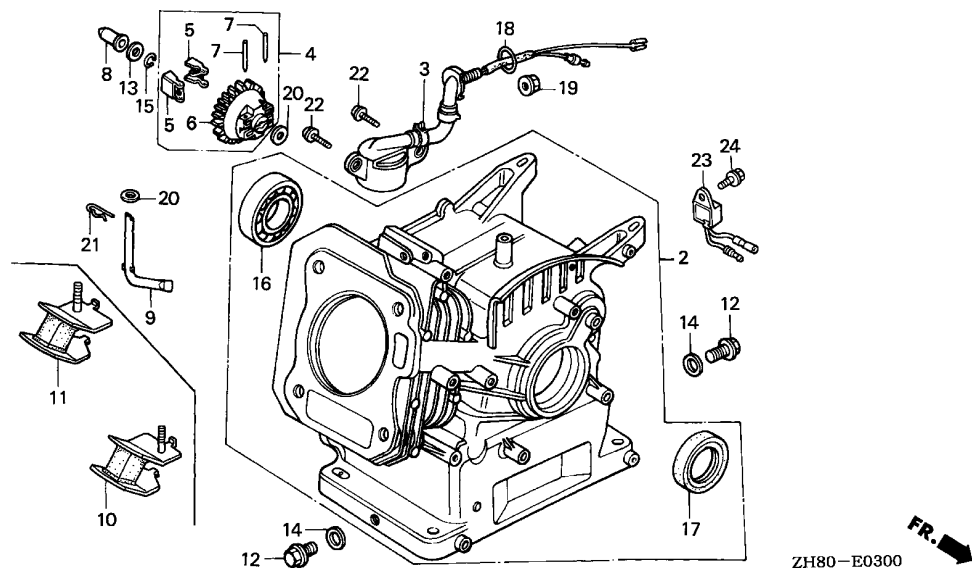

ZH80-E0300



2

Ref. No.	Part No.	Description	Reqd. QTY				Serial No.	Parts catalogue code
			(1)	(2)	(3)	(4)		
			GX160K1					
16)	91001-ZF1-004	BEARING, RADIAL BALL (6205SH) (KOYO)	1	-	1	-	-----	AR, ARC6, BL, DS, DSP, EMA, EMA2, HG1, HG12, HH, HHQ4, HH26, HX, HXE, HXE2, HXE8, HXQ, HXU, HX2, HX26, HX4, KR, KTA, LAX, LAX2, LD, LDB1, LDB3, LDM, LD4, LH, LHB3, LHQ4, LHW, LJ, LJC7, LJD, LJG, LJS, LMT, LSJ, LSJ4, LSS, LSS1, LSS4, LTA, LTK, LVL, LW2, LX, LXU, LX2, LX26, LX4, NJ, NJC1, NJG, NSJ, NW, PH, PHM, PHU, PM, PM2, PX, PXU, PX2, QA, QAB1, QAB3, QAX, QAX2, QA2, QA26, QBC2, QBT2, QBT6, QBU2, QCB2, QCL, QD, QE, QFE4, QGR2, QGR9, QH, QHE, QHP1, QHQ4, QH26, QIH1, QI2, QKA4, QM, QMC6, QMC8, QMD6, QME4, QMH, QMX2, QMZ2, QNT2, QNT4, QNZ, QP, QPU, QSC2, QSC9, QS2, QT, QVL, QWA4, QWM2, QWX2, QWX3, QX, QXB, QXB1, QXC, QXC6, QXC9, QXE, QXE2, QXE4, QXE6, QXE8, QXF, QXF2, QXM1, QXQ, QXS, QXS2, QXU, QXW, QXW2, QX2, QX22, QX26, QX4, QX7, QZ, RAC, RD, RD4, REX4, RFR, RFR2, RH, RHA, RHA2, RHQ4, RH2, RH26, RMB4, RMD, RMG2, RNG, RSK, RSS1, RTB2, RX, RXE, RXE2, RXE4, RXU, RX4, SAC, SAD2, SCJ, SD, SDB1, SDB3, SDN, SDS, SDS2, SDS3, SD16, SD4, SE, SEE, SG24, SH, SHM, SHQ4, SHRY, SHR4, SJ, SJC, SJC1, SJC5, SJG, SKM, SMB4, SMC7, SMC9, SMJ, SMJ1, SMW2, SMX4, SM11, SM12, SM14, SNX, SNX1, SSK1, SSK2, SSK2, ST, STA, STM, STP, STQ, SWG4, SWX, SWX2, SWX4, SW2, SX, SXB, SXE, SXE4, SXS4, SXU, SX4, SX7, S1CY, TCS2, TH, THU, TX, TXC9, TXU, TX2, TX26, TX4, UH, UX, UXU, VA, VA2, VEBM, VEB2, VED, VED1, VED2, VED3, VED5, VED6, VED7, VEN2, VES, VGE4, VG24, VH, VHA7, VHH4, VHQ4, VIH1, VMB3, VMS4, VMS7, VMT, VPM4, VPM5, VPM7, VPR4, VPR7, VS, VSB1, VSD1, VSD7, VSG, VSW, VSX, VSX1, VSX3, VS1, VS17, VS3, VS4, VTD, VTD1, VTE2, VTU1, VTX, VTX1, VWA, VWA2, VW12, VX, VXD, VXD1, VXE, VXE4, VXE6, VXE7, VXG, VXM, VXU, VXU1, VXX, VXX1, VXX2, VX2, VX26, VX4, WDA6, WJP, WKD6, WKT2, WKT4, WKT6, WMBO, WME2, WME4, WMT
	96100-62050-00	BEARING, RADIAL BALL, 6205	1	-	1	-	-----	LVL, QVL, SJC1, STM, UIH, WIH1, WKT6

Ref. No.	Part No.	Description	Reqd. QTY				Serial No.	Parts catalogue code
			GX160K1					
			(1)	(2)	(3)	(4)		
17	91202-883-005	OIL SEAL, 25X41X6	1	(1)	-	1	-----	DS,DSP,EMA,EN,ET,ETX,HG1,HXE,HXQ,H1,LAX,LAX2,LDB1,LDB3,LDM,LD4,LHW,LJD,LMT,LSJ,LSS,LSS1,LSS4,LTA, LTK,NW,PH,PHU,PM,PM2,PX2,QA,QAB1,QAX,QBT2,QBU2,QM,QNT2,QWM2,QWX3,QXB,QXB1,QXF,QXQ,QXS,QXW2,QZ,RAC,REX4,RFR,RFR2,RHA,RNG,SAC,SAD2,SDB1,SDB3,SDN,SDS2,SDS3,SEE,SHR4,SJC,SMB4,SSK2,STA,STP,SWX,SW2,SWB,TH,THU,T1,UH,UX,U1,VA,VEB2,VED7,VH,VHQ4,VMB3,VS,VSDP,VSW,VS1,VTD,VTD1,VTE2,VTX,VTX1,VWA,VXE,VXE6,VXG,VXP,VXW,VXW1,VX26,V1
			1	(1)	-	-	-----	8565637 AR,ARC6,BL,EMA2,HG12,HH,HHQ4,HH26,HX,HXE2,HXE8,HXU,HX2,HX26,HX4,KR,KTA,LD,LH,LHB3,LHQ4,LJ,LJC7,LJG,LJS,LSJ4,LVL,LW2,LX,LXU,LX2,LX26,LX4,L1,NJ,NJC1,NJG,NSJ,PHM,PX,PXU,QAB3,QAX2,QA2,QA26,QBT6,QCB2,QCL,QD,QE,QFE4,QGR2,QGR9,QH,QHE,QHP1,QHQ4,QH26,QI2,QKA4,QMC6,QMC8,QMD6,QME4,QMH,QMX2,QMZ2,QNT,QNT4,QNZ,QP,QPU,QSC2,QSC9,QS2,QT,QVL,QWA4,QWX2,QX,QXC,QXC6,QXC9,QXE,QXE2,QXE4,QXE6,QXE8,QXF2,QXM1,QXS2,QXU,QXW,QX2,QX22,QX26,QX4,QX7,Q1,RD,RD4,RH,RHA2,RHQ4,RH2,RH26,RMB4,RMD,RMG2,RSK,RSS1,RTB2,RX,RXE,RXE2,RXE4,RXU,RX4,R1,SCJ,SD,SDS,SD16,SD4,SE,SG24,SH,SHM,SHQ4,SHRY,SJ,SJC1,SJC5,SJG,SKM,SMC7,SMC9,SMJ,SMJ1,SMW2,SMX4,SM11,SM12,SM14,SNX,SNX1,SSK1,SSX2,ST,STM,STQ,SWG4,SWX2,SWX4,SX,SXE,SXE4,SXS4,SXU,SX4,SX7,S1,S1CY,TCS2,TX,TXC9,TXU,TX2,TX26,TX4,UXU,VA2,VEBM,VED,VED1,VED2,VED3,VED5,VED6,VGE4,VG24,VHH4,VMS4,VMS7,VMT,VPM4,VPM7,VPR4,VPR7, VSB1,VSD,VSD1,VSD7,VSX,VSX1,VSX3,VS17,VS3,VS4,VTU1,VWA2,VW12,VX,VXD,VXD1,VXE4,VXE7,VXM,VXU,VXU1,VXW2,VX2,VX4,WDA6,WJP,WKD6,WKT2,WKT4,WKT6,WMB0,WME2,WME4,WMT,W1
			1	-	-	-	-----	8527259 QBC2,VEN2,VSG
			-	-	1	-	-----	
			-	-	-	1	-----	2000281 SXP1
	91201-Z0T-801	1	(1)	-	-	-----	8565638 AR,ARC6,BL,EMA2,HG12,HH,HHQ4,HH26,HX,HXE2,HXE8,HXU,HX2,HX26,HX4,KR,KTA,LD,LH,LHB3,LHQ4,LJ,LJC7,LJG,LJS,LSJ4,LVL,LW2,LX,LXU,LX2,LX26,LX4,L1,NJ,NJC1,NJG,NSJ,PHM,PX,PXU,QAB3,QAX2,QA2,QA26,QBT6,QCB2,QCL,QD,QE,QFE4,QGR2,QGR9,QH,QHE,QHP1,QHQ4,QH26,QI2,QKA4,QMC6,QMC8,QMD6,QME4,QMH,QMX2,QMZ2,QNT,QNT4,QNZ,QP,QPU,QSC2,QSC9,QS2,QT,QVL,QWA4,QWX2,QX,QXC,QXC6,QXC9,QXE,QXE2,QXE4,QXE6,QXE8,QXF2,QXM1,QXS2,QXU,QXW,QX2,QX22,QX26,QX4,QX7,Q1,RD,RD4,RH,RHA2,RHQ4,RH2,RH26,RMB4,RMD,RMG2,RSK,RSS1,RTB2,RX,RXE,RXE2,RXE4,RXU,RX4,R1,SCJ,SD,SDS,SD16,SD4,SE,SG24,SH,SHM,SHQ4,SHRY,SJ,SJC1,SJC5,SJG,SKM,SMC7,SMC9,SMJ,SMJ1,SMW2,SMX4,SM11,SM12,SM14,SNX,SNX1,SSK1,SSX2,ST,STM,STQ,SWG4,SWX2,SWX4,SX,SXE,SXE4,SXS4,SXU,SX4,SX7,S1,S1CY,TCS2,TX,TXC9,TXU,TX2,TX26,TX4,UXU,VA2,VEBM,VED,VED1,VED2,VED3,VED5,VED6,VGE4,VG24,VHH4,VMS4,VMS7,VMT,VPM4,VPM7,VPR4,VPR7, VSB1,VSD,VSD1,VSD7,VSX,VSX1,VSX3,VS17,VS3,VS4,VTU1,VWA2,VW12,VX,VXD,VXD1,VXE4,VXE7,VXM,VXU,VXU1,VXW2,VX2,VX4,WDA6,WJP,WKD6,WKT2,WKT4,WKT6,WMB0,WME2,WME4,WMT,W1
			1	-	-	-	-----	VES,VHA7,VPM5
			1	-	-	-	-----	8527260 QBC2,VEN2,VSG
			-	-	-	1	-----	2000282 SXP1



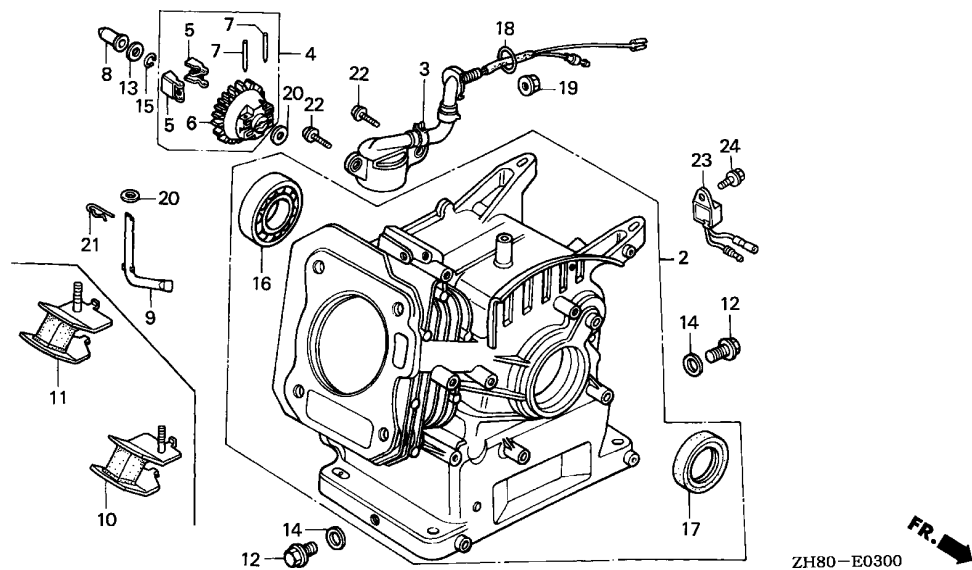

ZH80-E0300

2

Ref. No.	Part No.	Description	Reqd. QTY				Serial No.	Parts catalogue code
			(1)	(2)	(3)	(4)		
18	91353-671-004	O-RING, 14MM(NOK)	1	-	1	-	-----	EMA,EMA2,ETX,HG1,HG12,HX,HXE,HXE2,HXE8,HXQ,HXU,HX2,HX26,HX4,LAX,LAX2,LJC7,LX,LXU,LX2,LX26,LX4,PX,PXU,PX2,QAX,QAX2,QBT2,QBT6,QBU2,QCL,QGR2,QGR9,QI2,QKA4,QMC8,QMD6,QMH,QMX2,QNT,QNT2,QNT4,QSC2,QSC9,QS2,QWA4,QWM2,QWX2,QWX3,QX,QXB,QXB1,QXC,QXC6,QXC9,QXE,QXE2,QXE4,QXE6,QXE8,QXF,QXF2,QXM1,QXQ,QXS,QXS2,QXU,QXW,QXW2,QX2,QX22,QX26,QX4,QX7,RX,RXE,RXE2,RXE4,RXU,RX4,SAD2,SG24,SJC1,SJC5,SKM,SMC7,SMC9,SMJ,SMJ1,SMW2,SMX4,SM12,SM14,SNX,SNX1,SSX2,STM,SWG4,SWX,SWX2,SWX4,SX,SXB,SXE,SXE4,SXS4,SXU,SX4,SX7,TCS2,TX,TXC9,TXU,TX2,TX26,TX4,UX,UXU,VA,VA2,VEBM,VEB2,VED1,VED2,VED3,VED5,VED6,VED7,VEN2,VES,VGE4,VG24,VHA7,VHH4,VIH1,VMB3,VMS4,VMS7,VMT,VPM4,VPM5,VPM7,VPR4,VPR7,VSU1,VSD,VSD1,VSD7,VSG,VSW,VSX,VSX1,VSX3,VS17,VS3,VS4,VTD,VTD1,VTU1,VTX,VTX1,VWA,VWA2,VW12,VX,VXD,VXD1,VXE,VXE4,VXE6,VXE7,VXG,VXM,VXU,VXU1,VXW,VXW1,VXW2,VX2,VX26,VX4,WKD6,WKT2,WKT4,WKT6,WME2,WMT
			-	(1)	-	1		

Ref. No.	Part No.	Description	Reqd. QTY				Serial No.	Parts catalogue code
			(1)	(2)	(3)	(4)		
19	94050-10000	NUT, FLANGE, 10MM	1	-	1	-	-----	EMA,EMA2,ETX,HG1,HG12,HX,HXE,HXE2,HXE8,HXQ,HXU,HX2,HX26,HX4 LAX,LAX2,LJC7,LX,LXU,LX2,LX26,LX4,PX,PXU,PX2,QAX,QAX2,QBT2 QBT6,QBU2,QCL,QGR2,QGR9,QI2,QKA4,QMC8,QMD6,QMH,QMX2,QNT,QNT2 QNT4,QSC2,QSC9,QS2,QWA4,QWM2,QWX2,QWX3,QX,QXB,QXB1,QXC,QXC6 QXC9,QXE,QXE2,QXE4,QXE6,QXE8,QXF,QXF2,QXM1,QXQ,QXS,QXS2,QXU QXW,QXW2,QX2,QX22,QX26,QX4,QX7,RX,RXE,RXE2,RXE4,RXU,RX4,SAD2 SG24,SJC1,SJC5,SKM,SMC7,SMC9,SMJ,SMJ1,SMW2,SMX4,SM12,SM14,SNX SNX1,SSX2,STM,SWG4,SWX,SWX2,SWX4, SX, SXB, SXE, SXE4, SXS4, SXU, SX4 SX7,TCS2,TX,TXC9, TXU, TX2, TX26, TX4, UX, UXU, VA, VA2, VEBM, VEB2, VED1 VED2, VED3, VED5, VED6, VED7, VEN2, VES, VGE4, VG24, VHA7, VHH4, VIH1 VMB3, VMS4, VMS7, VMT, VPM4, VPM5, VPM7, VPR4, VPR7, VSB1, VSD, VSD1, VSD7 VSG, VSW, VSX, VSX1, VSX3, VS17, VS3, VS4, VTD, VTD1, VTU1, VTX, VTX1, VWA VWA2, VW12, VX, VXD, VXD1, VXE, VXE4, VXE6, VXE7, VXG, VXM, VXU, VXU1, VXW VXW1, VXW2, VX2, VX26, VX4, WKD6, WKT2, WKT4, WKT6, WME2, WMT
20	94101-06800	WASHER, PLAIN, 6MM	2	-	-	-	-----	AR,ARC6,BL,DS,DSP,EMA,EMA2,EN,ET,ETX,HG1,HG12,HH,HHQ4,HH26,HX HXE,HXE2,HXE8,HXQ,HXU,HX2,HX26,HX4,KR,KTA,LAX,LAX2,LD,LDB1 LDB3,LDM,LD4,LH,LHB3,LHQ4,LHW,LJ,LJC7,LJD,LJG,LJS,LMT,LSJ,LSJ4 LSS,LSS1,LSS4,LTA,LTK,LVL,LW2,LX,LXU,LX2,LX26,LX4,NJ,NJC1,NJG NSJ,NW,PH,PHM,PHU,PM,PM2,PX,PXU,PX2,QA,QAB1,QAB3,QAX,QAX2,QA2 QA26,QBC2,QBT2,QBT6,QBU2,QCB2,QCL,QD,QE,QFE4,QGR2,QGR9,QH,QHE QHP1,QHQ4,QH26,QI2,QKA4,QM,QMC6,QMC8,QMD6,QME4,QMH,QMX2,QM2 QNT,QNT2,QNT4,QNZ,QP,QPU,QSC2,QSC9,QS2,QT,QVL,QWA4,QWM2,QWX2 QWX3,QX,QXB,QXB1,QXC,QXC6,QXC9,QXE,QXE2,QXE4,QXE6,QXE8,QXF QXF2,QXM1,QXQ,QXS,QXS2,QXU,QXW,QXW2,QX2,QX22,QX26,QX4,QX7,RAC RD,RD4,REX4,RFR,RFR2,RH,RHA,RHA2,RHQ4,RH2,RH26,RMB4,RMD,RMG2 RNG,RSK,RSS1,RTB2,RX,RXE,RXE2,RXE4,RXU,RX4,SAC,SAD2,SJC,SD SDB1,SDB3,SDN,SDS,SDS2,SDS3,SD16,SD4,SE,SEE,SG24,SH,SHM,SHQ4 SHRY,SHR4,SJ,SJC,SJC1,SJC5,SJG,SKM,SMB4,SMC7,SMC9,SMJ,SMJ1 SMW2,SMX4,SM11,SM12,SM14,SNX,SNX1,SSK1,SSK2,SSX2,ST,STA,STM STP,STQ,SWG4,SWX,SWX2,SWX4,SW2,SX,SXB,SXE,SXE4,SXS4,SXU,SX4 SX7,S1CY,TCS2,TH,THU,TX,TXC9, TXU, TX2, TX26, TX4, UH, UX, UXU, VA, VA2 VEBM, VEB2, VED, VED1, VED2, VED3, VED5, VED6, VED7, VEN2, VES, VGE4, VG24 VH, VHA7, VHH4, VHQ4, VMB3, VMS4, VMS7, VMT, VPM4, VPM5, VPM7, VPR4, VPR7 VS, VSB1, VSD, VSD1, VSD7, VSG, VSW, VSX, VSX1, VSX3, VS1, VS17, VS3, VS4 VTD, VTD1, VTE2, VTU1, VTX, VTX1, VWA, VWA2, VW12, VX, VXD, VXD1, VXE, VXE4 VXE6, VXE7, VXG, VXM, VXU, VXU1, VXW, VXW1, VXW2, VX2, VX26, VX4, WDA6, WJP WKD6, WKT2, WKT4, WKT6, WMB0, WME2, WME4, WMT



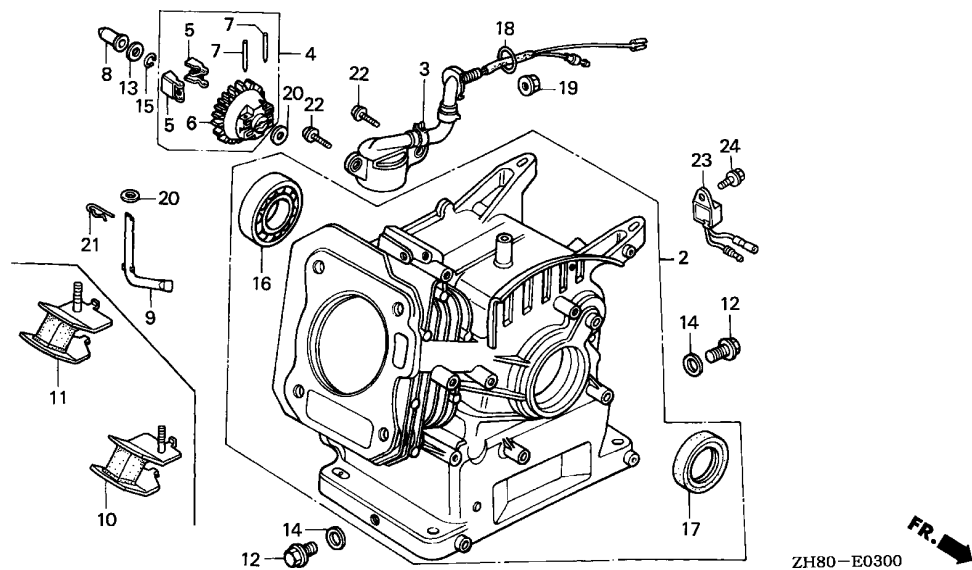

ZH80-E0300



2

Ref. No.	Part No.	Description	Reqd. QTY				Serial No.	Parts catalogue code
			(1)	(2)	(3)	(4)		
21	94251-08000	PIN, LOCK, 8MM	1	-	-	-	AR, ARC6, BL, DS, DSP, EMA, EMA2, EN, ET, ETX, HG1, HG12, HH, HHQ4, HH26, HX, HXE, HXE2, HXE8, HXQ, HXU, HX2, HX26, HX4, KR, KTA, LAX, LAX2, LD, LDB1, LDB3, LDM, LD4, LH, LHB3, LHQ4, LHW, LJ, LJ7, LJC7, LJD, LJG, LJS, LMT, LSJ, LSJ4, LSS, LSS1, LSS4, LTA, LTK, LVL, LW2, LX, LXU, LX2, LX26, LX4, NJ, NJC1, NJG, NSJ, NW, PH, PHM, PHU, PM, PM2, PX, PXU, PX2, QA, QAB1, QAB3, QAX, QAX2, QA2, QA26, QBC2, QBT2, QBT6, QBU2, QCB2, QCL, QD, QE, QFE4, QGR2, QGR9, QH, QHE, QHP1, QHQ4, QH26, QI2, QKA4, QM, QMC6, QMC8, QMD6, QME4, QMH, QMX2, QM2, QNT, QNT2, QNT4, QNZ, QP, QPU, QSC2, QSC9, QS2, QT, QVL, QWA4, QWM2, QWX2, QWX3, QX, QXB, QXB1, QXC, QXC6, QXC9, QXE, QXE2, QXE4, QXE6, QXE8, QXF, QXF2, QXM1, QXQ, QXS, QXS2, QXU, QXW, QXW2, QX2, QX22, QX26, QX4, QX7, RAC, RD, RD4, REX4, RFR, RFR2, RH, RHA, RHA2, RHQ4, RH2, RH26, RMB4, RMD, RMG2, RNG, RSK, RSS1, RTB2, RX, RXE, RXE2, RXE4, RXU, RX4, SAC, SAD2, SCJ, SD, SDB1, SDB3, SDN, SDS, SDS2, SDS3, SD16, SD4, SE, SEE, SG24, SH, SHM, SHQ4, SHRY, SHR4, SJ, SJC, SJC1, SJC5, SJG, SKM, SMB4, SMC7, SMC9, SMJ, SMJ1, SMW2, SMX4, SM11, SM12, SM14, SNX, SNX1, SSK1, SSK2, SSK2, ST, STA, STM, STP, STQ, SWG4, SWX, SWX2, SWX4, SW2, SX, SXB, SXE, SXE4, SXS4, SXU, SX4, SX7, S1CY, TCS2, TH, THU, TX, TXC9, TXU, TX2, TX26, TX4, UH, UX, UXU, VA, VA2, VEBM, VEB2, VED, VED1, VED2, VED3, VED5, VED6, VED7, VEN2, VES, VGE4, VG24, VH, VHA7, VHH4, VHQ4, VMB3, VMS4, VMS7, VMT, VPM4, VPM5, VPM7, VPR4, VPR7, VS, VSB1, VSD, VSD1, VSD7, VSG, VSW, VSX, VSX1, VSX3, VS1, VS17, VS3, VS4, VTD, VTD1, VTE2, VTU1, VTX, VTX1, VWA, VWA2, VW12, VX, VXD, VXD1, VXE, VXE4, VXE6, VXE7, VXG, VXM, VXU, VXU1, VXW, VXW1, VXW2, VX2, VX26, VX4, WDA6, WJP, WKD6, WKT2, WKT4, WKT6, WMBO, WME2, WME4, WMT	
			-	1	1	1		

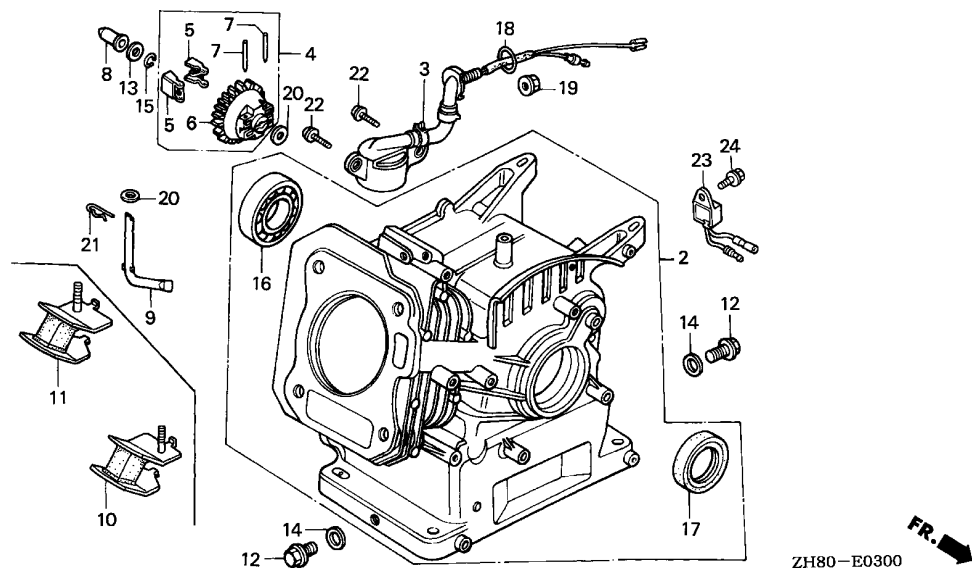

Ref. No.	Part No.	Description	Reqd. QTY				Serial No.	Parts catalogue code	
			(1)	(2)	(3)	(4)			
			GX160K1						
22	95701-06012-00	BOLT, FLANGE, 6X12	2	-	2	-	-----	EMA,EMA2,ETX,HG1,HG12,HX,HXE,HXE2,HXE8,HXQ,HXU,HX2,HX26,HX4,LAX,LAX2,LJC7,LX,LXU,LX2,LX26,LX4,PX,PXU,PX2,QAX,QAX2,QBT2,QBT6,QBU2,QCL,QGR2,QGR9,QI2,QKA4,QMC8,QMD6,QMH,QMX2,QNT,QNT2,QNT4,QSC2,QSC9,QS2,QWA4,QWM2,QWX2,QWX3,QX,QXB,QXB1,QXC,QXC6,QXC9,QXE,QXE2,QXE4,QXE6,QXE8,QXF,QXF2,QXM1,QXQ,QXS,QXS2,QXU,QXW,QXW2,QX2,QX22,QX26,QX4,QX7,RX,RXE,RXE2,RXE4,RXU,RX4,SAD2,SG24,SJC1,SJC5,SKM,SMC7,SMC9,SMJ,SMJ1,SMW2,SMX4,SM12,SM14,SNX,SNX1,SSX2,STM,SWG4,SWX,SWX2,SWX4,SX,SXB,SXE,SXE4,SXS4,SXU,SX4,SX7,TCS2,TX,TXC9,TXU,TX2,TX26,TX4,UX,UXU,VA,VA2,VEBM,VEB2,VED1,VED2,VED3,VED5,VED6,VED7,VEN2,VES,VGE4,VG24,VHA7,VHH4,VIH1,VMB3,VMS4,VMS7,VMT,VPM4,VPM5,VPM7,VPR4,VPR7,VSB1,VSD,VSD1,VSD7,VSG,VSW,VSX,VSX1,VSX3,VS17,VS3,VS4,VTD,VTD1,VTU1,VTX,VTX1,VWA,VWA2,VW12,VX,VXD,VXD1,VXE,VXE4,VXE6,VXE7,VXG,VXM,VXU,VXU1,VXW,VXW1,VXW2,VX2,VX26,VX4,WKD6,WKT2,WKT4,WKT6,WME2,WMT	
			-	(2)	-	2			
23	34150-ZH7-003	ALERT UNIT, OIL	1	-	-	-	-----	QCL,QGR9,QI2,QSC9,QS2,QWX3,QX22,SM12,SWX2,TCS2,VPM5	
			1	-	-	-	5372719	-----	QBT2,QWM2,QWX2,SG24,SSX2,VED7,VG24,WME2
24	95701-06008-00	BOLT, FLANGE, 6X8	1	-	-	-	-----	QCL,QGR9,QI2,QSC9,QS2,QWX3,QX22,SM12,SWX2,TCS2,VPM5	
			1	-	-	-	5372719	-----	QBT2,QWM2,QWX2,SG24,SSX2,VED7,VG24,WME2

E-6

CRANKCASE COVER(1)

G 7

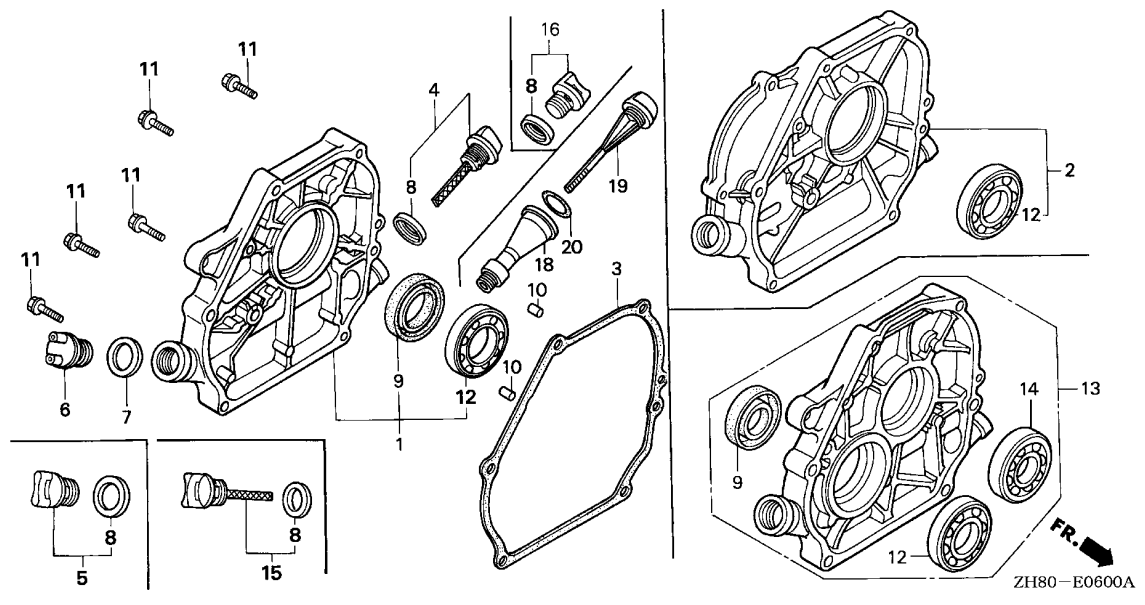

Ref. No.	L.O.N.	(Relative ref. Number) Description	F.R.T.
1	1101F1	COVER, CRANKCASE	0.2
3	1101E9	PACKING, CASE COVER	0.2
9	1101E5	OIL SEAL, CRANKSHAFT :REAR ...	0.3
	2141L5	OIL SEAL, POWER TAKE OFF SHAFT :REAR	0.3
12	1101A6	BEARING, CRANKSHAFT :REAR	0.4
	2141L0	BEARING, POWER TAKE OFF SHAFT :REAR	0.4
14	1101A6	BEARING, CRANKSHAFT :REAR	0.4
18	1101B9	EXTENSION, OIL FILLER AND/OR PACKING, EXTENSION OIL FILLER	0.1

2

Ref. No.	Part No.	Description	Reqd. QTY				Serial No.	Parts catalogue code
			(1)	GX160K1 (2)	(3)	(4)		
1	11300-ZE1-010	COVER ASSY., CRANKCASE	1	1	-	-	8571217	RD, RD4, RH, RHA2, RHQ4, RH2, RH26, RMB4, RMD, RMG2, RSK, RSS1, RTB2, RX RXE, RXE2, RXE4, RXU, RX4, R1, SWX2, SWX4 RAC, REX4, RFR, RFR2, RHA, RNG, SAC, SDN, SEE, SWX, SW2
	11300-ZE1-633	1	1	-	-	2000281	SXP1
			1	-	1	-	8565637	BL, EMA2, HG12, HH, HHQ4, HH26, HX, HXE2, HXE8, HXU, HX2, HX26, HX4, KTA SCJ, SD, SDS, SD16, SD4, SE, SG24, SH, SHM, SHQ4, SHRY, SJ, SJC1, SJC5, SJG SKM, SMC7, SMC9, SMJ, SMJ1, SMW2, SMX4, SM11, SM12, SM14, SNX, SNX1, SSK1 SXS2, ST, STM, STQ, SWG4, SX, SXE, SXE4, SXS4, SXU, SX4, SX7, S1, S1CY, VED VED1, VED2, VED3, VED5, VED6, VSB1, VSX, VSX1, VSX3, VS3, VS4, VXD, VXD1 WDA6, WJP, WKD6, WKT2, WKT4, WKT6, WMB0, WME2, WME4, WMT, W1
			1	-	1	-		EMA, EN, ET, ETX, HG1, HXE, HXQ, SAD2, SDB1, SDB3, SDS2, SDS3, SHR4, SJC SMB4, SSK2, STA, STP, SXB, VED7, VS, VSW, VS1, VTD, VTD1, VTE2, VTX, VTX1 WIH1
	11300-ZE1-641	1	-	-	-	8527259	VEN2, VSG
			1	1	1	1		PH, PHU, PM, PM2, PX2, QA, QAB1, QAX, QBT2, QBU2, QIH1, QM, QNT2, QWM2, QWX3 QXB, QXB1, QXF, QXQ, QXS, QXW2, QZ, TH, THU, T1, UH, UIH, UX, VA, VEB2, VH VHQ4, VIH1, VMB3, VSDP, VWA, VXE, VXE6, VXG, VXP, VXW, VXW1, VX26, V1
			1	1	-	-	8566783	PHM, PX, PXU, QAB3, QAX2, QA2, QA26, QBT6, QCB2, QCL, QD, QE, QFE4, QGR2 QGR9, QH, QHE, QHP1, QHQ4, QH26, QI2, QKA4, QMC6, QMC8, QMD6, QME4, QMH QMX2, QMZ2, QNT, QNT4, QNZ, QP, QPU, QSC2, QSC9, QS2, QT, QVL, QWA4, QWX2 QX, QXC, QXC6, QXC9, QXE, QXE2, QXE4, QXE6, QXE8, QXF2, QXM1, QXS2, QXU QXW, QX2, QX22, QX26, QX4, QX7, Q1, TCS2, TX, TXC9, TXU, TX2, TX26, TX4, UXU VA2, VEBM, VGE4, VG24, VHH4, VMS4, VMS7, VPM4, VPM7, VPR4, VPR7, VSD, VSD1 VSD7, VS17, VTU1, VWA2, VW12, VX, VXE4, VXE7, VXM, VXU, VXU1, VXW2, VX2 VX4
			1	-	-	-	8531480	QBC2

Ref. No.	Part No.	Description	Reqd. QTY				Serial No.	Parts catalogue code
			(1)	GX160K1 (2)	(3)	(4)		
(1)	11300-ZE1-020	COVER ASSY., CRANKCASE	1	1	-	-	8571218 ----- RD, RD4, RH, RHA2, RHQ4, RH2, RH26, RMB4, RMD, RMG2, RSK, RSS1, RTB2, RX RXE, RXE2, RXE4, RXU, RX4, R1, SWX2, SWX4	
	11300-ZE1-634	1	1	-	-	2000282 ----- SXP1 8565638 ----- BL, EMA2, HG12, HH, HHQ4, HH26, HX, HXE2, HXE8, HXU, HX2, HX26, HX4, KTA SCJ, SD, SDS, SD16, SD4, SE, SG24, SH, SHM, SHQ4, SHRY, SJ, SJC1, SJC5, SJG SKM, SMC7, SMC9, SMJ, SMJ1, SMW2, SMX4, SM11, SM12, SM14, SNX, SNX1, SSK1 SXS2, ST, STM, STQ, SWG4, SX, SXE, SXE4, SXS4, SXU, SX4, SX7, S1, S1CY, VED VED1, VED2, VED3, VED5, VED6, VSB1, VSX, VSX1, VSX3, VS3, VS4, VXD, VXD1 WDA6, WJP, WKD6, WKT2, WKT4, WKT6, WMBO, WME2, WME4, WMT, W1	
	11300-ZE1-642	1	-	-	-	8527260 ----- VES 8566784 ----- VEN2, VSG	
			1	-	-	-	PHM, PX, PXU, QAB3, QAX2, QA2, QA26, QBT6, QCB2, QCL, QD, QE, QFE4, QGR2 QGR9, QH, QHE, QHP1, QHQ4, QH26, QI2, QKA4, QMC6, QMC8, QMD6, QME4, QMH QMX2, QMZ2, QNT, QNT4, QNZ, QP, QPU, QSC2, QSC9, QS2, QT, QVL, QWA4, QWX2 QX, QXC, QXC6, QXC9, QXE, QXE2, QXE4, QXE6, QXE8, QXF2, QXM1, QXS2, QXU QXW, QX2, QX22, QX26, QX4, QX7, Q1, TCS2, TX, TXC9, TXU, TX2, TX26, TX4, UXU VA2, VEBM, VGE4, VG24, VHH4, VMS4, VMS7, VPM4, VPM7, VPR4, VPR7, VSD, VSD1 VSD7, VS17, VTU1, VWA2, VW12, VX, VXE4, VXE7, VXM, VXU, VXU1, VXW2, VX2 VX4	
			1	-	-	-	VHA7, VPM5	
			1	-	-	-	8531481 ----- QBC2	
2	11300-ZE1-613	COVER ASSY., CRANKCASE	1	1	-	-	DS, DSP, LAX, LAX2, LD, LDB1, LDB3, LDM, LD4, LH, LHB3, LHQ4, LHW, LJ, LJJC7 LJD, LJG, LJS, LMT, LSJ, LSJ4, LSS, LSS1, LSS4, LTA, LTK, LVL, LW2, LX, LXU LX2, LX26, LX4, L1	
3	11381-ZB2-800	PACKING, CASE COVER	1	-	-	-	2526787 VED2, VS3	
	11381-ZE1-000	1	-	-	-	2598206 EN, ET, ETX, KTA, LTA, LW2, PM, PM2, QM, QT, QZ, SEE, STA, SWX, SW2, VEBM	
			1	-	-	-	2630823 DS, DSP, LJ, LJS, LMT, LTK, SCJ, SJ, SKM, SMJ, SMJ1, ST, STP, STQ	
			-	(1)	-	-	2598206	
	11381-ZH8-800	PACKING, CASE COVER (NON ASBEST)	1	(1)	-	-	2598207 3413169 EN, ET, ETX, KTA, LTA, LW2, L1, PM, PM2, QM, QT, QZ, Q1, R1, SEE, STA, SWX, SW2 S1, T1, VEBM, V1, W1	
			1	-	-	-	3413169 EMA, HG1, HH, HHQ4, HX, HXQ, HX2, HX4, LD, LD4, LH, LHQ4, LJD, LJG, LSS, LX LX2, LX4, PH, PHU, PX, PX2, QA, QAX, QA2, QD, QE, QGR2, QH, QHE, QHQ4, QNT QNZ, QX, QXB, QXC, QXE, QXE2, QXE4, QXF, QXF2, QXQ, QXS, QXS2, QXW, QX2, QX4 RAC, RD, RD4, RFR, RH, RHA, RHQ4, RH2, RMD, RSK, RX, RXE, RXE4, RX4, SAC, SD SDB1, SDS, SD4, SE, SH, SHQ4, SJG, SNX, SSK1, STM, SX, SXB, SXE, SXE4, SX4 TH, THU, TX, TX2, TX4, UH, UX, VA, VED, VED1, VED3, VH, VHQ4, VS, VSD, VSD1 VSX, VSX1, VS1, VS4, VWA, VX, VXE, VXE4, VXG, VXU, VXW, VXW1, VXW2, VX2, VX4 WJP, WMT	
			1	-	-	-	2526788 3413169 VED2, VS3	
			1	-	-	-	2630824 3413169 DS, DSP, LJ, LJS, LMT, LTK, SCJ, SJ, SKM, SMJ, SMJ1, ST, STP, STQ	
			-	(1)	-	-	2598207 ----- H1, U1	



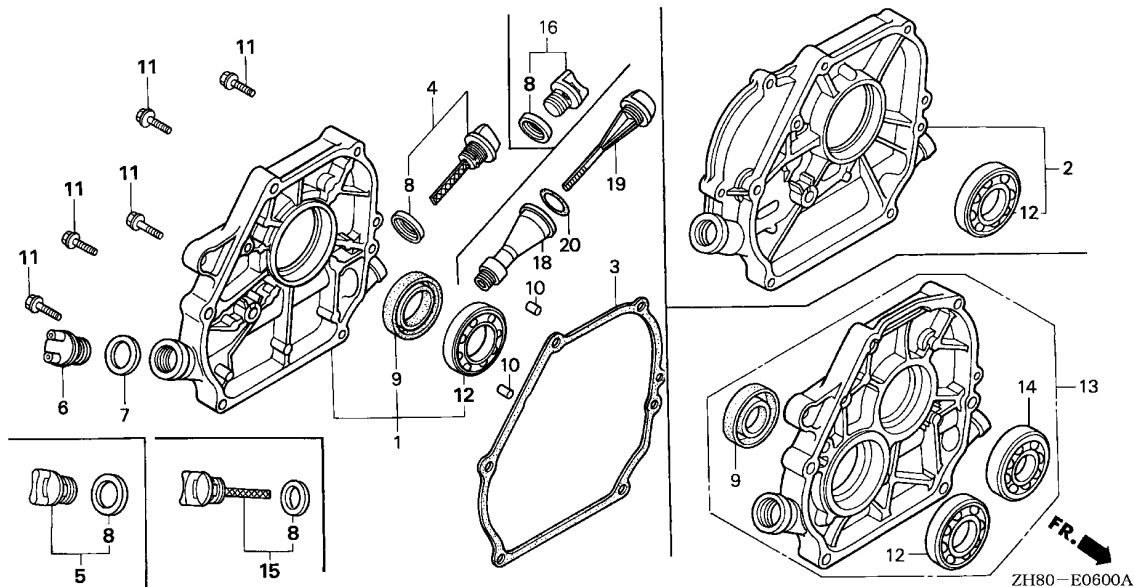

Ref. No.	Part No.	Description	Reqd. QTY				Serial No.	Parts catalogue code
			(1)	(2)	(3)	(4)		
			GX160K1					
(3)	11381-ZH8-801	PACKING, CASE COVER (NON ASBEST)	1	(1)	-	-	3413170	DS,DSP,EMA,EN,ET,ETX,HG1,HH,HHQ4,HX,HXQ,HX2,HX4,KTA,LD,LD4,LH,LHQ4,LJ,LJD,LJG,LJS,LMT,LSS,LTA,LTK,LW2,LX,LX2,LX4,L1,PH,PHU,PM,PM2,PX,PX2,QA,QAX,QA2,QD,QE,QGR2,QH,QHE,QHQ4,QM,QNT,QNZ,QT,QX,QXB,QXC,QXE,QXE2,QXE4,QXF,QXF2,QXQ,QXS,QXS2,QXW,QX2,QX4,QZ,Q1,R1,SAC,SCJ,SD,SDB1,SDS,SD4,SE,SEE,SH,SHQ4,SJ,SJG,SKM,SMJ,SMJ1,SNX,SSK1,ST,STA,STP,STQ,SWX,SW2,SX,AXB,SXE,SXE4,SX4,S1,THU,TX,TX2,TX4,T1,UH,UX,VA,VEBM,VED,VED1,VED3,VH,VHQ4,VS,VSD,VSD1,VSX,VSX1,VS1,VS3,VS4,VVA,VX,VXE,VXE4,VXG,VXU,VXW,VXW1,VXW2,VX2,VX4,V1,WJP,WMT,W1
			1	-	-	-		BL,EMA2,HG12,HH26,HXE,HXE2,HXE8,HXU,HX26,LAX2,LDB1,LDB3,LDM,LHB3,LHW,LJC7,LSJ,LSJ4,LSS1,LSS4,LVL,LXU,LX26,NJ,NJC1,NJG,NSJ,NW,PHM,PXU,QAB1,QAB3,QAX2,QA26,QBC2,QBT2,QBT6,QBU2,QCL,QFE4,QGR9,QHP1,QH26,QI2,QKA4,QMC6,QMC8,QMD6,QME4,QMH,QMX2,QM22,QNT2,QNT4,QP,QPU,QSC2,QSC9,QS2,QVL,QWA4,QWM2,QWX2,QWX3,QXC6,QXC9,QXE6,QXE8,QXM1,QXU,QXW2,QX22,QX26,QX7,SAD2,SDB3,SDN,SDS2,SDS3,SD16,SG24,SHM,SHRY,SHR4,SJC,SJC1,SJC5,SMB4,SMC7,SMC9,SMW2,SMX4,SM11,SM12,SM14,SNX1,SSK2,SSX2,STM,SWG4,SWX2,SWX4,SXS4,SXU,SX7,S1CY,TCS2,TCX9,TXU,TX26,UXU,VA2,VEB2,VED2,VED5,VED6,VED7,VEN2,VES,VGE4,VG24,VHA7,VHH4,VMB3,VMS4,VMS7,VPM4,VPM5,VPM7,VPR4,VPR7,VSB1,VSD7,VSG,VSW,VSX3,VS17,VTD,VTD1,VTE2,VTU1,VTX,VTX1,VWA2,VW12,VXD,VXD1,VXE6,VXE7,VXM,VXU1,VX26,WDA6,WKD6,WKT2,WKT4,WKT6,WMB0,WME2,WME4
			1	-	-	-	4067884	RFR2,RHA2,RH26,RMB4,RMG2,RNG,RTB2
			1	-	-	-	3413170	RAC,RD,RD4,RFR,RH,RHA,RHQ4,RH2,RMD,RSK,RX,RXE,RXE4,RX4
			(1)	-	-	-		QXB1
			-	-	1	1		

Ref. No.	Part No.	Description	Reqd. QTY				Serial No.	Parts catalogue code
			(1)	(2)	(3)	(4)		
(3)	11381-ZL0-000	PACKING, CASE COVER	1	-	-	-	QCB2, REX4, RSS1, RXE2, RXU	
			1	-	-	4067885	RAC, RD, RD4, RFR, RFR2, RH, RHA, RHA2, RHQ4, RH2, RH26, RMB4, RMD, RMG2, RNG, RSK, RTB2, RX, RXE, RXE4, RX4	
4	15600-ZE1-000	CAP ASSY., OIL FILLER (GRAY)	1	-	-	-	VED3	
			1	-	-	2899521	DS, DSP, EN, ET, ETX, HH, KTA, LAX, LD, LH, LJ, LJS, LMT, LTK, LX, PH, PX, QD, QE, QH, QHE, QNT, QXB, QXW, RD, RMD, RSK, RX, RXE, SCJ, SD, SE, SH, SJ, SMJ1, ST, STA, STP, STQ, SX, SXB, SXE, TH, UH, UX, VA, VEBM, VED, VED1, VED2, VH, VS, VSD, VSD1, VSX, VSX1, VS1, VS3, VS4, VXE	
			1	-	-	2966709	HG1, HX, HXQ, HX2, LX2, PX2, QA, QA2, QX, QXC, QXE, QXE2, QXF, QXF2, QXQ, QXS, QXS2, QX2, RH, RHA, RH2, TX, TX2, VWA, VX, VXW, VXW2, VX2	
			2	-	-	2286377	SMJ	
			-	1	-	2899521		
	15600-ZF0-000	CAP ASSY., OIL FILLER	1	-	-	2898807	LTA, LW2, PM, PM2, QM, QT, QZ, RAC, SAC, SDS, SEE, SWX, SW2	
			-	-	1		UIH	
	15600-ZE1-003	CAP ASSY., OIL FILLER (GRAY)	1	-	1	-	BL, EMA, EMA2, HG12, HHQ4, HH26, HXE, HXE2, HXE8, HXU, HX26, HX4, LAX2, LDB1, LDB3, LDM, LD4, LHB3, LHQ4, LHW, LJC7, LJD, LJG, LSJ, LSJ4, LSS, LSS1, LSS4, LVL, LXU, LX26, LX4, NJ, NJC1, NJG, NSJ, NW, PHM, PHU, PXU, QAB1, QAB3, QAX, QAX2, QA26, QBC2, QBT2, QBT6, QBU2, QCB2, QCL, QFE4, QGR2, QGR9, QHP1, QHQ4, QH26, QI2, QKA4, QMC6, QMC8, QMD6, QME4, QMH, QMX2, QMZ2, QNT2, QNT4, QNZ, QP, QPU, QSC2, QSC9, QS2, QVL, QWA4, QWM2, QWX2, QWX3, QXB1, QXC6, QXC9, QXE4, QXE6, QXE8, QXM1, QXU, QXW2, QX22, QX26, QX4, QX7, RD4, REX4, RHA2, RHQ4, RH26, RMB4, RMG2, RNG, RSS1, RTB2, RXE2, RXE4, RXU, RX4, SAD2, SDB1, SDB3, SDS2, SDS3, SD16, SD4, SG24, SHM, SHQ4, SHRY, SHR4, SJC, SJC1, SJC5, SJG, SMB4, SMC7, SMC9, SMW2, SMX4, SM11, SM12, SM14, SNX, SNX1, SSK2, SSK2, SSSX2, STM, SWG4, SXE4, SXS4, SXU, SX4, SX7, S1CY, TCS2, THU, TXC9, TXU, TX26, TX4, UXU, VA2, VEB2, VED2, VED5, VED6, VED7, VEN2, VES, VGE4, VG24, VHA7, VHH4, VHQ4, VIH1, VMB3, VMS4, VMS7, VPM4, VPM5, VPM7, VPR4, VPR7, VSB1, VSD7, VSG, VSW, VSX3, VS17, VTD, VTD1, VTE2, VTU1, VTX, VTX1, VWA2, VW12, VXD, VXD1, VXE4, VXE6, VXE7, VXG, VXM, VXU, VXU1, VXW1, VX26, VX4, WDA6, WJP, WKD6, WKT2, WKT4, WKT6, WMBO, WME2, WME4, WMT	
			1	-	-	2899522	DS, DSP, EN, ET, ETX, HH, KTA, LAX, LD, LH, LJ, LJS, LMT, LTK, LX, PH, PX, QD, QE, QH, QHE, QNT, QXB, QXW, RD, RMD, RSK, RX, RXE, SCJ, SD, SE, SH, SJ, SMJ1, SMJ1, ST, STA, STP, STQ, SX, SXB, SXE, TH, UH, UX, VA, VEBM, VED, VED1, VED3, VH, VS, VSD, VSD1, VSX, VSX1, VS1, VS3, VS4, VXE	
			1	-	-	2966710	HG1, HX, HXQ, HX2, LX2, PX2, QA, QA2, QX, QXC, QXE, QXE2, QXF, QXF2, QXQ, QXS, QXS2, QX2, RH, RHA, RH2, TX, TX2, VWA, VX, VXW, VXW2, VX2	
			-	1	-	2899522		
			-	-	1			
	15600-ZF0-003	CAP ASSY., OIL FILLER	1	-	1	-	QIH1, SDN, UIH, WIH1	
			1	-	-	2898808	LTA, LW2, PM, PM2, QM, QT, QZ, RAC, SAC, SDS, SEE, SWX, SW2	



E-6

CRANKCASE COVER(1)

G11

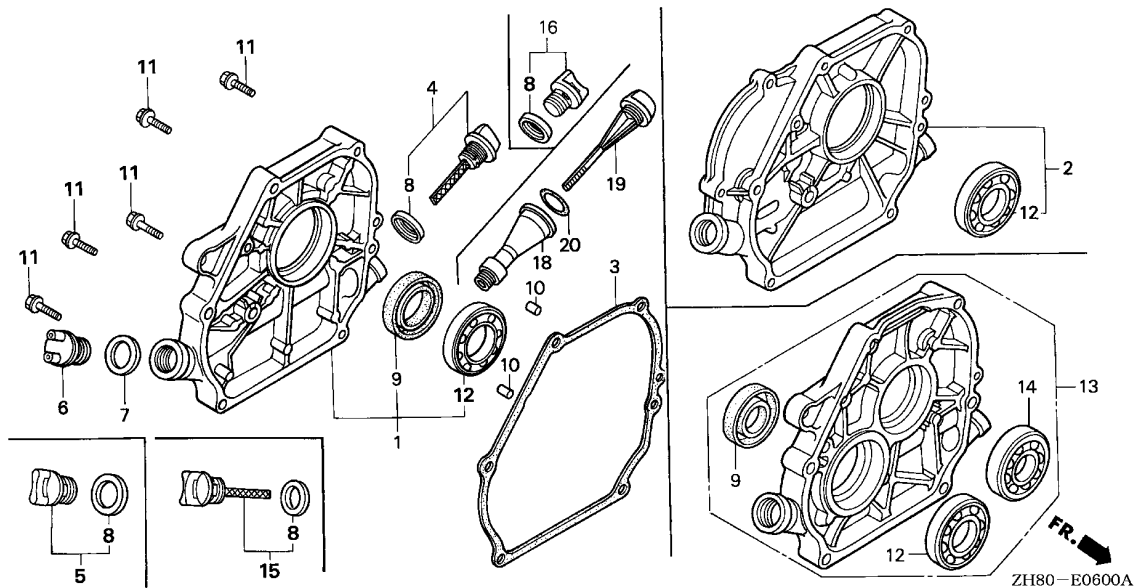

2

Ref. No.	Part No.	Description	Reqd. QTY				Serial No.	Parts catalogue code	
			(1)	(2)	(3)	(4)			
			GX160K1						
5	15600-ZG4-003	CAP ASSY., OIL FILLER	1	-	-	-	-----	BL,EMA,EMA2,HG12,HHQ4,HH26,HXE,HXE2,HXE8,HXU,HX26,HX4,LAX2,LDB1,LDB3,LDM,LD4,LHB3,LHQ4,LHW,LJC7,LJD,LJG,LSJ,LSJ4,LSS,LSS1,LSS4,LVL,LXU,LX26,LX4,NJ,NJC1,NJG,NSJ,NW,PHM,PHU,PXU,QAB1,QAB3,QAX,QAX2,QA26,QBC2,QBT2,QBT6,QBU2,QCB2,QCL,QFE4,QGR2,QGR9,QHP1,QHQ4,QH26,QI2,QKA4,QMC6,QMC8,QMD6,QME4,QMH,QMX2,QMZ2,QNT2,QNT4,QNZ,QP,QPU,QSC2,QSC9,QS2,QVL,QWA4,QWM2,QWX2,QWX3,QXC6,QXC9,QXE4,QXE6,QXE8,QXM1,QXU,QXW2,QX22,QX26,QX4,QX7,RD4,REX4,RFR2,RHA2,RHQ4,RH26,RMB4,RMG2,RNG,RSS1,RTB2,RXE2,RXE4,RXU,RX4,SAD2,SDB1,SDB3,SDN,SDS2,SDS3,SD16,SD4,SG24,SHM,SHQ4,SHRY,SHR4,SJC,SJC1,SJC5,SJG,SMB4,SMC7,SMC9,SMW2,SMX4,SM11,SM12,SM14,SNX,SNX1,SSK1,SSK2,SSX2,STM,SWG4,SXE4,SXS4,SXU,SX4,SX7,S1CY,TC2,THU,TXC9,TXU,TX26,TX4,UXU,VA2,VEB2,VED2,VED5,VED6,VED7,VEN2,VES,VGE4,VG24,VHA7,VHH4,VHQ4,VMB3,VMS4,VMS7,VPM4,VPM5,VPM7,VPR4,VPR7,VSB1,VSD7,VSG,VSW,VSX3,VS17,VTD,VTD1,VTE2,VTU1,VTX,VTX1,VWA2,VW12,VXD,VXD1,VXE4,VXE6,VXE7,VXG,VXM,VXU,VXU1,VXW1,VX26,VX4,WDA6,WJP,WKD6,WKT2,WKT4,WKT6,WMB0,WME2,WME4,WMT	
			1	-	-	-	2899522	-----	DS,DSP,EN,ET,ETX,HH,KTA,LAX,LD,LH,LJ,LJS,LMT,LTA,LTk,LW2,LX,PH,PM,PM2,PX,QD,QE,QH,QHE,QM,QNT,QT,QXB,QXW,QZ,RAC,RD,RMD,RSK,RX,RXE,SAC,SCJ,SD,SDS,SE,SEE,SH,SJ,SKM,SMJ,ST,STA,STP,STQ,SWX,SW2,SX,SXB,SXE,TH,UH,UX,VA,VEBM,VED,VED1,VED3,VH,VS,VSD,VSD1,VSX,VSX1,VS1,VS3,VS4,VXE
			1	-	-	-	2966710	-----	HG1,HX,HXQ,HX2,LX2,PX2,QA,QA2,QX,QXC,QXE,QXE2,QXF,QXF2,QXQ,QXS,QXS2,QX2,RFR,RH,RHA,RH2,TX,TX2,VWA,VX,VXW,VXW2,VX2
			1	-	-	-	3824882	-----	QXB1
			-	1	-	-	2899522		
			-	-	1	1			

Ref. No.	Part No.	Description	Reqd. QTY				Serial No.	Parts catalogue code	
			(1)	GX160K1 (2)	(3)	(4)			
6	15620-ZG4-910	CAP, OIL FILLER	1	1	-	-	2899521	DS,DSP,LJ,LJS,LMT,LTK,L1,Q1,RMD,R1,SCJ,SJ,SKM,SMJ1,ST,STA,STP,STQ,S1,T1,VED3,V1,W1	
			1	-	-	-	2966709	HG1,HX,HXQ,HX2,LX2,PX2,QA,QA2,QX,QXC,QXE,QXE2,QXF,QXF2,QXQ,QXS,QXS2,QX2,RFR,RH,RHA,RH2,TX,TX2,VWA,VX,VXW,VXW2,VX2	
			1	-	-	-	2286378	2899521	SMJ
			-	1	-	-	-	-	H1,U1
7	15621-896-010	PACKING, OIL FILLER CAP	1	-	-	-	2899521	DS,DSP,EN,ET,ETX,HH,KTA,LAX,LD,LH,LJ,LJS,LMT,LTA,LTK,LW2,LX,PH,PM,PM2,PX,QD,QE,QH,QHE,QM,QNT,QT,QXB,QXW,QZ,RAC,RD,RMD,RSK,RXRXE,SAC,SCJ,SD,SDS,SE,SEE,SH,SJ,SKM,SMJ1,ST,STA,STP,STQ,SWX,SW2,SX,SXB,SXE,TH,UH,UX,VA,VEBM,VED,VED1,VED2,VED3,VH,VS,VSD,VSD1,VSX,VSX1,VS1,VS3,VS4,VXE	
			1	-	-	-	2966709	HG1,HX,HXQ,HX2,LX2,PX2,QA,QA2,QX,QXC,QXE,QXE2,QXF,QXF2,QXQ,QXS,QXS2,QX2,RFR,RH,RHA,RH2,TX,TX2,VWA,VX,VXW,VXW2,VX2	
			1	-	-	-	3824881	QXB1	
			1	-	-	-	2286378	2899521	SMJ
8	15625-ZE1-000	PACKING, OIL FILLER CAP	-	1	-	-	2899521	UIH	
			1	-	-	-	2899521	DS,DSP,EN,ET,ETX,HH,KTA,LAX,LD,LH,LJ,LJS,LMT,LTA,LTK,LW2,LX,PH,PM,PM2,PX,QD,QE,QH,QHE,QM,QNT,QT,QXB,QXW,QZ,RAC,RD,RMD,RSK,RXRXE,SAC,SCJ,SD,SDS,SE,SEE,SH,SJ,SMJ1,ST,STA,STP,STQ,SWX,SW2,SX,SXB,SXE,TH,UH,UX,VA,VEBM,VED,VED1,VED2,VH,VS,VSD,VSD1,VSX,VSX1,VS1,VS3,VS4,VXE	
			1	-	-	-	2942671	VED3	
			1	-	-	-	2966709	HG1,HX,HXQ,HX2,LX2,PX2,QA,QA2,QX,QXC,QXE,QXE2,QXF,QXF2,QXQ,QXS,QXS2,QX2,RH,RHA,RH2,TX,TX2,VWA,VX,VXW,VXW2,VX2	
			1	-	-	-	3824881	QXB1	
			2	-	-	-	2286377	SMJ	
-	1	-	-	2899521	2899521	SMJ			
-	-	1	-	-	-	UIH			



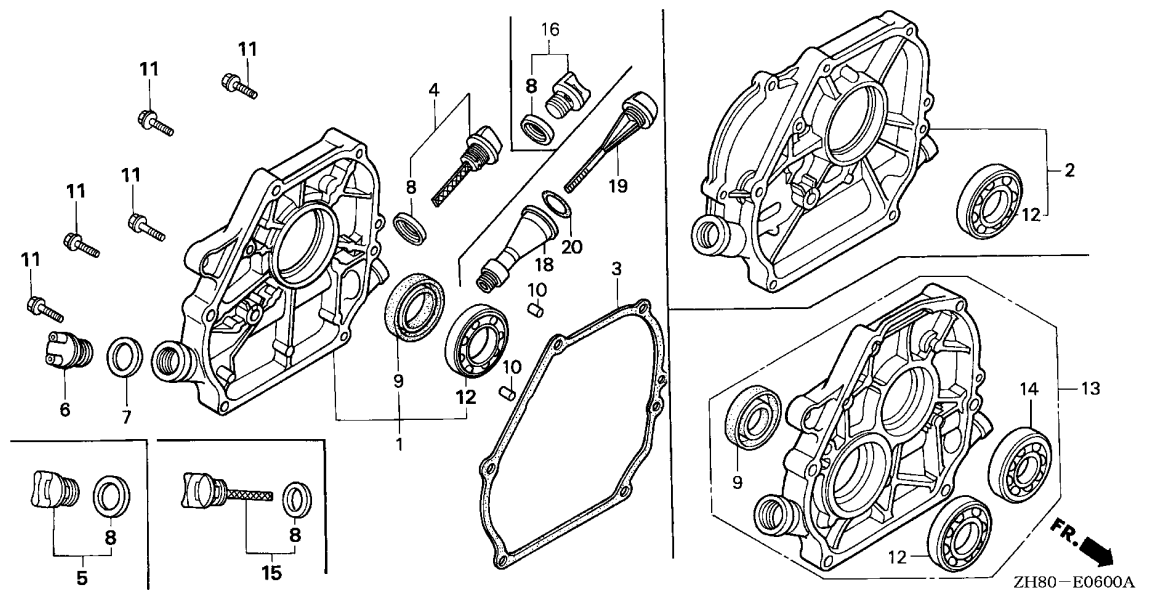

Ref. No.	Part No.	Description	Reqd. QTY				Serial No.	Parts catalogue code
			(1)	(2)	(3)	(4)		
(8)	15625-ZE1-003	PACKING, OIL FILLER CAP	2	-	-	2	-----	BL,EMA2,HG12,HHQ4,HH26,HXE,HXE2,HXE8,HXU,HX26,HX4,LAX2,LDB1,LDB3,LDM,LD4,LHB3,LHQ4,LHW,LSJ4,LSS4,LVL,LXU,LX26,LX4,NW,PHM,PHU,PXU,QAB1,QAB3,QAX,QAX2,QA26,QBC2,QBT2,QBT6,QBU2,QCB2,QCL,QFE4,QGR2,QGR9,QHP1,QHQ4,QH26,QI2,QKA4,QMC6,QMC8,QMD6,QME4,QMH,QMX2,QMZ2,QNT2,QNT4,QNZ,QP,QPU,QSC2,QSC9,QS2,QVL,QWA4,QWM2,QWX2,QWX3,QXC6,QXC9,QXE4,QXE6,QXE8,QXU,QXW2,QX22,QX26,QX4,QX7,RD4,REX4,RHA2,RHQ4,RH26,RMB4,RMG2,RTB2,RXE2,RXE4,RXU,RX4,SAD2,SDB1,SDB3,SDN,SDS2,SDS3,SD16,SD4,SG24,SHM,SHQ4,SHR4,SMB4,SMC7,SMC9,SMW2,SMX4,SM12,SM14,SSK2,SSX2,SWG4,SWX2,SWX4,SXE4,SXS4,SXU,SX4,SX7,TCS2,THU,TXC9,TXU,TX26,TX4,UXU,VA2,VEB2,VED2,VED6,VED7,VEN2,VES,VGE4,VG24,VHA7,VHH4,VHQ4,VMB3,VMS4,VMS7,VPM4,VPM5,VPM7,VPR4,VPR7,VSB1,VSDP,VSD7,VSG,VSW,VSX3,VS17,VTD,VTD1,VTE2,VTU1,VTX,VTX1,VWA2,VN12,VXE4,VXE6,VXE7,VXG,VXM,VXP,VXU,VXU1,VXW1,VX26,VX4,WDA6,WKD6,WKT2,WKT4,WKT6,WMB0,WME2,WME4

Ref. No.	Part No.	Description	Reqd. QTY				Serial No.	Parts catalogue code
			(1)	(2)	(3)	(4)		
(8)	15625-ZE1-003	PACKING, OIL FILLER CAP	2	-	-	-	2899522	----- EN,ET,ETX,HH,KTA,LAX,LD,LH,LTA,LW2,LX,PH,PM,PM2,PX,QD,QE,QH QHE,QM,QNT,QT,QXB,QXW,QZ,RAC,RD,RSK,RX,RXE,SAC,SD,SDS,SE,SEE SH,SMJ1,STA,SWX,SW2,SX,SWB,SXE,TH,UH,UX,VA,VEBM,VED,VED1,VH,VS VSD,VSD1,VSX,VSX1,VS1,VS3,VS4,VXE
			2	-	-	-	2942672	----- VED3
			2	-	-	-	2966710	----- HG1,HX,HXQ,HX2,LX2,FX2,QA,QA2,QX,QXC,QXE,QXE2,QXF,QXF2,QXQ,QXS QXS2,QX2,RFR,RH,RHA,RH2,FX,FX2,VWA,VX,VXW,VXW2,VX2
			2	-	-	-	3824882	----- QXB1
			-	2	-	-	2899522	
			-	-	2	-		
			1	1	-	-	2899522	----- DS,DSP,LJ,LJS,LMT,LTK,L1,Q1,RMD,R1,SCJ,SJ,SKM,SMJ,ST,STA,STP STQ,S1,T1,VED3,V1,W1
			1	-	-	2		----- EMA,LJC7,LJD,LJG,LSJ,LSS,LSS1,NJ,NJC1,NJG,NSJ,QXM1,RFR2,RNG RSS1,SHRY,SJC,SJC1,SJC5,SJG,SM11,SNX,SNX1,SSK1,STM,SXP1,S1CY VED5,VXD,VXD1,WJP,WMT
			1	1	-	1		----- EMA,EN,ET,ETX,HG1,HXE,HXQ,H1,LSJ,NW,PH,PHU,PM,PM2,FX2,QA,QAB1 QAX,QBT2,QBU2,QM,QNT2,QWM2,QWX3,QXB,QXB1,QXF,QXQ,QXS,QXW2,QZ RAC,REX4,RFR,RFR2,RHA,RNG,SAC,SAD2,SDB1,SDB3,SDN,SDS2,SDS3,SEE SHR4,SJC,SMB4,SSK2,STA,STP,SWX,SW2,SWB,TH,THU,T1,UH,UX,U1,VA VEB2,VED7,VH,VHQ4,VMB3,VS,VSDP,VSU,VS1,VTD,VTD1,VTE2,VTX,VTX1 VWA,VXE,VXE6,VXG,VXP,VXW,VXW1,VX26,V1
			1	1	-	-	8565637	BL,EMA2,HG12,HH,HHQ4,HH26,HX,HXE2,HXE8,HXU,HX2,HX26,HX4,KTA,NJ NJC1,NJG,SCJ,SD,SDS,SD16,SD4,SE,SG24,SH,SHM,SHQ4,SHRY,SJ,SJC1 SJC5,SJG,SKM,SMC7,SMC9,SMJ,SMJ1,SMW2,SMX4,SM11,SM12,SM14,SNX SNX1,SSK1,SSX2,ST,STM,STQ,SWG4,SX,SXE,SXE4,SXS4,SXU,SX4,SX7,S1 S1CY,VED,VED1,VED2,VED3,VED5,VED6,VSU,VSX1,VSX3,VS3,VS4 VXD,VXD1,WDA6,WJP,WKD6,WKT2,WKT4,WKT6,WMB0,WME2,WME4,WMT,W1
1	1	-	-	8566783	PHM,PX,PXU,QAB3,QAX2,QA2,QA26,QBT6,QCB2,QCL,QD,QE,QFE4,QGR2 QGR9,QH,QHE,QHP1,QHQ4,QH26,QI2,QKA4,QMC6,QMC8,QMD6,QME4,QMH QMX2,QMZ2,QNT,QNT4,QNZ,QP,QPU,QSC2,QSC9,QS2,QT,QVL,QWA4,QWX2 QX,QXC,QXC6,QXC9,QXE,QXE2,QXE4,QXE6,QXE8,QXF2,QXM1,QXS2,QXU QXW,QX2,QX22,QX26,QX4,QX7,Q1,TCS2,FX,TXC9,FXU,FX2,FX26,FX4,UXU VA2,VEBM,VGE4,VG24,VHH4,VMS4,VMS7,VPM4,VPM7,VPR4,VPR7,VSD,VSD1 VSD7,VS17,VTU1,VWA2,VW12,VX,VXE4,VXE7,VXM,VXU,VXU1,VXW2,VX2 VX4			
1	1	-	-	8571217	RD,RD4,RH,RHA2,RHQ4,RH2,RH26,RMB4,RMD,RMG2,RSK,RSS1,RTB2,RX RXE,RXE2,RXE4,RXU,RX4,R1,SWX2,SWX4			
1	-	-	-	8527259	QBC2,VEN2,VSG			
1	-	-	-	8574667	NSJ			
-	-	1	-					
-	-	-	1	2000281	SXP1			



E-6

CRANKCASE COVER(1)

G15

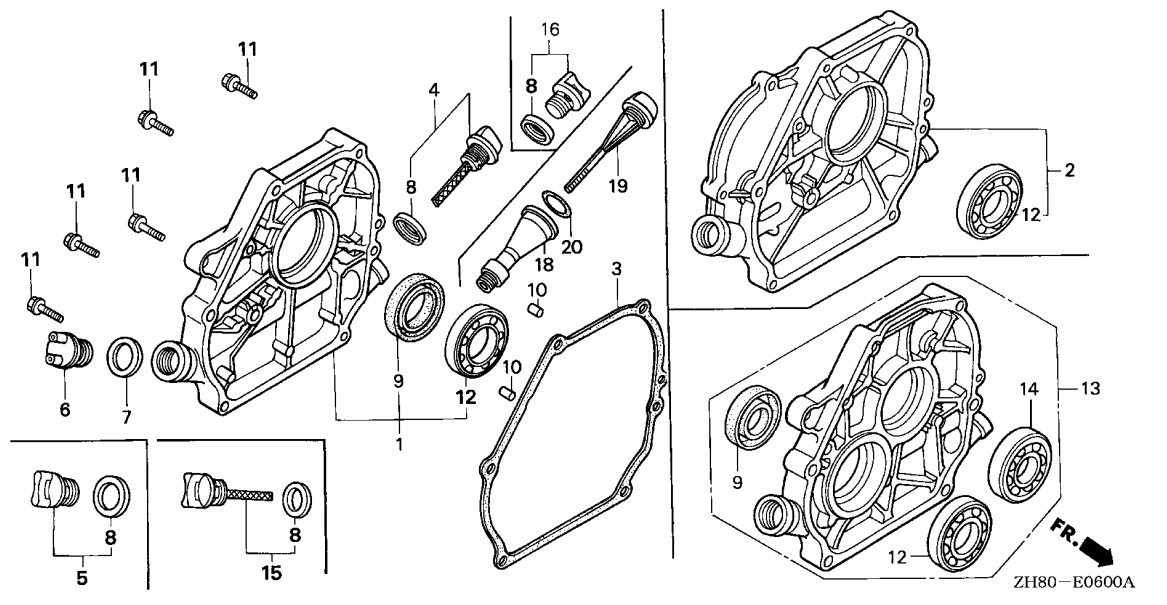

2

Ref. No.	Part No.	Description	Reqd. QTY				Serial No.	Parts catalogue code
			(1)	(2)	(3)	(4)		
(9)	91201-Z0T-801	OIL SEAL, 25X41X6	1	1	-	-	8565638	BL,EMA2,HG12,HH,HHQ4,HH26,HX,HXE2,HXE8,HXU,HX2,HX26,HX4,KTA,NJ,NJC1,NJG,SCJ,SD,SDS,SD16,SD4,SE,SG24,SH,SHM,SHQ4,SHRY,SJ,SJC1,SJC5,SJG,SKM,SMC7,SMC9,SMJ,SMJ1,SMW2,SMX4,SM11,SM12,SM14,SNX,SNX1,SSK1,SSX2,ST,STM,STQ,SWG4,SX,SXE,SXE4,SXS4,SXU,SX4,SX7,S1,S1CY,VED,VED1,VED2,VED3,VED5,VED6,VSB1,VSX,VX1,VX3,VX4,VXD,VXD1,WDA6,WJP,WKD6,WKT2,WKT4,WKT6,WMB0,WME2,WME4,WMT,W1,PHM,PX,PXU,QAB3,QAX2,QA2,QA26,QBT6,QCB2,QCL,QD,QE,QFE4,QGR2,QGR9,QH,QHE,QHP1,QHQ4,QH26,QI2,QKA4,QMC6,QMC8,QMD6,QME4,QMH,QMX2,QMZ2,QNT,QNT4,QNZ,QP,QPU,QSC2,QSC9,QS2,QT,QVL,QWA4,QWX2,QX,QXC,QXC6,QXC9,QXE,QXE2,QXE4,QXE6,QXE8,QXF2,QXM1,QXS2,QXU,QXW,QX2,QX22,QX26,QX4,QX7,Q1,TCS2,TX,TXC9,TXU,TX2,TX26,TX4,UXU,VA2,VEBM,VGE4,VG24,VHH4,VMS4,VMS7,VPM4,VPM7,VPR4,VPR7,VSD,VSD1,VSD7,VS17,VTU1,VWA2,VW12,VX,VXE4,VXE7,VXM,VXU,VXU1,VXW2,VX2,VX4
			1	1	-	-	8566784	RD,RD4,RH,RHA2,RHQ4,RH2,RH26,RMB4,RMD,RMG2,RSK,RSS1,RTB2,RX,RXE,RXE2,RXE4,RXU,RX4,R1,SWX2,SWX4
			1	-	-	-	8571218	VES,VHA7,VPM5
			1	-	-	-	8527260	QBC2,VEN2,VSG
			1	-	-	-	8574668	NSJ
			-	-	-	1	2000282	SXP1

Ref. No.	Part No.	Description	Reqd. QTY				Serial No.	Parts catalogue code
			(1)	(2)	(3)	(4)		
10	94301-08140	DOWEL PIN, 8X14	2	-	-	-	BL,DS,DSP,EMA,EMA2,EN,ET,ETX,HG1,HG12,HH,HHQ4,HH26,HX,HXE,HXE2,HXE8,HXQ,HXU,HX2,HX26,HX4,KTA,LAX,LAX2,LD,LDB1,LDB3,LDM,LD4,LHLHB3,LHQ4,LHW,LJ,LJC7,LJD,LJG,LJS,LMT,LSJ,LSJ4,LSS,LSS1,LSS4,LTA,LTk,LVL,LW2,LX,LXU,LX2,LX26,LX4,NJ,NJC1,NJG,NSJ,NW,PH,PHM,PHU,PM,PM2,PX,PXU,PX2,QA,QAB1,QAB3,QAX,QAX2,QA2,QA26,QBC2,QBT2,QBT6,QBU2,QCB2,QCL,QD,QE,QFE4,QGR2,QGR9,QH,QHE,QHP1,QHQ4,QH26,QI2,QKA4,QM,QMC6,QMC8,QMD6,QME4,QMH,QMX2,QMZ2,QNT,QNT2,QNT4,QNZ,QP,QPU,QSC2,QSC9,QS2,QT,QVL,QWA4,QWM2,QWX2,QWX3,QX,QXB,QXB1,QXC,QXC6,QXC9,QXE,QXE2,QXE4,QXE6,QXE8,QXF,QXF2,QXM1,QXQ,QXS,QXS2,QXU,QXW,QXW2,QX2,QX22,QX26,QX4,QX7,QZ,RAC,RD,RD4,REX4,RFR,RFR2,RH,RHA,RHA2,RHQ4,RH2,RH26,RMB4,RMD,RMG2,RNG,RSK,RSS1,RTB2,RX,RXE,RXE2,RXE4,RXU,RX4,SAC,SAD2,SCJ,SD,SDB1,SDB3,SDN,SDS,SDS2,SDS3,SD16,SD4,SE,SEE,SG24,SH,SHM,SHQ4,SHRY,SHR4,SJ,SJC,SJC1,SJC5,SJG,SKM,SMB4,SMC7,SMC9,SMJ,SMJ1,SMW2,SMX4,SM11,SM12,SM14,SNX,SNX1,SSK1,SSK2,SSX2,ST,STA,STM,STP,STQ,SWG4,SWX,SWX2,SWX4,SW2,SW,SXB,SXE,SXE4,SXS4,SXU,SX4,SX7,S1CY,TCS2,TH,THU,TX,TCX9,TXU,TX2,TX26,TX4,UH,UX,UXU,VA,VA2,VEBM,VEB2,VED,VED1,VED2,VED3,VED5,VED6,VED7,VEN2,VES,VGE4,VG24,VH,VHA7,VHH4,VHQ4,VMB3,VMS4,VMS7,VPM4,VPM5,VPM7,VPR4,VPR7,VS,VS1,VSD,VSD1,VSD7,VSG,VSW,VSX,VSX1,VSX3,VS1,VS17,VS3,VS4,VTD,VTD1,VTE2,VTU1,VTX,VTX1,VWA,VWA2,VW12,VX,VXD,VXD1,VXE,VXE4,VXE6,VXE7,VXG,VXM,VXU,VXU1,VXW,VXW1,VXW2,VX2,VX26,VX4,WDA6,WJP,WKD6,WKT2,WKT4,WKT6,WMB0,WME2,WME4,WMT	
			-	2	2	2		
11	95701-08032-00	BOLT, FLANGE, 8X32	6	-	-	-	BL,DS,DSP,EMA,EMA2,EN,ET,ETX,HG1,HG12,HH,HHQ4,HH26,HX,HXE,HXE2,HXE8,HXQ,HXU,HX2,HX26,HX4,KTA,LAX,LAX2,LD,LDB1,LDB3,LDM,LD4,LHLHB3,LHQ4,LHW,LJ,LJC7,LJD,LJG,LJS,LMT,LSJ,LSJ4,LSS,LSS1,LSS4,LTA,LTk,LVL,LW2,LX,LXU,LX2,LX26,LX4,NJ,NJC1,NJG,NSJ,NW,PH,PHM,PHU,PM,PM2,PX,PXU,PX2,QA,QAB1,QAB3,QAX,QAX2,QA2,QA26,QBC2,QBT2,QBT6,QBU2,QCB2,QCL,QD,QE,QFE4,QGR2,QGR9,QH,QHE,QHP1,QHQ4,QH26,QI2,QKA4,QM,QMC6,QMC8,QMD6,QME4,QMH,QMX2,QMZ2,QNT,QNT2,QNT4,QNZ,QP,QPU,QSC2,QSC9,QS2,QT,QVL,QWA4,QWM2,QWX2,QWX3,QX,QXB,QXB1,QXC,QXC6,QXC9,QXE,QXE2,QXE4,QXE6,QXE8,QXF,QXF2,QXM1,QXQ,QXS,QXS2,QXU,QXW,QXW2,QX2,QX22,QX26,QX4,QX7,QZ,RAC,RD,RD4,REX4,RFR,RFR2,RH,RHA,RHA2,RHQ4,RH2,RH26,RMB4,RMD,RMG2,RNG,RSK,RSS1,RTB2,RX,RXE,RXE2,RXE4,RXU,RX4,SAC,SAD2,SCJ,SD,SDB1,SDB3,SDN,SDS,SDS2,SDS3,SD16,SD4,SE,SEE,SG24,SH,SHM,SHQ4,SHRY,SHR4,SJ,SJC,SJC1,SJC5,SJG,SKM,SMB4,SMC7,SMC9,SMJ,SMJ1,SMW2,SMX4,SM11,SM12,SM14,SNX,SNX1,SSK1,SSK2,SSX2,ST,STA,STM,STP,STQ,SWG4,SWX,SWX2,SWX4,SW2,SW,SXB,SXE,SXE4,SXS4,SXU,SX4,SX7,S1CY,TCS2,TH,THU,TX,TCX9,TXU,TX2,TX26,TX4,UH,UX,UXU,VA,VA2,VEBM,VEB2,VED,VED1,VED2,VED3,VED5,VED6,VED7,VEN2,VES,VGE4,VG24,VH,VHA7,VHH4,VHQ4,VMB3,VMS4,VMS7,VPM4,VPM5,VPM7,VPR4,VPR7,VS,VS1,VSD,VSD1,VSD7,VSG,VSW,VSX,VSX1,VSX3,VS1,VS17,VS3,VS4,VTD,VTD1,VTE2,VTU1,VTX,VTX1,VWA,VWA2,VW12,VX,VXD,VXD1,VXE,VXE4,VXE6,VXE7,VXG,VXM,VXU,VXU1,VXW,VXW1,VXW2,VX2,VX26,VX4,WDA6,WJP,WKD6,WKT2,WKT4,WKT6,WMB0,WME2,WME4,WMT	
			-	6	6	6		



E-6

CRANKCASE COVER(1)

H 1

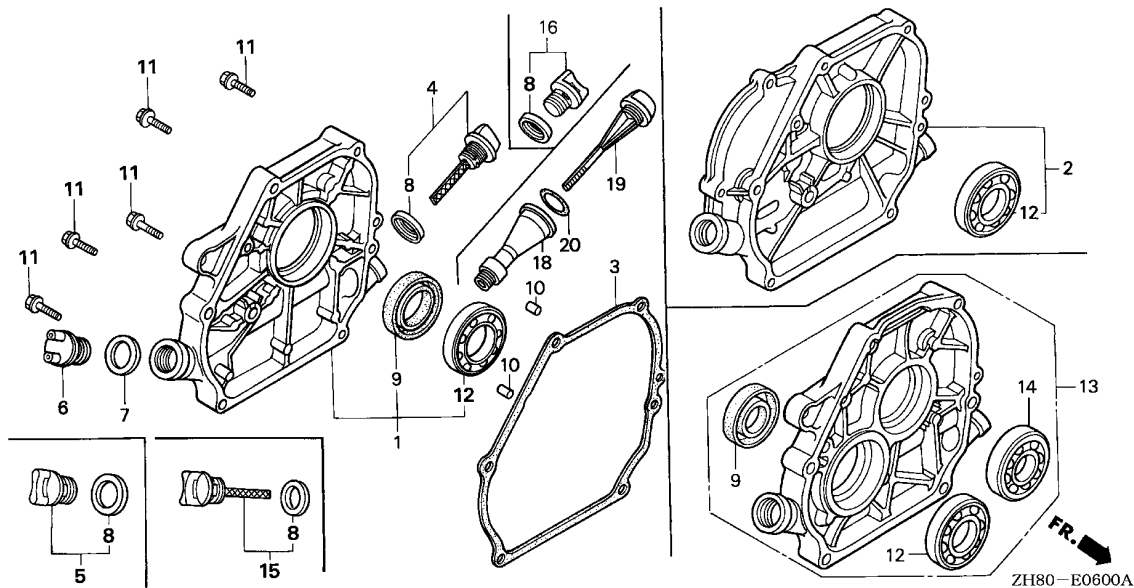

Ref. No.	Part No.	Description	Reqd. QTY				Serial No.	Parts catalogue code
			(1)	(2)	(3)	(4)		
			GX160K1					
			(1)	(2)	(3)	(4)		
12	96100-62050-00	BEARING, RADIAL BALL, 6205 ..	1	-	-	-	-----	BL,DS,DSP,EMA,EMA2,EN,ET,ETX,HG1,HG12,HH,HHQ4,HH26,HX,HXE,HXE2,HXE8,HXQ,HXU,HX2,HX26,HX4,KTA,LAX,LAX2,LD,LDB1,LDB3,LDM,LD4,LHLHB3,LHQ4,LHW,LJ,LJC7,LJD,LJG,LJS,LMT,LSJ,LSJ4,LSS,LSS1,LSS4,LTA,LTK,LVL,LW2,LX,LXU,LX2,LX26,LX4,NJ,NJC1,NJG,NSJ,NW,PH,PHM,PHU,PM,PM2,PX,PXU,PX2,QA,QAB1,QAB3,QAX,QAX2,QA2,QA26,QBC2,QBT2,QBT6,QBU2,QCB2,QCL,QD,QE,QFE4,QGR2,QGR9,QH,QHE,QHP1,QHQ4,QH26,QI2,QKA4,QM,QMC6,QMC8,QMD6,QME4,QMH,QMX2,QMZ2,QNT,QNT2,QNT4,QNZ,QP,QPU,QSC2,QSC9,QS2,QT,QVL,QWA4,QWM2,QWX2,QWX3,QX,QXB,QXB1,QXC,QXC6,QXC9,QXE,QXE2,QXE4,QXE6,QXE8,QXF,QXF2,QXM1,QXQ,QXS,QXS2,QXU,QXW,QXW2,QX2,QX22,QX26,QX4,QX7,QZ,RAC,RD,RD4,REX4,RFR,RFR2,RH,RHA,RHA2,RHQ4,RH2,RH26,RMB4,RMD,RMG2,RNG,RSK,RSS1,RTB2,RX,RXE,RXE2,RXE4,RXU,RX4,SAC,SAD2,SCJ,SD,SDB1,SDB3,SDN,SDS,SDS2,SDS3,SD16,SD4,SE,SEE,SG24,SH,SHM,SHQ4,SHRY,SHR4,SJSJC,SJC1,SJC5,SJG,SKM,SMB4,SMC7,SMC9,SMJ,SMJ1,SMW2,SMX4,SM11,SM12,SM14,SNX,SNX1,SSK1,SSK2,SSX2,ST,STA,STM,STP,STQ,SWG4,SWX,SWX2,SWX4,SW2,SX,SXB,SXE,SXE4,SXS4,SXU,SX4,SX7,S1CY,TCS2,TH,THU,TX,TC9,TXU,TX2,TX26,TX4,UH,UX,UXU,VA,VA2,VEBM,VEB2,VED,VED1,VED2,VED3,VED5,VED6,VED7,VEN2,VES,VGE4,VG24,VH,VHA7,VHH4,VHQ4,VMB3,VMS4,VMS7,VPM4,VPM5,VPM7,VPR4,VPR7,VS,VSB1,VSD,VSD1,VSD7,VSG,VSU,VSX,VSX1,VSX3,VS1,VS17,VS3,VS4,VD,VD1,VTE2,VTU1,VTX,VTX1,VWA,VWA2,VW12,VX,VXD,VXD1,VXE,VXE4,VXE6,VXE7,VXG,VXM,VXU,VXU1,VXW,VXW1,VXW2,VX2,VX26,VX4,WDA6,WJP,WKD6,WKT2,WKT4,WKT6,WMB0,WME2,WME4,WMT
			-	1	1	1		
13	11300-ZL0-690	COVER ASSY., CRANKCASE	1	-	-	-	-----	NW
			1	-	-	-	-----	8565637 NJ,NJC1,NJG
	11300-ZL0-691	1	-	-	-	-----	NSJ
			1	-	-	-	-----	8565638 NJ,NJC1,NJG

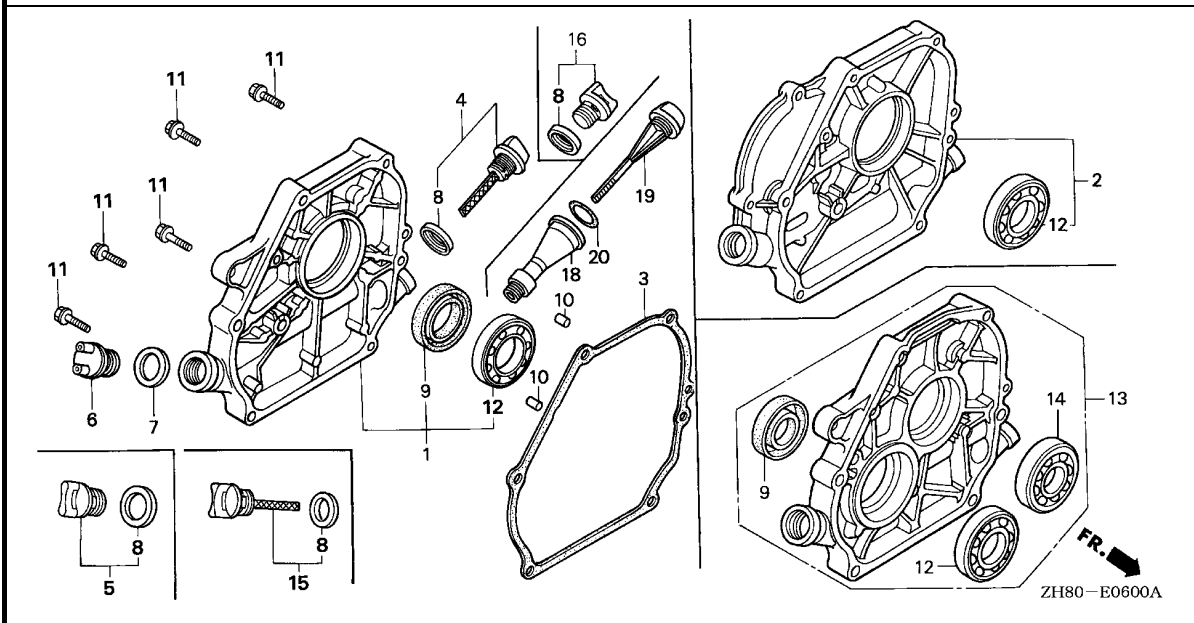

Ref. No.	Part No.	Description	Reqd. QTY				Serial No.	Parts catalogue code
			(1)	(2)	(3)	(4)		
				GX160K1				
14	91001-GF6-004	BEARING, RADIAL BALL, 6304 ..	1	-	-	-	----- NJ,NJC1,NJG,NSJ,NW	
15	15600-ZE1-003	CAP ASSY., OIL FILLER (GRAY)	1	-	-	-----	----- SWX2,SWX4	
			1	-	-	2899522	----- SMJ1	
16	15600-ZG4-003	CAP ASSY., OIL FILLER	1	-	-	-----	----- SWX2,SWX4	
18	15640-730-010	PIPE, OIL FILLER	1	-	-	-----	----- RFR,RFR2,SKM	
19	15650-730-000	GAUGE, OIL LEVEL	1	-	-	-----	----- RFR,RFR2,SKM	
20	94608-50000	O-RING, 23X2.8	1	-	-	-----	----- RFR,RFR2,SKM	



E-6-1

CRANKCASE COVER(2)

H 3

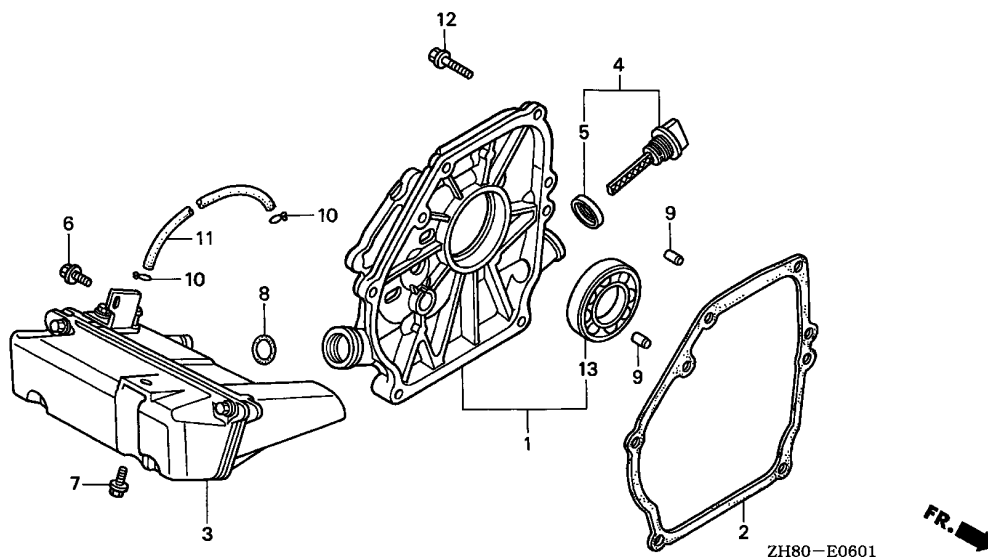

Ref. No.	L.O.N.	(Relative ref. Number) Description	F.R.T.
1	1101G0	COVER, CRANKCASE(A)	0.6
2	1101F9	PACKING, CASE COVER(A)	0.6
3	1171A3	TANK, OIL	0.2
13	1101G4	BEARING, CRANKSHAFT(A) :REAR ..	0.7

Ref. No.	Part No.	Description	Reqd. QTY				Serial No.	Parts catalogue code
			(1)	(2)	(3)	(4)		
			GX160K1					
1	11300-ZK8-V00	COVER ASSY., CRANKCASE	1	-	-	-	AR,ARC6,KR	
2	11381-ZK8-V00	PACKING, CASE COVER	1	-	-	-	AR,ARC6,KR	
3	15500-ZK8-V00	TANK ASSY., OIL	1	-	-	-	AR,ARC6,KR	
4	15600-ZE1-003	CAP ASSY., OIL FILLER (GRAY) ..	1	-	-	-	AR,ARC6,KR	
5	15625-ZE1-003	PACKING, OIL FILLER CAP	1	-	-	-	AR,ARC6,KR	
6	90014-952-000	BOLT, FLANGE, 6X14(CT200) ...	1	-	-	-	AR,ARC6,KR	
7	90029-888-000	BOLT, FLANGE, 6X16(CT200) ...	1	-	-	-	AR,ARC6,KR	
8	91304-MJ0-003	O-RING, 15.8X2.4(SHOWA)	1	-	-	-	AR,ARC6,KR	
9	94303-08140	DOWEL PIN, 8X14	2	-	-	-	AR,ARC6,KR	
10	95002-02070	CLIP, TUBE (B7)	2	-	-	-	AR,ARC6,KR	
11	95005-35130-10	TUBE, 3.5X130(95005-35001-10M)	1	-	-	-	AR,ARC6,KR	
12	95701-08032-00	BOLT, FLANGE, 8X32	6	-	-	-	AR,ARC6,KR	
13	96100-62050-00	BEARING, RADIAL BALL, 6205 ..	1	-	-	-	AR,ARC6,KR	

2

E-6-2

CRANKCASE COVER(3)

H 4

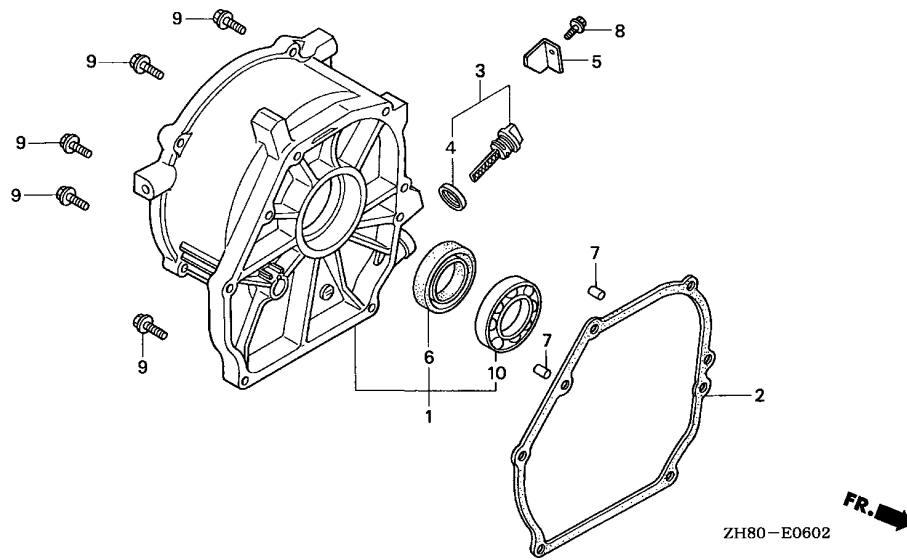

Ref. No.	L.O.N.	(Relative ref. Number) Description	F.R.T.
1	1101F1	COVER, CRANKCASE	0.2
2	1101E9	PACKING, CASE COVER	0.2
6	1101E5	OIL SEAL, CRANKSHAFT :REAR ...	0.3
10	1101A6	BEARING, CRANKSHAFT :REAR	0.4

Ref. No.	Part No.	Description	Reqd. QTY				Serial No.	Parts catalogue code
			(1)	(2)	(3)	(4)		
1	11300-ZH8-F00	COVER ASSY., CRANKCASE	1	-	-	-	8565637	VMT
	11300-ZH8-F01	1	-	-	-	8565638	VMT
2	11381-ZH8-801	PACKING, CASE COVER (NON ASBEST)	1	-	-	-	-----	VMT
3	15600-ZE1-003	CAP ASSY., OIL FILLER (GRAY)	1	-	-	-	-----	VMT
4	15625-ZE1-003	PACKING, OIL FILLER CAP	1	-	-	-	-----	VMT
5	50339-ZR4-T60	PLATE, GUARD	1	-	-	-	-----	VMT
6	91202-883-005	OIL SEAL, 25X41X6	1	-	-	-	8565637	VMT
	91201-Z0T-801	1	-	-	-	8565638	VMT
7	94301-08140	DOWEL PIN, 8X14	2	-	-	-	-----	VMT
8	95701-06012-00	BOLT, FLANGE, 6X12	1	-	-	-	-----	VMT
9	95701-08032-00	BOLT, FLANGE, 8X32	6	-	-	-	-----	VMT
10	96100-62050-00	BEARING, RADIAL BALL, 6205 ..	1	-	-	-	-----	VMT

2

E-7

CRANKSHAFT(1)

H 5

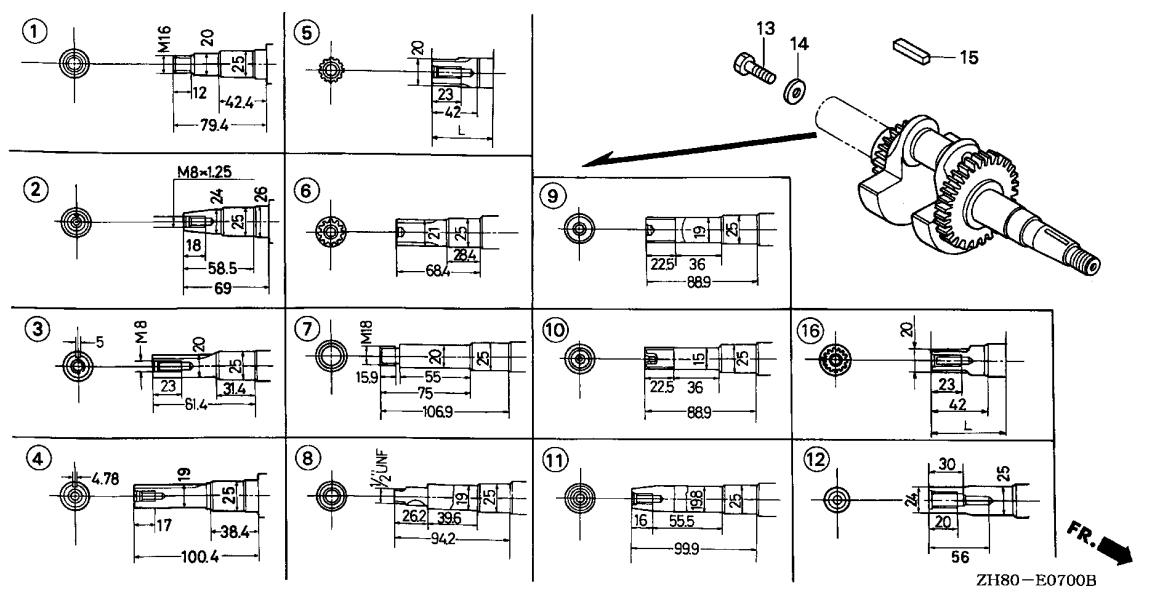

Ref. No.	L.O.N.	(Relative ref. Number) Description	F.R.T.
1	1101F0	(2,3,4,5,6,7,8,9,10,11,12,16) CRANKSHAFT	1.1

Ref. No.	Part No.	Description	Reqd. QTY				Serial No.	Parts catalogue code
			(1)	(2)	(3)	(4)		
1	13310-YB4-010	CRANKSHAFT COMP.	1	-	1	-	WIH1,WJP,WME2,WME4	
2	13310-ZB2-000	CRANKSHAFT COMP.	1	-	-	-	BL,EMA,EMA2,EN,ET,ETX,VEBM,VEB2,VED,VED1,VED2,VED3,VED5,VED6,VED7,VEN2,VES,VG24,VMT,VTE2,VXD,VXD1	
3	13310-ZE1-000	CRANKSHAFT COMP. (24T)	1	1	-	1	RAC,RD,RD4,REX4,RFR,RFR2,RH,RHA,RHA2,RHQ4,RH2,RH26,RMB4,RMD,RMG2,RNG,RSK,RSS1,RTB2,RX,RXE,RXE2,RXE4,RXU,RX4,R1,SAC,SAD2,SCJ,SD,SDB1,SDB3,SDN,SDS,SDS2,SDS3,SD16,SD4,SE,SEE,SG24,SH,SHM,SHQ4,SHRY,SHR4,SJ,SJC,SJC1,SJC5,SJG,SKM,SMB4,SMC7,SMC9,SMJ,SMJ1,SMW2,SMX4,SM11,SM12,SM14,SNX,SNX1,SSK1,SSK2,SSX2,ST,STA,STM,STP,STQ,SWG4,SWX,SWX2,SWX4,SW2,SX,SXB,SXE,SXE4,SXP1,SXS4,SXU,SX4,S1,S1CY	
	13310-Z8K-000	CRANKSHAFT COMP. (18T)	1	-	-	-	SX7	
4	13310-ZE1-601	CRANKSHAFT COMP. (24T)	1	1	1	-	QA,QAB1,QAB3,QAX,QAX2,QA2,QA26,QBC2,QBT2,QBT6,QBU2,QCB2,QCL,QD,QE,QFE4,QGR2,QGR9,QH,QHE,QHP1,QHQ4,QH26,QIH1,QI2,QKA4,QM,QMC6,QMC8,QMD6,QME4,QMH,QMX2,QMZ2,QNT,QNT2,QNT4,QNZ,QP,QPU,QSC2,QSC9,QS2,QT,QVL,QWA4,QWM2,QWX2,QWX3,QX,QXB,QXB1,QXC,QXC6,QXC9,QXE,QXE2,QXE4,QXE6,QXE8,QXF,QXF2,QXM1,QXQ,QXS,QXS2,QXU,QXW,QXW2,QX2,QX22,QX26,QX4,QZ,Q1	
	13310-Z8K-600	CRANKSHAFT COMP. (18T)	1	-	-	-	QX7	
5	13310-ZE1-610	CRANKSHAFT COMP. (L=248.9) ..	1	1	-	-	DS,DSP,LAX,LAX2,LD,LDB1,LDB3,LDM,LD4,LH,LHB3,LHQ4,LHW,LJ,LJC7,LJD,LJG,LJS,LMT,LSJ,LSJ4,LSS,LSS1,LSS4,LTA,LTk,LVL,LW2,LX,LXU,LX2,LX26,LX4,L1	
6	13310-ZE1-622	CRANKSHAFT COMP.	1	1	-	-	HG1,HG12,HH,HHQ4,HH26,HX,HXE,HXE2,HXE8,HXQ,HXU,HX2,HX26,HX4,H1	
7	13310-ZE1-630	CRANKSHAFT COMP.	1	1	-	-	WDA6,WKD6,WKT2,WKT4,WKT6,WMB0,WMT,W1	
8	13310-ZE1-641	CRANKSHAFT COMP.	1	1	1	-	UH,UIH,UX,UXU,U1	
9	13310-ZE1-650	CRANKSHAFT COMP.	1	-	-	-	PH,PHM,PHU,PM,PM2,PX,PXU,PX2	
10	13310-ZE1-660	CRANKSHAFT COMP.	1	1	-	-	TCS2,TH,THU,TX,TCX9,TXU,TX2,TX26,TX4,T1	

2

Ref. No.	Part No.	Description	Reqd. QTY				Serial No.	Parts catalogue code
			GX160K1					
			(1)	(2)	(3)	(4)		
11	13310-ZE1-670	CRANKSHAFT COMP. (24T)	1	1	1	1	VA,VA2,VGE4,VH,VHH4,VHQ4,VIH1,VMB3,VMS4,VPM4,VPM5,VPR4,VS,VSB1 VSD,VSDP,VSD1,VSG,VSW,VSX,VSX1,VSX3,VS1,VS3,VS4,VTD,VTD1,VTU1 VTX,VTX1,VWA,VWA2,VW12,VX,VXE,VXE4,VXE6,VXG,VXM,VXP,VXU,VXU1 VXW,VXW1,VXW2,VX2,VX26,VX4,V1	
	13310-Z8K-670	CRANKSHAFT COMP. (18T)	1	-	-	-	VHA7,VMS7,VPM7,VPR7,VSD7,VS17,VXE7	
12	13310-ZH8-R00	CRANKSHAFT COMP.	1	-	-	-	KTA	
13	90003-ZE1-000	BOLT, HEX., 5/16"	1	(1)	1	-	QIH1,QT,QVL,QZ,Q1	
			1	-	-	-	6649705 QAB3	
			1	-	-	-	6745959 QMX2	
	92000-08025-0A	BOLT, HEX., 8X25	1	(1)	-	-	LTA,L1,RMD,RSS1,R1,SCJ,SJ,ST,STA,STP,STQ,S1	
	92101-08025-0A	1	-	-	-	LHW,LJC7,LJD,LSJ,LSS1,LTK,LVL,RNG,SHRY,SHR4,SJC,SJC1,SJC5,SJG SMJ,SMJ1,SMW2,SMX4,SM11,SM14,SSK1,SSK2,SSX2,S1CY	
			1	-	-	-	6649705 LHB3	
14	90473-842-000	WASHER, 8MM	1	(1)	1	-	LHW,LJC7,LJD,LSJ,LSJ4,LSS1,LSS4,LTA,LTK,LVL,L1,QIH1,QT,QVL,QZ Q1,RMD,RNG,RSS1,R1,SCJ,SHRY,SHR4,SJ,SJC,SJC1,SJC5,SJG,SMJ,SMJ1 SMW2,SMX4,SM11,SM14,SSK1,SSK2,SSX2,ST,STA,STP,STQ,S1,S1CY	
			1	-	-	-	6649705 LHB3,QAB3	
			1	-	-	-	6745959 QMX2	
15	90741-883-810	KEY, 5X5X33(YELLOW)	1	(1)	-	-	LJC7,LJD,LTK,RD,RD4,RMD,RNG,RSS1,SAD2,SCJ,SD,SDB1,SDB3,SDN,SDS SDS2,SDS3,SD16,SD4,SE,SEE,SG24,SH,SHM,SHQ4,SHRY,SHR4,SJ,SJC SJC1,SJC5,SJG,SKM,SMC7,SMC9,SMJ,SMJ1,SMW2,SMX4,SM11,SM12,SM14 SSK1,SSK2,SSX2,ST,STA,STP,STQ,SWG4,SWX,SWX2,SWX4,SW2,SX,AXB SXE,SXE4,SXS4,SXU,SX4,SX7,S1,S1CY	
	90745-ZE1-600	KEY, 4.78X4.78X38	1	(1)	1	-	QA,QAB1,QAB3,QAX,QAX2,QA2,QA26,QBC2,QBT2,QBT6,QBU2,QCB2,QCL,QD QE,QFE4,QGR2,QGR9,QHP1,QIH1,QI2,QKA4,QMC6,QMC8,QMD6,QMH,QMX2 QMZ2,QNT2,QNT4,QPU,QSC2,QSC9,QS2,QT,QVL,QWA4,QWM2,QWX2,QWX3,QX QXB,QXB1,QXC,QXC6,QXC9,QXE,QXE2,QXE4,QXE6,QXE8,QXF,QXF2,QXM1 QXQ,QXS,QXS2,QXU,QXW,QXW2,QX2,QX22,QX26,QX4,QX7,QZ,Q1	
			1	-	-	-	2389562 QNT	
16	13310-ZK8-V00	CRANKSHAFT COMP. (L=235.9) ..	1	-	-	-	AR,ARC6,KR	



E-7-1

CRANKSHAFT(2)

H 7

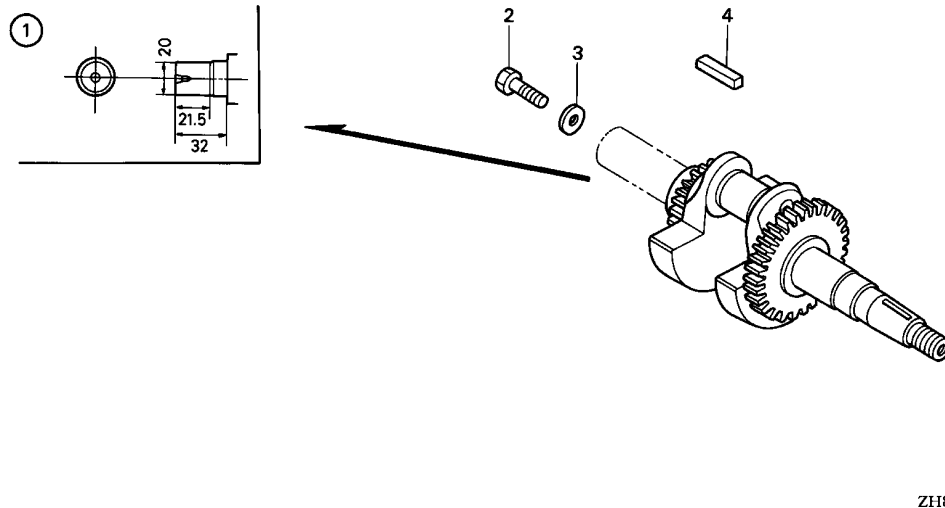

Ref. No.	L.O.N.	(Relative ref. Number) Description	F.R.T.
1	1101F0	CRANKSHAFT	1.1

2

Ref. No.	Part No.	Description	Reqd. QTY				Serial No.	Parts catalogue code
			(1)	(2)	(3)	(4)		
				GX160K1				
1	13310-ZH8-690	CRANKSHAFT COMP.	1	-	-	-	NJ,NJC1,NJG,NSJ,NW	
2	92101-08025-0A	BOLT, HEX., 8X25	1	-	-	-	NSJ,NW	
3	90473-842-000	WASHER, 8MM	1	-	-	-	NSJ,NW	
4	90741-883-810	KEY, 5X5X33(YELLOW)	1	-	-	-	NJ,NJC1,NSJ,NW	

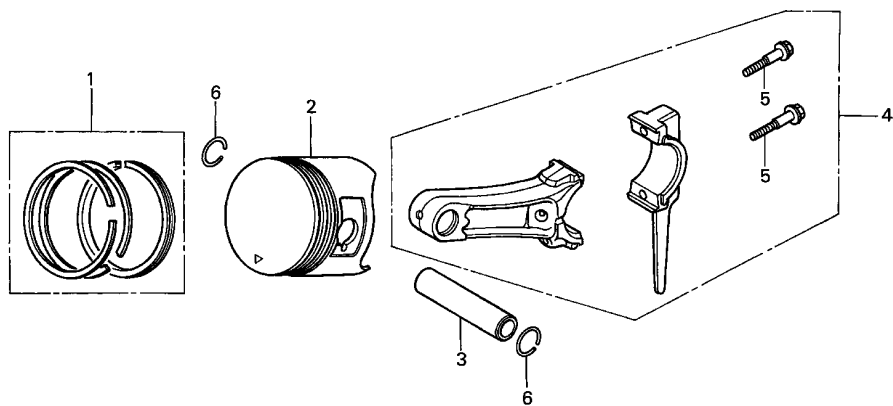

ZH80-E0800

Ref. No.	L.O.N.	(Relative ref. Number) Description	F.R.T.
4	(1,2,3)		
1101F3		ROD, CONNECTING AND/OR PIN, PISTON	1.0
1101F3A		.Replace 1 piston and/or ring, piston add	0.1

Ref. No.	Part No.	Description	Reqd. QTY				Serial No.	Parts catalogue code
			(1)	(2)	(3)	(4)		
1	13010-ZF1-023	RING SET, PISTON (STD.) (TEIKOKU)	1	-	1	-	-----	EMA,EMA2,EN,ET,ETX,HG1,HXQ,LAX,LAX2,LJD,LSS1,LTA,LTK,PM,QAX,QBU2,QNT2,QXB,QXF,QXS,QZ,RAC,RFR,RHA,SAC,SAD2,SMB4,SSK2,STASWX,SW2,UIH,VA,VEB2,VHQ4,VSW,VS1,VTE2,VWA,VXE,VXW,VXW1
			1	-	-	-	4733210	PHU,RD,RD4,RH,RHQ4,RH2,RSK,RXE4,RX4,SMJ,SMJ1,THU,TX2,VEBM,VED,VED1,VED2,VED3,VH,VHH4,VMS4,VS,VSX,VSX1,VS3,VS4,VX,VXE4,VXUVX2,VX26,VX4,WKT2,WMB0
			1	-	-	-	4764118	SWG4
			1	-	-	-	5495899	AR,ARC6,DS,DSP,HG12,HH,HHQ4,HH26,HX,HXE,HX2,HX26,HX4,KR,KTA,LD,LDB1,LDB3,LDM,LD4,LH,LHB3,LHQ4,LJ,LJC7,LJG,LJS,LMT,LSJ,LSJ4,LSS,LSS4,LW2,LX,LX2,LX26,LX4,NJ,NJG,NSJ,NW,PH,PHM,PM2,PX,PX2,QA,QAB1,QAB3,QAX2,QA2,QA26,QBT2,QBT6,QD,QE,QFE4,QGR2,QH,QHE,QHP1,QHQ4,QH26,QKA4,QM,QMC6,QMC8,QMD6,QME4,QMH,QMX2,QMZ2,QNT,QNT4,QNZ,QP,QPU,QSC2,QT,QWM2,QWX2,QX,QXB1,QXC,QXC6,QXC9,QXE,QXE2,QXE4,QXE6,QXF2,QXM1,QXQ,QXS2,QXW,QXW2,QX2,QX26,QX4,REX4,RFR2,RHA2,RH26,RMB4,RMD,RMG2,RNG,RTB2,RX,RXE,SCJ,SD,SDB1,SDB3,SDN,SDS,SDS2,SDS3,SD16,SD4,SE,SEE,SG24,SH,SHM,SHQ4,SJ,SJC,SJC1,SJC5,SJG,SKM,SMC7,SMC9,SMW2,SSK1,SSX2,ST,STP,STQ,SX,SBX,SXE,SXE4,SX4,TH,TX,TCX9,TX26,TX4,UH,UX,VA2,VED5,VW12,VXD,VXD1,VXE6,VXG,VXM,WJP
			-	1	-	-	5495899	
			-	-	-	1	2000029	VSDP,VXP



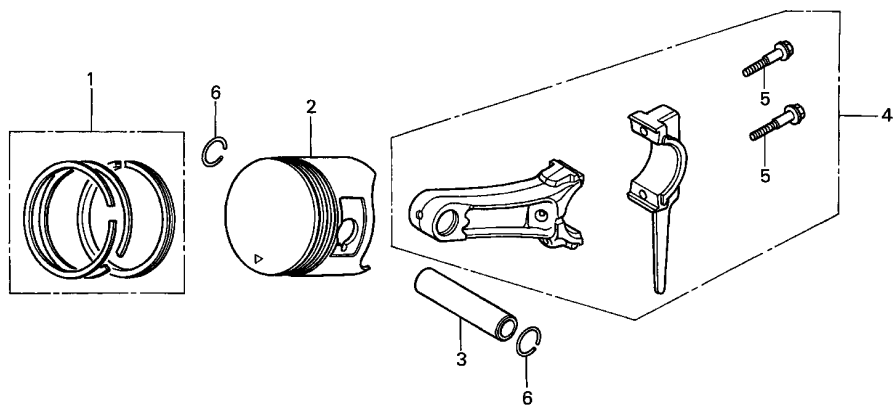

ZH80-E0800



2

Ref. No.	Part No.	Description	Reqd. QTY				Serial No.	Parts catalogue code
			(1)	(2)	(3)	(4)		
(1)	13010-ZF1-024	RING SET, PISTON (STD.) (NIPPON)	1	-	1	-	-----	EMA,EMA2,EN,ET,ETX,HG1,HXQ,LAX,LAX2,LJD,LSS1,LTA,LTK,PM,QAX,QBU2,QNT2,QXB,QXF,QXS,QZ,RAC,RFR,RHA,SAC,SAD2,SMB4,SSK2,STASWX,SW2,UIH,VA,VEB2,VHQ4,VSD,VSW,VS1,VTE2,VVA,VXE,VXW,VXW1
			1	-	-	-	4733210	PHU,RD,RD4,RH,RHQ4,RH2,RSK,RXE4,RX4,SMJ,SMJ1,THU,TX2,VEBM,VED,VED1,VED2,VED3,VH,VHH4,VMS4,VS,VSX,VSX1,VS3,VS4,VX,VXE4,VXUVX2,VX26,VX4,WKT2,WMB0
			1	-	-	-	4764118	SWG4
			1	-	-	-	5495899	AR,ARC6,DS,DSP,HG12,HH,HHQ4,HH26,HX,HXE,HX2,HX26,HX4,KR,KTA,LD,LDB1,LDB3,LDM,LD4,LH,LHB3,LHQ4,LJ,LJC7,LJG,LJS,LMT,LSJ,LSJ4,LSS,LSS4,LW2,LX,LX2,LX26,LX4,NJ,NJG,NSJ,NW,PH,PHM,PM2,PX,PX2,QA,QAB1,QAB3,QAX2,QA2,QA26,QBT2,QBT6,QD,QE,QFE4,QGR2,QH,QHE,QHP1,QHQ4,QH26,QKA4,QM,QMC6,QMC8,QMD6,QME4,QMH,QMX2,QMZ2,QNT,QNT4,QNZ,QP,QPU,QSC2,QT,QWM2,QWX2,QX,QXB1,QXC,QXC6,QXC9,QXE,QXE2,QXE4,QXE6,QXF2,QXM1,QXQ,QXS2,QXW,QXW2,QX2,QX26,QX4,REX4,RFR2,RHA2,RH26,RMB4,RMD,RMG2,RNG,RTB2,RX,RXE,SCJ,SD,SDB1,SDB3,SDN,SDS,SDS2,SDS3,SD16,SD4,SE,SEE,SG24,SH,SHM,SHQ4,SJ,SJC,SJC1,SJC5,SJG,SKM,SMC7,SMC9,SMW2,SSK1,SSX2,ST,STP,STQ, SX, SXB, SXE, SXE4, SX4, TH, TX, TXC9, TX26, TX4, UH, UX, VA2, VED5, VW12, VXD, VXD1, VXE6, VXG, VXW, WJP
			-	1	-	-	5495899	
			-	-	-	1	2000029	VSDP,VXP

Ref. No.	Part No.	Description	Reqd. QTY				Serial No.	Parts catalogue code
			GX160K1					
			(1)	(2)	(3)	(4)		
(1)	13011-ZF1-023	RING SET, PISTON (0.25) (TEIKOKU)	(1)	-	(1)	-	-----	EMA,EMA2,EN,ET,ETX,HG1,HXQ,LAX,LAX2,LJD,LSS1,LTA,LTK,PM,QAX QBU2,QNT2,QXB,QXF,QXS,QZ,RAC,RFR,RHA,SAC,SAD2,SMB4,SSK2,STA SWX,SW2,UIH,VA,VEB2,VHQ4,VSW,VS1,VTE2,VWA,VXE,VXW,VXW1
			(1)	-	-	-	-----	4733210 PHU,RD,RD4,RH,RHQ4,RH2,RSK,RXE4,RX4,SMJ,SMJ1,THU,TX2,VEBM,VED VED1,VED2,VED3,VH,VHH4,VMS4,VS,VSX,VSX1,VS3,VS4,VX,VXE4,VXU VX2,VX26,VX4,WKT2,WMB0
			(1)	-	-	-	-----	4764118 SWG4
			(1)	-	-	-	-----	5495899 AR,ARC6,DS,DSP,HG12,HH,HHQ4,HH26,HX,HXE,HX2,HX26,HX4,KR,KTA,LD LDB1,LDB3,LDM,LD4,LH,LHB3,LHQ4,LJ,LJC7,LJG,LJS,LMT,LSJ,LSJ4 LSS,LSS4,LW2,LX,LX2,LX26,LX4,NJ,NJG,NSJ,NW,PH,PHM,PM2,PX,FX2 QA,QAB1,QAB3,QAX2,QA2,QA26,QBT2,QBT6,QD,QE,QFE4,QGR2,QH,QHE QHP1,QHQ4,QH26,QKA4,QM,QMC6,QMC8,QMD6,QME4,QMH,QMX2,QMZ2,QNT QNT4,QNZ,QP,QPU,QSC2,QT,QWM2,QWX2,QX,QXB1,QXC,QXC6,QXC9,QXE QXE2,QXE4,QXE6,QXF2,QXM1,QXQ,QXS2,QXW,QXW2,QX2,QX26,QX4,REX4 RFR2,RHA2,RH26,RMB4,RMD,RMG2,RNG,RTB2,RX,RXE,SCJ,SD,SDB1,SDB3 SDN,SDS,SDS2,SDS3,SD16,SD4,SE,SEE,SG24,SH,SHM,SHQ4,SJ,SJC,SJC1 SJC5,SJG,SKM,SMC7,SMC9,SMW2,SSK1,SSX2,ST,STP,STQ,SX,SBX,SXE SXE4,SX4,TH,TX,TXC9,TX26,TX4,UH,UX,VA2,VED5,VW12,VXD,VXD1,VXE6 VXG,VXM,WJP
			-	(1)	-	-	-----	5495899
			-	-	-	(1)	-----	2000029 VSDP,VXP
	13011-ZF1-024	RING SET, PISTON (0.25) (NIPPON)	(1)	-	(1)	-	-----	EMA,EMA2,EN,ET,ETX,HG1,HXQ,LAX,LAX2,LJD,LSS1,LTA,LTK,PM,QAX QBU2,QNT2,QXB,QXF,QXS,QZ,RAC,RFR,RHA,SAC,SAD2,SMB4,SSK2,STA SWX,SW2,UIH,VA,VEB2,VHQ4,VSW,VS1,VTE2,VWA,VXE,VXW,VXW1
			(1)	-	-	-	-----	4733210 PHU,RD,RD4,RH,RHQ4,RH2,RSK,RXE4,RX4,SMJ,SMJ1,THU,TX2,VEBM,VED VED1,VED2,VED3,VH,VHH4,VMS4,VS,VSX,VSX1,VS3,VS4,VX,VXE4,VXU VX2,VX26,VX4,WKT2,WMB0
			(1)	-	-	-	-----	4764118 SWG4
			(1)	-	-	-	-----	5495899 AR,ARC6,DS,DSP,HG12,HH,HHQ4,HH26,HX,HXE,HX2,HX26,HX4,KR,KTA,LD LDB1,LDB3,LDM,LD4,LH,LHB3,LHQ4,LJ,LJC7,LJG,LJS,LMT,LSJ,LSJ4 LSS,LSS4,LW2,LX,LX2,LX26,LX4,NJ,NJG,NSJ,NW,PH,PHM,PM2,PX,FX2 QA,QAB1,QAB3,QAX2,QA2,QA26,QBT2,QBT6,QD,QE,QFE4,QGR2,QH,QHE QHP1,QHQ4,QH26,QKA4,QM,QMC6,QMC8,QMD6,QME4,QMH,QMX2,QMZ2,QNT QNT4,QNZ,QP,QPU,QSC2,QT,QWM2,QWX2,QX,QXB1,QXC,QXC6,QXC9,QXE QXE2,QXE4,QXE6,QXF2,QXM1,QXQ,QXS2,QXW,QXW2,QX2,QX26,QX4,REX4 RFR2,RHA2,RH26,RMB4,RMD,RMG2,RNG,RTB2,RX,RXE,SCJ,SD,SDB1,SDB3 SDN,SDS,SDS2,SDS3,SD16,SD4,SE,SEE,SG24,SH,SHM,SHQ4,SJ,SJC,SJC1 SJC5,SJG,SKM,SMC7,SMC9,SMW2,SSK1,SSX2,ST,STP,STQ,SX,SBX,SXE SXE4,SX4,TH,TX,TXC9,TX26,TX4,UH,UX,VA2,VED5,VW12,VXD,VXD1,VXE6 VXG,VXM,WJP
			-	(1)	-	-	-----	5495899
			-	-	-	(1)	-----	2000029 VSDP,VXP



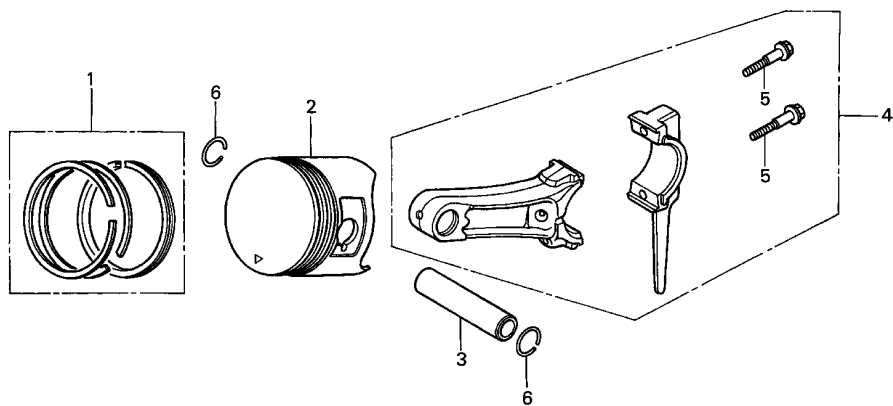

ZH80-E0800



Ref. No.	Part No.	Description	Reqd. QTY				Serial No.	Parts catalogue code
			(1)	(2)	(3)	(4)		
			GX160K1					
(1)	13012-ZF1-023	RING SET, PISTON (0.50)	(1)	-	(1)	-		
		(TEIKOKU)	(1)	-	(1)	-	EMA,EMA2,EN,ET,ETX,HG1,HXQ,LAX,LAX2,LJD,LSS1,LTA,LTK,PM,QAX,QBU2,QNT2,QXB,QXF,QXS,QZ,RAC,RFR,RHA,SAC,SAD2,SMB4,SSK2,STASWX,SW2,UIH,VA,VEB2,VHQ4,VSW,VS1,VTE2,VVA,VXE,VXW,VXW1	
			(1)	-	-	-	4733210 PHU,RD,RD4,RH,RHQ4,RH2,RSK,RXE4,RX4,SMJ,SMJ1,THU,TX2,VEBM,VED,VED1,VED2,VED3,VH,VHH4,VMS4,VS,VSX,VSX1,VS3,VS4,VX,VXE4,VXUVX2,VX26,VX4,WKT2,WMB0	
			(1)	-	-	-	4764118 SWG4	
			(1)	-	-	-	5495899 AR,ARC6,DS,DSP,HG12,HH,HHQ4,HH26,HX,HXE,HX2,HX26,HX4,KR,KTA,LD,LDB1,LDB3,LDM,LD4,LH,LHB3,LHQ4,LJ,LJC7,LJG,LJS,LMT,LSJ,LSJ4,LSS,LSS4,LW2,LX,LX2,LX26,LX4,NJ,NJG,NSJ,NW,PH,PHM,PM2,PX,PX2,QA,QAB1,QAB3,QAX2,QA2,QA26,QBT2,QBT6,QD,QE,QFE4,QGR2,QH,QHE,QHP1,QHQ4,QH26,QKA4,QM,QMC6,QMC8,QMD6,QME4,QMH,QMX2,QMZ2,QNT,QNT4,QNZ,QP,QPU,QSC2,QT,QWM2,QWX2,QX,QXB1,QXC,QXC6,QXC9,QXE,QXE2,QXE4,QXE6,QXF2,QXM1,QXQ,QXS2,QXW,QXW2,QX2,QX26,QX4,REX4,RFR2,RHA2,RH26,RMB4,RMD,RMG2,RNG,RTB2,RX,RXE,SCJ,SD,SDB1,SDB3,SDN,SDS,SDS2,SDS3,SD16,SD4,SE,SEE,SG24,SH,SHM,SHQ4,SJ,SJC,SJC1,SJC5,SJG,SKM,SMC7,SMC9,SMW2,SSK1,SSX2,ST,STP,STQ,SX,SBX,SXESXE4,SX4,TH,TX,TCX9,TX26,TX4,UH,UX,VA2,VED5,VW12,VXD,VXD1,VXE6VXG,VXM,WJP	
			-	(1)	-	-	5495899	
			-	-	-	(1)	2000029 VSDP,VXP	

Ref. No.	Part No.	Description	Reqd. QTY				Serial No.	Parts catalogue code
			GX160K1					
			(1)	(2)	(3)	(4)		
(1)	13012-ZF1-024	RING SET, PISTON (0.50)						
		(NIPPON)	(1)	-	(1)	-	-----	EMA,EMA2,EN,ET,ETX,HG1,HXQ,LAX,LAX2,LJD,LSS1,LTA,LTk,PM,QAX QBU2,QNT2,QXB,QXF,QXS,QZ,RAC,RFR,RHA,SAC,SAD2,SMB4,SSK2,STA SWX,SW2,UIH,VA,VEB2,VHQ4,VSW,VS1,VTE2,VWA,VXE,VXW,VXW1
			(1)	-	-	-	-----	4733210 PHU,RD,RD4,RH,RHQ4,RH2,RSK,RXE4,RX4,SMJ,SMJ1,THU,TH2,VEBM,VED VED1,VED2,VED3,VH,VHH4,VMS4,VS,VSX,VSX1,VS3,VS4,VX,VXE4,VXU VX2,VX26,VX4,WKT2,WMB0
			(1)	-	-	-	-----	4764118 SWG4
			(1)	-	-	-	-----	5495899 AR,ARC6,DS,DSP,HG12,HH,HHQ4,HH26,HX,HXE,HX2,HX26,HX4,KR,KTA,LD LDB1,LDB3,LDM,LD4,LH,LHB3,LHQ4,LJ,LJC7,LJG,LJS,LMT,LSJ,LSJ4 LSS,LSS4,LW2,LX,LX2,LX26,LX4,NJ,NJG,NSJ,NW,PH,PHM,PM2,PX,FX2 QA,QAB1,QAB3,QAX2,QA2,QA26,QBT2,QBT6,QD,QE,QFE4,QGR2,QH,QHE QHP1,QHQ4,QH26,QKA4,QM,QMC6,QMC8,QMD6,QME4,QMH,QMX2,QMZ2,QNT QNT4,QNZ,QP,QPU,QSC2,QT,QWM2,QWX2,QX,QXB1,QXC,QXC6,QXC9,QXE QXE2,QXE4,QXE6,QXF2,QXM1,QXQ,QXS2,QXW,QXW2,QX2,QX26,QX4,REX4 RFR2,RHA2,RH2,RH26,RMB4,RMD,RMG2,RNG,RTB2,RX,RXE,SCJ,SD,SDB1,SDB3 SDN,SDS,SDS2,SDS3,SD16,SD4,SE,SEE,SG24,SH,SHM,SHQ4,SJ,SJC,SJC1 SJC5,SJG,SKM,SMC7,SMC9,SMW2,SSK1,SSX2,ST,STP,STQ,SX,SXB,SXE SXE4,SX4,TH,TX,TC9,TX2,TX26,TX4,UH,UX,VA2,VED5,VW12,VXD,VXD1,VXE6 VXG,VXM,WJP
			-	(1)	-	-	-----	5495899
			-	-	-	(1)	-----	2000029 VSDP,VXP
	13013-ZF1-023	RING SET, PISTON (0.75)						
		(TEIKOKU)	(1)	-	(1)	-	-----	EMA,EMA2,EN,ET,ETX,HG1,HXQ,LAX,LAX2,LJD,LSS1,LTA,LTk,PM,QAX QBU2,QMC6,QNT2,QXB,QXF,QXS,QZ,RAC,RFR,RHA,SAC,SAD2,SMB4,SSK2 STA,SWX,SW2,UIH,VA,VEB2,VHQ4,VSW,VS1,VTD,VTD1,VTE2,VWA,VXE,VXW VXW1
			(1)	-	-	-	-----	4733210 PHU,RD,RD4,RHQ4,RSK,RXE4,RX4,SMJ,SMJ1,THU,VEBM,VED,VED1,VED2 VED3,VH,VHH4,VMS4,VS,VSX,VSX1,VS3,VS4,VXE4,VXU,VX26,VX4,WKT2 WMB0
			(1)	-	-	-	-----	4764118 SWG4
			(1)	-	-	-	-----	5495899 AR,ARC6,DS,DSP,HG12,HH,HHQ4,HH26,HX,HXE,HX2,HX26,HX4,KR,KTA,LD LDB1,LDB3,LDM,LD4,LH,LHB3,LHQ4,LJ,LJC7,LJG,LJS,LMT,LSJ,LSJ4 LSS,LSS4,LW2,LX,LX2,LX26,LX4,NJ,NJG,NSJ,NW,PH,PHM,PM2,PX,FX2 QA,QAB1,QAB3,QAX2,QA2,QA26,QBT2,QBT6,QD,QE,QFE4,QGR2,QH,QHE QHP1,QHQ4,QH26,QKA4,QM,QMC8,QMD6,QME4,QMH,QMX2,QMZ2,QNT,QNT4 QNZ,QP,QPU,QSC2,QT,QWM2,QWX2,QX,QXB1,QXC,QXC6,QXC9,QXE,QXE2 QXE4,QXE6,QXF2,QXM1,QXQ,QXS2,QXW,QXW2,QX2,QX26,QX4,REX4,RFR2 RH,RHA2,RH2,RH26,RMB4,RMD,RMG2,RNG,RTB2,RX,RXE,SCJ,SD,SDB1 SDB3,SDN,SDS,SDS2,SDS3,SD16,SD4,SE,SEE,SG24,SH,SHM,SHQ4,SJ,SJC SJC1,SJC5,SJG,SKM,SMC7,SMC9,SMW2,SSK1,SSX2,ST,STP,STQ,SX,SXB SXE,SXE4,SX4,TH,TX,TC9,TX2,TX26,TX4,UH,UX,VA2,VED5,VW12,VX VXD,VXD1,VXE6,VXG,VXM,VX2,WJP
			-	(1)	-	-	-----	5495899
			-	-	-	(1)	-----	2000029 VSDP,VXP



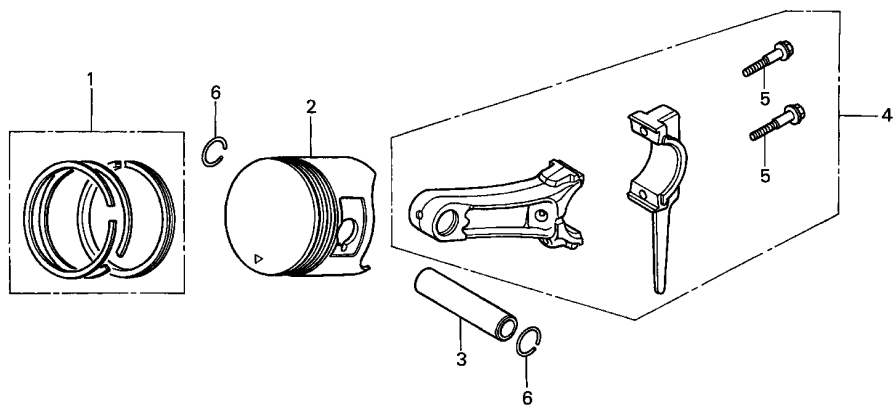

ZH80-E0800



Ref. No.	Part No.	Description	Reqd. QTY				Serial No.	Parts catalogue code
			(1)	(2)	(3)	(4)		
(1)	13013-ZF1-024	RING SET, PISTON (0.75) (NIPPON)	(1)	-	(1)	-	-----	EMA,EMA2,EN,ET,ETX,HG1,HXQ,LAX,LAX2,LJD,LSS1,LTA,LTk,PM,QAX,QBU2,QMC6,QNT2,QXB,QXF,QXS,QZ,RAC,RFR,RHA,SAC,SAD2,SMB4,SSK2,STA,SWX,SW2,UIH,VA,VEB2,VHQ4,VSW,VS1,VTD,VTD1,VTE2,VWA,VXE,VXW1
			(1)	-	-	-	-----	4733210 PHU,RD,RD4,RHQ4,RSK,RXE4,RX4,SMJ,SMJ1,THU,VEBM,VED,VED1,VED2,VED3,VH,VHH4,VMS4,VS,VSX,VSX1,VS3,VS4,VXE4,VXU,VX26,VX4,WKT2,WMB0
			(1)	-	-	-	-----	4764118 SWG4
			(1)	-	-	-	-----	5495899 AR,ARC6,DS,DSP,HG12,HH,HHQ4,HH26,HX,HXE,HX2,HX26,HX4,KR,KTA,LD,LDB1,LDB3,LDM,LD4,LH,LHB3,LHQ4,LJ,LJC7,LJG,LJS,LMT,LSJ,LSJ4,LSS,LSS4,LW2,LX,LX2,LX26,LX4,NJ,NJG,NSJ,NW,PH,PHM,PM2,PX,PX2,QA,QAB1,QAB3,QAX2,QA2,QA26,QBT2,QBT6,QD,QE,QFE4,QGR2,QH,QHE,QHP1,QHQ4,QH26,QKA4,QM,QMC8,QMD6,QME4,QMH,QMX2,QM2,QNT,QNT4,QNZ,QP,QPU,QSC2,QT,QWM2,QWX2,QX,QXB1,QXC,QXC6,QXC9,QXE,QXE2,QXE4,QXE6,QXF2,QXM1,QXQ,QXS2,QXW,QXW2,QX2,QX26,QX4,REX4,RFR2,RH,RHA2,RH2,RH26,RMB4,RMD,RMG2,RNG,RTB2,RX,RXE,SCJ,SD,SDB1,SDB3,SDN,SDS,SDS2,SDS3,SD16,SD4,SE,SEE,SG24,SH,SHM,SHQ4,SJ,SJC,SJC1,SJC5,SJG,SKM,SMC7,SMC9,SMW2,SSK1,SSX2,ST,STP,STQ,SX,SXB,SXE,SXE4,SX4,TH,TX,TXC9,TX2,TX26,TX4,UH,UX,VA2,VED5,VW12,VX,VXD,VXD1,VXE6,VXG,VXM,VX2,WJP
			-	(1)	-	-	-----	5495899
			-	-	-	(1)	-----	2000029 VSDP,VXP

Ref. No.	Part No.	Description	Reqd. QTY				Serial No.	Parts catalogue code
			GX160K1					
			(1)	(2)	(3)	(4)		
(1)	13010-ZH8-941	RING SET, PISTON (STD.) (TEIKOKU)	1	1	-	-	5495900 ----- DS,DSP,EMA,H1,LDB1,LDB3,LDM,LD4,LJD,LMT,LSJ,LSS,LSS1,LSS4,LTK NW,PH,PM2,PX,PX2,QA,QBT2,QWM2,QXB1,QXQ,Q1,REX4,RNG,R1,SDB1,SDN SDS2,SDS3,SEE,SJC,STA,STP,SXB,S1,TH,T1,U1,VXD1,VXE6,VXG,V1,W1	
			1	1	-	-	5495900 7603338 AR,ARC6,HG12,HH,HHQ4,HH26,HX,HXE,HX2,HX26,HX4,KR,KTA,LD,LH LHB3,LHQ4,LJ,LJC7,LJG,LJS,LSJ4,LW2,LX,LX2,LX26,LX4,L1,NJ,NJG NSJ,PHM,QAB1,QAB3,QAX2,QA2,QA26,QBT6,QD,QE,QFE4,QGR2,QH,QHE QHP1,QHQ4,QH26,QKA4,QM,QMC8,QMD6,QME4,QMH,QMX2,QM22,QNT,QNT4 QNZ,QP,QPU,QSC2,QT,QWX2,QX,QXC,QXC6,QXC9,QXE,QXE2,QXE4,QXE6 QXF2,QXM1,QXS2,QXW,QXW2,QX2,QX26,QX4,RFR2,RHA2,RH26,RMB4,RMD RMG2,RTB2,RX,RXE,SCJ,SD,SDB3,SDS,SD16,SD4,SE,SG24,SH,SHM,SHQ4 SJ,SJC1,SJC5,SJG,SKM,SMC7,SMC9,SMW2,SSK1,SSX2,ST,STM,STQ, SX SXE,SXE4, SX4, TX, TXC9, TX26, TX4, UH, UX, VA2, VED5, VW12, VXD, VXM, WJP	
			1	-	1	-	----- LHW,QWX3,UIH,VED7, VTD1, VTX	
			1	-	-	-	4733211 ----- PHU,THU,VH,VS,VX26	
			1	-	-	-	7603338 BL,HXE8,HXU,LXU,NJC1,PXU,QCB2,QCL,QGR9,QI2,QMC6,QSC9,QWA4,QXE8 QXU,QX22,RSS1,RXU,SHRY,SHR4,SMX4,SM11,SM12,SM14,SNX,SNX1,SWX2 SWX4,SXS4,SXU,S1CY,TCS2,TXU,UXU,VED6,VGE4,VG24,VMB3, VMT, VPM4 VPR4,VSB1,VSD,VSD1,VSX3, VTD, VTU1, VTX1, VWA2, VXU1, VXW2, WDA6, WKD6 WKT4,WME2,WME4,WMT	
			1	-	-	-	4733211 7603338 RD,RD4,RH,RHQ4,RH2,RSK,RXE4,RX4,SMJ,SMJ1, TX2, VEBM, VED, VED1 VED2,VED3,VHH4,VMS4,VSX,VSX1,VS3,VS4,VX,VXE4,VXU,VX2,VX4,WKT2 WMBO	
			1	-	-	-	4764119 7603338 SWG4	
			-	-	-	1	2000030 ----- VSDP	
			-	-	-	1	2000214 SXP1	
			-	-	-	1	2000030 2000214 VXP	
	13010-ZH8-942	RING SET, PISTON (STD.) (NIPPON)	1	1	-	-	5495900 ----- DS,DSP,EMA,H1,LDB1,LDB3,LDM,LD4,LJD,LMT,LSJ,LSS,LSS1,LSS4,LTK NW,PH,PM2,PX,PX2,QA,QBT2,QWM2,QXB1,QXQ,Q1,REX4,RNG,R1,SDB1,SDN SDS2,SDS3,SEE,SJC,STA,STP,SXB,S1,TH,T1,U1,VXD1,VXE6,VXG,V1,W1	
			1	1	-	-	5495900 7603338 AR,ARC6,HG12,HH,HHQ4,HH26,HX,HXE,HX2,HX26,HX4,KR,KTA,LD,LH LHB3,LHQ4,LJ,LJC7,LJG,LJS,LSJ4,LW2,LX,LX2,LX26,LX4,L1,NJ,NJG NSJ,PHM,QAB1,QAB3,QAX2,QA2,QA26,QBT6,QD,QE,QFE4,QGR2,QH,QHE QHP1,QHQ4,QH26,QKA4,QM,QMC8,QMD6,QME4,QMH,QMX2,QM22,QNT,QNT4 QNZ,QP,QPU,QSC2,QT,QWX2,QX,QXC,QXC6,QXC9,QXE,QXE2,QXE4,QXE6 QXF2,QXM1,QXS2,QXW,QXW2,QX2,QX26,QX4,RFR2,RHA2,RH26,RMB4,RMD RMG2,RTB2,RX,RXE,SCJ,SD,SDB3,SDS,SD16,SD4,SE,SG24,SH,SHM,SHQ4 SJ,SJC1,SJC5,SJG,SKM,SMC7,SMC9,SMW2,SSK1,SSX2,ST,STM,STQ, SX SXE,SXE4, SX4, TX, TXC9, TX26, TX4, UH, UX, VA2, VED5, VW12, VXD, VXM, WJP	
			1	-	1	-	----- LHW,QWX3,UIH,VED7, VTD1, VTX	
			1	-	-	-	4733211 ----- PHU,THU,VH,VS,VX26	
			1	-	-	-	7603338 BL,HXE8,HXU,LXU,NJC1,PXU,QCB2,QCL,QGR9,QI2,QMC6,QSC9,QWA4,QXE8 QXU,QX22,RSS1,RXU,SHRY,SHR4,SMX4,SM11,SM12,SM14,SNX,SNX1,SWX2 SWX4,SXS4,SXU,S1CY,TCS2,TXU,UXU,VED6,VGE4,VG24,VMB3, VMT, VPM4 VPR4,VSB1,VSD,VSD1,VSX3, VTD, VTU1, VTX1, VWA2, VXU1, VXW2, WDA6, WKD6 WKT4,WME2,WME4,WMT	
			1	-	-	-	4733211 7603338 RD,RD4,RH,RHQ4,RH2,RSK,RXE4,RX4,SMJ,SMJ1, TX2, VEBM, VED, VED1 VED2,VED3,VHH4,VMS4,VSX,VSX1,VS3,VS4,VX,VXE4,VXU,VX2,VX4,WKT2 WMBO	
			1	-	-	-	4764119 7603338 SWG4	
			-	-	-	1	2000030 ----- VSDP	
			-	-	-	1	2000214 SXP1	
			-	-	-	1	2000030 2000214 VXP	

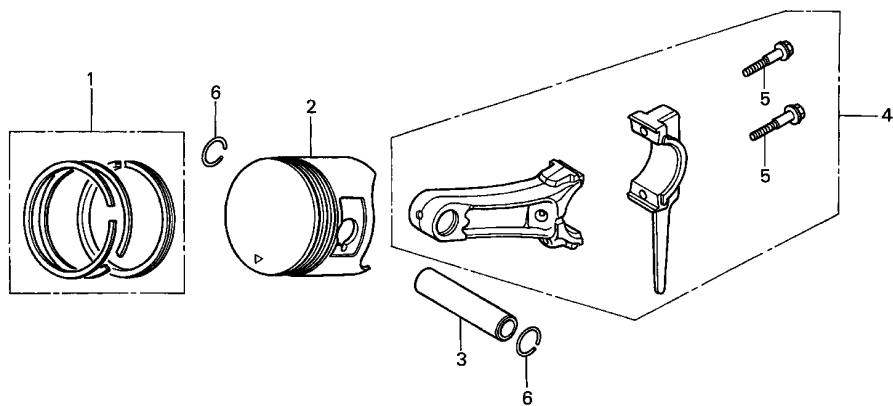

ZH80-E0800



Ref. No.	Part No.	Description	Reqd. QTY				Serial No.	Parts catalogue code
			(1)	(2)	(3)	(4)		
			GX160K1					
(1)	13011-ZH8-941	RING SET, PISTON (0.25) (TEIKOKU)	(1)	(1)	-	-	5495900	DS, DSP, EMA, H1, LDB1, LDB3, LDM, LD4, LJD, LMT, LSJ, LSS, LSS1, LSS4, LTK, NW, PH, PM2, PX, PX2, QA, QBT2, QWM2, QXB1, QXQ, Q1, REX4, RNG, R1, SDB1, SDN, SDS2, SDS3, SEE, SJC, STA, STP, SXB, S1, TH, T1, U1, VXD1, VXE6, VXG, V1, W1
			(1)	(1)	-	-	5495900 7603338	AR, ARC6, HG12, HH, HHQ4, HH26, HX, HXE, HX2, HX26, HX4, KR, KTA, LD, LH, LHB3, LHQ4, LJ, LJ7, LJG, LJS, LSJ4, LW2, LX, LX2, LX26, LX4, L1, NJ, NJG, NSJ, PHM, QAB1, QAB3, QAX2, QA2, QA26, QBT6, QD, QE, QFE4, QGR2, QH, QHE, QHP1, QHQ4, QH26, QKA4, QM, QMC8, QMD6, QME4, QMH, QMX2, QMZ2, QNT, QNT4, QNZ, QP, QPU, QSC2, QT, QWX2, QX, QXC, QXC6, QXC9, QXE, QXE2, QXE4, QXE6, QXF2, QXM1, QXS2, QXW, QXW2, QX2, QX26, QX4, RFR2, RHA2, RH26, RMB4, RMD, RMG2, RTB2, RX, RXE, SCJ, SD, SDB3, SDS, SD16, SD4, SE, SG24, SH, SHM, SHQ4, SJ, SJC1, SJC5, SJG, SKM, SMC7, SMC9, SMW2, SSK1, SSS2, ST, STM, STQ, SX, SXE, SXE4, SX4, TX, TXC9, TX26, TX4, UH, UX, VA2, VED3, VED5, VW12, VXD, VXM, WJP
			(1)	-	(1)	-	-----	LHW, QWX3, UIH, VED7, VTD1, VTX
			(1)	-	-	-	4733211	PHU, THU, VH, VS, VX26
			(1)	-	-	-	7603338	BL, HXE8, HXU, LXU, NJC1, PXU, QCB2, QCL, QGR9, QI2, QMC6, QSC9, QWA4, QXE8, QXU, QX22, RSS1, RXU, SHRY, SHR4, SMX4, SM11, SM12, SM14, SNX, SNX1, SWX2, SWX4, SXS4, SXU, S1CY, TCS2, TXU, UXU, VGE4, VG24, VMB3, VPM4, VPR4, VSB1, VSD, VSD1, VSX3, VTD, VTU1, VTX1, VWA2, VXU1, VXW2, WDA6, WKD6, WKT4, WME2, WME4, WMT
			(1)	-	-	-	4733211 7603338	RD, RD4, RH, RHQ4, RH2, RSK, RXE4, RX4, SMJ, SMJ1, TX2, VEBM, VED, VED1, VHH4, VMS4, VSX, VSX1, VX, VXE4, VXU, VX2, VX4, WKT2, WMBO
			(1)	-	-	-	4764119 7603338	SWG4
			-	-	-	(1)	2000030	VSDP
			-	-	-	(1)	2000214	SXP1
			-	-	-	(1)	2000030	VXP

Ref. No.	Part No.	Description	Reqd. QTY				Serial No.	Parts catalogue code
			GX160K1					
			(1)	(2)	(3)	(4)		
(1)	13011-ZH8-942	RING SET, PISTON (0.25)						
		(NIPPON)	(1)	(1)	-	-	5495900 ----- DS,DSP,EMA,H1,LDB1,LDB3,LDM,LD4,LJD,LMT,LSJ,LSS,LSS1,LSS4,LTK,NW,PH,PM2,PX,PX2,QA,QBT2,QWM2,QXB1,QXQ,Q1,REX4,RNG,R1,SDB1,SDN,SDS2,SDS3,SEE,SJC,STA,STP,SXB,S1,TH,T1,U1,VXD1,VXE6,VXG,V1,W1	
			(1)	(1)	-	-	5495900 7603338 AR,ARC6,HG12,HH,HHQ4,HH26,HX,HXE,HX2,HX26,HX4,KR,KTA,LD,LH,LHB3,LHQ4,LJ,LJC7,LJG,LJS,LSJ4,LW2,LX,LX2,LX26,LX4,L1,NJ,NJG,NSJ,PHM,QAB1,QAB3,QAX2,QA2,QA26,QBT6,QD,QE,QFE4,QGR2,QH,QHE,QHP1,QHQ4,QH26,QKA4,QM,QMC8,QMD6,QME4,QMH,QMX2,QM22,QNT,QNT4,QNZ,QP,QPU,QSC2,QT,QWX2,QX,QXC,QXC6,QXC9,QXE,QXE2,QXE4,QXE6,QXF2,QXM1,QXS2,QXW,QXW2,QX2,QX26,QX4,RFR2,RHA2,RH26,RMB4,RMD,RMG2,RTB2,RX,RXE,SCJ,SD,SDB3,SDS,SD16,SD4,SE,SG24,SH,SHM,SHQ4,SJ,SJC1,SJC5,SJG,SKM,SMC7,SMC9,SMW2,SSK1,SSX2,ST,STM,STQ,SX,SXE,SXE4,SX4,TX,TXC9,TX26,TX4,UH,UX,VA2,VED3,VED5,VW12,VXD,VXM,WJP	
			(1)	-	(1)	-	----- LHW,QWX3,UIH,VED7,VTD1,VTX	
			(1)	-	-	-	4733211 ----- PHU,THU,VH,VS,VX26	
			(1)	-	-	-	7603338 BL,HXE8,HXU,LXU,NJC1,PXU,QCB2,QCL,QGR9,QI2,QMC6,QSC9,QWA4,QXE8,QXU,QX22,RSS1,RXU,SHRY,SHR4,SMX4,SM11,SM12,SM14,SNX,SNX1,SWX2,SWX4,SXS4,SXU,S1CY,TCS2,TXU,UXU,VGE4,VG24,VMB3,VP4,VPR4,VSB1,VSD,VSD1,VSX3,VTD,VTU1,VTX1,VWA2,VXU1,VXW2,WDA6,WKD6,WKT4,WME2,WME4,WMT	
			(1)	-	-	-	4733211 7603338 RD,RD4,RH,RHQ4,RH2,RSK,RXE4,RX4,SMJ,SMJ1,TX2,VEBM,VED,VED1,VHH4,VMS4,VSX,VSX1,VX,VXE4,VXU,VX2,VX4,WKT2,WMB0	
			(1)	-	-	-	4764119 7603338 SWG4	
			-	-	-	(1)	2000030 ----- VSDP	
			-	-	-	(1)	2000214 SXP1	
			-	-	-	(1)	2000030 2000214 VXP	
	13012-ZH8-941	RING SET, PISTON (0.50)						
		(TEIKOKU)	(1)	(1)	-	-	5495900 ----- DS,DSP,EMA,H1,LDB1,LDB3,LDM,LD4,LJD,LMT,LSJ,LSS,LSS1,LSS4,LTK,NW,PH,PM2,PX,PX2,QA,QBT2,QWM2,QXB1,QXQ,Q1,REX4,RNG,R1,SDB1,SDN,SDS2,SDS3,SEE,SJC,STA,STP,SXB,S1,TH,T1,U1,VXD1,VXE6,VXG,V1,W1	
			(1)	(1)	-	-	5495900 7603338 AR,ARC6,HG12,HH,HHQ4,HH26,HX,HXE,HX2,HX26,HX4,KR,KTA,LD,LH,LHB3,LHQ4,LJ,LJC7,LJG,LJS,LSJ4,LW2,LX,LX2,LX26,LX4,L1,NJ,NJG,NSJ,PHM,QAB1,QAB3,QAX2,QA2,QA26,QBT6,QD,QE,QFE4,QGR2,QH,QHE,QHP1,QHQ4,QH26,QKA4,QM,QMC8,QMD6,QME4,QMH,QMX2,QM22,QNT,QNT4,QNZ,QP,QPU,QSC2,QT,QWX2,QX,QXC,QXC6,QXC9,QXE,QXE2,QXE4,QXE6,QXF2,QXM1,QXS2,QXW,QXW2,QX2,QX26,QX4,RFR2,RHA2,RH26,RMB4,RMD,RMG2,RTB2,RX,RXE,SCJ,SD,SDB3,SDS,SD16,SD4,SE,SG24,SH,SHM,SHQ4,SJ,SJC1,SJC5,SJG,SKM,SMC7,SMC9,SMW2,SSK1,SSX2,ST,STM,STQ,SX,SXE,SXE4,SX4,TX,TXC9,TX26,TX4,UH,UX,VA2,VED5,VW12,VXD,VXM,WJP	
			(1)	-	(1)	-	----- LHW,QWX3,UIH,VED7,VTD1,VTX	
			(1)	-	-	-	4733211 ----- PHU,THU,VH,VS,VX26	
			(1)	-	-	-	7603338 BL,HXE8,HXU,LXU,NJC1,PXU,QCB2,QCL,QGR9,QI2,QMC6,QSC9,QWA4,QXE8,QXU,QX22,RSS1,RXU,SHRY,SHR4,SMX4,SM11,SM12,SM14,SNX,SNX1,SWX2,SWX4,SXS4,SXU,S1CY,TCS2,TXU,UXU,VGE4,VG24,VMB3,VP4,VPR4,VSB1,VSD,VSD1,VSX3,VTD,VTU1,VTX1,VWA2,VXU1,VXW2,WDA6,WKD6,WKT4,WME2,WME4,WMT	
			(1)	-	-	-	4733211 7603338 RD,RD4,RH,RHQ4,RH2,RSK,RXE4,RX4,SMJ,SMJ1,TX2,VEBM,VED,VED1,VED2,VED3,VHH4,VMS4,VSX,VSX1,VS3,VS4,VX,VXE4,VXU,VX2,VX4,WKT2,WMB0	
			(1)	-	-	-	4764119 7603338 SWG4	
			-	-	-	(1)	2000030 ----- VSDP	
			-	-	-	(1)	2000214 SXP1	
			-	-	-	(1)	2000030 2000214 VXP	

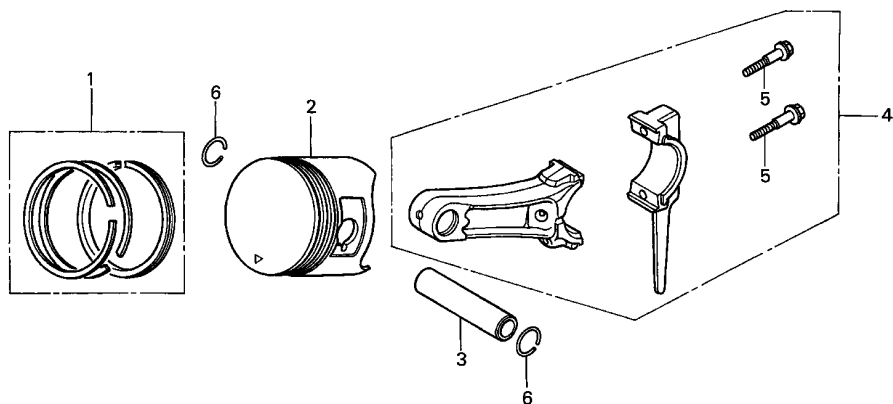

ZH80-E0800



2

Ref. No.	Part No.	Description	Reqd. QTY				Serial No.	Parts catalogue code
			(1)	(2)	(3)	(4)		
(1)	13012-ZH8-942	RING SET, PISTON (0.50)						
		(NIPPON)	(1)	(1)	-	-	5495900	DS, DSP, EMA, H1, LDB1, LDB3, LDM, LD4, LJD, LMT, LSJ, LSS, LSS1, LSS4, LTK, NW, PH, PM2, PX, PX2, QA, QBT2, QWM2, QXB1, QXQ, Q1, REX4, RNG, R1, SDB1, SDN, SDS2, SDS3, SEE, SJC, STA, STP, SXB, S1, TH, T1, U1, VXD1, VXE6, VVG, V1, W1
			(1)	(1)	-	-	5495900 7603338	AR, ARC6, HG12, HH, HHQ4, HH26, HX, HXE, HX2, HX26, HX4, KR, KTA, LD, LH, LHB3, LHQ4, LJ, LJ C7, LJG, LJS, LSJ4, LW2, LX, LX2, LX26, LX4, L1, NJ, NJG, NSJ, PHM, QAB1, QAB3, QAX2, QA2, QA26, QBT6, QD, QE, QFE4, QGR2, QH, QHE, QHP1, QHQ4, QH26, QKA4, QM, QMC8, QMD6, QME4, QMH, QMX2, QMZ2, QNT, QNT4, QNZ, QP, QPU, QSC2, QT, QWX2, QX, QXC, QXC6, QXC9, QXE, QXE2, QXE4, QXE6, QXF2, QXM1, QXS2, QXW, QXW2, QX2, QX26, QX4, RFR2, RHA2, RH26, RMB4, RMD, RMG2, RTB2, RX, RXE, SCJ, SD, SDB3, SDS, SD16, SD4, SE, SG24, SH, SHM, SHQ4, SJ, SJC1, SJC5, SJG, SKM, SMC7, SMC9, SMW2, SSK1, SSS2, ST, STM, STQ, SX, SXE, SXE4, SX4, TX, TXC9, TX26, TX4, UH, UX, VA2, VED5, VW12, VXD, VXM, WJP
			(1)	-	(1)	-	-----	LHW, QWX3, UIH, VED7, VTD1, VTX
			(1)	-	-	-	4733211	PHU, THU, VH, VS, VX26
			(1)	-	-	-	----- 7603338	BL, HXE8, HXU, LXU, NJC1, PXU, QCB2, QCL, QGR9, QI2, QMC6, QSC9, QWA4, QXE8, QXU, QX22, RSS1, RXU, SHRY, SHR4, SMX4, SM11, SM12, SM14, SNX, SNX1, SWX2, SWX4, SXS4, SXU, S1CY, TCS2, TXU, UXU, VGE4, VG24, VMB3, VPM4, VPR4, VSB1, VSD, VSD1, VSX3, VTD, VTU1, VTX1, VWA2, VXU1, VXW2, WDA6, WKD6, WKT4, WME2, WME4, WMT
			(1)	-	-	-	4733211 7603338	RD, RD4, RH, RHQ4, RH2, RSK, RXE4, RX4, SMJ, SMJ1, TX2, VEBM, VED, VED1, VED2, VED3, VHH4, VMS4, VSX, VSX1, VS3, VS4, VX, VXE4, VXU, VX2, VX4, WKT2, WMB0
			(1)	-	-	-	4764119 7603338	SWG4
			-	-	-	(1)	2000030	VSDP
			-	-	-	(1)	2000214	SXP1
			-	-	-	(1)	2000030	VXP

Ref. No.	Part No.	Description	Reqd. QTY				Serial No.	Parts catalogue code
			GX160K1					
			(1)	(2)	(3)	(4)		
(1)	13013-ZH8-941	RING SET, PISTON (0.75)						
		(TEIKOKU)	(1)	(1)	-	-	5495900 ----- DS,DSP,EMA,H1,LDB1,LDB3,LDM,LD4,LJD,LMT,LSJ,LSS,LSS1,LSS4,LTK NW,PH,PM2,PX,PX2,QA,QBT2,QWM2,QXB1,QXQ,Q1,REX4,RNG,R1,SDB1,SDN SDS2,SDS3,SEE,SJC,STA,STP, SXB,S1,TH,T1,U1,VXD1,VXE6,VXG,V1,W1	
			(1)	(1)	-	-	5495900 7603338 AR,ARC6,HG12,HH,HHQ4,HH26,HX,HXE,HX2,HX26,HX4,KR,KTA,LD,LH LHB3,LHQ4,LJ,LJC7,LJG,LJS,LSJ4,LW2,LX,LX2,LX26,LX4,L1,NJ,NJG NSJ,PHM,QAB1,QAB3,QAX2,QA2,QA26,QBT6,QD,QE,QFE4,QGR2,QH,QHE QHP1,QHQ4,QH26,QKA4,QM,QMC8,QMD6,QME4,QMH,QMX2,QM22,QNT,QNT4 QNZ,QP,QPU,QSC2,QT,QWX2,QX,QXC,QXC6,QXC9,QXE,QXE2,QXE4,QXE6 QXF2,QXM1,QXS2,QXW,QXW2,QX2,QX26,QX4,RFR2,RH,RHA2,RH2,RH26 RMB4,RMD,RMG2,RTB2,RX,RXE,SCJ,SD,SDB3,SDS,SD16,SD4,SE,SG24,SH SHM,SHQ4,SJ,SJC1,SJC5,SJG,SKM,SMC7,SMC9,SMW2,SSK1,SSX2,ST,STM STQ,SX,SXE,SXE4,SX4,TX,TC9,TX2,TX26,TX4,UH,UX,VA2,VED5,VW12 VX,VXD,VXM,VX2,WJP	
			(1)	-	(1)	-	----- LHW,QWX3,UIH,VED7,VTD1,VTX	
			(1)	-	-	-	4733211 ----- PHU,THU,VH,VS,VX26	
			(1)	-	-	-	7603338 BL,HXE8,HXU,LXU,NJC1, PXU,QCB2,QCL,QGR9,QI2,QMC6,QSC9,QWA4,QXE8 QXU,QX22,RSS1,RXU,SHRY,SHR4,SMX4,SM11,SM12,SM14,SNX,SNX1,SWX2 SWX4,SXS4,SXU,S1CY,TCS2,TXU,UXU,VED6,VGE4,VG24,VMB3,VPM4,VPR4 VSB1,VSD,VSD1,VSX3, VTD,VTU1,VTX1,VWA2,VXU1,VXW2,WDA6,WKD6,WKT4 WME2,WME4,WMT	
			(1)	-	-	-	4733211 7603338 RD,RD4,RHQ4,RSK,RXE4,RX4,SMJ,SMJ1,VEBM,VED,VED1,VED2,VED3,VHH4 VMS4,VSX,VSX1,VS3,VS4,VXE4,VXU,VX4,WKT2,WMB0	
			(1)	-	-	-	4764119 7603338 SWG4	
			-	-	-	(1)	2000030 ----- VSDP	
			-	-	-	(1)	2000214 SXP1	
			-	-	-	(1)	2000030 2000214 VXP	
	13013-ZH8-942	RING SET, PISTON (0.75)						
		(NIPPON)	(1)	(1)	(1)	-	5495900 ----- DS,DSP,EMA,H1,LDB1,LDB3,LDM,LD4,LJD,LMT,LSJ,LSS,LSS1,LSS4,LTK NW,PH,PM2,PX,PX2,QA,QBT2,QWM2,QXB1,QXQ,Q1,REX4,RNG,R1,SDB1,SDN SDS2,SDS3,SEE,SJC,STA,STP, SXB,S1,TH,T1,UIH,U1,VXD1,VXE6,VXG,V1 W1	
			(1)	(1)	-	-	5495900 7603338 AR,ARC6,HG12,HH,HHQ4,HH26,HX,HXE,HX2,HX26,HX4,KR,KTA,LD,LH LHB3,LHQ4,LJ,LJC7,LJG,LJS,LSJ4,LW2,LX,LX2,LX26,LX4,L1,NJ,NJG NSJ,PHM,QAB1,QAB3,QAX2,QA2,QA26,QBT6,QD,QE,QFE4,QGR2,QH,QHE QHP1,QHQ4,QH26,QKA4,QM,QMC8,QMD6,QME4,QMH,QMX2,QM22,QNT,QNT4 QNZ,QP,QPU,QSC2,QT,QWX2,QX,QXC,QXC6,QXC9,QXE,QXE2,QXE4,QXE6 QXF2,QXM1,QXS2,QXW,QXW2,QX2,QX26,QX4,RFR2,RH,RHA2,RH2,RH26 RMB4,RMD,RMG2,RTB2,RX,RXE,SCJ,SD,SDB3,SDS,SD16,SD4,SE,SG24,SH SHM,SHQ4,SJ,SJC1,SJC5,SJG,SKM,SMC7,SMC9,SMW2,SSK1,SSX2,ST,STM STQ,SX,SXE,SXE4,SX4,TX,TC9,TX2,TX26,TX4,UH,UX,VA2,VED5,VW12 VX,VXD,VXM,VXU,VXU1,VX2,WJP	
			(1)	-	-	-	----- LHW,QWX3,VED7,VTD1,VTX	
			(1)	-	-	-	4733211 ----- PHU,THU,VH,VS,VXE,VX26	
			(1)	-	-	-	7603338 BL,HXE8,HXU,LXU,NJC1, PXU,QCB2,QCL,QGR9,QI2,QMC6,QSC9,QWA4,QXE8 QXU,QX22,RSS1,RXU,SHRY,SHR4,SMX4,SM11,SM12,SM14,SNX,SNX1,SWX2 SWX4,SXS4,SXU,S1CY,TCS2,TXU,UXU,VED6,VGE4,VG24,VMB3,VPM4,VPR4 VSB1,VSD,VSD1,VSX3, VTD,VTU1,VTX1,VWA2,VXW2,WDA6,WKD6,WKT4,WME2 WME4,WMT	
			(1)	-	-	-	4733211 7603338 RD,RD4,RHQ4,RSK,RXE4,RX4,SMJ,SMJ1,VEBM,VED,VED1,VED2,VED3,VHH4 VMS4,VSX,VSX1,VS3,VS4,VXE4,VX4,WKT2,WMB0	
			(1)	-	-	-	4764119 7603338 SWG4	
			-	-	-	(1)	2000030 ----- VSDP	
			-	-	-	(1)	2000214 SXP1	
			-	-	-	(1)	2000030 2000214 VXP	

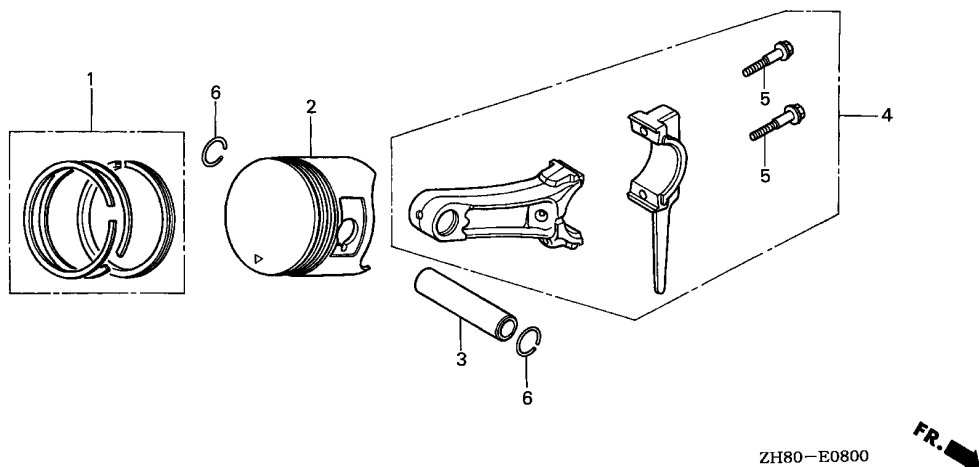

2

Ref. No.	Part No.	Description	Reqd. QTY				Serial No.	Parts catalogue code
			(1)	(2)	(3)	(4)		
			GX160K1					
(1)	13010-ZL0-003	RING SET, PISTON (STD.) (TEIKOKU)	1	1	-	-	7603339	AR, ARC6, BL, EMA2, HG12, HH, HHQ4, HH26, HX, HXE, HXE8, HXU, HX2, HX26, HX4, KR, KTA, LD, LH, LHB3, LHQ4, LJ, LJC7, LJG, LJS, LSJ4, LW2, LX, LXU, LX2, LX26, LX4, L1, NJ, NJC1, NJG, NSJ, PHM, PXU, QAB1, QAB3, QAX2, QA2, QA26, QBT6, QCB2, QCL, QD, QE, QFE4, QGR2, QGR9, QH, QHE, QHP1, QHQ4, QH26, QI2, QKA4, QM, QMC6, QMC8, QMD6, QME4, QMH, QMX2, QM22, QNT, QNT4, QNZ, QP, QPU, QSC2, QSC9, QT, QWA4, QWX2, QX, QXC, QXC6, QXC9, QXE, QXE2, QXE4, QXE6, QXE8, QXF2, QXM1, QXS2, QXU, QXW, QXW2, QX2, QX22, QX26, QX4, RD, RD4, RFR2, RH, RHA2, RHQ4, RH2, RH26, RMB4, RMD, RMG2, RSK, RSS1, RTB2, RX, RXE, RXE4, RXU, RX4, SCJ, SD, SDB3, SDS, SD16, SD4, SE, SG24, SH, SHM, SHQ4, SHRY, SHR4, SJ, SJC1, SJC5, SJG, SKM, SMC7, SMC9, SMJ, SMJ1, SMW2, SMX4, SM11, SM12, SM14, SNX, SNX1, SSK1, SSS2, ST, STM, STQ, SWG4, SWX2, SWX4, SX, SXE, SXE4, SXS4, SXU, SX4, S1CY, TCS2, TX, TXC9, TXU, TX2, TX26, TX4, UH, UX, UXU, VA2, VEBM, VED, VED1, VED2, VED3, VED5, VED6, VGE4, VG24, VHH4, VMB3, VMS4, VMT, VPM4, VPR4, VSB1, VSD, VSD1, VSX, VSX1, VSX3, VS3, VS4, VTD, VTU1, VTX1, VWA2, VW12, VX, VXD, VXE4, VXM, VXU, VXU1, VXW2, VX2, VX4, WDA6, WJP, WKD6, WKT2, WKT4, WMBO, WME2, WME4, WMT, HXE2, LVL, QBC2, QIH1, QS2, QVL, QX7, RXE2, SX7, VEN2, VES, VHA7, VIH1, VMS7, VPM5, VPM7, VPR7, VSD7, VSG, VS17, VXE7, WIH1, WKT6, SXP1, VXP
			-	-	-	1	2000215	

Ref. No.	Part No.	Description	Reqd. QTY				Serial No.	Parts catalogue code
			GX160K1					
			(1)	(2)	(3)	(4)		
(1)	13010-ZL0-004	RING SET, PISTON (STD.) (NIPPON)	1	1	-	-	7603339 -----	AR,ARC6,BL,EMA2,HG12,HH,HHQ4,HH26,HX,HXE,HXE8,HXU,HX2,HX26,HX4 KR,KTA,LD,LH,LHB3,LHQ4,LJ,LJC7,LJG,LJS,LSJ4,LW2,LX,LXU,LX2 LX26,LX4,L1,NJ,NJC1,NJG,NSJ,PHM,PXU,QAB1,QAB3,QAX2,QA2,QA26 QBT6,QCB2,QCL,QD,QE,QFE4,QGR2,QGR9,QH,QHE,QHP1,QHQ4,QH26,QI2 QKA4,QM,QMC6,QMC8,QMD6,QME4,QMH,QMX2,QM22,QNT,QNT4,QNZ,QP,QPU QSC2,QSC9,QT,QWA4,QWX2,QX,QXC,QXC6,QXC9,QXE,QXE2,QXE4,QXE6 QXE8,QXF2,QXM1,QXS2,QXU,QXW,QXW2,QX2,QX22,QX26,QX4,RD,RD4,RFR2 RH,RHA2,RHQ4,RH2,RH26,RMB4,RMD,RMG2,RSK,RSS1,RTB2,RX,RXE,RXE4 RXU,RX4,SCJ,SD,SDB3,SDS,SD16,SD4,SE,SG24,SH,SHM,SHQ4,SHRY,SHR4 SJ,SJC1,SJC5,SJG,SKM,SMC7,SMC9,SMJ,SMJ1,SMW2,SMX4,SM11,SM12 SM14,SNX,SNX1,SSK1,SSX2,ST,STM,STQ,SWG4,SWX2,SWX4,SX,SXE,SXE4 SXS4,SXU,SX4,S1CY,TCS2,TX,TXC9,TXU,TX2,TX26,TX4,UH,UX,UXU,VA2 VEBM,VED,VED1,VED2,VED3,VED5,VED6,VGE4,VG24,VHH4,VMB3,VMS4,VMT VPM4,VPR4,VSB1,VSD,VSD1,VSX,VSX1,VSX3,VS3,VS4,VTD,VTU1,VTX1 VWA2,VW12,VX,VXD,VXE4,VXM,VXU,VXU1,VXW2,VX2,VX4,WDA6,WJP,WKD6 WKT2,WKT4,WMB0,WME2,WME4,WMT HXE2,LVL,QBC2,QIH1,QS2,QVL,QX7,RXE2,SX7,VEN2,VES,VHA7,VIH1 VMS7,VPM5,VPM7,VPR7,VSD7,VSG,VS17,VXE7,WIH1,WKT6 SXP1,VXP
	13011-ZL0-003	RING SET, PISTON (0.25) (TEIKOKU)	(1)	(1)	-	-	7603339 -----	AR,ARC6,BL,EMA2,HG12,HH,HHQ4,HH26,HX,HXE,HXE8,HXU,HX2,HX26,HX4 KR,KTA,LD,LH,LHB3,LHQ4,LJ,LJC7,LJG,LJS,LSJ4,LW2,LX,LXU,LX2 LX26,LX4,L1,NJ,NJC1,NJG,NSJ,PHM,PXU,QAB1,QAB3,QAX2,QA2,QA26 QBT6,QCB2,QCL,QD,QE,QFE4,QGR2,QGR9,QH,QHE,QHP1,QHQ4,QH26,QI2 QKA4,QM,QMC6,QMC8,QMD6,QME4,QMH,QMX2,QM22,QNT,QNT4,QNZ,QP,QPU QSC2,QSC9,QT,QWA4,QWX2,QX,QXC,QXC6,QXC9,QXE,QXE2,QXE4,QXE6 QXE8,QXF2,QXM1,QXS2,QXU,QXW,QXW2,QX2,QX22,QX26,QX4,RD,RD4,RFR2 RH,RHA2,RHQ4,RH2,RH26,RMB4,RMD,RMG2,RSK,RSS1,RTB2,RX,RXE,RXE4 RXU,RX4,SCJ,SD,SDB3,SDS,SD16,SD4,SE,SG24,SH,SHM,SHQ4,SHRY,SHR4 SJ,SJC1,SJC5,SJG,SKM,SMC7,SMC9,SMJ,SMJ1,SMW2,SMX4,SM11,SM12 SM14,SNX,SNX1,SSK1,SSX2,ST,STM,STQ,SWG4,SWX2,SWX4,SX,SXE,SXE4 SXS4,SXU,SX4,S1CY,TCS2,TX,TXC9,TXU,TX2,TX26,TX4,UH,UX,UXU,VA2 VEBM,VED,VED1,VED2,VED3,VED5,VED6,VGE4,VG24,VHH4,VMB3,VMS4,VMT VPM4,VPR4,VSB1,VSD,VSD1,VSX,VSX1,VSX3,VS3,VS4,VTD,VTU1,VTX1 VWA2,VW12,VX,VXD,VXE4,VXM,VXU,VXU1,VXW2,VX2,VX4,WDA6,WJP,WKD6 WKT2,WKT4,WMB0,WME2,WME4,WMT HXE2,LVL,QBC2,QIH1,QS2,QVL,QX7,RXE2,SX7,VEN2,VES,VHA7,VIH1 VMS7,VPM5,VPM7,VPR7,VSD7,VSG,VS17,VXE7,WIH1,WKT6 SXP1,VXP



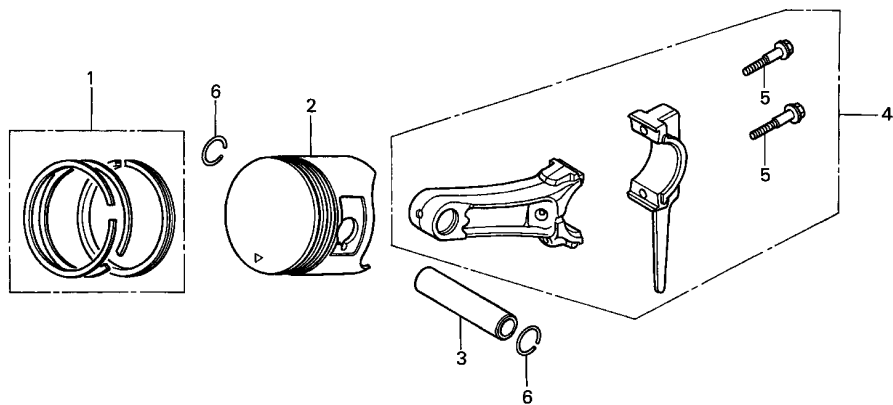

ZH80-E0800



2

Ref. No.	Part No.	Description	Reqd. QTY	Serial No.	Parts catalogue code
			GX160K1 (1) (2) (3) (4)		
(1)	13011-ZL0-004	RING SET, PISTON (0.25) (NIPPON)	(1) (1) - -	7603339	AR, ARC6, BL, EMA2, HG12, HH, HHQ4, HH26, HX, HXE, HXE8, HXU, HX2, HX26, HX4, KR, KTA, LD, LH, LHB3, LHQ4, LJ, LJC7, LJG, LJS, LSJ4, LW2, LX, LXU, LX2, LX26, LX4, L1, NJ, NJC1, NJG, NSJ, PHM, PXU, QAB1, QAB3, QAX2, QA2, QA26, QBT6, QCB2, QCL, QD, QE, QFE4, QGR2, QGR9, QH, QHE, QHP1, QHQ4, QH26, QI2, QKA4, QM, QMC6, QMC8, QMD6, QME4, QMH, QMX2, QM22, QNT, QNT4, QNZ, QP, QPU, QSC2, QSC9, QT, QWA4, QWX2, QX, QXC, QXC6, QXC9, QXE, QXE2, QXE4, QXE6, QXE8, QXF2, QXM1, QXS2, QXU, QXW, QXW2, QX2, QX22, QX26, QX4, RD, RD4, RFR2, RH, RHA2, RHQ4, RH2, RH26, RMB4, RMD, RMG2, RSK, RSS1, RTB2, RX, RXE, RXE4, RXU, RX4, SCJ, SD, SDB3, SDS, SD16, SD4, SE, SG24, SH, SHM, SHQ4, SHRY, SHR4, SJ, SJC1, SJC5, SJG, SKM, SMC7, SMC9, SMJ, SMJ1, SMW2, SMX4, SM11, SM12, SM14, SNX, SNX1, SSK1, SSSX2, ST, STM, STQ, SWG4, SWX2, SWX4, SX, SXE, SXE4, SXS4, SXU, SX4, S1CY, TCS2, TX, TXC9, TXU, TX2, TX26, TX4, UH, UX, UXU, VA2, VEBM, VED, VED1, VED2, VED3, VED5, VED6, VGE4, VG24, VHH4, VMB3, VMS4, VMT, VPM4, VPR4, VSB1, VSD, VSD1, VSX, VSX1, VSX3, VS3, VS4, VTD, VTU1, VTX1, VWA2, VW12, VX, VXD, VXE4, VXM, VXU, VXU1, VXW2, VX2, VX4, WDA6, WJP, WKD6, WKT2, WKT4, WMBO, WME2, WME4, WMT
			(1) - (1) -		HXE2, LVL, QBC2, QIH1, QS2, QVL, QX7, RXE2, SX7, VEN2, VES, VHA7, VIH1, VMS7, VPM5, VPM7, VPR7, VSD7, VSG, VS17, VXE7, WIH1, WKT6
			- - - (1)	2000215	SXP1, VXP

Ref. No.	Part No.	Description	Reqd. QTY				Serial No.	Parts catalogue code
			GX160K1					
			(1)	(2)	(3)	(4)		
(1)	13012-ZL0-003	RING SET, PISTON (0.50) (TEIKOKU)	(1)	(1)	-	-	7603339	AR,ARC6,BL,EMA2,HG12,HH,HHQ4,HH26,HX,HXE,HXE8,HXU,HX2,HX26,HX4 KR,KTA,LD,LH,LHB3,LHQ4,LJ,LJC7,LJG,LJS,LSJ4,LW2,LX,LXU,LX2 LX26,LX4,L1,NJ,NJC1,NJG,NSJ,PHM,PXU,QAB1,QAB3,QAX2,QA2,QA26 QBT6,QCB2,QCL,QD,QE,QFE4,QGR2,QGR9,QH,QHE,QHP1,QHQ4,QH26,QI2 QKA4,QM,QMC6,QMC8,QMD6,QME4,QMH,QMX2,QMZ2,QNT,QNT4,QNZ,QP,QPU QSC2,QSC9,QT,QWA4,QWX2,QX,QXC,QXC6,QXC9,QXE,QXE2,QXE4,QXE6 QXE8,QXF2,QXM1,QXS2,QXU,QXW,QXW2,QX2,QX22,QX26,QX4,RD,RD4,RFR2 RH,RHA2,RHQ4,RH2,RH26,RMB4,RMD,RMG2,RSK,RSS1,RTB2,RX,RXE,RXE4 RXU,RX4,SCJ,SD,SDB3,SDS,SD16,SD4,SE,SG24,SH,SHM,SHQ4,SHRY,SHR4 SJ,SJC1,SJC5,SJG,SKM,SMC7,SMC9,SMJ,SMJ1,SMW2,SMX4,SM11,SM12 SM14,SNX,SNX1,SSK1,SSX2,ST,STM,STQ,SWG4,SWX2,SWX4,SX,SXE,SXE4 SXS4,SXU,SX4,S1CY,TCS2,TX,TXC9,TXU,TX2,TX26,TX4,UH,UX,UXU,VA2 VEBM,VED,VED1,VED2,VED3,VED5,VED6,VGE4,VG24,VHH4,VMB3,VMS4,VMT VPM4,VPR4,VSB1,VSD,VSD1,VSX,VSX1,VSX3,VS3,VS4,VTD,VTU1,VTX1 VWA2,VW12,VX,VXD,VXE4,VXM,VXU,VXU1,VXW2,VX2,VX4,WDA6,WJP,WKD6 WKT2,WKT4,WMB0,WME2,WME4,WMT HXE2,LVL,QBC2,QIH1,QS2,QVL,QX7,RXE2,SX7,VEN2,VES,VHA7,VIH1 VMS7,VPM5,VPM7,VPR7,VSD7,VSG,VS17,VXE7,WIH1,WKT6 SXP1,VXP
	13012-ZL0-004	RING SET, PISTON (0.50) (NIPPON)	(1)	(1)	-	-	7603339	AR,ARC6,BL,EMA2,HG12,HH,HHQ4,HH26,HX,HXE,HXE8,HXU,HX2,HX26,HX4 KR,KTA,LD,LH,LHB3,LHQ4,LJ,LJC7,LJG,LJS,LSJ4,LW2,LX,LXU,LX2 LX26,LX4,L1,NJ,NJC1,NJG,NSJ,PHM,PXU,QAB1,QAB3,QAX2,QA2,QA26 QBT6,QCB2,QCL,QD,QE,QFE4,QGR2,QGR9,QH,QHE,QHP1,QHQ4,QH26,QI2 QKA4,QM,QMC6,QMC8,QMD6,QME4,QMH,QMX2,QMZ2,QNT,QNT4,QNZ,QP,QPU QSC2,QSC9,QT,QWA4,QWX2,QX,QXC,QXC6,QXC9,QXE,QXE2,QXE4,QXE6 QXE8,QXF2,QXM1,QXS2,QXU,QXW,QXW2,QX2,QX22,QX26,QX4,RD,RD4,RFR2 RH,RHA2,RHQ4,RH2,RH26,RMB4,RMD,RMG2,RSK,RSS1,RTB2,RX,RXE,RXE4 RXU,RX4,SCJ,SD,SDB3,SDS,SD16,SD4,SE,SG24,SH,SHM,SHQ4,SHRY,SHR4 SJ,SJC1,SJC5,SJG,SKM,SMC7,SMC9,SMJ,SMJ1,SMW2,SMX4,SM11,SM12 SM14,SNX,SNX1,SSK1,SSX2,ST,STM,STQ,SWG4,SWX2,SWX4,SX,SXE,SXE4 SXS4,SXU,SX4,S1CY,TCS2,TX,TXC9,TXU,TX2,TX26,TX4,UH,UX,UXU,VA2 VEBM,VED,VED1,VED2,VED3,VED5,VED6,VGE4,VG24,VHH4,VMB3,VMS4,VMT VPM4,VPR4,VSB1,VSD,VSD1,VSX,VSX1,VSX3,VS3,VS4,VTD,VTU1,VTX1 VWA2,VW12,VX,VXD,VXE4,VXM,VXU,VXU1,VXW2,VX2,VX4,WDA6,WJP,WKD6 WKT2,WKT4,WMB0,WME2,WME4,WMT HXE2,LVL,QBC2,QIH1,QS2,QVL,QX7,RXE2,SX7,VEN2,VES,VHA7,VIH1 VMS7,VPM5,VPM7,VPR7,VSD7,VSG,VS17,VXE7,WIH1,WKT6 SXP1,VXP



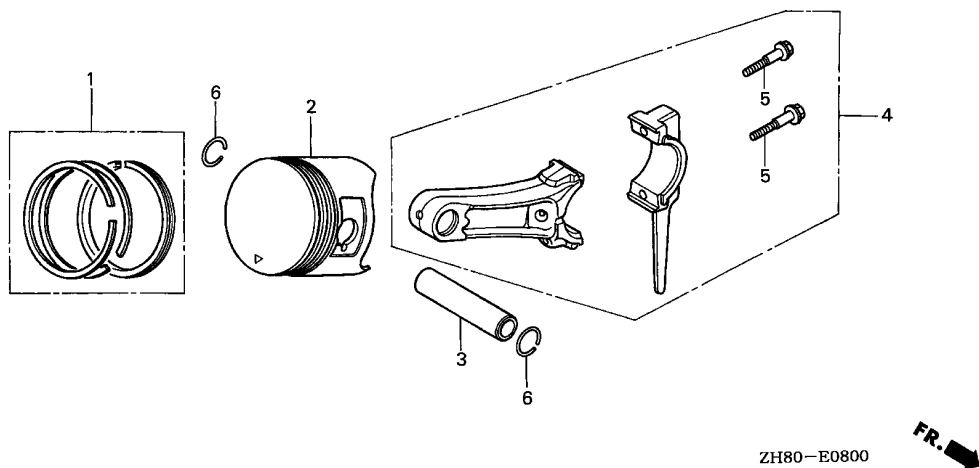

2

Ref. No.	Part No.	Description	Reqd. QTY	Serial No.	Parts catalogue code
			GX160K1 (1) (2) (3) (4)		
(1)	13013-ZL0-003	RING SET, PISTON (0.75) (TEIKOKU)	(1) (1) - -	7603339	AR, ARC6, BL, EMA2, HG12, HH, HHQ4, HH26, HX, HXE, HXE8, HXU, HX2, HX26, HX4, KR, KTA, LD, LH, LHB3, LHQ4, LJ, LJC7, LJG, LJS, LSJ4, LW2, LX, LXU, LX2, LX26, LX4, L1, NJ, NJC1, NJG, NSJ, PHM, PXU, QAB1, QAB3, QAX2, QA2, QA26, QBT6, QCB2, QCL, QD, QE, QFE4, QGR2, QGR9, QH, QHE, QHP1, QHQ4, QH26, QI2, QKA4, QM, QMC6, QMC8, QMD6, QME4, QMH, QMX2, QM22, QNT, QNT4, QNZ, QP, QPU, QSC2, QSC9, QT, QWA4, QWX2, QX, QXC, QXC6, QXC9, QXE, QXE2, QXE4, QXE6, QXE8, QXF2, QXM1, QXS2, QXU, QXW, QXW2, QX2, QX22, QX26, QX4, RD, RD4, RFR2, RH, RHA2, RHQ4, RH2, RH26, RMB4, RMD, RMG2, RSK, RSS1, RTB2, RX, RXE, RXE4, RXU, RX4, SCJ, SD, SDB3, SDS, SD16, SD4, SE, SG24, SH, SHM, SHQ4, SHRY, SHR4, SJ, SJC1, SJC5, SJG, SKM, SMC7, SMC9, SMJ, SMJ1, SMW2, SMX4, SM11, SM12, SM14, SNX, SNX1, SSK1, SSS2, ST, STM, STQ, SWG4, SWX2, SWX4, SX, SXE, SXE4, SXS4, SXU, SX4, S1CY, TCS2, TX, TXC9, TXU, TX2, TX26, TX4, UH, UX, UXU, VA2, VEBM, VED, VED1, VED2, VED3, VED5, VED6, VGE4, VG24, VHH4, VMB3, VMS4, VMT, VPM4, VPR4, VSB1, VSD, VSD1, VSX, VSX1, VSX3, VS3, VS4, VTD, VTU1, VTX1, VWA2, VW12, VX, VXD, VXE4, VXM, VXU, VXU1, VXW2, VX2, VX4, WDA6, WJP, WKD6, WKT2, WKT4, WMBO, WME2, WME4, WMT
			(1) - (1) - -		HXE2, LVL, QBC2, QIH1, QS2, QVL, QX7, RXE2, SX7, VEN2, VES, VHA7, VIH1, VMS7, VPM5, VPM7, VPR7, VSD7, VSG, VS17, VXE7, WIH1, WKT6
			- - - (1)	2000215	SXP1, VXP

Ref. No.	Part No.	Description	Reqd. QTY				Serial No.	Parts catalogue code
			GX160K1					
			(1)	(2)	(3)	(4)		
(1)	13013-ZL0-004	RING SET, PISTON (0.75)	(1)	(1)	-	-	7603339	AR,ARC6,BL,EMA2,HG12,HH,HHQ4,HH26,HX,HXE,HXE8,HXU,HX2,HX26,HX4 KR,KTA,LD,LH,LHB3,LHQ4,LJ,LJC7,LJG,LJS,LSJ4,LW2,LX,LXU,LX2 LX26,LX4,L1,NJ,NJC1,NJG,NSJ,PHM,PXU,QAB1,QAB3,QAX2,QA2,QA26 QBT6,QCB2,QCL,QD,QE,QFE4,QGR2,QGR9,QH,QHE,QHP1,QHQ4,QH26,QI2 QKA4,QM,QMC6,QMC8,QMD6,QME4,QMH,QMX2,QMZ2,QNT,QNT4,QNZ,QP,QPU QSC2,QSC9,QT,QWA4,QWX2,QX,QXC,QXC6,QXC9,QXE,QXE2,QXE4,QXE6 QXE8,QXF2,QXM1,QXS2,QXU,QXW,QXW2,QX2,QX22,QX26,QX4,RD,RD4,RFR2 RH,RHA2,RHQ4,RH2,RH26,RMB4,RMD,RMG2,RSK,RSS1,RTB2,RX,RXE,RXE4 RXU,RX4,SCJ,SD,SDB3,SDS,SD16,SD4,SE,SG24,SH,SHM,SHQ4,SHRY,SHR4 SJ,SJC1,SJC5,SJG,SKM,SMC7,SMC9,SMJ,SMJ1,SMW2,SMX4,SM11,SM12 SM14,SNX,SNX1,SSK1,SSX2,ST,STM,STQ,SWG4,SWX2,SWX4,SX,SXE,SXE4 SXS4,SXU,SX4,S1CY,TCS2,TX,TXC9,TXU,TX2,TX26,TX4,UH,UX,UXU,VA2 VEBM,VED,VED1,VED2,VED3,VED5,VED6,VGE4,VG24,VHH4,VMB3,VMS4,VMT VPM4,VPR4,VSB1,VSD,VSD1,VSX,VSX1,VSX3,VS3,VS4,VTD,VTU1,VTX1 VWA2,VW12,VX,VXD,VXE4,VXM,VXU,VXU1,VXW2,VX2,VX4,WDA6,WJP,WKD6 WKT2,WKT4,WMB0,WME2,WME4,WMT HXE2,LVL,QBC2,QIH1,QS2,QVL,QX7,RXE2,SX7,VEN2,VES,VHA7,VIH1 VMS7,VPM5,VPM7,VPR7,VSD7,VSG,VS17,VXE7,WIH1,WKT6
2	13101-ZF1-010	PISTON (STD.)	1	-	-	(1)	2000215	SXP1,VXP PM,QZ
	13101-ZF1-020		1	-	-	-	7603338	QM,QT,SNX,SNX1
	13101-ZF1-901		1	-	1	-	7603339	QM,QT,SNX,SNX1
	13101-ZF1-902		-	-	1	-		QIH1
	13101-ZH8-000		1	1	-	1		LTA,SDN,UIH WIH1
			1	1	-	-	7603338	DS,DSP,EMA,EN,ET,ETX,HG1,HXQ,H1,LAX,LAX2,LDB1,LDB3,LDM,LD4,LHW LJD,LMT,LSJ,LSS,LSS1,LSS4,LTK,NW,PH,PHU,PM2,PX,PX2,QA,QAX,QBT2 QBU2,QNT2,QWM2,QWX3,QXB,QXB1,QXF,QXQ,QXS,Q1,RAC,REX4,RFR,RHA RNG,R1,SAC,SAD2,SDB1,SDS2,SDS3,SEE,SJC,SMB4,SSK2,STA,STP,SWX SW2,SXB,S1,TH,THU,T1,U1,VA,VEB2,VED7,VH,VHQ4,VS,VSDP,VSW,VS1 VTD1,VTE2,VTX,VWA,VXD1,VXE,VXE6,VXG,VXW,VXW1,VX26,V1,W1 AR,ARC6,BL,EMA2,HG12,HH,HHQ4,HH26,HX,HXE,HXE8,HXU,HX2,HX26,HX4 KR,KTA,LD,LH,LHB3,LHQ4,LJ,LJC7,LJG,LJS,LSJ4,LW2,LX,LXU,LX2 LX26,LX4,L1,NJ,NJC1,NJG,NSJ,PHM,PXU,QAB1,QAB3,QAX2,QA2,QA26 QBT6,QCB2,QCL,QD,QE,QFE4,QGR2,QGR9,QH,QHE,QHP1,QHQ4,QH26,QI2 QKA4,QMC6,QMC8,QMD6,QME4,QMH,QMX2,QMZ2,QNT,QNT4,QNZ,QP,QPU QSC2,QSC9,QWA4,QWX2,QX,QXC,QXC6,QXC9,QXE,QXE2,QXE4,QXE6,QXE8 QXF2,QXM1,QXS2,QXU,QXW,QXW2,QX2,QX22,QX26,QX4,RD,RD4,RFR2,RH RHA2,RHQ4,RH2,RH26,RMB4,RMD,RMG2,RSK,RSS1,RTB2,RX,RXE,RXE4,RXU RX4,SCJ,SD,SDB3,SDS,SD16,SD4,SE,SG24,SH,SHM,SHQ4,SHRY,SHR4,SJ SJC1,SJC5,SJG,SKM,SMC7,SMC9,SMJ,SMJ1,SMW2,SMX4,SM11,SM12,SM14 SSK1,SSX2,ST,STM,STQ,SWG4,SWX2,SWX4,SX,SXE,SXE4,SXS4,SXU,SX4 S1CY,TCS2,TX,TXC9,TXU,TX2,TX26,TX4,UH,UX,UXU,VA2,VEBM,VED,VED1 VED2,VED3,VED5,VED6,VGE4,VG24,VHH4,VMB3,VMS4,VMT,VPM4,VPR4 VSB1,VSD,VSD1,VSX,VSX1,VSX3,VS3,VS4,VTD,VTU1,VTX1,VWA2,VW12,VX VXD,VXE4,VXM,VXU1,VXW2,VX2,VX4,WDA6,WJP,WKD6,WKT2,WKT4 WMB0,WME2,WME4,WMT
			-	-	-	1	2000214	SXP1,VXP



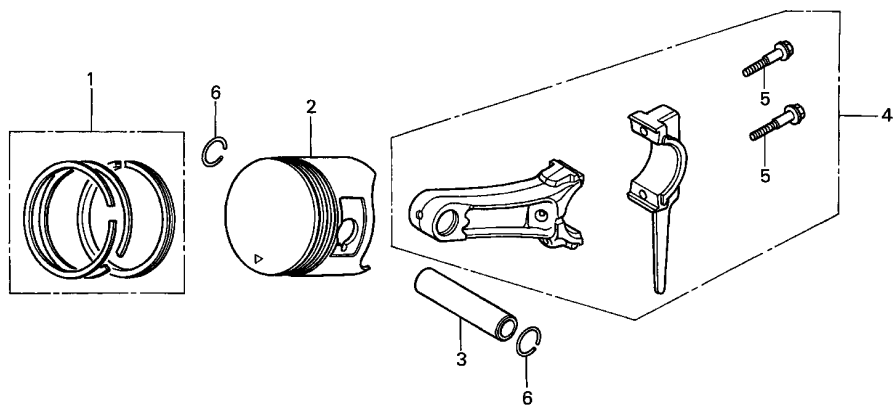

ZH80-E0800



Ref. No.	Part No.	Description	Reqd. QTY				Serial No.	Parts catalogue code
			(1)	(2)	(3)	(4)		
(2)	13101-ZH8-010	PISTON (STD.)	1	1	-	-	7603339	AR,ARC6,BL,EMA2,HG12,HH,HHQ4,HH26,HX,HXE,HXE8,HXU,HX2,HX26,HX4 KR,KTA,LD,LH,LHB3,LHQ4,LJ,LJC7,LJG,LJS,LSJ4,LW2,LX,LXU,LX2 LX26,LX4,L1,NJ,NJC1,NJG,NSJ,PHM,PXU,QAB1,QAB3,QAX2,QA2,QA26 QBT6,QCB2,QCL,QD,QE,QFE4,QGR2,QGR9,QH,QHE,QHP1,QHQ4,QH26,QI2 QKA4,QMC6,QMC8,QMD6,QME4,QMH,QMX2,QMZ2,QNT,QNT4,QNZ,QP,QPU QSC2,QSC9,QWA4,QWX2,QX,QXC,QXC6,QXC9,QXE,QXE2,QXE4,QXE6,QXE8 QXF2,QXM1,QXS2,QXU,QXW,QXW2,QX2,QX22,QX26,QX4,RD,RD4,RFR2,RH RHA2,RHQ4,RH2,RH26,RMB4,RMD,RMG2,RSK,RSS1,RTB2,RX,RXE,RXE4,RXU RX4,SCJ,SD,SDB3,SDS,SD16,SD4,SE,SG24,SH,SHM,SHQ4,SHRY,SHR4,SJ SJC1,SJC5,SJG,SKM,SMC7,SMC9,SMJ,SMJ1,SMW2,SMX4,SM11,SM12,SM14 SSK1,SSX2,ST,STM,STQ,SWG4,SWX2,SWX4,SX,SXE,SXE4,SXS4,SXU,SX4 S1CY,TCS2,TX,TXC9,TXU,TX2,TX26,TX4,UH,UX,UXU,VA2,VEBM,VED,VED1 VED2,VED3,VED5,VED6,VGE4,VG24,VHH4,VMB3,VMS4,VMT,VPM4,VPR4 VSB1,VSD,VSD1,VSX,VSX1,VSX3,VS3,VS4,VTD,VTU1,VTX1,VWA2,VW12,VX VXD,VXE4,VXM,VXU,VXU1,VXW2,VX2,VX4,WDA6,WJP,WKD6,WKT2,WKT4 WMB0,WME2,WME4,WMT
			1	-	1	-		HXE2,LVL,QBC2,QS2,QVL,QX7,RXE2,SX7,VEN2,VES,VHA7,VIH1,VMS7 VPM5,VPM7,VPR7,VSD7,VSG,VS17,VXE7,WKT6
	13102-ZF1-010	PISTON (0.25)	-	-	-	1	2000215	SXP1,VXP
			(1)	-	-	-		PM,QZ
			(1)	-	-	-	7603338	QM,QT
			(1)	-	-	5495900	7603338	SNX,SNX1
	13102-ZF1-020		(1)	-	-	7603339		QM,QT,SNX,SNX1
			-	-	(1)	-		QIH1
	13102-ZF1-901		(1)	-	(1)	-		LTA,SDN,UIH
	13102-ZF1-902		-	-	(1)	-		WIH1

Ref. No.	Part No.	Description	Reqd. QTY				Serial No.	Parts catalogue code
			GX160K1					
			(1)	(2)	(3)	(4)		
(2)	13102-ZH8-000	PISTON (0.25)	(1)	(1)	-	(1)	DS,DSP,EMA,EN,ET,ETX,HG1,HXQ,H1,LAX,LAX2,LDB1,LDB3,LDM,LD4,LHW LJD,LMT,LSJ,LSS,LSS1,LSS4,LTK,NW,PH,PHU,PM2,PX,FX2,QA,QAX,QBT2 QBU2,QNT2,QWM2,QWX3,QXB,QXB1,QXF,QXQ,QXS,Q1,RAC,REX4,RFR,RHA RNG,R1,SAC,SAD2,SDB1,SDS2,SDS3,SEE,SJC,SMB4,SSK2,STA,STP,SWX SW2,SXB,S1,TH,THU,T1,U1,VA,VEB2,VED7,VH,VHQ4,VS,VSDP,VSW,VS1 VTD1,VTE2,VTX,VWA,VXD1,VXE,VXE6,VXG,VXW,VXW1,VX26,V1,W1 AR,ARC6,BL,EMA2,HG12,HH,HHQ4,HH26,HX,HXE,HXE8,HXU,HX2,HX26,HX4 KR,KTA,LD,LH,LHB3,LHQ4,LJ,LJC7,LJG,LJS,LSJ4,LW2,LX,LXU,LX2 LX26,LX4,L1,NJ,NJC1,NJG,NSJ,PHM,PXU,QAB1,QAB3,QAX2,QA2,QA26 QBT6,QCB2,QCL,QD,QE,QFE4,QGR2,QGR9,QH,QHE,QHP1,QHQ4,QH26,QI2 QKA4,QMC6,QMC8,QMD6,QME4,QMH,QMX2,QMZ2,QNT,QNT4,QNZ,QP,QPU QSC2,QSC9,QWA4,QWX2,QX,QXC,QXC6,QXC9,QXE,QXE2,QXE4,QXE6,QXE8 QXF2,QXM1,QXS2,QXU,QXW,QXW2,QX2,QX22,QX26,QX4,RD,RD4,RFR2,RH RHA2,RHQ4,RH2,RH26,RMB4,RMD,RMG2,RSK,RSS1,RTB2,RX,RXE,RXE4,RXU RX4,SCJ,SD,SDB3,SDS,SD16,SD4,SE,SG24,SH,SHM,SHQ4,SHRY,SHR4,SJ SJC1,SJC5,SJG,SKM,SMC7,SMC9,SMJ,SMJ1,SMW2,SMX4,SM11,SM12,SM14 SSK1,SSX2,ST,STM,STQ,SWG4,SWX2,SWX4,SX,SXE,SXE4,SXS4,SXU,SW4 S1CY,TCS2,TX,TXC9,TXU,TX2,TX26,TX4,UH,UX,UXU,VA2,VEBM,VED,VED1 VED2,VED3,VED5,VED6,VGE4,VG24,VHH4,VMB3,VMS4,VMT,VPM4,VPR4 VSB1,VSD,VSD1,VSX,VSX1,VSX3,VS3,VS4,VTD,VTU1,VTX1,VWA2,VW12,VX VXD,VXE4,VXM,VXU,VXU1,VXW2,VX2,VX4,WDA6,WJP,WKD6,WKT2,WKT4 WMBO,WME2,WME4,WMT SNX,SNX1 SXP1,VXP	
	13102-ZH8-010		(1)	(1)	-	(1)	5495899 2000214 7603339	
	13103-ZF1-010	PISTON (0.50)	(1)	(1)	-	(1)	AR,ARC6,BL,EMA2,HG12,HH,HHQ4,HH26,HX,HXE,HXE8,HXU,HX2,HX26,HX4 KR,KTA,LD,LH,LHB3,LHQ4,LJ,LJC7,LJG,LJS,LSJ4,LW2,LX,LXU,LX2 LX26,LX4,L1,NJ,NJC1,NJG,NSJ,PHM,PXU,QAB1,QAB3,QAX2,QA2,QA26 QBT6,QCB2,QCL,QD,QE,QFE4,QGR2,QGR9,QH,QHE,QHP1,QHQ4,QH26,QI2 QKA4,QMC6,QMC8,QMD6,QME4,QMH,QMX2,QMZ2,QNT,QNT4,QNZ,QP,QPU QSC2,QSC9,QWA4,QWX2,QX,QXC,QXC6,QXC9,QXE,QXE2,QXE4,QXE6,QXE8 QXF2,QXM1,QXS2,QXU,QXW,QXW2,QX2,QX22,QX26,QX4,RD,RD4,RFR2,RH RHA2,RHQ4,RH2,RH26,RMB4,RMD,RMG2,RSK,RSS1,RTB2,RX,RXE,RXE4,RXU RX4,SCJ,SD,SDB3,SDS,SD16,SD4,SE,SG24,SH,SHM,SHQ4,SHRY,SHR4,SJ SJC1,SJC5,SJG,SKM,SMC7,SMC9,SMJ,SMJ1,SMW2,SMX4,SM11,SM12,SM14 SSK1,SSX2,ST,STM,STQ,SWG4,SWX2,SWX4,SX,SXE,SXE4,SXS4,SXU,SW4 S1CY,TCS2,TX,TXC9,TXU,TX2,TX26,TX4,UH,UX,UXU,VA2,VEBM,VED,VED1 VED2,VED3,VED5,VED6,VGE4,VG24,VHH4,VMB3,VMS4,VMT,VPM4,VPR4 VSB1,VSD,VSD1,VSX,VSX1,VSX3,VS3,VS4,VTD,VTU1,VTX1,VWA2,VW12,VX VXD,VXE4,VXM,VXU,VXU1,VXW2,VX2,VX4,WDA6,WJP,WKD6,WKT2,WKT4 WMBO,WME2,WME4,WMT HXE2,LVL,QBC2,QS2,QVL,QX7,RXE2,SX7,VEN2,VES,VHA7,VIH1,VMS7 VPM5,VPM7,VPR7,VSD7,VSG,VS17,VXE7,WKT6 SXP1,VXP PM,QZ QM,QT 7603338 5495900 7603338 7603339	
	13103-ZF1-020		(1)	(1)	-	(1)	7603339	
	13103-ZF1-901		(1)	(1)	-	(1)	QI1	
	13103-ZF1-902		(1)	(1)	-	(1)	LTA,SDN,UIH WIH1	



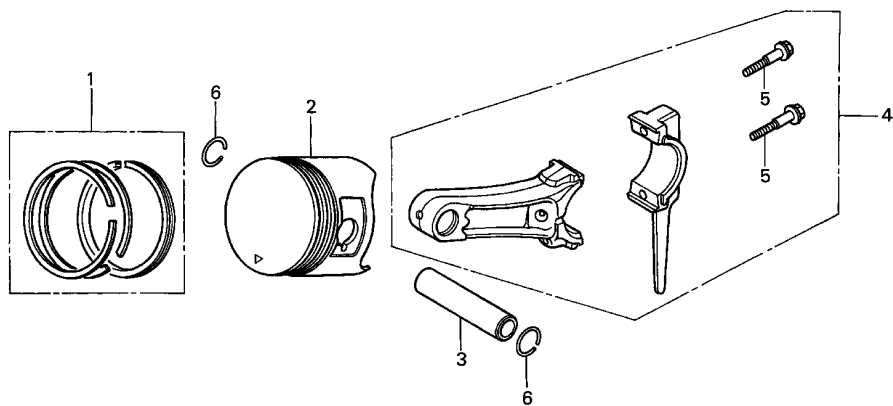

ZH80-E0800



Ref. No.	Part No.	Description	Reqd. QTY				Serial No.	Parts catalogue code
			(1)	(2)	(3)	(4)		
			GX160K1					
(2)	13103-ZH8-000	PISTON (0.50)	(1)	(1)	-	(1)	-----	DS,DSP,EMA,EN,ET,ETX,HG1,HXQ,H1,LAX,LAX2,LDB1,LDB3,LDM,LD4,LHW,LJD,LMT,LSJ,LSS,LSS1,LSS4,LTK,NW,PH,PHU,PM2,PX,PX2,QA,QAX,QBT2,QBU2,QNT2,QWM2,QWX3,QXB,QXB1,QXF,QXQ,QXS,Q1,RAC,REX4,RFR,RHARNG,R1,SAC,SAD2,SDB1,SDS2,SDS3,SEE,SJC,SMB4,SSK2,STA,STP,SWX,SW2,SXB,S1,TH,THU,T1,U1,VA,VEB2,VED7,VH,VHQ4,VS,VSDP,VSW,VS1,VTD1,VTE2,VTX,VWA,VXD1,VXE,VXE6,VXG,VXW,VXW1,VX26,V1,W1
			(1)	(1)	-	-	-----	7603338 AR,ARC6,BL,EMA2,HG12,HH,HHQ4,HH26,HX,HXE,HXE8,HXU,HX2,HX26,HX4,KR,KTA,LD,LH,LHB3,LHQ4,LJ,LJC7,LJG,LJS,LSJ4,LW2,LX,LXU,LX2,LX26,LX4,L1,NJ,NJC1,NJG,NSJ,PHM,PXU,QAB1,QAB3,QAX2,QA2,QA26,QBT6,QCB2,QCL,QD,QE,QFE4,QGR2,QGR9,QH,QHE,QHP1,QHQ4,QH26,QI2,QKA4,QMC6,QMC8,QMD6,QME4,QMH,QMX2,QMZ2,QNT,QNT4,QNZ,QP,QPU,QSC2,QSC9,QWA4,QWX2,QX,QXC,QXC6,QXC9,QXE,QXE2,QXE4,QXE6,QXE8,QXF2,QXM1,QXS2,QXU,QXW,QXW2,QX2,QX22,QX26,QX4,RD,RD4,RFR2,RH,RHA2,RHQ4,RH2,RH26,RMB4,RMD,RMG2,RSK,RSS1,RTB2,RX,RXE,RXE4,RXU,RX4,SCJ,SD,SDB3,SDS,SD16,SD4,SE,SG24,SH,SHM,SHQ4,SHRY,SHR4,SJ,SJC1,SJC5,SJG,SKM,SMC7,SMC9,SMJ,SMJ1,SMW2,SMX4,SM11,SM12,SM14,SSK1,SSX2,ST,STM,STQ,SWG4,SWX2,SWX4,SX,SXE,SXE4,SXS4,SXU,SX4,S1CY,TCS2,TX,TXC9,TXU,TX2,TX26,TX4,UH,UX,UXU,VA2,VEBM,VED,VED1,VED2,VED3,VED5,VED6,VGE4,VG24,VHH4,VMB3,VMS4,VMT,VPM4,VPR4,VSB1,VSD,VSD1,VSX,VSX1,VSX3,VS3,VS4,VTD,VTU1,VTX1,VWA2,VW12,VX,VXD,VXE4,VXM,VXU,VXU1,VXW2,VX2,VX4,WDA6,WJP,WKD6,WKT2,WKT4,WMB0,WME2,WME4,WMT
			(1)	-	-	-	-----	5495899 SNX,SNX1
			-	-	-	(1)	-----	2000214 SXP1,VXP

Ref. No.	Part No.	Description	Reqd. QTY				Serial No.	Parts catalogue code
			GX160K1					
			(1)	(2)	(3)	(4)		
(2)	13103-ZH8-010	PISTON (0.50)	(1)	(1)	-	-	7603339	AR,ARC6,BL,EMA2,HG12,HH,HHQ4,HH26,HX,HXE,HXE8,HXU,HX2,HX26,HX4 KR,KTA,LD,LH,LHB3,LHQ4,LJ,LJC7,LJG,LJS,LSJ4,LW2,LX,LXU,LX2 LX26,LX4,L1,NJ,NJC1,NJG,NSJ,PHM,PXU,QAB1,QAB3,QAX2,QA2,QA26 QBT6,QCB2,QCL,QD,QE,QFE4,QGR2,QGR9,QH,QHE,QHP1,QHQ4,QH26,QI2 QKA4,QMC6,QMC8,QMD6,QME4,QMH,QMX2,QMZ2,QNT,QNT4,QNZ,QP,QPU QSC2,QSC9,QWA4,QWX2,QX,QXC,QXC6,QXC9,QXE,QXE2,QXE4,QXE6,QXE8 QXF2,QXM1,QXS2,QXU,QXW,QXW2,QX2,QX22,QX26,QX4,RD,RD4,RFR2,RH RHA2,RHQ4,RH2,RH26,RMB4,RMD,RMG2,RSK,RSS1,RTB2,RX,RXE,RXE4,RXU RX4,SCJ,SD,SDB3,SDS,SD16,SD4,SE,SG24,SH,SHM,SHQ4,SHRY,SHR4,SJ SJC1,SJC5,SJG,SKM,SMC7,SMC9,SMJ,SMJ1,SMW2,SMX4,SM11,SM12,SM14 SSK1,SSX2,ST,STM,STQ,SWG4,SWX2,SWX4,SX,SXE,SXS4,SXU,SX4 S1CY,TCS2,TX,TXC9,TXU,TX2,TX26,TX4,UH,UX,UXU,VA2,VEBM,VED,VED1 VED2,VED3,VED5,VED6,VGE4,VG24,VHH4,VMB3,VMS4,VMT,VPM4,VPR4 VSB1,VSD,VSD1,VSX,VSX1,VSX3,VS3,VS4,VTD,VTU1,VTX1,VWA2,VW12,VX VXD,VXE4,VXM,VXU,VXU1,VXW2,VX2,VX4,WDA6,WJP,WKD6,WKT2,WKT4 WMB0,WME2,WME4,WMT
			(1)	-	(1)	-	2000215	HXE2,LVL,QBC2,QS2,QVL,QX7,RXE2,SX7,VEN2,VES,VHA7,VIH1,VMS7 VPM5,VPM7,VPR7,VSD7,VSG,VS17,VXE7,WKT6
	13104-ZF1-010	PISTON (0.75)	(1)	-	-	(1)	2000215	SXP1,VXP
			(1)	-	-	-	5495900	PM,QM,QT,QZ,VED7
	13104-ZF1-020		(1)	-	-	-	7603338	SNX,SNX1
			(1)	-	-	-	7603339	RMD,RSS1,SNX,SNX1,VED3
	13104-ZF1-901		-	-	(1)	-		QIH1
	13104-ZF1-902		(1)	-	(1)	-		LTA,SDN,UIH
	13104-ZH8-000		-	-	(1)	-		WIH1
			(1)	(1)	-	(1)		DS,DSP,EMA,EN,ET,ETX,HG1,HXQ,H1,LAX,LAX2,LDB1,LDB3,LDM,LD4,LHW LJD,LMT,LSJ,LSS,LSS1,LSS4,LTK,NW,PH,PHU,PM2,PX,PX2,QA,QAX,QBT2 QBU2,QNT2,QWM2,QWX3,QXB,QXB1,QXF,QXQ,QXS,Q1,RAC,REX4,RFR,RHA RNG,R1,SAC,SAD2,SDB1,SDS2,SDS3,SEE,SJC,SMB4,SSK2,STA,STP,SW SW2,SXB,S1,TH,THU,T1,U1,VA,VEB2,VED7,VH,VHQ4,VS,VSDP,VSU1 VTD1,VTX,VWA,VXD1,VXE,VXE6,VXG,VXW,VXW1,VX26,V1,W1
			(1)	(1)	-	-	7603338	AR,ARC6,BL,EMA2,HG12,HH,HHQ4,HH26,HX,HXE,HXE8,HXU,HX2,HX26,HX4 KR,KTA,LD,LH,LHB3,LHQ4,LJ,LJC7,LJG,LJS,LSJ4,LW2,LX,LXU,LX2 LX26,LX4,L1,NJ,NJC1,NJG,NSJ,PHM,PXU,QAB1,QAB3,QAX2,QA2,QA26 QBT6,QCB2,QCL,QD,QE,QFE4,QGR2,QGR9,QH,QHE,QHP1,QHQ4,QH26,QI2 QKA4,QMC6,QMC8,QMD6,QME4,QMH,QMX2,QMZ2,QNT,QNT4,QNZ,QP,QPU QSC2,QSC9,QWA4,QWX2,QX,QXC,QXC6,QXC9,QXE,QXE2,QXE4,QXE6,QXE8 QXF2,QXM1,QXS2,QXU,QXW,QXW2,QX2,QX22,QX26,QX4,RD,RD4,RFR2,RH RHA2,RHQ4,RH2,RH26,RMB4,RMD,RMG2,RSK,RSS1,RTB2,RX,RXE,RXE4,RXU RX4,SCJ,SD,SDB3,SDS,SD16,SD4,SE,SG24,SH,SHM,SHQ4,SHRY,SHR4,SJ SJC1,SJC5,SJG,SKM,SMC7,SMC9,SMJ,SMJ1,SMW2,SMX4,SM11,SM12,SM14 SSK1,SSX2,ST,STM,STQ,SWG4,SWX2,SWX4,SX,SXE,SXS4,SXU,SX4 S1CY,TCS2,TX,TXC9,TXU,TX2,TX26,TX4,UH,UX,UXU,VA2,VEBM,VED,VED1 VED2,VED3,VED5,VED6,VGE4,VG24,VHH4,VMB3,VMS4,VMT,VPM4,VPR4 VSB1,VSD,VSD1,VSX,VSX1,VSX3,VS3,VS4,VTD,VTU1,VTX1,VWA2,VW12,VX VXD,VXE4,VXM,VXU,VXU1,VXW2,VX2,VX4,WDA6,WJP,WKD6,WKT2,WKT4 WMB0,WME2,WME4,WMT
			(1)	-	-	-	5495899	SNX,SNX1
			-	-	-	(1)	2000214	SXP1,VXP



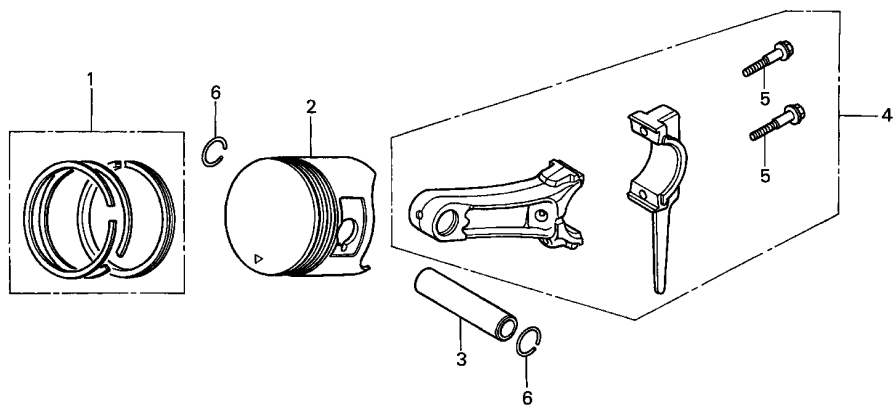

ZH80-E0800



2

Ref. No.	Part No.	Description	Reqd. QTY				Serial No.	Parts catalogue code
			(1)	(2)	(3)	(4)		
			GX160K1					
			(1)	(2)	(3)	(4)		
(2)	13104-ZH8-010	PISTON (0.75)	(1)	(1)	-	-	7603339	AR,ARC6,BL,EMA2,HG12,HH,HHQ4,HH26,HX,HXE,HXE8,HXU,HX2,HX26,HX4 KR,KTA,LD,LH,LHB3,LHQ4,LJ,LJC7,LJG,LJS,LSJ4,LW2,LX,LXU,LX2 LX26,LX4,L1,NJ,NJC1,NJG,NSJ,PHM,PXU,QAB1,QAB3,QAX2,QA2,QA26 QBT6,QCB2,QCL,QD,QE,QFE4,QGR2,QGR9,QH,QHE,QHP1,QHQ4,QH26,QI2 QKA4,QMC6,QMC8,QMD6,QME4,QMH,QMX2,QMZ2,QNT,QNT4,QNZ,QP,QPU QSC2,QSC9,QWA4,QWX2,QX,QXC,QXC6,QXC9,QXE,QXE2,QXE4,QXE6,QXE8 QXF2,QXM1,QXS2,QXU,QXW,QXW2,QX2,QX22,QX26,QX4,RD,RD4,RFR2,RH RHA2,RHQ4,RH2,RH26,RMB4,RMD,RMG2,RSK,RSS1,RTB2,RX,RXE,RXE4,RXU RX4,SCJ,SD,SDB3,SDS,SD16,SD4,SE,SG24,SH,SHM,SHQ4,SHRY,SHR4,SJ SJC1,SJC5,SJG,SKM,SMC7,SMC9,SMJ,SMJ1,SMW2,SMX4,SM11,SM12,SM14 SSK1,SSX2,ST,STM,STQ,SWG4,SWX2,SWX4,SX,SXE,SXE4,SXS4,SXU,SX4 S1CY,TCS2,TX,TXC9,TXU,TX2,TX26,TX4,UH,UX,UXU,VA2,VEBM,VED,VED1 VED2,VED3,VED5,VED6,VGE4,VG24,VHH4,VMB3,VMS4,VMT,VPM4,VPR4 VSB1,VSD,VSD1,VSX,VSX1,VSX3,VS3,VS4,VTD,VTU1,VTX1,VWA2,VW12,VX VXD,VXE4,VXM,VXU1,VXW2,VX2,VX4,WDA6,WJP,WKD6,WKT2,WKT4 WMB0,WME2,WME4,WMT (1) - (1) - - - - - HXE2,LVL,QBC2,QS2,QVL,QX7,RXE2,SX7,VEN2,VES,VHA7,VIH1,VMS7 VPM5,VPM7,VPR7,VSD7,VSG,VS17,VXE7,WKT6 SXP1,VXP
3	13111-ZE1-000	PIN, PISTON	1	1	1	1		
4	13200-ZE1-010	ROD ASSY., CONNECTING (STD.)	1	1	1	1		

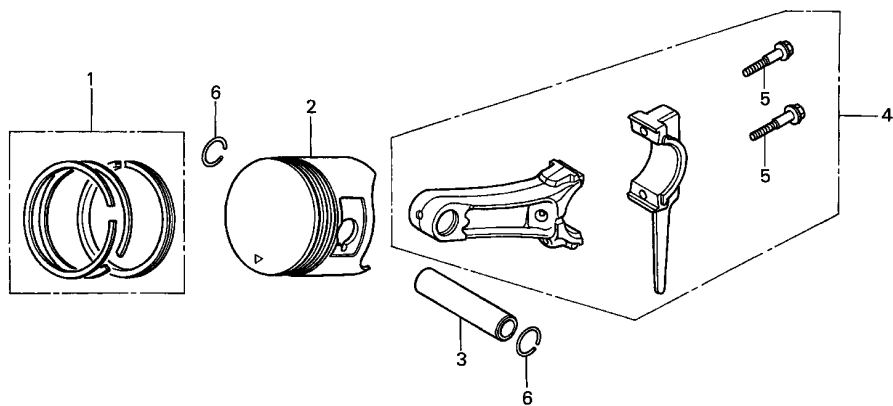

ZH80-E0800



Ref. No.	Part No.	Description	Reqd. QTY				Serial No.	Parts catalogue code
			(1)	(2)	(3)	(4)		
(4)	132A0-ZE1-000	ROD ASSY., CONNECTING (0.25 UNDER SIZE)	(1)	-	-	-	-----	ARC6,DS,DSP,EMA,EN,ET,ETX,HG1,HH,HHQ4,HH26,HX,HXE,HXE8,HXQ,HXU HX2,HX26,HX4,KR,KTA,LAX,LD,LDB1,LDB3,LDM,LD4,LH,LHB3,LHQ4,LHW LJ,LJC7,LJD,LJG,LJS,LMT,LSJ,LSJ4,LSS,LSS1,LSS4,LTA,LTK,LVL,LW2 LX,LXU,LX2,LX26,LX4,NJ,NJC1,NJG,NSJ,NW,PH,PHM,PHU,PM,PM2,FX PXU,PX2,QA,QAB1,QAB3,QAX,QA2,QA26,QBT6,QBU2,QD,QE,QFE4,QGR2,QH QHE,QHP1,QHQ4,QH26,QKA4,QM,QMC6,QMC8,QMD6,QME4,QMH,QNT,QNT2 QNT4,QNZ,QP,QPU,QT,QVL,QWA4,QX,QXB,QXB1,QXC,QXC6,QXE,QXE2,QXE4 QXE6,QXE8,QXF,QXF2,QXM1,QXQ,QXS,QXS2,QXU,QXW,QXW2,QX2,QX26,QX4 QZ,RAC,RD,RD4,REX4,RFRR,RH,RHA,RHQ4,RH2,RH26,RMB4,RMD,RNG,RSK RSS1,RX,RXE,RXE4,RXU,RX4,SAC,SAD2,SCJ,SD,SDB1,SDB3,SDN,SDS SDS2,SDS3,SD16,SD4,SE,SEE,SH,SHM,SHQ4,SHR4,SJ,SJC,SJC5,SJG,SKM SMB4,SMC7,SMC9,SMJ,SMJ1,SM14,SNX,SNX1,SSK1,ST,STA,STM,STP,STQ SWG4,SWX,SW2,SX,SXB,SXE,SXE4,SXS4,SXU,SX4,TH,THU,TX,TXU,TX2 TX26,TX4,UH,UX,UXU,VA,VEBM,VED,VED1,VED2,VED3,VED5,VES,VGE4,VH VHH4,VHQ4,VMB3,VMS4,VPM4,VPM7,VPR4,VPR7,VS,VS1,VSD,VSD1,VSW VSX,VSX1,VSX3,VS1,VS17,VS3,VS4,VTD,VTD1,VTE2,VTU1,VTX,VTX1,VWA VX,VXD,VXD1,VXE,VXE4,VXE6,VXG,VXM,VXU,VXU1,VXW,VXW1,VXW2,VX2 VX26,VX4,WDA6,WJP,WKT2,WKT4,WKT6,WMB0,WME4,WMT
5	90001-ZE1-000	BOLT, CONNECTING ROD	-	(1)	(1)	(1)		
6	90551-ZE1-000	CLIP, PISTON PIN, 18MM	2	2	2	2		



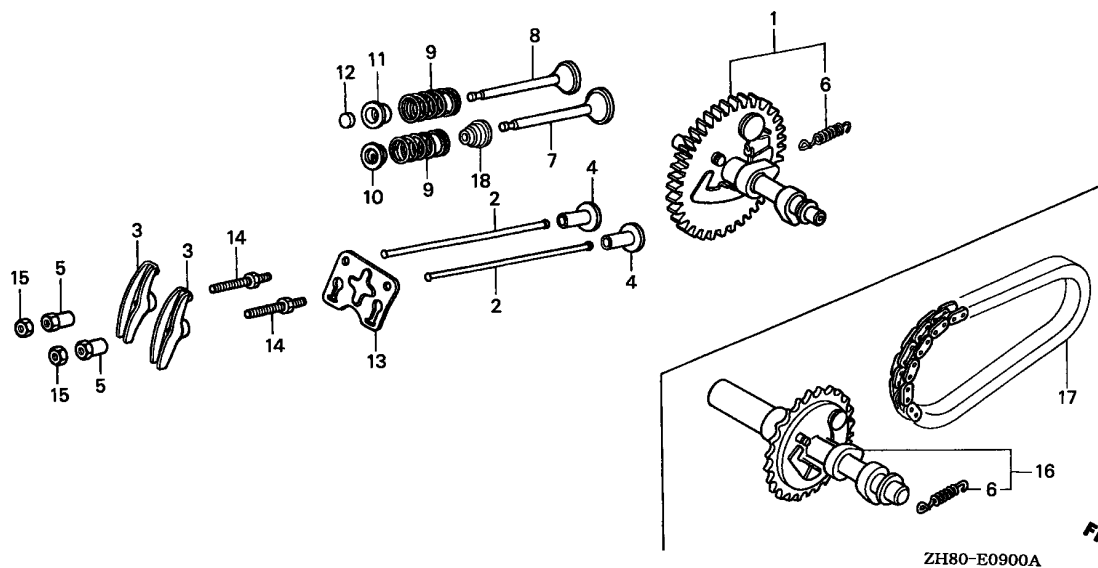

Ref. No.	L.O.N.	(Relative ref. Number) Description	F.R.T.
1	1111C2	(16) CAMSHAFTINCLUDES: Valve clearance adjustment	0.4
2	1111L6	ROD, PUSH :INTAKEINCLUDES: Valve clearance adjustment	0.2
	1111L6A	.For two add	0.1
	1111L7	ROD, PUSH :EXHAUSTINCLUDES: Valve clearance adjustment	0.2
	1111L7A	.For two add	0.1
3	1111A2	ARM, ROCKER :INTAKEINCLUDES: Valve clearance adjustment	0.2
	1111A2A	.With exhaust rocker arm add ..	0.1
	1111A1	ARM, ROCKER :EXHAUSTINCLUDES: Valve clearance adjustment	0.2
	1111A1A	.With intake rocker arm add ..	0.1
4	1111L9	LIFTER, VALVE :INTAKENOTE: Same time for two units	0.4
	1111M0	LIFTER, VALVE :EXHAUSTNOTE: Same time for two units	0.4
+	7	1111L1 VALVE, INTAKE	0.7

Ref. No.	Part No.	Description	Reqd. QTY				Serial No.	Parts catalogue code
			(1)	(2)	(3)	(4)		
1	14100-ZE1-812	CAMSHAFT ASSY.	1	-	-	-	BL,DS,DSP,EMA,EN,ET,ETX,HG1,HG12,HH,HHQ4,HH26,HX,HXE,HXE2,HXE8,HXQ,HXU,HX2,HX26,HX4,KTA,LAX,LAX2,LD,LDB1,LDB3,LDM,LD4,LH,LHB3,LHQ4,LHW,LJC7,LJD,LJG,LJS,LMT,LSJ,LSJ4,LSS,LSS1,LSS4,LTK,LVL,LW2,LX,LXU,LX2,LX26,LX4,PH,PHM,PHU,PM2,PX,PXU,PX2,QA,QAB1,QAB3,QAX,QAX2,QA2,QA26,QBC2,QBT2,QBT6,QBU2,QCB2,QD,QE,QFE4,QGR2,QGR9,QH,QHE,QHP1,QHQ4,QH26,QI2,QKA4,QMC6,QMC8,QMD6,QME4,QMH,QMX2,QMZ2,QNT,QNT2,QNT4,QNZ,QP,QPU,QSC2,QSC9,QS2,QVL,QWA4,QWM2,QWX2,QWX3,QX,QXB,QXB1,QXC,QXC6,QXC9,QXE,QXE2,QXE4,QXE6,QXE8,QXQ,QXS,QXS2,QXU,QXW,QXW2,QX2,QX22,QX26,QX4,RAC,RD,RD4,REX4,RFR,RFR2,RH,RHA,RHA2,RHQ4,RH2,RH26,RMB4,RMD,RMG2,RNG,RSK,RSS1,RTB2,RX,RXE,RXE2,RXE4,RXU,RX4,SAC,SAD2,SCJ,SD,SDB1,SDB3,SDS,SDS2,SDS3,SD16,SD4,SE,SEE,SG24,SH,SHM,SHQ4,SHRY,SHR4,SJ,SJG,SMB4,SMC7,SMC9,SMW2,SMX4,SM11,SM12,SM14,SNX,SNX1,SSK1,SSK2,SSX2,ST,STA,STM,STP,STQ,SWG4,SWX,SWX2,SWX4,SW2,SX,SXB,SXE,SXE4,SXS4,SXU,SX4,S1CY,TCS2,TH,THU,TX,TXC9,TXU,TX2,TX26,TX4,UH,UX,UXU,VA,VEBM,VEB2,VED6,VEN2,VES,VG24,VSB1,VTE2,VVA,VXG,VXW,VXW1,WDA6,WJP,WKD6,WKT2,WKT4,WKT6,WMB0,WME4	
							2949495 SMJ,SMJ1	
							3943828 VGE4,VMB3,VSD,VSD1,VWA2,VXW2	
							4805338 VSW,VXM,VXU	
							4913229 EMA2,VA2,VED,VED1,VED2,VED3,VED5,VH,VHH4,VHQ4,VMS4,VS,VSX,VSX1,VS1,VS3,VS4,VW12,VX,VXD,VXD1,VXE,VXE4,VX2,VX26,VX4,WME2	
							7402813 LJ,QXM1,SKM,WMT	
			-	1	-	1		

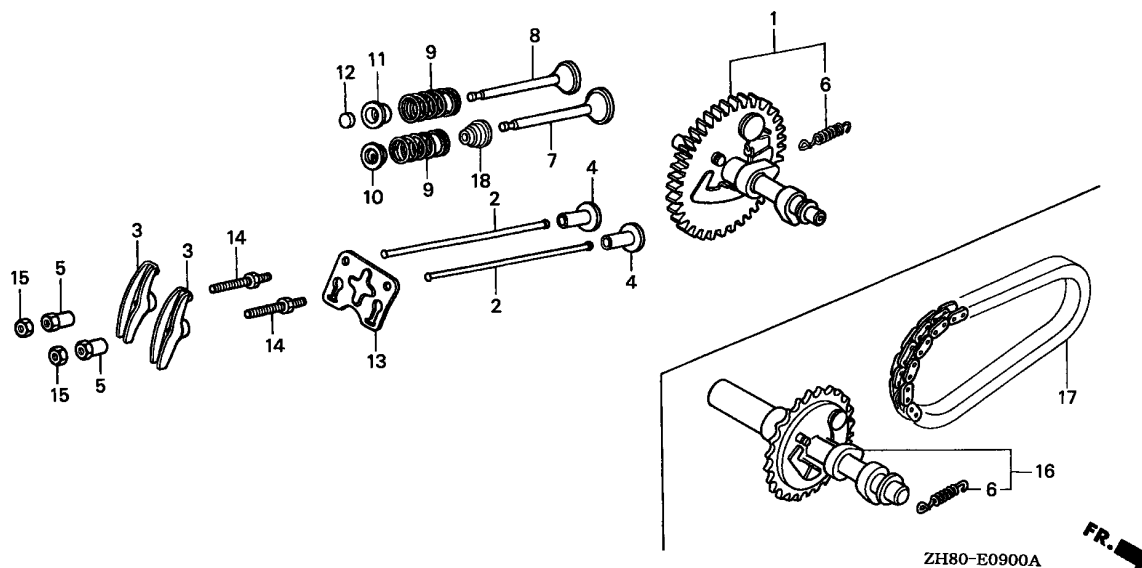

Ref. No.	L.O.N.	(Relative ref. Number) Description	F.R.T.
+ 7		.INCLUDES: Valve clearance adjustment and reface	
	1111L1E	.With intake and exhaust all add	0.1
8	1111L0	VALVE, EXHAUST	0.7
		.INCLUDES: Valve clearance adjustment and reface	
	1111L0E	.With intake and exhaust all add	0.1
9	1111P3	SPRING, VALVE :INTAKE	0.6
		.INCLUDES: Valve clearance adjustment	
	1111P3A	.For two add	0.1
	1111P4	SPRING, VALVE :EXHAUST	0.6
		.INCLUDES: Valve clearance adjustment	
	1111P4A	.For two add	0.1
12	1111J7	ROTATOR, VALVE	0.2
		.INCLUDES: Valve clearance adjustment	
17	2141C3	CHAIN, POWER TAKE OFF DRIVE ..	0.7
18	1111K2	SEAL, INTAKE VALVE STEM	0.6
		.INCLUDES: Valve clearance adjustment	

Ref. No.	Part No.	Description	Reqd. QTY				Serial No.	Parts catalogue code	
			(1)	(2)	(3)	(4)			
(1)	14100-ZL0-000	CAMSHAFT ASSY.	1	-	1	-	-----	VIH1,VMT,VPM4,VPM5,VPR4,VSG,VSX3,VTD,VTD1,VTU1,VTX,VTX1,VXE6 VXU1	
			1	-	-	-	3943829	-----	VGE4,VMB3,VSD,VSD1,VWA2,VXW2
			1	-	-	-	4805339	-----	VSW,VXM,VXU
			1	-	-	-	4913230	-----	EMA2,VA2,VH,VHH4,VHQ4,VMS4,VS,VSX,VSX1,VS1,VS3,VS4,VW12,VX,VXD VXD1,VXE,VXE4,VX2,VX26,VX4,WME2
			1	-	-	-	5048024	-----	VED7
			1	-	-	-	4913230	5048024	VED,VED1,VED2,VED3,VED5
	14100-Z8K-870	1	-	-	-	-----	-----	QX7,SX7
	14100-ZE1-812	1	-	-	-	-----	-----	HXE2,QBC2,RXE2,VEN2,VES
			1	-	-	-	5048025	-----	VED,VED1,VED2,VED3,VED5,VED7
	14100-ZF1-010	1	-	1	-	-----	-----	LTA,PM,QCL,QIH1,QM,QT,QXF,QXF2,QZ,SDN,SJC,SJC1,SJC5,UIH,WIH1
			1	-	-	-	2949496	7440273	SMJ,SMJ1
	14100-ZL0-870	1	-	-	-	-----	-----	VHA7,VMS7,VPM7,VPR7,VSD7,VS17,VXE7
	14100-ZH8-800	1	-	-	-	7402814	-----	LJ,QXM1,SKM,WMT
	14100-ZH8-810	1	-	-	-	7440274	-----	SMJ,SMJ1
	14100-ZH8-C30	1	-	-	-	-----	-----	AR,ARC6,KR
2	14410-ZE1-010	ROD, PUSH	2	2	2	2			
3	14431-ZE1-000	ARM, VALVE ROCKER	2	2	2	2			
4	14441-ZE1-010	LIFTER, VALVE	2	2	2	2			
5	14451-ZE1-013	PIVOT, ROCKER ARM	2	2	2	2			
6	14568-ZE1-000	SPRING, WEIGHT RETURN	1	1	1	1			
7	14711-ZF1-000	VALVE, IN.	1	1	1	1			
8	14721-ZE7-000	VALVE, EX.	1	-	-	-	-----	-----	STM
			-	-	-	1			



E-9

CAMSHAFT

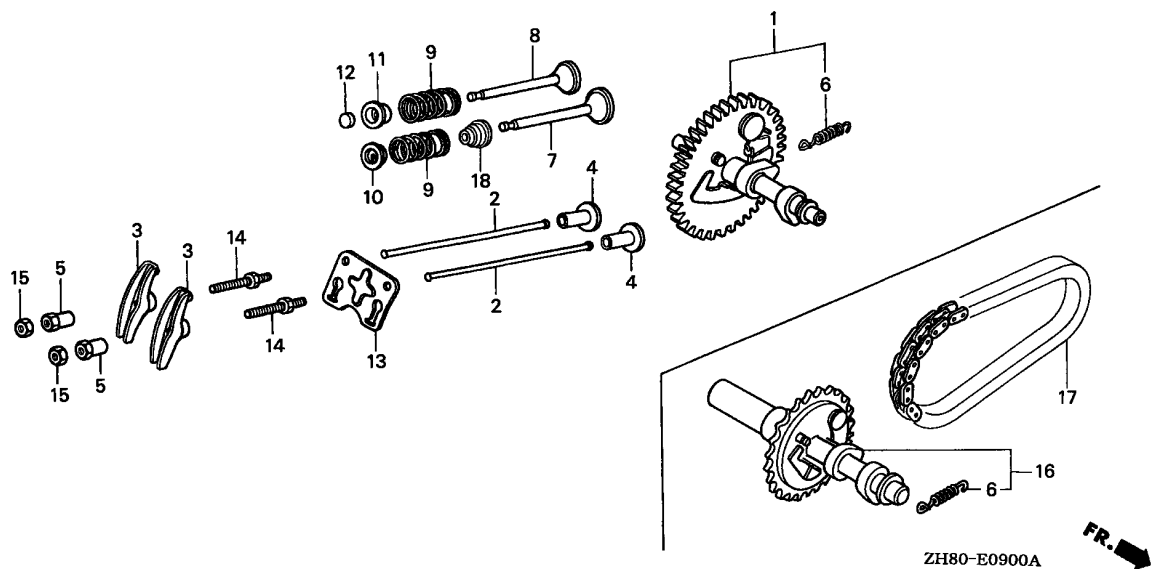

ZH80-E0900A



Ref. No.	Part No.	Description	Reqd. QTY				Serial No.	Parts catalogue code
			(1)	(2)	(3)	(4)		
			GX160K1					
(8)	14721-ZF1-000	VALVE, EX.	1	-	-	-	-----	AR, ARC6, DS, DSP, EMA, EMA2, EN, ET, ETX, HG1, HG12, HH, HHQ4, HH26, HX, HXE, HXE2, HXE8, HXQ, HXU, HX2, HX26, HX4, KR, KTA, LAX, LAX2, LD, LDB1, LDB3, LDM, LD4, LH, LHQ4, LHW, LJ, LJC7, LJD, LJG, LJS, LMT, LSJ, LSJ4, LSS, LSS1, LSS4, LTA, LTK, LW2, LX, LXU, LX2, LX26, LX4, NJ, NJC1, NJG, NSJ, NW, PM, PM2, QA, QAB1, QAX, QAX2, QA2, QA26, QBC2, QBT2, QBT6, QBU2, QCB2, QCL, QD, QE, QFE4, QGR2, QGR9, QH, QHE, QHP1, QHQ4, QH26, QI2, QKA4, QM, QMC6, QMC8, QMD6, QME4, QMH, QMX2, QMZ2, QNT, QNT2, QNT4, QNZ, QP, QPU, QSC2, QSC9, QS2, QT, QWA4, QWM2, QWX2, QWX3, QX, QXB, QXB1, QXC, QXC6, QXC9, QXE, QXE2, QXE4, QXE6, QXE8, QXF, QXF2, QXM1, QXQ, QXS, QXS2, QXU, QXW, QXW2, QX2, QX22, QX26, QX4, QX7, QZ, RAC, RD, RD4, REX4, RFR, RFR2, RH, RHA, RHA2, RHQ4, RH2, RH26, RMB4, RMD, RMG2, RNG, RSK, RSS1, RTB2, RX, RXE, RXE2, RXE4, RXU, RX4, SAC, SAD2, SCJ, SD, SDB1, SDB3, SDN, SDS, SDS2, SDS3, SD16, SD4, SE, SEE, SG24, SH, SHM, SHQ4, SHRY, SHR4, SJ, SJC, SJC1, SJC5, SJG, SKM, SMB4, SMC7, SMC9, SMJ, SMJ1, SMW2, SMX4, SM11, SM12, SM14, SNX, SNX1, SSK1, SSK2, SSS2, ST, STA, STM, STP, STQ, SWG4, SWX, SWX2, SWX4, SW2, SX, SXB, SXE, SXE4, SXS4, SXU, SX4, SX7, S1CY, TXC9, VA, VA2, VEBM, VEB2, VED, VED1, VED2, VED3, VED5, VED6, VED7, VEN2, VES, VGE4, VG24, VH, VHA7, VHH4, VHQ4, VMB3, VMS4, VMS7, VMT, VPM4, VPM5, VPM7, VPR4, VPR7, VS, VSB1, VSD, VSD1, VSD7, VSG, VSW, VSX, VSX1, VSX3, VS1, VS17, VS3, VS4, VTD, VTD1, VTE2, VTU1, VTX, VTX1, VWA, VWA2, VW12, VX, VXD, VXD1, VXE, VXE4, VXE6, VXE7, VVG, VXM, VXU, VXU1, VXW, VXW1, VXW2, VX2, VX26, VX4, WDA6, WJP, WKD6, WKT2, WKT4, WKT6, WMB0, WME2, WME4, WMT
			1	-	-	-	-----	6649704 BL, LHB3, QAB3
	14721-ZH8-810	VALVE, EX. (STELLITE)	1	-	-	-	-----	PH, PHM, PHU, PX, PXU, PX2, TCS2, TH, THU, TX, TXU, TX2, TX26, TX4, UH, UX, UXU
			-	1	-	-		

Ref. No.	Part No.	Description	Reqd. QTY				Serial No.	Parts catalogue code
			(1)	(2)	(3)	(4)		
(8)	14721-ZK8-W80	VALVE, EX.	1	-	-	-	LVL,QVL BL,LHB3,QAB3	
9	14751-ZF1-000	SPRING, VALVE	2	-	-	-	6649705 -----	
							AR,ARC6,BL,DS,DSP,EMA,EMA2,EN,ET,ETX,HG1,HG12,HH,HHQ4,HH26,HX HXE,HXE2,HXE8,HXQ,HXU,HX2,HX26,HX4,KR,KTA,LAX,LAX2,LD,LDB1 LDB3,LDM,LD4,LH,LHB3,LHQ4,LHW,LJ,LJC7,LJD,LJG,LJS,LMT,LSJ,LSJ4 LSS,LSS1,LSS4,LTA,LTK,LVL,LW2,LX,LXU,LX2,LX26,LX4,NJ,NJC1,NJG NSJ,NW,PH,PHM,PHU,PM,PM2,PX,PXU,PX2,QA,QAB1,QAB3,QAX,QAX2,QA2 QA26,QBC2,QBT2,QBT6,QBU2,QCB2,QCL,QD,QE,QFE4,QGR2,QGR9,QH,QHE QHP1,QHQ4,QH26,QI2,QKA4,QM,QMC6,QMC8,QMD6,QME4,QMH,QMX2,QM2 QNT,QNT2,QNT4,QNZ,QP,QPU,QSC2,QSC9,QS2,QT,QVL,QWA4,QWM2,QWX2 QWX3,QX,QXB,QXB1,QXC,QXC6,QXC9,QXE,QXE2,QXE4,QXE6,QXE8,QXF QXF2,QXM1,QXQ,QXS,QXS2,QXU,QXW,QXW2,QX2,QX22,QX26,QX4,QX7,QZ RAC,RD,RD4,REX4,RFR,RFR2,RH,RHA,RHA2,RHQ4,RH2,RH26,RMB4,RMD RMG2,RNG,RSK,RSS1,RTB2,RX,RXE,RXE2,RXE4,RXU,RX4,SAC,SAD2,SCJ SD,SDB1,SDB3,SDN,SDS,SDS2,SDS3,SD16,SD4,SE,SEE,SG24,SH,SHM SHQ4,SHRY,SHR4,SJ,SJC,SJC1,SJC5,SJG,SKM,SMB4,SMC7,SMC9,SMJ SMJ1,SMW2,SMX4,SM11,SM12,SM14,SNX,SNX1,SSK1,SSK2,SSX2,ST,STA STM,STP,STQ,SWG4,SWX,SWX2,SWX4,SW2,SX,SXB,SXE,SXE4,SXS4,SXU SX4,SX7,S1CY,TCS2,TH,THU,TX,TXC9,TXU,TX2,TX26,TX4,UH,UX,UXU,VA VA2,VEBM,VEB2,VED,VED1,VED2,VED3,VED5,VED6,VED7,VEN2,VES,VGE4 VG24,VH,VHA7,VHH4,VHQ4,VMB3,VMS4,VMS7,VMT,VPM4,VPM5,VPM7,VPR4 VPR7,VS,VS1,VSD,VSD1,VSD7,VSG,VSW,VSX,VSX1,VSX3,VS1,VS17,VS3 VS4,VTD,VTD1,VTE2,VTU1,VTX,VTX1,VWA,VWA2,VW12,VX,VXD,VXD1,VXE4 VXE6,VXE7,VXG,VXM,VXU,VXU1,VXW,VXW1,VXW2,VX2,VX26,VX4 WDA6,WJP,WKD6,WKT2,WKT4,WKT6,WMB0,WME2,WME4	
	14751-ZH8-940	2	-	-	-	WMT	
10	14771-ZE1-000	RETAINER, IN. VALVE SPRING ..	1	1	1	1		
11	14773-ZE1-000	RETAINER, EX. VALVE SPRING ..	1	1	1	-		
	14771-ZE1-000	RETAINER, IN. VALVE SPRING ..	-	-	-	1		
12	14781-ZE1-000	ROTATOR, VALVE	1	1	1	-		
13	14791-ZE1-010	PLATE, PUSH ROD GUIDE	1	1	1	1		
14	90012-ZE0-010	BOLT, PIVOT, 8MM	2	2	2	2		
15	90206-ZE1-000	NUT, PIVOT ADJUSTING	2	2	2	2		
16	14100-ZH8-690	CAMSHAFT ASSY.	1	-	-	-	NJ,NJC1,NJG,NSJ,NW	
17	14411-ZH7-V91	CHAIN, P.T.O. DRIVE (DID270FH DHA-3)	1	-	-	-	NJ,NJC1,NJG,NSJ,NW	
18	12209-ZH8-003	SEAL, VALVE STEM	1	1	-	-	7664037 -----	
							AR,ARC6,BL,EMA2,HG12,HH,HHQ4,HH26,HX,HXE,HXE8,HXU,HX2,HX26,HX4 KR,KTA,LD,LH,LHB3,LHQ4,LJ,LJC7,LJG,LJS,LSJ4,LW2,LX,LXU,LX2 LX26,LX4,L1,NJ,NJC1,NJG,NSJ,PHM,PXU,QAB1,QAB3,QAX2,QA2,QA26 QBT6,QCB2,QCL,QD,QE,QFE4,QGR2,QGR9,QH,QHE,QHP1,QHQ4,QH26,QI2 QKA4,QM,QMC6,QMC8,QMD6,QME4,QMH,QMX2,QM2,QNT,QNT4,QNZ,QP,QPU QSC2,QSC9,QT,QWA4,QWX2,QX,QXC,QXC6,QXC9,QXE,QXE2,QXE4,QXE6 QXE8,QXF2,QXM1,QXS2,QXU,QXW,QXW2,QX2,QX22,QX26,QX4,RD,RD4,RFR2 RH,RHA2,RHQ4,RH2,RH26,RMB4,RMD,RMG2,RSK,RSS1,RTB2,RX,RXE,RXE4 RXU,RX4,SCJ,SD,SDB3,SDS,SD16,SD4,SE,SG24,SH,SHM,SHQ4,SHRY,SHR4 SJ,SJC1,SJC5,SJG,SKM,SMC7,SMC9,SMJ,SMJ1,SMW2,SMX4,SM11,SM12 SM14,SNX,SNX1,SSK1,SSX2,ST,STM,STQ,SWG4,SWX2,SWX4,SX,SXE,SXE4 SXS4,SXU,SX4,S1CY,TCS2,TH,THU,TX,TXC9,TXU,TX2,TX26,TX4,UH,UX,UXU,VA VA2,VEBM,VED,VED1,VED2,VED3,VED5,VED6,VGE4,VG24,VHH4,VMB3,VMS4,VMT VPM4,VPR4,VS1,VSD,VSD1,VSD7,VSG,VSW,VSX,VSX1,VSX3,VS3,VS4,VTD,VTU1,VTX1 VWA2,VW12,VX,VXD,VXE4,VXM,VXU,VXU1,VXW2,VX2,VX4,WDA6,WJP,WKD6 WKT2,WKT4,WMB0,WME2,WME4,WMT HXE2,LVL,QBC2,QIH1,QS2,QVL,QX7,RXE2,SX7,VEN2,VES,VHA7,VIH1 VMS7,VPM5,VPM7,VPR7,VSD7,VSG,VS17,VXE7,WI1,WKT6 SXP1,VXP	



E-11

RECOIL STARTER(1)

J 3

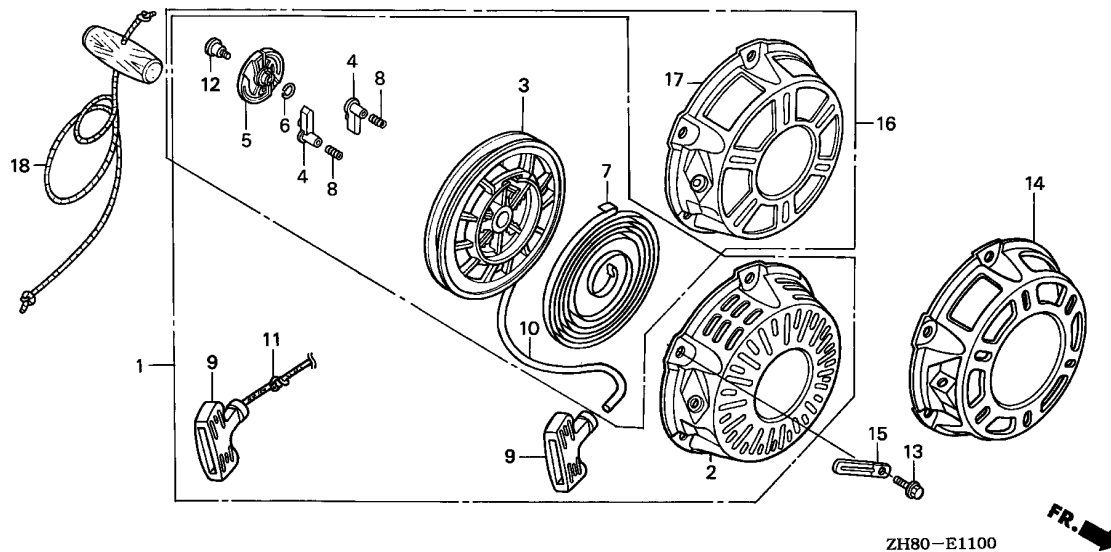

Ref. No.	L.O.N.	(Relative ref. Number) Description	F.R.T.
1	1121B9	STARTER, RECOIL	0.1
3	1121B1	REEL, RECOIL STARTER	0.3
4	1121B0	RATCHET, STARTER AND/OR SPRING, RATCHET	0.2
5	1121A4	GUIDE, RATCHET	0.2
7	1121B7	SPRING, RECOIL STARTER RETURN	0.3
10	1121B3	ROPE, RECOIL STARTER	0.3
18	1121B3	ROPE, RECOIL STARTER	0.3

2

Ref. No.	Part No.	Description	Reqd. QTY				Serial No.	Parts catalogue code
			(1)	(2)	(3)	(4)		
1	28400-ZH8-013ZA	STARTER ASSY., RECOIL *R8*.....BRIGHT RED	1	(1)	-	-	8367072	HH26, HXE2, HXE8, HXU, HX26, LXU, LX26, L1, PXU, QA26, QBC2, QBT6, QH26, QWA4, QXC6, QXE6, QXE8, QXM1, QXU, QX26, QX7, RH26, RXU, SD16, SXU, SX7, TXU, TX26, UXU, VMS7, VPM7, VPR7, VSD7, VS17, VXE4, VXE7, VXU1, WKT6
			1	-	-	-	2828660	HG1
			1	-	-	-	5551817	SWG4
			1	-	-	-	5641954	STM
			1	-	-	-	6219318	QT
			-	(1)	-	-		H1, Q1, R1, S1, T1, U1, V1, W1
			-	-	-	1	2000271	SXP1
	28400-ZH8-013ZB	*NH1*.....BLACK	1	-	-	-		EMA, EMA2, HXQ, HX2, LX2, PX2, QA2, QBU2, QCB2, QMC8, QMX2, QMZ2, QNT2, QWM2, QXC9, QXE2, QXF2, QXQ, QXS2, QX2, QX4, RD, RH2, SG24, SMB4, SMX4, SM12, SM14, SSK1, SSK2, SXS2, TX2, TX4, VED, VED1, VED2, VED6, VED7, VEN2, VG24, VWA2, VXD, VXD1, VXW2, VX2
	28400-ZH8-013ZC	*T39*.....GEKO BLUE	1	-	-	-		VMB3, VX4
	28400-ZH8-013ZD	*T41*.....BARTELL BLUE METALLIC	1	-	-	-		QBT2, QBT6, QX2, QX4
	28400-ZH8-013ZG	*NH105*...MAT BLACK (#15-#20)	1	-	-	-		QWX2, QWX3, SWX2, SWX4, VSD7, VWA2, VW12, VXW1, VX4
	28400-ZH8-013ZP	*T68*.....TSURUMI BLUE	1	-	-	-		VED2
	28400-ZH8-013ZQ	*Y131*.....LIGHTNING YELLOW	1	-	-	-		VED2, VSX1
	28400-ZH8-013ZT	*T77*.....SEC WINE RED	1	-	-	-		VSX
	28400-ZH8-013ZW	*T80*.....BAKELITE ORANGE	1	-	-	-		VTD, VTD1, VTX, VTX1
	28400-ZH8-821ZA	STARTER ASSY., RECOIL (LONG ROPE) *R8*.....BRIGHT RED	-	(1)	-	-	2438252	
	28400-ZH8-822ZA	*R8*.....BRIGHT RED	1	-	-	-		QSC9
			-	(1)	-	-	2438253	
	28400-ZH8-822ZC	*NH1*.....BLACK	1	-	-	-		QSC9

Ref. No.	Part No.	Description	Reqd. QTY				Serial No.	Parts catalogue code	
			GX160K1	(1)	(2)	(3)			(4)
(1)	28400-ZH8-R10ZA	STARTER ASSY., RECOIL (TURFCO) *R8*.....BRIGHT RED	1	-	-	-	-----	HG12,SNX,SNX1	
			1	-	-	-	2828661	-----	HG1
	28400-ZH8-013YA	STARTER ASSY., RECOIL *R280*.....POWER RED	1	(1)	-	-	8367073	-----	HH26,HXE2,HXE8,HXU,HX26,LXU,LX26,L1,PXU,QA26,QBC2,QBT6,QH26 QWA4,QXC6,QXE6,QXE8,QXM1,QXU,QX26,QX7,RH26,RXU,SD16,SXU, SX7 TXU, TX26,UXU,VMS7,VPM7,VPR7,VSD7,VS17,VXE4,VXE7,VXU1,WKT6 AR,ARC6,BL,HH,HHQ4,HX,HX2,HX4,KR,KTA,LD,LH,LHB3,LHQ4,LJ,LJC7 LJG,LSJ4,LW2,LX,LX2,LX4,NJ,NJG,NSJ,PHM,PX,QAB3,QAX2,QA2,QCB2 QCL,QD,QE,QFE4,QGR2,QGR9,QH,QHE,QHP1,QHQ4,QI2,QKA4,QMC6,QMC8 QMD6,QME4,QMH,QMX2,QMZ2,QNT,QNT4,QNZ,QP,QPU,QSC2,QS2,QX,QXC QXC9,QXE,QXE2,QXE4,QXF2,QXS2,QXW,QX2,QX22,QX4,RD,RD4,RH,RHA2 RHQ4,RH2,RMB4,RMD,RMG2,RSK,RSS1,RTB2,RX,RXE,RXE2,RXE4,RX4,SCJ SD,SDS,SD4,SE,SG24,SH,SHM,SHQ4,SHRY,SJ,SJC1,SJC5,SJG,SMC7,SMC9 SMJ,SMJ1,SMW2,SMX4,SM11,SM12,SM14,ST,STQ, SX,SXE,SXE4,SXS4, SX4 S1CY,TCS2,TX,TXC9,TX2,TX4,VA2,VEBM,VED,VED1,VED2,VED3,VES,VGE4 VG24,VHA7,VHH4,VMS4,VMT,VPM4,VPM5,VPR4,VSD,VSD1,VSX,VSX1,VSX3 VTU1,VX,VXM,VXU,VXW2,VX2,VX4,WDA6,WJP,WKD6,WKT2,WKT4,WMB0,WME2 WME4,WMT
			-	-	-	1	2000272	-----	SXP1
2	28410-ZH8-003ZA	CASE COMP., RECOIL STARTER *R8*.....BRIGHT RED	1	(1)	-	1	-----	-----	AR,ARC6,BL,DS,DSP,EN,ET,ETX,HG1,HG12,HH,HHQ4,HX,HXE,HXQ,HX2 HX4,H1,KR,KTA,LAX,LAX2,LD,LDB1,LDB3,LDM,LD4,LH,LHB3,LHQ4,LHW LJ,LJC7,LJD,LJG,LSJ,LSJ4,LSS,LSS1,LSS4, LTA,LTK,LW2,LX,LX2,LX4 NJ,NJG,NSJ,NW,PH,PHM,PHU,PM,PM2,PX,PX2,QA,QAB1,QAB3,QAX,QAX2 QA2,QBU2,QCB2,QCL,QD,QE,QFE4,QGR2,QGR9,QH,QHE,QHP1,QHQ4,QI2 QKA4,QM,QMC6,QMC8,QMD6,QME4,QMH,QMX2,QMZ2,QNT,QNT2,QNT4,QNZ,QP QPU,QSC2,QX,QXB,QXB1,QXC,QXC9,QXE,QXE2,QXF,QXF2,QXQ,QXS,QXS2 QXW,QXW2,QX2,QX22,QX4,QZ,Q1,RAC,RD,RD4,REX4,RFR,RFR2,RH,RHA RHA2,RHQ4,RH2,RMB4,RMD,RMG2,RNG,RSK,RSS1,RTB2,RX,RXE,RXE2,RX4 R1,SAC,SAD2,SCJ,SD,SDB1,SDB3,SDN,SDS,SDS2,SDS3,SD4,SE,SEE,SH SHM,SHQ4,SHRY,SHR4,SJ,SJC,SJC1,SJC5,SJG,SMB4,SMC7,SMC9,SMJ SMJ1,SMW2,SMX4,SM11,SM12,SM14,SNX,SNX1,ST,STA,STP,STQ,SWX,SW2 SX, SXB,SXE,SXE4,SXS4, SX4,S1,S1CY,TCS2,TH,THU,TX,TXC9,TX2,TX4 T1,UH,UX,U1,VA,VA2,VEBM,VEB2,VED,VED1,VED2,VED3,VED5,VGE4,VH VHH4,VHQ4,VMB3,VMS4,VMT,VPM4,VPR4,VS,VSD,VSDP,VSD1,VSX,VSX1 VSX3,VS1, VTD,VTE2,VTU1,VWA,VX,VXE,VXE6,VXG,VXM,VXP,VXU,VXW VXW2,VX2,VX26,VX4,V1,WDA6,WJP,WKD6,WKT2,WKT4,WMB0,WME2,WME4 WMT,W1
			1	(1)	-	-	8367072	-----	HH26,HXE2,HXE8,HXU,HX26,LXU,LX26,L1,PXU,QA26,QBC2,QBT6,QH26 QSC9,QWA4,QXC6,QXE4,QXE8,QXE8,QXM1,QXU,QX26,QX7,RH26,RXE4,RXU SD16,SXU, SX7, TXU, TX26,UXU,VMS7,VPM7,VPR7,VSD7,VS17,VXE4,VXE7 VXU1,WKT6
			1	-	-	-	5551817	-----	SWG4
			1	-	-	-	5641954	-----	STM
			1	-	-	-	6219318	-----	QT
			-	-	1	-	-	-----	-
			-	-	-	1	2000271	-----	SXP1
	28410-ZH8-003ZB	*NH1*.....BLACK	1	-	-	-	-----	-----	EMA,EMA2,HXQ,HX2,LX2,PX2,QA2,QBU2,QCB2,QMC8,QMX2,QMZ2,QNT2 QSC9,QWM2,QXC9,QXE2,QXF2,QXQ,QXS2,QX2,QX4,RD,RH2,SG24,SMB4 SMX4,SM12,SM14,SSK1,SSK2,SSX2,TX2,TX4,VED,VED1,VED2,VED6,VED7 VEN2,VG24,VWA2,VXD,VXD1,VXW2,VX2
	28410-ZH8-003ZC	*T39*.....GEKO BLUE	1	-	-	-	-----	-----	VMB3,VX4
	28410-ZH8-003ZD	*T41*...BARTELL BLUE METALLIC	1	-	-	-	-----	-----	QBT2,QBT6,QX2,QX4
	28410-ZH8-003ZG	*NH105*...MAT BLACK (#15-#20)	1	-	-	-	-----	-----	QWX2,QWX3,SWX2,SWX4,VSD7,VWA2,VW12,VXW1,VX4
	28410-ZH8-003ZP	*T68*.....TSURUMI BLUE	1	-	-	-	-----	-----	VED2
	28410-ZH8-003ZQ	*Y131*.....LIGHTNING YELLOW	1	-	-	-	-----	-----	VED2,VSX1



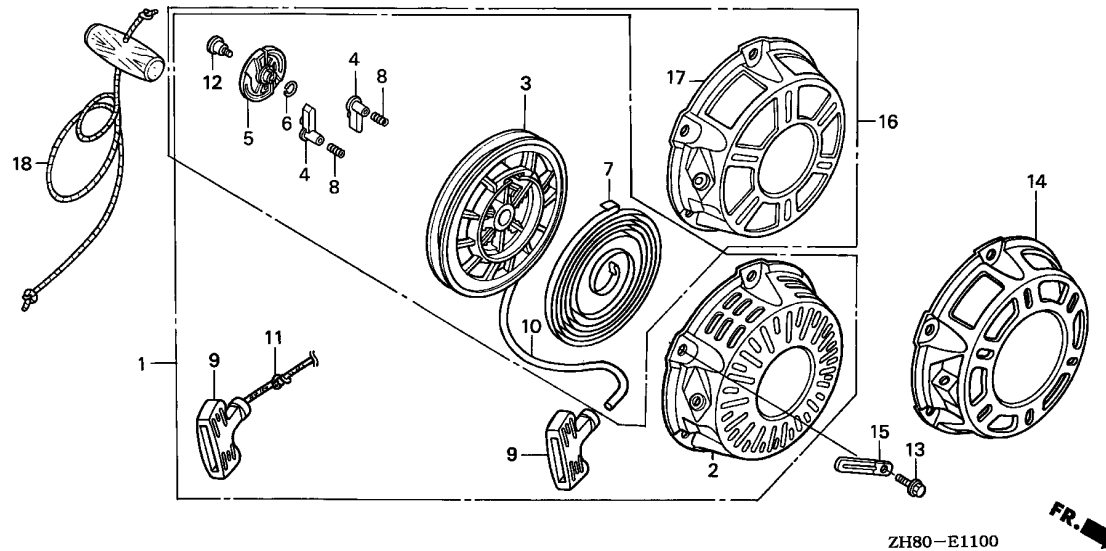

2

Ref. No.	Part No.	Description	Reqd. QTY				Serial No.	Parts catalogue code
			(1)	(2)	(3)	(4)		
(2)	28410-ZH8-003ZT	CASE COMP., RECOIL STARTER						
		T77.....SEC WINE RED	1	-	-	-	-----	VSX
	28410-ZH8-003ZW	*T80*.....BAKELITE ORANGE	1	-	-	-	-----	VTD,VTD1,VTX,VTX1
	28410-ZH8-003YA	*R280*.....POWER RED	1	(1)	-	-	8367073	HH26,HXE2,HXE8,HXU,HX26,LXU,LX26,L1,PXU,QA26,QBC2,QBT6,QH26 QSC9,QWA4,QXC6,QXE4,QXE6,QXE8,QXM1,QXU,QX26,QX7,RH26,RXE4,RXU SD16,SXU,SX7,TXU,TX26,UXU,VMS7,VPM7,VPR7,VSD7,VS17,VXE4,VXE7 VXU1,WKT6
			1	-	-	-	-----	QS2,VES,VHA7,VPM5
			-	-	-	1	2000272	SXP1

Ref. No.	Part No.	Description	Reqd. QTY				Serial No.	Parts catalogue code					
			(1)	(2)	(3)	(4)							
3	28420-ZH8-013	REEL, RECOIL STARTER (NATURAL)	1	-	-	-	-----	AR,ARC6,BL,DS,DSP,EMA,EMA2,EN,ET,ETX,HG1,HG12,HH,HHQ4,HH26,HX HXE,HXE2,HXE8,HXQ,HXU,HX2,HX26,HX4,KR,KTA,LAX,LAX2,LD,LDB1 LDB3,LDM,LD4,LH,LHB3,LHQ4,LHW,LJ,LJC7,LJD,LJG,LSJ,LSJ4,LSS LSS1,LSS4,LTA,LTK,LW2,LX,LXU,LX2,LX26,LX4,NJ,NJC1,NJG,NSJ,NW PH,PHM,PHU,PM,PM2,PX,PXU,PX2,QA,QAB1,QAB3,QAX,QAX2,QA2,QA26 QBC2,QBT2,QBT6,QBU2,QCB2,QCL,QD,QE,QFE4,QGR2,QGR9,QH,QHE,QHP1 QHQ4,QH26,QI2,QKA4,QM,QMC6,QMC8,QMD6,QME4,QMH,QMX2,QM22,QNT QNT2,QNT4,QNZ,QP,QPU,QSC2,QSC9,QS2,QWA4,QWM2,QWX2,QWX3,QX,QXB QXB1,QXC,QXC6,QXC9,QXE,QXE2,QXE4,QXE6,QXE8,QXF,QXF2,QXM1,QXQ QXS,QXS2,QXU,QXW,QXW2,QX2,QX22,QX26,QX4,QX7,QZ,RAC,RD,RD4,REX4 RFR,RFR2,RH,RHA,RHA2,RHQ4,RH2,RH26,RMB4,RMD,RMG2,RNG,RSK,RSS1 RTB2,RX,RXE,RXE2,RXE4,RXU,RX4,SAC,SAD2,SCJ,SD,SDB1,SDB3,SDN SDS,SDS2,SDS3,SD16,SD4,SE,SEE,SG24,SH,SHM,SHQ4,SHRY,SHR4,SJ SJC,SJC1,SJC5,SJG,SMB4,SMC7,SMC9,SMJ,SMJ1,SMW2,SMX4,SM11,SM12 SM14,SNX,SNX1,SSK1,SSK2,SSX2,ST,STA,STP,STQ,SWX,SWX2,SWX4,SW2 SX,SXB,SXE,SXE4,SXS4,SXU,SX4,SX7,S1CY,TCS2,TH,THU,TX,TXC9,TXU TX2,TX26,TX4,UH,UX,UXU,VA,VA2,VEBM,VEB2,VED,VED1,VED2,VED3 VED5,VED6,VED7,VEN2,VES,VGE4,VG24,VH,VHA7,VHH4,VHQ4,VMB3,VMS4 VMS7,VMT,VPM4,VPM5,VPM7,VPR4,VPR7,VS,VSD,VSD1,VSD7,VSX,VSX1 VSX3,VS1,VS17,VD,VD1,VTE2,VTU1,VTX,VTX1,VVA,VWA2,VW12,VX,VXD VXD1,VXE,VXE4,VXE6,VXE7,VXG,VXM,VXU,VXU1,VXW,VXW1,VXW2,VX2 VX26,VX4,WDA6,WJP,WKD6,WKT2,WKT4,WKT6,WMB0,WME2,WME4,WMT					
			1	-	-	-	-----	5551817 SWG4					
			1	-	-	-	-----	5641954 STM					
			1	-	-	-	-----	6219318 QT					
			-	(1)	1	1							
4	28422-ZH8-013	RATCHET, STARTER	2	-	-	-	-----	AR,ARC6,BL,DS,DSP,EMA,EMA2,EN,ET,ETX,HG1,HG12,HH,HHQ4,HH26,HX HXE,HXE2,HXE8,HXQ,HXU,HX2,HX26,HX4,KR,KTA,LAX,LAX2,LD,LDB1 LDB3,LDM,LD4,LH,LHB3,LHQ4,LHW,LJ,LJC7,LJD,LJG,LSJ,LSJ4,LSS LSS1,LSS4,LTA,LTK,LW2,LX,LXU,LX2,LX26,LX4,NJ,NJC1,NJG,NSJ,NW PH,PHM,PHU,PM,PM2,PX,PXU,PX2,QA,QAB1,QAB3,QAX,QAX2,QA2,QA26 QBC2,QBT2,QBT6,QBU2,QCB2,QCL,QD,QE,QFE4,QGR2,QGR9,QH,QHE,QHP1 QHQ4,QH26,QI2,QKA4,QM,QMC6,QMC8,QMD6,QME4,QMH,QMX2,QM22,QNT QNT2,QNT4,QNZ,QP,QPU,QSC2,QSC9,QS2,QWA4,QWM2,QWX2,QWX3,QX,QXB QXB1,QXC,QXC6,QXC9,QXE,QXE2,QXE4,QXE6,QXE8,QXF,QXF2,QXM1,QXQ QXS,QXS2,QXU,QXW,QXW2,QX2,QX22,QX26,QX4,QX7,QZ,RAC,RD,RD4,REX4 RFR,RFR2,RH,RHA,RHA2,RHQ4,RH2,RH26,RMB4,RMD,RMG2,RNG,RSK,RSS1 RTB2,RX,RXE,RXE2,RXE4,RXU,RX4,SAC,SAD2,SCJ,SD,SDB1,SDB3,SDN SDS,SDS2,SDS3,SD16,SD4,SE,SEE,SG24,SH,SHM,SHQ4,SHRY,SHR4,SJ SJC,SJC1,SJC5,SJG,SMB4,SMC7,SMC9,SMJ,SMJ1,SMW2,SMX4,SM11,SM12 SM14,SNX,SNX1,SSK1,SSK2,SSX2,ST,STA,STP,STQ,SWX,SWX2,SWX4,SW2 SX,SXB,SXE,SXE4,SXS4,SXU,SX4,SX7,S1CY,TCS2,TH,THU,TX,TXC9,TXU TX2,TX26,TX4,UH,UX,UXU,VA,VA2,VEBM,VEB2,VED,VED1,VED2,VED3 VED5,VED6,VED7,VEN2,VES,VGE4,VG24,VH,VHA7,VHH4,VHQ4,VMB3,VMS4 VMS7,VMT,VPM4,VPM5,VPM7,VPR4,VPR7,VS,VSD,VSD1,VSD7,VSX,VSX1 VSX3,VS1,VS17,VD,VD1,VTE2,VTU1,VTX,VTX1,VVA,VWA2,VW12,VX,VXD VXD1,VXE,VXE4,VXE6,VXE7,VXG,VXM,VXU,VXU1,VXW,VXW1,VXW2,VX2 VX26,VX4,WDA6,WJP,WKD6,WKT2,WKT4,WKT6,WMB0,WME2,WME4,WMT					
			2	-	-	-	-----	5551817 SWG4					
			2	-	-	-	-----	5641954 STM					
			2	-	-	-	-----	6219318 QT					
			-	(2)	2	2							



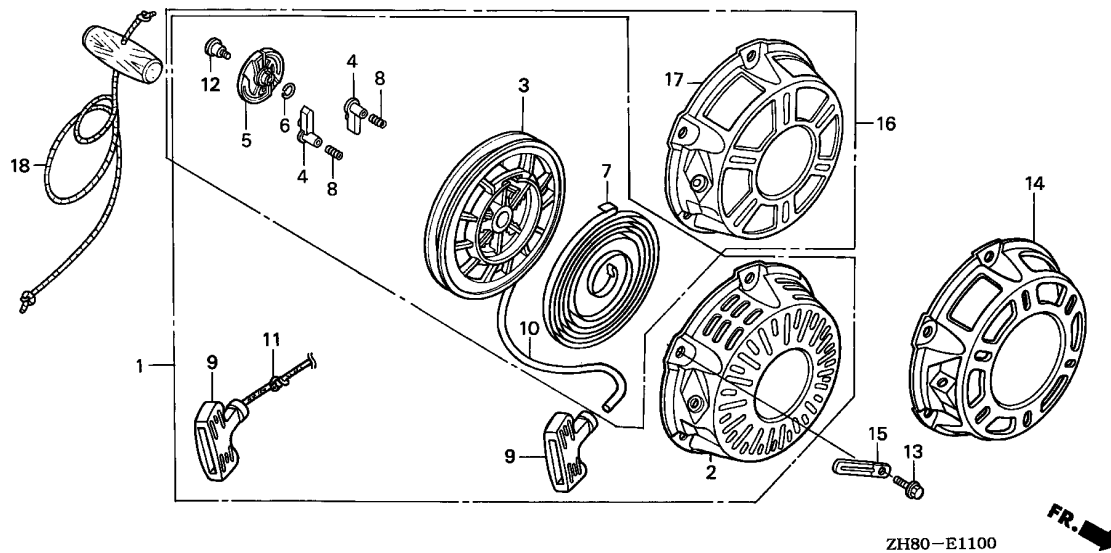

ZH80-E1100



Ref. No.	Part No.	Description	Reqd. QTY				Serial No.	Parts catalogue code				
			(1)	(2)	(3)	(4)						
			GX160K1									
5	28433-ZH8-003	GUIDE, RATCHET	1	-	-	-	AR,ARC6,BL,DS,DSP,EMA,EMA2,EN,ET,ETX,HG1,HG12,HH,HHQ4,HH26,HX HXE,HXE2,HXE8,HXQ,HXU,HX2,HX26,HX4,KR,KTA,LAX,LAX2,LD,LDB1 LDB3,LDM,LD4,LH,LHB3,LHQ4,LHW,LJ,LJC7,LJD,LJG,LSJ,LSJ4,LSS LSS1,LSS4,LTA,LTK,LW2,LX,LXU,LX2,LX26,LX4,NJ,NJC1,NJG,NSJ,NW PH,PHM,PHU,PM,PM2,PX,PXU,PX2,QA,QAB1,QAB3,QAX,QAX2,QA2,QA26 QBC2,QBT2,QBT6,QBU2,QCB2,QCL,QD,QE,QFE4,QGR2,QGR9,QH,QHE,QHP1 QH4,QH26,QI2,QKA4,QM,QMC6,QMC8,QMD6,QME4,QMH,QMX2,QMZ2,QNT QNT2,QNT4,QNZ,QP,QPU,QSC2,QSC9,QS2,QWA4,QWM2,QWX2,QWX3,QX,QXB QXB1,QXC,QXC6,QXC9,QXE,QXE2,QXE4,QXE6,QXE8,QXF,QXF2,QXM1,QXQ QXS,QXS2,QXU,QXW,QXW2,QX2,QX22,QX26,QX4,QX7,QZ,RAC,RD,RD4,REX4 RFR,RFR2,RH,RHA,RHA2,RHQ4,RH2,RH26,RMB4,RMD,RMG2,RNG,RSK,RSS1 RTB2,RX,RXE,RXE2,RXE4,RXU,RX4,SAC,SAD2,SCJ,SD,SDB1,SDB3,SDN SDS,SDS2,SDS3,SD16,SD4,SE,SEE,SG24,SH,SHM,SHQ4,SHRY,SHR4,SJ SJC,SJC1,SJC5,SJG,SMB4,SMC7,SMC9,SMJ,SMJ1,SMW2,SMX4,SM11,SM12 SM14,SNX,SNX1,SSK1,SSK2,SSX2,ST,STA,STP,STQ,SWX,SWX2,SWX4,SW2 SX,SXB,SXE,SXE4,SXS4,SXU,SX4,SX7,S1CY,TCS2,TH,THU,TX,TXC9,TXU TX2,TX26,TX4,UH,UX,UXU,VA,VA2,VEBM,VEB2,VED,VED1,VED2,VED3 VED5,VED6,VED7,VEN2,VES,VGE4,VG24,VH,VHA7,VHH4,VHQ4,VMB3,VMS4 VMS7,VMT,VPM4,VPM5,VPM7,VPR4,VPR7,VS,VSD,VSD1,VSD7,VSX,VSX1 VSX3,VS1,VS17,VTD,VTD1,VTE2,VTU1,VTX,VTX1,VVA,VVA2,VW12,VX,VXD VXD1,VXE,VXE4,VXE6,VXE7,VXG,VXM,VXU,VXU1,VXW,VXW1,VXW2,VX2 VX26,VX4,WDA6,WJP,WKD6,WKT2,WKT4,WKT6,WMB0,WME2,WME4,WMT					
			1	-	-	-	5551817 SWG4					
			1	-	-	-	5641954 STM					
			1	-	-	-	6219318 QT					
			-	(1)	1	1						

Ref. No.	Part No.	Description	Reqd. QTY				Serial No.	Parts catalogue code
			(1)	(2)	(3)	(4)		
6	28441-ZH8-003	SPRING, FRICTION	1	-	-	-	-----	AR,ARC6,BL,DS,DSP,EMA,EMA2,EN,ET,ETX,HG1,HG12,HH,HHQ4,HH26,HX HXE,HXE2,HXE8,HXQ,HXU,HX2,HX26,HX4,KR,KTA,LAX,LAX2,LD,LDB1 LDB3,LDM,LD4,LH,LHB3,LHQ4,LHW,LJ,LJC7,LJD,LJG,LSJ,LSJ4,LSS LSS1,LSS4,LTA,LTK,LW2,LX,LXU,LX2,LX26,LX4,NJ,NJC1,NJG,NSJ,NW PH,PHM,PHU,PM,PM2,PX,PXU,PX2,QA,QAB1,QAB3,QAX,QAX2,QA2,QA26 QBC2,QBT2,QBT6,QBU2,QCB2,QCL,QD,QE,QFE4,QGR2,QGR9,QH,QHE,QHP1 QHQ4,QH26,QI2,QKA4,QM,QMC6,QMC8,QMD6,QME4,QMH,QMX2,QM22,QNT QNT2,QNT4,QNZ,QP,QPU,QSC2,QSC9,QS2,QWA4,QWM2,QWX2,QWX3,QX,QXB QXB1,QXC,QXC6,QXC9,QXE,QXE2,QXE4,QXE6,QXE8,QXF,QXF2,QXM1,QXQ QXS,QXS2,QXU,QXW,QXW2,QX2,QX22,QX26,QX4,QX7,QZ,RAC,RD,RD4,REX4 RFR,RFR2,RH,RHA,RHA2,RHQ4,RH2,RH26,RMB4,RMD,RMG2,RNG,RSK,RSS1 RTB2,RX,RXE,RXE2,RXE4,RXU,RX4,SAC,SAD2,SCJ,SD,SDB1,SDB3,SDN SDS,SDS2,SDS3,SD16,SD4,SE,SEE,SG24,SH,SHM,SHQ4,SHRY,SHR4,SJ SJC,SJC1,SJC5,SJG,SMB4,SMC7,SMC9,SMJ,SMJ1,SMW2,SMX4,SM11,SM12 SM14,SNX,SNX1,SSK1,SSK2,SSX2,ST,STA,STP,STQ,SWX,SWX2,SWX4,SW2 SX,SXB,SXE,SXE4,SXS4,SXU,SX4,SX7,S1CY,TCS2,TH,THU,TX,TXC9,TXU TX2,TX26,TX4,UH,UX,UXU,VA,VA2,VEBM,VEB2,VED,VED1,VED2,VED3 VED5,VED6,VED7,VEN2,VES,VGE4,VG24,VH,VHA7,VHH4,VHQ4,VMB3,VMS4 VMS7,VMT,VPM4,VPM5,VPM7,VPR4,VPR7,VS,VSD,VSD1,VSD7,VSX,VSX1 VSX3,VS1,VS17,VD,VD1,VTE2,VTU1,VTX,VTX1,VVA,VWA2,VW12,VX,VXD VXD1,VXE,VXE4,VXE6,VXE7,VXG,VXM,VXU,VXU1,VXW,VXW1,VXW2,VX2 VX26,VX4,WDA6,WJP,WKD6,WKT2,WKT4,WKT6,WMB0,WME2,WME4,WMT
			1	-	-	-	-----	5551817 SWG4
			1	-	-	-	-----	5641954 STM
			1	-	-	-	-----	6219318 QT
			-	(1)	1	1		
7	28442-ZH8-003	SPRING, RECOIL STARTER	1	-	-	-	-----	AR,ARC6,BL,DS,DSP,EMA,EMA2,EN,ET,ETX,HG1,HG12,HH,HHQ4,HH26,HX HXE,HXE2,HXE8,HXQ,HXU,HX2,HX26,HX4,KR,KTA,LAX,LAX2,LD,LDB1 LDB3,LDM,LD4,LH,LHB3,LHQ4,LHW,LJ,LJC7,LJD,LJG,LSJ,LSJ4,LSS LSS1,LSS4,LTA,LTK,LW2,LX,LXU,LX2,LX26,LX4,NJ,NJC1,NJG,NSJ,NW PH,PHM,PHU,PM,PM2,PX,PXU,PX2,QA,QAB1,QAB3,QAX,QAX2,QA2,QA26 QBC2,QBT2,QBT6,QBU2,QCB2,QCL,QD,QE,QFE4,QGR2,QGR9,QH,QHE,QHP1 QHQ4,QH26,QI2,QKA4,QM,QMC6,QMC8,QMD6,QME4,QMH,QMX2,QM22,QNT QNT2,QNT4,QNZ,QP,QPU,QSC2,QSC9,QS2,QWA4,QWM2,QWX2,QWX3,QX,QXB QXB1,QXC,QXC6,QXC9,QXE,QXE2,QXE4,QXE6,QXE8,QXF,QXF2,QXM1,QXQ QXS,QXS2,QXU,QXW,QXW2,QX2,QX22,QX26,QX4,QX7,QZ,RAC,RD,RD4,REX4 RFR,RFR2,RH,RHA,RHA2,RHQ4,RH2,RH26,RMB4,RMD,RMG2,RNG,RSK,RSS1 RTB2,RX,RXE,RXE2,RXE4,RXU,RX4,SAC,SAD2,SCJ,SD,SDB1,SDB3,SDN SDS,SDS2,SDS3,SD16,SD4,SE,SEE,SG24,SH,SHM,SHQ4,SHRY,SHR4,SJ SJC,SJC1,SJC5,SJG,SMB4,SMC7,SMC9,SMJ,SMJ1,SMW2,SMX4,SM11,SM12 SM14,SNX,SNX1,SSK1,SSK2,SSX2,ST,STA,STP,STQ,SWX,SWX2,SWX4,SW2 SX,SXB,SXE,SXE4,SXS4,SXU,SX4,SX7,S1CY,TCS2,TH,THU,TX,TXC9,TXU TX2,TX26,TX4,UH,UX,UXU,VA,VA2,VEBM,VEB2,VED,VED1,VED2,VED3 VED5,VED6,VED7,VEN2,VES,VGE4,VG24,VH,VHA7,VHH4,VHQ4,VMB3,VMS4 VMS7,VMT,VPM4,VPM5,VPM7,VPR4,VPR7,VS,VSD,VSD1,VSD7,VSX,VSX1 VSX3,VS1,VS17,VD,VD1,VTE2,VTU1,VTX,VTX1,VVA,VWA2,VW12,VX,VXD VXD1,VXE,VXE4,VXE6,VXE7,VXG,VXM,VXU,VXU1,VXW,VXW1,VXW2,VX2 VX26,VX4,WDA6,WJP,WKD6,WKT2,WKT4,WKT6,WMB0,WME2,WME4,WMT
			1	-	-	-	-----	5551817 SWG4
			1	-	-	-	-----	5641954 STM
			1	-	-	-	-----	6219318 QT
			-	(1)	1	1		



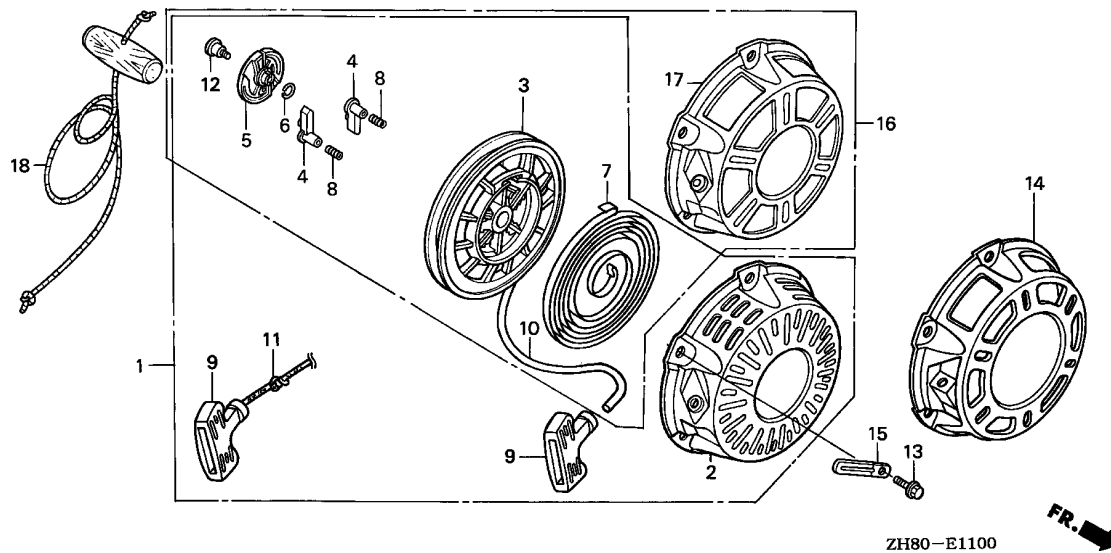

ZH80-E1100



Ref. No.	Part No.	Description	Reqd. QTY				Serial No.	Parts catalogue code
			(1)	(2)	(3)	(4)		
8	28443-ZH8-003	SPRING, RETURN	2	-	-	-	AR,ARC6,BL,DS,DSP,EMA,EMA2,EN,ET,ETX,HG1,HG12,HH,HHQ4,HH26,HX,HXE,HXE2,HXE8,HXQ,HXU,HX2,HX26,HX4,KR,KTA,LAX,LAX2,LD,LDB1,LDB3,LDM,LD4,LH,LHB3,LHQ4,LHW,LJ,LJC7,LJD,LJG,LSJ,LSJ4,LSS,LSS1,LSS4,LTA,LTK,LW2,LX,LXU,LX2,LX26,LX4,NJ,NJC1,NJG,NSJ,NWPH,PHM,PHU,PM,PM2,PX,PXU,PX2,QA,QAB1,QAB3,QAX,QAX2,QA2,QA26,QBC2,QBT2,QBT6,QBU2,QCB2,QCL,QD,QE,QFE4,QGR2,QGR9,QH,QHE,QHP1,QHQ4,QH26,QI2,QKA4,QM,QMC6,QMC8,QMD6,QME4,QMH,QMX2,QMZ2,QNT,QNT2,QNT4,QNZ,QP,QPU,QSC2,QSC9,QS2,QWA4,QWM2,QWX2,QWX3,QX,QXB,QXB1,QXC,QXC6,QXC9,QXE,QXE2,QXE4,QXE6,QXE8,QXF,QXF2,QXM1,QXQ,QXS,QXS2,QXU,QXW,QXW2,QX2,QX22,QX26,QX4,QX7,QZ,RAC,RD,RD4,REX4,RFR,RFR2,RH,RHA,RHA2,RHQ4,RH2,RH26,RMB4,RMD,RMG2,RNG,RSK,RSS1,RTB2,RX,RXE,RXE2,RXE4,RXU,RX4,SAC,SAD2,SCJ,SD,SDB1,SDB3,SDN,SDS,SDS2,SDS3,SD16,SD4,SE,SEE,SG24,SH,SHM,SHQ4,SHRY,SHR4,SJ,SJC,SJC1,SJC5,SJG,SMB4,SMC7,SMC9,SMJ,SMJ1,SMW2,SMX4,SM11,SM12,SM14,SNX,SNX1,SSK1,SSK2,SSX2,ST,STA,STP,STQ,SWX,SWX2,SWX4,SW2,SX,SXB,SXE,SXE4,SXS4,SXU,SX4,SX7,S1CY,TCS2,TH,THU,TX,TXC9,TXU,TX2,TX26,TX4,UH,UX,UXU,VA,VA2,VEBM,VEB2,VED,VED1,VED2,VED3,VED5,VED6,VED7,VEN2,VES,VGE4,VG24,VH,VHA7,VHH4,VHQ4,VMB3,VMS4,VMS7,VMT,VPM4,VPM5,VPM7,VPR4,VPR7,VS,VSD,VSD1,VSD7,VSX,VSX1,VSX3,VS1,VS17,VTD,VTD1,VTE2,VTU1,VTX,VTX1,VVA,VVA2,VW12,VX,VXD,VXD1,VXE,VXE4,VXE6,VXE7,VXG,VXM,VXU,VXU1,VXW,VXW1,VXW2,VX2,VX26,VX4,WDA6,WJP,WKD6,WKT2,WKT4,WKT6,WMB0,WME2,WME4,WMT	
			2	-	-	-	5551817 SWG4	
			2	-	-	-	5641954 STM	
			2	-	-	-	6219318 QT	
			-	(2)	2	2		

Ref. No.	Part No.	Description	Reqd. QTY				Serial No.	Parts catalogue code
			(1)	(2)	(3)	(4)		
9	28461-ZH8-003	GRIP, STARTER	1	-	-	-	AR,ARC6,BL,DS,DSP,EMA,EMA2,EN,ET,ETX,HG1,HG12,HH,HHQ4,HH26,HX HXE,HXE2,HXE8,HXQ,HXU,HX2,HX26,HX4,KR,KTA,LAX,LAX2,LD,LDB1 LDB3,LDM,LD4,LH,LHB3,LHQ4,LHW,LJ,LJC7,LJD,LJG,LSJ,LSJ4,LSS LSS1,LSS4,LTA,LTK,LW2,LX,LXU,LX2,LX26,LX4,NJ,NJC1,NJG,NSJ,NW PH,PHM,PHU,PM,PM2,PX,PXU,PX2,QA,QAB1,QAB3,QAX,QAX2,QA2,QA26 QBC2,QBT2,QBT6,QBU2,QCB2,QCL,QD,QE,QFE4,QGR2,QGR9,QH,QHE,QHP1 QHQ4,QH26,QI2,QKA4,QM,QMC6,QMC8,QMD6,QME4,QMH,QMX2,QM22,QNT QNT2,QNT4,QNZ,QP,QPU,QSC2,QSC9,QS2,QWA4,QWM2,QWX3,QX,QXB QXB1,QXC,QXC6,QXC9,QXE,QXE2,QXE4,QXE6,QXE8,QXF,QXF2,QXM1,QXQ QXS,QXS2,QXU,QXW,QXW2,QX2,QX22,QX26,QX4,QX7,QZ,RAC,RD,RD4,REX4 RFR,RFR2,RH,RHA,RHA2,RHQ4,RH2,RH26,RMB4,RMD,RMG2,RNG,RSK,RSS1 RTB2,RX,RXE,RXE2,RXE4,RXU,RX4,SAC,SAD2,SCJ,SD,SDB1,SDB3,SDN SDS,SDS2,SDS3,SD16,SD4,SE,SEE,SG24,SH,SHM,SHQ4,SHRY,SHR4,SJ SJC,SJC1,SJC5,SJG,SMB4,SMC7,SMC9,SMJ,SMJ1,SMW2,SMX4,SM11,SM12 SM14,SNX,SNX1,SSK1,SSK2,SSX2,ST,STA,STP,STQ,SWX,SWX2,SWX4,SW2 SX,SXB,SXE,SXE4,SXS4,SXU,SX4,SX7,S1CY,TCS2,TH,THU,TX,TXC9,TXU TX2,TX26,TX4,UH,UX,UXU,VA,VA2,VEBM,VEB2,VED,VED1,VED2,VED3 VED5,VED6,VED7,VEN2,VES,VGE4,VG24,VH,VHA7,VHH4,VHQ4,VMB3,VMS4 VMS7,VMT,VPM4,VPM5,VPM7,VPR4,VPR7,VS,VSD,VSD1,VSD7,VSX,VSX1 VSX3,VS1,VS17,VTD,VTD1,VTE2,VTU1,VTX,VTX1,VVA,VWA2,VW12,VX,VXD VXD1,VXE,VXE4,VXE6,VXE7,VXG,VXM,VXU,VXU1,VXW,VXW1,VXW2,VX2 VX26,VX4,WDA6,WJP,WKD6,WKT2,WKT4,WKT6,WMB0,WME2,WME4,WMT	
			1	-	-	-	5551817 SWG4	
			1	-	-	-	5641954 STM	
			1	-	-	-	6219318 QT	
			-	(1)	1	1		
10	28462-ZH8-003	ROPE, RECOIL STARTER	1	-	-	-	AR,ARC6,BL,DS,DSP,EMA,EMA2,EN,ET,ETX,HH,HHQ4,HH26,HX,HXE,HXE2 HXE8,HXQ,HXU,HX2,HX26,HX4,KR,KTA,LAX,LAX2,LD,LDB1,LDB3,LDM,LD4 LH,LHB3,LHQ4,LHW,LJ,LJC7,LJD,LJG,LSJ,LSJ4,LSS,LSS1,LSS4,LTA LTK,LW2,LX,LXU,LX2,LX26,LX4,NJ,NJC1,NJG,NSJ,NW,PH,PHM,PHU,PM PM2,PX,PXU,PX2,QA,QAB1,QAB3,QAX,QAX2,QA2,QA26,QBC2,QBT2,QBT6 QBU2,QCB2,QCL,QD,QE,QFE4,QGR2,QGR9,QH,QHE,QHP1,QHQ4,QH26,QI2 QKA4,QM,QMC6,QMC8,QMD6,QME4,QMH,QMX2,QM22,QNT,QNT2,QNT4,QNZ,QP QPU,QSC2,QS2,QWA4,QWM2,QWX2,QWX3,QX,QXB,QXB1,QXC,QXC6,QXC9,QXE QXE2,QXE4,QXE6,QXE8,QXF,QXF2,QXM1,QXQ,QXS,QXS2,QXU,QXW,QXW2 QX2,QX22,QX26,QX4,QX7,QZ,RAC,RD,RD4,REX4,RFR,RFR2,RH,RHA,RHA2 RHQ4,RH2,RH26,RMB4,RMD,RMG2,RNG,RSK,RSS1,RTB2,RX,RXE,RXE2,RXE4 RXU,RX4,SAC,SAD2,SCJ,SD,SDB1,SDB3,SDN,SDS,SDS2,SDS3,SD16,SD4 SE,SEE,SG24,SH,SHM,SHQ4,SHRY,SHR4,SJ,SJC,SJC1,SJC5,SJG,SMB4 SMC7,SMC9,SMJ,SMJ1,SMW2,SMX4,SM11,SM12,SM14,SSK1,SSK2,SSX2,ST STA,STP,STQ,SWX,SWX2,SWX4,SW2,SX,SXB,SXE,SXE4,SXS4,SXU,SX4,SX7 S1CY,TCS2,TH,THU,TX,TXC9,TXU,TX2,TX26,TX4,UH,UX,UXU,VA,VA2 VEBM,VEB2,VED,VED1,VED2,VED3,VED5,VED6,VED7,VEN2,VES,VGE4,VG24 VH,VHA7,VHH4,VHQ4,VMB3,VMS4,VMS7,VMT,VPM4,VPM5,VPM7,VPR4,VPR7 VS,VSD,VSD1,VSD7,VSX,VSX1,VSX3,VS1,VS17,VTD,VTD1,VTE2,VTU1,VTX VTX1,VVA,VWA2,VW12,VX,VXD,VXD1,VXE,VXE4,VXE6,VXE7,VXG,VXM,VXU VXU1,VXW,VXW1,VXW2,VX2,VX26,VX4,WDA6,WJP,WKD6,WKT2,WKT4,WKT6 WMB0,WME2,WME4,WMT	
			1	-	-	-	2828660 HG1	
			1	-	-	-	5551817 SWG4	
			1	-	-	-	5641954 STM	
			1	-	-	-	6219318 QT	
			-	(1)	1	1		
	28462-ZH8-R10		1	-	-	-	HG12,SNX,SNX1	
			1	-	-	2828661	HG1	

2

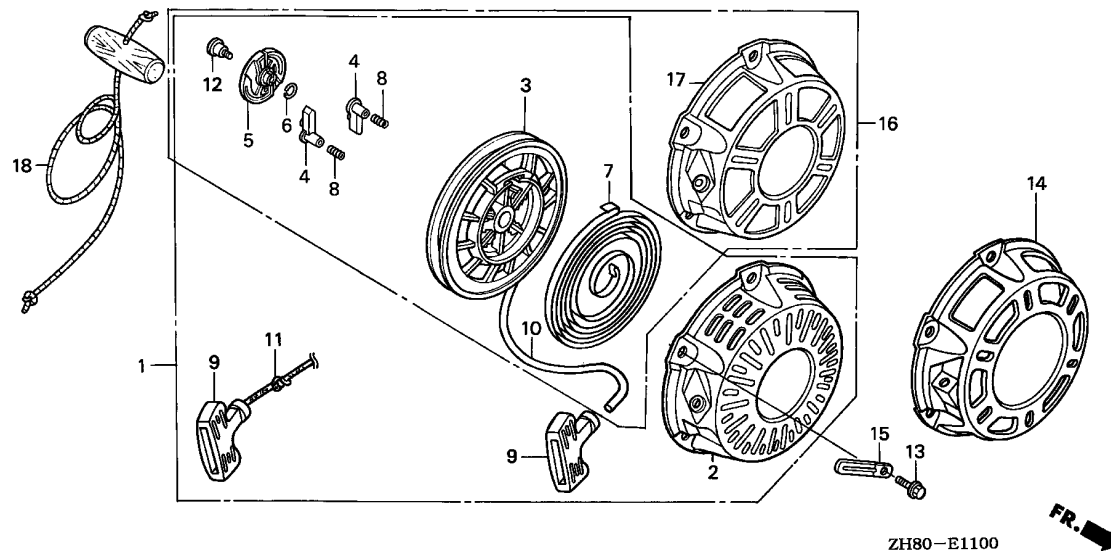

ZH80-E1100



Ref. No.	Part No.	Description	Reqd. QTY				Serial No.	Parts catalogue code
			(1)	(2)	(3)	(4)		
			GX160K1					
11	28462-ZH8-821	ROPE, RECOIL STARTER (LONG) -	1	-	-	-	-----	QSC9
12	90003-ZH8-003	SCREW, SETTING	1	(1)	-	-	-----	AR,ARC6,BL,DS,DSP,EMA,EMA2,EN,ET,ETX,HG1,HG12,HH,HHQ4,HH26,HX HXE,HXE2,HXE8,HXQ,HXU,HX2,HX26,HX4,KR,KTA,LAX,LAX2,LD,LDB1 LDB3,LDM,LD4,LH,LHB3,LHQ4,LHW,LJ,LJC7,LJD,LJG,LSJ,LSJ4,LSS LSS1,LSS4,LTA,LTK,LW2,LX,LXU,LX2,LX26,LX4,NJ,NJC1,NJG,NSJ,NW PH,PHM,PHU,PM,PM2,PX,PXU,PX2,QA,QAB1,QAB3,QAX,QAX2,QA2,QA26 QBC2,QBT2,QBT6,QBU2,QCB2,QCL,QD,QE,QFE4,QGR2,QGR9,QH,QHE,QHP1 QHQ4,QH26,QI2,QKA4,QM,QMC6,QMC8,QMD6,QME4,QMH,QMX2,QMZ2,QNT QNT2,QNT4,QNZ,QP,QPU,QSC2,QSC9,QS2,QWA4,QWM2,QWX2,QWX3,QX,QXB QXB1,QXC,QXC6,QXC9,QXE,QXE2,QXE4,QXE6,QXE8,QXF,QXF2,QXM1,QXQ QXS,QXS2,QXU,QXW,QXW2,QX2,QX22,QX26,QX4,QX7,QZ,RAC,RD,RD4,REX4 RFR,RFR2,RH,RHA,RHA2,RHQ4,RH2,RH26,RMB4,RMD,RMG2,RNG,RSK,RSS1 RTB2,RX,RXE,RXE2,RXE4,RXU,RX4,SAC,SAD2,SCJ,SD,SDB1,SDB3,SDN SDS,SDS2,SDS3,SD16,SD4,SE,SEE,SG24,SH,SHM,SHQ4,SHRY,SHR4,SJ SJC,SJC1,SJC5,SJG,SMB4,SMC7,SMC9,SMJ,SMJ1,SMW2,SMX4,SM11,SM12 SM14,SNX,SNX1,SSK1,SSK2,SSX2,ST,STA,STP,STQ,SWX,SWX2,SWX4,SW2 SX,SXB,SXE,SXE4,SXS4,SXU,SX4,SX7,S1CY,TCS2,TH,THU,TX,TXC9,TXU TX2,TX26,TX4,UH,UX,UXU,VA,VA2,VEBM,VEB2,VED,VED1,VED2,VED3 VED5,VED6,VED7,VEN2,VES,VGE4,VG24,VH,VHA7,VHH4,VHQ4,VMB3,VMS4 VMS7,VMT,VPM4,VPM5,VPM7,VPR4,VPR7,VS,VSD,VSD1,VSD7,VSX,VSX1 VSX3,VS1,VS17,VTD,VTD1,VTE2,VTU1,VTX,VTX1,VVA,VVA2,VW12,VX,VXD VXD1,VXE,VXE4,VXE6,VXE7,VXG,VXM,VXU,VXU1,VXW,VXW1,VXW2,VX2 VX26,VX4,WDA6,WJP,WKD6,WKT2,WKT4,WKT6,WMB0,WME2,WME4,WMT
			1	-	-	-	-----	5551817 SWG4
			1	-	-	-	-----	5641954 STM
			1	-	-	-	-----	6219318 QT
			-	(1)	1	1		

Ref. No.	Part No.	Description	Reqd. QTY				Serial No.	Parts catalogue code
			(1)	(2)	(3)	(4)		
13	95701-06008-00	BOLT, FLANGE, 6X8	3	(3)	-	3	-----	DS,DSP,EMA,EN,ET,ETX,HG1,HXQ,H1,LAX,LAX2,LDM,LD4,LJC7,LJD,LSJ LSS,LSS1,LSS4,LTA,LTk,PH,PHU,PM,PM2,PX,PX2,QAX,QBT2,QBU2,QNT2 QWM2,QXB,QXB1,QXF,QXQ,QXS,QZ,RAC,REX4,RFR,RHA,SAC,SAD2,SDB1 SDS2,SDS3,SEE,SJC,SMB4,SSK2,STA,STM,STP,SWX,SW2,SXP1,TH,T1,U1 VA,VEB2,VED7,VHQ4,VSX1,VSX3,VS1,VTE2,VVA,VXD1,VXE,VXE6,VXP,VXW VXW1,VX26,V1
			3	-	-	-	-----	2438430 VS,VSX
			3	-	-	-	-----	6219318 QT
	90008-ZE2-003	BOLT, FLANGE, 6X10	3	(3)	-	3	-----	AR,ARC6,BL,EMA2,HG12,HH,HHQ4,HH26,HX,HXE,HXE2,HXE8,HXU,HX2 HX26,HX4,KR,KTA,LD,LDB1,LDB3,LH,LHB3,LHQ4,LHW,LJ,LJG,LSJ4,LW2 LX,LXU,LX2,LX26,LX4,L1,NJ,NJC1,NJG,NSJ,NW,PHM,PXU,QA,QAB1,QAB3 QAX2,QA2,QA26,QBC2,QBT6,QCB2,QCL,QD,QE,QFE4,QGR2,QGR9,QH,QHE QHP1,QHQ4,QH26,QI2,QKA4,QM,QMC6,QMC8,QMD6,QME4,QMH,QMX2,QM2 QNT,QNT4,QNZ,QP,QPU,QSC2,QSC9,QS2,QWA4,QWX2,QWX3,QX,QXC,QXC6 QXC9,QXE,QXE2,QXE4,QXE6,QXE8,QXF2,QXM1,QXS2,QXU,QXW,QXW2,QX2 QX22,QX26,QX4,QX7,Q1,RD,RD4,RFR2,RH,RHA2,RHQ4,RH2,RH26,RMB4 RMD,RMG2,RNG,RSK,RSS1,RTB2,RX,RXE,RXE2,RXE4,RXU,RX4,R1,SCJ,SD SDB3,SDN,SDS,SD16,SD4,SE,SG24,SH,SHM,SHQ4,SHRY,SHR4,SJ,SJC1 SJC5,SJG,SMC7,SMC9,SMJ,SMJ1,SMW2,SMX4,SM11,SM12,SM14,SNX,SNX1 SSK1,SSX2,ST,STM,STQ,SWG4,SWX2,SWX4,SX,SBX,SXE,SXE4,SXS4,SXU SX4,SX7,S1,S1CY,TCS2,THU,TX,TXC9,TXU,TX2,TX26,TX4,UH,UX,UXU VA2,VEBM,VED,VED1,VED2,VED3,VED5,VED6,VEN2,VES,VGE4,VG24,VH VHA7,VHH4,VMB3,VMS4,VMS7,VMT,VPM4,VPM5,VPM7,VPR4,VPR7,VSD,VSDP VSD1,VSD7,VS17,VD,VD1,VTU1,VTX,VTX1,VWA2,VW12,VX,VXD,VXE4 VXE7,VXG,VXM,VXU,VXU1,VXW2,VX2,VX4,WDA6,WJP,WKD6,WKT2,WKT4 WKT6,WMB0,WME2,WME4,WMT,W1
			-	-	3	-		
14	28414-ZH8-841ZB	CASE B, STARTER	1	-	-	-	-----	STM
	28414-ZK8-V70	*R8*.....BRIGHT RED	1	-	-	-	-----	5551818 8410466 SWG4
	28414-ZK8-V71	1	-	-	-	-----	8410467 SWG4
15	32901-MA1-000	CLIP, SUB CORD	1	-	-	-	-----	SM14
			1	-	-	-	-----	6171260 SM11,SM12
16	28400-ZH8-D52	STARTER ASSY., RECOIL	1	-	-	-	-----	NJC1
17	28410-ZH8-D51	CASE COMP., RECOIL STARTER ..	1	-	-	-	-----	NJC1
18	28470-816-000	ROPE, STARTER	-	(1)	-	-		

2

E-11-1

RECOIL STARTER(2)

J13

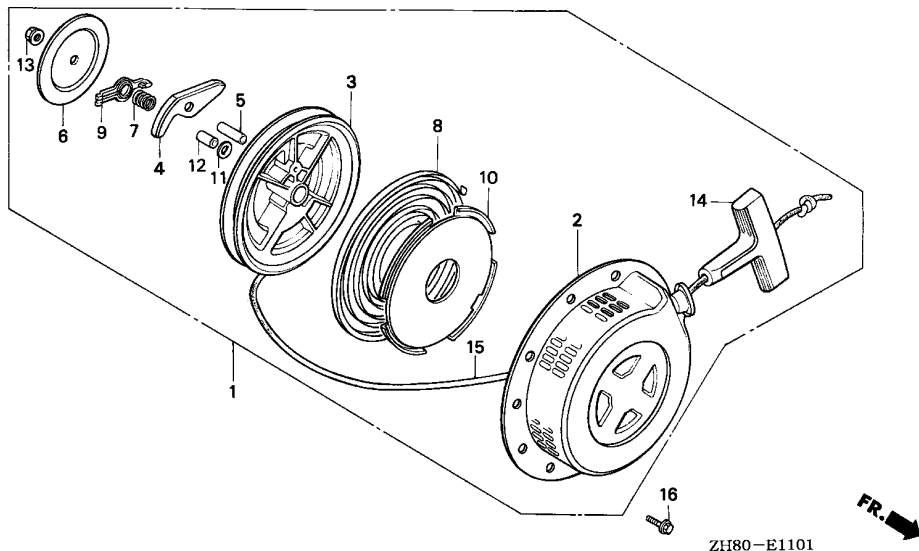

Ref. No.	L.O.N.	(Relative ref. Number) Description	F.R.T.
1	1121B9	STARTER, RECOIL	0.1
3	1121C9	REEL, RECOIL STARTER(A)	0.4
4	1121B0	RATCHET, STARTER AND/OR SPRING, RATCHET	0.2
8	1121D1	SPRING, RECOIL STARTER RETURN (A)	0.4
9	1121A4	GUIDE, RATCHET	0.2
15	1121D0	ROPE, RECOIL STARTER(A)	0.4

2

ZH80-E1101

Ref. No.	Part No.	Description	Reqd. QTY				Serial No.	Parts catalogue code
			(1)	(2)	(3)	(4)		
			GX160K1					
1	28400-ZB2-000ZB	STARTER ASSY., RECOIL	1	-	-	-		
		R8.....BRIGHT RED	1	-	-	-	VSB1,VSG,VSW,VS3,VS4	
	28400-ZB2-000ZD	*NH1*.....BLACK	1	-	-	-	VS3	
	28400-ZB2-000ZE	*Y131*.....LIGHTNING YELLOW	1	-	-	-	VS3,VS4	
	28400-ZB2-000ZF	*T77*.....SEC WINE RED	1	-	-	-	VS3,VS4	
	28400-ZB2-000ZG	*T80*.....BAKELITE ORANGE	1	-	-	-	VS3	
	28400-ZE1-003ZA	*R8*.....BRIGHT RED	1	-	-	-	LVL,QVL	
			1	-	-	-	6219319	QT
2	28410-ZB2-000ZB	CASE COMP., RECOIL STARTER	1	-	-	-		
		R8.....BRIGHT RED	1	-	-	-	VSB1,VSG,VSW,VS3,VS4	
	28410-ZB2-000ZE	*NH1*.....BLACK	1	-	-	-	VS3	
	28410-ZB2-000ZF	*Y131*.....LIGHTNING YELLOW	1	-	-	-	VS3,VS4	
	28410-ZB2-000ZG	*T77*.....SEC WINE RED	1	-	-	-	VS3,VS4	
	28410-ZB2-000ZH	*T80*.....BAKELITE ORANGE	1	-	-	-	VS3	
	28410-ZE1-003ZA	*R8*.....BRIGHT RED	1	-	-	-	LVL,QVL	
			1	-	-	-	6219319	QT
3	28420-ZE1-003	PULLEY, RECOIL STARTER	1	-	-	-		
			1	-	-	-	LVL,QVL,VSB1,VSG,VSW,VS3,VS4	
			1	-	-	-	6219319	QT
4	28422-ZE1-003	RATCHET, STARTER	1	-	-	-		
			1	-	-	-	LVL,QVL,VSB1,VSG,VSW,VS3,VS4	
			1	-	-	-	6219319	QT
5	28423-ZE1-003	PIN, STARTER RATCHET	1	-	-	-		
			1	-	-	-	LVL,QVL,VSB1,VSG,VSW,VS3,VS4	
			1	-	-	-	6219319	QT
6	28431-ZE1-003	PLATE, FRICTION	1	-	-	-		
			1	-	-	-	LVL,QVL,VSB1,VSG,VSW,VS3,VS4	
			1	-	-	-	6219319	QT
7	28441-ZE1-003	SPRING, FRICTION	1	-	-	-		
			1	-	-	-	LVL,QVL,VSB1,VSG,VSW,VS3,VS4	
			1	-	-	-	6219319	QT

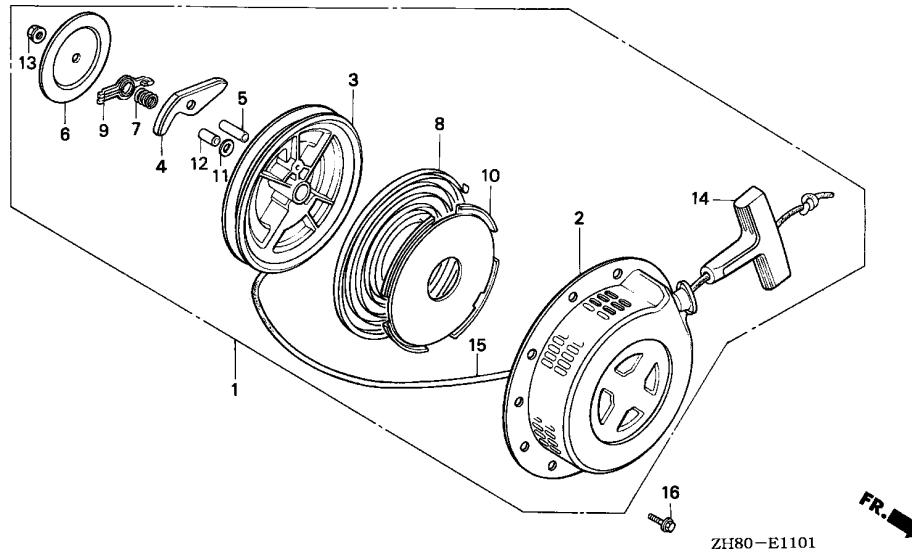

Ref. No.	Part No.	Description	Reqd. QTY				Serial No.	Parts catalogue code
			(1)	(2)	(3)	(4)		
8	28442-ZE1-003	SPRING, RECOIL STARTER	1	-	-	-	LVL,QVL,VS1,VSG,VSW,VS3,VS4	
9	28443-ZE1-003	GUIDE, RATCHET	1	-	-	6219319	QT	
10	28445-ZE1-003	CASE, RECOIL STARTER SPRING	1	-	-	6219319	LVL,QVL,VS1,VSG,VSW,VS3,VS4	
			1	-	-	6219319	QT	
11	28446-ZE1-003	WASHER, STARTER	1	-	-	-	LVL,QVL,VS1,VSG,VSW,VS3,VS4	
12	28447-ZE1-003	SHAFT, SUB	1	-	-	6219319	QT	
13	28448-ZE1-003	NUT	1	-	-	-	LVL,QVL,VS1,VSG,VSW,VS3,VS4	
			1	-	-	6219319	QT	
14	28461-ZE1-003	KNOB, RECOIL STARTER	1	-	-	-	LVL,QVL,VS1,VSG,VSW,VS3,VS4	
			1	-	-	6219319	QT	
15	28462-ZE1-003	ROPE, RECOIL STARTER	1	-	-	-	LVL,QVL,VS1,VSG,VSW,VS3,VS4	
			1	-	-	6219319	QT	
16	90008-ZE2-003	BOLT, FLANGE, 6X10	3	-	-	-	LVL,QVL,VS1,VSG,VS3,VS4	
			3	-	-	6219319	QT	
	95701-06008-00	BOLT, FLANGE, 6X8	3	-	-	-	VSW	

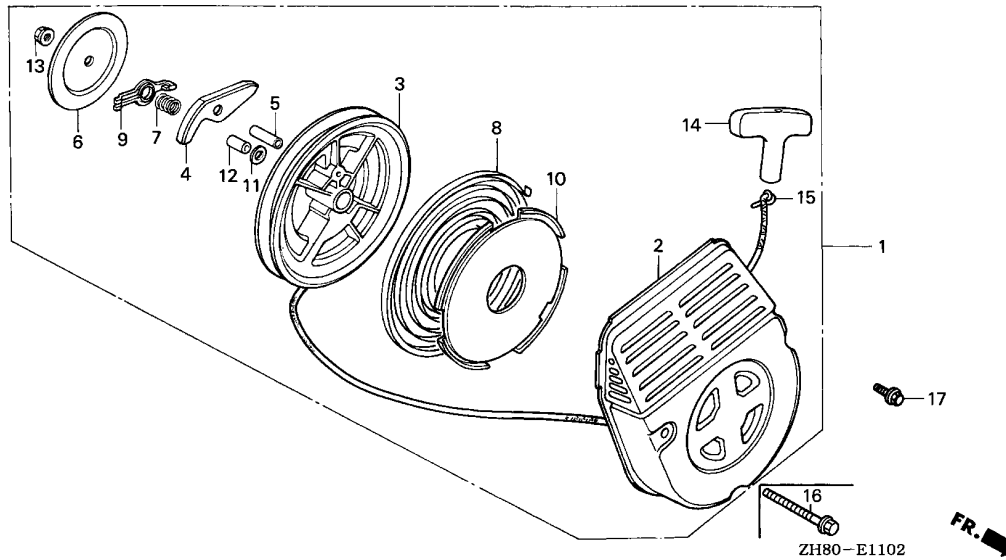

Ref. No.	L.O.N.	(Relative ref. Number) Description	F.R.T.
1	1121B9	STARTER, RECOIL	0.1
3	1121B1	REEL, RECOIL STARTER	0.3
4	1121B0	RATCHET, STARTER AND/OR SPRING, RATCHET	0.2
8	1121D1	SPRING, RECOIL STARTER RETURN (A)	0.4
9	1121A4	GUIDE, RATCHET	0.2
15	1121B3	ROPE, RECOIL STARTER	0.3

2

Ref. No.	Part No.	Description	Reqd. QTY				Serial No.	Parts catalogue code
			(1)	(2)	(3)	(4)		
1	28400-ZH8-U81ZA	STARTER ASSY., RECOIL (MAMETORA)						
		R8.....BRIGHT RED	1	-	-	-	-----	LMT
	28400-734-003ZA	STARTER ASSY., RECOIL						
		R8.....BRIGHT RED	1	-	-	-	-----	LJS
2	28410-734-000ZA	CASE COMP., RECOIL STARTER						
		R8.....BRIGHT RED	1	-	-	-	-----	LJS
	28410-735-003ZA	*R8*.....BRIGHT RED	1	-	-	-	-----	LMT
3	28420-ZE1-003	PULLEY, RECOIL STARTER	1	-	-	-	-----	LJS,LMT
4	28422-ZE1-003	RATCHET, STARTER	1	-	-	-	-----	LJS,LMT
5	28423-ZE1-003	PIN, STARTER RATCHET	1	-	-	-	-----	LJS,LMT
6	28431-ZE1-003	PLATE, FRICTION	1	-	-	-	-----	LJS,LMT
7	28441-ZE1-003	SPRING, FRICTION	1	-	-	-	-----	LJS,LMT
8	28442-ZE1-003	SPRING, RECOIL STARTER	1	-	-	-	-----	LJS,LMT
9	28443-ZE1-003	GUIDE, RATCHET	1	-	-	-	-----	LJS,LMT
10	28445-ZE1-003	CASE, RECOIL STARTER SPRING	1	-	-	-	-----	LJS,LMT
11	28446-ZE1-003	WASHER, STARTER	1	-	-	-	-----	LJS,LMT
12	28447-ZE1-003	SHAFT, SUB	1	-	-	-	-----	LJS,LMT
13	28448-ZE1-003	NUT	1	-	-	-	-----	LJS,LMT
14	28461-ZE1-003	KNOB, RECOIL STARTER	1	-	-	-	-----	LJS,LMT
15	28462-ZE1-003	ROPE, RECOIL STARTER	1	-	-	-	-----	LJS,LMT
16	95700-06050-00	BOLT, FLANGE, 6X50	1	-	-	-	-----	LJS
17	95701-06008-00	BOLT, FLANGE, 6X8	3	-	-	-	-----	LMT
	90008-ZE2-003	BOLT, FLANGE, 6X10	2	-	-	-	-----	LJS

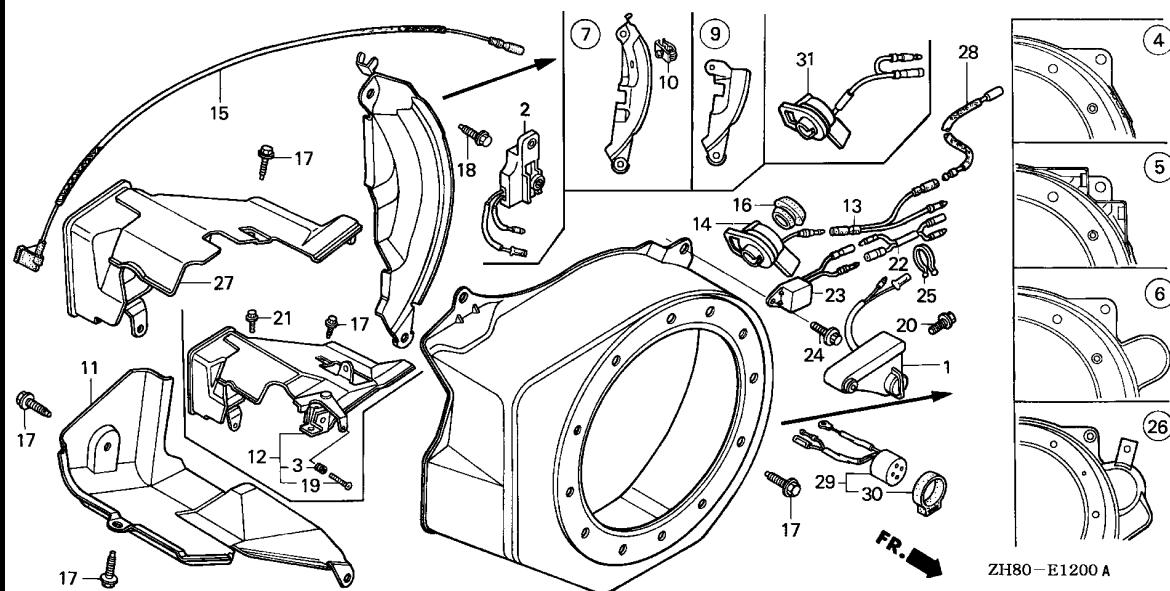

ZH80-E1200 A

Ref. No.	L.O.N.	(Relative ref. Number) Description	F.R.T.
1	6151C6	SWITCH, OIL ALERT UNIT (5,6,26)	0.1
4	1141G8	COVER, ENGINE COOLING FAN (9)	0.2
7	1121A7	PLATE, SIDE	0.3
11	4141E0	SHROUD, ENGINE :LOWER	0.2
13	6111A3	CORD, ENGINE STOP SWITCH	0.1
14	6151D9	SWITCH, ENGINE STOP	0.2
15	6111B3	CORD, STOP SWITCH	0.3
22	6141C5	CABLE, DOUBLE CONNECTOR	0.1
23	6151A0	ALERT UNIT, OIL	0.1
27	4141E2	SHROUD, ENGINE :UPPER	0.2
29	6211C3	BUZZER, WARNING	0.1

Ref. No.	Part No.	Description	Reqd. QTY				Serial No.	Parts catalogue code
			(1)	(2)	(3)	(4)		
1	15520-ZE1-003	ALERT UNIT, OIL	1	-	-	-	2468252 HG1,HX,LX,PX,QNT,QX,QXC,QXF,QXS,RX,SMJ,SMJ1,SWX,SX,TX,UX,VA	
							VEBM,VED1,VSD,VSD1,VSX,VX,VXW	
2	15520-ZE1-822	ALERT UNIT, OIL	1	(1)	-	-	2468252	
	15520-ZB2-003	1	-	-	-	2468252 ETX	
3	16584-883-300	SPRING, CONTROL ADJUSTING ...	1	-	-	-	2468252 VS3	
							EMA,EMA2,VED2,VED3,VED7,VEN2,VES,VMT,VSB1,VSG,VSX,VS4,VTE2	
							VTX,VTX1	



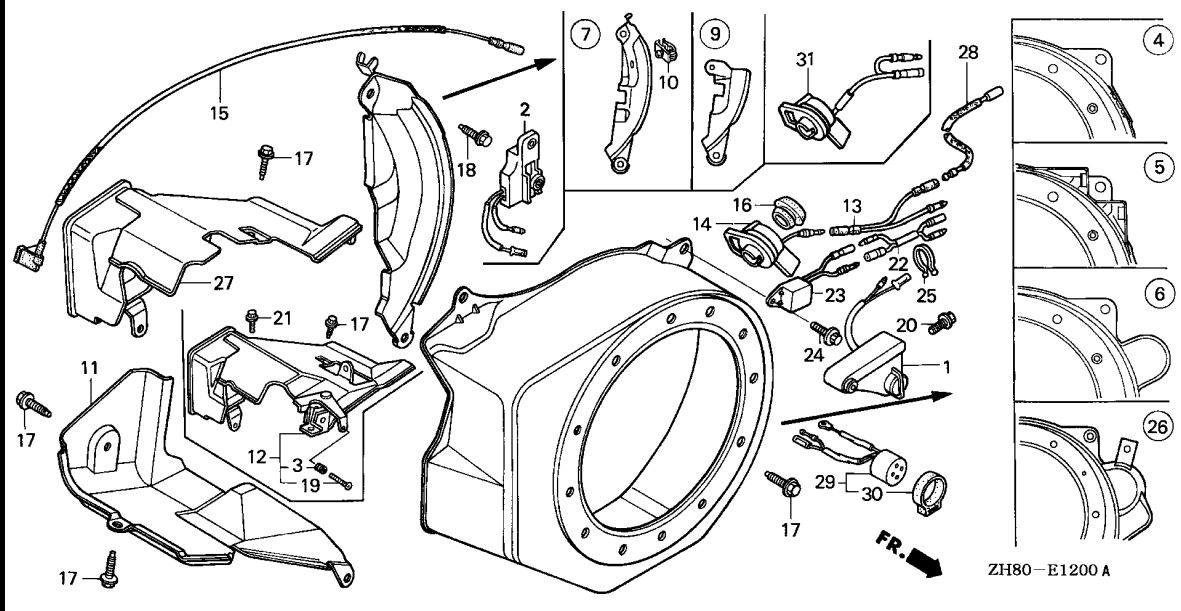

ZH80-E1200 A

Ref. No.	Part No.	Description	Reqd. QTY				Serial No.	Parts catalogue code
			(1)	(2)	(3)	(4)		
4	19610-ZE1-000ZA	COVER COMP., FAN *R8*.....BRIGHT RED	1	-	-	-	-----	BL,DS,DSP,EN,ET,ETX,HG12,HHQ4,HH26,HXQ,HXU,HX26,HX4,LAX,LAX2,LDB1,LDB3,LDM,LD4,LHB3,LHQ4,LHW,LJC7,LJD,LMT,LSS,LTA,LTk,LVL,LXU,LX26,LX4,NSJ,NW,PH,PHM,PM,PM2,PXU,PX2,QA,QAB1,QAB3,QAX,QAX2,QA26,QBC2,QBT6,QBU2,QCB2,QE,QFE4,QGR9,QHP1,QHQ4,QH26,QM,QMC6,QMC8,QMD6,QME4,QMH,QMX2,QMZ2,QNT2,QNT4,QP,QPU,QSC9,QVL,QWA4,QXB,QXB1,QXC6,QXC9,QXM1,QXQ,QXU,QX26,QX4,QX7,QZ,RAC,RD4,RFR,RFR2,RHA,RHA2,RHQ4,RH26,RMB4,RMG2,RNG,RSS1,RTB2,RXU,RX4,SAC,SAD2,SDB1,SDB3,SDN,SDS2,SDS3,SD16,SD4,SE,SHM,SHQ4,SHR4,SJC,SMB4,SMC7,SMC9,SMW2,SM11,SM12,SM14,SNX,STA,STM,STP, SXB,SXS4,SXU,SX4,SX7,S1CY,TCS2,TH,TXC9,TXU, TX26, TX4,UH,UXU,VA2,VEB2,VED5,VGE4,VH,VHH4,VHQ4,VMB3,VMS4,VMS7,VMT,VPM4,VPM7,VPR4,VPR7,VS, VSB1,VSD7,VSG,VSX3,VS1,VS4,VTD,VTE2,VTU1,VVA,VXG,VXM,VXU1,VXW2,VX26,VX4,WJP,WKT2,WKT4,WKT6,WMB0,WME2,WME4,WMT
			1	-	-	-	2468253	HG1,QXC,QXF,QXS,SWX,UX,VA,VXW
			1	-	-	-	6481740	SHRY
			1	-	-	-	8369925	HH,HX2,KTA,LD,LH,LJ,LJG,LJS,LX2,NJ,NJG,QA2,QCL,QD,QGR2,QH,QI2,QT,QXF2,QXS2,QX2,QX22,RD,RH,RH2,RMD,RSK,SCJ,SD,SH,SJ,SJG,SMX4,STQ, TX2, VED, VED2, VED3, VSX1, VS3, VXU, VX2, WDA6, WKD6
			1	-	-	-	2468253	2744590 VSD1
			1	-	-	-	2468253	8369925 HX,LX,PX,QNT,QX,RX,SMJ,SMJ1,SX, TX, VEBM, VED1, VSD, VSX, VX
			-	(1)	1	1		
	19610-ZE1-000ZC	*NH1*.....BLACK	1	-	-	-	-----	EMA,EMA2,HXQ,HX2,LX2,PX2,QA2,QBU2,QCB2,QMC8,QMX2,QMZ2,QNT2,QSC9,QWM2,QXC9,QXF2,QXQ,QXS2,QX2,QX4,RD,RH2,SG24,SMB4,SMX4,SM12,SM14,SSK1,SSK2,SSX2, TX2, TX4, VED, VED1, VED2, VED6, VED7, VEN2, VG24, VS3, VVA2, VXD, VXD1, VXW2, VX2
	19610-ZE1-000ZD	*T39*.....GEKO BLUE	1	-	-	-	-----	VMB3, VX4
	19610-ZE1-000ZF	*T41*...BARTELL BLUE METALLIC	1	-	-	-	-----	QBT2,QBT6,QX2,QX4

Ref. No.	Part No.	Description	Reqd. QTY				Serial No.	Parts catalogue code
			GX160K1 (1)	(2)	(3)	(4)		
(4)	19610-ZE1-000ZG	COVER COMP., FAN						
	NH105	MAT BLACK (#15-#20)	1	-	-	-	QWX2,QWX3,SWX2,SWX4,VSD7,VWA2,VW12,VXW1,VX4	
	19610-ZE1-000ZK	*T68*	1	-	-	-	VED2	
	19610-ZE1-000ZL	*Y131*	1	-	-	-	VED2,VSX1,VS3,VS4	
	19610-ZE1-000ZM	*T77*	1	-	-	-	VSX,VSX1,VS3,VS4	
	19610-ZE1-000ZN	*T80*	1	-	-	-	VS3, VTD, VTD1, VTX, VTX1	
	19610-ZH8-T50ZA	*R8*	1	-	-	-	PHU, THU	
	19610-ZK8-V00ZA	*R8*	1	-	-	-	AR, ARC6, KR	
	19610-ZB2-601ZB	*R8*	1	-	-	-	LSJ, LSS4	
			1	-	-	8382917	LSJ4, SJC1, SJC5	
	19610-ZB6-000		1	-	-	6481741	SHRY	
	19610-ZE1-000ZP	*R280*	1	-	-	-	NJC1	
			1	-	-	-	QS2, VES, VHA7, VPM5	
			1	-	-	8369926	HH, HX, HX2, KTA, LD, LH, LJ, LJG, LJS, LX, LX2, NJ, NJG, PX, QA2, QCL, QD, QGR2, QH, QI2, QNT, QT, QX, QXF2, QXS2, QX2, QX22, RD, RH, RH2, RMD, RSK, RX, SCJ, SD, SDS, SH, SJ, SJG, SMJ, SMJ1, SMX4, STQ, SX, TX, TX2, VEBM, VED, VED1, VED2, VED3, VSD, VSX, VSX1, VS3, VX, VXU, VX2, WDA6, WKD6	
	19610-ZB2-601ZE	*R280*	1	-	-	8382918	LSJ4, SHRY, SJC1, SJC5	
5	19610-ZE1-810ZA	COVER COMP., FAN (OIL ALERT)						
	R8	BRIGHT RED	1	-	-	-	VS17	
			1	-	-	2468252	HG1, HX, LX, PX, QNT, QX, QXC, QXF, QXS, RX, SMJ, SMJ1, SWX, SX, TX, UX, VA, VEBM, VED1, VSD, VSD1, VSX, VX, VXW	
			-	(1)	-	-	2468252	
			1	-	-	2744591	VSD1	
6	19610-ZE1-820ZA	COVER COMP., FAN (STARTER MOTOR)						
	R8	BRIGHT RED	1	-	-	-	LSS1, QNZ, SNX1, ST, STM, SWG4, VSW	
			-	(1)	-	-		
	19610-ZE1-820ZB	*T33*	1	-	-	-	SKM	
7	19611-ZH8-810	PLATE COMP., SIDE (OIL ALERT)	1	(1)	-	5372719	HG12, HX, HX2, HX26, HX4, LJG, LX, LX2, LX26, LX4, L1, PX, PX2, QBT2, QBT6, QGR2, QMC8, QMH, QMX2, QNT, QNT4, QWM2, QWX2, QX, QXB1, QXC, QXC6, QXC9, QXF2, QXM1, QXQ, QX2, QX26, QX4, Q1, RX, RX4, SG24, SJC1, SJC5, SMC7, SMJ, SMJ1, SMW2, SNX, SSS2, SX, SXB, SX4, S1, TX, TXC9, TX2, TX26, TX4, UX, VA2, VEBM, VED1, VED2, VED3, VED5, VED7, VGE4, VG24, VHH4, VMB3, VMS4, VPM4, VPR4, VSB1, VSD, VSD1, VSX, VSX1, VS3, VS4, VTD, VTD1, VTX, VTX1, VWA2, VW12, VX, VXG, VXM, VXU, VXW2, VX2, VX26, VX4, WKT2, WME2, WMT, W1	
			1	-	1	-	HXU, LXU, PXU, QCL, QI2, QS2, QWA4, QWX3, QXU, QX22, QX7, RXU, SMX4, SM12, SM14, SWX2, SWX4, SXS4, SXU, SX7, TCS2, TXU, UXU, VED6, VEN2, VHA7, VIH1, VMS7, VMT, VPM5, VPM7, VPR7, VSD7, VSG, VSX3, VS17, VTU1, VXU1, WKD6, WKT4, WKT6	
			-	-	-	2000069	VSDP, VXP	
	19611-ZH8-820	PLATE COMP., SIDE (ALERT & LAMP)	1	(1)	-	5372719	EMA, EMA2, QAX2, QMD6, QXS2, Q1, SMC9, S1, VXD, VXD1	
			1	-	-	-	QGR9, QSC9, STM, SXP1, VES	
	19612-ZH8-000	PLATE, SIDE (STD.)	1	-	1	-	BL, DS, DSP, EN, ET, HH, HHQ4, HH26, KTA, LD, LDB1, LDB3, LDM, LD4, LH, LH3, LHQ4, LJ, LJD, LJG, LJS, LMT, LSJ, LSJ4, LSS4, LTA, LTK, LVL, NJ, NJC1, NJG, NW, PH, PHM, PHU, PM, PM2, QA, QAB1, QAB3, QA2, QA26, QBC2, QCB2, QD, QE, QFE4, QH, QHP1, QHQ4, QH26, QIH1, QM, QME4, QM22, QPU, QT, QVL, QZ, RAC, RD, RD4, RFR, RFR2, RH, RHQ4, RH2, RH26, RMB4, RMD, RNG, RSS1, RTB2, SAC, SCJ, SD, SDB1, SDB3, SDN, SDS2, SDS3, SD16, SD4, SE, SH, SHM, SHQ4, SHRY, SHR4, SJ, SJC, SJG, SMB4, SM11, SSK1, SSK2, STA, STP, STQ, S1CY, TH, THU, UH, UIH, VED, VH, VH4, VS, VS1, VTE2, WDA6, WIH1, WJP, WMBO, WME4	
			-	(1)	-	-		



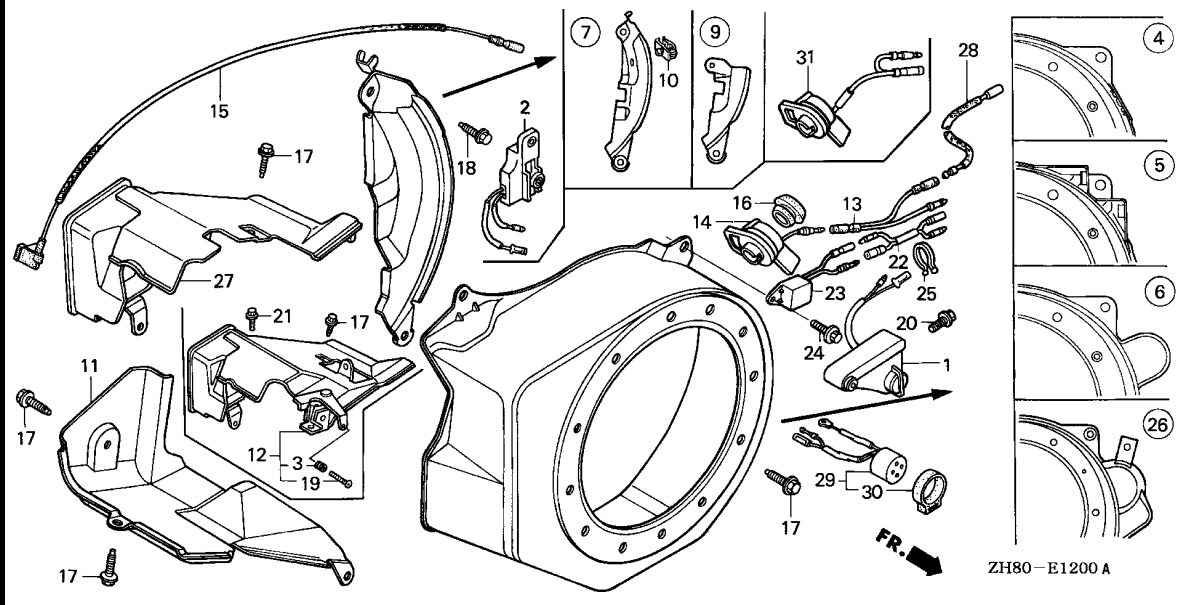

ZH80-E1200 A

Ref. No.	Part No.	Description	Reqd. QTY				Serial No.	Parts catalogue code
			(1)	(2)	(3)	(4)		
			GX160K1					
(7)	19612-ZH8-810	PLATE, SIDE (OIL ALERT)	1	(1)	-	-	4795905	ETX,HG1,HG12,HX,HXQ,HX2,HX26,HX4,LJC7,LX,LX2,LX26,LX4,L1,PX,PX2,QBT2,QBT6,QBU2,QGR2,QMC8,QMH,QMX2,QNT,QNT2,QWM2,QWX2,QX,QXB,QXB1,QXC,QXC6,QXC9,QXF,QXF2,QXQ,QX2,QX26,QX4,RX,RX4,SAD2,SG24,SJC1,SJC5,SMC7,SMJ,SMJ1,SMW2,SNX,SSX2,SWX,SX,SXB,SX4,TX, TXC9, TX2, TX26, TX4, T1, UX, VA, VA2, VEBM, VEB2, VED1, VED2, VED3, VED5, VGE4, VG24, VHH4, VMB3, VMS4, VSD, VSD1, VSX, VSX1, VS3, VS4, VWA, VWA2, VW12, VX, VXG, VXM, VXU, VXW, VXW1, VXW2, VX2, VX26, VX4, V1, WKT2, WME2, WMT, W1
			-	(1)	-	-	2000028	H1,Q1,R1,S1,U1 VSDP,VXP
	19612-ZH8-811	1	(1)	-	-	4795906	ETX,HG1,HXQ,QBU2,QNT2,QXB,QXF,R1,SAD2,SWX,T1,VA,VEB2,VWA,VXW, VXW1, V1
			1	(1)	-	-	4795906	5066322 HG12,HX,HX2,HX26,HX4,LJC7,LX,LX2,LX26,LX4,L1,PX,PX2,QBT2,QBT6, QGR2,QMC8,QMH,QMX2,QNT,QWM2,QWX2,QX,QXB1,QXC,QXC6,QXC9,QXF2, QXQ,QX2,QX26,QX4,Q1,RX,RX4,SG24,SJC1,SJC5,SMC7,SMJ,SMJ1,SMW2, SNX,SSX2,SX,SXB,SX4,S1,TX, TXC9, TX2, TX26, TX4, UX, VA2, VEBM, VED1, VED2, VED3, VED5, VGE4, VG24, VHH4, VMB3, VMS4, VSD, VSD1, VSX, VSX1, VS3, VS4, VWA2, VW12, VX, VXG, VXM, VXU, VXW, VXW1, VXW2, VX2, VX26, VX4, WKT2, WME2, WMT, W1
			1	-	-	-	5066322	QNT4,VED7,VPM4,VPR4, VSB1
			-	-	-	1	2000029	5066322 VSDP,VXP

2

Ref. No.	Part No.	Description	Reqd. QTY				Serial No.	Parts catalogue code
			(1)	(2)	(3)	(4)		
(7)	19612-ZH8-812	PLATE, SIDE (OIL ALERT)	1	(1)	-	-	5066323 5372718	HG12, HX, HX2, HX26, HX4, LJC7, LX, LX2, LX26, LX4, L1, PX, PX2, QBT2, QBT6, QGR2, QMC8, QMH, QMX2, QNT, QNT4, QWM2, QWX2, QX, QXB1, QXC, QXC6, QXC9, QXF2, QXQ, QX2, QX26, QX4, Q1, RX, RX4, SG24, SJC1, SJC5, SMC7, SMJ, SMJ1, SMW2, SNX, SSSX2, SX, SXB, SX4, S1, TX, TXC9, TX2, TX26, TX4, UX, VA2, VEBM, VED1, VED2, VED3, VED5, VED7, VGE4, VG24, VHH4, VMB3, VMS4, VPM4, VPR4, VSB1, VSD, VSD1, VSX, VSX1, VS3, VS4, VWA2, VW12, VX, VXG, VXM, VXU, VXW2, VX2, VX26, VX4, WKT2, WME2, WMT, W1
			1	-	-	-	-----	QS2, QWA4, VEN2, VPM5, VSG
			1	-	-	-	-----	5372718 QXM1, VTD, VTD1, VTX, VTX1
			-	-	-	1	-----	5066323 VSDP, VXP
	19612-ZH8-820	PLATE, SIDE (LAMP)	1	(1)	-	-	-----	H1, LSS, NSJ, RHA, SW2, U1
			1	(1)	-	-	-----	4795906 LAX, LAX2, QAX, QXS, T1, V1, W1
			1	(1)	-	-	-----	4795906 5066322 EMA, EMA2, L1, QAX2, QMD6, QXS2, Q1, R1, SMC9, S1, VXD, VXD1
			1	-	-	-	-----	5066322 LW2, QMC6, QP, RHA2, RMG2, RSK, SDS
	19612-ZH8-821	1	(1)	-	-	-----	5066323 LSS, LW2, L1, NSJ, QMC6, QP, RHA2, RMG2, RSK, R1, SDS
			1	(1)	-	-	-----	5066323 5372718 EMA, EMA2, QAX2, QMD6, QXS2, Q1, SMC9, S1, VXD, VXD1
			1	-	-	-	-----	LHW
	19612-ZH8-830	PLATE, SIDE (ALERT & LAMP) ..	1	(1)	-	-	-----	4795905 EMA, EMA2, LAX, LAX2, L1, QAX, QAX2, QMD6, QXS, QXS2, Q1, R1, SMC9, S1, T1, VXD, VXD1, V1, W1
			-	(1)	-	-	-----	H1, U1
	19612-ZK8-V00	PLATE, SIDE	1	-	-	-	-----	AR, ARC6, KR
9	19612-ZH8-840	PLATE, SIDE (STARTER MOTOR) -	1	-	-	-	-----	HXE, HXE2, HXE8, LSS1, QHE, QKA4, QNZ, QSC2, QXE, QXE2, QXE4, QXE6, QXE8, QXW, QXW2, REX4, RXE, RXE2, RXE4, SEE, SKM, SNX1, ST, STM, SWG4, SXE, SXE4, VSW, VXE, VXE4, VXE6, VXE7
			-	(1)	-	-	-----	
10	19613-ZE1-000	CLAMPER, CORD	1	(1)	-	1	-----	4368640 EMA, HG1, HX, HX26, HX4, LAX, LX, LX26, LX4, L1, PX, QAX, QBT2, QBT6, QBU2, QMC8, QMD6, QMH, QNT, QNT2, QX, QXB, QXB1, QXC, QXC6, QXF, QXS, QX26, QX4, Q1, RX, RX4, SAD2, SG24, SJC1, SMC7, SMC9, SMJ, SMJ1, SSSX2, SWX, SX, SXB, SX4, S1, TX, TX26, TX4, T1, UX, VA, VEBM, VED1, VED5, VG24, VHH4, VMB3, VMS4, VSD, VSDP, VSD1, VSX, VSX1, VWA, VX, VXD, VXD1, VXG, VXP, VXU, VXW, VXW1, VX26, VX4, V1, WME2, W1
			1	(1)	-	-	-----	ETX, H1, RHA, R1, U1
			1	-	-	-	-----	4367320 EMA2, HG12, HXQ, HX2, LAX2, LX2, PX2, QAX2, QGR2, QMX2, QXC9, QXF2, QXQ, QXS2, QX2, SMW2, TXC9, TX2, VA2, VEB2, VWA2, VW12, VXW2, VX2, WKT2
			1	-	-	-	-----	4795905 WMT
			1	-	-	-	-----	5313298 NSJ, RHA2, SNX, VED2, VED3, VED7, VGE4, VPM4, VPR4, VSB1, VS3, VS4, VTX, VTX1
	19613-ZE1-010	CLAMP, CORD	1	-	-	-	-----	5313299 5388112 NSJ, RHA2, SNX, VED2, VED3, VED7, VGE4, VPM4, VPR4, VSB1, VS3, VS4, VTX, VTX1
			1	-	-	-	-----	VEN2, VES, VPM7, VPR7, VSG
	19613-ZE1-020	1	-	-	-	-----	5388113 NSJ, RHA2, SNX, VED2, VED3, VED7, VGE4, VPM4, VPR4, VSB1, VS3, VS4, VTX, VTX1
			1	(1)	-	1	-----	4368641 EMA, HG1, HX, HX26, HX4, LAX, LX, LX26, LX4, L1, PX, QAX, QBT2, QBT6, QBU2, QMC8, QMD6, QMH, QNT, QNT2, QX, QXB, QXB1, QXC, QXC6, QXF, QXS, QX26, QX4, Q1, RX, RX4, SAD2, SG24, SJC1, SMC7, SMC9, SMJ, SMJ1, SSSX2, SWX, SX, SXB, SX4, S1, TX, TX26, TX4, T1, UX, VA, VEBM, VED1, VED5, VG24, VHH4, VMB3, VMS4, VSD, VSDP, VSD1, VSX, VSX1, VWA, VX, VXD, VXD1, VXG, VXP, VXU, VXW, VXW1, VX26, VX4, V1, WME2, W1
			1	-	1	1	-----	HXU, LJC7, LXU, PXU, QCL, QGR9, QI2, QNT4, QSC9, QS2, QWA4, QWM2, QWX2, QWX3, QXM1, QXU, QX22, QX7, RXU, SJC5, SMX4, SM12, SM14, STM, SWX2, SWX4, SXP1, SXS4, SXU, SX7, TCS2, TXU, UXU, VED6, VHA7, VIH1, VMS7, VMT, VPM5, VSD7, VSX3, VS17, VTD, VTD1, VTU1, VXM, VXU1, WKD6, WKT4, WKT6
			1	-	-	-	-----	4367321 EMA2, HG12, HXQ, HX2, LAX2, LX2, PX2, QAX2, QGR2, QMX2, QXC9, QXF2, QXQ, QXS2, QX2, SMW2, TXC9, TX2, VA2, VEB2, VWA2, VW12, VXW2, VX2, WKT2



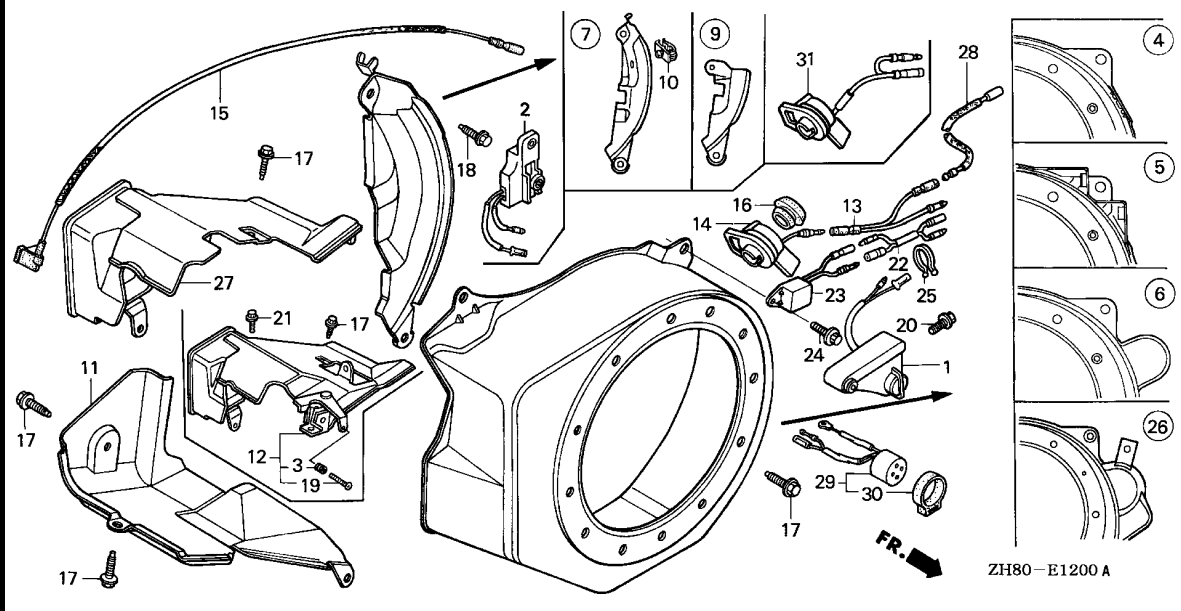

ZH80-E1200 A

Ref. No.	Part No.	Description	Reqd. QTY				Serial No.	Parts catalogue code
			(1)	(2)	(3)	(4)		
			GX160K1					
11	19630-ZH8-000	SHROUD COMP.	1	-	-	-	-----	BL,DS,DSP,EN,ET,ETX,HG1,HG12,HH,HHQ4,HH26,HX,HXE,HXE2,HXE8,HXQ HXU,HX2,HX26,HX4,KTA,LAX,LAX2,LD,LDB1,LDB3,LDM,LD4,LH,LHB3 LHQ4,LHW,LJ,LJC7,LJD,LJG,LJS,LMT,LSJ,LSJ4,LSS,LSS1,LSS4,LTA LTK,LVL,LW2,LX,LXU,LX2,LX26,LX4,NJ,NJG,NSJ,NW,PH,PHM,PHU,PM PM2,PX,PXU,PX2,QA,QAB1,QAB3,QAX,QAX2,QA2,QA26,QBC2,QBT2,QBT6 QBU2,QCB2,QCL,QD,QE,QFE4,QGR2,QGR9,QH,QHE,QHP1,QHQ4,QH26,QI2 QKA4,QM,QMC6,QMC8,QMD6,QME4,QMH,QMX2,QMZ2,QNT,QNT2,QNT4,QNZ,QP QPU,QSC2,QSC9,QS2,QT,QVL,QWA4,QWM2,QWX2,QWX3,QX,QXB,QXB1,QXC QXC6,QXC9,QXE,QXE2,QXE4,QXE6,QXE8,QXF,QXF2,QXM1,QXQ,QXS,QXS2 QXU,QXW,QXW2,QX2,QX22,QX26,QX4,QX7,QZ,RAC,RD,RD4,REX4,RFR,RFR2 RH,RHA,RHA2,RHQ4,RH2,RH26,RMB4,RMD,RMG2,RNG,RSK,RSS1,RTB2,RX RXE,RXE2,RXE4,RXU,RX4,SAC,SAD2,SCJ,SD,SDB1,SDB3,SDN,SDS,SDS2 SDS3,SD16,SD4,SE,SEE,SG24,SH,SHM,SHQ4,SHRY,SHR4,SJ,SJC,SJC1 SJC5,SJG,SMB4,SMC7,SMC9,SMJ,SMJ1,SMW2,SMX4,SM11,SM12,SM14,SNX SNX1,SSK1,SSK2,SSX2,ST,STA,STM,STP,STQ,SWG4,SWX,SWX2,SWX4,SW2 SX,SXB,SXE,SXE4,SXS4,SXU,SX4,SX7,S1CY,TCS2,TH,THU,TX,TXC9,TXU TX2,TX26,TX4,UH,UX,UXU,VA,VA2,VEBM,VEB2,VED,VED1,VED5,VED6 VGE4,VG24,VH,VHA7,VHH4,VHQ4,VMB3,VMS4,VMS7,VPM4,VPM5,VPM7,VPR4 VPR7,VS,VSD,VSD1,VSD7,VSX,VSX1,VSX3,VS1,VS17,VTD,VTD1,VTU1,VVA VVA2,VW12,VX,VXD,VXD1,VXE,VXE4,VXE6,VXE7,VXG,VXM,VXU,VXU1,VXW VXW1,VXW2,VX2,VX26,VX4,WDA6,WJP,WKD6,WKT2,WKT4,WKT6,WMB0,WME2 WME4,WMT
	19630-ZB2-000	SHROUD COMP., LOWER	1	-	-	-	-----	EMA,EMA2,SKM,VED2,VED3,VED7,VEN2,VES,VMT,VSU1,VSG,VSW,VS3,VS4 VTE2,VTX,VTX1
12	19640-ZB2-010	SHROUD ASSY., UPPER	1	-	-	-	-----	EMA,VED2,VED3,VED7,VEN2,VES,VMT,VSU1,VSG,VS3,VTE2,VTX
			1	-	-	-	-----	5048024 EMA2,VSW,VS4

Ref. No.	Part No.	Description	Reqd. QTY				Serial No.	Parts catalogue code
			GX160K1					
			(1)	(2)	(3)	(4)		
12)	19640-ZH8-R60	SHROUD ASSY., UPPER	1	-	-	-	VTX1	
			1	-	-	-	EMA2,VSW,VS4	
13	32197-ZH8-003	SUB HARNESS	1	-	-	1	5048025	-----
							HXU,HX26,HX4,LAX,LSS4,LXU,LX26,LX4,PXU,QA,QBT6,QBU2,QMC8,QMD6	
							QMH,QNT2,QXB,QXB1,QXC6,QXU,QX26,QX4,RXU,RX4,SAD2,SMC7,SMC9,SNX	
							SXB,SXU,SX4,TXU,TX26,TX4,UXU,VED2,VED3,VED7,VEN2,VES,VGE4,VHH4	
							VMB3,VMS4,VPM4,VPM7,VPR4,VPR7,VSDP,VSX1,VTX,VTX1,VXG,VXP,VXU	
							VXU1,VX26,VX4	
			1	-	-	-	2468253	-----
			1	-	-	-	ETX,LX,PX,QNT,QX,QXE,RX,SWX,SX,UX,VA,VEBM,VED1,VSD,VSD1,VSX	
			1	-	-	-	HXQ,HX2,LX2,PX2,QGR2,QXC9,QXF2,QXS2,QX2,TX2,VXW2,VX2	
			1	-	-	-	4367320	EMA2,HG12,LAX2,QAX2,QMX2,QXQ,SMW2,TXC9,VA2,VEB2,VWA2,VW12,WKT2
			1	-	-	-	4368640	EMA,QAX,QBT2,SG24,SJC1,SSX2,VED5,VG24,VWA,VXD,VXD1,VXW1,WME2
			1	-	-	-	2468253	4368640
			-	1	-	-	2468253	HG1,HX,QXC,QXF,QXS,SMJ,SMJ1,TX,VX,VXW
14	36100-ZE1-015	SWITCH ASSY., ENGINE STOP ...	1	-	1	-	-----	
							AR,ARC6,BL,DS,DSP,EN,HH,HH26,KR,KTA,LD,LDB1,LDB3,LDM,LH,LHB3	
							LHW,LJ,LJD,LJG,LMT,LSJ,LSS,LTA,LTK,LVL,LW2,NJ,NJG,NSJ,NW,PH	
							PHM,PHU,PM,PM2,QA,QAB1,QAB3,QA2,QA26,QCB2,QD,QH,QHP1,QH26,QIH1	
							QM,QM22,QP,QT,QVL,QZ,RAC,RD,RFR,RFR2,RH,RHA,RHA2,RH2,RH26,RMD	
							RMG2,RNG,RSS1,RTB2,SAC,SD,SDB1,SDB3,SDN,SDS2,SDS3,SD16,SH,SHM	
							SJ,SJC,SJG,SM11,SSK1,SSK2,STA,STP,STQ,TH,THU,UH,UIH,VED,VH,VS	
							VS1,WDA6,WIH1,WJP	
			1	-	-	1	4368640	EMA,EMA2,HG12,HXQ,HX2,HX26,LAX,LAX2,LX2,LX26,PX2,QAX,QAX2,QBT2
							QBT6,QBU2,QGR2,QMH,QMX2,QNT2,QXB,QXB1,QXC6,QXC9,QXF2,QXQ,QXS2	
							QX2,QX26,SAD2,SJC1,SMW2,SSX2,SW2,SXB,TXC9,TX2,TX26,VA2,VEB2	
							VED5,VSX1,VWA,VWA2,VW12,VXD,VXD1,VXP,VXU,VXW1,VXW2,VX2,VX26	
							WKT2,WME2,WMT	
			1	-	-	-	2468253	-----
			1	-	-	-	3261481	QE,RSK,SDS,SE,VXG
			1	-	-	-	2468253	2744590
			1	-	-	-	2468253	3261481
			1	-	-	-	2468253	4368640
							HG1,HX,LX,PX,QXC,QXF,QXS,RX,SMJ,SMJ1,SWX,SX,TX,UX,VA,VEBM,VED1	
							VSX,VX,VXW	
			-	(1)	-	-		
	36100-ZH7-003	1	(1)	-	1	4368641	-----
							EMA,EMA2,HG1,HG12,HX,HXQ,HX2,HX26,LAX,LAX2,LX,LX2,LX26,L1,PX	
							PX2,QAX,QAX2,QBT2,QBT6,QBU2,QGR2,QMH,QMX2,QNT2,QX,QXB,QXB1,QXC	
							QXC6,QXC9,QXF,QXF2,QXQ,QXS,QXS2,QX2,QX26,Q1,RX,SAD2,SJC1,SMJ	
							SMJ1,SMW2,SSX2,SWX,SX,SXB,S1,TX,TXC9,TX2,TX26,T1,UX,VA,VA2	
							VEBM,VEB2,VED1,VED5,VSX,VSX1,VWA,VWA2,VW12,VX,VXD,VXD1,VXP,VXU	
							VXW,VXW1,VXW2,VX2,VX26,V1,WKT2,WME2,WMT,W1	
			1	-	1	1	-----	
							HXU,LJC7,LXU,PXU,QCL,QGR9,QI2,QS2,QWM2,QWX3,QXM1,QXU,QX22	
							RXU,SJC5,SM12,STM,SWX2,SXP1,SXU,TCS2,TXU,UXU,VED6,VIH1,VMT	
							VSX3,VTD,VTD1,VTU1,VXM,VXU1,WKD6,WKT6	
36100-ZH8-W41		1	-	-	1	4368640	-----
							HX4,LX4,QMC8,QMD6,QX4,RX4,SG24,SMC7,SMC9,SX4,TX4,VG24,VHH4	
							VMB3,VMS4,VSDP,VX4	
			1	-	-	-	-----	
							HHQ4,LD4,LHQ4,LSJ4,LSS4,QFE4,QHQ4,QMC6,QME4,RD4,RHQ4,RMB4,SD4	
							SHQ4,SHRY,SHR4,SMB4,S1CY,VGE4,VHQ4,WMB0,WME4	
			1	-	-	-	3261482	-----
			1	-	-	-	3261482	4368640
							QE,RSK,SDS,SE	
							QNT,VSD,VXG	
36100-ZH7-W41		1	-	-	1	4368641	-----
							HX4,LX4,QMC8,QMD6,QNT,QX4,RX4,SG24,SMC7,SMC9,SX4,TX4,VG24,VHH4	
							VMB3,VMS4,VSD,VSDP,VXG,VX4	
							QNT4,QWA4,QX7,SMX4,SM14,SWX4,SXS4,SX7,VHA7,VMS7,VSD7,WKT4	
36100-ZH8-W81	SWITCH ASSY., ENGINE STOP		1	-	-	-	-----	
	(SDMO)		1	-	-	-	2744591	4368640
							VSD1	
36100-ZH8-W82		1	-	-	-	-----	
							VS17	
			1	-	-	-	4368641	-----
							VSD1	
35120-Z0D-V81	SWITCH ASSY., ENGINE STOP ...		1	-	-	-	-----	
							QBC2	



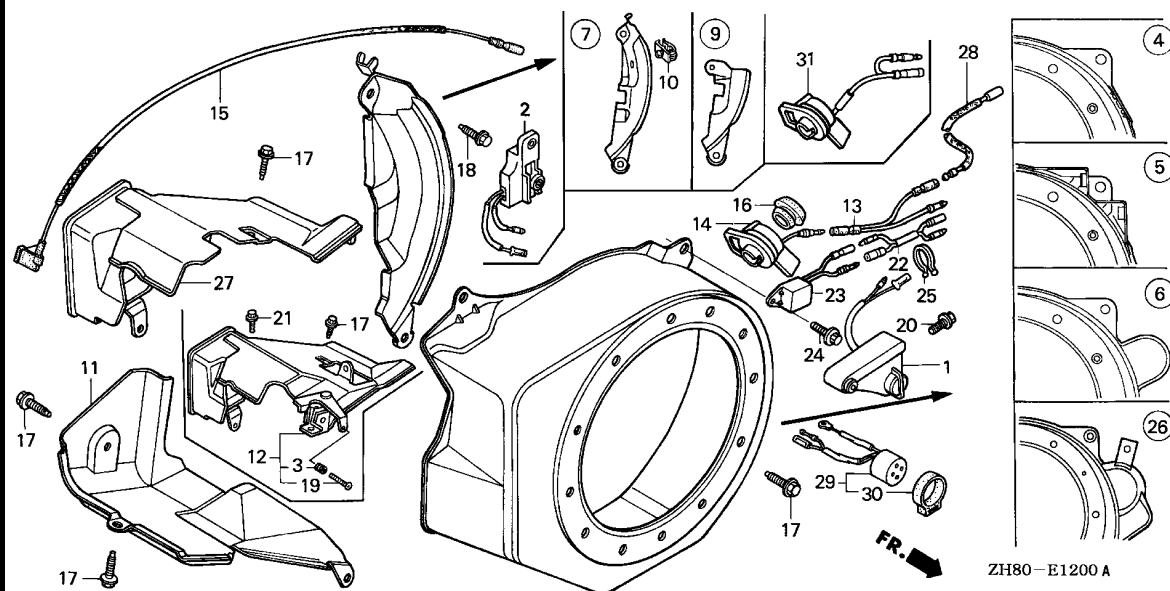

ZH80-E1200 A

Ref. No.	Part No.	Description	Reqd. QTY				Serial No.	Parts catalogue code
			(1)	(2)	(3)	(4)		
15	36101-ZB2-010	CORD, STOP SWITCH (395MM) ...	1	-	-	-	HXE, HXE2, HXE8, QHE, QKA4, QXE, QXE4, QXE6, QXE8, QXW, QXW2, REX4, RXE, RXE2, RXE4, SEE, SWG4, SXE, SXE4, VED2, VED3, VEN2, VES, VSB1, VSG, VSW, VS3, VS4, VTE2, VTX, VTX1, VXE, VXE4, VXE6, VXE7	
	36101-ZE1-010	CORD, STOP SWITCH (370MM) ...	1	(1)	-	-	ARC6, BL, DS, DSP, EMA, EN, ET, ETX, HG1, HH, HHQ4, HH26, HX, HXU, HX26, HX4, KR, KTA, LAX, LD, LDB1, LDB3, LDM, LD4, LH, LHB3, LHQ4, LHW, LJ, LJC7, LJD, LJG, LJS, LMT, LSJ, LSJ4, LSS, LSS1, LSS4, LTA, LTK, LVL, LW2, LX, LXU, LX26, LX4, NJ, NJC1, NJG, NSJ, NW, PH, PHM, PHU, PM, PM2, PX, PXU, QA, QAB1, QAB3, QAX, QA26, QBC2, QBT6, QBU2, QD, QE, QFE4, QH, QHP1, QHQ4, QH26, QI2, QM, QMC6, QMC8, QMD6, QME4, QMH, QNT, QNT2, QNT4, QNZ, QP, QPU, QS2, QT, QVL, QWA4, QX, QXB, QXB1, QXC, QXC6, QXF, QXM1, QXS, QXU, QX22, QX26, QX4, QX7, QZ, RAC, RD, RD4, RFR, RH, RHA, RHQ4, RH26, RMB4, RMD, RNG, RSK, RSS1, RX, RXU, RX4, SAC, SAD2, SCJ, SD, SDB1, SDB3, SDN, SDS, SDS2, SDS3, SD16, SD4, SE, SH, SHM, SHQ4, SHRY, SHR4, SJ, SJC, SJC1, SJC5, SJG, SKM, SMB4, SMC7, SMC9, SMJ, SMJ1, SMX4, SM11, SM14, SNX, SNX1, SSK1, ST, STA, STM, STP, STQ, SWX, SWX2, SWX4, SW2, SX, SXB, SXS4, SXU, SX4, SX7, S1CY, TH, THU, TX, TXU, TX26, TX4, UH, UX, UXU, VA, VEBM, VED, VED1, VED5, VED6, VGE4, VH, VHA7, VHH4, VHQ4, VMB3, VMS4, VMS7, VMT, VPM4, VPM5, VPM7, VPR4, VPR7, VS, VSD, VSD1, VSD7, VSX, VSX1, VSX3, VS1, VS17, VTD, VTD1, VTU1, VVA, VX, VXD, VXD1, VXG, VXM, VXU, VXU1, VWX, VWX1, VX26, VX4, WDA6, WJP, WKD6, WKT4, WMBO, WME4, WMT	
16	81329-567-020	GROMMET, DRAIN HOLE	1	-	-	-	ET, ETX, LJS, QPU, QSC9, SCJ, SNX, VED2, VED3, VED7, VEN2, VES, VGE4, VPM4, VPM7, VPR4, VPR7, VSB1, VSG, VS3, VS4, VTE2, VTX, VTX1	
17	90016-ZE1-000	BOLT, FLANGE, 6X13(CT200) ...	6	(1)	-	-	2708336 HG1, HX, QA, QX, QXC, QXE, QXF, QXS, RFR, RH, TX, VVA, VX, VXW	

Ref. No.	Part No.	Description	Reqd. QTY				Serial No.	Parts catalogue code
			(1)	(2)	(3)	(4)		
17)	90013-883-000	BOLT, FLANGE, 6X12(CT200) ...	4	-	-	-	AR,ARC6,KR,NJC1	
			6	-	-	-	BL,DS,DSP,EN,ET,ETX,HG12,HH,HHQ4,HH26,HXE,HXE2,HXE8,HXQ,HXU HX2,HX26,HX4,KTA,LAX,LAX2,LD,LDB1,LDB3,LDM,LD4,LH,LHB3,LHQ4 LHW,LJ,LJC7,LJD,LJG,LJS,LMT,LSJ,LSJ4,LSS,LSS1,LSS4,LTA,LTk,LVL LW2,LX,LXU,LX2,LX26,LX4,NJ,NJG,NSJ,NW,PH,PHM,PHU,PM,PM2,PX,PXU PX2,QAB1,QAB3,QAX,QAX2,QA2,QA26,QBC2,QBT2,QBT6,QBU2,QCB2,QCL QD,QE,QFE4,QGR2,QGR9,QH,QHE,QHP1,QHQ4,QH26,QI2,QKA4,QM,QMC6 QMC8,QMD6,QME4,QMH,QMX2,QMZ2,QNT,QNT2,QNT4,QNZ,QP,QPU,QSC2 QSC9,QS2,QT,QVL,QWA4,QWM2,QWX2,QWX3,QXB,QXB1,QXC6,QXC9,QXE2 QXE4,QXE6,QXE8,QXF2,QXM1,QXQ,QXS2,QXU,QXW,QXW2,QX2,QX22,QX26 QX4,QX7,QZ,RAC,RD,RD4,REX4,RFR2,RHA,RHA2,RHQ4,RH2,RH26,RMB4 RMD,RMG2,RNG,RSK,RSS1,RTB2,RX,RXE,RXE2,RXE4,RXU,RX4,SAC,SAD2 SCJ,SD,SDB1,SDB3,SDN,SDS,SDS2,SDS3,SD16,SD4,SE,SEE,SG24,SH,SHM SHQ4,SHRY,SHR4,SJ,SJC,SJC1,SJC5,SJG,SMB4,SMC7,SMC9,SMJ,SMJ1 SMW2,SMX4,SM11,SM12,SM14,SNX,SNX1,SSK1,SSK2,SSX2,ST,STA,STM STP,STQ,SWG4,SWX,SWX2,SWX4,SW2,SX,SBX,SXE,SXE4,SXS4,SXU,SX4 SX7,S1CY,TCS2,TH,THU,TXC9,TXU,TX2,TX26,TX4,UH,UX,UXU,VA,VA2 VEBM,VEB2,VED,VED1,VED5,VED6,VGE4,VG24,VH,VHA7,VHH4,VHQ4,VMB3 VMS4,VMS7,VPM4,VPM5,VPM7,VPR4,VPR7,VS,VSD,VSD1,VSD7,VSX,VSX1 VSX3,VS1,VS17,VTD,VTD1,VTU1,VWA2,VW12,VXD,VXD1,VXE,VXE4,VXE6 VXE7,VXG,VXM,VXU,VXU1,VXW1,VXW2,VX2,VX26,VX4,WDA6,WJP,WKD6 WKT2,WKT4,WKT6,WMB0,WME2,WME4,WMT	
			6	-	-	2708337	HG1,HX,QA,QX,QXC,QXE,QXF,QXS,RFR,RH,TX,VWA,VX,VXW	
			8	-	-	-	EMA,EMA2,SKM,VED2,VED3,VED7,VEN2,VES,VMT,VSB1,VSG,VSW,VS3,VS4 VTE2,VTX,VTX1	
18	90022-888-010	BOLT, FLANGE, 6X20(CT200) ...	-	6	6	6	AR,ARC6,BL,DS,DSP,EMA,EMA2,EN,ET,ETX,HG1,HG12,HH,HHQ4,HH26,HX HXQ,HXU,HX2,HX26,HX4,KR,KTA,LAX,LAX2,LD,LDB1,LDB3,LDM,LD4,LH LHB3,LHQ4,LHW,LJ,LJC7,LJD,LJG,LJS,LMT,LSJ,LSJ4,LSS,LSS4,LTA LTK,LVL,LW2,LX,LXU,LX2,LX26,LX4,NJ,NJC1,NJG,NSJ,NW,PH,PHM,PHU PM,PM2,PX,PXU,PX2,QA,QAB1,QAB3,QAX,QAX2,QA2,QA26,QBC2,QBT2 QBT6,QBU2,QCB2,QCL,QD,QE,QFE4,QGR2,QGR9,QH,QHP1,QHQ4,QH26,QI2 QM,QMC6,QMC8,QMD6,QME4,QMH,QMX2,QMZ2,QNT,QNT2,QNT4,QP,QPU,QSC9 QS2,QT,QVL,QWA4,QWM2,QWX2,QWX3,QX,QXB,QXB1,QXC,QXC6,QXC9,QXE2 QXF,QXF2,QXM1,QXQ,QXS,QXS2,QXU,QX2,QX22,QX26,QX4,QX7,QZ,RAC,RD RD4,RFR,RFR2,RH,RHA,RHA2,RHQ4,RH2,RH26,RMB4,RMD,RMG2,RNG,RSK RSS1,RTB2,RX,RXU,RX4,SAC,SAD2,SCJ,SD,SDB1,SDB3,SDN,SDS,SDS2 SDS3,SD16,SD4,SE,SG24,SH,SHM,SHQ4,SHRY,SHR4,SJ,SJC,SJC1,SJC5 SJG,SKM,SMB4,SMC7,SMC9,SMJ,SMJ1,SMW2,SMX4,SM11,SM12,SM14,SNX SSK1,SSK2,SSX2,STA,STM,STP,STQ,SWX,SWX2,SWX4,SW2,SX,SBX,SXS4 SXU,SX4,SX7,S1CY,TCS2,TH,THU,TX,TXC9,TXU,TX2,TX26,TX4,UH,UX UXU,VA,VA2,VEBM,VEB2,VED,VED1,VED2,VED3,VED5,VED6,VED7,VEN2 VES,VGE4,VG24,VH,VHA7,VHH4,VHQ4,VMB3,VMS4,VMS7,VMT,VPM4,VPM5 VPM7,VPR4,VPR7,VS,VSB1,VSD,VSD1,VSD7,VSG,VSX,VSX1,VSX3,VS1 VS17,VS3,VS4,VTD,VTD1,VTE2,VTU1,VTX,VTX1,VWA,VWA2,VW12,VX,VXD VXD1,VXG,VXM,VXU,VXU1,VXW,VXW1,VXW2,VX2,VX26,VX4,WDA6,WJP,WKD6 WKT2,WKT4,WKT6,WMB0,WME2,WME4,WMT	
	90121-952-000	BOLT, FLANGE, 6X25	-	(1)	1	1	QXE,REX4,RXE2,RXE4,SNX1,VSW,VXE7	
19	93500-05035-0A	SCREW, PAN, 5X35	1	-	-	-	EMA,VED2,VED3,VED7,VEN2,VES,VMT,VSB1,VSG,VS3,VTE2,VTX,VTX1	
			1	-	-	-	EMA2,VSW,VS4	
	93500-05040-0G	SCREW, PAN, 5X40	1	-	-	5048025	EMA2,VSW,VS4	
20	95701-06008-00	BOLT, FLANGE, 6X8	2	-	-	-	2468252 HG1,HX,LX,PX,QNT,QX,QXC,QXF,QXS,RX,SMJ,SMJ1,SWX,SX,TX,UX,VA VEBM,VED1,VSD,VSD1,VSX,VX,VXW	
			-	(2)	-	-	2468252	
21	95701-06010-00	BOLT, FLANGE, 6X10	1	-	-	-	3223676 VED2,VED3,VS3,VS4	



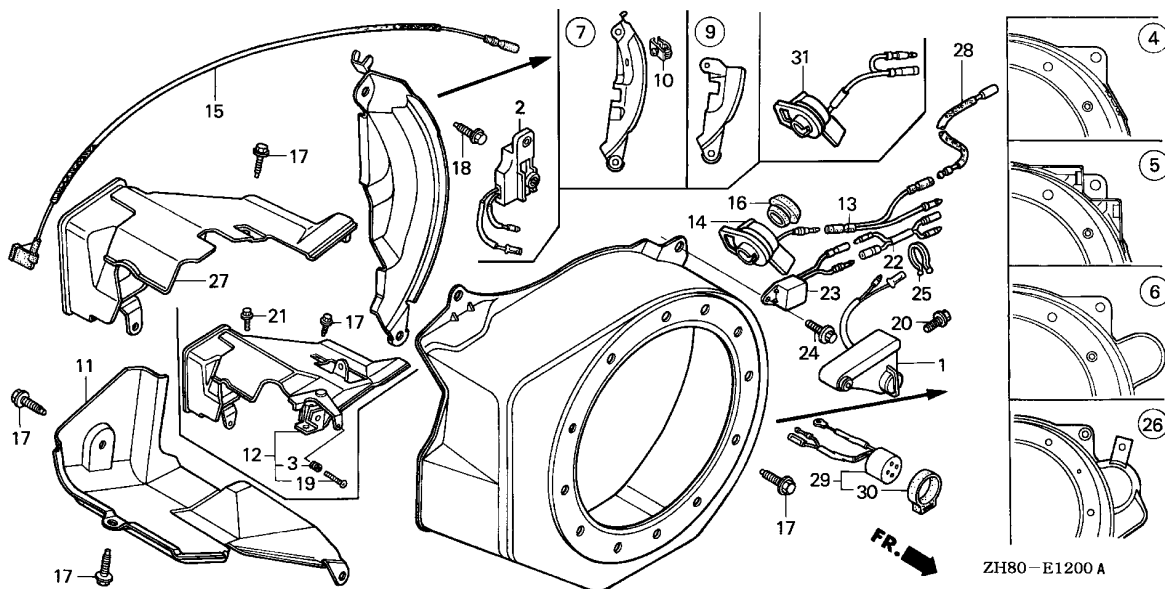

ZH80-E1200 A

Ref. No.	Part No.	Description	Reqd. QTY				Serial No.	Parts catalogue code
			(1)	(2)	(3)	(4)		
21)	95701-06008-00	BOLT, FLANGE, 6X8	1	-	-	-	-----	EMA,EMA2,VED7,VEN2,VES,VMT,VSB1,VSG,VSW,VTE2,VTX,VTX1 VED2,VED3,VS3,VS4
			1	-	-	-	3223677	-----
			1	-	-	-	3293355	-----
			1	(1)	-	-	5372719	-----
22	32105-ZH8-V10	CABLE, DOUBLE CONNECTOR	1	(1)	-	-	5372719	-----
23	34150-ZH7-003	ALERT UNIT, OIL	1	(1)	-	-	5372719	-----
								L1,Q1,SKM,SNX1,SWG4,S1,VSW,W1
								EMA,EMA2,HG12,HX,HX2,HX26,HX4,LJC7,LX,LX2,LX26,LX4,L1,PX,FX2 QAX2,QBT6,QGR2,QMC8,QMD6,QMH,QMX2,QNT,QNT4,QX,QXB1,QXC,QXC6 QXC9,QXF2,QXM1,QXQ,QXS2,QX2,QX26,QX4,Q1,RX,RX4,SJC1,SJC5,SKM SMC7,SMC9,SMJ,SMJ1,SMW2,SNX,SNX1,SWG4,SX,SXB,SX4,S1,TX,TXC9 TX2,TX26,TX4,UX,VA2,VEBM,VED1,VED2,VED3,VED5,VGE4,VHH4,VMB3 VMS4,VPM4,VPR4,VSB1,VSD,VSD1,VSW,VSX,VSX1,VS3,VS4,VTD,VTD1,VTX VTX1,VWA2,VW12,VX,VXD,VXD1,VXG,VXM,VXU,VXW2,VX2,VX26,VX4,WKT2 WMT,W1
			1	-	1	1	-----	HXU,LXU,PXU,QS2,QWA4,QXU,QX7,RXU,SMX4,SM14,STM,SWX2,SWX4,SXP1 SXS4,SXU,SX7,TXU,UXU,VED6,VEN2,VES,VHA7,VIH1,VMS7,VMT,VPM5 VPM7,VPR7,VSD7,VSG,VSX3,VS17,VTU1,VXU1,WKD6,WKT4,WKT6
			-	-	-	1	2000069	-----
24	95701-06008-00	BOLT, FLANGE, 6X8	1	(1)	-	-	5372719	-----
								VSDP,VXP
								EMA,EMA2,HG12,HX,HX2,HX26,HX4,LJC7,LX,LX2,LX26,LX4,L1,PX,FX2 QAX2,QBT6,QGR2,QMC8,QMD6,QMH,QMX2,QNT,QNT4,QX,QXB1,QXC,QXC6 QXC9,QXF2,QXQ,QXS2,QX2,QX26,QX4,Q1,RX,RX4,SJC1,SJC5,SMC7,SMC9 SMJ,SMJ1,SMW2,SNX,SX,SXB,SX4,S1,TX,TXC9,TX2,TX4,UX,VA2,VEBM VED1,VED2,VED3,VED5,VGE4,VHH4,VMB3,VMS4,VPM4,VPR4,VSB1,VSD VSD1,VSX,VSX1,VS3,VS4,VTD,VTD1,VTX,VTX1,VWA2,VW12,VX,VXD,VXD1 VXG,VXM,VXU,VXW2,VX2,VX26,VX4,WKT2,WMT,W1
			1	-	1	1	-----	HXU,LXU,PXU,QS2,QWA4,QXU,QX7,RXU,SMX4,SM14,STM,SWX2,SWX4,SXP1 SXS4,SXU,SX7,TXU,UXU,VED6,VEN2,VES,VHA7,VIH1,VMS7,VMT,VPM5 VPM7,VPR7,VSD7,VSG,VSX3,VS17,VTU1,VXU1,WKD6,WKT4,WKT6
			-	-	-	1	2000069	-----
			1	-	-	-	5372719	-----
								VSDP,VXP
								SNX1,SWG4,VSW
25	90630-751-000	CLIP, PURSE LOCK	1	-	-	-	-----	

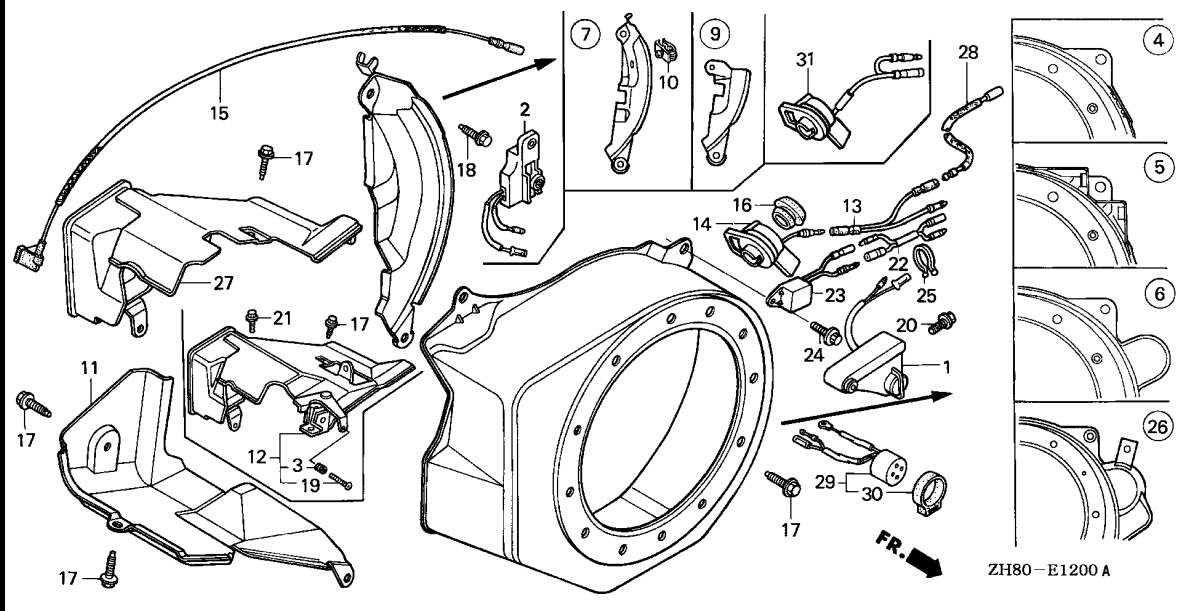

ZH80-E1200 A

Ref. No.	Part No.	Description	Reqd. QTY				Serial No.	Parts catalogue code
			(1)	(2)	(3)	(4)		
			GX160K1					
26	19610-ZE1-830ZA	COVER COMP., FAN (STARTER MOTOR)	1	-	-	-	-	QXE2
		NH1.....BLACK	1	-	-	-	-	HXE,H1,QXW2,Q1,REX4,R1,SEE,S1,T1,U1,VXE,VXE6,V1,W1
	19610-ZE1-830ZB	*R8*.....BRIGHT RED	1	(1)	-	-	8373305	HXE2,HXE8,L1,QHE,QKA4,QSC2,QXE,QXE2,QXE4,QXE6,QXE8,QXW,RXE2,RXE4,SXE,SXE4,VXE4,VXE7
	19610-ZE1-830ZG	*R280*.....POWER RED	1	(1)	-	-	8373306	HXE2,HXE8,L1,QHE,QKA4,QSC2,QXE,QXE2,QXE4,QXE6,QXE8,QXW,RXE2,RXE4,SXE,SXE4,VXE4,VXE7
27	19640-ZH8-V11	SHROUD ASSY., UPPER (KOMATSU)	1	-	-	-	-	SKM
28	35310-887-940	CORD A, ENGINE STOP	1	-	-	-	-	LJS
29	38400-ZE8-003	BUZZER ASSY.	1	-	-	-	-	SKM
30	38402-GC1-000	SUSPENSION, AUDIBLE PILOT	1	-	-	-	-	SKM
31	36100-ZF6-P81	SWITCH ASSY., ENGINE STOP	1	-	-	-	-	VPM5



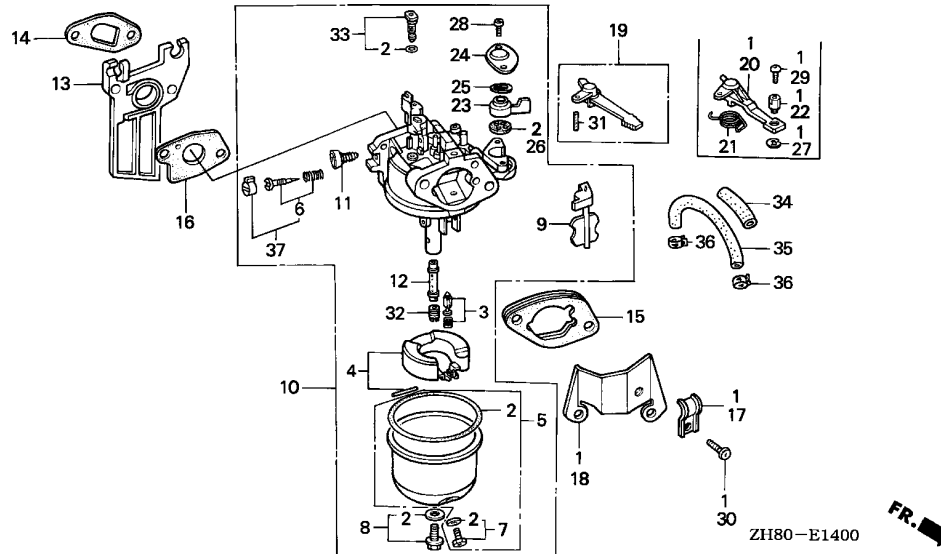

Ref. No.	L.O.N.	(Relative ref. Number) Description	F.R.T.
1	8101C4	CHOKE KIT, REMOTE CONTROL	0.2
2	3111B1	GASKET SET, CARBURETOR	0.3
3	3111E1	VALVE SET, FLOAT AND/OR FLOAT SET	0.3
10	3111F3	CARBURETOR	0.2
13	3111C0	INSULATOR, CARBURETOR AND/OR PACKING, INSULATOR	0.2
16	3111C8	PACKING, CARBURETOR	0.2
19	8101F9	LEVER, CARBURETOR CHOKE	0.2
26	3101C5	PACKING, FUEL COCK	0.2
32	3111C3	JET, MAIN	0.3
35	3101F6	TUBE, FUEL	0.2
37	3111D7	SCREW SET, PILOT	0.2

2

Ref. No.	Part No.	Description	Reqd. QTY				Serial No.	Parts catalogue code
			(1)	(2)	(3)	(4)		
1	06164-ZE1-000	CHOKE KIT, REMOTE CONTROL ...	-	(1)	-	-		
2	16010-ZE0-025	GASKET SET	1	-	-	-	LD,LDB1,LDB3,LDM,LD4,LSJ4,LTA,LW2,PM,PM2,QD,QE,QFE4,QM,QMC6,QNZ,RD,RD4,SD,SDB1,SDB3,SDS,SD16,SD4,SE,SEE,SWX,SW2,VEBM,WMB0,WME4,WMT	
	16010-ZB1-015	-	(1)	-	-	ARC6	
3	16011-ZE0-005	VALVE SET, FLOAT	1	-	-	-	ARC6,LD,LDB1,LDB3,LDM,LD4,LSJ4,LTA,LW2,PM,PM2,QD,QE,QFE4,QM,QMC6,QNZ,RD,RD4,SD,SDB1,SDB3,SDS,SD16,SD4,SE,SEE,SWX,SW2,VEBM,WMB0,WME4,WMT	
4	16013-ZE0-005	FLOAT SET	1	-	-	-	ARC6,LD,LDB1,LDB3,LDM,LD4,LSJ4,LTA,LW2,PM,PM2,QD,QE,QFE4,QM,QMC6,QNZ,RD,RD4,SD,SDB1,SDB3,SDS,SD16,SD4,SE,SEE,SWX,SW2,VEBM,WMB0,WME4,WMT	
5	16015-ZE1-811	CHAMBER SET, FLOAT	1	(1)	-	-	ARC6,H1,LD,LDB1,LDB3,LD4,LTA,LW2,L1,PM,PM2,QD,QE,QM,QMC6,Q1,RD,RD4,R1,SD,SDB1,SDB3,SDS,SD16,SD4,SE,SEE,SWX,SW2,T1,U1,VEBM,V1,WMB0,WMT,W1	
	16015-ZE0-831	(CARBURETOR NO.)	1	(1)	-	-	BE06H B QNZ,S1	
		(CARBURETOR NO.)	1	(1)	-	-	BE06H C LD,LDB1,LDB3,LD4,LTA,LW2,PM,PM2,QD,QE,QM,QMC6,QNZ,Q1,RD,RD4,R1,SD,SDB1,SDB3,SDS,SD16,SD4,SE,SEE,SWX,SW2,S1,T1,VEBM,V1,WMB0,WMT,W1	
			1	-	-	-	LDM,LSJ4,QFE4,WME4	
6	16016-ZE0-005	SCREW SET, PILOT	1	-	-	-	ARC6,LD,LDB1,LDB3,LDM,LD4,LSJ4,LTA,LW2,PM,PM2,QD,QE,QFE4,QM,QMC6,QNZ,RD,RD4,SD,SDB1,SDB3,SDS,SD4,SE,SEE,SWX,SW2,VEBM,WMB0	
		(CARBURETOR NO.)	1	-	-	-	BE06H C SD16,WME4,WMT	
			-	(1)	-	-		

Ref. No.	Part No.	Description	Reqd. QTY				Serial No.	Parts catalogue code
			(1)	(2)	(3)	(4)		
7	16024-ZE1-811	SCREW SET, DRAIN	1	-	-	-	ARC6,LD,LDB1,LDB3,LDM,LD4,LSJ4,LTA,LW2,PM,PM2,QD,QE,QFE4,QM,QMC6,QNZ,RD,RD4,SD,SDB1,SDB3,SDS,SD16,SD4,SE,SEE,SWX,SW2,VEBM,WMB0,WME4,WMT	
8	16028-ZE0-005	SCREW SET	1	(1)	-	-	ARC6,LD,LDB1,LDB3,LDM,LD4,LSJ4,LTA,LW2,PM,PM2,QD,QE,QFE4,QM,QMC6,QNZ,RD,RD4,SD,SDB1,SDB3,SDS,SD16,SD4,SE,SEE,SWX,SW2,VEBM,WMB0,WME4,WMT	
9	16044-ZE0-005	CHOKE SET	1	(1)	-	-	WMT	
		(CARBURETOR NO.)	1	-	-	-	BE06H B LD,LDB1,LDB3,LDM,LD4,LSJ4,LTA,LW2,PM,PM2,QD,QE,QFE4,QM,QMC6,QNZ,RD,RD4,SD,SDB1,SDB3,SDS,SD16,SD4,SE,SEE,SWX,SW2,VEBM,WMB0,WME4	
	16044-ZK8-V00	///	1	(1)	-	-	BE06H B	
10	16100-ZH8-810	CARBURETOR ASSY. (BE06H A) ..	1	-	-	-	ARC6 2895090 LD,LTA,LW2,PM,PM2,QD,QE,QM,RD,SD,SDS,SE,SEE,SWX,SW2,VEBM	
	16100-ZH8-811	CARBURETOR ASSY. (BE06H B) ..	1	(1)	-	-	2895090 4012407 LD,LTA,LW2,PM,PM2,QD,QE,QM,Q1,RD,R1,SD,SDS,SE,SEE,SWX,SW2,S1,T1,VEBM,V1,W1	
		///	1	-	-	-	4012407 LDB1,LDB3,LD4,QMC6,QNZ,RD4,SDB1,SDB3,SD16,SD4,WMB0,WMT	
	16100-ZH8-812	CARBURETOR ASSY. (BE06H C) ..	1	(1)	-	-	2895091 4012408 H1,L1,U1	
		///	1	-	-	-	6276049 LDB1,LDB3,LTA,LW2,PM,QM,QNZ,Q1,R1,SWX,SW2,S1,T1,V1,W1	
		///	1	-	-	-	4927944 LDM,LSJ4,QFE4,WME4	
		///	1	-	-	-	4012408 SD16	
	16100-ZH8-W41	CARBURETOR ASSY. (BE66D B) ..	1	-	-	-	4012408 LD,LD4,PM2,QD,QE,QMC6,RD,RD4,SD,SDB1,SDB3,SDS,SD4,SE,SEE,VEBM,WMB0,WMT	
	16100-ZH8-W71	CARBURETOR ASSY. (BE66E B) ..	1	-	-	-	6276050 QE,QFE4,SE,VEBM	
		///	1	-	-	-	4927945 SD16	
		///	1	-	-	-	6276050 LD,LDM,LD4,LSJ4,PM2,QD,QMC6,RD,RD4,SD,SDB1,SDB3,SDS,SD4,SEE,WMB0,WME4,WMT	
	16100-ZK8-V01	CARBURETOR ASSY. (BE67B B) ..	1	-	-	-	6276049 ARC6	
	16100-ZK8-T51	CARBURETOR ASSY. (BE67C A) ..	1	-	-	-	6276050 ARC6	
11	16124-ZE0-005	SCREW, THROTTLE STOP	1	-	-	-	ARC6,LD,LDB1,LDB3,LDM,LD4,LSJ4,LTA,LW2,PM,PM2,QD,QE,QFE4,QM,QMC6,QNZ,RD,RD4,SD,SDB1,SDB3,SDS,SD16,SD4,SE,SEE,SWX,SW2,VEBM,WMB0,WME4,WMT	
12	16166-ZH8-810	NOZZLE, MAIN	1	(1)	-	-	BE06H A LD,LTA,LW2,PM,PM2,QD,QE,QM,RD,SD,SDS,SE,SEE,SWX,SW2,VEBM	
		(CARBURETOR NO.)	1	(1)	-	-	BE06H A	
	16166-ZK8-V01	///	1	-	-	-	ARC6	
	16166-ZH8-W50	///	1	-	-	-	LDB1,LDB3,LDM,LD4,LSJ4,QFE4,QMC6,QNZ,RD4,SDB1,SDB3,SD4,WMB0	
		(CARBURETOR NO.)	1	-	-	-	BE06H B LD,LTA,LW2,PM,PM2,QD,QE,QM,RD,SD,SDS,SE,SEE,SWX,SW2,VEBM	
		///	1	-	-	-	BE06H C SD16,WME4,WMT	
		///	1	(1)	-	-	BE06H B	
	16166-ZH8-W60	///	1	-	-	-	BE66E B SD16,WME4,WMT	
		(CARBURETOR NO.)	1	-	-	-	ARC6,LD,LDB1,LDB3,LDM,LD4,LSJ4,LTA,LW2,PM,PM2,QD,QE,QFE4,QM,QMC6,QNZ,RD,RD4,SD,SDB1,SDB3,SDS,SD16,SD4,SE,SEE,SWX,SW2,VEBM,WMB0,WME4,WMT	
13	16211-ZE1-000	INSULATOR, CARBURETOR	1	-	-	-	ARC6,LD,LDB1,LDB3,LDM,LD4,LSJ4,LTA,LW2,PM,PM2,QD,QE,QFE4,QM,QMC6,QNZ,RD,RD4,SD,SDB1,SDB3,SDS,SD16,SD4,SE,SEE,SWX,SW2,VEBM,WMB0,WME4,WMT	
14	16212-ZH8-800	PACKING, INSULATOR	1	1	-	-	ARC6,LD,LDB1,LDB3,LDM,LD4,LSJ4,LTA,LW2,PM,PM2,QD,QE,QFE4,QM,QMC6,QNZ,RD,RD4,SD,SDB1,SDB3,SDS,SD16,SD4,SE,SEE,SWX,SW2,VEBM,WMB0,WME4,WMT	
		///	1	(1)	-	-		

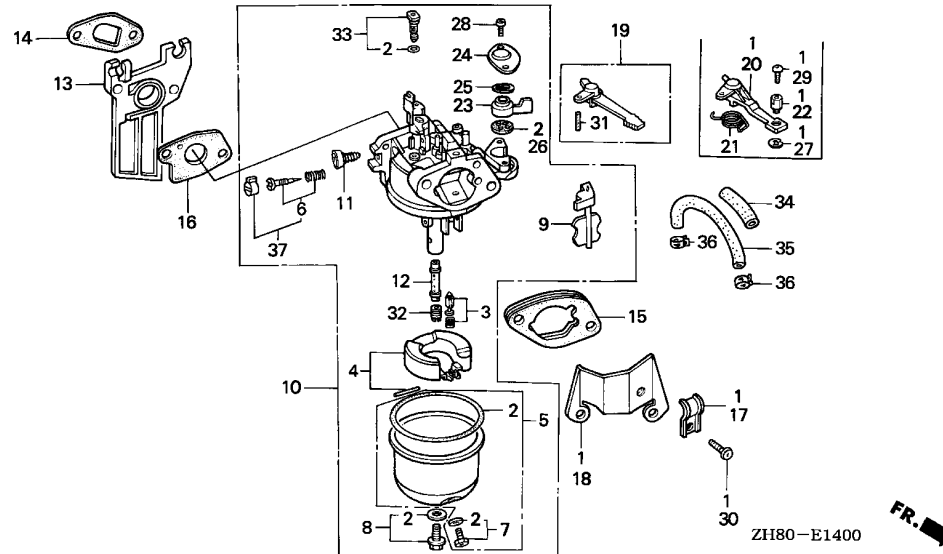

2

Ref. No.	Part No.	Description	Reqd. QTY				Serial No.	Parts catalogue code
			(1)	(2)	(3)	(4)		
15	16220-ZE1-020	SPACER COMP., CARBURETOR	1	-	-	-	-----	ARC6,LD,LDB1,LDB3,LDM,LD4,LSJ4,LTA,LW2,PM,PM2,QD,QE,QFE4,QM,QMC6,QNZ,RD,RD4,SD,SDB1,SDB3,SDS,SD16,SD4,SE,SEE,SWX,SW2,VEBM,WMB0,WME4,WMT
16	16221-ZH8-801	PACKING, CARBURETOR	1	(1)	-	-	-----	ARC6,H1,LD,LDB1,LDB3,LDM,LD4,LSJ4,LTA,LW2,L1,PM,PM2,QD,QE,QFE4,QM,QMC6,QNZ,Q1,RD,RD4,SD,SDB1,SDB3,SDS,SD16,SD4,SE,SEE,SWX,SW2,S1,T1,U1,VEBM,V1,WMB0,WME4,WMT,W1
17	16582-883-300	HOLDER, CONTROL CABLE	1	-	-	-	-----	R1 QNZ
18	16598-ZE1-000	STAY, CHOKE CONTROL	1	(1)	-	-	-----	QNZ
19	16610-ZE1-000	LEVER COMP., CHOKE (STD.)	1	-	-	-	-----	ARC6,LD,LDB1,LDB3,LDM,LD4,LSJ4,LTA,LW2,PM,PM2,QD,QE,QFE4,QM,QMC6,RD,RD4,SD,SDB1,SDB3,SDS,SD16,SD4,SE,SEE,SWX,SW2,VEBM,WMB0,WME4,WMT
20	16610-ZE1-810	LEVER COMP., CHOKE (REMOTE)	1	(1)	-	-	-----	QNZ
21	16615-ZE1-010	SPRING, RETURN	1	(1)	-	-	-----	QNZ
22	16617-890-010	HOLDER, CABLE	1	(1)	-	-	-----	QNZ
23	16953-ZE1-812	LEVER, COCK	1	-	-	-	-----	LD,LDB1,LDB3,LDM,LD4,LSJ4,LTA,LW2,PM,PM2,QD,QE,QFE4,QM,QMC6,QNZ,RD,RD4,SD,SDB1,SDB3,SDS,SD16,SD4,SE,SEE,SWX,SW2,VEBM,WMB0,WME4,WMT

Ref. No.	Part No.	Description	Reqd. QTY				Serial No.	Parts catalogue code
			(1)	(2)	(3)	(4)		
24	16954-ZE1-812	PLATE, LEVER SETTING	1	-	-	-	LD,LDB1,LDB3,LDM,LD4,LSJ4,LTA,LW2,PM,PM2,QD,QE,QFE4,QM,QMC6,QNZ,RD,RD4,SD,SDB1,SDB3,SDS,SD16,SD4,SE,SEE,SWX,SW2,VEBM,WMBOWME4,WMT	
			-	(1)	-	-		
25	16956-ZE1-811	SPRING, COCK LEVER	1	-	-	-	LD,LDB1,LDB3,LDM,LD4,LSJ4,LTA,LW2,PM,PM2,QD,QE,QFE4,QM,QMC6,QNZ,RD,RD4,SD,SDB1,SDB3,SDS,SD16,SD4,SE,SEE,SWX,SW2,VEBM,WMBOWME4,WMT	
			-	(1)	-	-		
26	16957-ZE1-812	PACKING, FUEL COCK	1	-	-	-	LD,LDB1,LDB3,LDM,LD4,LSJ4,LTA,LW2,PM,PM2,QD,QE,QFE4,QM,QMC6,QNZ,RD,RD4,SD,SDB1,SDB3,SDS,SD16,SD4,SE,SEE,SWX,SW2,VEBM,WMBOWME4,WMT	
			-	(1)	-	-		
27	90605-230-000	CIRCLIP, 5MM	1	-	-	-	QNZ	
			-	(1)	-	-		
28	93500-03008-1G	SCREW, PAN, 3X8 (CARBURETOR NO.)	2	-	-	-	BE06H B LD,LDB1,LDB3,LD4,LTA,LW2,PM,PM2,QD,QE,QM,QMC6,QNZ,RD,RD4,SD,SDB1,SDB3,SDS,SD16,SD4,SE,SEE,SWX,SW2,VEBM,WMBOWMT	
			-	(2)	-	-	BE06H B	
	93500-03006-1H	SCREW, PAN, 3X6 (CARBURETOR NO.)	2	(2)	-	-	BE06H C LD,LDB1,LDB3,LD4,LTA,LW2,PM,PM2,QD,QE,QM,QMC6,QNZ,Q1,RD,RD4,R1,SD,SDB1,SDB3,SDS,SD16,SD4,SE,SEE,SWX,SW2,S1,T1,VEBM,V1,WMBOWMT,W1	
			2	-	-	-	LDM,LSJ4,QFE4,WME4	
29	93500-04008-0A	SCREW, PAN, 4X8	1	-	-	-	QNZ	
			-	(1)	-	-		
30	93500-05008-0A	SCREW, PAN, 5X8	1	-	-	-	QNZ	
			-	(1)	-	-		
31	94305-20122	PIN, SPRING, 2X12	1	-	-	-	ARC6,LD,LDB1,LDB3,LDM,LD4,LSJ4,LTA,LW2,PM,PM2,QD,QE,QFE4,QM,QMC6,RD,RD4,SD,SDB1,SDB3,SDS,SD16,SD4,SE,SEE,SWX,SW2,VEBM,WMBOWME4,WMT	
			-	(1)	-	-		
32	99101-ZF5-0680	JET, MAIN, #68 (CARBURETOR NO.)	(1)	-	-	-	BE06H A LD,LTA,LW2,PM,PM2,QD,QE,QM,RD,SD,SDS,SE,SEE,SWX,SW2,VEBM	
			-	(1)	-	-	BE06H A	
	99101-ZF5-0700	JET, MAIN, #70 (CARBURETOR NO.)	(1)	-	-	-	BE06H A LD,LTA,LW2,PM,PM2,QD,QE,QM,RD,SD,SDS,SE,SEE,SWX,SW2,VEBM	
			-	(1)	-	-	BE06H A	
	99101-ZF5-0720	JET, MAIN, #72 (CARBURETOR NO.)	1	-	-	-	BE06H A LD,LTA,LW2,PM,PM2,QD,QE,QM,RD,SD,SDS,SE,SEE,SWX,SW2,VEBM	
			-	1	-	-	BE06H A	
	99101-ZH7-0650	JET, MAIN, #65 (CARBURETOR NO.)	(1)	(1)	-	-	BE06H B H1,LD,LTA,LW2,L1,PM,PM2,QD,QE,QM,RD,SD,SDS,SE,SEE,SWX,SW2,U1,VEBM	
	//		(1)	(1)	-	-	BE06H B BE06H B LDB1,LDB3,LD4,QMC6,QNZ,Q1,RD4,R1,SDB1,SDB3,SD16,SD4,S1,T1,V1,WMBOW1	
	99101-ZH7-0680	JET, MAIN, #68 (CARBURETOR NO.)	(1)	(1)	-	-	BE06H B H1,LD,LTA,LW2,L1,PM,PM2,QD,QE,QM,RD,SD,SDS,SE,SEE,SWX,SW2,U1,VEBM	
	//		(1)	(1)	-	-	BE06H B BE06H B LDB1,LDB3,LD4,QMC6,QNZ,Q1,RD4,R1,SDB1,SDB3,SD16,SD4,S1,T1,V1,WMBOW1	
	99101-ZH7-0700	JET, MAIN, #70 (CARBURETOR NO.)	1	1	-	-	BE06H B H1,LD,LTA,LW2,L1,PM,PM2,QD,QE,QM,RD,SD,SDS,SE,SEE,SWX,SW2,U1,VEBM	
	//		1	1	-	-	BE06H B BE06H B LDB1,LDB3,LD4,QMC6,QNZ,Q1,RD4,R1,SDB1,SDB3,SD16,SD4,S1,T1,V1,WMBOW1	



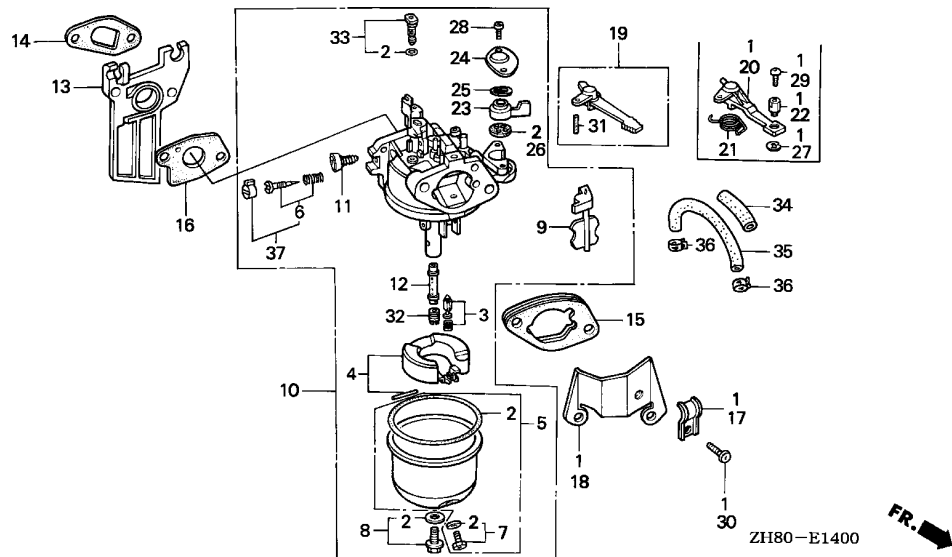

ZH80-E1400



Ref. No.	Part No.	Description	Reqd. QTY				Serial No.	Parts catalogue code
			(1)	(2)	(3)	(4)		
			GX160K1					
32)	99101-ZH8-0620	JET, MAIN, #62	(1)	-	-	-	ARC6	
	99101-ZH8-0650	JET, MAIN, #65 (CARBURETOR NO.)	(1)	(1)	-	-	ARC6,LDM,LSJ4,L1,QFE4,WME4,WMT	
	99101-ZH8-0680	JET, MAIN, #68 (CARBURETOR NO.)	1	(1)	-	-	LD,LDB1,LDB3,LD4,LTA,LW2,PM,PM2,QD,QE,QM,QMC6,QNZ,Q1,RD,RD4,R1	
	99101-ZH8-0700	JET, MAIN, #70 (CARBURETOR NO.)	(1)	(1)	-	-	SD,SDB1,SDB3,SDS,SD16,SD4,SE,SEE,SWX,SW2,S1,T1,VEBM,V1,WMB0,W1	
		(CARBURETOR NO.)	(1)	-	-	-	ARC6,L1	
		(CARBURETOR NO.)	1	-	-	-	LD,LDB1,LDB3,LD4,LTA,LW2,PM,PM2,QD,QE,QM,QMC6,QNZ,Q1,RD,RD4,R1	
		(CARBURETOR NO.)	1	-	-	-	SD,SDB1,SDB3,SDS,SD16,SD4,SE,SEE,SWX,SW2,S1,T1,VEBM,V1,WMB0,W1	
33	99204-ZE0-0380	JET SET, PILOT, #38 (CARBURETOR NO.)	-	(1)	-	-	LDM,LSJ4,QFE4,WME4,WMT	
		(CARBURETOR NO.)	1	-	-	-	LD,LDB1,LDB3,LD4,LTA,LW2,PM,PM2,QD,QE,QM,QMC6,QNZ,Q1,RD,RD4,R1	
		(CARBURETOR NO.)	-	(1)	-	-	SD,SDB1,SDB3,SDS,SD16,SD4,SE,SEE,SWX,SW2,S1,T1,VEBM,V1,WMB0,W1	
	99204-ZE2-0380	1	-	-	-	LDM,LSJ4,QFE4,WME4,WMT	
	99204-ZE0-0350	JET SET, PILOT, #35 (CARBURETOR NO.)	1	-	-	-	LD,LTA,LW2,PM,PM2,QD,QE,QM,QMC6,QNZ,RD4,SDB1,SDB3,SD16,SD4	
		(CARBURETOR NO.)	1	-	-	-	WMB0,WME4,WMT	
		(CARBURETOR NO.)	1	-	-	-	LD,LTA,LW2,PM,PM2,QD,QE,QM,QMC6,QNZ,RD4,SDB1,SDB3,SD16,SD4	
		(CARBURETOR NO.)	-	(1)	-	-	WMB0,WME4,WMT	
34	16854-ZH8-000	RUBBER, SUPPORTER (107MM)	1	-	-	-	ARC6	
35	95001-45400-60	TUBE, FUEL, 4.5X400 (95001-45001-60M)	1	-	-	-	ARC6	
36	95002-40800-08	CLAMP, TUBE (D8)	2	-	-	-	ARC6	

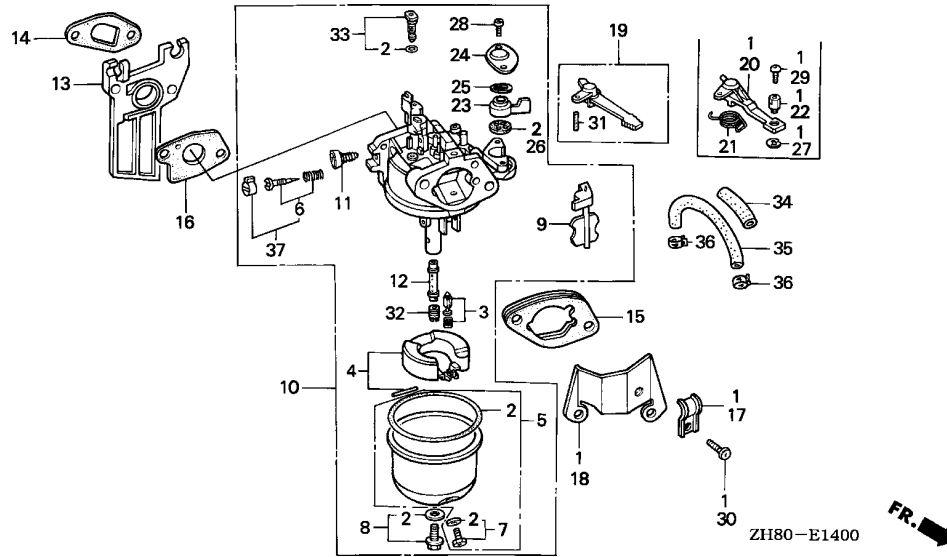

Ref. No.	Part No.	Description	Reqd. QTY				Serial No.	Parts catalogue code
			(1)	(2)	(3)	(4)		
			GX160K1					
37	16016-ZH7-W01	SCREW SET, PILOT (CARBURETOR NO.)	1	-	-	-	BE66E B ----- SD16,WME4,WMT	
		//	1	-	-	-	BE67C A ----- ARC6	



E-14-1

CARBURETOR(2)

L 1

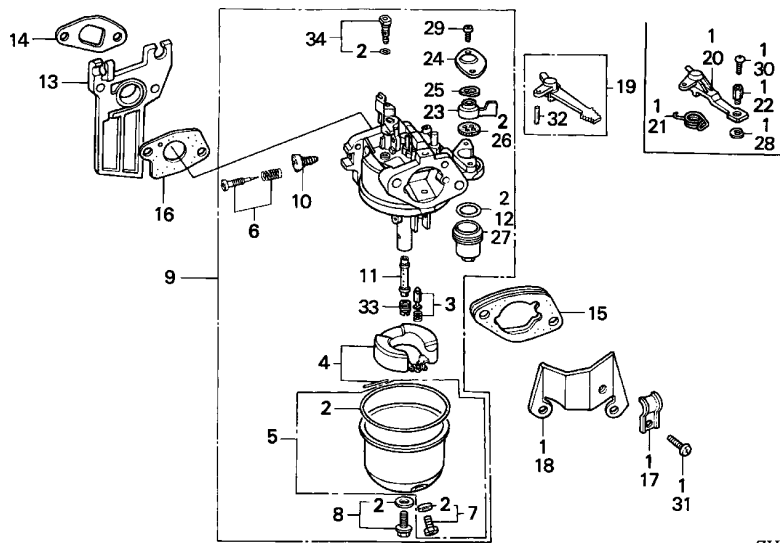

ZH80-E1401

Ref. No.	L.O.N.	(Relative ref. Number) Description	F.R.T.
1	8101C4	CHOKE KIT, REMOTE CONTROL (4)	0.2
3	3111E1	VALVE SET, FLOAT AND/OR FLOAT SET	0.3
6	3111D7	SCREW SET, PILOT	0.2
9	3111F3	CARBURETOR (14)	0.2
13	3111C0	INSULATOR, CARBURETOR AND/OR PACKING, INSULATOR	0.2
16	3111C8	PACKING, CARBURETOR	0.2
19	8101F9	LEVER, CARBURETOR CHOKE	0.2
26	3101C5	PACKING, FUEL COCK	0.2
33	3111C3	JET, MAIN	0.3

2

Ref. No.	Part No.	Description	Reqd. QTY				Serial No.	Parts catalogue code
			(1)	(2)	(3)	(4)		
			GX160K1					
1	06164-ZE1-000	CHOKE KIT, REMOTE CONTROL ...	(1)	-	-	-		
2	16010-ZE1-812	GASKET SET	1	-	-	-	LSS4,QNT4	
3	16011-ZE0-005	VALVE SET, FLOAT	1	-	-	-	LSS4,QNT4	
4	16013-ZE0-005	FLOAT SET	1	-	-	-	LSS4,QNT4	
5	16015-ZE1-811	CHAMBER SET, FLOAT (CARBURETOR NO.)	-	(1)	-	-	H1,U1	
	16015-ZE0-831	(CARBURETOR NO.)	1	-	-	-	BE11C A L1,Q1,R1,S1,T1,V1,W1	
		(CARBURETOR NO.)	-	(1)	-	-	LSS4,QNT4	
			-	(1)	-	-	BE11C B L1,Q1,R1,S1,T1,V1,W1	
6	16016-ZE0-005	SCREW SET, PILOT	1	-	-	-	LSS4,QNT4	
7	16024-ZE1-811	SCREW SET, DRAIN	1	-	-	-	LSS4,QNT4	
8	16028-ZE0-005	SCREW SET	1	-	-	-	LSS4,QNT4	
9	16100-ZH8-800	CARBURETOR ASSY. (BE11C A)	-	(1)	-	-	H1,U1	
	16100-ZH8-801	CARBURETOR ASSY. (BE11C B)	1	-	-	-	4047733 L1,Q1,R1,S1,T1,V1,W1	
			-	(1)	-	-	LSS4,QNT4	
10	16124-ZE0-005	SCREW, THROTTLE STOP	1	-	-	-	4047734 L1,Q1,R1,S1,T1,V1,W1	
			-	(1)	-	-	LSS4,QNT4	
11	16166-ZH8-800	NOZZLE, MAIN	1	-	-	-	LSS4,QNT4	
			-	(1)	-	-		

E-14-1

CARBURETOR(2)

L 2

Ref. No.	Part No.	Description	Reqd. QTY				Serial No.	Parts catalogue code
			(1)	(2)	(3)	(4)		
12	16173-001-004	PACKING, FUEL STRAINER CUP ..	1	-	-	-	LSS4,QNT4	
13	16211-ZE1-000	INSULATOR, CARBURETOR	1	(1)	-	-	LSS4,QNT4	
14	16212-ZH8-800	PACKING, INSULATOR	1	-	-	-	LSS4,QNT4	
	16212-ZH8-000	-	1	-	-		
15	16220-ZE1-020	SPACER COMP., CARBURETOR	1	-	-	-	LSS4,QNT4	
			-	1	-	-		
16	16221-ZH8-801	PACKING, CARBURETOR	1	1	-	-	LSS4,L1,QNT4,Q1,R1,S1,T1,V1,W1	
	16221-ZE1-000	-	(1)	-	2630823		
	16221-ZH8-800	-	(1)	-	2630824		
17	16582-883-300	HOLDER, CONTROL CABLE	-	(1)	-	-		
18	16598-ZE1-000	STAY, CHOKE CONTROL	-	(1)	-	-		
19	16610-ZE1-000	LEVER COMP., CHOKE (STD.) ...	1	-	-	-	LSS4,QNT4	
			-	(1)	-	-		
20	16610-ZE1-810	LEVER COMP., CHOKE (REMOTE) ..	-	(1)	-	-		
21	16615-ZE1-010	SPRING, RETURN	-	(1)	-	-		
22	16617-890-010	HOLDER, CABLE	-	(1)	-	-		
23	16953-ZE1-812	LEVER, COCK	1	-	-	-	LSS4,QNT4	
			-	(1)	-	-		
24	16954-ZE1-812	PLATE, LEVER SETTING	1	-	-	-	LSS4,QNT4	
			-	(1)	-	-		
25	16956-ZE1-811	SPRING, COCK LEVER	1	-	-	-	LSS4,QNT4	
			-	(1)	-	-		
26	16957-ZE1-812	PACKING, FUEL COCK	1	-	-	-	LSS4,QNT4	
			-	(1)	-	-		
27	16967-ZE0-811	CUP, FUEL STRAINER	1	-	-	-	LSS4,QNT4	
			-	(1)	-	-		
28	90605-230-000	CIRCLIP, 5MM	-	(1)	-	-		
29	93500-03008-1G	SCREW, PAN, 3X8	-	(2)	-	-	H1,U1	
		(CARBURETOR NO.)	-	(2)	-	BE11C A	L1,Q1,R1,S1,T1,V1,W1	
	93500-03006-1H	SCREW, PAN, 3X6	2	-	-	-	LSS4,QNT4	
		(CARBURETOR NO.)	-	(2)	-	BE11C B	L1,Q1,R1,S1,T1,V1,W1	
30	93500-04008-0A	SCREW, PAN, 4X8	-	(1)	-	-		
31	93500-05008-0A	SCREW, PAN, 5X8	-	(1)	-	-		
32	94305-20122	PIN, SPRING, 2X12	1	-	-	-	LSS4,QNT4	
			-	(1)	-	-		
33	99101-ZF5-0620	JET, MAIN, #62	-	(1)	-	-	H1,U1	
		(CARBURETOR NO.)	-	(1)	-	BE11C A	L1,Q1,R1,S1,T1,V1,W1	
	99101-ZF5-0650	JET, MAIN, #65	-	(1)	-	-	H1,U1	
		(CARBURETOR NO.)	-	(1)	-	BE11C A	L1,Q1,R1,S1,T1,V1,W1	
	99101-ZF5-0680	JET, MAIN, #68	-	1	-	-	H1,U1	
		(CARBURETOR NO.)	-	1	-	BE11C A	L1,Q1,R1,S1,T1,V1,W1	
	99101-ZH8-0620	JET, MAIN, #62	(1)	-	-	-	LSS4,QNT4	
		(CARBURETOR NO.)	-	(1)	-	BE11C B	L1,Q1,R1,S1,T1,V1,W1	
	99101-ZH8-0650	JET, MAIN, #65	(1)	-	-	-	LSS4,QNT4	
		(CARBURETOR NO.)	-	(1)	-	BE11C B	L1,Q1,R1,S1,T1,V1,W1	
	99101-ZH8-0680	JET, MAIN, #68	1	-	-	-	LSS4,QNT4	
		(CARBURETOR NO.)	-	1	-	BE11C B	L1,Q1,R1,S1,T1,V1,W1	
34	99204-ZE0-0380	JET SET, PILOT, #38	1	-	-	-	LSS4,QNT4	
			-	(1)	-	-		

2

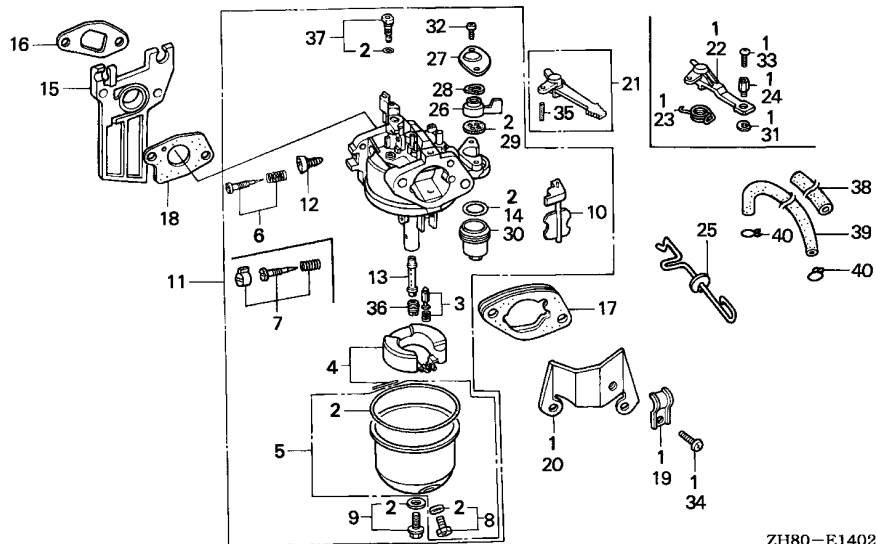

ZH80-E1402



Ref. No.	L.O.N.	(Relative ref. Number) Description	F.R.T.
1	8101C4	CHOKE KIT, REMOTE CONTROL (4)	0.2
3	3111E1	VALVE SET, FLOAT AND/OR FLOAT SET (7)	0.3
6	3111D7	SCREW SET, PILOT	0.2
11	3111F3	CARBURETOR (16)	0.2
15	3111C0	INSULATOR, CARBURETOR AND/OR PACKING, INSULATOR	0.2
18	3111C8	PACKING, CARBURETOR	0.2
21	8101F9	LEVER, CARBURETOR CHOKE	0.2
25	8101R4	ROD, THROTTLE	0.2
29	3101C5	PACKING, FUEL COCK	0.2
36	3111C3	JET, MAIN	0.3
39	3101F6	TUBE, FUEL	0.2

2

Ref. No.	Part No.	Description	Reqd. QTY				Serial No.	Parts catalogue code
			(1)	(2)	(3)	(4)		
1	06164-ZE1-000	CHOKE KIT, REMOTE CONTROL ...	1	-	-	-	QXW,QXW2	
			(1)	-	-	-	HG1	
2	16010-ZE1-812	GASKET SET	1	-	-	-	BL,DS,DSP,EN,ET,ETX,HG1,HG12,HH,HHQ4,HH26,HX,HXE,HXE2,HXE8,HXQ HXU,HX2,HX26,HX4,KTA,LAX,LAX2,LH,LHB3,LHQ4,LHW,LJ,LJC7,LJD,LJG LJS,LMT,LSJ,LSS,LSS1,LTK,LVL,LX,LXU,LX2,LX26,LX4,NJ,NJG,NSJ,NW PH,PHM,PX,PXU,PX2,QA,QAB1,QAB3,QAX,QAX2,QA2,QA26,QBC2,QBT2 QBT6,QBU2,QCB2,QCL,QGR2,QGR9,QH,QHE,QHP1,QHQ4,QH26,QI2,QKA4 QMC8,QMD6,QME4,QMH,QMX2,QM2,QNT,QNT2,QP,QPU,QSC2,QSC9,QS2,QT QVL,QWA4,QWM2,QWX2,QWX3,QX,QXB,QXB1,QXC,QXC6,QXC9,QXE,QXE2 QXE4,QXE6,QXE8,QXF,QXF2,QXM1,QXQ,QXS,QXS2,QXU,QXW,QXW2,QX2 QX22,QX26,QX4,QX7,QZ,RAC,REX4,RFR,RFR2,RH,RHA,RHA2,RHQ4,RH2 RH26,RMB4,RMD,RMG2,RNG,RSK,RSS1,RTB2,RX,RXE,RXE2,RXE4,RXU,RX4 SAC,SAD2,SCJ,SDN,SDS2,SDS3,SG24,SH,SHM,SHQ4,SHRY,SHR4,SJ,SJC SJC1,SJC5,SJG,SKM,SMB4,SMC7,SMC9,SMJ,SMJ1,SMW2,SMX4,SM11,SM12 SM14,SNX,SNX1,SSK1,SSK2,SSX2,STA,STP,STQ,SWG4,SWX2,SWX4,SX,SB SXE,SXE4,SXS4,SXU,SX4,SX7,S1CY,TCS2,TH,TX,TXC9,TXU,TX2,TX26 TX4,UH,UX,UXU,VA,VA2,VED,VED1,VED5,VED6,VGE4,VH,VHA7,VHH4,VHQ4 VMB3,VMS4,VMS7,VS,VSD,VSD7,VSX,VSX1,VSX3,VS1,VTD,VTD1,VTU1,VVA VVA2,VW12,VX,VXD,VXD1,VXE,VXE4,VXE6,VXE7,VXG,VXM,VXU,VXU1,VXW VXW1,VXW2,VX2,VX26,VX4,WDA6,WJP,WKD6,WKT2,WKT4,WKT6,WME2	
	(CARBURETOR NO.)		1	-	-	-	BE06J A ST	
	16010-ZE0-025	1	(1)	1	-	PHU,THU,VEB2,VG24	
	16010-ZH7-A20	1	-	-	-	STM	
	(CARBURETOR NO.)		1	-	-	-	BE06R A ST	
	16010-ZB1-015	1	-	-	-	AR	

Ref. No.	Part No.	Description	Reqd. QTY				Serial No.	Parts catalogue code
			(1)	(2)	(3)	(4)		
3	16011-ZE0-005	VALVE SET, FLOAT	1	-	-	-	AR, BL, DS, DSP, EN, ET, ETX, HG1, HG12, HH, HHQ4, HH26, HX, HXE, HXE2, HXE8, HXQ, HXU, HX2, HX26, HX4, KTA, LAX, LAX2, LH, LHQ4, LHB3, LHQ4, LHW, LJ, LJ7, LJ7C, LJ7D, LJG, LJS, LMT, LSJ, LSS, LSS1, LTK, LVL, LX, LXU, LX2, LX26, LX4, NJ, NJG, NSJ, NW, PH, PHM, PHU, PX, PXU, PX2, QA, QAB1, QAB3, QAX, QAX2, QA2, QA26, QBC2, QBT2, QBT6, QBU2, QCB2, QCL, QGR2, QGR9, QH, QHE, QHP1, QHQ4, QH26, QI2, QKA4, QMC8, QMD6, QME4, QMH, QMX2, QMZ2, QNT, QNT2, QP, QPU, QSC2, QSC9, QS2, QT, QVL, QWA4, QWM2, QWX2, QWX3, QX, QXB, QXB1, QXC, QXC6, QXC9, QXE, QXE2, QXE4, QXE6, QXE8, QXF, QXF2, QXM1, QXQ, QXS, QXS2, QXU, QXW, QXW2, QX2, QX22, QX26, QX4, QX7, QZ, RAC, REX4, RFR, RFR2, RH, RHA, RHA2, RHQ4, RH2, RH26, RMB4, RMD, RMG2, RNG, RSK, RSS1, RTB2, RX, RXE, RXE2, RXE4, RXU, RX4, SAC, SAD2, SCJ, SDN, SDS2, SDS3, SG24, SH, SHM, SHQ4, SHRY, SHR4, SJ, SJC, SJC1, SJC5, SJG, SKM, SMB4, SMC7, SMC9, SMJ, SMJ1, SMW2, SMX4, SM11, SM12, SM14, SNX, SNX1, SSK1, SSK2, SSX2, ST, STA, STM, STP, STQ, SWG4, SWX2, SWX4, SX, SXB, SXE, SXE4, SXS4, SXU, SX4, SX7, S1CY, TCS2, TH, THU, TX, TXC9, TXU, TX2, TX26, TX4, UH, UX, UXU, VA, VA2, VEB2, VED, VED1, VED5, VED6, VGE4, VG24, VH, VHA7, VHH4, VHQ4, VMB3, VMS4, VMS7, VS, VSD, VSD7, VSX, VSX1, VSX3, VS1, VTD, VTD1, VTU1, VWA, VWA2, VW12, VX, VXD, VXD1, VXE, VXE4, VXE6, VXE7, VXG, VXM, VXU, VXU1, VXW, VXW1, VXW2, VX2, VX26, VX4, WDA6, WJP, WKD6, WKT2, WKT4, WKT6, WME2	
			-	(1)	1	-		
4	16013-ZE0-005	FLOAT SET	1	-	-	-	AR, BL, DS, DSP, EN, ET, ETX, HG1, HG12, HH, HHQ4, HH26, HX, HXE, HXE2, HXE8, HXQ, HXU, HX2, HX26, HX4, KTA, LAX, LAX2, LH, LHQ4, LHB3, LHQ4, LHW, LJ, LJ7, LJ7C, LJ7D, LJG, LJS, LMT, LSJ, LSS, LSS1, LTK, LVL, LX, LXU, LX2, LX26, LX4, NJ, NJG, NSJ, NW, PH, PHM, PHU, PX, PXU, PX2, QA, QAB1, QAB3, QAX, QAX2, QA2, QA26, QBC2, QBT2, QBT6, QBU2, QCB2, QCL, QGR2, QGR9, QH, QHE, QHP1, QHQ4, QH26, QI2, QKA4, QMC8, QMD6, QME4, QMH, QMX2, QMZ2, QNT, QNT2, QP, QPU, QSC2, QSC9, QS2, QT, QVL, QWA4, QWM2, QWX2, QWX3, QX, QXB, QXB1, QXC, QXC6, QXC9, QXE, QXE2, QXE4, QXE6, QXE8, QXF, QXF2, QXM1, QXQ, QXS, QXS2, QXU, QXW, QXW2, QX2, QX22, QX26, QX4, QX7, QZ, RAC, REX4, RFR, RFR2, RH, RHA, RHA2, RHQ4, RH2, RH26, RMB4, RMD, RMG2, RNG, RSK, RSS1, RTB2, RX, RXE, RXE2, RXE4, RXU, RX4, SAC, SAD2, SCJ, SDN, SDS2, SDS3, SG24, SH, SHM, SHQ4, SHRY, SHR4, SJ, SJC, SJC1, SJC5, SJG, SKM, SMB4, SMC7, SMC9, SMJ, SMJ1, SMW2, SMX4, SM11, SM12, SM14, SNX, SNX1, SSK1, SSK2, SSX2, ST, STA, STM, STP, STQ, SWG4, SWX2, SWX4, SX, SXB, SXE, SXE4, SXS4, SXU, SX4, SX7, S1CY, TCS2, TH, THU, TX, TXC9, TXU, TX2, TX26, TX4, UH, UX, UXU, VA, VA2, VEB2, VED, VED1, VED5, VED6, VGE4, VG24, VH, VHA7, VHH4, VHQ4, VMB3, VMS4, VMS7, VS, VSD, VSD7, VSX, VSX1, VSX3, VS1, VTD, VTD1, VTU1, VWA, VWA2, VW12, VX, VXD, VXD1, VXE, VXE4, VXE6, VXE7, VXG, VXM, VXU, VXU1, VXW, VXW1, VXW2, VX2, VX26, VX4, WDA6, WJP, WKD6, WKT2, WKT4, WKT6, WME2	
			-	(1)	1	-		



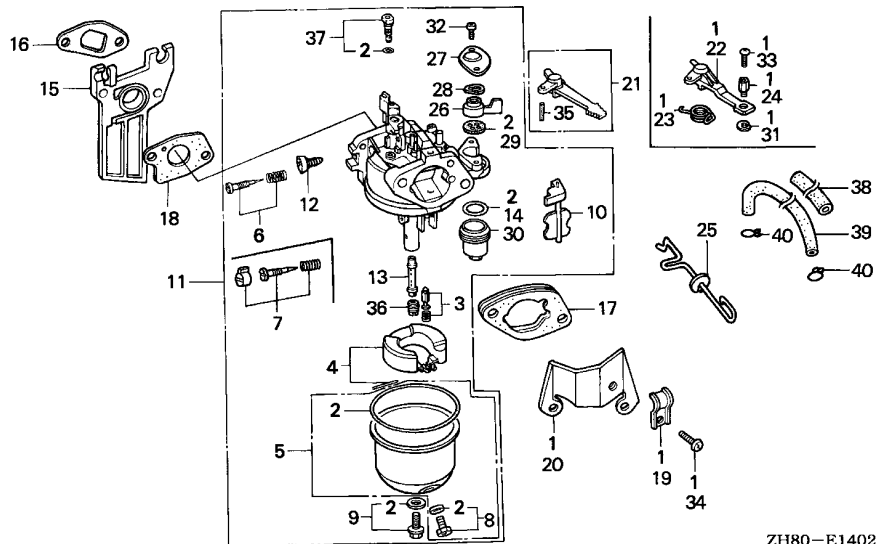

Ref. No.	Part No.	Description	Reqd. QTY				Serial No.	Parts catalogue code
			(1)	(2)	(3)	(4)		
			GX160K1					
5	16015-ZE1-811	CHAMBER SET, FLOAT (CARBURETOR NO.)	1	(1)	1	-	AR,H1,L1,UIH,U1	
		///	1	(1)	-	-	BE06J B DS,DSP,EN,ET,ETX,HG1,HH,HHQ4,HX,HXE,HX4,KTA,LAX,LH,LHB3,LHQ4 LJ,LJD,LJG,LJS,LMT,LSS,LSS1,LTK,LX,LX4,NJ,NJG,PH,PX,QA,QAB1 QAB3,QAX,QH,QHE,QHQ4,QKA4,QMC8,QMD6,QME4,QNT,QP,QPU,QT,QX,QXB QXB1,QXE,QXE4,QXF,QXS,QXW,QX4,Q1,RAC,RFR,RH,RHA,RHQ4,RMB4,RMD RNG,RSK,RX,RXE,RXE4,RX4,R1,SAC,SCJ,SDS2,SDS3,SH,SHQ4,SJ,SJC SJG,SMB4,SMC7,SMC9,SMJ,SMJ1,SNX,SSK1,STA,STP,STQ,SWG4,SX,SXB SXE,SXE4,SX4,S1,TH,TX,TX4,T1,UH,UX,VA,VED,VED1,VED5,VGE4,VH VHH4,VHQ4,VMB3,VMS4,VS,VSD,VSX,VSX1,VS1,VVA,VX,VXD,VXD1,VXE VXE4,VXG,VXU,VXW,VXW1,VX4,V1,WJP,W1	
		///	1	-	-	-	BE06J A ST	
		///	1	-	-	-	BE06S A QZ	
		///	1	-	-	-	BE06U A PHU,THU	
		///	1	-	-	-	BE07C A SKM	
		///	1	-	-	-	BE11C A QXC	
		///	1	-	-	-	BE65A A HXQ,QXQ	
		///	1	-	-	-	BE65B A HG12,HH26,HX2,HX26,LAX2,LX2,LX26,PX2,QAX2,QBT2,QBT6,QBU2,QGR2 QH26,QMX2,QM22,QNT2,QXE2,QXE6,QXF2,QXS2,QXW2,QX2,QX26,RFR2 RHA2,RH2,RH26,RMG2,RTB2,SAD2,SG24,SMW2,SSK2,SSX2,TX2,TX26,VA2 VWA2,VW12,VXW2,VX2,VX26	
		///	1	-	-	-	BE65C A QA2,QA26,WKT2,WME2	
		///	1	-	-	-	BE65G A QSC2,QXC6,QXC9,TXC9	
		///	1	-	-	-	BE66D A VEB2,VG24	

E-14-2

CARBURETOR(3)

L 6

Ref. No.	Part No.	Description	Reqd. QTY				Serial No.	Parts catalogue code
			GX160K1					
			(1)	(2)	(3)	(4)		
(5)	16015-ZE0-831	CHAMBER SET, FLOAT (CARBURETOR NO.)	1	(1)	-	-	BE06J C	DS,DSP,EN,ET,ETX,HG1,HH,HHQ4,HX,HXE,HX4,KTA,LAX,LH,LHB3,LHQ4,LJ,LJD,LJG,LJS,LMT,LSS,LSS1,LTK,LX,LX4,NJ,NJG,PH,PX,QA,QAB1,QAB3,QAX,QH,QHE,QHQ4,QKA4,QMC8,QMD6,QME4,QNT,QP,QPU,QT,QX,QXB,QXB1,QXE,QXE4,QXF,QXS,QXW,QX4,Q1,RAC,RFR,RH,RHA,RHQ4,RMB4,RMD,RNG,RSK,RX,RXE,RXE4,RX4,R1,SAC,SCJ,SDS2,SDS3,SH,SHQ4,SJ,SJC,SJG,SMB4,SMC7,SMC9,SMJ,SMJ1,SNX,SSK1,STA,STP,STQ,SWG4,SX,SXB,SXE,SXE4,SX4,S1,TH,TX,TX4,T1,UH,UX,VA,VED,VED1,VED5,VGE4,VH,VHH4,VHQ4,VMB3,VMS4,VS,VSD,VSX,VSX1,VS1,VVA,VX,VXD,VXD1,VXE,VXE4,VXG,VXU,VXW,VXW1,VX4,V1,WJP,W1
		(CARBURETOR NO.)	1	-	1	-		BL,HXE2,HXE8,HXU,LHW,LJC7,LSJ,LVL,LXU,NSJ,NW,PHM,PXU,QBC2,QCB2,QCL,QGR9,QHP1,QIH1,QI2,QMH,QSC9,QS2,QVL,QWA4,QWM2,QWX2,QWX3,QXE8,QXM1,QXU,QX22,QX7,REX4,RSS1,RXE2,RXU,SDN,SHM,SHRY,SHR4,SJC1,SJC5,SMX4,SM11,SM12,SM14,SNX1,SWX2,SWX4,SXS4,SXU, SX7,S1CY,TCS2,TXU,UXU,VED6,VHA7,VIH1,VMS7,VSD7,VSX3, VTD, VTD1,VTU1,VXE6,VXE7,VXM,VXU1,WDA6,WIH1,WKD6,WKT4,WKT6
		//	1	-	-	-	BE06S B	QZ
		//	1	-	-	-	BE06U B	PHU,THU
		//	1	-	-	-	BE07C B	SKM
		//	1	-	-	-	BE11C B	QXC
		//	1	-	-	-	BE65A B	HXQ,QXQ
		//	1	-	-	-	BE65B B	HG12,HH26,HX2,HX26,LAX2,LX2,LX26,PX2,QAX2,QBT2,QBT6,QBU2,QGR2,QH26,QMX2,QMZ2,QNT2,QXE2,QXE6,QXF2,QXS2,QXW2,QX2,QX26,RFR2,RHA2,RH2,RH26,RMG2,RTB2,SAD2,SG24,SMW2,SSK2,SSX2,TX2,TX26,VA2,VWA2,VW12,VXW2,VX2,VX26
		//	1	-	-	-	BE65C B	QA2,QA26,WKT2,WME2
		//	1	-	-	-	BE65G B	QSC2,QXC6,QXC9,TXC9
		//	1	-	-	-	BE66D B	VEB2,VG24
	16015-ZH7-A20	(CARBURETOR NO.)	1	-	-	-	BE06R A	STM
		//	1	-	-	-	BE06R A	BE06R A ST
	16015-ZH7-A21	(CARBURETOR NO.)	1	-	-	-	BE06R B	ST,STM
6	16016-ZE0-005	SCREW SET, PILOT	1	-	1	-		BL,EN,ET,ETX,HG1,HH,HHQ4,HXE,HXE8,HX4,KTA,LAX,LH,LHB3,LHQ4,LHW,LJD,LJS,LMT,LSS1,LTK,LVL,LX,LXU,LX4,NW,PH,PHM,PHU,PX, PXU,QAB1,QAB3,QAX,QH,QHE,QHP1,QHQ4,QIH1,QKA4,QMC8,QMD6,QME4,QMH,QNT,QP,QPU,QT,QVL,QXB,QXB1,QXE4,QXE8,QXF,QXM1,QXS,QXU,QXW,QX4,QZ,RAC,REX4,RFR,RHA,RHQ4,RMB4,RMD,RSK,RX,RXE,RXE4,RXU,RX4,SAC,SDN,SDS2,SDS3,SH,SHM,SHQ4,SKM,SMB4,SMC7,SMC9,SMJ,SM11,SNX,SNX1,ST,STA,STM,SWG4,SX,SXB,SXE,SXE4,SXU,SX4,TH,THU,TXU,TX4,UH,UIH,UX,UXU,VA,VED,VED1,VGE4,VH,VHH4,VHQ4,VMB3,VMS4,VS,VSD,VSX,VSX1,VS1,VTD,VTD1,VTU1,VVA,VXE,VXE4,VXG,VXM,VXU,VXW,VXW1,VX4,WIH1
		(CARBURETOR NO.)	1	-	1	-	BE06J C	DS,DSP,HX,LJ,LJC7,LJG,LSJ,LSS,NJ,NJG,NSJ,QA,QX,QXE,RH,RNG,RSS1,SCJ,SHRY,SHR4,SJ,SJC,SJC1,SJC5,SJG,SMJ1,SM14,SSK1,STP,STQ,S1CY,TX,VED5,VIH1,VSX3,VX,VXD,VXD1,VXU1,WJP
		//	1	-	-	-	BE11C B	QXC
		//	1	-	-	-	BE67A B	AR
			-	(1)	-	-		

2

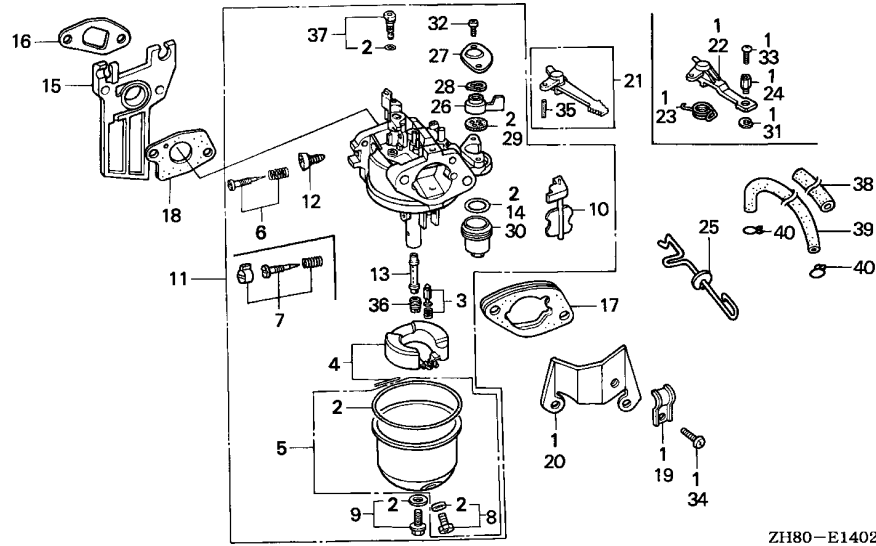

ZH80-E1402



Ref. No.	Part No.	Description	Reqd. QTY				Serial No.	Parts catalogue code
			(1)	(2)	(3)	(4)		
7	16016-ZH7-W01	SCREW SET, PILOT (CARBURETOR NO.)	1	-	1	-	BE65B B	HX,LSJ,QX,QXE,RH,SHR4,SMJ1,SM14,SSK1,STP,STQ,S1CY,TX,VIH1,VSX3 VX,VXU1
			1	-	-	-		HG12,HH26,HXE2,HX2,HX26,LAX2,LX2,LX26,PX2,QAX2,QA2,QA26,QBC2 QBT2,QBT6,QBU2,QCB2,QCL,QGR2,QGR9,QH26,QI2,QMX2,QMZ2,QNT2,QS2 QWA4,QWM2,QWX2,QWX3,QXE2,QXE6,QXF2,QXS2,QXW2,QX2,QX22,QX26,QX7 RFR2,RHA2,RH2,RH26,RMG2,RTB2,RXE2,SAD2,SG24,SMW2,SMX4,SM12 SSK2,SSX2,SWX2,SWX4,SXS4,SX7,TCS2,TX2,TX26,VA2,VEB2,VED6,VG24 VHA7,VMS7,VSD7,VWA2,VW12,VXE6,VXE7,VXW2,VX2,VX26,WDA6,WKD6 WKT2,WKT4,WKT6,WME2
		(CARBURETOR NO.)	1	-	-	-	BE65C B	DS,DSP,LJ,LJC7,LJG,LSS,NJ,NJG,NSJ,QA,RNG,RSS1,SCJ,SHRY,SJ,SJC SJC1,SJC5,SJG,VED5,VXD,VXD1,WJP
	16016-ZH8-W01	SCREW SET (CARBURETOR NO.)	1	-	-	-	BE67C A	AR
			1	-	-	-	BE65G B	HXQ,QSC2,QSC9,QXC6,QXC9,QXQ,TXC9
			1	-	-	-		QXC

Ref. No.	Part No.	Description	Reqd. QTY				Serial No.	Parts catalogue code
			(1)	(2)	(3)	(4)		
8	16024-ZE1-811	SCREW SET, DRAIN	1	-	-	-	AR, BL, DS, DSP, EN, ET, ETX, HG1, HG12, HH, HHQ4, HH26, HX, HXE, HXE2, HXE8, HXQ, HXU, HX2, HX26, HX4, KTA, LAX, LAX2, LH, LHB3, LHQ4, LHW, LJ, LJ7, LJ8, LJ9, LJS, LMT, LSJ, LSS, LSS1, LTK, LVL, LX, LXU, LX2, LX26, LX4, NJ, NJG, NSJ, NW, PH, PHM, PHU, PX, PXU, PX2, QA, QAB1, QAB3, QAX, QAX2, QA2, QA26, QBC2, QBT2, QBT6, QBU2, QCB2, QCL, QGR2, QGR9, QH, QHE, QHP1, QHQ4, QH26, QI2, QKA4, QMC8, QMD6, QME4, QMH, QMX2, QM22, QNT, QNT2, QP, QPU, QSC2, QSC9, QS2, QT, QVL, QWA4, QWM2, QWX2, QWX3, QX, QXB, QXB1, QXC, QXC6, QXC9, QXE, QXE2, QXE4, QXE6, QXE8, QXF, QXF2, QXM1, QXQ, QXS, QXS2, QXU, QXW, QXW2, QX2, QX22, QX26, QX4, QX7, QZ, RAC, REX4, RFR, RFR2, RH, RHA, RHA2, RHQ4, RH2, RH26, RMB4, RMD, RMG2, RNG, RSK, RSS1, RTB2, RX, RXE, RXE2, RXE4, RXU, RX4, SAC, SAD2, SCJ, SDN, SDS2, SDS3, SG24, SH, SHM, SHQ4, SHRY, SHR4, SJ, SJC, SJC1, SJC5, SJG, SKM, SMB4, SMC7, SMC9, SMJ, SMJ1, SMW2, SMX4, SM11, SM12, SM14, SNX, SNX1, SSK1, SSK2, SXX2, STA, STP, STQ, SWG4, SWX2, SWX4, SX, SXB, SXE, SXE4, SXS4, SXU, SX4, SX7, S1CY, TCS2, TH, THU, TX, TXC9, TXU, TX2, TX26, TX4, UH, UX, UXU, VA, VA2, VEB2, VED, VED1, VED5, VED6, VGE4, VG24, VH, VHA7, VHH4, VHQ4, VMB3, VMS4, VMS7, VS, VSD, VSD7, VSX, VSX1, VSX3, VS1, VTD, VTD1, VTU1, VWA, VWA2, VW12, VX, VXD, VXD1, VXE, VXE4, VXE6, VXE7, VXG, VXM, VXU, VXU1, VXW, VXW1, VXW2, VX2, VX26, VX4, WDA6, WJP, WKD6, WKT2, WKT4, WKT6, WME2	
		(CARBURETOR NO.)	1	-	-	-	BE06J A ST	
	16024-ZH7-A20	1	(1)	1	-	STM	
		(CARBURETOR NO.)	1	-	-	-	BE06R A	
9	16028-ZE0-005	SCREW SET	1	-	-	-	AR, BL, DS, DSP, EN, ET, ETX, HG1, HG12, HH, HHQ4, HH26, HX, HXE, HXE2, HXE8, HXQ, HXU, HX2, HX26, HX4, KTA, LAX, LAX2, LH, LHB3, LHQ4, LHW, LJ, LJ7, LJ8, LJ9, LJS, LMT, LSJ, LSS, LSS1, LTK, LVL, LX, LXU, LX2, LX26, LX4, NJ, NJG, NSJ, NW, PH, PHM, PHU, PX, PXU, PX2, QA, QAB1, QAB3, QAX, QAX2, QA2, QA26, QBC2, QBT2, QBT6, QBU2, QCB2, QCL, QGR2, QGR9, QH, QHE, QHP1, QHQ4, QH26, QI2, QKA4, QMC8, QMD6, QME4, QMH, QMX2, QM22, QNT, QNT2, QP, QPU, QSC2, QSC9, QS2, QT, QVL, QWA4, QWM2, QWX2, QWX3, QX, QXB, QXB1, QXC, QXC6, QXC9, QXE, QXE2, QXE4, QXE6, QXE8, QXF, QXF2, QXM1, QXQ, QXS, QXS2, QXU, QXW, QXW2, QX2, QX22, QX26, QX4, QX7, QZ, RAC, REX4, RFR, RFR2, RH, RHA, RHA2, RHQ4, RH2, RH26, RMB4, RMD, RMG2, RNG, RSK, RSS1, RTB2, RX, RXE, RXE2, RXE4, RXU, RX4, SAC, SAD2, SCJ, SDN, SDS2, SDS3, SG24, SH, SHM, SHQ4, SHRY, SHR4, SJ, SJC, SJC1, SJC5, SJG, SKM, SMB4, SMC7, SMC9, SMJ, SMJ1, SMW2, SMX4, SM11, SM12, SM14, SNX, SNX1, SSK1, SSK2, SXX2, ST, STA, STM, STP, STQ, SWG4, SWX2, SWX4, SX, SXB, SXE, SXE4, SXS4, SXU, SX4, SX7, S1CY, TCS2, TH, THU, TX, TXC9, TXU, TX2, TX26, TX4, UH, UX, UXU, VA, VA2, VEB2, VED, VED1, VED5, VED6, VGE4, VG24, VH, VHA7, VHH4, VHQ4, VMB3, VMS4, VMS7, VS, VSD, VSD7, VSX, VSX1, VSX3, VS1, VTD, VTD1, VTU1, VWA, VWA2, VW12, VX, VXD, VXD1, VXE, VXE4, VXE6, VXE7, VXG, VXM, VXU, VXU1, VXW, VXW1, VXW2, VX2, VX26, VX4, WDA6, WJP, WKD6, WKT2, WKT4, WKT6, WME2	
			-	(1)	1	-		



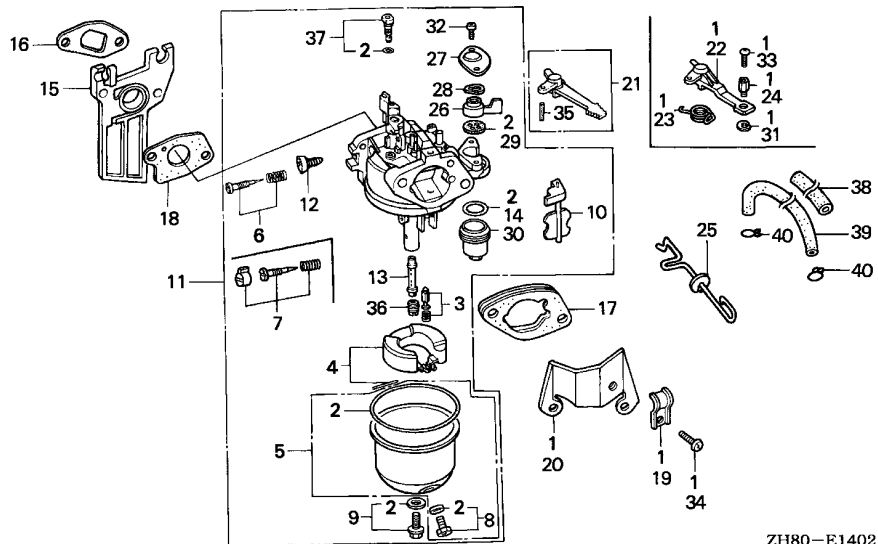

ZH80-E1402



2

Ref. No.	Part No.	Description	Reqd. QTY				Serial No.	Parts catalogue code
			(1)	(2)	(3)	(4)		
10	16044-ZE0-005	CHOKE SET	1	-	-	-	-----	BL, HG12, HHQ4, HH26, HXE, HXE2, HXE8, HXQ, HXU, HX2, HX26, HX4, LAX2, LHB3, LHQ4, LHW, LJC7, LJD, LJG, LSJ, LSS, LSS1, LVL, LXU, LX2, LX26, LX4, NJ, NJG, NSJ, NW, PHM, PHU, PXU, PX2, QAB1, QAB3, QAX, QAX2, QA2, QA26, QBC2, QBT2, QBT6, QBU2, QCB2, QCL, QGR2, QGR9, QHP1, QHQ4, QH26, QI2, QKA4, QMC8, QMD6, QME4, QMH, QMX2, QMZ2, QNT2, QP, QPU, QSC2, QSC9, QS2, QVL, QWA4, QWM2, QWX2, QWX3, QXB1, QXC6, QXC9, QXE2, QXE4, QXE6, QXE8, QXF2, QXM1, QXQ, QXS2, QXU, QXW2, QX2, QX22, QX26, QX4, QX7, REX4, RFR2, RHA2, RHQ4, RH2, RH26, RMB4, RMG2, RNG, RSS1, RTB2, RXE2, RXE4, RXU, RX4, SAD2, SDN, SDS2, SDS3, SG24, SHM, SHQ4, SHRY, SHR4, SJC, SJC1, SJC5, SJG, SMB4, SMC7, SMC9, SMW2, SMX4, SM11, SM12, SM14, SNX, SNX1, SSK1, SSK2, SSS2, STM, SWG4, SWX2, SWX4, SXE4, SXS4, SXU, SX4, SX7, S1CY, TCS2, THU, TXC9, TXU, TX2, TX26, TX4, UXU, VA2, VEB2, VED5, VED6, VGE4, VG24, VHA7, VHH4, VHQ4, VMB3, VMS4, VMS7, VSD7, VSX3, VTD, VTD1, VTU1, VWA2, VW12, VXD, VXD1, VXE4, VXE6, VXE7, VXG, VXM, VXU, VXU1, VXXW1, VXXW2, VX2, VX26, VX4, WDA6, WJP, WKD6, WKT2, WKT4, WKT6, WME2
		(CARBURETOR NO.)	1	-	-	-	BE06J B -----	DS, DSP, EN, ET, ETX, HG1, HH, HX, KTA, LAX, LH, LJ, LJS, LMT, LTK, LX, PH, PX, QA, QH, QHE, QNT, QT, QX, QXB, QXE, QXF, QXS, QXW, RAC, RFR, RH, RHA, RMD, RSK, RX, RXE, SAC, SCJ, SH, SJ, SMJ, SMJ1, STA, STP, STQ, SX, SXB, SXE, TH, TX, UH, UX, VA, VED, VED1, VH, VS, VSD, VSX, VSX1, VS1, VWA, VX, VXE, VXX
		//	1	-	-	-	BE06R A -----	ST
		//	1	-	-	-	BE65C B -----	QXC
		//	-	(1)	-	-	BE06J B	
		//	-	-	1	-		
	16044-ZF1-901	1	-	-	-	-----	QZ
	16044-ZK8-V00	1	-	-	-	-----	AR
11	16100-ZH8-T50	CARBURETOR ASSY. (BE06U A) ..	1	-	-	-	-----	4007365 PHU, THU

E-14-2

CARBURETOR(3)

L10

Ref. No.	Part No.	Description	Reqd. QTY				Serial No.	Parts catalogue code
			GX160K1 (1)	(2)	(3)	(4)		
11)	16100-ZH8-V00	CARBURETOR ASSY. (BE06R A)	..	1	-	-	4023626 STM	
				1	-	-	4023626 ST	
	16100-ZH8-V10	CARBURETOR ASSY. (BE07C A)	..	1	-	-	4153280 SKM	
	16100-ZH8-V20	CARBURETOR ASSY. (BE65G A)	..	1	-	-	4012990 QSC2,QXC6,QXC9,TXC9	
	16100-ZH8-W01	CARBURETOR ASSY. (BE65A A)	..	1	-	-	4007365 HXQ,QXQ	
	16100-ZH8-W40	CARBURETOR ASSY. (BE66D A)	..	1	-	-	4051511 VEB2,VG24	
	16100-ZH8-W50	CARBURETOR ASSY. (BE65B A)	..	1	-	-	4011427 HG12,HH26,HX2,HX26,LAX2,LX2,LX26,PX2,QAX2,QBT2,QBT6,QBU2,QGR2 QH26,QMX2,QMZ2,QNT2,QXE2,QXE6,QXF2,QXS2,QXW2,QX2,QX26,RFR2 RHA2,RH2,RH26,RMG2,RTB2,SAD2,SG24,SMW2,SSK2,SSX2,TX2,TX26,VA2 VWA2,VW12,VXW2,VX2,VX26	
	16100-ZH8-W60	CARBURETOR ASSY. (BE65C A)	..	1	-	-	4017073 QA2,QA26,WKT2,WME2	
	16100-ZH8-800	CARBURETOR ASSY. (BE11C A)	..	1	-	-	4047733 QXC	
	16100-ZH8-801	CARBURETOR ASSY. (BE11C B)	..	1	-	-	4047734 6276049 QXC	
	16100-ZH8-820	CARBURETOR ASSY. (BE06J A)	..	1	-	-	2369780 ST	
				1	-	-	2895090 DS,DSP,EN,ET,ETX,HG1,HH,HX,KTA,LAX,LH,LJ,LJS,LMT,LTk,LX,PH,PX QA,QH,QHE,QNT,QT,QX,QXB,QXE,QXF,QXS,QXW,RAC,RFR,RH,RHA,RMD,RSK RX,RXE,SAC,SCJ,SH,SJ,SMJ,SMJ1,STA,STP,STQ,STX,STY,TH,TX,UH UX,VA,VED,VED1,VH,VS,VSD,VSX,VSX1,VS1,VWA,VX,VXE,VXW	
	16100-ZH8-900	CARBURETOR ASSY. (BE06S A)	..	-	(1)	-	2895090	
	16100-ZK8-V01	CARBURETOR ASSY. (BE67B B)	..	1	-	-	4383862 QZ	
	16100-ZH8-T51	CARBURETOR ASSY. (BE06U B)	..	1	-	-	5206051 AR	
				1	-	-	4007366 THU	
				1	-	-	4007366 PHU	
	16100-ZH8-V01	CARBURETOR ASSY. (BE06R B)	..	1	-	-	4023627 ST,STM	
	16100-ZH8-V11	CARBURETOR ASSY. (BE07C B)	..	1	-	-	4153281 SKM	
	16100-ZH8-V21	CARBURETOR ASSY. (BE65G B)	..	1	-	-	QSC9	
				1	-	-	4012991 QSC2,QXC6,QXC9,TXC9	
				1	-	-	6276050 QXC	
	16100-ZH8-821	CARBURETOR ASSY. (BE06J B)	..	1	(1)	-	2895091 4012551 DS,DSP,EN,ET,ETX,HG1,HH,HX,KTA,LAX,LH,LJ,LJS,LMT,LTk,LX,PH,PX QA,QH,QHE,QNT,QT,QX,QXB,QXE,QXF,QXS,QXW,Q1,RAC,RFR,RH,RHA,RMD RSK,RX,RXE,R1,SAC,SCJ,SH,SJ,SMJ,SMJ1,STA,STP,STQ,STX,STY,TH,TX,UH UX,VA,VED,VED1,VH,VS,VSD,VSX,VSX1,VS1,VWA,VX,VXE,VXW VXW,V1,W1	
				1	-	-	4012551 HHQ4,HXE,HX4,LHB3,LHQ4,LJD,LJG,LSS,LSS1,LX4,NJ,NJG,QAB1,QAB3 QAX,QHQ4,QKA4,QMC8,QMD6,QME4,QP,QPU,QXB1,QXE4,QX4,RHQ4,RMB4 RNG,RXE4,RX4,SDS2,SDS3,SHQ4,SJC,SJG,SMB4,SMC7,SMC9,SNX,SSK1 SWG4,SXE4,SX4,TX4,VED5,VGE4,VHH4,VHQ4,VMB3,VMS4,VXD,VXD1,VXE4 VXG,VXU,VXW1,VX4,WJP	
				-	(1)	-	2895091 H1,L1,U1	
				-	-	1	UIH	
	16100-ZH8-822	CARBURETOR ASSY. (BE06J C)	..	1	(1)	-	4012552 EN,ET,ETX,HG1,LAX,LJD,LJS,LMT,LSS1,LTk,QAX,QKA4,QME4,QT,QXB QXF,QXS,Q1,RAC,RFR,RHA,RMB4,RMD,R1,SAC,SDS3,SMB4,SMJ,SNX,STA SWG4,SXB,S1,T1,VA,VGE4,VH,VHQ4,VSX,VSX1,VS1,VWA,VX,VXU,VXW VXW1,V1,W1	
				1	-	1	LHW,QIH1,QXM1,REX4,SDN,SM11,SNX1,UIH,VTU1,WIH1	
				1	-	-	6276049 HXE8,HXU,LJC7,LSJ,LXU,NSJ,NW,PHM,PXU,QHP1,QMH,QXE8,QXU,RSS1 RXU,SHM,SHRY,SHR4,SJC1,SJC5,SM14,SXU,S1CY,TXU,UXU,VSX3,VTD VTD1,VXM,VXU1	
				1	-	-	4012552 6276049 DS,DSP,HH,HHQ4,HX,HXE,HX4,KTA,LH,LHB3,LHQ4,LJ,LJG,LSS,LX,LX4 NJ,NJG,PH,PX,QA,QAB1,QAB3,QH,QHE,QHQ4,QMC8,QMD6,QNT,QP,QPU,QX QXB1,QXE,QXE4,QXW,QX4,RH,RHQ4,RNG,RSK,RX,RXE,RXE4,RX4,SCJ,SDS2 SH,SHQ4,SJ,SJC,SJG,SMC7,SMC9,SMJ1,SSK1,STP,STQ,STX,STY,TH,TX,UX UXU,VED1,VED5,VHH4,VMB3,VMS4,VS,VSD,VX,VXD VXD1,VXE4,VXG,VX4,WJP	
	16100-ZH8-901	CARBURETOR ASSY. (BE06S B)	..	1	-	-	4383863 QZ	
	16100-ZK8-T51	CARBURETOR ASSY. (BE67C A)	..	1	-	-	5206052 AR	
	16100-ZH8-W02	CARBURETOR ASSY. (BE65A B)	..	1	-	-	4007366 HXQ,QXQ	

2

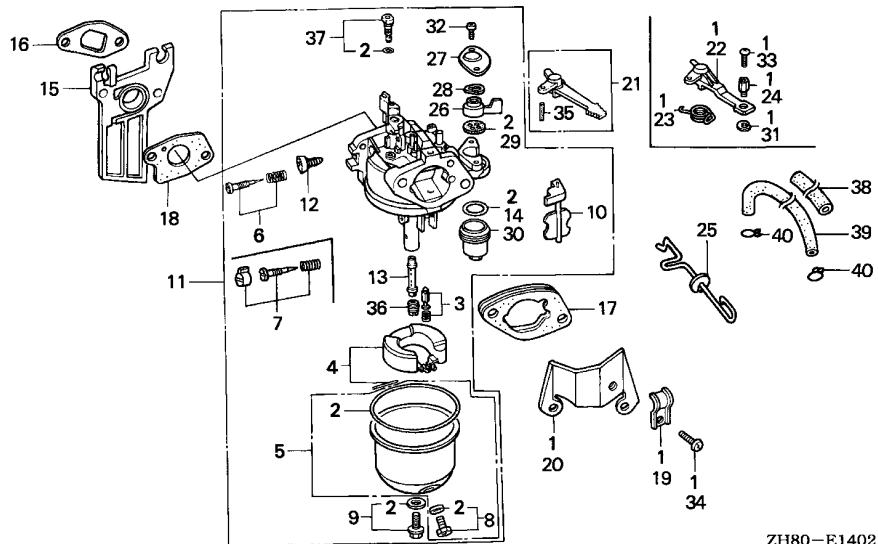

ZH80-E1402



Ref. No.	Part No.	Description	Reqd. QTY				Serial No.	Parts catalogue code
			(1)	(2)	(3)	(4)		
11)	16100-ZH8-W41	CARBURETOR ASSY. (BE66D B) ..	1	-	-	-	4051512 -----	VEB2,VG24
	16100-ZH8-W51	CARBURETOR ASSY. (BE65B B) ..	1	-	-	-	6276050 -----	PHU HXE2,QBC2,QCB2,QCL,QGR9,QI2,QS2,QWA4,QWM2,QWX2,QWX3,QX22,QX7 RXE2,SMX4,SM12,SWX2,SWX4,SXS4,SX7,TCS2,VHA7,VIH1,VMS7,VSD7 VXE6,VXE7,WDA6
			1	-	-	-	4011428 -----	HG12,HH26,HX2,HX26,LAX2,LX2,LX26,PX2,QAX2,QBT2,QBT6,QBU2,QGR2 QH26,QMX2,QMZ2,QNT2,QXE2,QXE6,QXF2,QXS2,QXW2,QX2,QX26,RFR2 RHA2,RH2,RH26,RMG2,RTB2,SAD2,SG24,SMW2,SSK2,SSX2,TX2,TX26,VA2 VWA2,VW12,VXW2,VX2,VX26
	16100-ZH8-W61	CARBURETOR ASSY. (BE65C B) ..	1	-	-	-	6276050 -----	HH,HHQ4,HX,HXE,HXE8,HXU,HX4,KTA,LH,LHB3,LHQ4,LSJ,LX,LXU,LX4,NW PH,PHM,PX,PXU,QH,QHE,QHP1,QHQ4,QMC8,QMD6,QMH,QNT,QP,QPU,QX QXB1,QXE,QXE4,QXE8,QXU,QXW,QX4,RH,RHQ4,RSK,RX,RXE,RXE4,RXU,RX4 SH,SHM,SHQ4,SMC7,SMC9,SMJ1,SM14,SSK1,STP,STQ,SX,SXE,SXE4,SXU SX4,S1CY,TH,TX,TXU,TX4,UH,UX,UXU,VHH4,VMB3,VMS4,VS,VSD,VSX3 VTD,VTD1,VX,VXE4,VXG,VXM,VXU1,VX4 VED6,WKD6,WKT4,WKT6
			1	-	-	-	4017074 -----	QA2,QA26,WKT2,WME2
			1	-	-	-	6276050 -----	DS,DSP,LJ,LJC7,LJG,LSS,NJ,NJG,NSJ,QA,QAB1,QAB3,RNG,RSS1,SCJ SDS2,SHRY,SHR4,SJ,SJC,SJC1,SJC5,SJG,VED,VED1,VED5,VXD,VXD1,WJP BL,LVL,QVL
	16100-ZK8-W81	CARBURETOR ASSY. (BE65M A) ..	1	-	-	-	-----	

Ref. No.	Part No.	Description	Reqd. QTY				Serial No.	Parts catalogue code
			(1)	(2)	(3)	(4)		
12	16124-ZE0-005	SCREW, THROTTLE STOP	1	-	-	-	AR, BL, DS, DSP, EN, ET, ETX, HG1, HG12, HH, HHQ4, HH26, HX, HXE, HXE2, HXE8, HXQ, HXU, HX2, HX26, HX4, KTA, LAX, LAX2, LH, LHB3, LHQ4, LHW, LJ, LJ C7, LJD, LJG, LJS, LMT, LSJ, LSS, LSS1, LTK, LVL, LX, LXU, LX2, LX26, LX4, NJ, NJG, NSJ, NW, PH, PHM, PHU, PX, PXU, PX2, QA, QAB1, QAB3, QAX, QAX2, QA2, QA26, QBC2, QBT2, QBT6, QBU2, QCB2, QCL, QGR2, QGR9, QH, QHE, QHP1, QHQ4, QH26, QI2, QKA4, QMC8, QMD6, QME4, QMH, QMX2, QMZ2, QNT, QNT2, QP, QPU, QSC2, QSC9, QS2, QT, QVL, QWA4, QWM2, QWX2, QWX3, QX, QXB, QXB1, QXC, QXC6, QXC9, QXE, QXE2, QXE4, QXE6, QXE8, QXF, QXF2, QXM1, QXQ, QXS, QXS2, QXU, QXW, QXW2, QX2, QX22, QX26, QX4, QX7, QZ, RAC, REX4, RFR, RFR2, RH, RHA, RHA2, RHQ4, RH2, RH26, RMB4, RMD, RMG2, RNG, RSK, RSS1, RTB2, RX, RXE, RXE2, RXE4, RXU, RX4, SAC, SAD2, SCJ, SDN, SDS2, SDS3, SG24, SH, SHM, SHQ4, SHRY, SHR4, SJ, SJC, SJC1, SJC5, SJG, SKM, SMB4, SMC7, SMC9, SMJ, SMJ1, SMW2, SMX4, SM11, SM12, SM14, SNX, SNX1, SSK1, SSK2, SSS2, ST, STA, STM, STP, STQ, SWG4, SWX2, SWX4, SX, SXB, SXE, SXE4, SXS4, SXU, SX4, SX7, S1CY, TCS2, TH, THU, TX, TXC9, TXU, TX2, TX26, TX4, UH, UX, UXU, VA, VA2, VEB2, VED, VED1, VED5, VED6, VGE4, VG24, VH, VHA7, VHH4, VHQ4, VMB3, VMS4, VMS7, VS, VSD, VSD7, VSX, VSX1, VSX3, VS1, VTD, VTD1, VTU1, VWA, VWA2, VW12, VX, VXD, VXD1, VXE, VXE4, VXE6, VXE7, VXG, VXM, VXU, VXU1, VXW, VXW1, VXW2, VX2, VX26, VX4, WDA6, WJP, WKD6, WKT2, WKT4, WKT6, WME2	
13	16166-ZH8-800	NOZZLE, MAIN	-	(1)	1	-		
		(CARBURETOR NO.)	1	-	-	-	BE11C B QXC	
	16166-ZH8-810	1	-	-	-	ST, STM	
		(CARBURETOR NO.)	1	-	-	-	BE06J A DS, DSP, EN, ET, ETX, HG1, HH, HX, KTA, LAX, LH, LJ, LJS, LMT, LTK, LX, PH, PX, QA, QH, QHE, QNT, QT, QX, QXB, QXE, QXF, QXS, QXW, RAC, RFR, RH, RHA, RMD, RSK, RX, RXE, SAC, SCJ, SH, SJ, SMJ, SMJ1, STA, STP, STQ, SX, SXB, SXE, TH, TX, UH, UX, VA, VED, VED1, VH, VS, VSD, VSX, VSX1, VS1, VWA, VX, VXE, VXW	
	16166-ZF1-005	///	-	(1)	-	-	BE06J A	
	16166-ZH8-W00	1	-	-	-	QZ, SKM	
		(CARBURETOR NO.)	1	-	-	-	HXQ, QSC2, QSC9, QXC6, QXC9, QXQ, TXC9	
	16166-ZH8-W50	1	-	-	-	BE65G B QXC	
		(CARBURETOR NO.)	1	-	-	-	HG12, HHQ4, HH26, HXE, HXE2, HXE8, HXU, HX2, HX26, HX4, LAX2, LHB3, LHQ4, LHW, LJD, LSJ, LSS1, LXU, LX2, LX26, LX4, NW, PHM, PHU, PXU, PX2, QAB1, QAB3, QAX, QAX2, QBC2, QBT2, QBT6, QBU2, QCB2, QCL, QGR2, QGR9, QHP1, QHQ4, QH26, QI2, QKA4, QMC8, QMD6, QME4, QMH, QMX2, QMZ2, QNT2, QP, QPU, QS2, QWA4, QWM2, QWX2, QWX3, QXB1, QXE2, QXE4, QXE6, QXE8, QXF2, QXM1, QXS2, QXU, QXW2, QX2, QX22, QX26, QX4, QX7, REX4, RFR2, RHA2, RHQ4, RH2, RH26, RMB4, RMG2, RTB2, RXE2, RXE4, RXU, RX4, SAD2, SDN, SDS2, SDS3, SG24, SHM, SHQ4, SMB4, SMC7, SMC9, SMW2, SMX4, SM11, SM12, SM14, SNX, SNX1, SSK1, SSK2, SSS2, SWG4, SWX2, SWX4, SXE4, SXS4, SXU, SX4, SX7, S1CY, TCS2, THU, TXU, TX2, TX26, TX4, UXU, VA2, VEB2, VGE4, VG24, VHA7, VHH4, VHQ4, VMB3, VMS4, VMS7, VSD7, VSX3, VTD, VTD1, VTU1, VWA2, VW12, VXE4, VXE6, VXE7, VXG, VXM, VXU, VXU1, VXW1, VXW2, VX2, VX26, VX4, WDA6	
		(CARBURETOR NO.)	1	-	-	-	BE06J B EN, ET, ETX, HG1, HH, HX, KTA, LAX, LH, LJS, LMT, LTK, LX, PH, PX, QH, QHE, QNT, QT, QX, QXB, QXE, QXF, QXS, QXW, RAC, RFR, RH, RHA, RMD, RSK, RX, RXE, SAC, SH, SMJ, SMJ1, STA, STP, STQ, SX, SXB, SXE, TH, TX, UH, UX, VA, VED, VED1, VH, VS, VSD, VSX, VSX1, VS1, VWA, VX, VXE, VXW	
		///	1	-	-	-	BE06J C LJ C7, LJG, LSS, NJ, NJG, NSJ, RNG, RSS1, SHRY, SHR4, SJC, SJC1, SJC5, SJG, VED5, VXD, VXD1, WJP	
		///	-	(1)	-	-	BE06J B BE06J C DS, DSP, LJ, QA, SCJ, SJ	
		///	-	-	1	-		
	16166-ZH8-W60	1	-	-	-	BE65C B BL, LVL, QA2, QA26, QVL, VED6, WKD6, WKT2, WKT4, WKT6, WME2	
		(CARBURETOR NO.)	1	-	-	-	DS, DSP, LJ, LJ C7, LJG, LSS, NJ, NJG, NSJ, QA, RNG, RSS1, SCJ, SHRY, SHR4, SJ, SJC, SJC1, SJC5, SJG, VED5, VXD, VXD1, WJP	
	16166-ZK8-V01	1	-	-	-	AR	



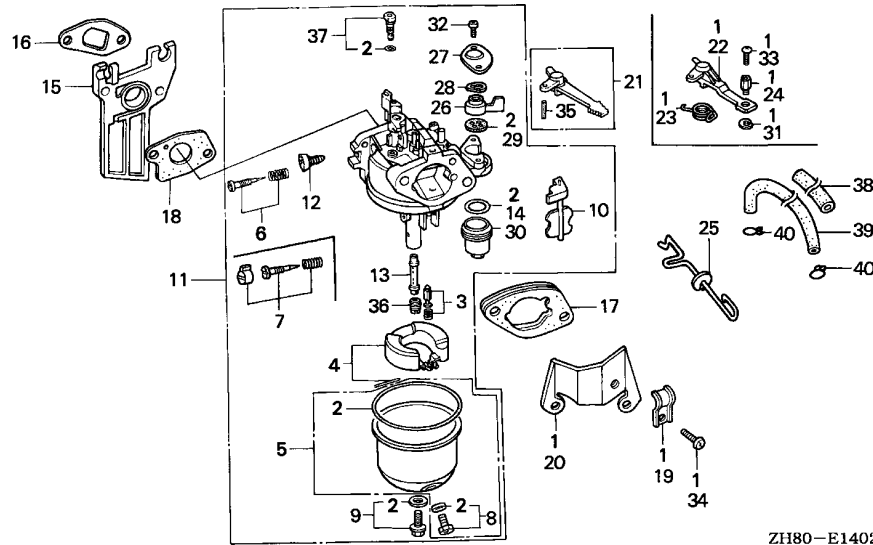

ZH80-E1402



2

Ref. No.	Part No.	Description	Reqd. QTY				Serial No.	Parts catalogue code
			(1)	(2)	(3)	(4)		
				GX160K1				
14	16173-001-004	PACKING, FUEL STRAINER CUP ..	1	-	-	-	-----	BL,DS,DSP,EN,ET,ETX,HG1,HG12,HH,HHQ4,HH26,HX,HXE,HXE2,HXE8,HXQ HXU,HX2,HX26,HX4,KTA,LAX,LAX2,LH,LHB3,LHQ4,LHW,LJ,LJC7,LJD,LJG LJS,LMT,LSJ,LSS,LSS1,LTK,LVL,LX,LXU,LX2,LX26,LX4,NJ,NJG,NSJ,NW PH,PHM,PX,PXU,PX2,QA,QAB1,QAB3,QAX,QAX2,QA2,QA26,QBC2,QBT2 QBT6,QBU2,QCB2,QCL,QGR2,QGR9,QH,QHE,QHP1,QHQ4,QH26,QI2,QKA4 QMC8,QMD6,QME4,QMH,QMX2,QMZ2,QNT,QNT2,QP,QPU,QSC2,QSC9,QS2,QT QVL,QWA4,QWM2,QWX2,QWX3,QX,QXB,QXB1,QXC,QXC6,QXC9,QXE,QXE2 QXE4,QXE6,QXE8,QXF,QXF2,QXM1,QXQ,QXS,QXS2,QXU,QXW,QXW2,QX2 QX22,QX26,QX4,QX7,QZ,RAC,REX4,RFR,RFR2,RH,RHA,RHA2,RHQ4,RH2 RH26,RMB4,RMD,RMG2,RNG,RSK,RSS1,RTB2,RX,RXE,RXE2,RXE4,RXU,RX4 SAC,SAD2,SCJ,SDN,SDS2,SDS3,SG24,SH,SHM,SHQ4,SHRY,SHR4,SJ,SJC SJC1,SJC5,SJG,SKM,SMB4,SMC7,SMC9,SMJ,SMJ1,SMW2,SMX4,SM11,SM12 SM14,SNX,SNX1,SSK1,SSK2,SSX2,ST,STA,STM,STP,STQ,SWG4,SWX2,SWX4 SX,SXB,SXE,SXE4,SXS4,SXU,SX4,SX7,S1CY,TCS2,TH,TX,TCX9,TXU,TX2 TX26,TX4,UH,UX,UXU,VA,VA2,VED,VED1,VED5,VED6,VGE4,VH,VHA7,VHH4 VHQ4,VMB3,VMS4,VMS7,VS,VSD,VSD7,VSX,VSX1,VSX3,VS1,VTD,VTD1 VTU1,VVA,VVA2,VW12,VX,VXD,VXD1,VXE,VXE4,VXE6,VXE7,VXG,VXM,VXU VXU1,VXW,VXW1,VXW2,VX2,VX26,VX4,WDA6,WJP,WKD6,WKT2,WKT4,WKT6 WME2
			-	(1)	1	-		

Ref. No.	Part No.	Description	Reqd. QTY				Serial No.	Parts catalogue code
			(1)	(2)	(3)	(4)		
15	16211-ZE1-000	INSULATOR, CARBURETOR	1	-	-	-	-----	AR, BL, DS, DSP, EN, ET, ETX, HG1, HG12, HH, HHQ4, HH26, HX, HXE, HXE2, HXE8, HXQ, HXU, HX2, HX26, HX4, KTA, LAX, LAX2, LH, LHB3, LHQ4, LHW, LJ, LJC7, LJD, LJG, LJS, LMT, LSJ, LSS, LSS1, LTK, LVL, LX, LXU, LX2, LX26, LX4, NJ, NJG, NSJ, NW, PH, PHM, PHU, PX, PXU, PX2, QA, QAB1, QAB3, QAX, QAX2, QA2, QA26, QBC2, QBT2, QBT6, QBU2, QCB2, QCL, QGR2, QGR9, QH, QHE, QHP1, QHQ4, QH26, QI2, QKA4, QMC8, QMD6, QME4, QMH, QMX2, QMZ2, QNT, QNT2, QP, QPU, QSC2, QSC9, QS2, QT, QVL, QWA4, QWM2, QWX2, QWX3, QX, QXB, QXB1, QXC, QXC6, QXC9, QXE, QXE2, QXE4, QXE6, QXE8, QXF, QXF2, QXM1, QXQ, QXS, QXS2, QXU, QXW, QXW2, QX2, QX22, QX26, QX4, QX7, QZ, RAC, REX4, RFR, RFR2, RH, RHA, RHA2, RHQ4, RH2, RH26, RMB4, RMD, RMG2, RNG, RSK, RSS1, RTB2, RX, RXE, RXE2, RXE4, RXU, RX4, SAC, SAD2, SCJ, SDN, SDS2, SDS3, SG24, SH, SHM, SHQ4, SHRY, SHR4, SJ, SJC, SJC1, SJC5, SJG, SKM, SMB4, SMC7, SMC9, SMJ, SMJ1, SMW2, SMX4, SM11, SM12, SM14, SNX, SNX1, SSK1, SSK2, SSS2, ST, STA, STM, STP, STQ, SWG4, SWX2, SWX4, SX, SXB, SXE, SXE4, SXS4, SXU, SX4, SX7, S1CY, TCS2, TH, THU, TX, TXC9, TXU, TX2, TX26, TX4, UH, UX, UXU, VA, VA2, VEB2, VED, VED1, VED5, VED6, VGE4, VG24, VH, VHA7, VHH4, VHQ4, VMB3, VMS4, VMS7, VS, VSD, VSD7, VSX, VSX1, VSX3, VS1, VTD, VTD1, VTU1, VWA, VWA2, VW12, VX, VXD, VXD1, VXE, VXE4, VXE6, VXE7, VXG, VXM, VXU, VXU1, VXW, VXW1, VXW2, VX2, VX26, VX4, WDA6, WJP, WKD6, WKT2, WKT4, WKT6, WME2
			-	1	1	-		
16	16212-ZH8-000	PACKING, INSULATOR	1	-	-	-	----- 2630823	DS, DSP, EN, ET, ETX, KTA, LJ, LJS, LMT, LTK, QT, QZ, SCJ, SJ, SKM, SMJ, SMJ1, ST, STA, STP, STQ
	16212-ZH8-800	-	(1)	-	-	----- 2630823	AR, BL, HG1, HG12, HH, HHQ4, HH26, HX, HXE, HXE2, HXE8, HXQ, HXU, HX2, HX26, HX4, LAX, LAX2, LH, LHB3, LHQ4, LHW, LJC7, LJD, LJG, LSJ, LSS, LSS1, LVL, LX, LXU, LX2, LX26, LX4, NJ, NJG, NSJ, NW, PH, PHM, PHU, PX, PXU, PX2, QA, QAB1, QAB3, QAX, QAX2, QA2, QA26, QBC2, QBT2, QBT6, QBU2, QCB2, QCL, QGR2, QGR9, QH, QHE, QHP1, QHQ4, QH26, QI2, QKA4, QMC8, QMD6, QME4, QMH, QMX2, QMZ2, QNT, QNT2, QP, QPU, QSC2, QSC9, QS2, QVL, QWA4, QWM2, QWX2, QWX3, QX, QXB, QXB1, QXC, QXC6, QXC9, QXE, QXE2, QXE4, QXE6, QXE8, QXF, QXF2, QXM1, QXQ, QXS, QXS2, QXU, QXW, QXW2, QX2, QX22, QX26, QX4, QX7, RAC, REX4, RFR, RFR2, RH, RHA, RHA2, RHQ4, RH2, RH26, RMB4, RMD, RMG2, RNG, RSK, RSS1, RTB2, RX, RXE, RXE2, RXE4, RXU, RX4, SAC, SAD2, SDN, SDS2, SDS3, SG24, SH, SHM, SHQ4, SHRY, SHR4, SJC, SJC1, SJC5, SJG, SMB4, SMC7, SMC9, SMW2, SMX4, SM11, SM12, SM14, SNX, SNX1, SSK1, SSK2, SSS2, STM, SWG4, SWX2, SWX4, SX, SXB, SXE, SXE4, SXS4, SXU, SX4, SX7, S1CY, TCS2, TH, THU, TX, TXC9, TXU, TX2, TX26, TX4, UH, UX, UXU, VA, VA2, VEB2, VED, VED1, VED5, VED6, VGE4, VG24, VH, VHA7, VHH4, VHQ4, VMB3, VMS4, VMS7, VS, VSD, VSD7, VSX, VSX1, VSX3, VS1, VTD, VTD1, VTU1, VWA, VWA2, VW12, VX, VXD, VXD1, VXE, VXE4, VXE6, VXE7, VXG, VXM, VXU, VXU1, VXW, VXW1, VXW2, VX2, VX26, VX4, WDA6, WJP, WKD6, WKT2, WKT4, WKT6, WME2
			1	-	-	-	----- 2630824	DS, DSP, EN, ET, ETX, KTA, LJ, LJS, LMT, LTK, QT, QZ, SCJ, SJ, SKM, SMJ, SMJ1, ST, STA, STP, STQ
			-	(1)	-	-	----- 2630824	
			-	-	1	-		



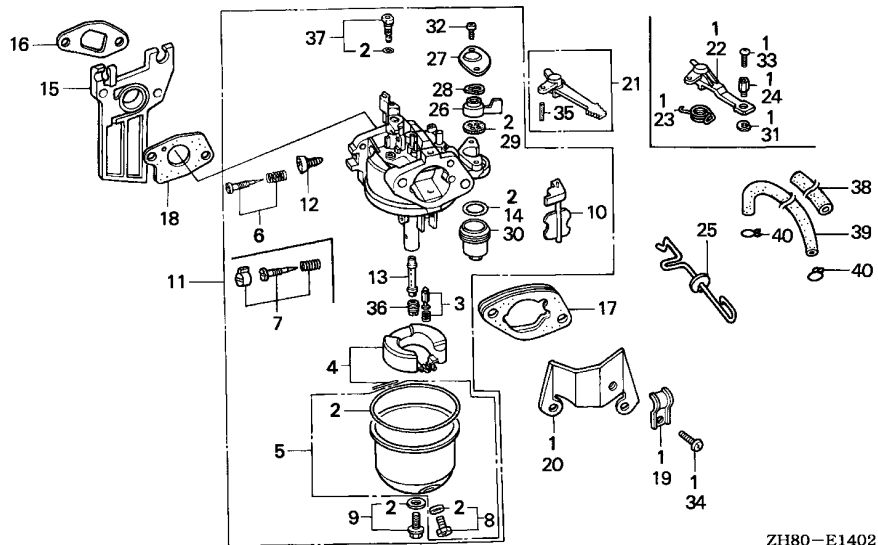

ZH80-E1402



2

Ref. No.	Part No.	Description	Reqd. QTY				Serial No.	Parts catalogue code
			(1)	(2)	(3)	(4)		
			GX160K1					
17	16220-ZE1-020	SPACER COMP., CARBURETOR	1	-	1	-	AR, BL, DS, DSP, EN, ET, ETX, HG1, HG12, HH, HHQ4, HH26, HX, HXE, HXE2, HXE8, HXQ, HXU, HX2, HX26, HX4, KTA, LAX, LAX2, LH, LHB3, LHQ4, LHW, LJ, LJC7, LJD, LJG, LJS, LMT, LSJ, LSS, LSS1, LTK, LVL, LX, LXU, LX2, LX26, LX4, NJ, NJG, NSJ, NW, PH, PHM, PHU, PX, PXU, PX2, QA, QAB1, QAB3, QAX, QAX2, QA2, QA26, QBC2, QBT2, QBT6, QBU2, QCB2, QCL, QGR2, QGR9, QH, QHE, QHP1, QHQ4, QH26, QI2, QKA4, QMC8, QMD6, QME4, QMH, QMX2, QMZ2, QNT, QNT2, QP, QPU, QSC2, QSC9, QS2, QT, QVL, QWA4, QWM2, QWX2, QWX3, QX, QXB, QXB1, QXC, QXC6, QXC9, QXE, QXE2, QXE4, QXE6, QXE8, QXF, QXF2, QXM1, QXQ, QXS, QXS2, QXU, QXW, QXW2, QX2, QX22, QX26, QX4, QX7, RAC, REX4, RFR, RFR2, RH, RHA, RHA2, RHQ4, RH2, RH26, RMB4, RMD, RMG2, RNG, RSK, RSS1, RTB2, RX, RXE, RXE2, RXE4, RXU, RX4, SAC, SAD2, SCJ, SDN, SDS2, SDS3, SG24, SH, SHM, SHQ4, SHRY, SHR4, SJ, SJC, SJC1, SJC5, SJG, SKM, SMB4, SMC7, SMC9, SMJ, SMJ1, SMW2, SMX4, SM11, SM12, SM14, SNX, SNX1, SSK1, SSK2, SSS2, ST, STA, STM, STP, STQ, SWG4, SWX2, SWX4, SX, SXB, SXE, SXE4, SXS4, SXU, SX4, SX7, S1CY, TCS2, TH, THU, TX, TXC9, TXU, TX2, TX26, TX4, UH, UIH, UX, UXU, VA, VA2, VEB2, VED, VED1, VED5, VED6, VGE4, VG24, VH, VHA7, VHH4, VHQ4, VMB3, VMS4, VMS7, VS, VSD, VSD7, VSX, VSX1, VSX3, VS1, VTD, VTD1, VTU1, VWA, VWA2, VW12, VX, VXD, VXD1, VXE, VXE4, VXE6, VXE7, VXG, VXM, VXU, VXU1, VXW, VXW1, VXW2, VX2, VX26, VX4, WDA6, WIH1, WJP, WKD6, WKT2, WKT4, WKT6, WME2	
	16220-ZE1-004	-	1	-	-		
	16269-ZE1-000	PACKING, AIR CLEANER	1	-	-	-	2647626 QZ	
	16269-ZE1-800	1	-	-	-	2647627 QZ	
18	16221-ZE1-000	PACKING, CARBURETOR	1	-	-	-	2630823 DS, DSP, EN, ET, ETX, KTA, LJ, LJS, LMT, LTK, QT, QZ, SCJ, SJ, SKM, SMJ, SMJ1, ST, STA, STP, STQ	
			-	(1)	-	-	2630823	
			-	-	1	-	UIH	

Ref. No.	Part No.	Description	Reqd. QTY				Serial No.	Parts catalogue code	
			GX160K1						
			(1)	(2)	(3)	(4)			
18)	16221-ZH8-800	PACKING, CARBURETOR	1	(1)	-	-	2630824	----- DS,DSP,H1,LJ,LJS,LTk,SCJ,SJ,ST,STP,STQ,U1	
			1	(1)	-	-	2630824	3427128 EN,ET,ETX,KTA,L1,QT,QZ,Q1,R1,STA,S1,T1,V1,W1	
			1	-	1	-	-----	3427128 HH,LAX,LH,LX,PH,PHU,PX,QH,QHE,QNT,QXB,QXW,RAC,RSK,RX,RXE,SAC	
									SH,SX,SXB,SXE,TH,THU,UH,UIH,UX,VA,VED,VED1,VH,VS,VSD,VSX,VSX1
									VS1,VXE,VXG,VXU
									LJD,LJG,RMD,SJG,SSK1
			1	-	-	-	-----	-----	-----
			1	-	-	-	-----	3427588	HXQ,HX2,LX2,PX2,QA2,QGR2,QXE2,QXF2,QXQ,QXS2,QX2,RH2,TX2,VXW2
									VX2
			1	-	-	-	-----	3427858	LSS,SNX,STM,WJP
			1	-	-	-	-----	3429382	HHQ4,HX4,LHQ4,LX4,QHQ4,QXE4,QX4,RHQ4,RXE4,RX4,SHQ4,SXE4,SX4
									TX4,VHQ4,VXE4,VX4
			1	-	-	-	-----	3430748	HG1,HX,QA,QAX,QX,QXC,QXE,QXF,QXS,RFR,RH,RHA,TX,VWA,VX,VXW,VXW1
									2630824 3427858 LMT,SKM,SMJ,SMJ1
	16221-ZH8-801	1	(1)	1	-	3427129	----- EN,ET,ETX,HH,KTA,LAX,LH,LX,L1,PH,PHU,PX,QH,QHE,QNT,QNZ,QT,QXB	
								QXW,QZ,Q1,RAC,RSK,RX,RXE,R1,SAC,SH,STA,SX,SXB,SXE,S1,TH,THU,T1	
								UH,UIH,UX,VA,VED,VED1,VH,VS,VSD,VSX,VSX1,VS1,VXE,VXG,VXU,V1,W1	
								AR,BL,HG12,HH26,HXE,HXE2,HXE8,HXU,HX26,LAX2,LHB3,LHW,LJC7,LSJ	
								LSS1,LVL,LXU,LX26,NJ,NJG,NSJ,NW,PHM,PXU,QAB1,QAB3,QAX2,QA26	
								QBC2,QBT2,QBT6,QBU2,QCB2,QCL,QGR9,QHP1,QH26,QIH1,QI2,QKA4,QMC8	
								QMD6,QME4,QMH,QMX2,QMZ2,QNT2,QP,QPU,QSC2,QSC9,QS2,QVL,QWA4	
								QWM2,QWX2,QWX3,QXB1,QXC6,QXC9,QXE6,QXE8,QXM1,QXU,QXW2,QX22	
								QX26,QX7,REX4,RFR2,RHA2,RH26,RMB4,RMG2,RNG,RSS1,RTB2,RXE2,RXU	
								SAD2,SDN,SDS2,SDS3,SG24,SHM,SHRY,SHR4,SJC,SJC1,SJC5,SMB4,SMC7	
								SMC9,SMW2,SMX4,SM11,SM12,SM14,SNX1,SSK2,SSX2,SWG4,SWX2,SWX4	
								SXS4,SXU,SX7,S1CY,TCS2,TCX9,TXU,TX26,UXU,VA2,VEB2,VED5,VED6	
								VGE4,VG24,VHA7,VHH4,VIH1,VMB3,VMS4,VMS7,VSD7,VSX3,VTD,VTD1	
								VTU1,VWA2,VW12,VXD,VXD1,VXE6,VXE7,VXM,VXU1,VX26,WDA6,WIH1,WKD6	
								WKT2,WKT4,WKT6,WME2	
								3427589	----- HXQ,HX2,LX2,PX2,QA2,QGR2,QXE2,QXF2,QXQ,QXS2,QX2,RH2,TX2,VXW2
								VX2	
								3427859	----- LMT,LSS,SKM,SMJ,SMJ1,SNX,STM,WJP
								3429383	----- HHQ4,HX4,LHQ4,LX4,QHQ4,QXE4,QX4,RHQ4,RXE4,RX4,SHQ4,SXE4,SX4
								TX4,VHQ4,VXE4,VX4	
								3430749	----- HG1,HX,QA,QAX,QX,QXC,QXE,QXF,QXS,RFR,RH,RHA,TX,VWA,VX,VXW,VXW1
								-----	HG1,HG12,LHW,LSS1,QSC2,QSC9,QXW,QXW2,STM
								4764119	----- SWG4
								(1)	-----
								-----	HG1,HG12,LHW,LSS1,QSC2,QSC9,QXW,QXW2,STM
								4764119	----- SWG4
								(1)	-----



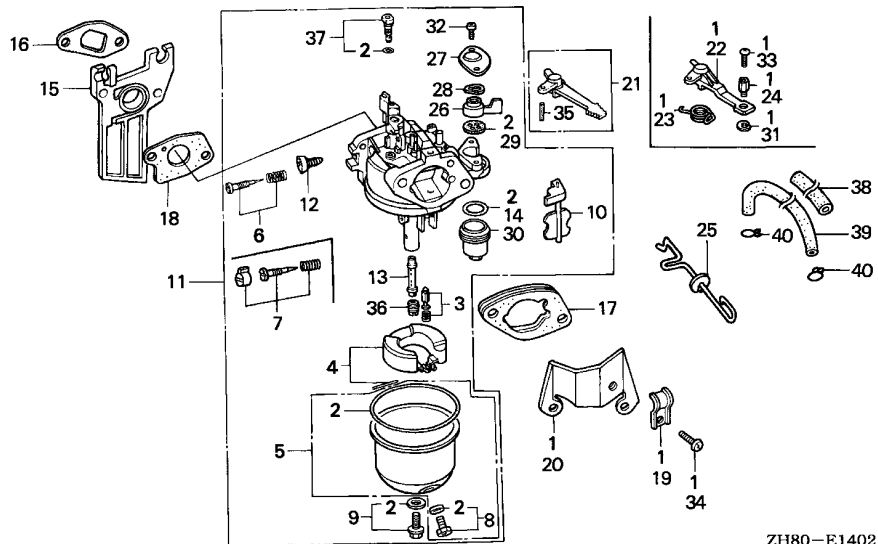

ZH80-E1402



2

Ref. No.	Part No.	Description	Reqd. QTY				Serial No.	Parts catalogue code
			(1)	(2)	(3)	(4)		
21	16610-ZE1-000	LEVER COMP., CHOKE (STD.) ...	1	-	-	-	-----	AR, BL, DS, DSP, EN, ET, ETX, HH, HHQ4, HH26, HX, HXE, HXE2, HXE8, HXQ, HXU, HX2, HX26, HX4, KTA, LAX, LAX2, LH, LHB3, LHQ4, LJ, LJC7, LJD, LJG, LJS, LMT, LSJ, LSS, LTK, LVL, LX, LXU, LX2, LX26, LX4, NJ, NJG, NSJ, NW, PH, PHM, PHU, PX, PXU, PX2, QA, QAB1, QAB3, QAX, QAX2, QA2, QA26, QBC2, QBT2, QBT6, QBU2, QCB2, QCL, QGR2, QGR9, QH, QHE, QHP1, QHQ4, QH26, QI2, QKA4, QMC8, QMD6, QME4, QMH, QMX2, QMZ2, QNT, QNT2, QP, QPU, QS2, QT, QVL, QWA4, QWM2, QWX2, QWX3, QX, QXB, QXB1, QXC, QXC6, QXC9, QXE, QXE2, QXE4, QXE6, QXE8, QXF, QXF2, QXM1, QXQ, QXS, QXS2, QXU, QX2, QX22, QX26, QX4, QX7, RAC, REX4, RFR, RFR2, RH, RHA, RHA2, RHQ4, RH2, RH26, RMB4, RMD, RMG2, RNG, RSK, RSS1, RTB2, RX, RXE, RXE2, RXE4, RXU, RX4, SAC, SAD2, SCJ, SDN, SDS2, SDS3, SG24, SH, SHM, SHQ4, SHRY, SHR4, SJ, SJC, SJC1, SJC5, SJG, SMB4, SMC7, SMC9, SMJ, SMJ1, SMW2, SMX4, SM11, SM12, SM14, SNX, SNX1, SSK1, SSK2, SSS2, STA, STP, STQ, SWX2, SWX4, SX, SXB, SXE, SXE4, SXS4, SXU, SX4, SX7, S1CY, TCS2, TH, THU, TX, TXC9, TXU, TX2, TX26, TX4, UH, UX, UXU, VA, VA2, VEB2, VED, VED1, VED5, VED6, VGE4, VG24, VH, VHA7, VHH4, VHQ4, VMB3, VMS4, VMS7, VS, VSD, VSD7, VSX, VSX1, VSX3, VS1, VTD, VTD1, VTU1, VWA, VWA2, VW12, VX, VXD, VXD1, VXE, VXE4, VXE6, VXE7, VVG, VXM, VXU, VXU1, VWX, VWX1, VWX2, VX2, VX26, VX4, WDA6, WJP, WKD6, WKT2, WKT4, WKT6, WME2
								4764118 SWG4
22	16610-ZE1-810	LEVER COMP., CHOKE (REMOTE) -	1	(1)	1	-	-----	HG1, HG12, LHW, LSS1, QSC2, QSC9, QXW, QXW2, STM
			1	-	-	-	4764119	----- SWG4
23	16615-ZE1-010	SPRING, RETURN	1	(1)	-	-	-----	HG1, HG12, LHW, LSS1, QSC2, QSC9, QXW, QXW2, STM
			1	-	-	-	4764119	----- SWG4
			-	(1)	-	-		

Ref. No.	Part No.	Description	Reqd. QTY				Serial No.	Parts catalogue code
			(1)	(2)	(3)	(4)		
24	16617-890-010	HOLDER, CABLE	1	-	-	-	HG1, HG12, LHW, LSS1, QSC2, QSC9, QXW, QXW2, STM	
			1	-	-	4764119	SWG4	
25	16620-ZF1-900	ROD COMP., THROTTLE	1	(1)	-	-	QZ	
26	16953-ZE1-811	LEVER, COCK	1	(1)	-	-	BE06J B DS, DSP, EN, ET, ETX, HH, HHQ4, HH26, HXE, HX26, HX4, KTA, LAX, LH, LHB3	
		(CARBURETOR NO.)					LHQ4, LJ, LJD, LJG, LJS, LMT, LSS, LSS1, LTK, LX, LX26, LX4, NJ, NJG, PH, PHU	
							PX, QAB1, QAB3, QA26, QBT6, QBU2, QH, QHE, QHQ4, QH26, QKA4, QMC8, QMD6	
							QME4, QNT, QNT2, QP, QPU, QT, QXB, QXB1, QXC6, QXE4, QXE6, QXW, QXW2, QX26	
							QX4, QZ, Q1, RAC, RHQ4, RH26, RMB4, RMD, RNG, RSK, RX, RXE, RXE4, RX4, R1	
							SAC, SAD2, SCJ, SDS2, SDS3, SH, SHQ4, SJ, SJC, SJG, SKM, SMB4, SMC7, SMC9	
							SMJ, SMJ1, SNX, SSK1, ST, STA, STM, STP, STQ, SWG4, SX, SXB, SXE, SXE4, SX4	
							S1, TH, THU, TX26, TX4, T1, UH, UX, VA, VED, VED1, VED5, VGE4, VH, VHH4, VHQ4	
							VMB3, VMS4, VS, VSD, VSX, VSX1, VS1, VXD, VXD1, VXE, VXE4, VXG, VXU, VX26	
							VX4, V1, WJP, W1	
	16953-ZE1-812	-	(1)	1	-	H1, L1, UIH, U1	
		(CARBURETOR NO.)	1	(1)	-	-	BE06J C DS, DSP, EN, ET, ETX, HH, HHQ4, HH26, HXE, HX26, HX4, KTA, LAX, LH, LHB3	
							LHQ4, LJ, LJD, LJG, LJS, LMT, LSS, LSS1, LTK, LX, LX26, LX4, L1, NJ, NJG, PH	
							PHU, PX, QAB1, QAB3, QA26, QBT6, QBU2, QH, QHE, QHQ4, QH26, QKA4, QMC8	
							QMD6, QME4, QNT, QNT2, QP, QPU, QT, QXB, QXB1, QXC6, QXE4, QXE6, QXW, QXW2	
							QX26, QX4, QZ, Q1, RAC, RHQ4, RH26, RMB4, RMD, RNG, RSK, RX, RXE, RXE4, RX4	
							R1, SAC, SAD2, SCJ, SDS2, SDS3, SH, SHQ4, SJ, SJC, SJG, SKM, SMB4, SMC7	
							SMC9, SMJ, SMJ1, SNX, SSK1, ST, STA, STM, STP, STQ, SWG4, SX, SXB, SXE, SXE4	
							SX4, S1, TH, THU, TX26, TX4, T1, UH, UX, VA, VED, VED1, VED5, VGE4, VH, VHH4	
							VHQ4, VMB3, VMS4, VS, VSD, VSX, VSX1, VS1, VXD, VXD1, VXE, VXE4, VXG, VXU	
							VX26, VX4, V1, WJP, W1	
			1	-	1	-	BL, HG1, HG12, HX, HXE2, HXE8, HXQ, HXU, HX2, LAX2, LHW, LJC7, LSJ, LVL, LXU	
							LX2, NSJ, NW, PHM, PXU, PX2, QA, QAX, QAX2, QA2, QBC2, QBT2, QCB2, QCL, QGR2	
							QGR9, QHP1, QIH1, QI2, QMH, QMX2, QMZ2, QSC2, QSC9, QS2, QVL, QWA4, QWM2	
							QWX2, QWX3, QX, QXC, QXC9, QXE, QXE2, QXE8, QXF, QXF2, QXM1, QXQ, QXS, QXS2	
							QXU, QX2, QX22, QX7, REX4, RFR, RFR2, RH, RHA, RHA2, RH2, RMG2, RSS1, RTB2	
							RXE2, RXU, SDN, SG24, SHM, SHRY, SHR4, SJC1, SJC5, SMW2, SMX4, SM11, SM12	
							SM14, SNX1, SSK2, SSX2, SWX2, SWX4, SXS4, SXU, SX7, S1CY, TCS2, TX, TXC9	
							TXU, TX2, UXU, VA2, VEB2, VED6, VG24, VHA7, VIH1, VMS7, VSD7, VSX3, VTD	
							VTD1, VTU1, VWA, VWA2, VW12, VX, VXE6, VXE7, VXM, VXU1, VXW, VXW1, VXW2	
							VX2, WDA6, WIH1, WKD6, WKT2, WKT4, WKT6, WME2	
27	16954-ZE1-811	PLATE, LEVER SETTING	1	-	-	-	BE06J B DS, DSP, LJ, LJD, LJG, LJS, LMT, LSS, LSS1, LTK, NJ, NJG, RMD, RNG, SCJ, SJ	
		(CARBURETOR NO.)					SJC, SJG, SKM, SMJ, SMJ1, SNX, SSK1, ST, STM, STP, STQ, VED5, VXD, VXD1, WJP	
		//	1	-	-	-	BE65B A HG12, HX2, LAX2, LX2, PX2, QAX2, QGR2, QMX2, QMZ2, QXE2, QXF2, QXS2, QX2	
		//	1	-	-	-	RFR2, RHA2, RH2, RMG2, SMW2, SSK2, TX2, VA2, VWA2, VW12, VXW2, VX2	
		//	1	-	-	-	BE65C A QA2, WKT2	
		//	1	-	-	-	BE66D A VEB2	
	16954-ZFO-841	1	-	-	-	BE65A A HXQ, QXQ	
		(CARBURETOR NO.)	1	-	-	-	BE65G A QSC2, QXC6, QXC9, TXC9	
		//						



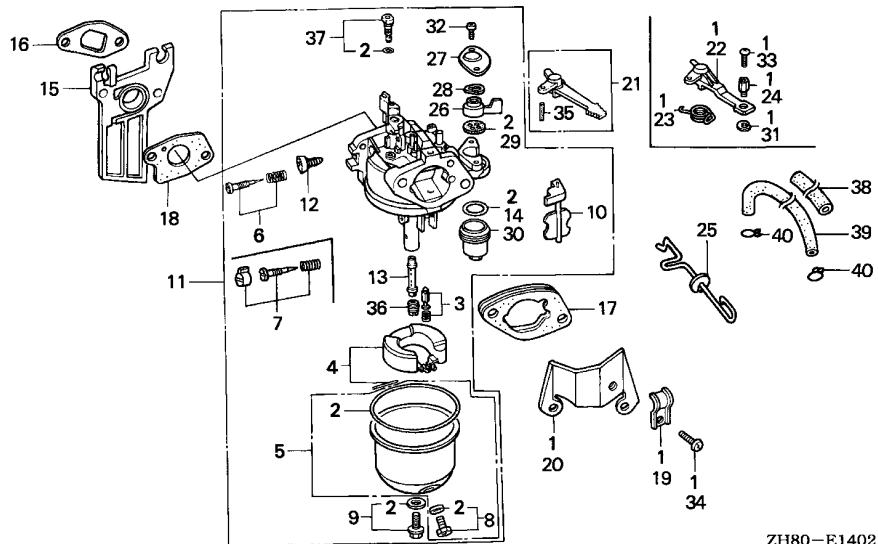

ZH80-E1402



2

Ref. No.	Part No.	Description	Reqd. QTY				Serial No.	Parts catalogue code
			(1)	(2)	(3)	(4)		
			GX160K1					
27)	16954-ZE1-812	PLATE, LEVER SETTING	1	-	1	-	-----	BL,EN,ET,ETX,HG1,HH,HHQ4,HH26,HX,HXE,HXE2,HXE8,HXU,HX26,HX4 KTA,LAX,LH,LHB3,LHQ4,LHW,LJC7,LSJ,LVL,LX,LXU,LX26,LX4,NSJ,NW PH,PHM,PHU,PX,PXU,QA,QAB1,QAB3,QAX,QA26,QBC2,QBT2,QBT6,QBU2 QCB2,QCL,QGR9,QH,QHE,QHP1,QHQ4,QH26,QIH1,QI2,QKA4,QMC8,QMD6 QME4,QMH,QNT,QNT2,QP,QPU,QSC9,QS2,QT,QVL,QWA4,QWM2,QWX2,QWX3 QX,QXB,QXB1,QXC,QXE,QXE4,QXE6,QXE8,QXF,QXM1,QXS,QXU,QXW,QXW2 QX22,QX26,QX4,QX7,QZ,RAC,REX4,RFR,RH,RHA,RHQ4,RH26,RMB4,RSK RSS1,RTB2,RX,RXE,RXE2,RXE4,RXU,RX4,SAC,SAD2,SDN,SDS2,SDS3,SG24 SH,SHM,SHQ4,SHRY,SHR4,SJC1,SJC5,SMB4,SMC7,SMC9,SMX4,SM11,SM12 SM14,SNX1,SSX2,STA,SWG4,SWX2,SWX4,SX,SXB,SXE,SXE4,SXS4,SXU,SX4 SX7,S1CY,TCS2,TH,THU,TX,TXU,TX26,TX4,UH,UX,UXU,VA,VED,VED1 VED6,VGE4,VG24,VH,VHA7,VHH4,VHQ4,VIH1,VMB3,VMS4,VMS7,VS,VSD VSD7,VSX,VSX1,VSX3,VS1,VD,VD1,VTU1,VVA,VX,VXE,VXE4,VXE6,VXE7 VXG,VXM,VXU,VXU1,VXW,VXW1,VX26,VX4,WDA6,WIH1,WKD6,WKT4,WKT6 WME2 DS,DSP,LJ,LJD,LJG,LJS,LMT,LSS,LSS1,LTK,NJ,NJG,RMD,RNG,SCJ,SJ SJC,SJG,SKM,SMJ,SMJ1,SNX,SSK1,ST,STM,STP,STQ,VED5,VXD,VXD1,WJP HXQ,QXQ HG12,HX2,LAX2,LX2,PX2,QAX2,QGR2,QMX2,QMZ2,QXE2,QXF2,QXS2,QX2 RFR2,RHA2,RH2,RMG2,SMW2,SSK2,TX2,VA2,VWA2,VW12,VXW2,VX2 QA2,WKT2 QSC2,QXC6,QXC9,TXC9 VEB2
		(CARBURETOR NO.)	1	-	-	-	BE06J C	
	///		1	-	-	-	BE65A B	
	///		1	-	-	-	BE65B B	
	///		1	-	-	-	BE65C B	
	///		1	-	-	-	BE65G B	
	///		1	-	-	-	BE66D B	
			-	(1)	-	-		

Ref. No.	Part No.	Description	Reqd. QTY				Serial No.	Parts catalogue code
			(1)	(2)	(3)	(4)		
28	16956-ZE1-811	SPRING, COCK LEVER	1	-	-	-	BL,DS,DSP,EN,ET,ETX,HG1,HG12,HH,HHQ4,HH26,HX,HXE,HXE2,HXE8,HXQ HXU,HX2,HX26,HX4,KTA,LAX,LAX2,LH,LHB3,LHQ4,LHW,LJ,LJC7,LJD,LJG LJS,LMT,LSJ,LSS,LSS1,LTK,LVL,LX,LXU,LX2,LX26,LX4,NJ,NJG,NSJ,NW PH,PHM,PHU,PX,PXU,PX2,QA,QAB1,QAB3,QAX,QAX2,QA2,QA26,QBC2,QBT2 QBT6,QBU2,QCB2,QCL,QGR2,QGR9,QH,QHE,QHP1,QHQ4,QH26,QI2,QKA4 QMC8,QMD6,QME4,QMH,QMX2,QMZ2,QNT,QNT2,QP,QPU,QSC2,QSC9,QS2,QT QVL,QWA4,QWM2,QWX2,QWX3,QX,QXB,QXB1,QXC,QXC6,QXC9,QXE,QXE2 QXE4,QXE6,QXE8,QXF,QXF2,QXM1,QXQ,QXS,QXS2,QXU,QXW,QXW2,QX2 QX22,QX26,QX4,QX7,QZ,RAC,REX4,RFR,RFR2,RH,RHA,RHA2,RHQ4,RH2 RH26,RMB4,RMD,RMG2,RNG,RSK,RSS1,RTB2,RX,RXE,RXE2,RXE4,RXU,RX4 SAC,SAD2,SCJ,SDN,SDS2,SDS3,SG24,SH,SHM,SHQ4,SHRY,SHR4,SJ,SJC SJC1,SJC5,SJG,SKM,SMB4,SMC7,SMC9,SMJ,SMJ1,SMW2,SMX4,SM11,SM12 SM14,SNX,SNX1,SSK1,SSK2,SSX2,ST,STA,STM,STP,STQ,SWG4,SWX2,SWX4 SX,SXB,SXE,SXE4,SXS4,SXU,SX4,SX7,S1CY,TCS2,TH,THU,TX,TXC9,TXU TX2,TX26,TX4,UH,UX,UXU,VA,VA2,VEB2,VED,VED1,VED5,VED6,VGE4 VG24,VH,VHA7,VHH4,VHQ4,VMB3,VMS4,VMS7,VS,VSD,VSD7,VSX,VSX1 VSX3,VS1,VTD,VTD1,VTU1,VWA,VWA2,VW12,VX,VXD,VXD1,VXE,VXE4,VXE6 VXE7,VXG,VXM,VXU,VXU1,VXW,VXW1,VXW2,VX2,VX26,VX4,WDA6,WJP,WKD6 WKT2,WKT4,WKT6,WME2	
			-	(1)	1	-		
29	16957-ZE1-812	PACKING, FUEL COCK	1	-	-	-	BL,DS,DSP,EN,ET,ETX,HG1,HG12,HH,HHQ4,HH26,HX,HXE,HXE2,HXE8,HXQ HXU,HX2,HX26,HX4,KTA,LAX,LAX2,LH,LHB3,LHQ4,LHW,LJ,LJC7,LJD,LJG LJS,LMT,LSJ,LSS,LSS1,LTK,LVL,LX,LXU,LX2,LX26,LX4,NJ,NJG,NSJ,NW PH,PHM,PHU,PX,PXU,PX2,QA,QAB1,QAB3,QAX,QAX2,QA2,QA26,QBC2,QBT2 QBT6,QBU2,QCB2,QCL,QGR2,QGR9,QH,QHE,QHP1,QHQ4,QH26,QI2,QKA4 QMC8,QMD6,QME4,QMH,QMX2,QMZ2,QNT,QNT2,QP,QPU,QSC2,QSC9,QS2,QT QVL,QWA4,QWM2,QWX2,QWX3,QX,QXB,QXB1,QXC,QXC6,QXC9,QXE,QXE2 QXE4,QXE6,QXE8,QXF,QXF2,QXM1,QXQ,QXS,QXS2,QXU,QXW,QXW2,QX2 QX22,QX26,QX4,QX7,QZ,RAC,REX4,RFR,RFR2,RH,RHA,RHA2,RHQ4,RH2 RH26,RMB4,RMD,RMG2,RNG,RSK,RSS1,RTB2,RX,RXE,RXE2,RXE4,RXU,RX4 SAC,SAD2,SCJ,SDN,SDS2,SDS3,SG24,SH,SHM,SHQ4,SHRY,SHR4,SJ,SJC SJC1,SJC5,SJG,SKM,SMB4,SMC7,SMC9,SMJ,SMJ1,SMW2,SMX4,SM11,SM12 SM14,SNX,SNX1,SSK1,SSK2,SSX2,ST,STA,STM,STP,STQ,SWG4,SWX2,SWX4 SX,SXB,SXE,SXE4,SXS4,SXU,SX4,SX7,S1CY,TCS2,TH,THU,TX,TXC9,TXU TX2,TX26,TX4,UH,UX,UXU,VA,VA2,VEB2,VED,VED1,VED5,VED6,VGE4 VG24,VH,VHA7,VHH4,VHQ4,VMB3,VMS4,VMS7,VS,VSD,VSD7,VSX,VSX1 VSX3,VS1,VTD,VTD1,VTU1,VWA,VWA2,VW12,VX,VXD,VXD1,VXE,VXE4,VXE6 VXE7,VXG,VXM,VXU,VXU1,VXW,VXW1,VXW2,VX2,VX26,VX4,WDA6,WJP,WKD6 WKT2,WKT4,WKT6,WME2	
			-	(1)	1	-		



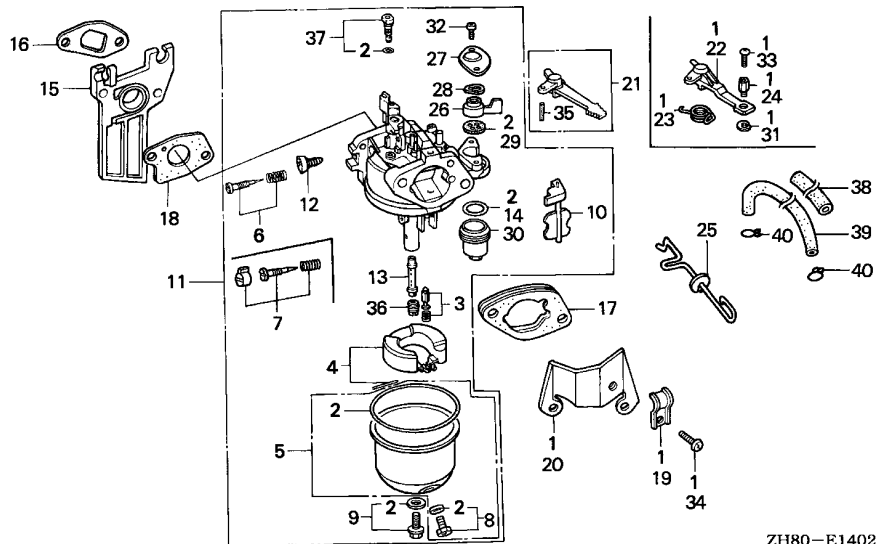

ZH80-E1402



2

Ref. No.	Part No.	Description	Reqd. QTY				Serial No.	Parts catalogue code
			(1)	(2)	(3)	(4)		
30	16967-ZE0-811	CUP, FUEL STRAINER	1	-	-	-	-----	BL,DS,DSP,EN,ET,ETX,HG1,HG12,HH,HHQ4,HH26,HX,HXE,HXE2,HXE8,HXQ HXU,HX2,HX26,HX4,KTA,LAX,LAX2,LH,LHB3,LHQ4,LHW,LJ,LJC7,LJD,LJG LJS,LMT,LSJ,LSS,LSS1,LTK,LVL,LX,LXU,LX2,LX26,LX4,NJ,NJG,NSJ,NW PH,PHM,PX,PXU,PX2,QA,QAB1,QAB3,QAX,QAX2,QA2,QA26,QBC2,QBT2 QBT6,QBU2,QCB2,QCL,QGR2,QGR9,QH,QHE,QHP1,QHQ4,QH26,QI2,QKA4 QMC8,QMD6,QME4,QMH,QMX2,QMZ2,QNT,QNT2,QP,QPU,QSC2,QSC9,QS2,QT QVL,QWA4,QWM2,QWX2,QWX3,QX,QXB,QXB1,QXC,QXC6,QXC9,QXE,QXE2 QXE4,QXE6,QXE8,QXF,QXF2,QXM1,QXQ,QXS,QXS2,QXU,QXW,QXW2,QX2 QX22,QX26,QX4,QX7,QZ,RAC,REX4,RFR,RFR2,RH,RHA,RHA2,RHQ4,RH2 RH26,RMB4,RMD,RMG2,RNG,RSK,RSS1,RTB2,RX,RXE,RXE2,RXE4,RXU,RX4 SAC,SAD2,SCJ,SDN,SDS2,SDS3,SG24,SH,SHM,SHQ4,SHRY,SHR4,SJ,SJC SJC1,SJC5,SJG,SKM,SMB4,SMC7,SMC9,SMJ,SMJ1,SMW2,SMX4,SM11,SM12 SM14,SNX,SNX1,SSK1,SSK2,SSX2,ST,STA,STM,STP,STQ,SWG4,SWX2,SWX4 SX,SXB,SXE,SXE4,SXS4,SXU,SX4,SX7,S1CY,TCS2,TH,TX,TCX9,TXU,TX2 TX26,TX4,UH,UX,UXU,VA,VA2,VED,VED1,VED5,VED6,VGE4,VH,VHA7,VHH4 VHQ4,VMB3,VMS4,VMS7,VS,VSD,VSD7,VSX,VSX1,VSX3,VS1,VTD,VTD1 VTU1,VVA,VVA2,VW12,VX,VXD,VXD1,VXE,VXE4,VXE6,VXE7,VXG,VXM,VXU VXU1,VXW,VXW1,VXW2,VX2,VX26,VX4,WDA6,WJP,WKD6,WKT2,WKT4,WKT6 WME2
			-	(1)	1	-		
31	90605-230-000	CIRCLIP, 5MM	1	-	-	-	-----	HG1,HG12,LHW,LSS1,QSC2,QSC9,QWA4,QXW,QXW2,STM
			1	-	-	-	4764119	----- SWG4
			-	(1)	-	-		

Ref. No.	Part No.	Description	Reqd. QTY				Serial No.	Parts catalogue code
			GX160K1					
			(1)	(2)	(3)	(4)		
32	93500-03008-1G	SCREW, PAN, 3X8 (CARBURETOR NO.)	2	-	-	-	BE06J A	EN,ET,ETX,HH,KTA,LAX,LH,LX,PH,PX,QH,QHE,QNT,QT,QXB,QXW,RAC,RSK RX,RXE,SAC,SH,STA,SX,SXB,SXE,TH,UH,UX,VA,VED,VED1,VH,VS,VSD VSX,VSX1,VS1,VXE
		//	2	-	-	-	BE06J B	DS,DSP,HG1,HX,LJ,LJD,LJG,LJS,LMT,LSS,LSS1,LTK,NJ,NJG,QA,QAX,QX QXE,QXF,QXS,RFR,RH,RHA,RMD,RNG,SCJ,SJ,SJC,SJG,SKM,SMJ,SMJ1,SNX SSK1,ST,STM,STP,STQ,TX,VED5,VWA,VX,VXW,VXW1,WJP
		//	2	-	-	-	BE06U A	PHU,THU
		//	2	-	-	-	BE11C A	QXC
		//	2	-	-	-	BE65A A	HXQ,QXQ
		//	2	-	-	-	BE65B A	HG12,HH26,HX2,HX26,LAX2,LX2,LX26,PX2,QAX2,QBT2,QBT6,QBU2,QGR2 QH26,QMX2,QMZ2,QNT2,QXE2,QXE6,QXF2,QXS2,QXW2,QX2,QX26,RFR2 RHA2,RH2,RH26,RMG2,RTB2,SAD2,SG24,SMW2,SSK2,SSX2,TX2,TX26,VA2 VWA2,VW12,VXW2,VX2,VX26
		//	2	-	-	-	BE65C A	QA2,QA26,WKT2,WME2
		//	2	-	-	-	BE65G A	QSC2,QXC6,QXC9,TXC9
		//	2	-	-	-	BE66D A	VEB2,VG24
		//	-	(2)	-	-	BE06J A	
		//	-	-	2	-	UIH	
	93500-03006-1H	SCREW, PAN, 3X6 (CARBURETOR NO.)	2	(2)	-	-	BE06J B	EN,ET,ETX,HH,KTA,LAX,LH,LX,PH,PX,QH,QHE,QNT,QT,QXB,QXW,Q1,RAC RSK,RX,RXE,R1,SAC,SH,STA,SX,SXB,SXE,S1,TH,T1,UH,UX,VA,VED,VED1 VH,VH04,VS,VSD,VSX,VSX1,VS1,VXE,V1,W1
			2	-	2	-		BL,HXE2,HXE8,HXU,LHW,LJC7,LSJ,LVL,LXU,NSJ,NW,PHM,PXU,QBC2,QCB2 QCL,QGR9,QHP1,QIH1,QI2,QMH,QSC9,QS2,QVL,QWA4,QWM2,QWX2,QWX3 QXE8,QXM1,QXU,QX22,QX7,REX4,RSS1,RXE2,RXU,SDN,SHM,SHRY,SHR4 SJC1,SJC5,SMX4,SM11,SM12,SM14,SNX1,SWX2,SWX4,SXS4,SXU, SX7,S1CY TCS2, TXU,UXU,VED6,VHA7,VIH1,VMS7,VSD7,VSX3, VTD, VTD1,VTU1,VXD VXD1,VXE6,VXE7,VXM,VXU1,WDA6,WIH1,WKD6,WKT4,WKT6
		(CARBURETOR NO.)	2	-	-	-	BE06J C	DS,DSP,HG1,HX,LJ,LJD,LJG,LJS,LMT,LSS,LSS1,LTK,NJ,NJG,QA,QAX,QX QXE,QXF,QXS,RFR,RH,RHA,RMD,RNG,SCJ,SJ,SJC,SJG,SKM,SMJ,SMJ1,SNX SSK1,ST,STM,STP,STQ,TX,VED5,VWA,VX,VXW,VXW1,WJP
		//	2	-	-	-	BE06U B	PHU,THU
		//	2	-	-	-	BE11C B	QXC
		//	2	-	-	-	BE65A B	HXQ,QXQ
		//	2	-	-	-	BE65B B	HG12,HH26,HX2,HX26,LAX2,LX2,LX26,PX2,QAX2,QBT2,QBT6,QBU2,QGR2 QH26,QMX2,QMZ2,QNT2,QXE2,QXE6,QXF2,QXS2,QXW2,QX2,QX26,RFR2 RHA2,RH2,RH26,RMG2,RTB2,SAD2,SG24,SMW2,SSK2,SSX2,TX2,TX26,VA2 VWA2,VW12,VXW2,VX2,VX26
		//	2	-	-	-	BE65C B	QA2,QA26,WME2
		//	2	-	-	-	BE65G B	QSC2,QXC6,QXC9,TXC9
		//	2	-	-	-	BE66D B	VEB2,VG24
		//	2	-	-	-	BR65C B	WKT2
33	93500-04008-0A	SCREW, PAN, 4X8	1	-	-	-	HG1,HG12,LHW,LSS1,QSC2,QSC9,QXW,QXW2,STM	
			1	-	-	-	4764119	SWG4
			-	(1)	-	-		
34	93500-05008-0A	SCREW, PAN, 5X8	1	-	-	-	HG1,HG12,LHW,LSS1,QSC2,QSC9,QXW,QXW2,STM	
			1	-	-	-	4764119	SWG4
			-	(1)	-	-		



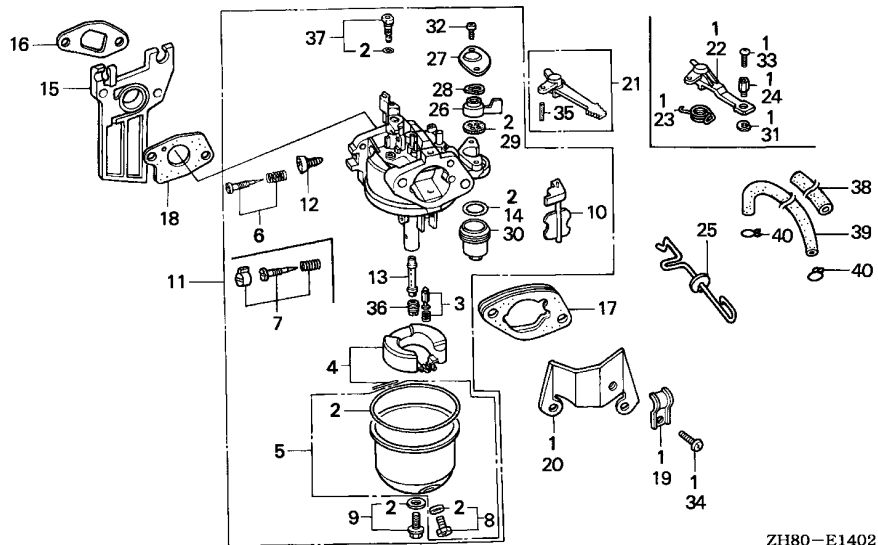

ZH80-E1402



2

Ref. No.	Part No.	Description	Reqd. QTY				Serial No.	Parts catalogue code
			(1)	(2)	(3)	(4)		
35	94305-20122	PIN, SPRING, 2X12	1	-	-	-	-----	AR,BL,DS,DSP,EN,ET,ETX,HG1,HG12,HH,HHQ4,HH26,HX,HXE,HXE2,HXE8 HXQ,HXU,HX2,HX26,HX4,KTA,LAX,LAX2,LH,LHB3,LHQ4,LJ,LJ7,LJ8,LJ9 LJS,LMT,LSJ,LSS,LSS1,LTK,LVL,LX,LXU,LX2,LX26,LX4,NJ,NJG,NSJ,NW PH,PHM,PHU,PX,PXU,PX2,QA,QAB1,QAB3,QAX,QAX2,QA2,QA26,QBC2,QBT2 QBT6,QBU2,QCB2,QCL,QGR2,QGR9,QH,QHE,QHP1,QHQ4,QH26,QI2,QKA4 QMC8,QMD6,QME4,QMH,QMX2,QMZ2,QNT,QNT2,QP,QPU,QSC2,QSC9,QS2,QT QVL,QWA4,QWM2,QWX2,QWX3,QX,QXB,QXB1,QXC,QXC6,QXC9,QXE,QXE2 QXE4,QXE6,QXE8,QXF,QXF2,QXM1,QXQ,QXS,QXS2,QXU,QXW,QXW2,QX2 QX22,QX26,QX4,QX7,RAC,REX4,RFR,RFR2,RH,RHA,RHA2,RHQ4,RH2,RH26 RMB4,RMD,RMG2,RNG,RSK,RSS1,RTB2,RX,RXE,RXE2,RXE4,RXU,RX4,SAC SAD2,SCJ,SDN,SDS2,SDS3,SG24,SH,SHM,SHQ4,SHRY,SHR4,SJ,SJC,SJC1 SJC5,SJG,SMB4,SMC7,SMC9,SMJ,SMJ1,SMW2,SMX4,SM11,SM12,SM14,SNX SNX1,SSK1,SSK2,SSX2,ST,STA,STM,STP,STQ,SWX2,SWX4, SX, SXB, SXE SXE4,SXS4,SXU,SX4,SX7,S1CY,TCS2,TH,THU,TX,TXC9,TXU,TX2,TX26 TX4,UH,UX,UXU,VA,VA2,VEB2,VED,VED1,VED5,VED6,VGE4,VG24,VH,VHA7 VHH4,VHQ4,VMB3,VMS4,VMS7,VS,VSD,VSD7,VSX,VSX1,VSX3,VS1, VTD VTD1,VTU1,VVA,VVA2,VV12,VX,VXD,VXD1,VXE,VXE4,VXE6,VXE7,VXG,VXM VXU,VXU1,VXW,VXW1,VXW2,VX2,VX26,VX4,WDA6,WJP,WKD6,WKT2,WKT4 WKT6,WME2
			1	-	-	-	-----	4764118 SWG4
			-	(1)	1	-	-----	
36	99101-ZF5-0680	JET, MAIN, #68	(1)	-	-	-	-----	HG1,HX,QA,QAX,QX,QXE,QXF,QXS,QX7,RFR,RH,RHA,SHRY,SMX4,SM11,SX7 TX,VED6,VMS7,VVA,VX,VXE7,VXW,VXW1
		(CARBURETOR NO.)	(1)	-	-	-	-----	BE06J A EN,ET,ETX,HH,KTA,LAX,LH,LX,PH,PX,QH,QHE,QNT,QT,QXB,QXW,RAC,RSK RX,RXE,SAC,SH,STA,SX,SXB,SXE,TH,UH,UX,VA,VED,VED1,VH,VS,VSD VSX,VSX1,VS1,VXE
		//	-	(1)	-	-	-----	BE06J A

Ref. No.	Part No.	Description	Reqd. QTY				Serial No.	Parts catalogue code
			(1)	(2)	(3)	(4)		
36)	99101-ZF5-0700	JET, MAIN, #70 (CARBURETOR NO.)	(1)	-	-	-	-----	HG1, HX, QA, QX, QXE, QXF, QXS, QX7, QZ, RFR, RH, RHA, SHRY, SMX4, SM11, SX7 TX, VED6, VMS7, VWA, VX, VXE7, VXW
			(1)	-	-	-	-----	BE06J A EN, ET, ETX, HH, KTA, LAX, LH, LX, PH, PX, QH, QHE, QNT, QT, QXB, QXW, RAC, RSK RX, RXE, SAC, SH, STA, SX, SXB, SXE, TH, UH, UX, VA, VED, VED1, VH, VS, VSD VSX, VSX1, VS1, VXE
	99101-ZF5-0720	JET, MAIN, #72 (CARBURETOR NO.)	1	-	-	-	-----	BE06J A RFR, RHA, VWA
			1	-	-	-	-----	BE06J A EN, ET, ETX, HG1, HH, HX, KTA, LAX, LH, LX, PH, PX, QA, QH, QHE, QNT, QT, QX QXB, QXE, QXF, QXS, QXW, RAC, RH, RSK, RX, RXE, SAC, SH, STA, SX, SXB, SXE, TH TX, UH, UX, VA, VED, VED1, VH, VS, VSD, VSX, VSX1, VS1, VX, VXE, VXW
		(CARBURETOR NO.)	(1)	-	-	-	-----	QZ
	99101-ZF5-0750	JET, MAIN, #75	1	-	-	-	-----	BE06J A QZ
	99101-ZH7-0650	JET, MAIN, #65 (CARBURETOR NO.)	(1)	(1)	-	-	-----	BE06J B BE06J B EN, ET, ETX, HH, HX, KTA, LAX, LH, LX, PH, PX, QA, QH, QHE, QNT, QT, QX, QXB QXE, QXW, Q1, RAC, RH, RSK, RX, RXE, R1, SAC, SH, STA, SX, SXB, SXE, S1, TH, TX T1, UH, UX, VA, VED, VED1, VH, VS, VSD, VSX, VSX1, VS1, VX, VXE, V1, W1
		//	(1)	-	-	-	-----	BE06J B HHQ4, HXE, HX4, LHB3, LHQ4, LX4, QAB1, QAB3, QHQ4, QKA4, QMC8, QMD6, QME4 QP, QPU, QXB1, QXE4, QX4, RHQ4, RMB4, RXE4, RX4, SDS2, SDS3, SHQ4, SMB4 SMC7, SMC9, SWG4, SXE4, SX4, TX4, VGE4, VHH4, VHQ4, VMB3, VMS4, VXE4, VXG VXU, VX4
		//	(1)	-	-	-	-----	BE65B A HH26, HX26, LX26, QBT6, QBU2, QH26, QNT2, QXE6, QXW2, QX26, RH26, SAD2 TX26, VX26
		//	-	(1)	-	-	-----	BE06J B H1, L1, U1
			-	-	(1)	-	-----	UIH
	99101-ZH7-0680	JET, MAIN, #68 (CARBURETOR NO.)	(1)	(1)	-	-	-----	BE06J B BE06J B EN, ET, ETX, HH, HX, KTA, LAX, LH, LX, PH, PX, QA, QH, QHE, QNT, QT, QX, QXB QXE, QXW, Q1, RAC, RH, RSK, RX, RXE, R1, SAC, SH, STA, SX, SXB, SXE, S1, TH, TX T1, UH, UX, VA, VED, VED1, VH, VS, VSD, VSX, VSX1, VS1, VX, VXE, V1, W1
		(CARBURETOR NO.)	(1)	-	(1)	-	-----	HXQ, UIH
			(1)	-	-	-	-----	BE06J B HHQ4, HXE, HX4, LHB3, LHQ4, LX4, QAB1, QAB3, QHQ4, QKA4, QMC8, QMD6, QME4 QP, QPU, QXB1, QXE4, QX4, RHQ4, RMB4, RXE4, RX4, SDS2, SDS3, SHQ4, SMB4 SMC7, SMC9, SWG4, SXE4, SX4, TX4, VGE4, VHH4, VHQ4, VMB3, VMS4, VXE4, VXG VXU, VX4
		//	(1)	-	-	-	-----	BE65B A HH26, HX26, LX26, QBT6, QBU2, QH26, QNT2, QXE6, QXW2, QX26, RH26, SAD2 TX26, VX26
		//	-	(1)	-	-	-----	BE06J B H1, L1, U1
	99101-ZH7-0700	JET, MAIN, #70 (CARBURETOR NO.)	1	1	-	-	-----	BE06J B BE06J B EN, ET, ETX, HH, HX, KTA, LAX, LH, LX, PH, PX, QA, QH, QHE, QNT, QT, QX, QXB QXE, QXW, Q1, RAC, RH, RSK, RX, RXE, R1, SAC, SH, STA, SX, SXB, SXE, S1, TH, TX T1, UH, UX, VA, VED, VED1, VH, VS, VSD, VSX, VSX1, VS1, VX, VXE, V1, W1
		//	1	-	-	-	-----	BE06J B HHQ4, HXE, HX4, LHB3, LHQ4, LX4, QAB1, QAB3, QHQ4, QKA4, QMC8, QMD6, QME4 QP, QPU, QXB1, QXE4, QX4, RHQ4, RMB4, RXE4, RX4, SDS2, SDS3, SHQ4, SMB4 SMC7, SMC9, SWG4, SXE4, SX4, TX4, VGE4, VHH4, VHQ4, VMB3, VMS4, VXE4, VXG VXU, VX4
		//	1	-	-	-	-----	BE65B A HH26, HX26, LX26, QBT6, QBU2, QH26, QNT2, QXE6, QXW2, QX26, RH26, SAD2 TX26, VX26
		(CARBURETOR NO.)	(1)	-	1	-	-----	HXQ, UIH
	99101-ZH7-0720	JET, MAIN, #72	1	-	-	-	-----	BE06J B H1, L1, U1
	99101-ZH8-0620	JET, MAIN, #62	(1)	-	-	-	-----	HXQ AR, QSC2, QSC9, QXC, QXC6, QXC9, SKM, TXC9



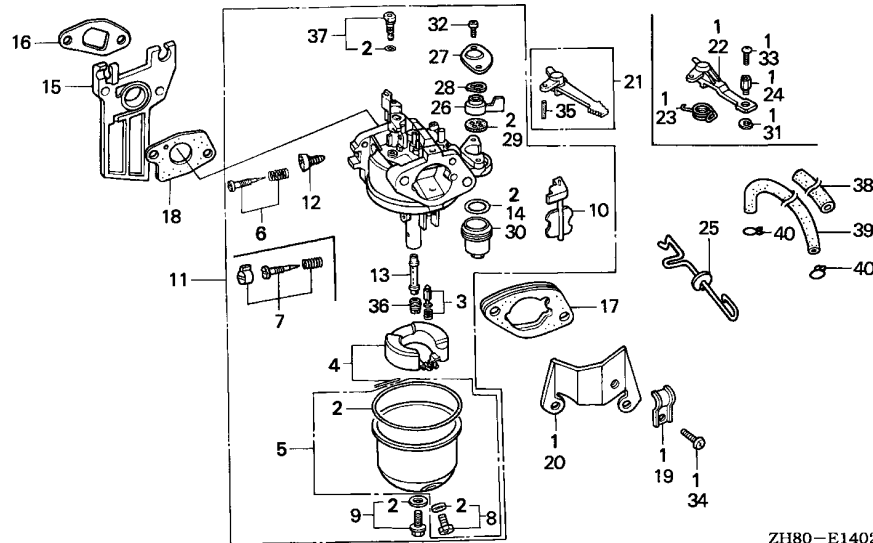

ZH80-E1402



Ref. No.	Part No.	Description	Reqd. QTY				Serial No.	Parts catalogue code	
			(1)	(2)	(3)	(4)			
			GX160K1						
36)	99101-ZH8-0650	JET, MAIN, #65	(1)	(1)	(1)	-	-----	AR,BL,DS,DSP,HG12,HXE2,HXE8,HXU,HX2,H1,LAX2,LHW,LJ,LJC7,LJD,LJG,LJS,LMT,LSJ,LSS1,LTK,LVL,LXU,LX2,L1,NJ,NJG,NSJ,NW,PHM,PHU,PXU,PX2,QAX2,QA2,QA26,QBC2,QBT2,QCB2,QCL,QGR2,QGR9,QHP1,QIH1,QI2,QMH,QMX2,QMZ2,QSC2,QSC9,QS2,QVL,QWM2,QWX2,QWX3,QXC,QXC6,QXC9,QXE2,QXE8,QXF2,QXM1,QXS2,QXU,QX2,QX22,REX4,RFR2,RHA2,RH2,RMD,RMG2,RNG,RSS1,RTB2,RXE2,RXU,SCJ,SDN,SG24,SHM,SHR4,SJ,SJC,SJC1,SJC5,SJG,SKM,SMJ,SMJ1,SMW2,SM12,SM14,SNX,SNX1,SSK1,SSK2,SSX2,STP,STQ,SWX2,SWX4,SXU,S1CY,TCS2,THU,TXC9,TXU,TX2,UXU,U1,VA2,VEB2,VED5,VG24,VHA7,VIH1,VSD7,VSX3,VTD,VTD1,VTU1,VWA2,VW12,VXD,VXD1,VXM,VXU1,VXW2,VX2,WDA6,WIH1,WJP,WKD6,WKT2,WKT6,WME2	
		(CARBURETOR NO.)	(1)	(1)	-	-	BE06J C	-----	EN,ET,ETX,HH,HHQ4,HX,HXE,HX4,KTA,LAX,LH,LHB3,LHQ4,LX,LX4,PH,PX,QA,QAB1,QAB3,QH,QHE,QHQ4,QKA4,QMC8,QMD6,QME4,QNT,QP,QPU,QT,QX,QXB,QXB1,QXE,QXE4,QXW,QX4,Q1,RAC,RH,RHQ4,RMB4,RSK,RX,RXE,RXE4,RX4,R1,SAC,SDS2,SDS3,SH,SHQ4,SMB4,SMC7,SMC9,STA,SWG4,SX,SXB,SXE,SXE4,SX4,S1,TH,TX,TX4,T1,UH,UX,VA,VED,VED1,VGE4,VH,VHH4,VHQ4,VMB3,VMS4,VS,VSD,VSX,VSX1,VS1,VX,VXE,VXE4,VXG,VXU,VX4,V1,W1
		..	(1)	-	-	-	BE65B B	-----	HH26,HX26,LX26,QBT6,QBU2,QH26,QNT2,QXE6,QXW2,QX26,RH26,SAD2,TX26,VX26

Ref. No.	Part No.	Description	Reqd. QTY				Serial No.	Parts catalogue code
			GX160K1					
			(1)	(2)	(3)	(4)		
36)	99101-ZH8-0680	JET, MAIN, #68 (CARBURETOR NO.)	1	(1)	(1)	-	AR, H1, L1, QIH1, QSC2, QSC9, QXC, QXC6, QXC9, SKM, TXC9, U1, VIH1, WIH1, EN, ET, ETX, HH, HHQ4, HX, HXE, HX4, KTA, LAX, LH, LHB3, LHQ4, LX, LX4, PH, PX, QA, QAB1, QAB3, QH, QHE, QHQ4, QKA4, QMC8, QMD6, QME4, QNT, QP, QPU, QT, QX, QXB, QXB1, QXE, QXE4, QXW, QX4, Q1, RAC, RH, RHQ4, RMB4, RSK, RX, RXE, RXE4, RX4, R1, SAC, SDS2, SDS3, SH, SHQ4, SMB4, SMC7, SMC9, STA, SWG4, SX, SXB, SXE, SXE4, SX4, S1, TH, TX, TX4, T1, UH, UX, VA, VED, VED1, VGE4, VH, VHH4, VHQ4, VMB3, VMS4, VS, VSD, VSX, VSX1, VS1, VX, VXE, VXE4, VXG, VXU, VX4, V1, W1	
		(CARBURETOR NO.)	(1)	-	-	-	BL, DS, DSP, HG12, HXE2, HXE8, HXU, HX2, LAX2, LHW, LJ, LJC7, LJD, LJG, LJS, LMT, LJS, LSS1, LTK, LVL, LXU, LX2, NJ, NJG, NSJ, NW, PHM, PHU, PXU, PX2, QAX2, QA2, QA26, QBC2, QBT2, QCB2, QCL, QGR2, QGR9, QHP1, QI2, QMH, QMX2, QMZ2, QS2, QVL, QWM2, QWX2, QWX3, QXE2, QXE8, QXF2, QXM1, QXQ, QXS2, QXU, QX2, QX22, REX4, RFR2, RHA2, RH2, RMD, RMG2, RNG, RSS1, RTB2, RXE2, RXU, SCJ, SDN, SG24, SHM, SHR4, SJ, SJC, SJC1, SJC5, SJG, SMJ, SMJ1, SMW2, SM12, SM14, SNX, SNX1, SSK1, SSK2, SSS2, ST, STM, STP, STQ, SWX2, SWX4, SXU, S1CY, TCS2, THU, TXU, TX2, UXU, VA2, VEB2, VED5, VG24, VHA7, VSD7, VSX3, VTD, VTD1, VTU1, VWA2, VW12, VXD, VXD1, VXM, VXU1, VXW2, VX2, WDA6, WJP, WKD6, WKT2, WKT4, WKT6, WME2	
		(CARBURETOR NO.)	(1)	-	-	-	HH26, HX26, LX26, QBT6, QBU2, QH26, QNT2, QXE6, QXW2, QX26, RH26, SAD2, TX26, VX26	
	99101-ZH8-0700	JET, MAIN, #70	1	1	1	-	BL, DS, DSP, HG12, HXE2, HXE8, HXU, HX2, H1, LAX2, LHW, LJ, LJC7, LJD, LJG, LJS, LMT, LSS, LSS1, LTK, LVL, LXU, LX2, L1, NJ, NJG, NSJ, NW, PHM, PHU, PXU, PX2, QAX, QAX2, QA2, QA26, QBC2, QBT2, QCB2, QCL, QGR2, QGR9, QHP1, QIH1, QI2, QMH, QMX2, QMZ2, QS2, QVL, QWM2, QWX2, QWX3, QXE2, QXE8, QXF2, QXS2, QXU, QX2, QX22, QX7, REX4, RFR2, RHA2, RH2, RMD, RMG2, RNG, RSS1, RTB2, RXE2, RXU, SCJ, SDN, SG24, SHM, SHRY, SHR4, SJ, SJC, SJC1, SJC5, SJG, SMJ, SMJ1, SMW2, SMX4, SM11, SM12, SM14, SNX, SNX1, SSK1, SSK2, SSS2, STP, STQ, SWX2, SWX4, SXU, SX7, S1CY, TCS2, THU, TXU, TX2, UXU, U1, VA2, VEB2, VED5, VED6, VG24, VHA7, VIH1, VMS7, VSD7, VSX3, VTD, VTD1, VTU1, VWA2, VW12, VXD, VXD1, VXE7, VXM, VXU1, VXW1, VXW2, VX2, WDA6, WIH1, WJP, WKD6, WKT2, WKT4, WKT6, WME2	
		(CARBURETOR NO.)	1	1	-	-	EN, ET, ETX, HH, HHQ4, HXE, HX4, KTA, LAX, LH, LHB3, LHQ4, LX, LX4, PH, PX, QAB1, QAB3, QH, QHE, QHQ4, QKA4, QMC8, QMD6, QME4, QNT, QP, QPU, QT, QXB, QXB1, QXE4, QXW, QX4, Q1, RAC, RHQ4, RMB4, RSK, RX, RXE, RXE4, RX4, R1, SAC, SDS2, SDS3, SH, SHQ4, SMB4, SMC7, SMC9, STA, SWG4, SX, SXB, SXE, SXE4, SX4, S1, TH, TX4, T1, UH, UX, VA, VED, VED1, VGE4, VH, VHH4, VHQ4, VMB3, VMS4, VS, VSD, VSX, VSX1, VS1, VXE, VXE4, VXG, VXU, VX4, V1, W1	
		//	1	-	-	-	HG1, HX, QA, QX, QXE, QXF, QXS, RFR, RH, RHA, TX, VWA, VX, VXW	
		//	1	-	-	-	HH26, HX26, LX26, QBT6, QBU2, QH26, QNT2, QXE6, QXW2, QX26, RH26, SAD2, TX26, VX26	
	99101-ZH8-0720	JET, MAIN, #72	(1)	-	-	-	QXQ, ST, STM	
		(CARBURETOR NO.)	1	-	-	-	QXQ, ST, STM	
37	99204-ZE0-0380	JET SET, PILOT, #38 (CARBURETOR NO.)	1	-	-	-	QZ, RFR, RHA, ST, STM, VWA	
		(CARBURETOR NO.)	1	-	-	-	BE06J A DS, DSP, EN, ET, ETX, HG1, HH, HX, KTA, LAX, LH, LJ, LJS, LMT, LTK, LX, PH, PX, QA, QH, QHE, QNT, QT, QX, QXB, QXE, QXF, QXS, QXW, RAC, RH, RMD, RSK, RX, RXE, SAC, SCJ, SH, SJ, SMJ, SMJ1, STA, STP, STQ, SX, SXB, SXE, TH, TX, UH, UX, VA, VED, VED1, VH, VS, VSD, VSX, VSX1, VS1, VX, VXE, VXW	
		//	1	-	-	-	BE11C B QXC	
		//	-	(1)	-	-	BE06J A	
	99204-ZE0-0400	JET SET, PILOT, #40 (CARBURETOR NO.)	1	-	-	-	HXQ, QSC2, QSC9, QXC6, QXC9, QXQ, TXC9	
		(CARBURETOR NO.)	1	-	-	-	QXC	
	99204-ZE2-0380	JET SET, PILOT, #38	1	-	-	-	AR	



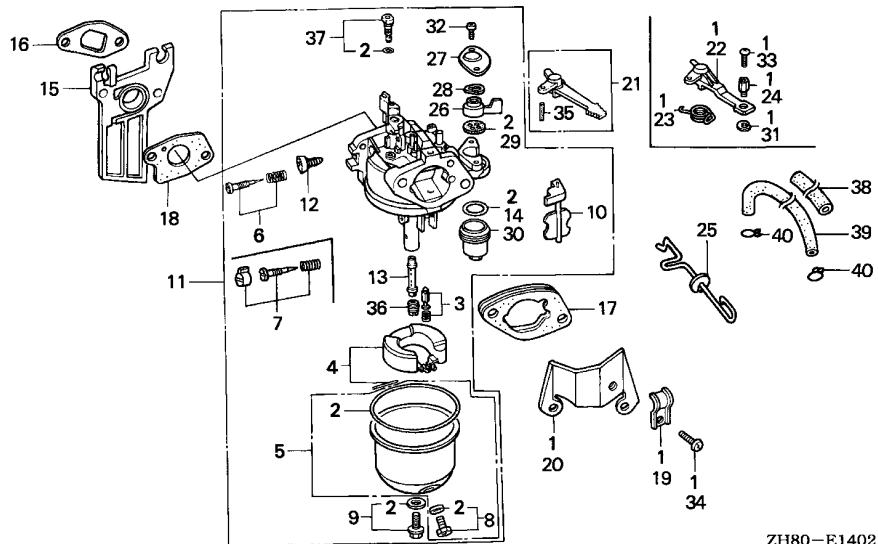

ZH80-E1402



2

Ref. No.	Part No.	Description	Reqd. QTY				Serial No.	Parts catalogue code
			(1)	(2)	(3)	(4)		
37)	99204-ZE0-0350	JET SET, PILOT, #35	1	-	-	-	-----	BL, HG12, HHQ4, HH26, HXE, HXE2, HXE8, HXU, HX2, HX26, HX4, LAX2, LHB3, LHQ4, LHW, LJC7, LJD, LJG, LSJ, LSS, LSS1, LVL, LXU, LX2, LX26, LX4, NJ, NJG, NSJ, NW, PHM, PHU, PXU, PX2, QAB1, QAB3, QAX, QAX2, QA2, QA26, QBC2, QBT2, QBT6, QBU2, QCB2, QCL, QGR2, QGR9, QHP1, QHQ4, QH26, QI2, QKA4, QMC8, QMD6, QME4, QMH, QMX2, QMZ2, QNT2, QP, QPU, QS2, QVL, QWA4, QWM2, QWX2, QWX3, QXB1, QXE2, QXE4, QXE6, QXE8, QXF2, QXM1, QXS2, QXU, QXW2, QX2, QX22, QX26, QX4, QX7, REX4, RFR2, RHA2, RHQ4, RH2, RH26, RMB4, RMG2, RNG, RSS1, RTB2, RXE2, RXE4, RXU, RX4, SAD2, SDN, SDS2, SDS3, SG24, SHM, SHQ4, SHRY, SHR4, SJC, SJC1, SJC5, SJG, SKM, SMB4, SMC7, SMC9, SMW2, SMX4, SM11, SM12, SM14, SNX, SNX1, SSK1, SSK2, SSX2, SWG4, SWX2, SWX4, SXE4, SXS4, SXU, SX4, SX7, S1CY, TCS2, THU, TXU, TX2, TX26, TX4, UXU, VA2, VEB2, VED5, VED6, VGE4, VG24, VHA7, VHH4, VHQ4, VMB3, VMS4, VMS7, VSD7, VSX3, VTD, VTD1, VTU1, VWA2, VW12, VXD, VXD1, VXE4, VXE6, VXE7, VXG, VXM, VXU, VXU1, VXW1, VXW2, VX2, VX26, VX4, WDA6, WJP, WKD6, WKT2, WKT4, WKT6, WME2, DS, DSP, EN, ET, ETX, HG1, HH, HX, KTA, LAX, LH, LJ, LJS, LMT, LTK, LX, PH, PX, QA, QH, QHE, QNT, QT, QX, QXB, QXE, QXF, QXS, QXW, RAC, RFR, RH, RHA, RMD, RSK, RX, RXE, SAC, SCJ, SH, SJ, SMJ, SMJ1, STA, STP, STQ, SX, SXB, SXE, TH, TX, UH, UX, VA, VED, VED1, VH, VS, VSD, VSX, VSX1, VS1, VWA, VX, VXE, VXW
		(CARBURETOR NO.)	1	-	-	-	BE06J B	-----
		//	-	(1)	-	-	BE06J B	-----
38	16854-ZE1-000	RUBBER, SUPPORTER (107MM)	1	-	-	-	-----	AR
	16854-ZG0-960	RUBBER, SUPPORTER	1	-	-	-	-----	QCL
39	95001-45300-40	TUBE, FUEL, 4.5X300	1	-	-	-	-----	QCL
	95001-45400-60	TUBE, FUEL, 4.5X400	1	-	-	-	-----	AR
	95001-45001-60M)	(95001-45001-60M)	1	-	-	-	-----	AR
40	95002-02080	CLIP, TUBE (B8)	2	-	-	-	-----	QCL
	95002-40800-08	CLAMP, TUBE (D8)	2	-	-	-	-----	AR

E-14-3

CARBURETOR(4)

M12

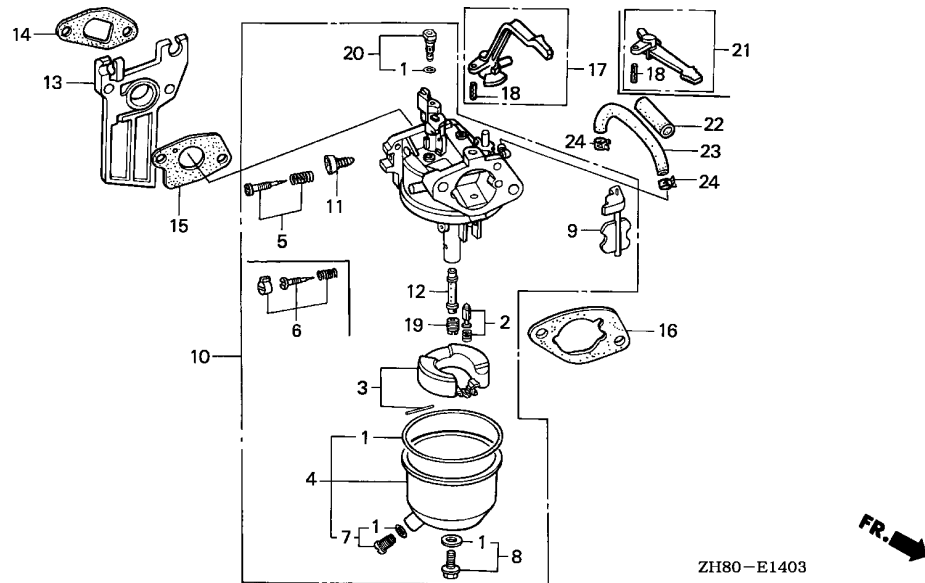

Ref. No.	L.O.N.	(Relative ref. Number) Description	F.R.T.
2	3111E1	(3) VALVE SET, FLOAT AND/OR FLOAT SET	0.3
5	3111D7	(6) SCREW SET, PILOT	0.2
10	3111F3	CARBURETOR	0.2
13	3111C0	(14) INSULATOR, CARBURETOR AND/OR PACKING, INSULATOR	0.2
15	3111C8	PACKING, CARBURETOR	0.2
17	8101F9	LEVER, CARBURETOR CHOKE	0.2
19	3111C3	JET, MAIN	0.3
23	3101F6	TUBE, FUEL	0.2

Ref. No.	Part No.	Description	Reqd. QTY				Serial No.	Parts catalogue code
			(1)	(2)	(3)	(4)		
1	16010-ZB1-015	GASKET SET	1	-	-	-	EMA,EMA2,KR,VED2,VED3,VED7,VEN2,VES,VMT,VPM4,VPM5,VPM7,VPR4,VPR7,VSB1,VSD1,VSG,VS17,VS3,VS4,VTE2,VTX,VTX1	
2	16011-ZE0-005	VALVE SET, FLOAT	1	-	-	-	EMA,EMA2,KR,VED2,VED3,VED7,VEN2,VES,VMT,VPM4,VPM5,VPM7,VPR4,VPR7,VSB1,VSD1,VSG,VS17,VS3,VS4,VTE2,VTX,VTX1	
3	16013-ZE0-005	FLOAT SET	1	-	-	-	EMA,EMA2,KR,VED2,VED3,VED7,VEN2,VES,VMT,VPM4,VPM5,VPM7,VPR4,VPR7,VSB1,VSD1,VSG,VS17,VS3,VS4,VTE2,VTX,VTX1	
4	16015-ZE1-811	CHAMBER SET, FLOAT	1	-	-	-	KR	
	16015-ZH8-D20	(CARBURETOR NO.)	1	-	-	-	BE51A A EMA2,VED2	
	16015-ZE0-831	(CARBURETOR NO.)	1	-	-	-	BE51A A EMA,VED3,VSD1,VS17,VS3,VS4	
	16015-ZE0-831	///	1	-	-	-	BE67A A BE67A A VED2	
	16015-ZE0-831	(CARBURETOR NO.)	1	-	-	-	VED7,VEN2,VES,VMT,VPM4,VPM5,VPM7,VPR4,VPR7,VSB1,VSG,VS17,VTE2,VTX,VTX1	
	16015-ZE0-831	///	1	-	-	-	BE51A B EMA,VED3,VSD1,VS17,VS3,VS4	
	16015-ZE0-831	///	1	-	-	-	BE67A A EMA2	
	16015-ZE0-831	///	1	-	-	-	BE67A B VED2	
5	16016-ZE0-005	SCREW SET, PILOT	1	-	-	-	VED3,VSB1,VSD1,VS17,VS3,VS4,VTX,VTX1	
	16016-ZE0-005	(CARBURETOR NO.)	1	-	-	-	BE51A A VED2	
	16016-ZE0-005	///	1	-	-	-	BE51A B EMA,VMT	
	16016-ZE0-005	///	1	-	-	-	BE67A B KR	
6	16016-ZH7-W01	SCREW SET, PILOT	1	-	-	-	EMA2,VED7,VEN2,VES,VPM4,VPM5,VPM7,VPR4,VPR7,VSG,VS17,VTE2	
	16016-ZH7-W01	(CARBURETOR NO.)	1	-	-	-	BE67A A VED2	
	16016-ZH7-W01	///	1	-	-	-	BE67A B EMA,VED3,VMT	
	16016-ZH7-W01	///	1	-	-	-	BE67C A KR	
7	16024-ZE1-811	SCREW SET, DRAIN	1	-	-	-	EMA2,VED2,VED7,VEN2,VES,VPM4,VPM5,VPM7,VPR4,VPR7,VSG,VS17,VTE2	
	16024-ZE1-811	(CARBURETOR NO.)	1	-	-	-	BE67A B VMT	



E-14-3

CARBURETOR(4)

M13

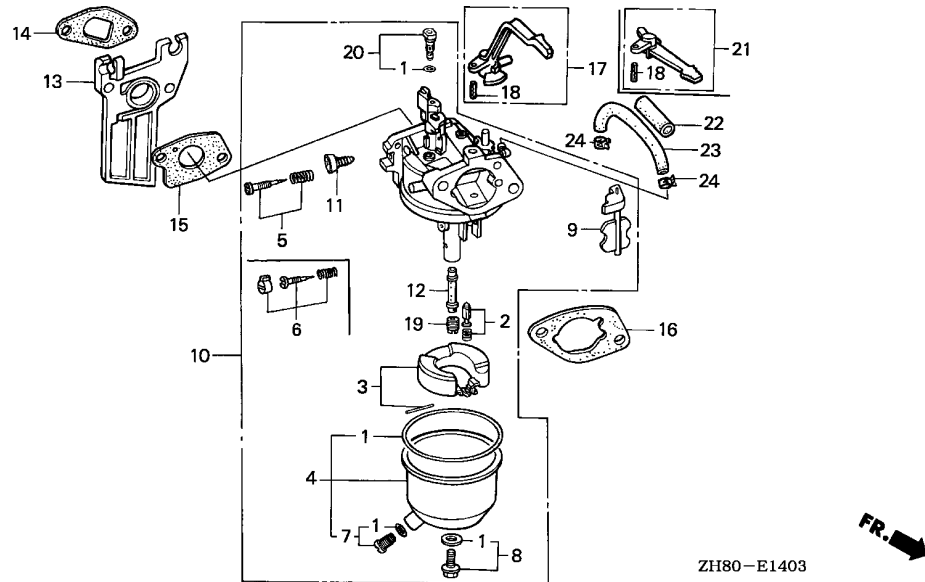

Ref. No.	Part No.	Description	Reqd. QTY				Serial No.	Parts catalogue code
			(1)	(2)	(3)	(4)		
8	16028-ZE0-005	SCREW SET	1	-	-	-	EMA,EMA2,KR,VED2,VED3,VED7,VEN2,VES,VMT,VPM4,VPM5,VPM7,VPR4,VPR7,VSB1,VSD1,VSG,VS17,VS3,VS4,VTE2,VTX,VTX1	
9	16044-ZE0-005	CHOKE SET	1	-	-	-	EMA,EMA2,VED2,VED3,VED7,VEN2,VES,VMT,VPM4,VPM5,VPM7,VPR4,VPR7,VSB1,VSD1,VSG,VS17,VS3,VS4,VTE2,VTX,VTX1	
	16044-ZK8-V00	1	-	-	-	KR	
10	16100-ZH8-D20	CARBURETOR ASSY. (BE51A A) ..	1	-	-	-	3417142 VED2 4015544 EMA,VED3,VSD1,VS17,VS3,VS4	
	16100-ZH8-D21	CARBURETOR ASSY. (BE51A B) ..	1	-	-	-	VTX 6276049 VMT,VSB1,VTX1	
	16100-ZH8-E80	CARBURETOR ASSY. (BE67A A) ..	1	-	-	4015545	6276049 EMA,VED3,VSD1,VS17,VS3,VS4	
	16100-ZH8-E81	CARBURETOR ASSY. (BE67A B) ..	1	-	-	3417143	4067479 EMA2 4067479 VED2	
	16100-ZK8-V01	CARBURETOR ASSY. (BE67B B) ..	1	-	-	-	VED7,VEN2,VES,VPM4,VPM5,VPM7,VPR4,VPR7,VSG,VS17,VTE2	
	16100-ZK8-T51	CARBURETOR ASSY. (BE67C A) ..	1	-	-	6276050	EMA2,VED2 EMA,VED3,VMT,VSB1,VSD1,VS17,VS3,VS4,VTX1	
11	16124-ZE0-005	SCREW, THROTTLE STOP	1	-	-	-	EMA,EMA2,KR,VED2,VED3,VED7,VEN2,VES,VMT,VPM4,VPM5,VPM7,VPR4,VPR7,VSB1,VSD1,VSG,VS17,VS3,VS4,VTE2,VTX,VTX1	
12	16166-ZH8-D20	NOZZLE, MAIN	1	-	-	-	VED3,VSB1,VSD1,VS17,VS3,VS4,VTX,VTX1	
		(CARBURETOR NO.)	1	-	-	-	BE51A A VED2 BE51A B EMA,VMT	
	16166-ZH8-E80	///	1	-	-	-	EMA2,VED7,VEN2,VES,VPM4,VPM5,VPM7,VPR4,VPR7,VSG,VS17,VTE2	
		(CARBURETOR NO.)	1	-	-	-	BE67A A VED2 BE67A B EMA,VED3,VMT	
	16166-ZK8-V01	///	1	-	-	-	KR	

Ref. No.	Part No.	Description	Reqd. QTY				Serial No.	Parts catalogue code
			(1)	(2)	(3)	(4)		
13	16211-ZE1-000	INSULATOR, CARBURETOR	1	-	-	-	EMA,EMA2,KR,VED2,VED3,VED7,VEN2,VES,VMT,VPM4,VPM5,VPM7,VPR4,VPR7,VSB1,VSD1,VSG,VSU,VS17,VS3,VS4,VTE2,VTX,VTX1	
14	16212-ZH8-800	PACKING, INSULATOR	1	-	-	-	EMA,EMA2,KR,VED2,VED3,VED7,VEN2,VES,VMT,VPM4,VPM5,VPM7,VPR4,VPR7,VSB1,VSD1,VSG,VSU,VS17,VS3,VS4,VTE2,VTX,VTX1	
15	16221-ZH8-800	PACKING, CARBURETOR	1	-	-	-	3427128 VED2,VED3,VSD1,VS3,VS4	
	16221-ZH8-801		1	-	-	-	3427858 EMA	
			1	-	-	-	EMA2,KR,VED7,VEN2,VES,VMT,VPM4,VPM5,VPM7,VPR4,VPR7,VSB1,VSG,VSU,VS17,VTE2,VTX,VTX1	
			1	-	-	-	3427129 VED2,VED3,VSD1,VS3,VS4	
			1	-	-	-	3427859 EMA	
16	16269-ZE1-800	PACKING, AIR CLEANER	1	-	-	-	EMA,EMA2,KR,VED2,VED3,VED7,VEN2,VES,VMT,VPM4,VPM5,VPM7,VPR4,VPR7,VSB1,VSD1,VSG,VSU,VS17,VS3,VS4,VTE2,VTX,VTX1	
17	16610-ZB2-000	LEVER COMP., CHOKE	1	-	-	-	EMA,EMA2,VED2,VED3,VED7,VEN2,VES,VMT,VPM4,VPM5,VPM7,VPR4,VPR7,VSB1,VSD1,VSG,VSU,VS17,VS3,VS4,VTE2,VTX,VTX1	
18	94305-20122	PIN, SPRING, 2X12	1	-	-	-	EMA,EMA2,KR,VED2,VED3,VED7,VEN2,VES,VMT,VPM4,VPM5,VPM7,VPR4,VPR7,VSB1,VSD1,VSG,VSU,VS17,VS3,VS4,VTE2,VTX,VTX1	
19	99101-ZF5-0700	JET, MAIN, #70 (CARBURETOR NO.)	(1)	-	-	-	BE51A A VED2,VED3,VSD1,VSU,VS3,VS4	
	99101-ZF5-0720	JET, MAIN, #72 (CARBURETOR NO.)	(1)	-	-	-	BE51A A VED2,VED3,VSD1,VSU,VS3,VS4	
	99101-ZF5-0750	JET, MAIN, #75 (CARBURETOR NO.)	1	-	-	-	BE51A A VED2,VED3,VSD1,VSU,VS3,VS4	
	99101-ZH7-0700	JET, MAIN, #70 (CARBURETOR NO.)	(1)	-	-	-	BE67A A BE67A A VED2	
	99101-ZH7-0720	JET, MAIN, #72 (CARBURETOR NO.)	(1)	-	-	-	BE67A A BE67A A VED2	
	99101-ZH7-0750	JET, MAIN, #75 (CARBURETOR NO.)	1	-	-	-	BE67A A BE67A A VED2	
	99101-ZH8-0620	JET, MAIN, #62	(1)	-	-	-	KR	
	99101-ZH8-0650	JET, MAIN, #65	(1)	-	-	-	KR	
	99101-ZH8-0680	JET, MAIN, #68	1	-	-	-	KR	
	99101-ZH8-0700	JET, MAIN, #70 (CARBURETOR NO.)	(1)	-	-	-	EMA,EMA2,VED7,VEN2,VES,VMT,VPM4,VPM5,VPM7,VPR4,VPR7,VSB1,VSG,VSU,VS17,VTE2,VTX,VTX1	
			(1)	-	-	-	BE51A B VED3,VSD1,VSU,VS3,VS4	
			(1)	-	-	-	BE67A B VED2	
	99101-ZH8-0720	JET, MAIN, #72 (CARBURETOR NO.)	(1)	-	-	-	EMA,EMA2,VED7,VEN2,VES,VMT,VPM4,VPM5,VPM7,VPR4,VPR7,VSB1,VSG,VSU,VS17,VTE2,VTX,VTX1	
			(1)	-	-	-	BE51A B VED3,VSD1,VSU,VS3,VS4	
			(1)	-	-	-	BE67A B VED2	
	99101-ZH8-0750	JET, MAIN, #75 (CARBURETOR NO.)	1	-	-	-	EMA,EMA2,VED7,VEN2,VES,VMT,VPM4,VPM5,VPM7,VPR4,VPR7,VSB1,VSG,VSU,VS17,VTE2,VTX,VTX1	
			1	-	-	-	BE51A B VED3,VSD1,VSU,VS3,VS4	
			1	-	-	-	BE67A B VED2	
20	99204-ZE0-0380	JET SET, PILOT, #38 (CARBURETOR NO.)	1	-	-	-	BE51A A VED2	
			1	-	-	-	BE51A B EMA,VED3,VMT,VSB1,VSD1,VSU,VS3,VS4,VTX,VTX1	
	99204-ZE2-0380		1	-	-	-	KR	
	99204-ZE0-0350	JET SET, PILOT, #35 (CARBURETOR NO.)	1	-	-	-	EMA2,VED7,VEN2,VES,VPM4,VPM5,VPM7,VPR4,VPR7,VSG,VSU,VS17,VTE2	
			1	-	-	-	BE67A A VED2	
			1	-	-	-	BE67A B EMA,VED3,VMT,VSB1,VSD1,VSU,VS3,VS4,VTX,VTX1	
21	16610-ZE1-000	LEVER COMP., CHOKE (STD.)	1	-	-	-	KR	
22	16854-ZH8-000	RUBBER, SUPPORTER (107MM)	1	-	-	-	KR	
23	95001-45400-60	TUBE, FUEL, 4.5X400 (95001-45001-60M)	1	-	-	-	KR	
24	95002-40800-08	CLAMP, TUBE (D8)	2	-	-	-	KR	



E-14-4

CARBURETOR(5)

M15

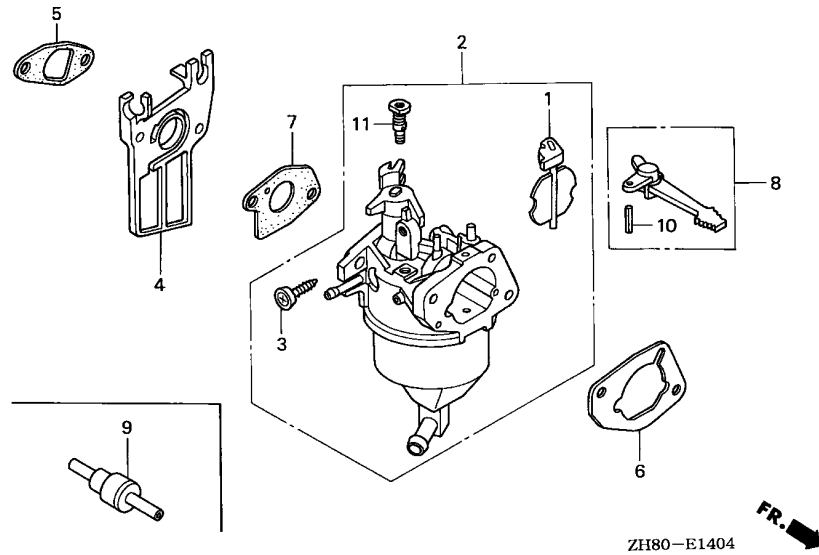

Ref. No.	L.O.N.	(Relative ref. Number) Description	F.R.T.
2	3111F3	CARBURETOR	0.2
4	3111C0	(5) INSULATOR, CARBURETOR AND/OR PACKING, INSULATOR	0.2
7	3111C8	PACKING, CARBURETOR	0.2
8	8101F9	LEVER, CARBURETOR CHOKE	0.2
9	311175	VALVE, DASHPOT CHECK	0.1

2

Ref. No.	Part No.	Description	Reqd. QTY				Serial No.	Parts catalogue code
			(1)	(2)	(3)	(4)		
			GX160K1					
1	16044-ZH8-831	CHOKE SET	-	-	-	1		
2	16100-ZH8-831	CARBURETOR ASSY. (BELDA A) ..	-	-	-	1		
3	16124-ZE0-005	SCREW, THROTTLE STOP	-	-	-	1		
4	16211-ZE1-000	INSULATOR, CARBURETOR	-	-	-	1		
5	16212-ZH8-800	PACKING, INSULATOR	-	-	-	1		
6	16220-ZE1-020	SPACER COMP., CARBURETOR	-	-	-	1		
7	16221-ZH8-801	PACKING, CARBURETOR	-	-	-	1		
8	16610-ZE1-000	LEVER COMP., CHOKE (STD.)	-	-	-	1		
9	36135-PH3-004	VALVE, DASHPOT CHECK	-	-	-	(1)		
10	94305-20122	PIN, SPRING, 2X12	-	-	-	1		
11	99204-ZE0-0350	JET SET, PILOT, #35	-	-	-	1		

E-14-5

CARBURETOR(6)

M16

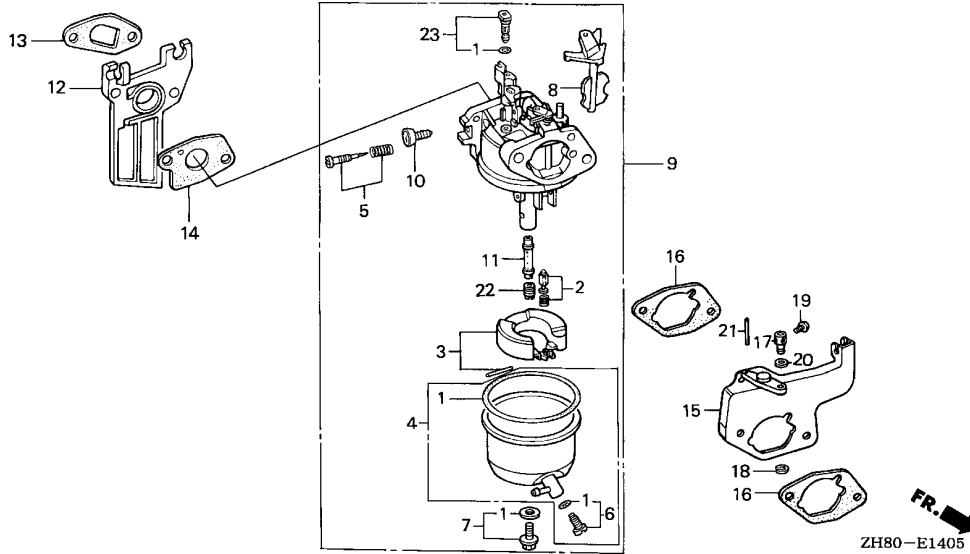

Ref. No.	L.O.N.	(Relative ref. Number) Description	F.R.T.
1	3111G1	GASKET SET, CARBURETOR(A) (3)	0.2
2	3111E1	VALVE SET, FLOAT AND/OR FLOAT SET	0.3
5	3111D7	SCREW SET, PILOT	0.2
9	3111F3	CARBURETOR (13)	0.2
12	3111C0	INSULATOR, CARBURETOR AND/OR PACKING, INSULATOR	0.2
14	3111C8	PACKING, CARBURETOR	0.2
15	8101M5	STAY, CHOKE	0.2
16	3121D9	PACKING, AIR CLEANER	0.2
22	3111C3	JET, MAIN	0.3

Ref. No.	Part No.	Description	Reqd. QTY				Serial No.	Parts catalogue code
			(1)	(2)	(3)	(4)		
1	16010-ZB9-005	GASKET SET	1	-	-	-	NJC1	
2	16011-ZE0-005	VALVE SET, FLOAT	1	-	-	-	NJC1	
3	16013-ZE0-005	FLOAT SET	1	-	-	-	NJC1	
4	16015-ZB9-005	CHAMBER SET, FLOAT	1	-	-	-	NJC1	
5	16016-ZE0-005	SCREW SET, PILOT	1	-	-	-	NJC1	
6	16024-ZB9-005	SCREW SET, DRAIN	1	-	-	-	NJC1	
7	16028-ZE0-005	SCREW SET	1	-	-	-	NJC1	
8	16044-ZE7-005	CHOKE SET	1	-	-	-	NJC1	
9	16100-ZH8-D62	CARBURETOR ASSY. (BE51B B)	1	-	-	-	NJC1	
10	16124-ZE0-005	SCREW, THROTTLE STOP	1	-	-	-	NJC1	
11	16166-ZH8-D60	NOZZLE, MAIN	1	-	-	-	NJC1	
12	16211-ZE1-000	INSULATOR, CARBURETOR	1	-	-	-	NJC1	
13	16212-ZH8-800	PACKING, INSULATOR	1	-	-	-	NJC1	
14	16221-ZH8-801	PACKING, CARBURETOR	1	-	-	-	NJC1	
15	16260-ZB6-000	STAY COMP., CHOKE	1	-	-	-	NJC1	
16	16269-ZE1-800	PACKING, AIR CLEANER	2	-	-	-	NJC1	
17	16617-890-010	HOLDER, CABLE	1	-	-	-	NJC1	
18	90605-230-000	CIRCLIP, 5MM	1	-	-	-	NJC1	
19	93500-04008-0A	SCREW, PAN, 4X8	1	-	-	-	NJC1	
20	94101-06800	WASHER, PLAIN, 6MM	1	-	-	-	NJC1	
21	94305-20182	PIN, SPRING, 2X18	1	-	-	-	NJC1	
22	99101-ZH8-0650	JET, MAIN, #65	(1)	-	-	-	NJC1	
	99101-ZH8-0680	JET, MAIN, #68	(1)	-	-	-	NJC1	
	99101-ZH8-0700	JET, MAIN, #70	1	-	-	-	NJC1	
23	99204-ZE0-0350	JET SET, PILOT, #35	1	-	-	-	NJC1	

E-15

AIR CLEANER(1)

N 1

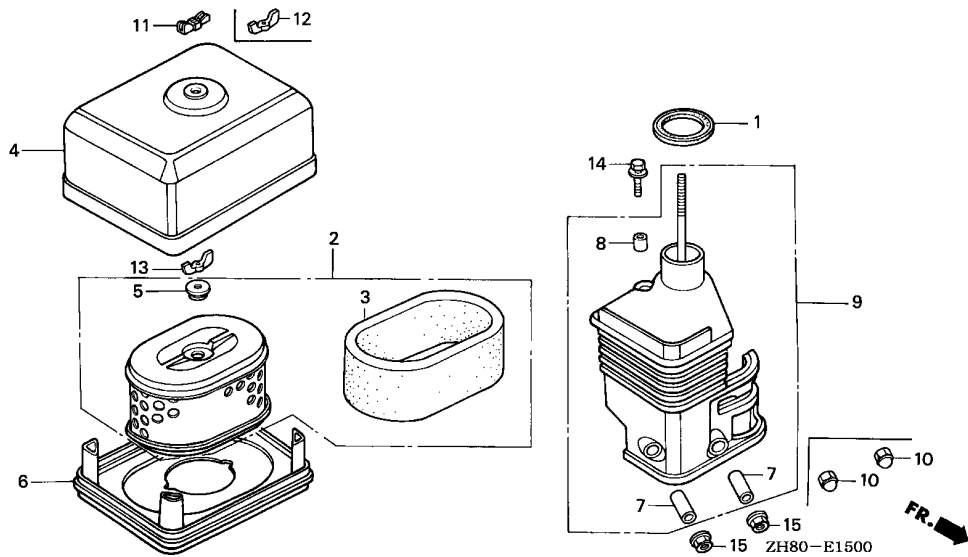

Ref. No.	L.O.N.	(Relative ref. Number) Description	F.R.T.
2	3121B8	ELEMENT, AIR CLEANER	0.1
3	3121C1	FILTER, OUTER	0.1
6	3121D6	NOSE, SILENCER	0.1
9	3121B4	ELBOW, AIR CLEANER	0.1

Ref. No.	Part No.	Description	Reqd. QTY				Serial No.	Parts catalogue code	
			(1)	(2)	(3)	(4)			
1	16271-ZE1-000	PACKING, ELBOW	1	-	1	-	HG1, HG12, HH, HHQ4, HH26, HX, HXE, HXE2, HXE8, HXQ, HXU, HX2, HX26, HX4, KTA, LAX, LAX2, LH, LHB3, LHQ4, LJS, LSJ, LX, LXU, LX2, LX26, LX4, NW, PH, PHM, PHU, PX, PXU, PX2, QAX, QAX2, QBC2, QBT2, QBT6, QBU2, QCB2, QCL, QE, QFE4, QGR2, QGR9, QH, QHE, QHP1, QHQ4, QH26, QI2, QKA4, QMC8, QMD6, QMX2, QMZ2, QNT, QNT2, QP, QPU, QS2, QWA4, QWM2, QWX2, QWX3, QX, QXB, QXB1, QXE, QXE2, QXE4, QXE6, QXE8, QXF, QXF2, QXM1, QXQ, QXS, QXS2, QXU, QXW, QXW2, QX2, QX22, QX26, QX4, QX7, RFR, RFR2, RH, RHA, RHA2, RHQ4, RH2, RH26, RMG2, RSK, RTB2, RX, RXE, RXE2, RXE4, RXU, RX4, SAD2, SE, SG24, SH, SHM, SHQ4, SKM, SMC7, SMC9, SMJ, SMJ1, SMW2, SMX4, SM11, SM12, SM14, SNX, SNX1, SSK1, SSK2, SSS2, STA, STM, STP, STQ, SWG4, SWX, SWX2, SWX4, SW2, SX, SXB, SXE, SXE4, SXS4, SXU, SX4, SX7, S1CY, TCS2, TH, THU, TX, TXU, TX2, TX26, TX4, UH, UX, UXU, VA, VA2, VEBM, VEB2, VGE4, VG24, VH, VHA7, VHH4, VHQ4, VIH1, VMB3, VMS4, VMS7, VS, VSD, VSD7, VSX, VSX1, VSX3, VS1, VTD, VTD1, VTU1, VVA, VVA2, VW12, VX, VXE, VXE4, VXE6, VXE7, VVG, VXM, VXU, VXU1, VXX, VXX1, VXX2, VX2, VX26, VX4, WDA6	4575555	QMH
			1	-	-	-			
			-	(1)	-	1			

2

Ref. No.	Part No.	Description	Reqd. QTY				Serial No.	Parts catalogue code	
			GX160K1						
			(1)	(2)	(3)	(4)			
2	17210-ZE1-822	ELEMENT, AIR CLEANER (DUAL) -	1	-	1	-	-----	HG1, HG12, HH, HHQ4, HH26, HX, HXE, HXE2, HXE8, HXQ, HXU, HX2, HX26, HX4, KTA, LAX, LAX2, LH, LHB3, LHQ4, LJS, LSJ, LX, LXU, LX2, LX26, LX4, NW, PH, PHM, PHU, PX, PXU, PX2, QAX, QAX2, QBC2, QBT2, QBT6, QBU2, QCB2, QCL, QE, QFE4, QGR2, QGR9, QH, QHE, QHP1, QHQ4, QH26, QI2, QKA4, QMC8, QMD6, QMX2, QMZ2, QNT, QNT2, QP, QPU, QS2, QWA4, QWM2, QWX2, QWX3, QX, QXB, QXB1, QXE, QXE2, QXE4, QXE6, QXE8, QXF, QXF2, QXM1, QXQ, QXS, QXS2, QXU, QXW, QXW2, QX2, QX22, QX26, QX4, QX7, RFR, RFR2, RH, RHA, RHA2, RHQ4, RH2, RH26, RMG2, RSK, RTB2, RX, RXE, RXE2, RXE4, RXU, RX4, SAD2, SE, SG24, SH, SHM, SHQ4, SKM, SMC7, SMC9, SMJ, SMJ1, SMW2, SMX4, SM11, SM12, SM14, SNX, SNX1, SSK1, SSK2, SSSX2, STA, STM, STP, STQ, SWG4, SWX, SWX2, SWX4, SW2, SX, SXB, SXE, SXE4, SXS4, SXU, SX4, SX7, S1CY, TCS2, TH, THU, TX, TXU, TX2, TX26, TX4, UH, UX, UXU, VA, VA2, VEBM, VEB2, VGE4, VG24, VH, VHA7, VHH4, VHQ4, VIH1, VMB3, VMS4, VMS7, VS, VSD, VSD7, VSX, VSX1, VSX3, VS1, VTD, VTD1, VTU1, VWA, VWA2, VW12, VX, VXE, VXE4, VXE6, VXE7, VXG, VXM, VXU, VXU1, VWX, VWX1, VWX2, VX2, VX26, VX4, WDA6	
			1	-	-	-	4575555	-----	QMH
3	17218-ZE1-821	FILTER, OUTER	1	-	1	-	-----	HG1, HG12, HH, HHQ4, HH26, HX, HXE, HXE2, HXE8, HXQ, HXU, HX2, HX26, HX4, KTA, LAX, LAX2, LH, LHB3, LHQ4, LJS, LSJ, LX, LXU, LX2, LX26, LX4, NW, PH, PHM, PHU, PX, PXU, PX2, QAX, QAX2, QBC2, QBT2, QBT6, QBU2, QCB2, QCL, QE, QFE4, QGR2, QGR9, QH, QHE, QHP1, QHQ4, QH26, QI2, QKA4, QMC8, QMD6, QMX2, QMZ2, QNT, QNT2, QP, QPU, QS2, QWA4, QWM2, QWX2, QWX3, QX, QXB, QXB1, QXE, QXE2, QXE4, QXE6, QXE8, QXF, QXF2, QXM1, QXQ, QXS, QXS2, QXU, QXW, QXW2, QX2, QX22, QX26, QX4, QX7, RFR, RFR2, RH, RHA, RHA2, RHQ4, RH2, RH26, RMG2, RSK, RTB2, RX, RXE, RXE2, RXE4, RXU, RX4, SAD2, SE, SG24, SH, SHM, SHQ4, SKM, SMC7, SMC9, SMJ, SMJ1, SMW2, SMX4, SM11, SM12, SM14, SNX, SNX1, SSK1, SSK2, SSSX2, STA, STM, STP, STQ, SWG4, SWX, SWX2, SWX4, SW2, SX, SXB, SXE, SXE4, SXS4, SXU, SX4, SX7, S1CY, TCS2, TH, THU, TX, TXU, TX2, TX26, TX4, UH, UX, UXU, VA, VA2, VEBM, VEB2, VGE4, VG24, VH, VHA7, VHH4, VHQ4, VIH1, VMB3, VMS4, VMS7, VS, VSD, VSD7, VSX, VSX1, VSX3, VS1, VTD, VTD1, VTU1, VWA, VWA2, VW12, VX, VXE, VXE4, VXE6, VXE7, VXG, VXM, VXU, VXU1, VWX, VWX1, VWX2, VX2, VX26, VX4, WDA6	
			1	-	-	-	4575555	-----	QMH
4	17230-ZE1-820	COVER, AIR CLEANER (DUAL) ...	1	-	1	-	-----	HG1, HG12, HH, HHQ4, HH26, HX, HXE, HXE2, HXE8, HXQ, HXU, HX2, HX26, HX4, KTA, LAX, LAX2, LH, LHB3, LHQ4, LJS, LSJ, LX, LXU, LX2, LX26, LX4, NW, PH, PHM, PHU, PX, PXU, PX2, QAX, QAX2, QBC2, QBT2, QBT6, QBU2, QCB2, QCL, QE, QFE4, QGR2, QGR9, QH, QHE, QHP1, QHQ4, QH26, QI2, QKA4, QMC8, QMD6, QMX2, QMZ2, QNT, QNT2, QP, QPU, QS2, QWA4, QWM2, QWX2, QWX3, QX, QXB, QXB1, QXE, QXE2, QXE4, QXE6, QXE8, QXF, QXF2, QXM1, QXQ, QXS, QXS2, QXU, QXW, QXW2, QX2, QX22, QX26, QX4, QX7, RFR, RFR2, RH, RHA, RHA2, RHQ4, RH2, RH26, RMG2, RSK, RTB2, RX, RXE, RXE2, RXE4, RXU, RX4, SAD2, SE, SG24, SH, SHM, SHQ4, SKM, SMC7, SMC9, SMJ, SMJ1, SMW2, SMX4, SM11, SM12, SM14, SNX, SNX1, SSK1, SSK2, SSSX2, STA, STM, STP, STQ, SWG4, SWX, SWX2, SWX4, SW2, SX, SXB, SXE, SXE4, SXS4, SXU, SX4, SX7, S1CY, TCS2, TH, THU, TX, TXU, TX2, TX26, TX4, UH, UX, UXU, VA, VA2, VEBM, VEB2, VGE4, VG24, VH, VHA7, VHH4, VHQ4, VIH1, VMB3, VMS4, VMS7, VS, VSD, VSD7, VSX, VSX1, VSX3, VS1, VTD, VTD1, VTU1, VWA, VWA2, VW12, VX, VXE, VXE4, VXE6, VXE7, VXG, VXM, VXU, VXU1, VWX, VWX1, VWX2, VX2, VX26, VX4, WDA6	
			1	-	-	-	4575555	-----	QMH



E-15

AIR CLEANER(1)

N 3

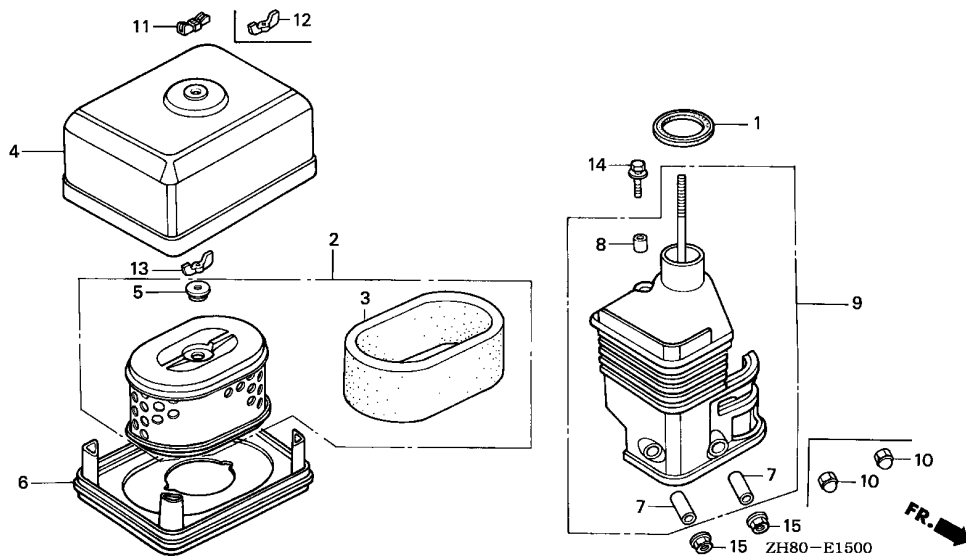

2

Ref. No.	Part No.	Description	Reqd. QTY				Serial No.	Parts catalogue code
			(1)	(2)	(3)	(4)		
5	17232-891-000	GROMMET, AIR CLEANER	1	-	1	-	-----	HG1, HG12, HH, HHQ4, HH26, HX, HXE, HXE2, HXE8, HXQ, HXU, HX2, HX26, HX4, KTA, LAX, LAX2, LH, LHB3, LHQ4, LJS, LSJ, LX, LXU, LX2, LX26, LX4, NW, PH, PHM, PHU, PX, PXU, PX2, QAX, QAX2, QBC2, QBT2, QBT6, QBU2, QCB2, QCL, QE, QFE4, QGR2, QGR9, QH, QHE, QHP1, QHQ4, QH26, QI2, QKA4, QMC8, QMD6, QMX2, QMZ2, QNT, QNT2, QP, QPU, QS2, QWA4, QWM2, QWX2, QWX3, QX, QXB, QXB1, QXE, QXE2, QXE4, QXE6, QXE8, QXF, QXF2, QXM1, QXQ, QXS, QXS2, QXU, QXW, QXW2, QX2, QX22, QX26, QX4, QX7, RFR, RFR2, RH, RHA, RHA2, RHQ4, RH2, RH26, RMG2, RSK, RTB2, RX, RXE, RXE2, RXE4, RXU, RX4, SAD2, SE, SG24, SH, SHM, SHQ4, SKM, SMC7, SMC9, SMJ, SMJ1, SMW2, SMX4, SM11, SM12, SM14, SNX, SNX1, SSK1, SSK2, SSS2, STA, STM, STP, STQ, SWG4, SWX, SWX2, SWX4, SW2, SX, SXB, SXE, SXE4, SXS4, SXU, SX4, SX7, S1CY, TCS2, TH, THU, TX, TXU, TX2, TX26, TX4, UH, UX, UXU, VA, VA2, VEBM, VEB2, VGE4, VG24, VH, VHA7, VHH4, VHQ4, VIH1, VMB3, VMS4, VMS7, VS, VSD, VSD7, VSX, VSX1, VSX3, VS1, VTD, VTD1, VTU1, VVA, VVA2, VW12, VX, VXE, VXE4, VXE6, VXE7, VXG, VXM, VXU, VXU1, VXX, VXX1, VXX2, VX2, VX26, VX4, WDA6
			1	-	-	-	4575555 -----	QMH
			-	(1)	-	1		
6	17235-ZE1-831	NOSE, SILENCER	1	-	-	-	-----	KTA, QBC2, QBT2, QBU2, QE, QFE4, QMC8, QMD6, QMX2, QMZ2, QNT, QNT2, QWA4, QWM2, QWX2, QX7, RTB2, SAD2, SE, SG24, SKM, SMC7, SMC9, SM11, SM12, SSK1, SSK2, SSS2, STA, STP, STQ, SWG4, SX7, S1CY, VEBM, VEB2, VG24, VHA7, VMB3, VMS4, VMS7, VSD7, VXE7
			-	(1)	-	-		

Ref. No.	Part No.	Description	Reqd. QTY				Serial No.	Parts catalogue code
			(1)	(2)	(3)	(4)		
7	17238-ZE7-010	COLLAR, AIR CLEANER	2	-	2	-	-----	HG1, HG12, HH, HHQ4, HH26, HX, HXE, HXE2, HXE8, HXQ, HXU, HX2, HX26, HX4 KTA, LAX, LAX2, LH, LHB3, LHQ4, LJS, LSJ, LX, LXU, LX2, LX26, LX4, NW, PH PHM, PHU, PX, PXU, PX2, QAX, QAX2, QBC2, QBT2, QBT6, QBU2, QCB2, QCL, QE QFE4, QGR2, QGR9, QH, QHE, QHP1, QHQ4, QH26, QI2, QKA4, QMC8, QMD6, QMX2 QMZ2, QNT, QNT2, QP, QPU, QS2, QWA4, QWM2, QWX2, QWX3, QX, QXB, QXB1, QXE QXE2, QXE4, QXE6, QXE8, QXF, QXF2, QXM1, QXQ, QXS, QXS2, QXU, QXW, QXW2 QX2, QX22, QX26, QX4, QX7, RFR, RFR2, RH, RHA, RHA2, RHQ4, RH2, RH26, RMG2 RSK, RTB2, RX, RXE, RXE2, RXE4, RXU, RX4, SAD2, SE, SG24, SH, SHM, SHQ4, SKM SMC7, SMC9, SMJ, SMJ1, SMW2, SMX4, SM11, SM12, SM14, SNX, SNX1, SSK1, SSK2 SSX2, STA, STM, STP, STQ, SWG4, SWX, SWX2, SWX4, SW2, SX, SXB, SXE, SXE4 SXS4, SXU, SX4, SX7, S1CY, TCS2, TH, THU, TX, TXU, TX2, TX26, TX4, UH, UX UXU, VA, VA2, VEBM, VEB2, VGE4, VG24, VH, VHA7, VHH4, VHQ4, VIH1, VMB3 VMS4, VMS7, VS, VSD, VSD7, VSX, VSX1, VSX3, VS1, VTD, VTD1, VTU1, VWA, VWA2 VW12, VX, VXE, VXE4, VXE6, VXE7, VVG, VXM, VXU, VXU1, VWX, VWX1, VWX2, VX2 VX26, VX4, WDA6
			2	-	-	-	4575555 -----	QMH
8	17239-ZE1-000	COLLAR B, AIR CLEANER	1	-	1	-	-----	HG1, HG12, HH, HHQ4, HH26, HX, HXE, HXE2, HXE8, HXQ, HXU, HX2, HX26, HX4 KTA, LAX, LAX2, LH, LHB3, LHQ4, LJS, LSJ, LX, LXU, LX2, LX26, LX4, NW, PH PHM, PHU, PX, PXU, PX2, QAX, QAX2, QBC2, QBT2, QBT6, QBU2, QCB2, QCL, QE QFE4, QGR2, QGR9, QH, QHE, QHP1, QHQ4, QH26, QI2, QKA4, QMC8, QMD6, QMX2 QMZ2, QNT, QNT2, QP, QPU, QS2, QWA4, QWM2, QWX2, QWX3, QX, QXB, QXB1, QXE QXE2, QXE4, QXE6, QXE8, QXF, QXF2, QXM1, QXQ, QXS, QXS2, QXU, QXW, QXW2 QX2, QX22, QX26, QX4, QX7, RFR, RFR2, RH, RHA, RHA2, RHQ4, RH2, RH26, RMG2 RSK, RTB2, RX, RXE, RXE2, RXE4, RXU, RX4, SAD2, SE, SG24, SH, SHM, SHQ4, SKM SMC7, SMC9, SMJ, SMJ1, SMW2, SMX4, SM11, SM12, SM14, SNX, SNX1, SSK1, SSK2 SSX2, STA, STM, STP, STQ, SWG4, SWX, SWX2, SWX4, SW2, SX, SXB, SXE, SXE4 SXS4, SXU, SX4, SX7, S1CY, TCS2, TH, THU, TX, TXU, TX2, TX26, TX4, UH, UX UXU, VA, VA2, VEBM, VEB2, VGE4, VG24, VH, VHA7, VHH4, VHQ4, VIH1, VMB3 VMS4, VMS7, VS, VSD, VSD7, VSX, VSX1, VSX3, VS1, VTD, VTD1, VTU1, VWA, VWA2 VW12, VX, VXE, VXE4, VXE6, VXE7, VVG, VXM, VXU, VXU1, VWX, VWX1, VWX2, VX2 VX26, VX4, WDA6
			1	-	-	-	4575555 -----	QMH
9	17410-ZE1-020	ELBOW COMP., AIR CLEANER	1	-	1	-	-----	HG1, HG12, HH, HHQ4, HH26, HX, HXE, HXE2, HXE8, HXQ, HXU, HX2, HX26, HX4 KTA, LAX, LAX2, LH, LHB3, LHQ4, LJS, LSJ, LX, LXU, LX2, LX26, LX4, NW, PH PHM, PHU, PX, PXU, PX2, QAX, QAX2, QBC2, QBT2, QBT6, QBU2, QCB2, QCL, QE QFE4, QGR2, QGR9, QH, QHE, QHP1, QHQ4, QH26, QI2, QKA4, QMC8, QMD6, QMX2 QMZ2, QNT, QNT2, QP, QPU, QS2, QWA4, QWM2, QWX2, QWX3, QX, QXB, QXB1, QXE QXE2, QXE4, QXE6, QXE8, QXF, QXF2, QXM1, QXQ, QXS, QXS2, QXU, QXW, QXW2 QX2, QX22, QX26, QX4, QX7, RFR, RFR2, RH, RHA, RHA2, RHQ4, RH2, RH26, RMG2 RSK, RTB2, RX, RXE, RXE2, RXE4, RXU, RX4, SAD2, SE, SG24, SH, SHM, SHQ4, SKM SMC7, SMC9, SMJ, SMJ1, SMW2, SMX4, SM11, SM12, SM14, SNX, SNX1, SSK1, SSK2 SSX2, STA, STM, STP, STQ, SWG4, SWX, SWX2, SWX4, SW2, SX, SXB, SXE, SXE4 SXS4, SXU, SX4, SX7, S1CY, TCS2, TH, THU, TX, TXU, TX2, TX26, TX4, UH, UX UXU, VA, VA2, VEBM, VEB2, VGE4, VG24, VH, VHA7, VHH4, VHQ4, VIH1, VMB3 VMS4, VMS7, VS, VSD, VSD7, VSX, VSX1, VSX3, VS1, VTD, VTD1, VTU1, VWA, VWA2 VW12, VX, VXE, VXE4, VXE6, VXE7, VVG, VXM, VXU, VXU1, VWX, VWX1, VWX2, VX2 VX26, VX4, WDA6
			1	-	-	-	4575555 -----	QMH
10	90201-415-000	NUT, CAP, 6MM	2	-	-	-	-----	HXQ, HX2, LX2, PX2, QXE2, QXF2, QXQ, QXS2, QX2, RH2, TX2, VXW2, VX2
			2	-	-	-	2708121 -----	HH, KTA, LH, LJS, LX, PH, PX, QE, QH, QHE, QNT, QXB, QXW, RX, RXE, SE, SH, SKM SMJ, SMJ1, STA, STP, STQ, SWX, SW2, SX, SXB, SXE, TH, UH, UX, VA, VEBM, VH, VS VSD, VSX, VSX1, VS1, VXE
			2	-	-	-	2709371 -----	HG1, HX, QX, QXE, QXF, QXS, RFR, RH, TX, VWA, VX, VXW
			-	2	-	-	2708121 -----	



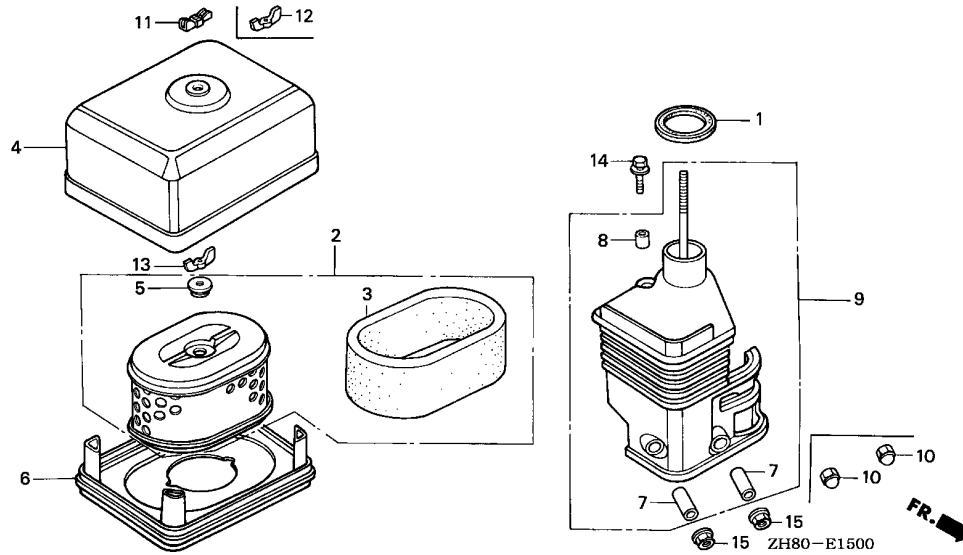

Ref. No.	Part No.	Description	Reqd. QTY				Serial No.	Parts catalogue code
			(1)	(2)	(3)	(4)		
				GX160K1				
11	90203-PB2-000	NUT, AIR CLEANER COVER (DACRO COATING)	1	-	-	-	2468252	HH, HX, LH, LJS, LX, PH, PX, QE, QH, QHE, QNT, QX, QXE, QXF, QXS, RH, RX, RXE, SE, SH, SKM, SMJ, SMJ1, STA, STP, STQ, SWX, SW2, SX, SXE, TH, TX, UH, UX, VA, VEBM, VH, VS, VSD, VSX, VX, VXE, VXW
	90203-ZA0-800	NUT, WING, 6MM(BLACK)	1	(1)	-	-	2468252	HG1, HXQ, HX2, KTA, LX2, PX2, QXB, QXE2, QXF2, QXQ, QXS2, QXW, QX2, RFR, RH2, RSK, SXB, TX2, VSX1, VS1, VWA, VXW2, VX2
			1	-	-	-	2468253	2836833 HH, HX, LH, LJS, LX, PH, PX, QE, QH, QHE, QNT, QX, QXE, QXF, QXS, RH, RX, RXE, SE, SH, SKM, SMJ, SMJ1, STA, STP, STQ, SWX, SW2, SX, SXE, TH, TX, UH, UX, VA, VEBM, VH, VS, VSD, VSX, VX, VXE, VXW
			-	(1)	-	-	2468253	2836833

Ref. No.	Part No.	Description	Reqd. QTY				Serial No.	Parts catalogue code
			(1)	GX160K1 (2)	(3)	(4)		
12	90325-044-000	NUT, TOOL BOX SETTING	1	-	1	-	-----	HG12,HHQ4,HH26,HXE,HXE2,HXE8,HXU,HX26,HX4,LAX,LAX2,LHB3,LHQ4,LSJ,LXU,LX26,LX4,NW,PHM,PHU,PXU,QAX,QAX2,QBC2,QBT2,QBT6,QBU2,QCB2,QCL,QFE4,QGR2,QGR9,QHP1,QHQ4,QH26,QI2,QKA4,QMC8,QMD6,QMZ2,QMZ2,QNT2,QP,QPU,QS2,QWA4,QWM2,QWX2,QWX3,QXB1,QXE4,QXE6,QXE8,QXM1,QXU,QXW2,QX22,QX26,QX4,QX7,RFR2,RHA,RHA2,RHQ4,RH26,RMG2,RTB2,RXE2,RXE4,RXU,RX4,SAD2,SG24,SHM,SHQ4,SMC7,SMC9,SMW2,SMX4,SM11,SM12,SM14,SNX,SNX1,SSK1,SSK2,SSX2,STM,SWG4,SWX2,SWX4,SXE4,SXS4,SXU,SX4,SX7,S1CY,TCS2,THU,TXU,TX26,TX4,UXU,VA2,VEB2,VGE4,VG24,VHA7,VHH4,VHQ4,VIH1,VMB3,VMS4,VMS7,VSD7,VSX3,VTD,VTD1,VTU1,VWA2,VW12,VXE4,VXE6,VXE7,VXG,VXM,VXU,VXU1,VXW1,VX26,VX4,WDA6
			1	-	-	-	2836834 -----	HG1,HH,HX,HXQ,HX2,KTA,LH,LJS,LX,LX2,PH,PX,PX2,QE,QH,QHE,QNT,QX,QXB,QXE,QXE2,QXF,QXF2,QXQ,QXS,QXS2,QXW,QX2,RFR,RH,RH2,RSK,RXRXE,SE,SH,SKM,SMJ,SMJ1,STA,STP,STQ,SWX,SW2,SX,SXB,SXE,TH,TX,TX2,UH,UX,VA,VEBM,VH,VS,VSD,VSX,VSX1,VS1,VWA,VX,VXE,VXW,VXW2,VX2
			1	-	-	-	4575555 -----	QMH
			-	(1)	-	-	2836834	
			-	-	-	1		
13	90325-044-000	NUT, TOOL BOX SETTING	1	-	1	-	-----	HG1,HG12,HH,HHQ4,HH26,HX,HXE,HXE2,HXE8,HXQ,HXU,HX2,HX26,HX4,KTA,LAX,LAX2,LH,LHB3,LHQ4,LJS,LSJ,LX,LXU,LX2,LX26,LX4,NW,PH,PHM,PHU,PX,PXU,PX2,QAX,QAX2,QBC2,QBT2,QBT6,QBU2,QCB2,QCL,QE,QFE4,QGR2,QGR9,QH,QHE,QHP1,QHQ4,QH26,QI2,QKA4,QMC8,QMD6,QMZ2,QMZ2,QNT,QNT2,QP,QPU,QS2,QWA4,QWM2,QWX2,QWX3,QX,QXB,QXB1,QXE,QXE2,QXE4,QXE6,QXE8,QXF,QXF2,QXM1,QXQ,QXS,QXS2,QXU,QXW,QXW2,QX2,QX22,QX26,QX4,QX7,RFR,RFR2,RH,RHA,RHA2,RHQ4,RH2,RH26,RMG2,RSK,RTB2,RX,RXE,RXE2,RXE4,RXU,RX4,SAD2,SE,SG24,SH,SHM,SHQ4,SKM,SMC7,SMC9,SMJ,SMJ1,SMW2,SMX4,SM11,SM12,SM14,SNX,SNX1,SSK1,SSK2,SSX2,STA,STM,STP,STQ,SWG4,SWX,SWX2,SWX4,SW2,SX,SXB,SXE,SXE4,SXS4,SXU,SX4,SX7,S1CY,TCS2,TH,THU,TX,TXU,TX2,TX26,TX4,UH,UX,UXU,VA,VA2,VEBM,VEB2,VGE4,VG24,VH,VHA7,VHH4,VHQ4,VIH1,VMB3,VMS4,VMS7,VS,VSD,VSD7,VSX,VSX1,VSX3,VS1,VTD,VTD1,VTU1,VWA,VWA2,VW12,VX,VXE,VXE4,VXE6,VXE7,VXG,VXM,VXU,VXU1,VXW,VXW1,VXW2,VX2,VX26,VX4,WDA6
			1	-	-	-	4575555 -----	QMH
			-	(1)	-	1		
14	93494-06020-08	BOLT-WASHER, 6X20	1	-	-	-	-----	HG1,HH,HX,HXU,LH,LJS,LX,LXU,PH,PX,PXU,QE,QH,QHE,QX,QXB1,QXE,QXE8,QXF,QXS,QXU,RH,RX,RXE,RXU,SE,SH,STA,STP,STQ,SWX,SW2,SX,SXE,SXU,TH,TX,TXU,UH,UX,UXU,VA,VEBM,VH,VS,VSX,VX,VXE,VXW
	93404-06020-08	1	-	-	-	3385101 -----	HHQ4,HXQ,HX2,HX4,KTA,LAX,LHQ4,LX2,LX4,PHU,PX2,QAX,QGR2,QHQ4,QNT,QXB,QXE2,QXE4,QXF2,QXQ,QXS2,QXW,QX2,QX4,RFR,RHA,RHQ4,RH2,RSK,RXE4,RX4,SHQ4,SKM,SMJ,SMJ1,SNX,SSK1,SXB,SXE4,SX4,THU,TX2,TX4,VHQ4,VSD,VSX1,VS1,VWA,VXE4,VXG,VXU,VXW1,VXW2,VX2,VX4



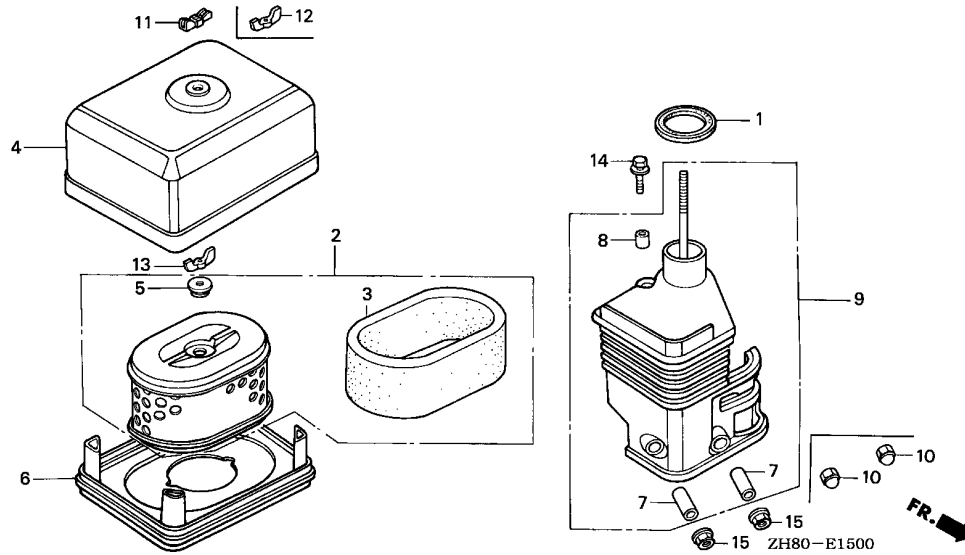

Ref. No.	Part No.	Description	Reqd. QTY				Serial No.	Parts catalogue code
			(1)	(2)	(3)	(4)		
14)	95701-06020-00	BOLT, FLANGE, 6X20	1	-	1	-		HG12,HH26,HXE,HXE2,HXE8,HX26,LAX2,LHB3,LSJ,LX26,NW,PHM,QAX2,QBC2,QBT2,QBT6,QBU2,QCB2,QCL,QFE4,QGR9,QHP1,QH26,QI2,QKA4,QMC8,QMD6,QMX2,QMZ2,QNT2,QP,QPU,QS2,QWA4,QWM2,QWX2,QWX3,QXE6,QXM1,QXW2,QX22,QX26,QX7,RFR2,RHA2,RH26,RMG2,RTB2,RXE2,SAD2,SG24,SHM,SMC7,SMC9,SMW2,SMX4,SM11,SM12,SM14,SNX1,SSK2,SSX2,STM,SWG4,SWX2,SWX4,SXS4,SX7,S1CY,TCS2,TX26,VA2,VEB2,VG24,VHA7,VHH4,VIH1,VMB3,VMS4,VMS7,VSD7,VSX3,VTD,VTD1,VTU1,VWA2,VW12,VXE6,VXE7,VXM,VXU1,VX26,WDA6
			1	-	-	-	3385102	HHQ4,HXQ,HX2,HX4,KTA,LAX,LHQ4,LX2,LX4,PHU,PX2,QAX,QGR2,QHQ4,QNT,QXB,QXE2,QXE4,QXF2,QXQ,QXS2,QXW,QX2,QX4,RFR,RHA,RHQ4,RH2,RSK,RXE4,RX4,SHQ4,SKM,SMJ,SMJ1,SNX,SSK1,SXB,SXE4,SX4,THU,TX2,TX4,VHQ4,VSD,VSX1,VS1,VWA,VXE4,VXG,VXU,VXW1,VXW2,VX2,VX4
			1	-	-	-	4575555	QMH
			-	-	-	1		

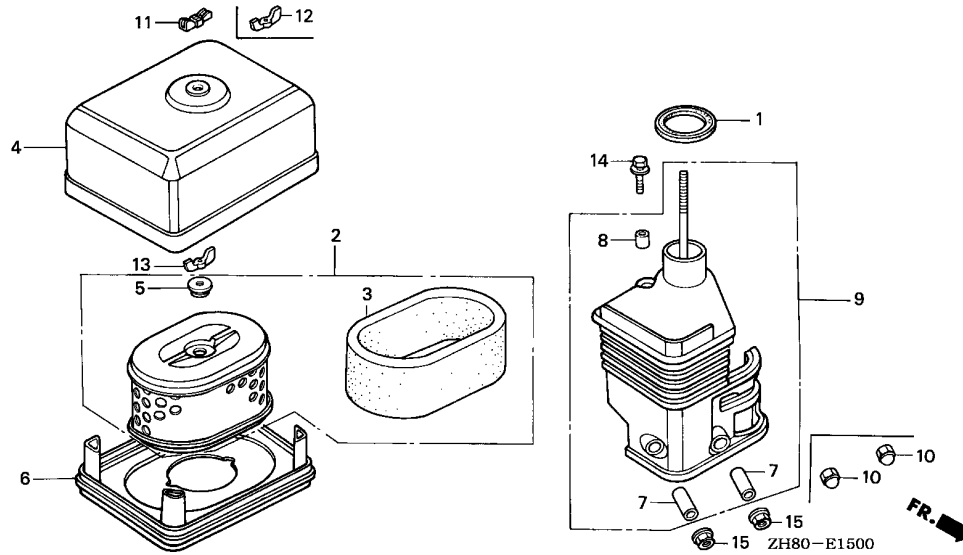

Ref. No.	Part No.	Description	Reqd. QTY				Serial No.	Parts catalogue code
			(1)	(2)	(3)	(4)		
15	94050-06000	NUT, FLANGE, 6MM	1	-	-	-	QGR2	
			2	-	2	-	HG12, HHQ4, HH26, HXE, HXE2, HXE8, HXU, HX26, HX4, LAX, LAX2, LHB3, LHQ4, LSJ, LXU, LX26, LX4, NW, PHM, PHU, PXU, QAX, QAX2, QBC2, QBT2, QBT6, QBU2, QCB2, QCL, QFE4, QGR9, QHP1, QHQ4, QH26, QI2, QKA4, QMC8, QMD6, QMX2, QMZ2, QNT2, QP, QPU, QS2, QWA4, QWM2, QWX2, QWX3, QXB1, QXE4, QXE6, QXE8, QXM1, QXU, QXW2, QX22, QX26, QX4, QX7, RFR2, RHA, RHA2, RHQ4, RH26, RMG2, RSK, RTB2, RXE2, RXE4, RXU, RX4, SAD2, SG24, SHM, SHQ4, SMC7, SMC9, SMW2, SMX4, SM11, SM12, SM14, SNX, SNX1, SSK1, SSK2, SSX2, STM, SWG4, SWX2, SWX4, SXE4, SXS4, SXU, SX4, SX7, S1CY, TCS2, THU, TXU, TX26, TX4, UXU, VA2, VEB2, VGE4, VG24, VHA7, VHH4, VHQ4, VIH1, VMB3, VMS4, VMS7, VSD7, VSX3, VTD, VTD1, VTU1, VWA2, VW12, VXE4, VXE6, VXE7, VXG, VXM, VXU, VXU1, VXW1, VX26, VX4, WDA6	
			2	-	-	2708122	HH, KTA, LH, LJS, LX, PH, PX, QE, QH, QHE, QNT, QXB, QXW, RX, RXE, SE, SH, SKM, SMJ, SMJ1, STA, STP, STQ, SWX, SW2, SX, SXB, SXE, TH, UH, UX, VA, VEBM, VH, VS, VSD, VSX, VSX1, VS1, VXE	
			2	-	-	2709372	VWA	
			2	-	-	4575555	QMH	
			2	-	-	2709372	HG1, HX, QX, QXE, QXF, QXS, RFR, RH, TX, VX, VXW	
			-	2	-	2708122		
			-	-	-	2		

E-15-1

AIR CLEANER(2)

N 9

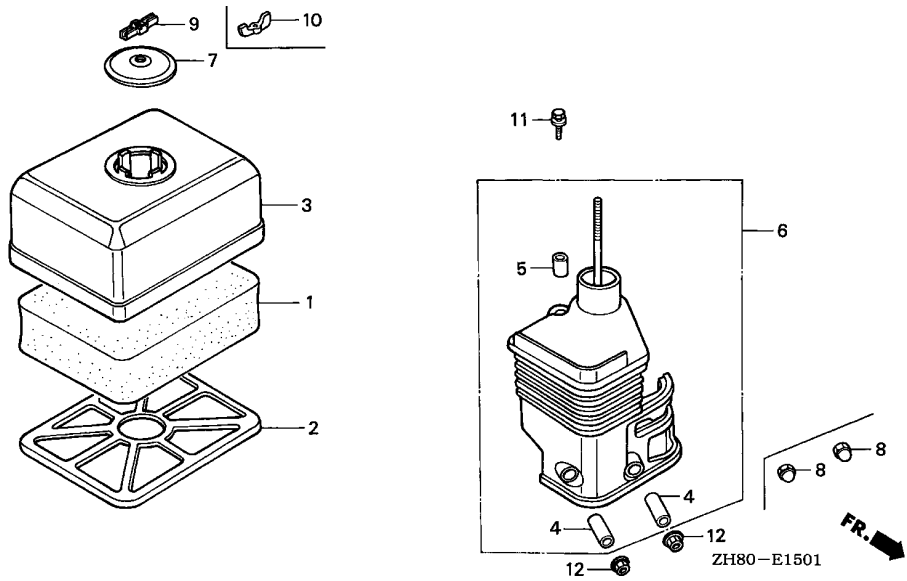

Ref. No.	L.O.N.	(Relative ref. Number) Description	F.R.T.
1	3121B8	ELEMENT, AIR CLEANER	0.1
6	3121B4	ELBOW, AIR CLEANER	0.1

2

Ref. No.	Part No.	Description	Reqd. QTY				Serial No.	Parts catalogue code
			(1)	(2)	(3)	(4)		
1	17211-ZE1-000	ELEMENT, AIR CLEANER (SEMI DRY)	1	-	1	-	-----	DS,DSP,EN,ET,ETX,LD,LDB1,LDB3,LDM,LD4,LJ,LJC7,LJD,LJG,LSJ4,LSS LSS1,LTA,NJ,NJG,NSJ,PM,PM2,QD,QM,QMC6,QNZ,RD,RD4,RMD,RNG,RSS1 SCJ,SD,SDB1,SDB3,SDN,SDS,SDS2,SD16,SD4,SEE,SHRY,SHR4,SJ,SJC SJC1,SJC5,SJG,ST,UIH,VED,VED1,VED5,VED6,VXD,VXD1,WIH1,WJP,WKD6 WKT2,WKT4,WKT6,WMB0,WME2,WME4,WMT
2	17212-ZE1-000	GRID, AIR CLEANER (SEMI DRY)	-	(1)	-	-	-----	DS,DSP,EN,ET,ETX,LD,LDB1,LDB3,LDM,LD4,LJ,LJC7,LJD,LJG,LSJ4,LSS LSS1,LTA,NJ,NJG,NSJ,PM,PM2,QD,QM,QMC6,QNZ,RD,RD4,RMD,RNG,RSS1 SCJ,SD,SDB1,SDB3,SDN,SDS,SDS2,SD16,SD4,SEE,SHRY,SHR4,SJ,SJC SJC1,SJC5,SJG,ST,UIH,VED,VED1,VED5,VED6,VXD,VXD1,WIH1,WJP,WKD6 WKT2,WKT4,WKT6,WMB0,WME2,WME4,WMT
3	17231-ZE1-000	COVER, AIR CLEANER (SEMI DRY)	1	-	1	-	-----	DS,DSP,EN,ET,ETX,LD,LDB1,LDB3,LDM,LD4,LJ,LJC7,LJD,LJG,LSJ4,LSS LSS1,LTA,NJ,NJG,NSJ,PM,PM2,QD,QM,QMC6,QNZ,RD,RD4,RMD,RNG,RSS1 SCJ,SD,SDB1,SDB3,SDN,SDS,SDS2,SD16,SD4,SEE,SHRY,SHR4,SJ,SJC SJC1,SJC5,SJG,ST,UIH,VED,VED1,VED5,VED6,VXD,VXD1,WIH1,WJP,WKD6 WKT2,WKT4,WKT6,WMB0,WME2,WME4,WMT
4	17238-ZE7-010	COLLAR, AIR CLEANER	2	-	2	-	-----	DS,DSP,EN,ET,ETX,LD,LDB1,LDB3,LDM,LD4,LJ,LJC7,LJD,LJG,LSJ4,LSS LSS1,LTA,NJ,NJG,NSJ,PM,PM2,QD,QM,QMC6,QNZ,RD,RD4,RMD,RNG,RSS1 SCJ,SD,SDB1,SDB3,SDN,SDS,SDS2,SD16,SD4,SEE,SHRY,SHR4,SJ,SJC SJC1,SJC5,SJG,ST,UIH,VED,VED1,VED5,VED6,VXD,VXD1,WIH1,WJP,WKD6 WKT2,WKT4,WKT6,WMB0,WME2,WME4,WMT
			-	(2)	-	-	-----	

E-15-1

AIR CLEANER(2)

N10

Ref. No.	Part No.	Description	Reqd. QTY				Serial No.	Parts catalogue code
			(1)	(2)	(3)	(4)		
5	17239-ZE1-000	COLLAR B, AIR CLEANER	1	-	1	-	DS,DSP,EN,ET,ETX,LD,LDB1,LDB3,LDM,LD4,LJ,LJC7,LJD,LJG,LSJ4,LSS1,LSS1,LTA,NJ,NJG,NSJ,PM,PM2,QD,QM,QMC6,QNZ,RD,RD4,RMD,RNG,RSS1,SCJ,SD,SDB1,SDB3,SDN,SDS,SDS2,SD16,SD4,SEE,SHRY,SHR4,SJ,SJC,SJC1,SJC5,SJG,ST,UIH,VED,VED1,VED5,VED6,VXD,VXD1,WIH1,WJP,WKD6,WKT2,WKT4,WKT6,WMB0,WME2,WME4,WMT	
			-	(1)	-	-		
6	17410-ZE1-020	ELBOW COMP., AIR CLEANER	1	-	1	-	DS,DSP,EN,ET,ETX,LD,LDB1,LDB3,LDM,LD4,LJ,LJC7,LJD,LJG,LSJ4,LSS1,LSS1,LTA,NJ,NJG,NSJ,PM,PM2,QD,QM,QMC6,QNZ,RD,RD4,RMD,RNG,RSS1,SCJ,SD,SDB1,SDB3,SDN,SDS,SDS2,SD16,SD4,SEE,SHRY,SHR4,SJ,SJC,SJC1,SJC5,SJG,ST,UIH,VED,VED1,VED5,VED6,VXD,VXD1,WIH1,WJP,WKD6,WKT2,WKT4,WKT6,WMB0,WME2,WME4,WMT	
			-	(1)	-	-		
7	17421-ZE1-000	CAP, CLEANER	1	-	1	-	DS,DSP,EN,ET,ETX,LD,LDB1,LDB3,LDM,LD4,LJ,LJC7,LJD,LJG,LSJ4,LSS1,LSS1,LTA,NJ,NJG,NSJ,PM,PM2,QD,QM,QMC6,QNZ,RD,RD4,RMD,RNG,RSS1,SCJ,SD,SDB1,SDB3,SDN,SDS,SDS2,SD16,SD4,SEE,SHRY,SHR4,SJ,SJC,SJC1,SJC5,SJG,ST,UIH,VED,VED1,VED5,VED6,VXD,VXD1,WIH1,WJP,WKD6,WKT2,WKT4,WKT6,WMB0,WME2,WME4,WMT	
			-	(1)	-	-		
8	90201-415-000	NUT, CAP, 6MM	2	-	-	-	2708121 DS,DSP,EN,ET,ETX,LD,LJ,LTA,PM,PM2,QD,QM,RD,SCJ,SD,SDS,SEE,SJ,ST,VED,VED1	
			-	2	-	-	2708121	
9	90203-PB2-000	NUT, AIR CLEANER COVER (DACRO COATING)	1	-	-	-	2468252 DS,DSP,EN,ET,ETX,LD,LJ,LTA,PM,PM2,QD,QM,RD,SD,SDS,SEE,SJ,ST,VED,VED1	
			-	(1)	-	-	2468252	
	90203-ZA0-800	NUT, WING, 6MM(BLACK)	1	-	-	-	2438253 SCJ	
			1	-	-	-	2468253 DS,DSP,EN,ET,ETX,LD,LJ,LTA,PM,PM2,QD,QM,RD,SD,SDS,SEE,SJ,ST,VED,VED1	
			-	(1)	-	-	2468253 2836833	
10	90325-044-000	NUT, TOOL BOX SETTING	1	-	1	-	LDB1,LDB3,LDM,LD4,LJC7,LJD,LJG,LSJ4,LSS,LSS1,NJ,NJG,NSJ,QMC6,QNZ,RD4,RMD,RNG,RSS1,SDB1,SDB3,SDN,SDS2,SD16,SD4,SHRY,SHR4,SJC,SJC1,SJC5,SJG,UIH,VED5,VED6,VXD,VXD1,WIH1,WJP,WKD6,WKT2,WKT4,WKT6,WMB0,WME2,WME4,WMT	
			1	-	-	-	2836834 DS,DSP,EN,ET,ETX,LD,LJ,LTA,PM,PM2,QD,QM,RD,SCJ,SD,SDS,SEE,SJ,ST,VED,VED1	
			-	(1)	-	-	2836834	
11	93404-06020-08	BOLT-WASHER, 6X20	1	-	-	-	3385101 EN,ET,ETX,LD4,LJD,LJG,QNZ,RD4,RMD,SCJ,SDB1,SD4,SJG,VED,VED1,WJP,WMT	
	93494-06020-08	1	-	1	-	DS,DSP,LD,LJ,LTA,PM,PM2,QD,QM,RD,SD,SDS,SEE,SJ,ST,UIH	
			-	(1)	-	-		
	95701-06020-00	BOLT, FLANGE, 6X20	1	-	1	-	LDB1,LDB3,LDM,LJC7,LSJ4,LSS,LSS1,NJ,NJG,NSJ,QMC6,RNG,RSS1,SDB3,SDN,SDS2,SD16,SHRY,SHR4,SJC,SJC1,SJC5,VED5,VED6,VXD,VXD1,WIH1,WKD6,WKT2,WKT4,WKT6,WMB0,WME2,WME4	
			1	-	-	-	3385102 EN,ET,ETX,LD4,LJD,LJG,QNZ,RD4,RMD,SCJ,SDB1,SD4,SJG,VED,VED1,WJP,WMT	
12	94050-06000	NUT, FLANGE, 6MM	2	-	2	-	LDB1,LDB3,LDM,LD4,LJC7,LJD,LJG,LSJ4,LSS,LSS1,NJ,NJG,NSJ,QMC6,QNZ,RD4,RMD,RNG,RSS1,SDB1,SDB3,SDN,SDS2,SD16,SD4,SHRY,SHR4,SJC,SJC1,SJC5,SJG,UIH,VED5,VED6,VXD,VXD1,WIH1,WJP,WKD6,WKT2,WKT4,WKT6,WMB0,WME2,WME4,WMT	
			2	-	-	-	2708122 DS,DSP,EN,ET,ETX,LD,LJ,LTA,PM,PM2,QD,QM,RD,SCJ,SD,SDS,SEE,SJ,ST,VED,VED1	
			-	(2)	-	-	2708122	

2

E-15-2

AIR CLEANER(3)

N11

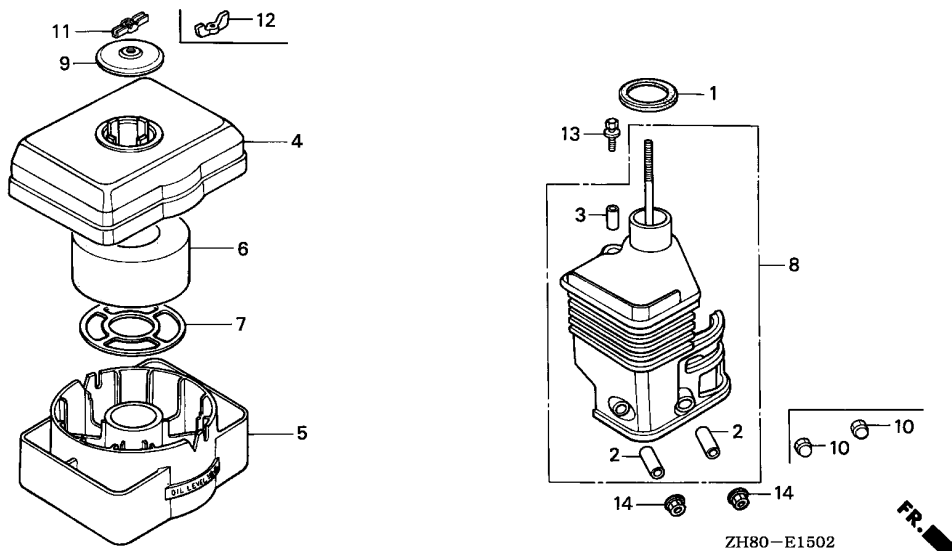

Ref. No.	L.O.N.	(Relative ref. Number) Description	F.R.T.
5	3121E5	PAN, AIR CLEANER OIL	0.1
6	3121B8	ELEMENT, AIR CLEANER	0.1
8	3121B4	ELBOW, AIR CLEANER	0.1

2

Ref. No.	Part No.	Description	Reqd. QTY				Serial No.	Parts catalogue code
			(1)	GX160K1 (2)	(3)	(4)		
1	16271-ZE1-000	PACKING, ELBOW	1	-	1	-	BL,LHW,LMT,LTK,LVL,LW2,QA,QAB1,QAB3,QA2,QA26,QIH1,QME4,QT,QVL RAC,RMB4,SAC,SDS3,SMB4,STM 4575554 QMH	
2	17238-ZE7-010	COLLAR, AIR CLEANER	2	-	2	-	BL,LHW,LMT,LTK,LVL,LW2,QA,QAB1,QAB3,QA2,QA26,QIH1,QME4,QT,QVL RAC,RMB4,SAC,SDS3,SMB4,STM 4575554 QMH	
3	17239-ZE1-000	COLLAR B, AIR CLEANER	1	-	1	-	BL,LHW,LMT,LTK,LVL,LW2,QA,QAB1,QAB3,QA2,QA26,QIH1,QME4,QT,QVL RAC,RMB4,SAC,SDS3,SMB4,STM 4575554 QMH	
4	17401-ZE1-810	BODY, CLEANER (OIL BATH)	1	-	1	-	BL,LHW,LMT,LTK,LVL,LW2,QA,QAB1,QAB3,QA2,QA26,QIH1,QME4,QT,QVL RAC,RMB4,SAC,SDS3,SMB4,STM 4575554 QMH	
5	17402-ZE1-810	PAN, CLEANER OIL (OIL BATH) -	1	-	1	-	BL,LHW,LMT,LTK,LVL,LW2,QA,QAB1,QAB3,QA2,QA26,QIH1,QME4,QT,QVL RAC,RMB4,SAC,SDS3,SMB4,STM 4575554 QMH	
6	17403-ZE1-810	ELEMENT, AIR CLEANER (OIL BATH)	1	-	1	-	BL,LHW,LMT,LTK,LVL,LW2,QA,QAB1,QAB3,QA2,QA26,QIH1,QME4,QT,QVL RAC,RMB4,SAC,SDS3,SMB4,STM 4575554 QMH	

Ref. No.	Part No.	Description	Reqd. QTY				Serial No.	Parts catalogue code
			(1)	(2)	(3)	(4)		
7	17404-841-000	GRID, AIR CLEANER	1	-	1	-	BL,LHW,LMT,LTK,LVL,LW2,QA,QAB1,QAB3,QA2,QA26,QIH1,QME4,QT,QVL RAC,RMB4,SAC,SDS3,SMB4,STM	
			1	-	-	-	4575554 QMH	
			-	(1)	-	-		
8	17410-ZE1-020	ELBOW COMP., AIR CLEANER	1	-	1	-	BL,LHW,LMT,LTK,LVL,LW2,QA,QAB1,QAB3,QA2,QA26,QIH1,QME4,QT,QVL RAC,RMB4,SAC,SDS3,SMB4,STM	
			1	-	-	-	4575554 QMH	
			-	(1)	-	-		
9	17421-ZE1-000	CAP, CLEANER	1	-	1	-	BL,LHW,LMT,LTK,LVL,LW2,QA,QAB1,QAB3,QA2,QA26,QIH1,QME4,QT,QVL RAC,RMB4,SAC,SDS3,SMB4,STM	
			1	-	-	-	4575554 QMH	
			-	(1)	-	-		
10	90201-415-000	NUT, CAP, 6MM	2	-	-	-	QA2	
			2	-	-	-	2708121 LMT,LTK,LW2,QT,RAC,SAC	
			2	-	-	-	2709371 QA	
			-	2	-	-	2708121	
11	90203-PB2-000	NUT, AIR CLEANER COVER (DACRO COATING)	1	-	-	-	2468252 LMT,LTK,LW2,QA,QT,RAC,SAC	
			-	(1)	-	-	2468252	
	90203-ZA0-800	NUT, WING, 6MM(BLACK)	1	-	-	-	2836833 QA2	
			1	-	-	-	2468253 2836833 LMT,LTK,LW2,QA,QT,RAC,SAC	
			-	(1)	-	-	2468253 2836833	
12	90325-044-000	NUT, TOOL BOX SETTING	1	-	1	-	BL,LHW,LVL,QAB1,QAB3,QA26,QIH1,QME4,QVL,RMB4,SDS3,SMB4,STM	
			1	-	-	-	2836834 LMT,LTK,LW2,QA,QA2,QT,RAC,SAC	
			1	-	-	-	4575554 QMH	
			-	(1)	-	-	2836834	
13	93404-06020-08	BOLT-WASHER, 6X20	1	-	-	-	3385101 LMT,LTK,QA2	
	93494-06020-08	1	-	-	-	LW2,QA,QT,RAC,SAC	
			-	(1)	-	-		
	95701-06020-00	BOLT, FLANGE, 6X20	1	-	1	-	BL,LHW,LVL,QAB1,QAB3,QA26,QIH1,QME4,QVL,RMB4,SDS3,SMB4,STM	
			1	-	-	-	3385102 LMT,LTK,QA2	
			1	-	-	-	4575554 QMH	
14	94050-06000	NUT, FLANGE, 6MM	2	-	2	-	BL,LHW,LVL,QAB1,QAB3,QA26,QIH1,QME4,QVL,RMB4,SDS3,SMB4,STM	
			2	-	-	-	2708122 LMT,LTK,LW2,QT,RAC,SAC	
			2	-	-	-	2709372 QA	
			2	-	-	-	4575554 QMH	
			-	2	-	-	2708122	

E-15-3

AIR CLEANER(4)

N13

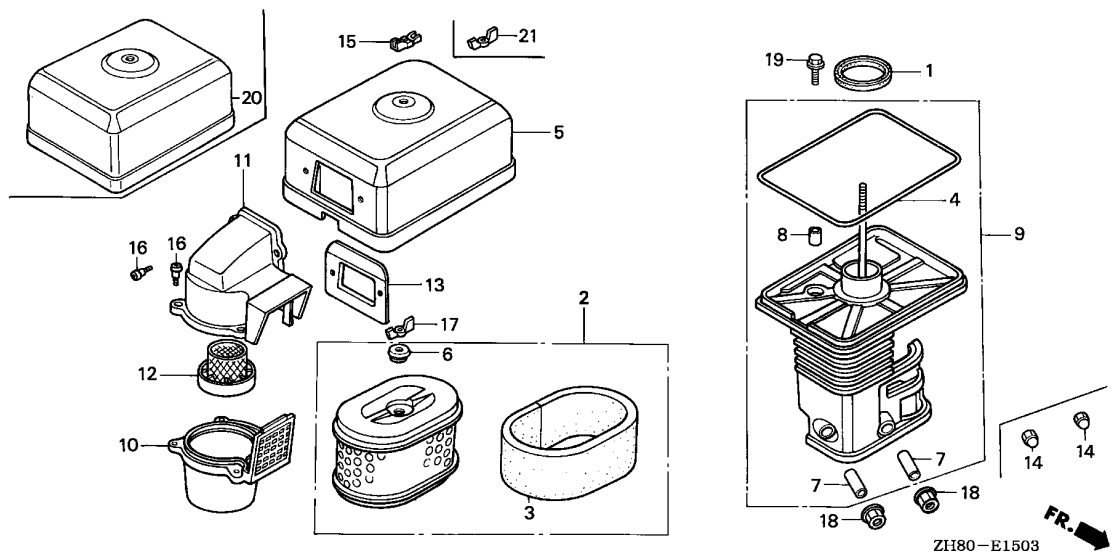

Ref. No.	L.O.N.	(Relative ref. Number) Description	F.R.T.
2	3121B8	ELEMENT, AIR CLEANER	0.1
3	3121C1	FILTER, OUTER	0.1
4	3121E0	PACKING, AIR CLEANER COVER	0.1
9	3121B4	ELBOW, AIR CLEANER	0.1
10	3121A6	CASE, PRE AIR CLEANER	0.1
11	3121A4	CAP, PRE AIR CLEANER	0.1
12	3121C8	GUIDE, PRE AIR CLEANER	0.1

2

Ref. No.	Part No.	Description	Reqd. QTY				Serial No.	Parts catalogue code
			(1)	(2)	(3)	(4)		
1	16271-ZE1-000	PACKING, ELBOW	1	-	-	-	LSS4,QNT4,QSC2,QSC9,QXC,QXC6,QXC9,REX4,TXC9	
2	17210-ZE1-822	ELEMENT, AIR CLEANER (DUAL)	1	(1)	-	-	LSS4,QNT4,QSC2,QSC9,QXC,QXC6,QXC9,REX4,TXC9	
3	17218-ZE1-821	FILTER, OUTER	1	(1)	-	-	LSS4,QNT4,QSC2,QSC9,QXC,QXC6,QXC9,REX4,TXC9	
4	17219-733-010	PACKING, AIR CLEANER COVER	1	(1)	-	-	LSS4,QNT4,QSC2,QSC9,QXC,QXC6,QXC9,REX4,TXC9	
5	17230-ZE1-841	COVER, AIR CLEANER (DUAL)	1	(1)	-	-	LSS4,QNT4,QSC2,QSC9,QXC,QXC6,QXC9,TXC9	
6	17232-891-000	GROMMET, AIR CLEANER	1	(1)	-	-	LSS4,QNT4,QSC2,QSC9,QXC,QXC6,QXC9,REX4,TXC9	
7	17238-ZE7-010	COLLAR, AIR CLEANER	2	(2)	-	-	LSS4,QNT4,QSC2,QSC9,QXC,QXC6,QXC9,REX4,TXC9	
8	17239-733-000	COLLAR B, AIR CLEANER	1	(1)	-	-	LSS4,QNT4,QSC2,QSC9,QXC,QXC6,QXC9,REX4,TXC9	
9	17410-ZE1-840	ELBOW COMP., AIR CLEANER	1	(1)	-	-	LSS4,QNT4,QSC2,QSC9,QXC,QXC6,QXC9,REX4,TXC9	
10	17470-ZE1-841	CASE, PRE AIR CLEANER	-	(1)	-	-	H1,T1,U1,V1	
	17470-ZE1-842		1	(1)	-	-	LSS4,L1,QNT4,QSC2,QSC9,QXC,QXC6,QXC9,Q1,R1,S1,TXC9,W1	
11	17475-ZE1-841	CAP, PRE AIR CLEANER	1	(1)	-	-	LSS4,QNT4,QSC2,QSC9,QXC,QXC6,QXC9,TXC9	
12	17476-ZE1-841	GUIDE, PRE AIR CLEANER	1	(1)	-	-	LSS4,QNT4,QSC2,QSC9,QXC,QXC6,QXC9,TXC9	
13	17478-ZE1-841	PLATE, PRE AIR CLEANER	1	(1)	-	-	LSS4,QNT4,QSC2,QSC9,QXC,QXC6,QXC9,TXC9	

E-15-3

AIR CLEANER(4)

N14

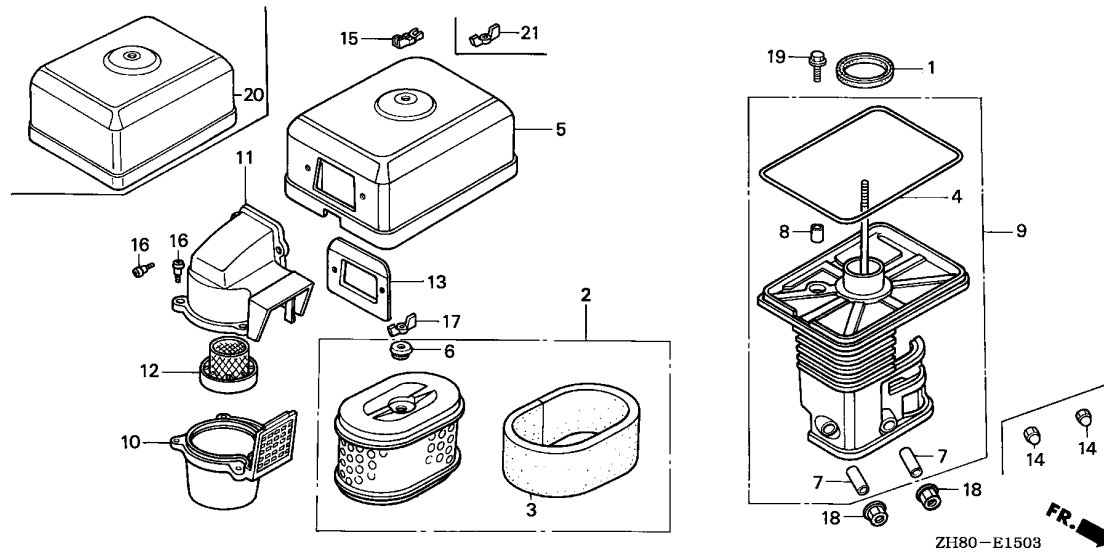

Ref. No.	Part No.	Description	Reqd. QTY				Serial No.	Parts catalogue code
			(1)	(2)	(3)	(4)		
14	90201-415-000	NUT, CAP, 6MM	2	-	-	-	2709371 QXC	
15	90203-PB2-000	NUT, AIR CLEANER COVER (DACRO COATING)	1	-	-	-	2708121	
	90203-ZA0-800	NUT, WING, 6MM(BLACK)	1	(1)	-	-	2468252 QXC	
			1	-	-	-	2468253 QXC	
			1	(1)	-	-	2836833 QXC	
16	90300-GB0-900	BOLT, MUDGUARD	5	-	-	-	LSS4,QNT4,QSC2,QSC9,QXC,QXC6,QXC9,TXC9	
			5	(5)	-	-		
17	90325-044-000	NUT, TOOL BOX SETTING	1	-	-	-	LSS4,QNT4,QSC2,QSC9,QXC,QXC6,QXC9,REX4,TXC9	
			1	(1)	-	-	2836834	
18	94050-06000	NUT, FLANGE, 6MM	2	-	-	-	LSS4,QNT4,QSC2,QSC9,QXC6,QXC9,REX4,TXC9	
			2	-	-	-	2709372 QXC	
			2	-	-	-	2708122	
19	95700-06020-00	BOLT, FLANGE, 6X20	1	-	-	-	QXC	
	95701-06020-00	1	-	-	-	LSS4,QNT4,QSC2,QSC9,QXC6,QXC9,REX4,TXC9	
			1	(1)	-	-		
20	17230-ZE1-820	COVER, AIR CLEANER (DUAL) ...	1	-	-	-	REX4	
21	90325-044-000	NUT, TOOL BOX SETTING	1	-	-	-	LSS4,QNT4,QSC2,QSC9,QXC6,QXC9,REX4,TXC9	
			1	-	-	-	2836834 QXC	
			1	(1)	-	-		

2

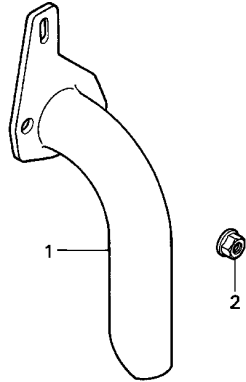

ZH80-E1504



Ref. No.	L.O.N.	(Relative ref. Number) Description	F.R.T.
1	3121E6	PIPE, AIR INTAKE	0.1

Ref. No.	Part No.	Description	Reqd. QTY				Serial No.	Parts catalogue code
			(1)	(2)	(3)	(4)		
1	17201-ZF1-900	PIPE COMP., AIR INTAKE	1	-	-	-	-----	QZ
2	94050-06000	NUT, FLANGE, 6MM	2	-	-	-	-----	QZ

E-15-5

AIR CLEANER(6)

N16

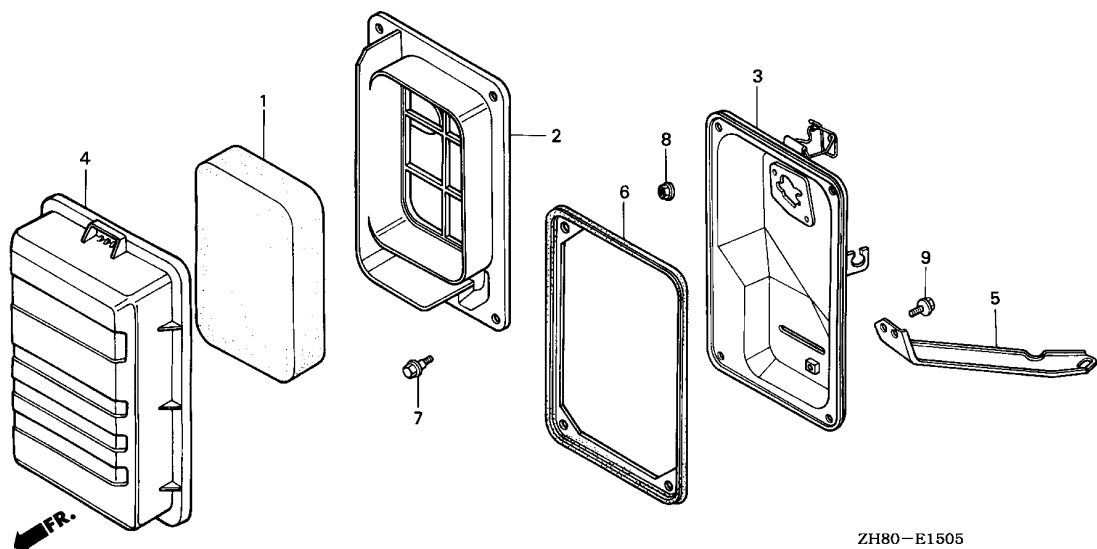

Ref. No.	L.O.N.	(Relative ref. Number) Description	F.R.T.
1	3121B8	ELEMENT, AIR CLEANER	0.1
2	3121F0	SEPARATOR, AIR CLEANER	0.1
3	3121A5	CASE, AIR CLEANER	0.2
6	3121E8	SEAL, AIR CLEANER CASE	0.1

ZH80-E1505

Ref. No.	Part No.	Description	Reqd. QTY				Serial No.	Parts catalogue code
			(1)	(2)	(3)	(4)		
1	17211-ZB2-000	ELEMENT, AIR CLEANER	1	-	-	-	EMA,EMA2,VED2,VED3,VED7,VEN2,VES,VMT,VPM4,VPM5,VPM7,VPR4,VPR7	
2	17212-ZB2-000	SEPARATOR, AIR CLEANER	1	-	-	-	VSB1,VSD1,VSG,VSU,VS17,VS3,VS4,VTE2,VTX,VTX1 EMA,EMA2,VED2,VED3,VED7,VEN2,VES,VMT,VPM4,VPM5,VPM7,VPR4,VPR7	
3	17220-ZB2-000	CASE COMP., AIR CLEANER	1	-	-	-	VSB1,VSD1,VSG,VSU,VS17,VS3,VS4,VTE2,VTX,VTX1 EMA,EMA2,VED2,VED3,VED7,VEN2,VES,VMT,VPM4,VPM5,VPM7,VPR4,VPR7	
4	17231-ZB2-000	COVER, AIR CLEANER	1	-	-	-	VSB1,VSD1,VSG,VSU,VS17,VS3,VS4,VTE2,VTX,VTX1 EMA,EMA2,VED2,VED3,VED7,VEN2,VES,VMT,VPM4,VPM5,VPM7,VPR4,VPR7	
5	17239-ZB2-000	STAY, AIR CLEANER	1	-	-	-	VSB1,VSD1,VSG,VSU,VS17,VS3,VS4,VTE2,VTX,VTX1 EMA,EMA2,VED2,VED3,VED7,VEN2,VES,VMT,VPM4,VPM5,VPM7,VPR4,VPR7	
6	17252-ZB2-000	SEAL, AIR CLEANER	1	-	-	-	EMA,EMA2,VED2,VED3,VED7,VEN2,VES,VMT,VPM4,VPM5,VPM7,VPR4,VPR7 VSB1,VSD1,VSG,VSU,VS17,VS3,VS4,VTE2,VTX,VTX1	
7	90115-459-770	BOLT, WINKER SETTING	4	-	-	-	EMA,EMA2,VED2,VED3,VED7,VEN2,VES,VMT,VPM4,VPM5,VPM7,VPR4,VPR7 VSB1,VSD1,VSG,VSU,VS17,VS3,VS4,VTE2,VTX,VTX1	
8	94050-06080	NUT, FLANGE, 6MM	2	-	-	-	EMA,EMA2,VED2,VED3,VED7,VEN2,VES,VMT,VPM4,VPM5,VPM7,VPR4,VPR7 VSB1,VSD1,VSG,VSU,VS17,VS3,VS4,VTE2,VTX,VTX1	
9	95701-06010-00	BOLT, FLANGE, 6X10	1	-	-	-	EMA,EMA2,VED3,VED7,VEN2,VES,VMT,VPM4,VPM5,VPR4,VSB1,VSD1,VSG VSU,VS3,VS4,VTE2,VTX,VTX1	
	95701-06008-00	BOLT, FLANGE, 6X8	1	-	-	-	3768118 VED2	
			1	-	-	-	VPM7,VPR7,VS17	
			1	-	-	-	3768119 VED2	

2

E-15-6

AIR CLEANER(7)

2-B 1

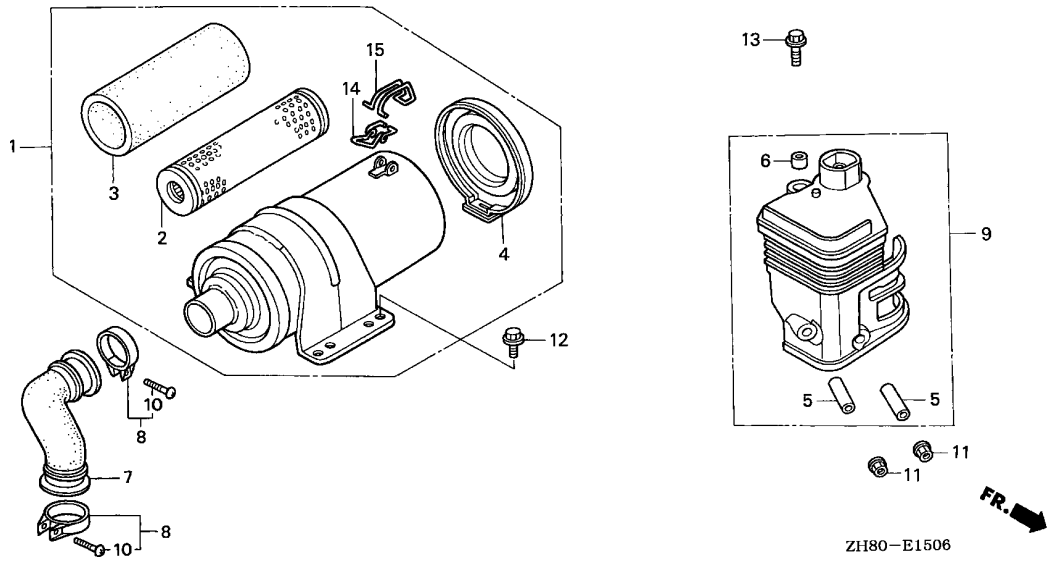

Ref. No.	L.O.N.	(Relative ref. Number) Description	F.R.T.
1	3121B0	CLEANER, AIR	0.1
2	3121B8	ELEMENT, AIR CLEANER	0.1
3	3121C1	FILTER, OUTER	0.1
7	3121F9	TUBE, AIR CLEANER INTAKE	0.1
9	3121B4	ELBOW, AIR CLEANER	0.1

2

Ref. No.	Part No.	Description	Reqd. QTY				Serial No.	Parts catalogue code
			(1)	(2)	(3)	(4)		
			GX160K1					
1	17200-ZK7-V01	CLEANER ASSY., AIR	1	-	-	-	AR,ARC6,KR	
2	17210-ZK7-V01	ELEMENT COMP., AIR CLEANER ..	1	-	-	-	AR,ARC6,KR	
3	17218-ZK7-V01	FILTER, OUTER	1	-	-	-	AR,ARC6,KR	
4	17230-ZK7-V01	COVER COMP., AIR CLEANER	1	-	-	-	AR,ARC6,KR	
5	17238-ZE7-010	COLLAR, AIR CLEANER	2	-	-	-	AR,ARC6,KR	
6	17239-ZE1-000	COLLAR B, AIR CLEANER	1	-	-	-	AR,ARC6,KR	
7	17251-ZE0-S10	TUBE, AIR CLEANER CONNECTING	1	-	-	-	AR,ARC6,KR	
8	17255-758-000	BAND, AIR CLEANER CONNECTING	2	-	-	-	AR,ARC6,KR	
9	17410-ZE1-P30	ELBOW COMP., AIR CLEANER	1	-	-	-	AR,ARC6,KR	
10	93500-04020-0A	SCREW, PAN, 4X20	2	-	-	-	AR,ARC6,KR	
11	94050-06000	NUT, FLANGE, 6MM	2	-	-	-	AR,ARC6,KR	
12	95701-06016-00	BOLT, FLANGE, 6X16	2	-	-	-	AR,ARC6,KR	
13	95701-06020-00	BOLT, FLANGE, 6X20	1	-	-	-	AR,ARC6,KR	
14	17216-PM4-300	CLIP A, WIRE	1	-	-	-	AR,ARC6,KR	
15	17217-PM4-300	CLIP B, WIRE	1	-	-	-	AR,ARC6,KR	

E-15-7

AIR CLEANER(8)

2-B 2

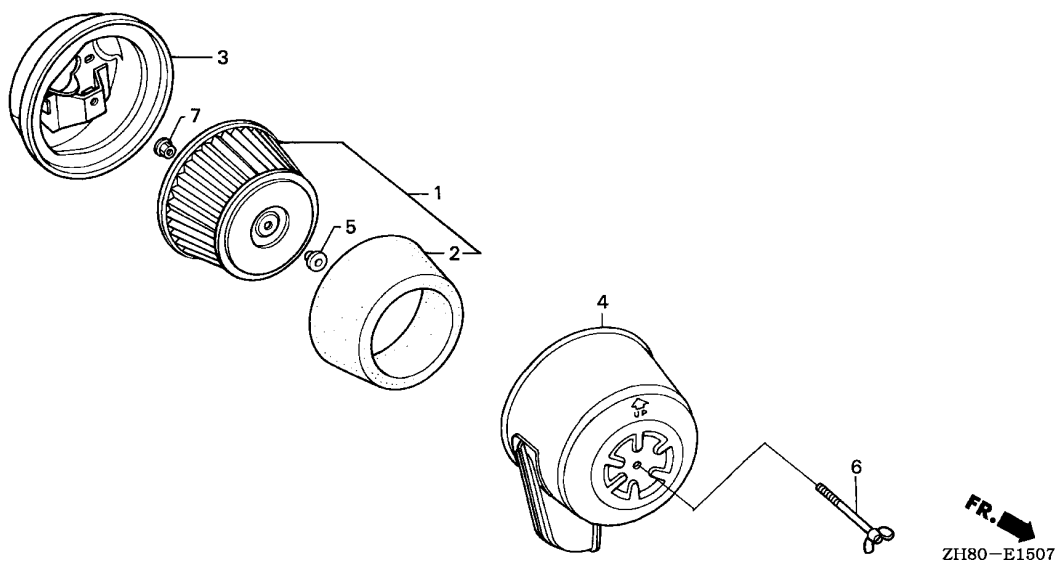

Ref. No.	L.O.N.	(Relative ref. Number) Description	F.R.T.
1	3121B8	ELEMENT, AIR CLEANER	0.1
2	3121H3	ELEMENT B, AIR CLEANER	0.1
3	3121H1	CASE, AIR CLEANER(A)	0.1

Ref. No.	Part No.	Description	Reqd. QTY				Serial No.	Parts catalogue code
			(1)	(2)	(3)	(4)		
				GX160K1				
1	17210-883-903	ELEMENT COMP., AIR CLEANER ..	1	-	-	-	-----	NJC1
2	17218-883-901	ELEMENT B, AIR CLEANER	1	-	-	-	-----	NJC1
3	17220-ZB6-601	CASE COMP., AIR CLEANER	1	-	-	-	-----	NJC1
4	17230-ZB6-000	COVER COMP., AIR CLEANER	1	-	-	-	-----	NJC1
5	17232-890-010	GROMMET, AIR CLEANER	1	-	-	-	-----	NJC1
6	90143-300-020	BOLT, AIR CLEANER COVER	1	-	-	-	-----	NJC1
7	94050-06000	NUT, FLANGE, 6MM	2	-	-	-	-----	NJC1

2

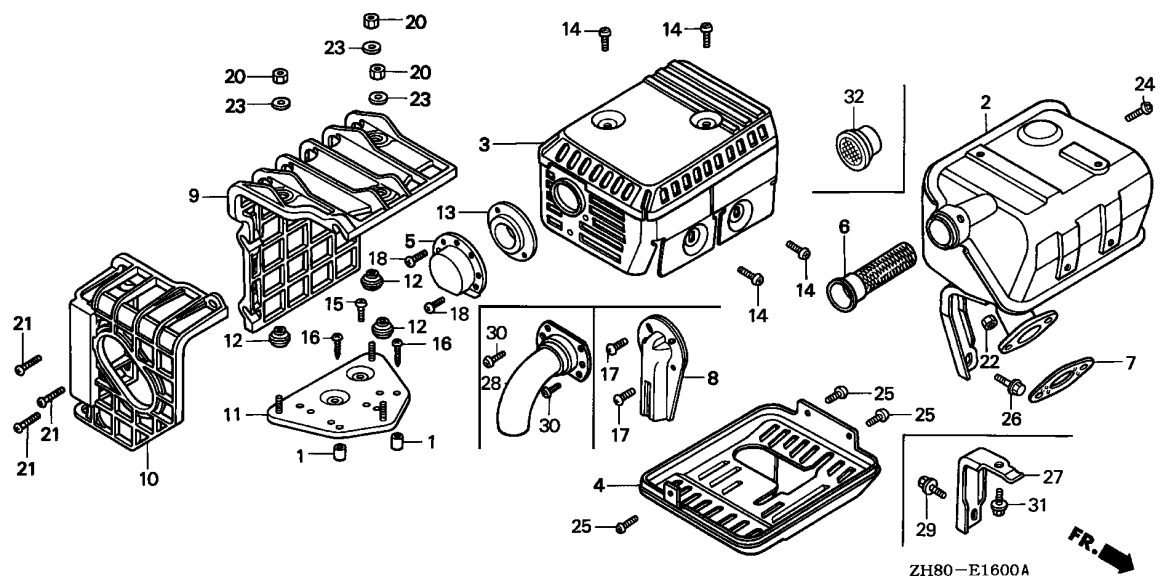

Ref. No.	L.O.N.	(Relative ref. Number) Description	F.R.T.
2	3131C5	MUFFLER, EXHAUST	0.2
3	3131D5	PROTECTOR, EXHAUST MUFFLER :UPPER	0.2
4	3131D2	PROTECTOR, EXHAUST MUFFLER :LOWER	0.2
5	3131A8	DEFLECTOR, EXHAUST MUFFLER ...	0.1
6	3131A1	ARRESTER, SPARK	0.2
7	3131B4	GASKET, EXHAUST MUFFLER	0.2
9	3131A7	COVER, EXHAUST MUFFLER	0.1
10	3131A6	COVER, EXHAUST MUFFLER :REAR ..	0.1
11	3131A2	BASE, EXHAUST MUFFLER COVER ..	0.2

Ref. No.	Part No.	Description	Reqd. QTY				Serial No.	Parts catalogue code
			(1)	(2)	(3)	(4)		
1	17233-896-701	COLLAR, AIR CLEANER CASE	(2)	-	-	(2)	HHQ4, HX4, LD4, LHQ4, LSJ4, LX4, QHQ4, QKA4, QMC6, QME4, QNT4, QXE4, QX4, QX7, RD4, REX4, RHQ4, RMB4, RXE4, RX4, SD4, SG24, SHQ4, SMB4, SMX4, SM14, SWG4, SXE4, SXS4, SX4, SX7, S1CY, TX4, VG24, VHA7, VHH4, VHQ4, VMS7, VSDP, VSD7, VXE4, VXE7, VX4, WDA6, WKT4, WMBO	
2	18310-ZE1-900	MUFFLER COMP.	(2)	-	-	-	3244960	QNT, QXW, RSK, SDS, VSD, VXG, RMD
	18310-ZH7-V90	1	-	-	-		SMX4
	18310-ZH8-810	MUFFLER COMP. (ARRESTER)	1	-	(1)	-		KTA, PHU, QA, QAB1, QA2, QA26, QBC2, QM22, QNT, QNT2, QNT4, SMW2, SM12, STP, STQ, SXS4, S1CY, THU, VA, VA2, VED1, VED5, VED6, VWA, VWA2, VW12, VXW1, WKD6, WKT2, WKT4, WKT6, WME2, WMT
			1	-	-	-	6649704	QAB3
			1	-	-	-	6745958	QMX2
			1	-	-	-	7876111	QWX2
			(1)	-	-	(1)		HG12, HX, HXE, HXE2, HXE8, HXQ, HXU, HX2, HX26, HX4, LAX, LAX2, LX, LXU, LX2, LX26, LX4, PX, PXU, PX2, QAX, QAX2, QBT2, QBT6, QBU2, QCB2, QGR2, QGR9, QKA4, QSC2, QS2, QWM2, QWX3, QX, QXB, QXB1, QXE, QXE2, QXE4, QXE6, QXE8, QXF, QXF2, QXM1, QXQ, QXS, QXS2, QXU, QXW, QXW2, QX2, QX26, QX4, QX7, RFR2, RH, RHA, RHA2, RHQ4, RH2, RH26, RMG2, RSK, RTB2, RXE2, SAD2, SG24, STM, SWX2, SWX4, TCS2, TX, TXU, TX2, TX26, TX4, VGE4, VHA7, VHH4, VMS7, VPM4, VPM7, VPR4, VPR7, VSD, VSDP, VSD7, VXS3, VS17, VTD, VTD1, VTU1, VX, VXG, VXM, VXP, VXU, VXU1, VXW, VXW2, VX2, VX26, VX4
	18310-Z8K-870	MUFFLER COMP. (SILENT)	-	(1)	-	-		QX7, SX7, VHA7, VMS7, VSD7, VXE7

Ref. No.	Part No.	Description	Reqd. QTY				Serial No.	Parts catalogue code
			(1)	(2)	(3)	(4)		
(2)	18310-ZF1-000	MUFFLER COMP. (STD)	1	-	-	1	-----	DS,DSP,EN,ET,ETX,HH,HHQ4,HH26,HX,HXE,HXE2,HXE8,HXQ,HXU,HX2 HX26,HX4,LAX,LAX2,LD,LDB1,LDB3,LDM,LD4,LH,LHB3,LHQ4,LHW,LJ LJC7,LJD,LJG,LSJ,LSJ4,LSS,LSS1,LSS4,LTA,LTK,LW2,LX,LXU,LX2 LX26,LX4,NJ,NJG,NSJ,NW,PH,PHM,PM,PM2,PX,PXU,PX2,QAX,QAX2,QBT2 QBT6,QCB2,QD,QGR2,QGR9,QH,QHE,QHP1,QHQ4,QH26,QM,QMC6,QME4,QMH QP,QPU,QSC2,QSC9,QS2,QT,QWM2,QWX3,QX,QXB,QXB1,QXE,QXE2,QXE4 QXE6,QXE8,QXF,QXF2,QXM1,QXQ,QXS,QXS2,QXU,QXW,QXW2,QX2,QX26,QX4 RAC,RD,RD4,RH,RHA,RHA2,RHQ4,RH2,RH26,RMB4,RMG2,RNG,RSK,RSS1,RX RXE,RXE2,RXE4,RXU,RX4,SAC,SCJ,SD,SDB1,SDB3,SDN,SDS,SDS2,SDS3 SD16,SD4,SEE,SH,SHM,SHQ4,SHRY,SHR4,SJ,SJC,SJC1,SJC5,SJG,SMB4 SMJ1,SM11,SM14,SNX,SNX1,ST,STA,STM,SWX,SWX2,SWX4,SW2,SX,SBX SXE,SXE4,SXU,SX4,TCS2,TH,TX,TXC9,TXU,TX2,TX26,TX4,UH,UX,UXU VED,VH,VHH4,VHQ4,VS,VSD,VSDP,VS1,VTU1,VX,VXD,VXD1,VXE,VXE4 VXE6,VXG,VXM,VXP,VXU,VXU1,VXW,VXW2,VX2,VX26,VX4,WDA6,WJP,WMB0 WME4 6649705 ----- QAB3 7876112 ----- QWX2
	18310-ZE1-821	MUFFLER COMP. (SILENT)	1	-	-	-	-----	HG12,QXC9,RFR2,RTB2,SG24,VEB2,VG24
	18310-ZH8-T30	MUFFLER COMP. (SAKAI-ARRESTER)	1	-	-	-	-----	SSK1,SSK2,SSX2
	18310-ZK8-V50	MUFFLER COMP.	1	-	-	-	6745959 -----	QMX2
3	18320-ZE1-000	PROTECTOR, UPPER	1	-	-	-	-----	2933995 RMD
	18321-ZH8-000	1	-	-	-	-----	2933995 2081153 DS,DSP,HH,HX,LD,LH,LJ,LTA,LW2,LX,PH,PM,PM2,PX,QA,QD,QH,QHE,QM QT,QX,QXE,QXF,QXS,RAC,RD,RH,RX,RXE,SAC,SD,SDS,SEE,SH,SJ,SMJ1 ST,STA,STP,STQ,SWX,SW2,SX,SXE,TH,TX,UH,UX,VA,VED,VED1,VH,VS,VX VXE,VXW
	18320-ZF1-H00	PROTECTOR, MUFFLER (STD.) ...	1	(1)	-	-	2081154 3244959	DS,DSP,HH,HX,LD,LH,LJ,LTA,LW2,LX,L1,PH,PM,PM2,PX,QA,QD,QH,QHE QM,QT,QX,QXE,QXF,QXS,Q1,RAC,RD,RH,RX,RXE,R1,SAC,SD,SDS,SEE,SH SJ,SMJ1,ST,STA,STP,STQ,SWX,SW2,SX,SXE,S1,TH,TX,T1,UH,UX,VA,VED VED1,VH,VS,VX,VXE,VXW,V1,W1
			1	-	-	-	3244959	EN,ET,ETX,HXQ,HX2,KTA,LAX,LJD,LJG,LTK,LX2,PHU,PX2,QAX,QA2,QGR2 QNT,QXB,QXE2,QXF2,QXQ,QXS2,QXW,QX2,RHA,RH2,RSK,SCJ,SJG,SNX SSK1,SBX,THU,TX2,VSD,VS1,VVA,VXG,VXU,VXW1,VXW2,VX2,WMT
			1	-	-	-	2933996 3244959	RMD
			-	(1)	-	-	2081154 -----	H1,U1



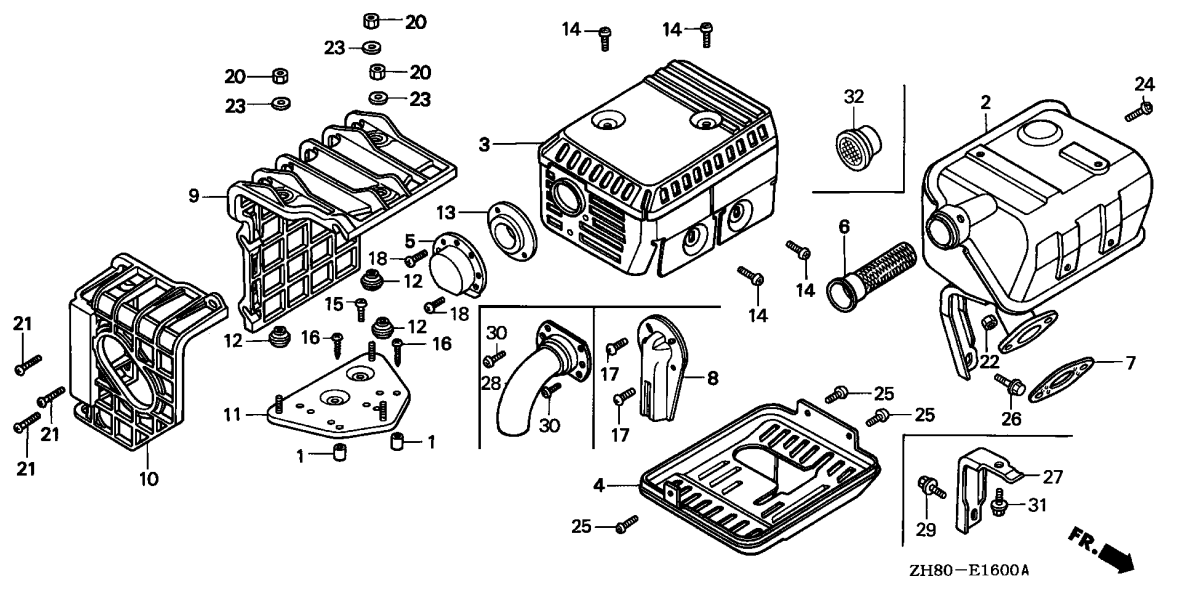

ZH80-E1600A

Ref. No.	Part No.	Description	Reqd. QTY				Serial No.	Parts catalogue code	
			(1)	(2)	(3)	(4)			
			GX160K1						
(3)	18320-ZF1-H01	PROTECTOR, MUFFLER (STD.) (BLACK)	1	-	1	1	-----	HHQ4, HH26, HXE, HXE2, HXE8, HXU, HX26, HX4, LAX2, LDB1, LDB3, LDM, LD4, LHB3, LHQ4, LHW, LJC7, LSJ, LSJ4, LSS, LSS1, LSS4, LXU, LX26, LX4, NJ, NJG, NSJ, NW, PHM, PXU, QAB1, QAB3, QAX2, QA26, QBC2, QBT2, QBT6, QCB2, QGR9, QHP1, QHQ4, QH26, QIH1, QMC6, QME4, QMH, QMX2, QM22, QNT2, QNT4, QP, QPU, QSC2, QSC9, QS2, QWM2, QWX2, QWX3, QXB1, QXE4, QXE6, QXE8, QXM1, QXU, QXW2, QX26, QX4, RD4, RHA2, RHQ4, RH26, RMB4, RMG2, RNG, RSS1, RXE2, RXE4, RXU, RX4, SDB1, SDB3, SDN, SDS2, SDS3, SD16, SD4, SHM, SHQ4, SHRY, SHR4, SJC, SJC1, SJC5, SMB4, SMW2, SMX4, SM11, SM12, SM14, SNX1, SSK2, SSS2, STM, SWX2, SWX4, SXE4, SXS4, SXU, SX4, S1CY, TCS2, TXC9, TXU, TX26, TX4, UXU, VA2, VED5, VED6, VHH4, VHQ4, VIH1, VSDP, VTU1, VWA2, VW12, VXD, VXD1, VXE4, VXE6, VXM, VXP, VXU1, VX26, VX4, WDA6, WIH1, WJP, WKD6, WKT2, WKT4, WKT6, WMB0, WME2, WME4	
			1	-	-	-	3244960	-----	DS, DSP, EN, ET, ETX, HH, HX, HXQ, HX2, KTA, LAX, LD, LH, LJ, LJD, LJG, LTA, LTK, LW2, LX, LX2, PH, PHU, PM, PM2, PX, PX2, QA, QAX, QA2, QD, QGR2, QH, QHE, QM, QNT, QT, QX, QXB, QXE, QXE2, QXF, QXF2, QXQ, QXS, QXS2, QXW, QX2, RAC, RD, RH, RHA, RH2, RMD, RSK, RX, RXE, SAC, SCJ, SD, SDS, SEE, SH, SJ, SJG, SMJ1, SNX, SSK1, ST, STA, STP, STQ, SWX, SW2, SX, SXB, SXE, TH, THU, TX, TX2, UH, UX, VA, VED, VED1, VH, VS, VSD, VS1, VWA, VX, VXE, VXG, VXU, VXW, VXW1, VXW2, VX2, WMT
	18320-ZF1-H51	PROTECTOR, MUFFLER (SILENT) -	1	-	-	-	-----	HG12, QXC9, QX7, RFR2, RTB2, SG24, SX7, VEB2, VG24, VHA7, VMS7, VSD7, VXE7	
	18320-ZE1-T02	PROTECTOR, UPPER (CHROME) ...	-	-	1	-	-----		
4	18325-ZE1-010	PROTECTOR, LOWER	1	-	-	-	-----	DS, DSP, LHW, LJ, LJC7, LJD, LJG, LSJ, LSS, LSS1, LSS4, LTK, NJ, NJG, NSJ, NW, QGR2, QXS, QXS2, RNG, RSS1, SCJ, SHRY, SHR4, SJ, SJC, SJC1, SJC5, SJG, SMJ1, SM11, SNX, SNX1, ST, STA, STM, VXD, VXD1, WJP	
			1	-	-	-	5952747	-----	QGR9
			-	(1)	-	-			



Ref. No.	Part No.	Description	Reqd. QTY				Serial No.	Parts catalogue code
			(1)	(2)	(3)	(4)		
5	18340-ZE1-010	DEFLECTOR COMP.	1	-	-	-	----- QS2,QWX3	
	18331-883-810	CAP, MUFFLER	1	-	1	-	----- KTA,LHW,LJD,LSJ,LSJ4,LSS,LSS1,LSS4,LTK,LW2,NSJ,PHU,QA,QAB1,QA2,QA26,QBT2,QBT6,QIH1,QMC6,QMH,QMX2,QMZ2,QNT,QNT2,QNT4,QP,QPU,QT,QWX2,QWX3,RMB4,RNG,SCJ,SDS,SEE,SHM,SJC,SJC1,SJC5,SMB4,SMW2,SMX4,SM11,SM12,SM14,SNX,SNX1,SSK1,SSK2,SSX2,STA,STP,STQ,SWX,SW2,SXS4,S1CY,THU	
			1	-	-	-	----- 6649704 QAB3	
			-	(1)	-	-		
6	18355-ZE1-000	ARRESTER, SPARK	1	-	-	-	----- KTA,PHU,QA,QAB1,QA2,QA26,QBC2,QMX2,QMZ2,QNT,QNT2,QNT4,SMW2,SM12,SSK1,SSK2,SSX2,STP,STQ,SXS4,S1CY,THU,VA,VA2,VED1,VED5,VED6,VPM5,VWA,VWA2,VW12,VXW1,WKD6,WKT2,WKT4,WKT6,WME2,WMT,LJC7,SJC1,SJC5	
			1	-	-	-	----- 5060214 QAB3	
			1	-	-	-	----- 6649704 QAB3	
			1	-	-	-	----- 7876111 QWX2	
			(1)	-	-	(1)	----- HG12,HX,HXE,HXE2,HXE8,HXQ,HXU,HX2,HX26,HX4,LAX,LAX2,LX,LXU,LX2,LX26,LX4,PX,PXU,PX2,QAX,QAX2,QBT2,QBT6,QBU2,QCB2,QGR2,QGR9,QKA4,QSC2,QS2,QWM2,QWX3,QX,QXB,QXB1,QXE,QXE2,QXE4,QXE6,QXE8,QXF,QXF2,QXM1,QXQ,QXS,QXS2,QXU,QXW,QXW2,QX2,QX26,QX4,QX7,RFR2,RH,RHA,RHA2,RHQ4,RH2,RH26,RMG2,RSK,RTB2,RXE2,SAD2,SG24,STM,SWX2,SWX4,TCS2,TX,TXU,TX2,TX26,TX4,VGE4,VHA7,VHH4,VMS7,VPM4,VPM7,VPR4,VPR7,VSD,VSDP,VSD7,VSX3,VS17,VD,VD1,VTU1,VX,VXG,VXM,VXP,VXU,VXU1,VXW,VXW2,VX2,VX26,VX4	
			-	(1)	-	-		
	18355-ZE1-810	ARRESTER, SPARK (SILENT)	1	-	-	-	----- QXC9,RFR2,SG24,VEB2,VG24	
7	18381-ZH8-800	GASKET, MUFFLER	1	-	-	1	----- DS,DSP,EN,ET,ETX,HG12,HH,HHQ4,HH26,HX,HXE,HXE2,HXE8,HXQ,HXU,HX2,HX26,HX4,KTA,LAX,LAX2,LD,LDB1,LDB3,LDM,LD4,LH,LHB3,LHQ4,LHW,LJ,LJC7,LJD,LJG,LSJ,LSJ4,LSS,LSS1,LSS4,LT,LT,LT2,LX,LXU,LX2,LX26,LX4,NJ,NJC1,NJG,NSJ,NW,PH,PHM,PHU,PM,PM2,PX,PXU,PX2,QA,QAB1,QAB3,QAX,QAX2,QA2,QA26,QBC2,QBT2,QCB2,QD,QGR2,QGR9,QH,QHE,QHP1,QHQ4,QH26,QKA4,QM,QMC6,QME4,QMH,QMX2,QMZ2,QNT,QNT2,QNT4,QP,QPU,QSC2,QSC9,QS2,QT,QWM2,QWX2,QWX3,QX,QXB,QXB1,QXC9,QXE,QXE2,QXE4,QXE6,QXE8,QXF,QXF2,QXM1,QXQ,QXS,QXS2,QXU,QXW,QXW2,QX2,QX26,QX4,QX7,RAC,RD,RD4,REX4,RFR2,RH,RHA,RHA2,RHQ4,RH2,RH26,RMB4,RMD,RMG2,RNG,RSK,RSS1,RTB2,RX,RXE,RXE2,RXE4,RXU,RX4,SAC,SCJ,SD,SDB1,SDB3,SDN,SDS,SDS2,SDS3,SD16,SD4,SEE,SG24,SH,SHM,SHQ4,SHRY,SHR4,SJ,SJC,SJC1,SJC5,SJG,SMB4,SMJ1,SMW2,SMX4,SM11,SM12,SM14,SNX,SNX1,SSK1,SSK2,SSX2,ST,STA,STM,STP,STQ,SWG4,SWX,SWX2,SWX4,SW2,SX,SXB,SXE,SXE4,SXS4,SXU,SX4,SX7,S1CY,SCS2,TH,THU,TX,TXC9,TXU,TX2,TX26,TX4,UH,UX,UXU,VA,VA2,VEB2,VED,VED1,VED5,VED6,VGE4,VG24,VH,VHA7,VHH4,VHQ4,VMS7,VPM4,VPM5,VS,VSD,VSDP,VSD7,VS1,VTU1,VWA,VWA2,VW12,VX,VXD,VXD1,VXE,VXE4,VXE6,VXE7,VXG,VXM,VXP,VXU,VXU1,VXW,VXW1,VXW2,VX2,VX26,VX4,WDA6,WJP,WKD6,WKT2,WKT4,WKT6,WMB0,WME2,WME4,WMT	
			(1)	-	-	-	----- QBT6,QBU2,SAD2	
			-	(1)	1	-		
8	18431-ZH8-W50	DEFLECTOR, MUFFLER	(1)	-	-	-	----- QMC6,QNT4,RMB4,SG24,SMB4,SXS4,VG24	
			(1)	-	-	-	----- QNT,SDS	
9	18433-ZH8-W40	COVER COMP., MUFFLER	(1)	-	-	(1)	----- HHQ4,HX4,LD4,LHQ4,LSJ4,LX4,QHQ4,QKA4,QMC6,QME4,QNT4,QXE4,QX4,QX7,RD4,REX4,RHQ4,RMB4,RXE4,RX4,SD4,SG24,SHQ4,SMB4,SMX4,SM14,SWG4,SXE4,SXS4,SX4,SX7,S1CY,TX4,VG24,VHA7,VHH4,VHQ4,VMS7,VSDP,VSD7,VXE4,VXE7,VX4,WDA6,WKT4,WMB0	
			(1)	-	-	-	----- 3244960 QNT,QXW,RSK,SDS,VSD,VXG	



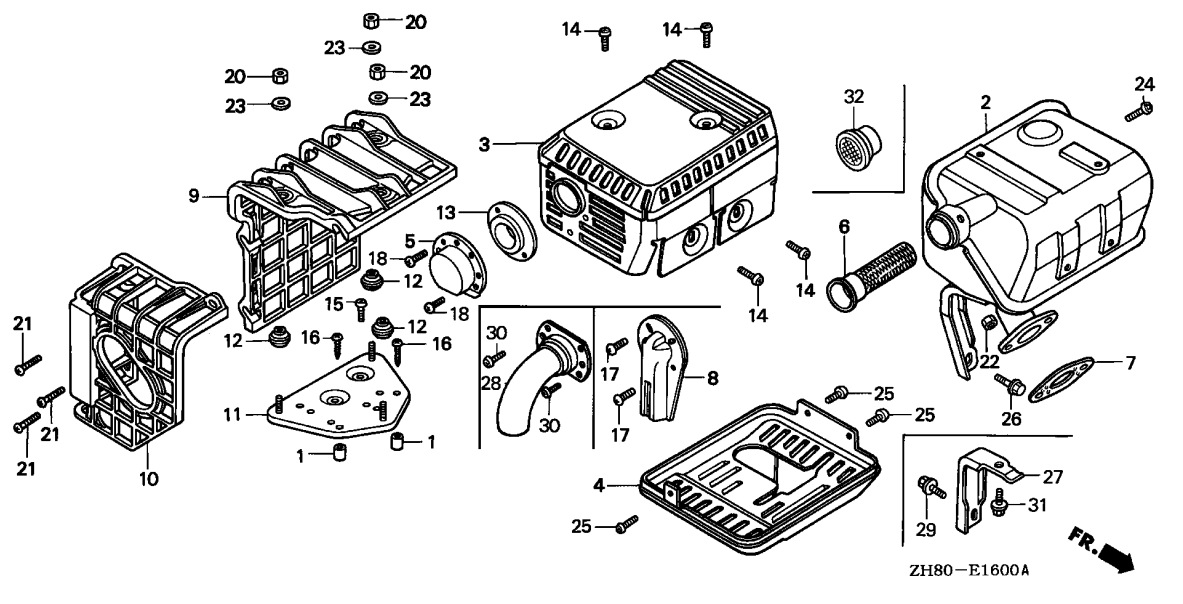

Ref. No.	Part No.	Description	Reqd. QTY				Serial No.	Parts catalogue code	
			(1)	(2)	(3)	(4)			
10	18434-ZH8-W40	COVER COMP., MUFFLER RR.	(1)	-	-	(1)	-----	HHQ4, HX4, LD4, LHQ4, LSJ4, LX4, QHQ4, QKA4, QMC6, QME4, QNT4, QXE4, QX4, QX7, RD4, REX4, RHQ4, RMB4, RXE4, RX4, SD4, SG24, SHQ4, SMB4, SMX4, SM14, SWG4, SXE4, SXS4, SX4, SX7, S1CY, TX4, VG24, VHA7, VHH4, VHQ4, VMS7, VSDP, VSD7, VXE4, VXE7, VX4, WDA6, WKT4, WMBO	
			(1)	-	-	-	3244960	-----	QNT, QXW, RSK, SDS, VSD, VXG
11	18436-ZH8-W40	BASE COMP., MUFFLER COVER ...	(1)	-	-	(1)	-----	HHQ4, HX4, LD4, LHQ4, LSJ4, LX4, QHQ4, QKA4, QMC6, QME4, QNT4, QXE4, QX4, QX7, RD4, REX4, RHQ4, RMB4, RXE4, RX4, SD4, SG24, SHQ4, SMB4, SMX4, SM14, SWG4, SXE4, SXS4, SX4, SX7, S1CY, TX4, VG24, VHA7, VHH4, VHQ4, VMS7, VSDP, VSD7, VXE4, VXE7, VX4, WDA6, WKT4, WMBO	
			(1)	-	-	-	3244960	-----	QNT, QXW, RSK, SDS, VSD, VXG
12	18466-ZH8-W40	SPACER, MUFFLER COVER	(3)	-	-	(3)	-----	HHQ4, HX4, LD4, LHQ4, LSJ4, LX4, QHQ4, QKA4, QMC6, QME4, QNT4, QXE4, QX4, QX7, RD4, REX4, RHQ4, RMB4, RXE4, RX4, SD4, SG24, SHQ4, SMB4, SMX4, SM14, SWG4, SXE4, SXS4, SX4, SX7, S1CY, TX4, VG24, VHA7, VHH4, VHQ4, VMS7, VSDP, VSD7, VXE4, VXE7, VX4, WDA6, WKT4, WMBO	
			(3)	-	-	-	3244960	-----	QNT, QXW, RSK, SDS, VSD, VXG
13	18522-ZE1-000	GUIDE, MUFFLER	1	-	-	1	-----	KTA, LHW, LJD, LSJ, LSJ4, LSS, LSS1, LSS4, LW2, NSJ, PHU, QA, QAB1, QA2, QA26, QBT2, QBT6, QIH1, QMC6, QMH, QMX2, QMZ2, QNT, QNT2, QNT4, QP, QPU, QS2, QT, QWX3, RMB4, RNG, SCJ, SDS, SEE, SHM, SJC1, SJC5, SMB4, SMW2, SMX4, SM11, SM12, SM14, SNX, SNX1, SSK1, SSK2, SSS2, STA, STP, STQ, SWX, SW2, SXS4, S1CY, THU	
			1	-	-	-	3488919	-----	SJC
			1	-	-	-	6649704	-----	QAB3
			1	-	-	-	8558806	-----	QWX2
			-	(1)	-	-			

Ref. No.	Part No.	Description	Reqd. QTY				Serial No.	Parts catalogue code	
			(1)	(2)	(3)	(4)			
14	90050-ZE1-000	SCREW, TAPPING, 5X8	4	-	-	4	-----	DS,DSP,EN,ET,ETX,HH,HHQ4,HH26,HX,HXE,HXE2,HXE8,HXQ,HXU,HX2 HX26,HX4,KTA,LAX,LAX2,LD,LDB1,LDB3,LDM,LD4,LH,LHB3,LHQ4,LHW,LJ LJC7,LJD,LJG,LSJ,LSJ4,LSS,LSS1,LSS4,LTA,LTk,LW2,LX,LXU,LX2 LX26,LX4,NJ,NJG,NSJ,NW,PH,PHM,PHU,PM,PM2,PX,PXU,PX2,QA,QAB1 QAB3,QAX,QAX2,QA2,QA26,QBC2,QBT2,QBT6,QCB2,QD,QGR2,QGR9,QH,QHE QHP1,QHQ4,QH26,QM,QMC6,QME4,QMH,QMX2,QMZ2,QNT,QNT2,QNT4,QP,QPU QSC2,QSC9,QS2,QT,QWM2,QWX2,QWX3,QX,QXB,QXB1,QXC9,QXE,QXE2,QXE4 QXE6,QXE8,QXF,QXF2,QXM1,QXQ,QXS,QXS2,QXU,QXW,QXW2,QX2,QX26,QX4 QX7,RAC,RD,RD4,RFR2,RH,RHA,RHA2,RHQ4,RH2,RH26,RMB4,RMD,RMG2 RNG,RSK,RSS1,RX,RXE,RXE2,RXE4,RXU,RX4,SAC,SCJ,SD,SDB1,SDB3,SDN SDS,SDS2,SDS3,SD16,SD4,SEE,SG24,SH,SHM,SHQ4,SHRY,SHR4,SJ,SJC SJC1,SJC5,SJG,SMB4,SMJ1,SMW2,SMX4,SM11,SM12,SM14,SNX,SNX1,SSK1 SSK2,SSX2,ST,STA,STM,STP,STQ,SWX,SWX2,SWX4,SW2,SX,SXB,SXE,SXE4 SXS4,SXU,SX4,SX7,S1CY,TCS2,TH,THU,TX,TCX9,TXU,TX2,TX26,TX4,UH UX,UXU,VA,VA2,VEB2,VED,VED1,VED5,VED6,VG24,VH,VHA7,VHH4,VHQ4 VMS7,VS,VSD,VSDP,VSD7,VS1,VTU1,VWA,VWA2,VW12,VX,VXD,VXD1,VXE VXE4,VXE6,VXE7,VXG,VXM,VXP,VXU,VXU1,VXW,VXW1,VXW2,VX2,VX26,VX4 WDA6,WJP,WKD6,WKT2,WKT4,WKT6,WMB0,WME2,WME4,WMT	
	90050-ZE3-H00	-----	-	(4)	4	-	-----	HG12,RTB2	
15	90050-ZE1-000	SCREW, TAPPING, 5X8	(1)	-	-	(1)	-----	HHQ4,HX4,LD4,LHQ4,LSJ4,LX4,QHQ4,QKA4,QMC6,QME4,QNT4,QXE4,QX4 QX7,RD4,REX4,RHQ4,RMB4,RXE4,RX4,SD4,SG24,SHQ4,SMB4,SMX4,SM14 SWG4,SXE4,SXS4,SX4,SX7,TX4,VG24,VHA7,VHH4,VHQ4,VMS7,VSDP,VSD7 VXE4,VXE7,VX4,WDA6,WKT4,WMB0	
			(1)	-	-	-	3244960	-----	QNT,QXW,RSK,SDS,VSD,VXG
16	90050-ZH8-W40	SCREW, TAPPING, 5X25	(2)	-	-	(2)	-----	HHQ4,HX4,LD4,LHQ4,LSJ4,LX4,QHQ4,QKA4,QMC6,QME4,QNT4,QXE4,QX4 QX7,RD4,REX4,RHQ4,RMB4,RXE4,RX4,SD4,SG24,SHQ4,SMB4,SMX4,SM14 SWG4,SXE4,SXS4,SX4,SX7,S1CY,TX4,VG24,VHA7,VHH4,VHQ4,VMS7,VSDP VSD7,VXE4,VXE7,VX4,WDA6,WKT4,WMB0	
			(2)	-	-	-	3244960	-----	QNT,QXW,RSK,SDS,VSD,VXG
17	90055-ZE1-000	SCREW, TAPPING, 4X6	(2)	-	-	-	-----	QMC6,QNT4,RMB4,SG24,SMB4,SXS4,VG24	
			(2)	-	-	-	3244960	-----	QNT,SDS
18	90055-ZE1-000	SCREW, TAPPING, 4X6	2	-	-	-	-----	QXC9	
	90002-ZG0-003	SCREW, TAPPING, 4X8	2	-	-	2	-----	LHW,LJD,LSJ,LSJ4,LSS,LSS1,LSS4,PHU,QAB1,QA26,QBT2,QBT6,QIH1 QMC6,QMH,QNT2,QNT4,QP,QPU,QS2,QWX3,RMB4,RNG,SHM,SJC,SJC1,SJC5 SMB4,SMX4,SM11,SM12,SM14,SNX,SNX1,SSK1,SSX2,SXS4,S1CY,THU	
			2	-	-	-	2671948	-----	KTA,LTk,LW2,QA,QNT,QT,SCJ,SDS,SEE,STA,STP,STQ,SWX,SW2
			2	-	-	-	6649704	-----	QAB3
			2	-	-	-	7876111	-----	QWX2
	90183-671-003	-----	2	(2)	-	-	2671948	-----	NSJ
			-	(2)	-	-	2671948	-----	H1,T1,U1,V1,W1
20	90302-KF9-900	NUT, HEX., 5MM	(3)	-	-	(3)	-----	HHQ4,HX4,LD4,LHQ4,LSJ4,LX4,QHQ4,QKA4,QMC6,QME4,QNT4,QXE4,QX4 QX7,RD4,REX4,RHQ4,RMB4,RXE4,RX4,SD4,SG24,SHQ4,SMB4,SMX4,SM14 SWG4,SXE4,SXS4,SX4,SX7,S1CY,TX4,VG24,VHA7,VHH4,VHQ4,VMS7,VSDP VSD7,VXE4,VXE7,VX4,WDA6,WKT4,WMB0	
			(3)	-	-	-	3244960	-----	QNT,QXW,RSK,SDS,VSD,VXG
21	93891-06020-07	SCREW-WASHER, 6X20	(3)	-	-	(3)	-----	HHQ4,HX4,LD4,LHQ4,LSJ4,LX4,QHQ4,QKA4,QMC6,QME4,QNT4,QXE4,QX4 QX7,RD4,REX4,RHQ4,RMB4,RXE4,RX4,SD4,SG24,SHQ4,SMB4,SMX4,SM14 SWG4,SXE4,SXS4,SX4,SX7,S1CY,TX4,VG24,VHA7,VHH4,VHQ4,VMS7,VSDP VSD7,VXE4,VXE7,VX4,WDA6,WKT4,WMB0	
			(3)	-	-	-	3244960	-----	QNT,QXW,RSK,SDS,VSD,VXG



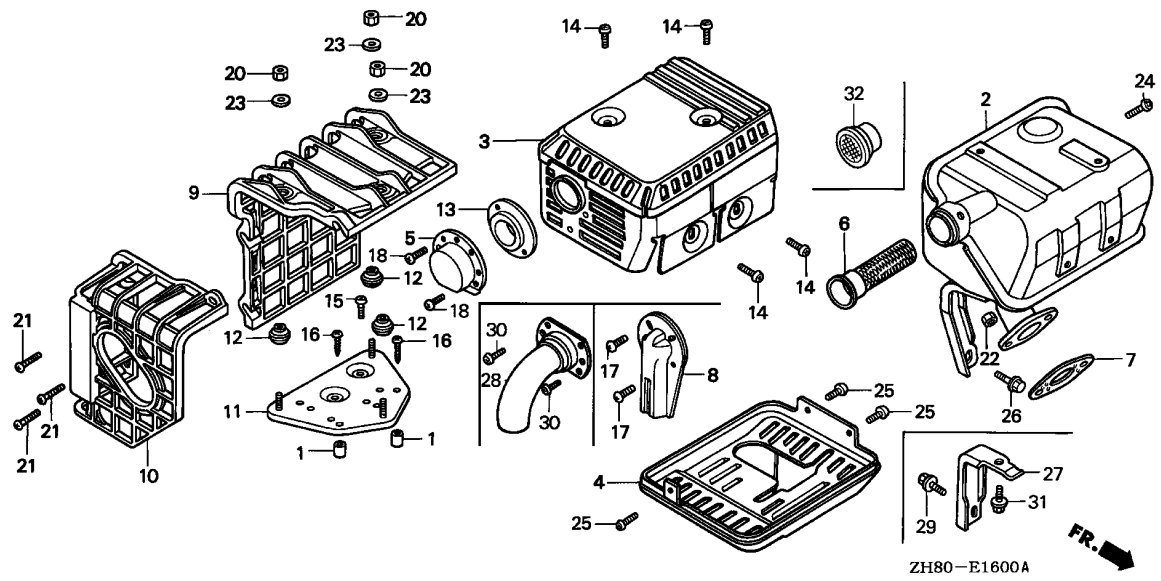

ZH80-E1600A

Ref. No.	Part No.	Description	Reqd. QTY				Serial No.	Parts catalogue code
			(1)	(2)	(3)	(4)		
22	94001-08000-0S	NUT, HEX., 8MM	2	-	-	2	-----	DS,DSP,EN,ET,ETX,HG12,HH,HHQ4,HH26,HX,HXE,HXE2,HXE8,HXQ,HXU HX2,HX26,HX4,KTA,LAX,LAX2,LD,LDB1,LDB3,LDM,LD4,LH,LHB3,LHQ4 LHW,LJ,LJC7,LJD,LJG,LSJ,LSJ4,LSS,LSS1,LSS4,LT,LTK,LW2,LX,LXU LX2,LX26,LX4,NJ,NJG,NSJ,NW,PH,PHM,PHU,PM,PM2,PX,PXU,PX2,QA QAB1,QAB3,QAX,QAX2,QA2,QA26,QBC2,QBT2,QBT6,QCB2,QD,QGR2,QGR9 QH,QHE,QHP1,QHQ4,QH26,QKA4,QM,QMC6,QME4,QMH,QMX2,QMZ2,QNT,QNT2 QNT4,QP,QPU,QSC2,QSC9,QS2,QT,QWM2,QWX2,QWX3,QX,QXB,QXB1,QXC9 QXE,QXE2,QXE4,QXE6,QXE8,QXF,QXF2,QXM1,QXQ,QXS,QXS2,QXU,QXW QXW2,QX2,QX26,QX4,QX7,RAC,RD,RD4,REX4,RFR2,RH,RHA,RHA2,RHQ4 RH2,RH26,RMB4,RMD,RMG2,RNG,RSK,RSS1,RTB2,RX,RXE,RXE2,RXE4,RXU RX4,SAC,SCJ,SD,SDB1,SDB3,SDN,SDS,SDS2,SDS3,SD16,SD4,SEE,SG24 SH,SHM,SHQ4,SHRY,SHR4,SJ,SJC,SJC1,SJC5,SJG,SMB4,SMJ1,SMW2,SMX4 SM11,SM12,SM14,SNX,SNX1,SSK1,SSK2,SSX2,ST,STA,STM,STP,STQ,SWG4 SWX,SWX2,SWX4,SW2,SX,SXB,SXE,SXE4,SXS4,SXU,SX4,SX7,S1CY,TCS2 TH,THU,TX,TC9,TXU,TX2,TX26,TX4,UH,UX,UXU,VA,VA2,VEB2,VED,VED1 VED5,VED6,VG24,VH,VHA7,VHH4,VHQ4,VMS7,VPM4,VPM5,VS,VSD,VSDP VSD7,VS1,VTU1,VWA,VWA2,VW12,VX,VXD,VXD1,VXE,VXE4,VXE6,VXE7,VXG VXM,VXP,VXU,VXU1,VXW,VXW1,VXW2,VX2,VX26,VX4,WDA6,WJP,WKD6,WKT2 WKT4,WKT6,WMB0,WME2,WME4,WMT
23	94103-05700	WASHER, PLAIN, 5MM	(3)	-	-	(3)	-----	HHQ4,HX4,LD4,LHQ4,LSJ4,LX4,QHQ4,QKA4,QMC6,QME4,QNT4,QXE4,QX4 QX7,RD4,REX4,RHQ4,RMB4,RXE4,RX4,SD4,SG24,SHQ4,SMB4,SMX4,SM14 SWG4,SXE4,SXS4,SX4,SX7,S1CY,TX4,VG24,VHA7,VHH4,VHQ4,VMS7,VSDP VSD7,VXE4,VXE7,VX4,WDA6,WKT4,WMB0 ----- (3) - - - 3244960 ----- QNT,QXW,RSK,SDS,VSD,VXG

2

Ref. No.	Part No.	Description	Reqd. QTY				Serial No.	Parts catalogue code
			(1)	(2)	(3)	(4)		
24	90055-ZE1-000	SCREW, TAPPING, 4X6	1	-	-	-	HG12,KTA,PHU,QA,QAB1,QA2,QA26,QBC2,QMX2,QMZ2,QNT,QNT2,QNT4 QWX2,QX7,SMW2,SM12,SSK1,SSK2,SSX2,SXS4,SX7,THU,VA,VA2,VEB2 VED1,VED5,VED6,VMS7,VPM5,VSD7,VVA,VVA2,VW12,VXE7,VXW1,WKD6 WKT2,WKT4,WKT6,WME2	
			1	-	-	-	6649704 QAB3	
			2	(1)	-	(1)	DS,DSP,H1,LJ,LJD,LJG,LSS,LSS1,NJ,NJG,Q1,RNG,R1,SJ,SJC,SJG,SMJ1 SNX,ST,S1,T1,U1,VSDP,VXD,VXD1,VXP,V1,WJP,WMT,W1	
			2	-	-	-	2671947 LTK,LW2,QT,SCJ,SDS,SEE,STA,STP,STQ,SWX,SW2	
			(1)	-	-	-	HX,HXE,HXE2,HXE8,HXQ,HXU,HX2,HX26,HX4,LAX,LAX2,LX,LXU,LX2,LX26 LX4,PX,PXU,PX2,QAX,QAX2,QBT2,QBT6,QBU2,QCB2,QGR2,QGR9,QKA4 QSC2,QWM2,QWX3,QX,QXB,QXB1,QXE,QXE2,QXE4,QXE6,QXE8,QXF,QXF2 QXM1,QXQ,QXS,QXS2,QXU,QXW,QXW2,QX2,QX26,QX4,RH,RHA,RHA2,RHQ4 RH2,RH26,RMG2,RSK,RTB2,RXE2,SAD2,STM,SWX2,SWX4,S1CY,TCS2,TX TXU,TX2,TX26,TX4,VGE4,VHA7,VHH4,VPM4,VPM7,VPR4,VPR7,VSD,VSX3 VS17,VTD,VTD1,VTU1,VX,VXG,VXM,VXU,VXU1,VXW,VXW2,VX2,VX26,VX4 L1,QXC9,RFR2,SG24,VG24,VHA7	
	90056-ZLO-000	1	(1)	-	-		
25	90055-ZE1-000	SCREW, TAPPING, 4X6	3	-	-	-	DS,DSP,LHW,LJ,LJD,LJG,LSJ,LSS,LSS1,LSS4,LTK,NJ,NJG,NSJ,NW,QGR2 QXS,QXS2,RNG,RSS1,SCJ,SHR4,SJ,SJC,SJG,SMJ1,SNX,SNX1,ST,STA,STM STP,STQ,VXD,VXD1,WJP	
			3	-	-	-	5952747 QGR9	
			3	-	-	-	5060213 LJJC7,SJC1,SJC5	
			4	-	-	-	SHRY,SM11	
			-	(3)	-	-		
			-	(4)	-	-		
26	90016-ZE1-000	BOLT, FLANGE, 6X13(CT200) ...	1	-	-	-	SMX4	
27	18315-ZE1-000	STAY, MUFFLER	1	-	-	-	HG12,QXC9,QX7,RFR2,RTB2,SG24,SX7,VEB2,VG24,VHA7,VMS7,VSD7,VXE7	
28	18340-ZE1-000	DEFLECTOR COMP.	1	-	-	-	HG12,QXC9,RFR2,SG24,VEB2,VG24	
29	90016-ZE1-000	BOLT, FLANGE, 6X13(CT200) ...	1	-	-	-	HG12,QXC9,QX7,RFR2,RTB2,SG24,SX7,VEB2,VG24,VHA7,VMS7,VSD7,VXE7	
			1	-	-	-	6745959 QMX2	
30	90002-ZG0-003	SCREW, TAPPING, 4X8	2	-	-	-	QA2,QMX2,QMZ2,QS2,SMW2,SSK2	
31	95701-06012-00	BOLT, FLANGE, 6X12	1	-	-	-	HG12,QXC9,QX7,RFR2,RTB2,SG24,SX7,VEB2,VG24,VHA7,VMS7,VSD7,VXE7	
32	18361-ZLO-000	NETTING, WIRE FLANGE	1	-	-	-	QX7,SX7,VHA7,VMS7,VSD7,VXE7	



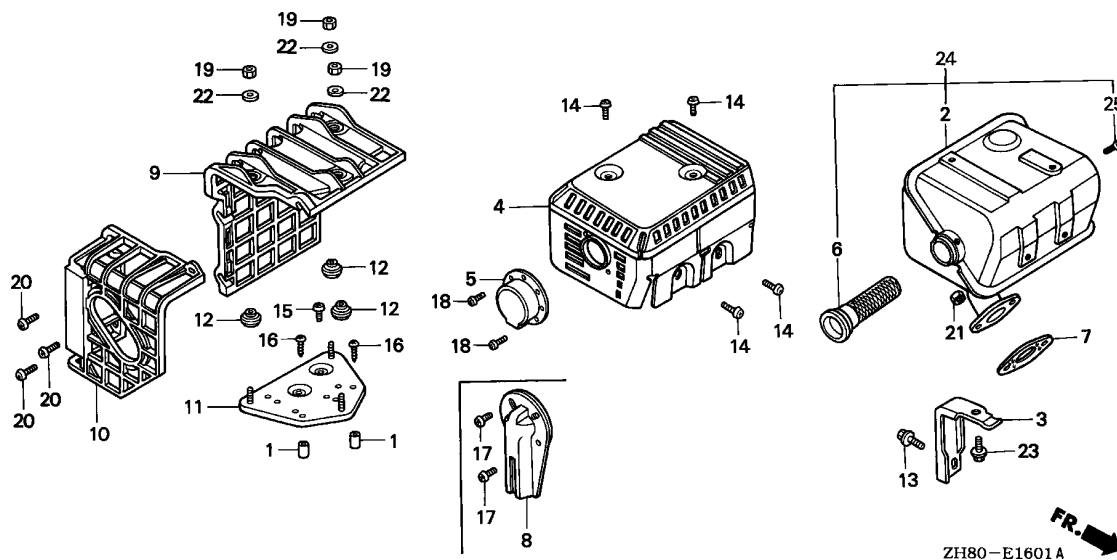

Ref. No.	L.O.N.	(Relative ref. Number) Description	F.R.T.
2	3131C5	MUFFLER, EXHAUST	0.2
4	3131D6	PROTECTOR, EXHAUST MUFFLER ...	0.2
6	3131A1	ARRESTER, SPARK	0.2
7	3131B4	GASKET, EXHAUST MUFFLER	0.2
9	3131A7	COVER, EXHAUST MUFFLER	0.1
10	3131A6	COVER, EXHAUST MUFFLER :REAR -	0.1
11	3131A2	BASE, EXHAUST MUFFLER COVER ..	0.2

Ref. No.	Part No.	Description	Reqd. QTY				Serial No.	Parts catalogue code
			(1)	(2)	(3)	(4)		
1	17233-896-701	COLLAR, AIR CLEANER CASE	(2)	-	-	-	QFE4,QMC8,QMD6,QWA4,SMC7,SMC9,VMB3,VMS4	
2	18310-ZE1-821	MUFFLER COMP. (SILENT)	(2)	-	-	3240676	QE,SE	
			1	-	-	-	HG1,QBU2,QE,QFE4,QMC8,QMD6,QNZ,QWA4,QXC,QXC6,RFR,SAD2,SE,SMC7,SMC9,VEBM,VMB3,VMS4,VSX,VSX1,VSX3,VTD,VTD1	
	18310-ZF1-000	MUFFLER COMP. (STD)	-	(1)	-	-	QCL,QI2,QX22,SXP1	
	18310-ZH8-810	MUFFLER COMP. (ARRESTER)	(1)	-	-	(1)	QCL,QI2,QX22,SXP1	
3	18315-ZE1-000	STAY, MUFFLER	1	-	-	-	HG1,QBU2,QE,QFE4,QMC8,QMD6,QNZ,QWA4,QXC,QXC6,RFR,SAD2,SE,SMC7,SMC9,VEBM,VMB3,VMS4,VSX,VSX1,VSX3,VTD,VTD1	
4	18320-ZF1-H01	PROTECTOR, MUFFLER (STD.) (BLACK)	-	(1)	-	-	QCL,QI2,QX22,SXP1	
	18320-ZF1-H51	PROTECTOR, MUFFLER (SILENT) -	1	-	-	-	HG1,QBU2,QE,QFE4,QMC8,QMD6,QNZ,QWA4,QXC,QXC6,RFR,SAD2,SE,SMC7,SMC9,VEBM,VMB3,VMS4,VSX,VSX1,VSX3,VTD,VTD1	
5	18331-883-810	CAP, MUFFLER	1	-	-	-	HG1,QBU2,QMC8,QWA4,QXC,QXC6,RFR,SAD2,SMC7,VEBM	
			-	(1)	-	-		
6	18355-ZE1-000	ARRESTER, SPARK	1	-	-	-	RFR	
			(1)	-	-	(1)	HG1,QCL,QI2,QX22,SXP1	
	18355-ZE1-810	ARRESTER, SPARK (SILENT)	1	-	-	-	QBU2,QE,QFE4,QMC8,QMD6,QNZ,QWA4,QXC,QXC6,SAD2,SE,SMC7,SMC9,VEBM,VMB3,VMS4	
			1	-	-	-	4224868 VSX,VSX1	
			-	(1)	-	-		
7	18381-ZH8-800	GASKET, MUFFLER	1	-	-	1	HG1,QBU2,QCL,QE,QFE4,QI2,QMC8,QMD6,QNZ,QWA4,QXC,QXC6,QX22,RFR,SAD2,SE,SMC7,SMC9,SXP1,VEBM,VMB3,VMS4,VSX,VSX1,VSX3,VTD,VTD1	
			-	(1)	-	-		
8	18431-ZH8-W50	DEFLECTOR, MUFFLER	(1)	-	-	-	QMC8,QWA4,SMC7	

Ref. No.	Part No.	Description	Reqd. QTY				Serial No.	Parts catalogue code
			GX160K1					
			(1)	(2)	(3)	(4)		
9	18433-ZH8-W40	COVER COMP., MUFFLER	(1)	-	-	-	QFE4,QMC8,QMD6,QWA4,SMC7,SMC9,VMB3,VMS4	
			(1)	-	-	3240676	QE,SE	
10	18434-ZH8-W40	COVER COMP., MUFFLER RR.	(1)	-	-	-	QFE4,QMC8,QMD6,QWA4,SMC7,SMC9,VMB3,VMS4	
			(1)	-	-	3240676	QE,SE	
11	18436-ZH8-W40	BASE COMP., MUFFLER COVER ...	(1)	-	-	-	QFE4,QMC8,QMD6,QWA4,SMC7,SMC9,VMB3,VMS4	
			(1)	-	-	3240676	QE,SE	
12	18466-ZH8-W40	SPACER, MUFFLER COVER	(3)	-	-	-	QFE4,QMC8,QMD6,QWA4,SMC7,SMC9,VMB3,VMS4	
			(3)	-	-	3240676	QE,SE	
13	90016-ZE1-000	BOLT, FLANGE, 6X13(CT200) ...	1	-	-	-	HG1,QBU2,QE,QFE4,QMC8,QMD6,QNZ,QWA4,QXC,QXC6,RFR,SAD2,SE,SMC7,SMC9,VEBM,VMB3,VMS4,VSX,VSX1,VSX3,VTD,VTD1	
	95900-06012-00	BOLT, FLANGE, 6X12	-	(1)	-	-	H1,T1,U1,W1	
			-	(1)	-	3240675	L1,Q1,R1,S1,V1	
	95701-06012-00	-	(1)	-	3240676	L1,Q1,R1,S1,V1	
14	90050-ZE1-000	SCREW, TAPPING, 5X8	4	-	-	4	QBU2,QCL,QE,QFE4,QI2,QMC8,QMD6,QNZ,QWA4,QXC,QXC6,QX22,RFR,SAD2,SE,SMC7,SMC9,SXP1,VEBM,VMB3,VMS4	
			4	-	-	4224868	VSX,VSX1	
			-	(4)	-	-		
	90050-ZE3-H00	4	-	-	-	HG1,VSX3,VTD,VTD1	
			4	-	-	4224869	VSX,VSX1	
15	90050-ZE1-000	SCREW, TAPPING, 5X8	(1)	-	-	-	QFE4,QMC8,QMD6,QWA4,SMC7,SMC9,VMB3,VMS4	
			(1)	-	-	3240676	QE,SE	
16	90050-ZH8-W40	SCREW, TAPPING, 5X25	(2)	-	-	-	QFE4,QMC8,QMD6,QWA4,SMC7,SMC9,VMB3,VMS4	
			(2)	-	-	3240676	QE,SE	
17	90055-ZE1-000	SCREW, TAPPING, 4X6	(2)	-	-	-	QMC8,QWA4,SMC7	
18	90055-ZE1-000	SCREW, TAPPING, 4X6	2	-	-	-	HG1,QBU2,QMC8,QWA4,QXC,QXC6,RFR,SAD2,SMC7,VEBM	
			-	(2)	-	-		
19	90302-KF9-900	NUT, HEX., 5MM	(3)	-	-	-	QFE4,QMC8,QMD6,QWA4,SMC7,SMC9,VMB3,VMS4	
			(3)	-	-	3240676	QE,SE	
20	93891-06020-07	SCREW-WASHER, 6X20	(3)	-	-	-	QFE4,QMC8,QMD6,QWA4,SMC7,SMC9,VMB3,VMS4	
			(3)	-	-	3240676	QE,SE	
21	94001-08000-0S	NUT, HEX., 8MM	2	-	-	2	HG1,QBU2,QCL,QE,QFE4,QI2,QMC8,QMD6,QNZ,QWA4,QXC,QXC6,QX22,RFR,SAD2,SE,SMC7,SMC9,SXP1,VEBM,VMB3,VMS4,VSX,VSX1,VSX3,VTD,VTD1	
			-	2	-	-		
22	94103-05700	WASHER, PLAIN, 5MM	(3)	-	-	-	QFE4,QMC8,QMD6,QWA4,SMC7,SMC9,VMB3,VMS4	
			(3)	-	-	3240676	QE,SE	
23	95900-06012-00	BOLT, FLANGE, 6X12	1	(1)	-	-	HG1,H1,QXC,T1,U1,W1	
			1	(1)	-	3240675	L1,QE,QNZ,Q1,RFR,R1,SE,S1,VEBM,VSX,VSX1,V1	
	95701-06012-00	1	(1)	-	3240676	L1,QE,QNZ,Q1,RFR,R1,SE,S1,VEBM,VSX,VSX1,V1	
			1	-	-	-	QBU2,QFE4,QMC8,QMD6,QWA4,QXC6,SAD2,SMC7,SMC9,VMB3,VMS4,VSX3,VTD,VTD1	
24	183A1-ZE1-821	MUFFLER COMP. (SILENT)	1	-	-	-	QXC	
			-	(1)	-	-		
25	90055-ZE1-000	SCREW, TAPPING, 4X6	1	-	-	-	QBU2,RFR,SAD2	
			1	-	-	4224868	VSX,VSX1	
			(1)	(1)	-	(1)	HG1,H1,QCL,QI2,QX22,Q1,R1,SXP1,S1,T1,U1,V1,W1	
	90056-ZL0-000	1	(1)	-	-	L1,QE,QFE4,QMC8,QMD6,QNZ,QWA4,QXC,QXC6,SE,SMC7,SMC9,VEBM,VMB3,VMS4	



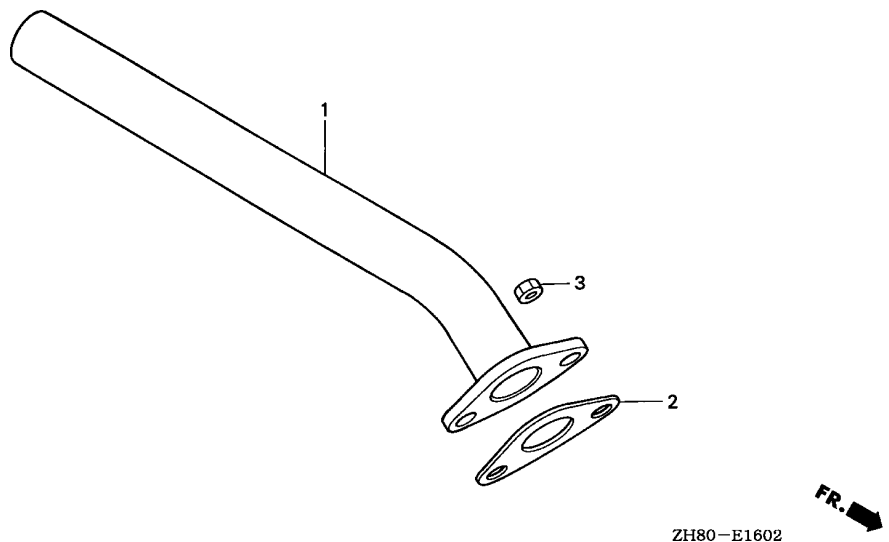

Ref. No.	L.O.N.	(Relative ref. Number) Description	F.R.T.
1	3131C5	MUFFLER, EXHAUST	0.1
2	3131B4	GASKET, EXHAUST MUFFLER	0.1

2

Ref. No.	Part No.	Description	Reqd. QTY				Serial No.	Parts catalogue code
			(1)	(2)	(3)	(4)		
				GX160K1				
1	18321-ZF1-910	MUFFLER COMP.	1	-	-	-	-----	QZ
2	18381-ZH8-800	GASKET, MUFFLER	1	-	-	-	-----	QZ
3	94001-08000-0S	NUT, HEX., 8MM	2	-	-	-	-----	QZ

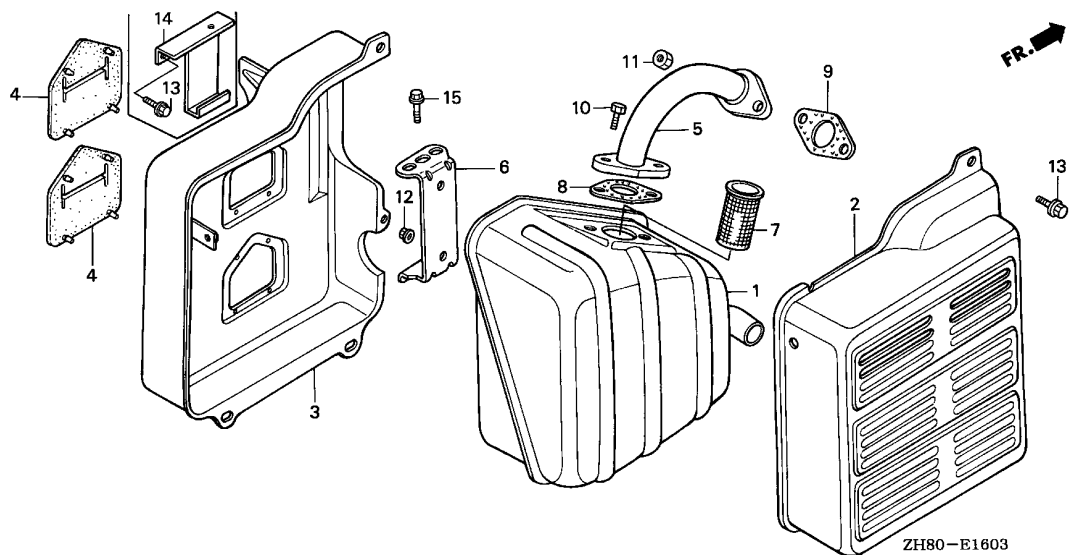

Ref. No.	L.O.N.	(Relative ref. Number) Description	F.R.T.
1	3131C5	MUFFLER, EXHAUST	0.2
2	3131D9	PROTECTOR, EXHAUST MUFFLER : OUTER	0.1
3	3131D8	PROTECTOR, EXHAUST MUFFLER : INNER	0.2
4	3131G6	SEAL, MUFFLER PROTECTOR	0.2
5	3131C9	PIPE, EXHAUST	0.2
7	3131A1	ARRESTER, SPARK	0.2
8	3131B4	GASKET, EXHAUST MUFFLER	0.2

Ref. No.	Part No.	Description	Reqd. QTY				Serial No.	Parts catalogue code
			(1)	GX160K1 (2)	(3)	(4)		
1	18310-ZB3-C00	MUFFLER COMP.	1	-	-	-	EMA,EMA2,VED2,VED3,VED7,VEN2,VES,VMT,VPR4,VPR7,VSB1,VSD1,VSG VSW,VS17,VS3,VS4,VTE2,VTX,VTX1	
	18310-ZB2-000	1	-	-	-	SKM	
2	18320-ZB2-000	PROTECTOR, MUFFLER OUTER	1	-	-	-	EMA,EMA2,SKM,VED2,VED3,VED7,VES,VMT,VSB1,VSG,VSW,VS3,VS4,VTE2 VTX,VTX1	
3	18325-ZB2-000	PROTECTOR, MUFFLER INNER	1	-	-	-	VED2,VED3,VED7,VEN2,VES,VMT,VSB1,VSG,VSW,VS3,VS4,VTE2,VTX,VTX1	
	18325-ZH8-V10	PROTECTOR, MUFFLER INNER (KOMATSU)	1	-	-	-	3293354 SKM	
	18325-ZH8-T90	PROTECTOR, MUFFLER INNER (DENYO)	1	-	-	-	EMA,EMA2	
			1	-	-	-	3293355 SKM	
4	18329-ZB2-000	SEAL, MUFFLER PROTECTOR	2	-	-	-	EMA,EMA2,SKM,VED2,VED3,VED7,VEN2,VES,VMT,VSB1,VSG,VSW,VS3,VS4 VTE2,VTX,VTX1	
5	18330-ZB2-000	PIPE COMP., EX.	1	-	-	-	SKM,VED2,VED3,VED7,VEN2,VES,VMT,VSB1,VSD1,VSG,VSW,VS17,VS3,VS4 VTE2,VTX,VTX1	
	18330-ZH8-T90	PIPE COMP., EX. (DENYO)	1	-	-	-	EMA,EMA2	
6	18338-ZB3-E30	STAY, MUFFLER	1	-	-	-	VED2,VED3,VED7,VEN2,VES,VMT,VSB1,VSG,VSW,VS3,VS4,VTE2,VTX,VTX1	
7	18355-898-630	ARRESTER, SPARK	1	-	-	-	EMA,EMA2,VED2,VED3,VED7,VEN2,VES,VMT,VPR4,VPR7,VSD1,VS17,VTE2	
			1	-	-	-	4224868 VS3,VS4	
8	18381-ZE1-800	GASKET, MUFFLER	1	-	-	-	EMA,EMA2,VED2,VED3,VED7,VEN2,VES,VMT,VPR4,VPR7,VSB1,VSD1,VSG VSW,VS17,VS3,VS4,VTE2,VTX,VTX1	
9	18381-ZH8-800	GASKET, MUFFLER	1	-	-	-	EMA,EMA2,SKM,VED2,VED3,VED7,VEN2,VES,VMT,VPM7,VPR4,VPR7,VSB1 VSD1,VSG,VSW,VS17,VS3,VS4,VTE2,VTX,VTX1	
10	92101-08020-0A	BOLT, HEX., 8X20	2	-	-	-	EMA,SKM,VED2,VED3,VED7,VEN2,VES,VMT,VPR4,VPR7,VSB1,VSD1,VSG VSW,VS17,VS3,VS4,VTE2,VTX,VTX1	



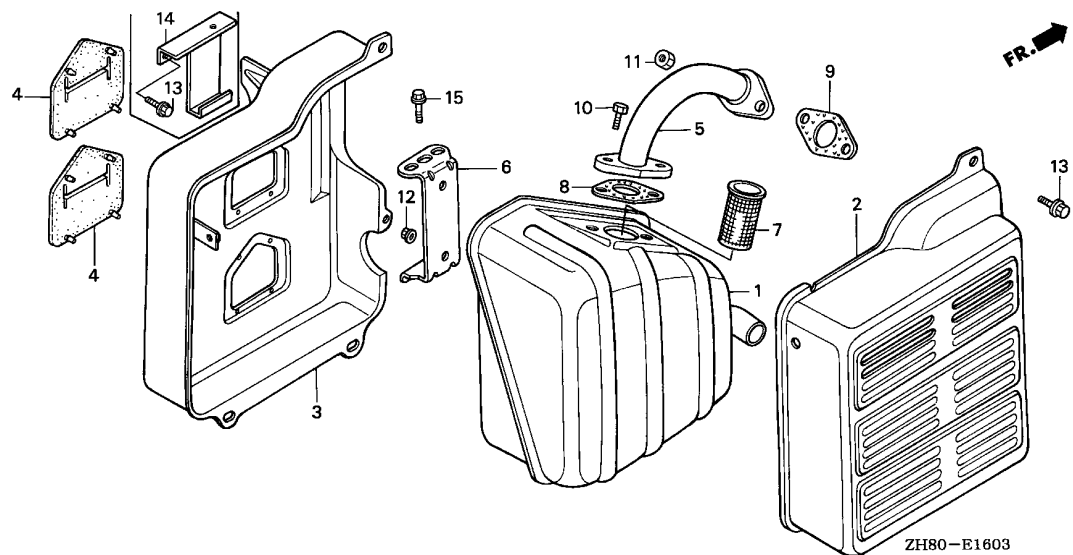

ZH80-E1603

Ref. No.	Part No.	Description	Reqd. QTY				Serial No.	Parts catalogue code
			(1)	(2)	(3)	(4)		
				GX160K1				
11	94001-08000-0S	NUT, HEX., 8MM	2	-	-	-	EMA,SKM,VED2,VED3,VED7,VEN2,VES,VMT,VPM7,VPR4,VPR7,VS1,VED1	
12	94050-06000	NUT, FLANGE, 6MM	2	-	-	-	VSG,VSW,VS17,VS3,VS4,VTE2,VTX,VTX1	
13	95701-06012-00	BOLT, FLANGE, 6X12	5	-	-	-	VED2,VED3,VED7,VEN2,VES,VMT,VS1,VSG,VSW,VS3,VS4,VTE2,VTX,VTX1	
14	18521-ZD8-K61	BRACKET, MUFFLER	7	-	-	-	EMA,SKM,VED2,VED3,VED7,VES,VMT,VS1,VSW,VS3,VS4,VTE2	
15	95801-08020-18	BOLT, FLANGE, 8X20	1	-	-	-	VTX,VTX1	
			1	-	-	-	VTX,VTX1	
			1	-	-	-	VED2,VEN2,VES	

E-16-4

MUFFLER(5)

2-B16

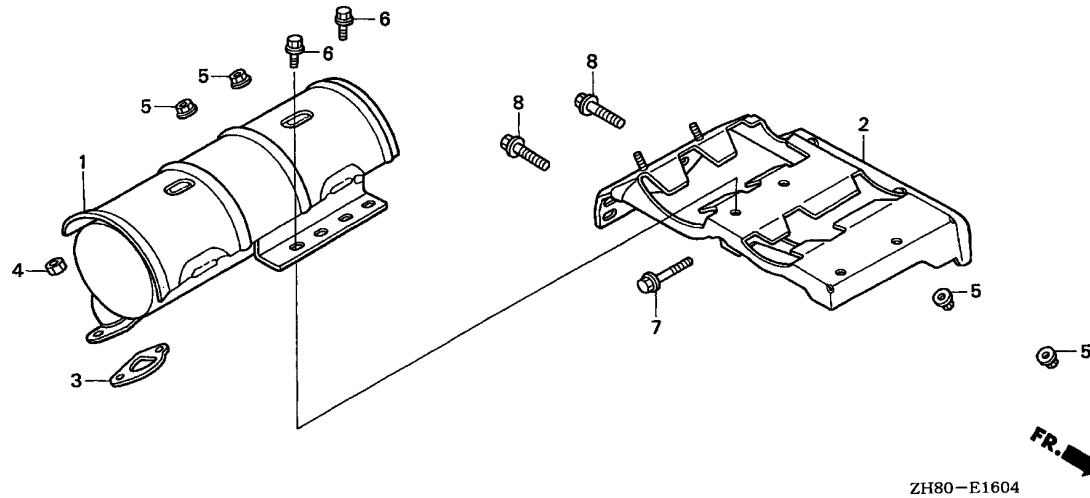

Ref. No.	L.O.N.	(Relative ref. Number) Description	F.R.T.
1	3131C5	MUFFLER, EXHAUST	0.2
2	3131E1	STAY, MUFFLER	0.3
3	3131B4	GASKET, EXHAUST MUFFLER	0.2

Ref. No.	Part No.	Description	Reqd. QTY				Serial No.	Parts catalogue code
			(1)	(2)	(3)	(4)		
			GX160K1					
1	18310-ZK7-V01	MUFFLER COMP.	1	-	-	-	AR,ARC6,KR	
2	18338-ZK8-V01	STAY COMP., MUFFLER	1	-	-	-	AR,ARC6,KR	
3	18381-ZH8-800	GASKET, MUFFLER	1	-	-	-	AR,ARC6,KR	
4	94001-08000-0S	NUT, HEX., 8MM	2	-	-	-	AR,ARC6,KR	
5	94050-06000	NUT, FLANGE, 6MM	4	-	-	-	AR,ARC6,KR	
6	95701-06016-00	BOLT, FLANGE, 6X16	2	-	-	-	AR,ARC6,KR	
7	95701-06025-00	BOLT, FLANGE, 6X25	1	-	-	-	AR,ARC6,KR	
8	95701-08020-00	BOLT, FLANGE, 8X20	2	-	-	-	AR,ARC6,KR	

2

FR. →

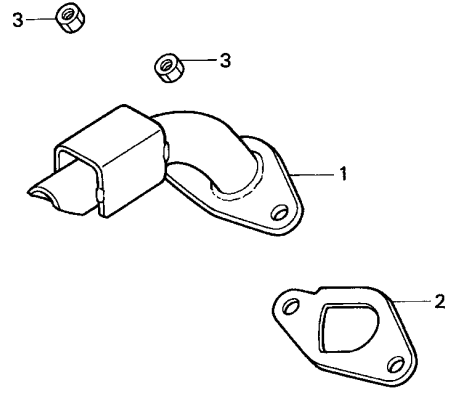

ZH80-E1605

Ref. No.	L.O.N.	(Relative ref. Number) Description	F.R.T.
1	3131G1	PIPE, EXHAUST(A)	0.1
2	3131H1	GASKET, EXHAUST MUFFLER(A) ...	0.1

2

Ref. No.	Part No.	Description	Reqd. QTY				Serial No.	Parts catalogue code
			(1)	(2)	(3)	(4)		
				GX160K1				
1	18310-ZL0-W80	PIPE, EX.	1	-	-	-	-----	BL,LVL,QVL
2	18381-ZH8-800	GASKET, MUFFLER	1	-	-	-	-----	BL,LVL,QVL
3	94001-08000-0S	NUT, HEX., 8MM	2	-	-	-	-----	BL,LVL,QVL

E-16-6

MUFFLER(7)

2-C 2

FR.

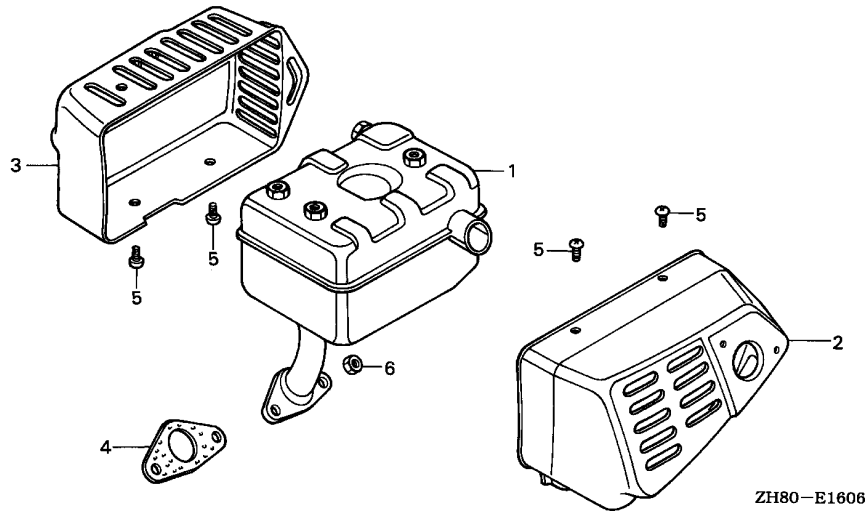

Ref. No.	L.O.N.	(Relative ref. Number) Description	F.R.T.
1	3131C5	MUFFLER, EXHAUST	0.2
2	3131D3	PROTECTOR, EXHAUST MUFFLER :REAR	0.1
3	3131H0	PROTECTOR, EXHAUST MUFFLER :FRONT	0.1
4	3131B4	GASKET, EXHAUST MUFFLER	0.2

Ref. No.	Part No.	Description	Reqd. QTY				Serial No.	Parts catalogue code
			(1)	GX160K1 (2)	(3)	(4)		
1	18310-734-750	MUFFLER COMP.	1	-	-	-	-----	LJS
2	18312-734-000	PROTECTOR, L. MUFFLER	1	-	-	-	-----	LJS
3	18313-734-000	PROTECTOR, R. MUFFLER	1	-	-	-	-----	LJS
4	18381-ZH8-800	GASKET, MUFFLER	1	-	-	-	-----	LJS
5	93500-06006-0B	SCREW, PAN, 6X6	6	-	-	-	-----	LJS
6	94001-08000-0S	NUT, HEX., 8MM	2	-	-	-	-----	LJS

2

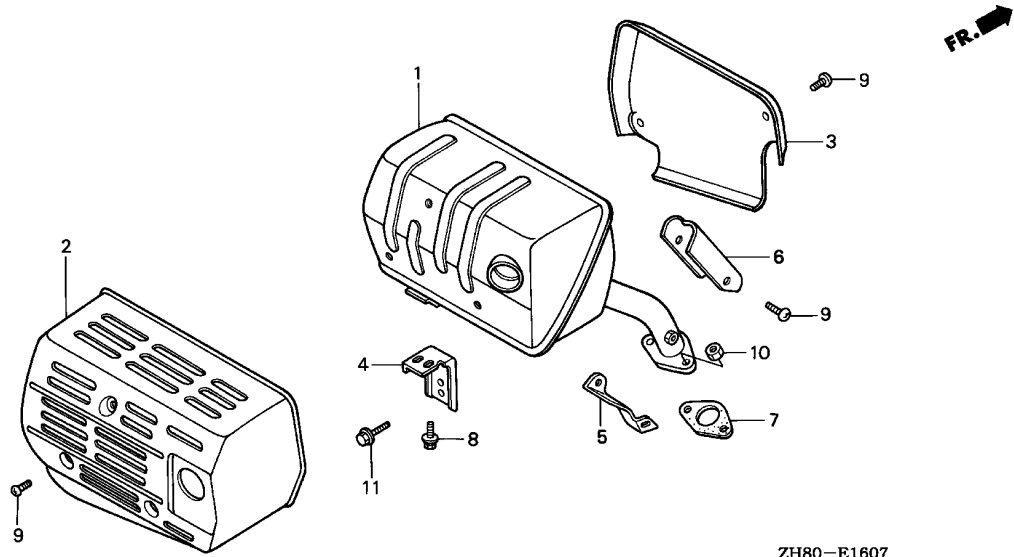

ZH80-E1607

Ref. No.	L.O.N.	(Relative ref. Number) Description	F.R.T.
1	3131C5	(3) MUFFLER, EXHAUST	0.2
2	3131D6	PROTECTOR, EXHAUST MUFFLER ...	0.2
7	3131B4	GASKET, EXHAUST MUFFLER	0.2

2

Ref. No.	Part No.	Description	Reqd. QTY				Serial No.	Parts catalogue code
			(1)	(2)	(3)	(4)		
			GX160K1					
1	18310-ZE1-S40	MUFFLER COMP.	1	-	-	-	-----	LMT
2	18311-ZE1-S40	PROTECTOR, MUFFLER	1	-	-	-	-----	LMT
3	18315-ZE1-S40	SEPARATOR, MUFFLER	1	-	-	-	-----	LMT
4	18316-ZE1-S40	STAY, MUFFLER	1	-	-	-	-----	LMT
5	18317-ZE1-S40	PROTECTOR, EX. PIPE (LOWER) -	1	-	-	-	-----	LMT
6	18323-ZE1-S40	PROTECTOR, EX. PIPE	1	-	-	-	-----	LMT
7	18381-ZH8-800	GASKET, MUFFLER	1	-	-	-	-----	LMT
8	93406-08016-00	BOLT-WASHER, 8X16	1	-	-	-	-----	LMT
9	93500-06006-0A	SCREW, PAN, 6X6	7	-	-	-	-----	LMT
10	94001-08000-0S	NUT, HEX., 8MM	2	-	-	-	-----	LMT
11	95701-08020-00	BOLT, FLANGE, 8X20	1	-	-	-	-----	LMT

E-16-8

MUFFLER(9)

2-C 4

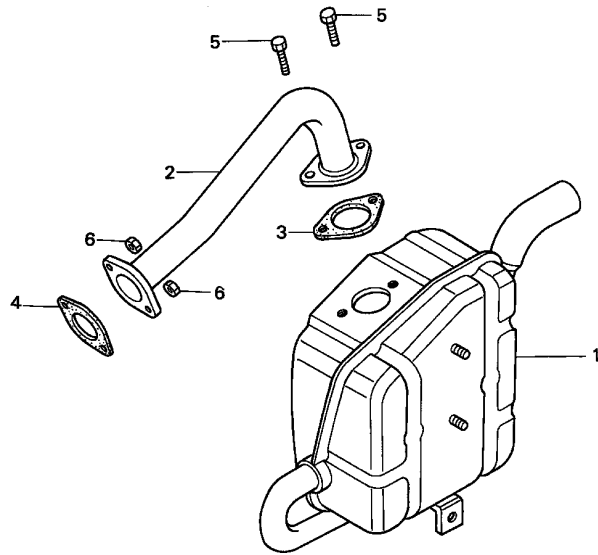

ZH80-E1608

Ref. No.	L.O.N.	(Relative ref. Number) Description	F.R.T.
1	3131C5	MUFFLER, EXHAUST	0.2
2	3131C9	PIPE, EXHAUST	0.2
3	3131B4	GASKET, EXHAUST MUFFLER	0.2

FR.

2

Ref. No.	Part No.	Description	Reqd. QTY				Serial No.	Parts catalogue code
			(1)	(2)	(3)	(4)		
				GX160K1				
1	18310-ZB6-C01	MUFFLER COMP.	1	-	-	-	-----	NJC1,SMJ
2	18330-ZB6-000	PIPE COMP., EX.	1	-	-	-	-----	NJC1,SMJ
3	18381-ZE1-800	GASKET, MUFFLER	1	-	-	-	-----	NJC1,SMJ
4	18381-ZH8-800	GASKET, MUFFLER	1	-	-	-	-----	NJC1,SMJ
5	92101-08020-0A	BOLT, HEX., 8X20	2	-	-	-	-----	NJC1,SMJ
6	94001-08000-0S	NUT, HEX., 8MM	2	-	-	-	-----	NJC1,SMJ

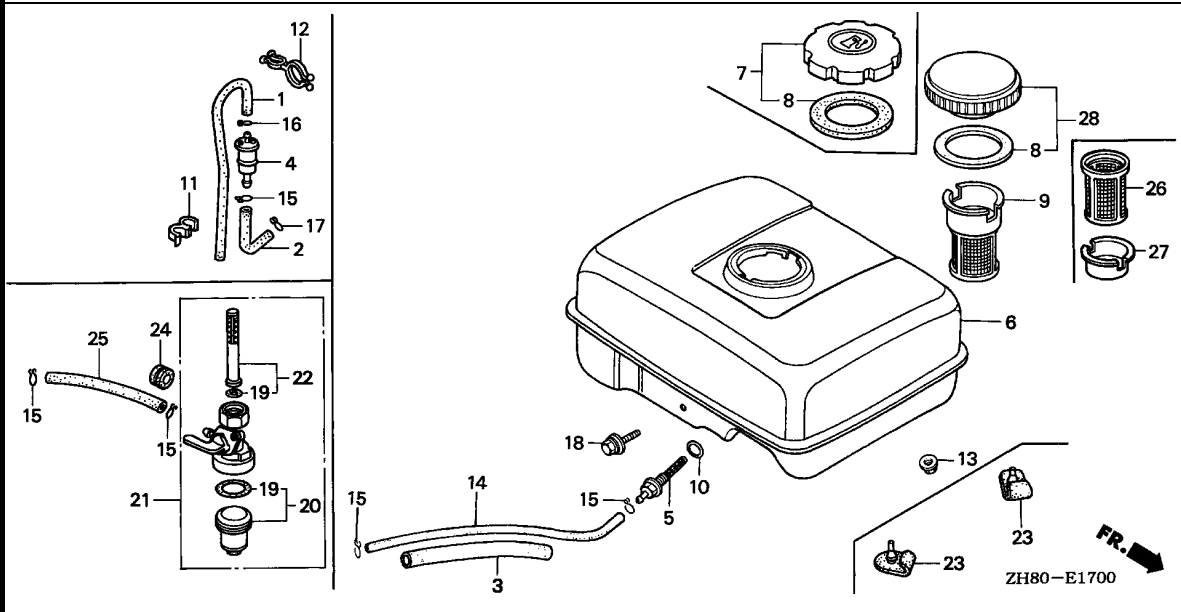

Ref. No.	L.O.N.	(Relative ref. Number) Description	F.R.T.
1	1111M9	TUBE, AIR VENT	0.1
2	3101G0	TUBE, FUEL STRAINER	0.1
5	3101H6	STRAINER, JOINT FUEL	0.2
6	3101H7	TANK, FUEL	0.2
9		(26)	
	3101A6	FILTER, FUEL	0.1
14	3101F1	TUBE, FUEL TANK	0.1
21	3101A3	COCK, FUEL	0.2
22	3101D5	SCREEN, FUEL STRAINER	0.2
25	3101F2	TUBE, FUEL COCK	0.1

2

Ref. No.	Part No.	Description	Reqd. QTY				Serial No.	Parts catalogue code
			(1)	GX160K1 (2)	(3)	(4)		
1	16198-ZG0-U00	TUBE A, AIR VENT	1	-	-	-	AR	
2	16199-KCR-000	TUBE	1	-	-	-	AR	
3	16854-ZH8-000	RUBBER, SUPPORTER (107MM) ...	1	-	-	-	HG1, HX, QA, QAX, QBT2, QCB2, QGR9, QI2, QSC9, QWM2, QWX2, QWX3, QX, QXC, QXE, QXF, QXS, QX22, QX7, RFR, RH, RTB2, SG24, SM12, SSSX2, SWX2, SX7, TX, VG24, VHA7, VMS7, VSD7, VWA, VX, VXE7, VXW, VXW1, WME2	
4	16910-ZG0-U02	STRAINER COMP., FUEL	1	-	-	-	AR	
5	16955-ZE1-000	JOINT, FUEL TANK	1	-	-	-	HG1, HX, QA, QAX, QBT2, QCB2, QGR9, QI2, QSC9, QWM2, QWX2, QWX3, QX, QXC, QXE, QXF, QXS, QX22, QX7, RFR, RH, RTB2, SG24, SM12, SSSX2, SWX2, SX7, TX, VG24, VMS7, VSD7, VWA, VX, VXE7, WME2	
6	17510-ZE1-020ZA	TANK COMP., FUEL *NH31*.....MCKINLEY WHITE	1	-	-	-	HG1, HX, QA, QAX, QBT2, QCB2, QGR9, QI2, QSC9, QX, QXC, QXE, QXF, QXS, QX22, QX7, RH, RTB2, SM12, SX7, TX, VMS7, VSD7, VWA, VX, VXE7, WME2	
	17510-ZE1-020ZF	*NH1*.....BLACK	1	-	-	-	QCB2, QSC9, QWM2, SG24, SM12, SSSX2, VG24, VWA2	
	17510-ZE1-020ZG	*NH105*...MAT BLACK (#15-#20)	1	-	-	-	QWX2, QWX3, SWX2, VSD7	
7	17620-ZH7-013	CAP COMP., FUEL FILLER	1	-	-	-	4705772 QBT2, QWX2, RTB2, SG24, SSSX2, VG24, WME2	
	17620-ZH7-023	CAP COMP., FUEL FILLER (BLACK)	1	-	-	-	3063878 4705772 HG1, HX, QA, QAX, QX, QXC, QXE, QXF, QXS, RH, TX, VWA, VX, QWM2, QWX3	
			1	-	-	-	4705773 HG1, QA, QAX, QBT2, QXF, QXS, VWA	
			1	-	-	-	8542059 QCB2, QGR9, QI2, QSC9, QX22, QX7, SM12, SWX2, SX7, VMS7, VSD7, VXE7	
			1	-	-	-	4705773 8542059 HX, QWX2, QX, QXC, QXE, RH, RTB2, SG24, SSSX2, TX, VG24, VX, WME2	
	17620-Z0T-814	CAP COMP., FUEL FILLER (CHROME PLATED)	1	-	-	-	8542060 HX, QCB2, QGR9, QI2, QSC9, QWX2, QX, QXC, QXE, QX22, QX7, RH, RTB2, SG24, SM12, SSSX2, SWX2, SX7, TX, VG24, VMS7, VSD7, VX, VXE7, WME2	
8	17631-329-003	PACKING, FUEL FILLER CAP (39X58X3)	1	-	-	-	3063877 HG1, HX, QA, QAX, QX, QXC, QXE, QXF, QXS, RH, TX, VWA, VX	

Ref. No.	Part No.	Description	Reqd. QTY				Serial No.	Parts catalogue code
			GX160K1					
			(1)	(2)	(3)	(4)		
(8)	17631-ZH7-003	PACKING, FUEL FILLER CAP (39X58X3)	1	-	-	-	-----	QBT2,QWM2,QWX3
			1	-	-	-	3063878	HG1,QA,QAX,QXF,QXS,VWA
			1	-	-	-	8542059	QCB2,QGR9,QI2,QSC9,QWX2,QX22,QX7,RTB2,SG24,SM12,SSX2,SWX2,SX7
			1	-	-	-	3063878	VG24,VMS7,VSD7,VXE7,WME2
	17631-ZOT-812	PACKING, FUEL FILLER CAP (39X62X3)	1	-	-	-	8542060	HX,QX,QXC,QXE,RH,TX,VX
			1	-	-	-	8542060	HX,QCB2,QGR9,QI2,QSC9,QWX2,QX,QXC,QXE,QX22,QX7,RH,RTB2,SG24
			1	-	-	-	8542060	SM12,SSX2,SWX2,SX7,TX,VG24,VMS7,VSD7,VX,VXE7,WME2
9	17672-ZE2-W01	FILTER, FUEL	1	-	-	-	-----	QA,SM12,SSX2,WME2
10	91353-671-004	O-RING, 14MM(NOK)	1	-	-	-	-----	HG1,HX,QA,QAX,QBT2,QCB2,QGR9,QI2,QSC9,QWM2,QWX2,QWX3,QX,QXC
			1	-	-	-	-----	QXE,QXF,QXS,QX22,QX7,RFR,RH,RTB2,SG24,SM12,SSX2,SWX2,SX7,TX
			1	-	-	-	-----	VG24,VHA7,VMS7,VSD7,VWA,VX,VXE7,VXW1,WME2
11	91403-750-800	CLIP, DOUBLE	1	-	-	-	-----	AR
12	91473-PA1-003	CLIP, WATER HOSE	1	-	-	-	-----	AR
13	94050-06000	NUT, FLANGE, 6MM	2	-	-	-	-----	HG1,HX,QA,QAX,QBT2,QCB2,QGR9,QI2,QSC9,QWM2,QWX2,QWX3,QX,QXC
			2	-	-	-	-----	QXE,QXF,QXS,QX22,QX7,RH,RTB2,SG24,SM12,SSX2,SWX2,SX7,TX,VG24
			2	-	-	-	-----	VMS7,VSD7,VWA,VX,VXE7,WME2
14	95001-45140-40	TUBE, FUEL, 4.5X140 (95001-45001-60M)	1	-	-	-	-----	HG1,HX,QA,QAX,QBT2,QCB2,QGR9,QI2,QSC9,QWM2,QWX2,QWX3,QX,QXC
			1	-	-	-	-----	QXE,QXF,QXS,QX22,QX7,RFR,RH,RTB2,SG24,SM12,SSX2,SWX2,SX7,TX
			1	-	-	-	-----	VG24,VHA7,VMS7,VSD7,VWA,VX,VXE7,VXW,VXW1,WME2
15	95002-02080	CLIP, TUBE (B8)	1	-	-	-	-----	AR
			2	-	-	-	-----	HG1,HX,QA,QAX,QBT2,QCB2,QGR9,QI2,QSC9,QWM2,QWX2,QWX3,QX,QXC
			2	-	-	-	-----	QXE,QXF,QXS,QX22,QX7,RFR,RH,RTB2,SG24,SM12,SSX2,SWX2,SX7,TX
			2	-	-	-	-----	VED7,VG24,VHA7,VMS7,VSD7,VWA,VX,VXE7,VXW,VXW1,WME2
16	95002-02100	CLIP, TUBE (B10)	1	-	-	-	-----	AR
17	95002-50000	CLIP, TUBE (C9)	1	-	-	-	-----	AR
18	95900-06025-00	BOLT, FLANGE, 6X25	1	-	-	-	2000037	HX,QA,QX,QXE,RH,TX,VX
	95701-06025-00	1	-	-	-	-----	HG1,QAX,QBT2,QCB2,QGR9,QI2,QSC9,QWM2,QWX2,QWX3,QXC,QXF,QXS
			1	-	-	-	-----	QX22,RTB2,SG24,SM12,SSX2,SWX2,VG24,VWA,WME2
			1	-	-	-	2000038	HX,QA,QX,QXE,RH,TX,VX
	90004-ZH7-003	BOLT, FLANGE, 6X29	1	-	-	-	-----	QX7,SX7,VMS7,VSD7,VXE7
19	16080-898-631	PACKING SET, COCK	1	-	-	-	-----	VED7
20	16081-471-831	CUP, FUEL STRAINER	1	-	-	-	-----	VED7
21	16950-898-632	COCK ASSY., FUEL	1	-	-	-	-----	VED7
22	16952-883-005	SCREEN SET	1	-	-	-	-----	VED7
23	50319-ZB2-000	RUBBER, TANK MOUNTING	2	-	-	-	-----	VED7
24	90854-ZB3-000	RUBBER, FUEL (9X15X20)	1	-	-	-	-----	VED7
25	95001-45095-40	TUBE, FUEL, 4.5X95 (95001-45001-60M)	1	-	-	-	-----	VED7
26	17672-880-000	FILTER, FUEL	1	-	-	-	-----	QSC9
			1	-	-	-	2468780	2827376 QA
27	17673-893-000	HOLDER, FUEL FILTER	1	-	-	-	-----	QSC9
			1	-	-	-	2468780	2827376 QA
28	17620-ZE2-W00	CAP COMP., FUEL FILLER (CHROME PLATED)	1	-	-	-	-----	3063877 HG1,HX,QA,QAX,QX,QXC,QXE,QXF,QXS,RH,TX,VWA,VX



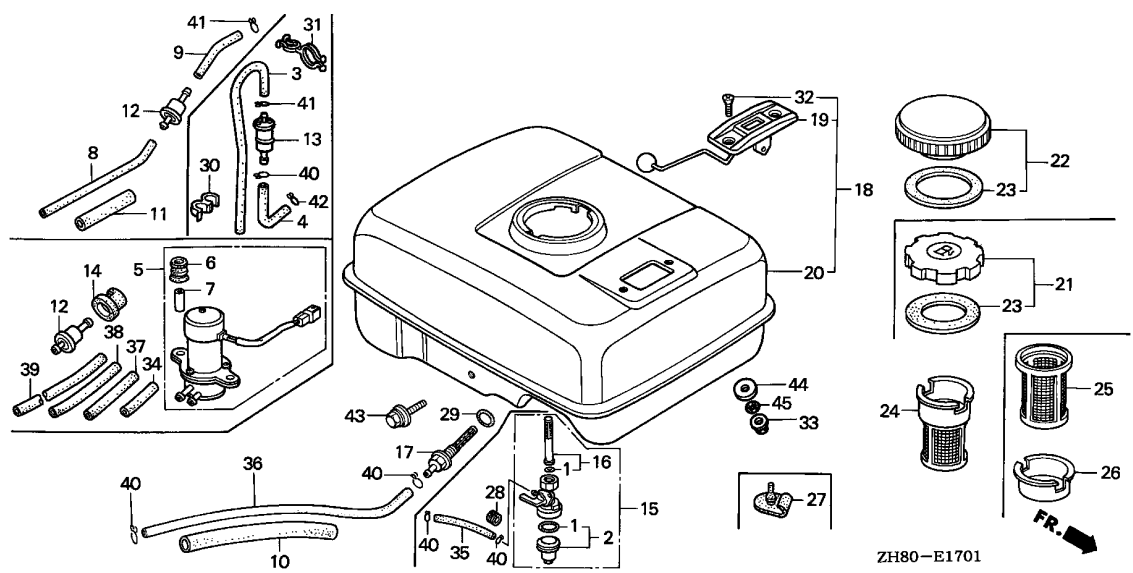

Ref. No.	L.O.N.	(Relative ref. Number) Description	F.R.T.
5	3101H9	PUMP, FUEL	0.2
13		(12)	
	3101H8	STRAINER, FUEL	0.1
15	3101A3	COCK, FUEL	0.2
16	3101D5	SCREEN, FUEL STRAINER	0.2
17	3101H6	STRAINER, JOINT FUEL	0.2
18	3101H7	TANK, FUEL	0.2
19	6171A1	METER UNIT, FUEL	0.1
24		(25)	
	3101A6	FILTER, FUEL	0.1
36	3101K5	TUBE, FUEL TANK(A)	0.2

ZH80-E1701

2

Ref. No.	Part No.	Description	Reqd. QTY				Serial No.	Parts catalogue code
			(1)	(2)	(3)	(4)		
1	16080-898-631	PACKING SET, COCK	1	-	-	-	EMA,EMA2,VED3	
2	16081-471-831	CUP, FUEL STRAINER	1	-	-	-	EMA,EMA2,VED3	
3	16198-ZG0-U00	TUBE A, AIR VENT	1	-	-	-	KR	
4	16199-KCR-000	TUBE	1	-	-	-	KR	
5	16700-679-083	PUMP ASSY., FUEL (COUPLER)	1	-	-	4259329	SKM	
	16700-ZA0-971	PUMP ASSY., FUEL (ELECTROMAGNETIC)	1	-	-	4259330	SKM	
6	16711-679-000	RUBBER, FUEL PUMP MOUNTING	2	-	-	-	SKM	
7	16712-657-300	COLLAR, FUEL PUMP DISTANCE	2	-	-	-	SKM	
8	16851-ZE1-000	TUBE A, FUEL	1	-	-	-	ST,STM	
9	16852-ZE1-000	TUBE B, FUEL	1	-	-	-	ST,STM	
10	16854-ZH8-000	RUBBER, SUPPORTER (107MM)	1	-	-	-	DS,DSP,HG12,HXQ,HX2,LAX2,LJ,LJC7,LJD,LJG,LMT,LSJ,LSS,LSS1,LTK LX2,NJ,NJG,NSJ,PX2,QAX2,QA2,QBC2,QGR2,QMX2,QM22,QSC2,QS2,QXC9 QXE2,QXF2,QXM1,QXQ,QXS2,QX2,RFR2,RH2,RMD,RNG,RSS1,RXE2,SCJ SHRY,SJ,SJC,SJC1,SJC5,SJG,SMJ,SMJ1,SMW2,SM11,SNX,SNX1,SSK1 SSK2,STA,STP,STQ,S1CY,TXC9,TX2,VA2,VEB2,VED5,VWA2,VW12,VXD VXD1,VXW2,VX2,WJP,WKT2,WMT	
			-	(1)	-	-		
11	16854-ZH8-810	RUBBER, SUPPORTER (50MM)	1	-	-	-	ST,STM	
12	16910-GB2-005	STRAINER COMP., FUEL	1	-	-	-	SKM	
	16952-952-003	STRAINER, FUEL	1	-	-	-	ST,STM	
13	16910-ZG0-U01	STRAINER COMP., FUEL	1	-	-	6330244	KR	
	16910-ZG0-U02		1	-	-	6330245	KR	
14	16915-GB2-000	SUSPENSION, STRAINER	1	-	-	-	SKM	
15	16950-898-632	COCK ASSY., FUEL	1	-	-	-	EMA	
			1	-	-	8018247	EMA2,VED3	

Ref. No.	Part No.	Description	Reqd. QTY				Serial No.	Parts catalogue code
			(1)	(2)	(3)	(4)		
15)	16950-898-633	COCK ASSY., FUEL	1	-	-	-	8018248 ----- EMA2,VED3	
16	16952-883-005	SCREEN SET	1	-	-	-	----- EMA	
			1	-	-	-	8010247 EMA2	
			1	-	-	-	8018247 VED3	
	16952-GG2-731	1	-	-	-	8010248 ----- EMA2	
			1	-	-	-	8018248 ----- VED3	
17	16955-ZE1-000	JOINT, FUEL TANK	1	-	-	-	----- DS,DSP,HG12,HXQ,HX2,LAX2,LJ,LJC7,LJD,LJG,LMT,LSJ,LSS,LSS1,LTK,LX2,NJ,NJG,NSJ,PX2,QAX2,QA2,QBC2,QGR2,QMX2,QMZ2,QSC2,QS2,QXC9,QXE2,QXF2,QXM1,QXQ,QXS2,QX2,RFR2,RH2,RMD,RNG,RSS1,RXE2,SCJ,SHRY,SJ,SJC,SJC1,SJC5,SJG,SMJ,SMJ1,SMW2,SM11,SNX,SNX1,SSK1,SSK2,STA,STP,STQ,S1CY,TXC9,TX2,VA2,VEB2,VED5,VWA2,VXD,VXD1,VX2,WJP,WKT2,WMT	
18	17500-ZE1-813ZA	TANK ASSY., FUEL (GAUGE) *NH31*.....MCKINLEY WHITE	1	-	-	-	----- LJD,LJG,LMT,LSJ,LSS,LSS1,LTK,NJG,NSJ,QSC2,RSS1,SJG,SMJ,SMJ1,SNX,SNX1,VED5	
19	17505-ZE1-013	GAUGE ASSY., FUEL	1	-	-	-	----- LJD,LJG,LMT,LSJ,LSS,LSS1,LTK,NJG,NSJ,QSC2,RSS1,SJG,SMJ,SMJ1,SNX,SNX1,VED5	
20	17510-ZE1-020ZA	TANK COMP., FUEL *NH31*.....MCKINLEY WHITE	1	-	-	-	----- DS,DSP,HG12,LAX2,LJ,LJC7,NJ,QAX2,QBC2,QGR2,QMX2,QMZ2,QS2,QXC9,QXM1,RMD,RNG,RXE2,SCJ,SHRY,SJ,SJC,SJC1,SJC5,SMW2,SM11,STA,STP,STQ,S1CY,TXC9,VA2,VEB2,WJP,WKT2,WMT	
	17510-ZE1-020ZB	*R8*.....BRIGHT RED	1	-	-	-	----- HXQ,HX2,LX2,PX2,QA2,QXE2,QXF2,QXQ,QXS2,QX2,RH2,TX2,VX2	
	17510-ZE1-020ZF	*NH1*.....BLACK	1	-	-	-	----- HXQ,HX2,LX2,PX2,QA2,QMX2,QMZ2,QXC9,QXE2,QXF2,QXQ,QXS2,QX2,RH2,SSK1,SSK2,TX2,VX2	
	17510-ZE1-020ZG	*NH105*...MAT BLACK (#15-#20)	1	-	-	-	----- VWA2	
	17510-ZE1-020ZJ	*T74*.....DENYO RED	1	-	-	-	----- VXD,VXD1	
	17510-ZE1-020ZN	*R280*.....POWER RED	1	-	-	-	----- HX2,LX2,QA2,QXE2,QXF2,QXQ,QXS2,QX2,RH2,TX2,VX2	
21	17620-ZH7-013	CAP COMP., FUEL FILLER	1	(1)	-	-	3063878 4705772 DS,DSP,HXQ,HX2,LJ,LJD,LMT,LTK,LX2,L1,PX2,QA2,QXE2,QXF2,QXQ,QXS2,QX2,Q1,RH2,RMD,R1,SCJ,SJ,SMJ,SMJ1,STA,STP,STQ,S1,TX2,T1,VX2,W1	
			1	-	-	-	4705772 HG12,LAX2,LJC7,LJG,LSS,LSS1,NJ,NJG,NSJ,QAX2,QGR2,QMX2,QMZ2,QSC2,QXC9,RNG,SJC,SJC1,SJC5,SJG,SMW2,SNX,SNX1,SSK1,SSK2,TXC9,VA2,VEB2,VED5,VWA2,VXD,VXD1,WJP,WKT2,WMT	
	17620-ZH7-023	CAP COMP., FUEL FILLER (BLACK)	1	(1)	-	-	3063878 ----- H1,U1,V1	
			1	(1)	-	-	4705773 ----- DS,DSP,HXQ,LAX2,LJD,LMT,LSS,LSS1,LTK,PX2,QXQ,Q1,RNG,R1,SJC,SSK2,STA,STP,S1,T1,VEB2,W1	
			1	(1)	-	-	4705773 8542059 HG12,HX2,LJ,LJC7,LJG,LX2,L1,NJ,NJG,NSJ,QAX2,QA2,QGR2,QMX2,QMZ2,QSC2,QXC9,QXE2,QXF2,QXS2,QX2,RH2,RMD,SCJ,SJ,SJC1,SJC5,SJG,SMJ,SMJ1,SMW2,SNX,SNX1,SSK1,STQ,TXC9,TX2,VA2,VED5,VWA2,VXD,VX2,WJP,WKT2,WMT	
			1	-	-	-	----- LSJ	
			1	-	-	-	8542059 QS2,QXM1,RSS1,RXE2,SHRY,SM11,S1CY	
			1	-	-	-	8627838 QBC2	
			1	-	-	-	4705773 8627838 VXD1	
	17620-Z0T-814	CAP COMP., FUEL FILLER (CHROME PLATED)	1	(1)	-	-	8542060 ----- HG12,HX2,LJ,LJC7,LJG,LX2,L1,NJ,NJG,NSJ,QAX2,QA2,QGR2,QMX2,QMZ2,QSC2,QS2,QXC9,QXE2,QXF2,QXM1,QXS2,QX2,RH2,RMD,RSS1,RXE2,SCJ,SHRY,SJ,SJC1,SJC5,SJG,SMJ,SMJ1,SMW2,SM11,SNX,SNX1,SSK1,STQ,S1CY,TXC9,TX2,VA2,VED5,VWA2,VXD,VX2,WJP,WKT2,WMT	
			1	-	-	-	8627839 ----- QBC2,VXD1	
22	17620-890-010	CAP COMP., FUEL FILLER	-	(1)	-	-		



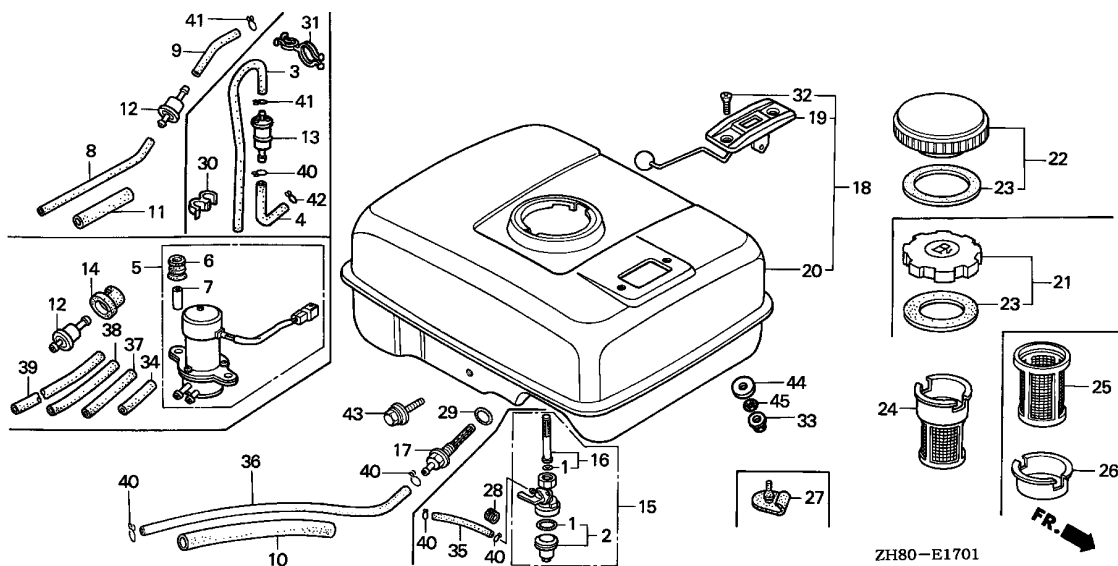

ZH80-E1701

Ref. No.	Part No.	Description	Reqd. QTY				Serial No.	Parts catalogue code
			(1)	(2)	(3)	(4)		
22)	17620-ZE2-W00	CAP COMP., FUEL FILLER (CHROME PLATED)	1	-	-	-	3063877	DS,DSP,HXQ,HX2,LJ,LJD,LMT,LTK,LX2,PX2,QA2,QXE2,QXF2,QXQ,QXS2,QX2,RH2,RMD,SCJ,SJ,SMJ,SMJ1,STA,STP,STQ,TX2,VX2
23	17631-329-003	PACKING, FUEL FILLER CAP (39X58X3)	1	-	-	-	3063877	DS,DSP,HXQ,HX2,LJ,LJD,LMT,LTK,LX2,PX2,QA2,QXE2,QXF2,QXQ,QXS2,QX2,RH2,RMD,SCJ,SJ,SMJ,SMJ1,STA,STP,STQ,TX2,VX2
	17631-ZH7-003	1	(1)	-	-	3063878	DS,DSP,HXQ,H1,LJD,LMT,LTK,PX2,QXQ,Q1,R1,STA,STP,S1,T1,U1,V1,W1
			1	(1)	-	-	3063878	HX2,LJ,LX2,L1,QA2,QXE2,QXF2,QXS2,QX2,RH2,RMD,SCJ,SJ,SMJ,SMJ1,STQ,TX2,VX2
			1	-	-	-	8542059	LAX2,LSJ,LSS,LSS1,RNG,SJC,SSK2,VEB2
			1	-	-	-	8542059	HG12,LJC7,LJG,NJ,NJG,NSJ,QAX2,QGR2,QMX2,QMZ2,QSC2,QS2,QXC9,QXM1,RSS1,RXE2,SHRY,SJC1,SJC5,SJG,SMW2,SM11,SNX,SNX1,SSK1,S1CY,TXC9,VA2,VED5,VWA2,VXD,WJP,WKT2,WMT
	17631-Z0T-812	PACKING, FUEL FILLER CAP (39X62X3)	1	(1)	-	-	8542060	QBC2,VXD1
			1	-	-	-	8627839	QBC2,VXD1
24	17672-ZE2-W00	FILTER, FUEL	1	-	-	-	2468779	DS,DSP,LJ,LMT,LTK,SJ,SMJ,SMJ1,STA,STP,STQ
			-	(1)	-	-	2468779	

Ref. No.	Part No.	Description	Reqd. QTY				Serial No.	Parts catalogue code
			GX160K1 (1) (2) (3) (4)					
24)	17672-ZE2-W01	FILTER, FUEL	1	-	-	-	LJD,LJG,LSJ,LSS,LSS1,NJ,NJG,NSJ,QBC2,QMX2,QMZ2,QSC2,QXM1,RMD RNG,RSS1,SHRY,SJC,SJG,SMW2,SM11,SNX,SNX1,SSK1,SSK2,S1CY,VED5 WJP,WKT2	
			1	-	-	2827377	DS,DSP,LJ,LMT,LTK,QA2,SCJ,SJ,SMJ,SMJ1,STA,STP,STQ	
			1	-	-	4269563	VXD,VXD1	
			1	-	-	5060213	LJC7,SJC1,SJC5	
			-	(1)	-	2827377		
	17670-ZH8-D01	FILTER COMP., FUEL	1	-	-	4269563	VXD,VXD1	
25	17672-880-000	FILTER, FUEL	1	-	-	5060214	LJC7,SJC1,SJC5	
			1	-	-	2827376	QA2	
			1	-	-	2468780	DS,DSP,LJ,LMT,LTK,SCJ,SJ,SMJ,SMJ1,STA,STP,STQ	
			-	(1)	-	2468780	2827376	
26	17673-893-000	HOLDER, FUEL FILTER	1	-	-	5060214	LJC7,SJC1,SJC5	
			1	-	-	2827376	QA2	
			1	-	-	2468780	DS,DSP,LJ,LMT,LTK,SCJ,SJ,SMJ,SMJ1,STA,STP,STQ	
			-	(1)	-	2468780	2827376	
27	50319-ZB2-000	RUBBER, TANK MOUNTING	2	-	-		VED3	
28	90854-ZB2-000	RUBBER, FUEL (9X15X10)	1	-	-	4795103	EMA,EMA2,VED3	
	90854-ZB3-000	RUBBER, FUEL (9X15X20)	1	-	-		EMA,EMA2,VED3	
29	91353-671-004	O-RING, 14MM(NOK)	1	-	-		DS,DSP,HG12,HXQ,HX2,LAX2,LJ,LJC7,LJD,LJG,LMT,LSJ,LSS,LSS1,LTK LX2,NJ,NJG,NSJ,PX2,QAX2,QA2,QBC2,QGR2,QMX2,QMZ2,QSC2,QS2,QXC9 QXE2,QXF2,QXM1,QXQ,QXS2,QX2,RFR2,RH2,RMD,RNG,RSS1,RXE2,SCJ SHRY,SJ,SJC,SJC1,SJC5,SJG,SMJ,SMJ1,SMW2,SM11,SNX,SNX1,SSK1 SSK2,STA,STP,STQ,S1CY,TXC9,TX2,VA2,VEB2,VED5,VWA2,VXD,VXD1 VXW2,VX2,WJP,WKT2,WMT	
			-	(1)	-			
30	91403-750-800	CLIP, DOUBLE	1	-	-		KR	
31	91473-PA1-003	CLIP, WATER HOSE	1	-	-		KR	
32	93600-05010-0A	SCREW, FLAT, 5X10	2	-	-		LJD,LJG,LMT,LSJ,LSS,LSS1,LTK,NJG,NSJ,QSC2,RSS1,SJG,SMJ,SMJ1 SNX,SNX1,VED5	
			-	(2)	-			
	93600-06010-0A	SCREW, FLAT, 6X10	2	-	-		QSC2	
33	94050-06000	NUT, FLANGE, 6MM	2	-	-		DS,DSP,HG12,HXQ,HX2,LAX2,LJ,LJC7,LJD,LJG,LMT,LSJ,LSS,LSS1,LTK LX2,NJ,NJG,NSJ,PX2,QAX2,QA2,QBC2,QGR2,QMX2,QMZ2,QSC2,QS2,QXC9 QXE2,QXF2,QXM1,QXQ,QXS2,QX2,RH2,RMD,RNG,RSS1,RXE2,SCJ,SHRY,SJ SJC,SJC1,SJC5,SJG,SMJ,SMJ1,SMW2,SM11,SNX,SNX1,SSK1,SSK2,STA STP,STQ,S1CY,TXC9,TX2,VA2,VEB2,VED5,VWA2,VXD,VXD1,VXW2,VX2,WJP WKT2,WMT	
			-	(2)	-			
34	95001-45040-40	TUBE, FUEL, 4.5X40 (95001-45001-60M)	1	-	-		SKM	
35	95001-45095-40	TUBE, FUEL, 4.5X95 (95001-45001-60M)	1	-	-		VED3	
	95001-45180-40	TUBE, FUEL, 4.5X180 (95001-45001-60M)	1	-	-		EMA,EMA2	
36	95001-45140-40	TUBE, FUEL, 4.5X140 (95001-45001-60M)	1	-	-		DS,DSP,HG12,HXQ,HX2,LAX2,LJ,LJC7,LJD,LJG,LMT,LSJ,LSS,LSS1,LTK LX2,NJ,NJG,NSJ,PX2,QAX2,QA2,QBC2,QGR2,QMX2,QMZ2,QSC2,QS2,QXC9 QXE2,QXF2,QXM1,QXQ,QXS2,QX2,RFR2,RH2,RMD,RNG,RSS1,RXE2,SCJ SHRY,SJ,SJC,SJC1,SJC5,SJG,SMJ,SMJ1,SMW2,SM11,SNX,SNX1,SSK1 SSK2,STA,STP,STQ,S1CY,TXC9,TX2,VA2,VEB2,VED5,VWA2,VW12,VXD VXD1,VXW2,VX2,WJP,WKT2,WMT	
			-	(1)	-			



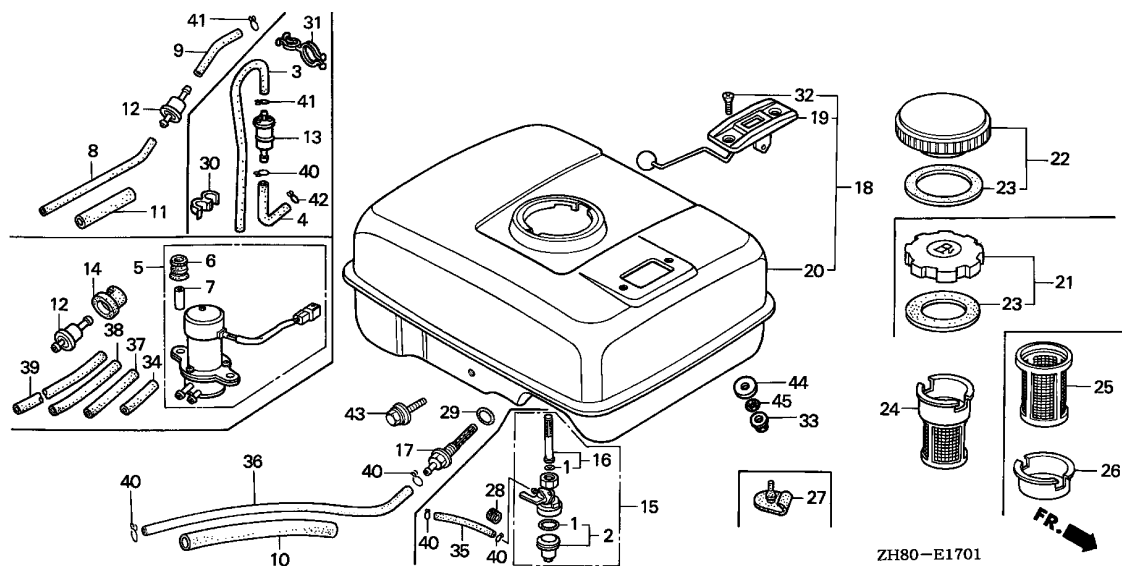

Ref. No.	Part No.	Description	Reqd. QTY				Serial No.	Parts catalogue code
			(1)	(2)	(3)	(4)		
37	95001-45180-40	TUBE, FUEL, 4.5X180 (95001-45001-60M)	1	-	-	-	-----	SKM
38	95001-45240-40	TUBE, FUEL, 4.5X240 (95001-45001-60M)	1	-	-	-	-----	SKM
39	95001-45770-40	TUBE, FUEL, 4.5X770 (95001-45001-60M)	1	-	-	-	-----	SKM
40	95002-02080	CLIP, TUBE (B8)	1	-	-	-	-----	KR
			2	-	-	-	-----	DS, DSP, EMA, EMA2, HG12, HXQ, HX2, LAX2, LJ, LJC7, LJD, LJG, LMT, LSJ, LSS, LSS1, LTK, LX2, NJ, NJG, NSJ, PX2, QAX2, QA2, QBC2, QGR2, QMX2, QMZ2, QSC2, QS2, QXC9, QXE2, QXF2, QXM1, QXQ, QXS2, QX2, RFR2, RH2, RMD, RNG, RSS1, RXE2, SCJ, SHRY, SJ, SJC, SJC1, SJC5, SJG, SMJ, SMJ1, SMW2, SM11, SNX, SNX1, SSK1, SSK2, STA, STP, STQ, S1CY, TXC9, TX2, VA2, VEB2, VED3, VED5, VWA2, VW12, VXD, VXD1, VXW2, VX2, WJP, WKT2, WMT
			-	(2)	-	-	-----	
41	95002-02100	CLIP, TUBE (B10)	1	-	-	-	-----	KR, ST, STM
42	95002-50000	CLIP, TUBE (C9)	1	-	-	-	-----	KR
43	95900-06025-00	BOLT, FLANGE, 6X25	1	-	-	-	-----	DS, DSP, LJ, SJ, STA, STP, STQ
	95701-06025-00	1	-	-	-	-----	HG12, HXQ, HX2, LAX2, LJC7, LJD, LJG, LMT, LSJ, LSS, LSS1, LTK, LX2, NJ, NJG, NSJ, PX2, QAX2, QA2, QGR2, QMX2, QMZ2, QSC2, QXC9, QXE2, QXF2, QXM1, QXQ, QXS2, QX2, RH2, RMD, RNG, RSS1, SCJ, SHRY, SJC, SJC1, SJC5, SJG, SMJ, SMJ1, SMW2, SM11, SNX, SNX1, SSK1, SSK2, S1CY, TXC9, TX2, VA2, VEB2, VED5, VWA2, VXD, VXD1, VX2, WKT2, WMT
	90004-ZH7-003	BOLT, FLANGE, 6X29	1	-	-	-	-----	QS2, WJP
44	90404-680-000	WASHER, 6.5X25X1.5	2	-	-	-	6745959	QMX2
45	91319-ME5-003	O-RING, 5.5X1.4	2	-	-	-	6745959	QMX2

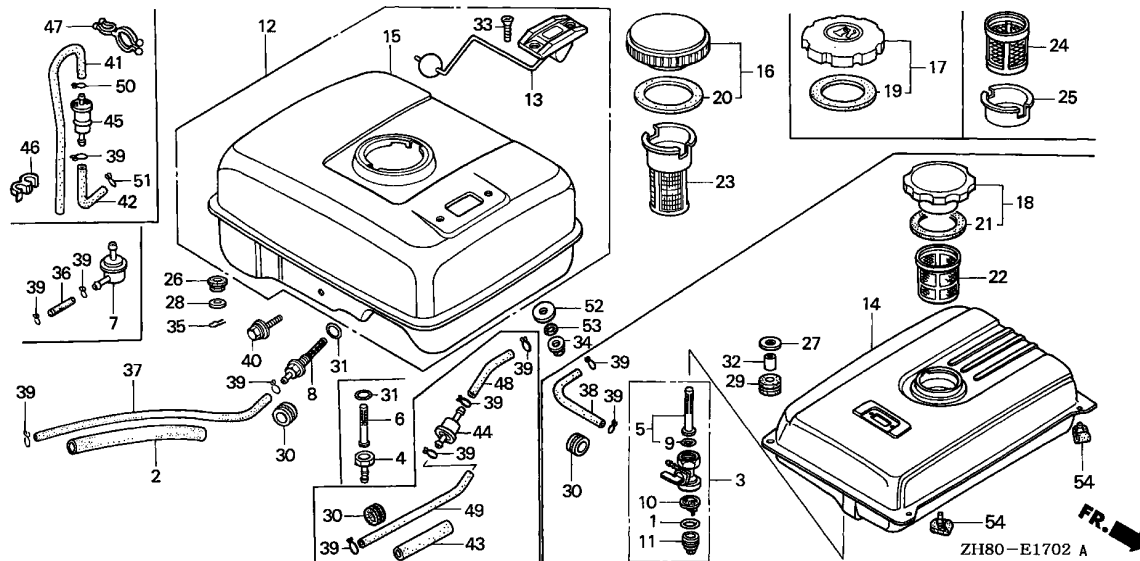

Ref. No.	L.O.N.	(Relative ref. Number) Description	F.R.T.
3	3101A3	COCK, FUEL	0.2
5	3101D5	SCREEN, FUEL STRAINER	0.2
8	3101H6	STRAINER, JOINT FUEL	0.2
10	3101A7	FILTER, CUP	0.2
12		(14)	
	3101H7	TANK, FUEL	0.2
13	6171A1	METER UNIT, FUEL	0.1
22		(23,24)	
	3101A6	FILTER, FUEL	0.1
37	3101K5	TUBE, FUEL TANK(A)	0.2
41	1111M9	TUBE, AIR VENT	0.1
45		(7,44)	
	3101K6	STRAINER, FUEL(A)	0.2

Ref. No.	Part No.	Description	Reqd. QTY				Serial No.	Parts catalogue code
			(1)	(2)	(3)	(4)		
1	16173-001-004	PACKING, FUEL STRAINER CUP ..	1	-	-	-	VSB1,VSG,VSW,VS3,VS4	
2	16854-ZH8-000	RUBBER, SUPPORTER (107MM) ...	1	-	-	-	BL,EN,ET,ETX,HH,HHQ4,HH26,HXE,HXE2,HXE8,HXU,HX26,HX4,KTA,LAX,LD,LDB1,LDB3,LDM,LD4,LH,LHB3,LHQ4,LHW,LSJ4,LSS4,LTA,LVL,LW2,LX,LXU,LX26,LX4,NW,PH,PHM,PHU,PM,PM2,PX,PXU,QA,QAB1,QAB3,QA26,QBT6,QBU2,QD,QE,QFE4,QH,QHE,QHP1,QHQ4,QH26,QKA4,QM,QMC6,QMC8,QMD6,QME4,QMH,QNT,QNT2,QNT4,QNZ,QP,QPU,QT,QVL,QWA4,QXB,QXB1,QXC6,QXE4,QXE6,QXE8,QXU,QXW,QXW2,QX26,QX4,QZ,RAC,RD,RD4,RHQ4,RH26,RMB4,RSK,RX,RXE,RXE4,RXU,RX4,SAC,SAD2,SD,SDB1,SDB3,SDN,SDS,SDS2,SDS3,SD16,SD4,SE,SEE,SH,SHM,SHQ4,SHR4,SMB4,SMC7,SMC9,SMX4,SM14,STA,SWG4,SWX,SWX2,SWX4,SW2,SX,SXB,SXE,SXE4,SXS4,SXU,SX4,TH,THU,TXU,TX26,TX4,UH,UX,UXU,VA,VEBM,VED,VED1,VED6,VH,VHQ4,VMS4,VS,VSD,VSD1,VSX,VSX1,VSX3,VS1,VS17,VTD,VTD1,VXE,VXE4,VXE6,VXG,VXM,VXU,VXU1,VX26,VX4,WDA6,WKD6,WKT4,WKT6,WMB0,WME4	
3	16950-ZB4-015	COCK ASSY., FUEL	1	(1)	1	-	VSB1,VSG,VSW,VS3,VS4	
4	16950-732-000	JOINT, FUEL	1	-	-	-	EN,ET,ETX	
5	16952-ZB4-005	SCREEN, FUEL STRAINER	1	-	-	-	VSB1,VSG,VSW,VS3,VS4	
6	16952-883-005	SCREEN SET	1	-	-	-	EN,ET,ETX	
7	16953-883-691	STRAINER, FUEL	1	-	-	-	PHU,THU	



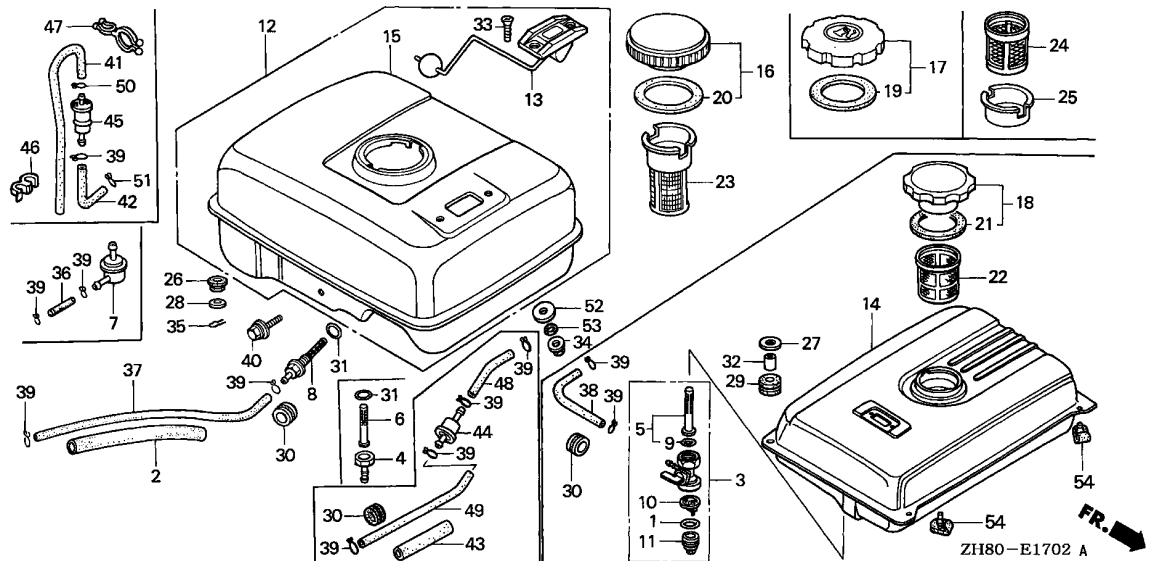

2

Ref. No.	Part No.	Description	Reqd. QTY				Serial No.	Parts catalogue code
			(1)	(2)	(3)	(4)		
8	16955-ZE1-000	JOINT, FUEL TANK	1	-	-	-	BL,HH,HHQ4,HH26,HXE,HXE2,HXE8,HXU,HX26,HX4,KTA,LAX,LD,LDB1,LDB3,LDM,LD4,LH,LHB3,LHQ4,LHW,LSJ4,LSS4,LTA,LVL,LW2,LX,LXU,LX26,LX4,NW,PH,PHM,PHU,PM,PM2,PX,PXU,QA,QAB1,QAB3,QA26,QBT6,QBU2,QD,QE,QFE4,QH,QHE,QHP1,QHQ4,QH26,QKA4,QM,QMC6,QMC8,QMD6,QME4,QMH,QNT,QNT2,QNT4,QNZ,QP,QPU,QT,QVL,QWA4,QXB,QXB1,QXC6,QXE4,QXE6,QXE8,QXU,QXW,QXW2,QX26,QX4,QZ,RAC,RD,RD4,RHQ4,RH26,RMB4,RSK,RX,RXE,RXE4,RXU,RX4,SAC,SAD2,SD,SDB1,SDB3,SDN,SDS,SDS2,SDS3,SD16,SD4,SE,SEE,SH,SHM,SHQ4,SHR4,SMB4,SMC7,SMC9,SMX4,SM14,STA,SWX,SWX2,SWX4,SW2,SX,SXB,SXE,SXE4,SXS4,SXU,SX4,TH,THU,TXU,TX26,TX4,UH,UX,UXU,VA,VEBM,VED,VED1,VED6,VH,VHQ4,VMS4,VS,VSD,VSX,VSX1,VSX3,VS1,VTD,VTD1,VXE,VXE4,VXE6,VXG,VXM,VXU,VXU1,VX26,VX4,WDA6,WKD6,WKT4,WKT6,WMB0,WME4	
9	16958-397-771	O-RING	1	(1)	1	-	VSB1,VSG,VSW,VS3,VS4	
10	16959-471-831	FILTER, CUP	1	-	-	-	VSB1,VSG,VSW,VS3,VS4	
11	16967-GA6-671	CUP, FUEL STRAINER	1	-	-	-	VSB1,VSG,VSW,VS3,VS4	
12	17500-ZE1-813ZA	TANK ASSY., FUEL (GAUGE) *NH31*.....MCKINLEY WHITE	1	-	-	-	VSX3,VXG	
13	17505-ZE1-013	GAUGE ASSY., FUEL	1	(1)	-	-	VSX3,VXG	
	17505-ZB2-003	METER ASSY., FUEL	1	(1)	-	-	VSB1,VSG,VSW,VS3,VS4	
14	17510-ZB4-000ZA	TANK COMP., FUEL *NH31*.....MCKINLEY WHITE	1	-	-	-	VSW	
	17510-ZB4-000ZB	*R8*.....BRIGHT RED	1	-	-	8457952	VSG	
	17510-ZB4-000ZH	*R280*.....POWER RED	1	-	-	8457953	VSG	

Ref. No.	Part No.	Description	Reqd. QTY				Serial No.	Parts catalogue code
			GX160K1					
			(1)	(2)	(3)	(4)		
15	17510-ZE1-020ZA	TANK COMP., FUEL *NH31*.....MCKINLEY WHITE	1	-	-	-	-----	BL,HH,HHQ4,HH26,HXE,HXE2,HXE8,HXU,HX26,HX4,KTA,LAX,LD,LDB1 LDB3,LDM,LD4,LH,LHB3,LHQ4,LHW,LSJ4,LSS4,LTA,LVL,LW2,LX,LXU LX26,LX4,NW,PH,PHM,PHU,PM,PM2,PX,PXU,QA,QAB1,QAB3,QA26,QBT6 QBU2,QD,QE,QFE4,QH,QHE,QHP1,QHQ4,QH26,QKA4,QM,QMC6,QMC8,QMD6 QME4,QMH,QNT,QNT2,QNT4,QNZ,QP,QPU,QT,QVL,QWA4,QXB,QXB1,QXC6 QXE4,QXE6,QXE8,QXU,QXW,QXW2,QX26,QX4,QZ,RAC,RD,RD4,RHQ4,RH26 RMB4,RSK,RX,RXE,RXE4,RXU,RX4,SAC,SAD2,SD,SDB1,SDB3,SDN,SDS SDS2,SDS3,SD16,SD4,SE,SEE,SH,SHM,SHQ4,SHR4,SMB4,SMC7,SMC9,SMX4 SM14,STA,SWX,SW2,SX,SXB,SXE,SXE4,SXS4,SXU,SX4,TH,THU,TXU,TX26 TX4,UH,UX,UXU,VA,VEBM,VED1,VED6,VH,VHQ4,VMS4,VPM5,VS,VSD,VTD VTD1,VXE,VXE4,VXE6,VXM,VXU,VXU1,VX26,VX4,WDA6,WKD6,WKT4,WKT6 WMB0,WME4
	17510-ZE1-020ZB	*R8*.....BRIGHT RED	1	-	-	-	-----	QXW,VS1
	17510-ZE1-020ZF	*NH1*.....BLACK	1	-	-	-	-----	QBU2,QMC8,QNT2,QX4,RD,SMB4,SMX4,SM14,TX4,VED,VX4
	17510-ZE1-020ZG	*NH105*...MAT BLACK (#15-#20)	1	-	-	-	-----	SWX2,SWX4,VX4
	17510-ZE1-020ZK	*Y131*.....LIGHTNING YELLOW	1	-	-	-	-----	VSX1
	17510-ZE1-020ZL	*T77*.....SEC WINE RED	1	-	-	-	-----	VSX,VS3,VS4
	17510-ZF1-T00ZA	*NH31*.....MCKINLEY WHITE	-	-	1	-	-----	
16	17620-ZE2-W00	CAP COMP., FUEL FILLER (CHROME PLATED)	1	(1)	1	-	-----	H1,LDB1,LDB3,QAB1,QIH1,QXB1,SDB1,SDB3,SDS2,SDS3,U1,VIH1,WIH1
	17620-890-010	CAP COMP., FUEL FILLER	1	-	-	-	-----	8382120 BL,LHB3,LVL,QAB3,QVL
	17620-ZE2-W00	CAP COMP., FUEL FILLER (CHROME PLATED)	-	-	1	-	-----	UIH
	17620-ZE2-W11	1	-	-	-	3394951	8382120 QT
	17620-ZH7-013	CAP COMP., FUEL FILLER	1	(1)	-	-	3063878	8542059 BL,LHB3,LVL,QAB3,QT,QVL
17	17620-ZH7-013	CAP COMP., FUEL FILLER	1	(1)	-	-	3063878	4705772 EN,ET,ETX,HH,KTA,LAX,LD,LH,LTA,LW2,LX,L1,PH,PHU,PM,PM2,PX,QA QD,QE,QH,QHE,QM,QNT,QNZ,QXB,QXW,QZ,Q1,RAC,RD,RSK,RX,RXE,R1,SAC SD,SDS,SE,SEE,SH,STA,SWX,SW2,SX,SXB,SXE,S1,TH,THU,T1,UH,UX,VA VEBM,VED,VED1,VH,VS,VSD,VSX,VXS1,VS1,VXE,VXG,VXU,W1
			1	-	-	-	4705772	HHQ4,HH26,HXE,HX26,HX4,LD4,LHQ4,LX26,LX4,QA26,QBT6,QBU2,QHP1 QHQ4,QH26,QKA4,QMC6,QMC8,QMD6,QME4,QMH,QNT2,QP,QPU,QXC6,QXE4 QXE6,QXW2,QX26,QX4,RD4,RHQ4,RH26,RMB4,RXE4,RX4,SAD2,SDN,SD16 SD4,SHQ4,SMB4,SMC7,SMC9,SXE4,SX4,TX26,TX4,VHQ4,VMS4,VXE4,VX26 VX4,WMB0
			1	-	-	-	3063878	3394950 QT
			-	(1)	-	-	3063878	V1
	17620-ZH7-023	CAP COMP., FUEL FILLER (BLACK)	1	(1)	-	-	4705773	EN,ET,ETX,HXE,LAX,LD4,LTA,PH,PHU,PM,PM2,QA,QBU2,QM,QNT2,QXB QXW2,QZ,Q1,RAC,R1,SAC,SAD2,SDN,SEE,SMB4,STA,SWX,SW2,SXB,S1,TH THU,T1,UH,UX,VA,VH,VHQ4,VS,VS1,VXE,VXG,VX26,W1
			1	(1)	-	-	4705773	8542059 HH,HHQ4,HH26,HX26,HX4,KTA,LD,LH,LHQ4,LW2,LX,LX26,LX4,L1,PX QA26,QBT6,QD,QE,QH,QHE,QHP1,QHQ4,QH26,QKA4,QMC6,QMC8,QMD6,QME4 QMH,QNT,QNZ,QP,QPU,QXC6,QXE4,QXE6,QXW,QX26,QX4,RD,RD4,RHQ4 RH26,RMB4,RSK,RX,RXE,RXE4,RX4,SD,SDS,SD16,SD4,SE,SH,SHQ4,SMC7 SMC9,SX,SXE,SXE4,SX4,TX26,TX4,VEBM,VED,VED1,VMS4,VSD,VSX,VXS1 VXE4,VXU,VX4,WMB0
			1	-	-	-	-----	LDM,LHW,LSS4,NW,SHR4,SWX2,VTD,VTD1,VXE6
			1	-	-	-	8542059	HXE2,HXE8,HXU,LSJ4,LXU,PHM,PXU,QFE4,QNT4,QWA4,QXE8,QXU,RXU,SHM SMX4,SM14,SWX4,SXS4,SXU,TXU,UXU,VED6,VXS3,VXM,VXU1,WDA6,WKD6 WKT4,WKT6,WME4



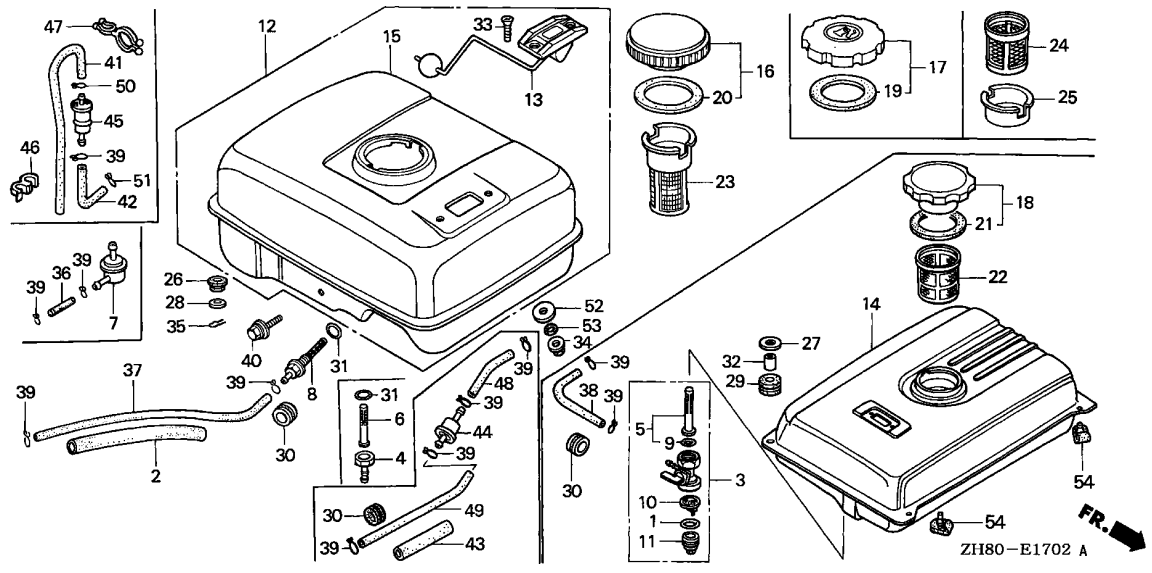

Ref. No.	Part No.	Description	Reqd. QTY	Serial No.	Parts catalogue code
			GX160K1 (1) (2) (3) (4)		
17)	17620-Z0T-814	CAP COMP., FUEL FILLER (CHROME PLATED)	1 (1) - -	8542060	----- BL,HH,HHQ4,HH26,HXE2,HXE8,HXU,HX26,HX4,KTA,LD,LH,LHB3,LHQ4 LSJ4,LVL,LW2,LX,LXU,LX26,LX4,L1,PHM,PX,PXU,QAB3,QA26,QBT6,QD QE,QFE4,QH,QHE,QHP1,QHQ4,QH26,QKA4,QMC6,QMC8,QMD6,QME4,QMH,QNT QNT4,QNZ,QP,QPU,QT,QVL,QWA4,QXC6,QXE4,QXE6,QXE8,QXU,QXW,QX26 QX4,RD,RD4,RHQ4,RH26,RMB4,RSK,RX,RXE,RXE4,RXU,RX4,SD,SDS,SD16 SD4,SE,SH,SHM,SHQ4,SMC7,SMC9,SMX4,SM14,SWX4,SX,SXE,SXE4,SXS4 SXU,SX4,TXU,TX26,TX4,UXU,VEBM,VED,VED1,VED6,VMS4,VSD,VSX,VSX1 VSX3,VXE4,VXM,VXU,VXU1,VX4,WDA6,WKD6,WKT4,WKT6,WMB0,WME4 VSB1,VSG,VSW,VS3,VS4
18	17620-899-013	CAP COMP., FUEL FILLER	1 - - -	-----	-----
19	17631-ZH7-003	PACKING, FUEL FILLER CAP (39X58X3)	1 (1) - -	3063878	----- EN,ET,ETX,LAX,LTA,PH,PHU,PM,PM2,QA,QM,QXB,QZ,Q1,RAC,R1,SAC,SEE STA,SWX,SW2,SXB,S1,TH,THU,T1,UH,UX,VA,VH,VS,VS1,VXE,VXG,V1,W1 1 (1) - - 3063878 8542059 HH,KTA,LD,LH,LW2,LX,L1,PX,QD,QE,QH,QHE,QNT,QNZ,QXW,RD,RSK,RX RXE,SD,SDS,SE,SH,SX,SXE,VEBM,VED,VED1,VSD,VSX,VSX1,VXU 1 - - - ----- HXE,LDM,LD4,LHW,LSS4,NW,QBU2,QNT2,QXW2,SAD2,SDN,SHR4,SMB4,SWX2 VHQ4,VTD,VTD1,VXE6,VX26 1 - - - ----- 8542059 HHQ4,HH26,HXE2,HXE8,HXU,HX26,HX4,LHQ4,LSJ4,LXU,LX26,LX4,PHM PXU,QA26,QBT6,QFE4,QHP1,QHQ4,QH26,QKA4,QMC6,QMC8,QMD6,QME4,QMH QNT4,QP,QPU,QWA4,QXC6,QXE4,QXE6,QXE8,QXU,QX26,QX4,RD4,RHQ4 RH26,RMB4,RXE4,RXU,RX4,SD16,SD4,SHM,SHQ4,SMC7,SMC9,SMX4,SM14 SWX4,SXE4,SXS4,SXU,SX4,TXU,TX26,TX4,UXU,VED6,VMS4,VSX3,VXE4 VXM,VXU1,VX4,WDA6,WKD6,WKT4,WKT6,WMB0,WME4
			1 - - -	3063878	3394950 QT

Ref. No.	Part No.	Description	Reqd. QTY				Serial No.	Parts catalogue code
			(1)	(2)	(3)	(4)		
19)	17631-Z0T-812	PACKING, FUEL FILLER CAP (39X62X3)	1	(1)	-	-	8542060	----- BL,HH,HHQ4,HH26,HXE2,HXE8,HXU,HX26,HX4,KTA,LD,LH,LHB3,LHQ4 LSJ4,LVL,LW2,LX,LXU,LX26,LX4,L1,PHM,PX,PXU,QAB3,QA26,QBT6,QD QE,QFE4,QH,QHE,QHP1,QHQ4,QH26,QKA4,QMC6,QMC8,QMD6,QME4,QMH,QNT QNT4,QNZ,QP,QPU,QT,QVL,QWA4,QXC6,QXE4,QXE6,QXE8,QXU,QXW,QX26 QX4,RD,RD4,RHQ4,RH26,RMB4,RSK,RX,RXE,RXE4,RXU,RX4,SD,SDS,SD16 SD4,SE,SH,SHM,SHQ4,SMC7,SMC9,SMX4,SM14,SWX4,SX,SXE,SXE4,SXS4 SXU,SX4,TXU,TX26,TX4,UXU,VEBM,VED,VED1,VED6,VMS4,VSD,VSX,VSX1 VXS3,VXE4,VXM,VXU,VXU1,VX4,WDA6,WKD6,WKT4,WKT6,WMB0,WME4
20	17631-329-003	PACKING, FUEL FILLER CAP (39X58X3)	1	(1)	-	-	-----	----- H1,LDB1,LDB3,LVL,QAB1,QVL,QXB1,SDB1,SDB3,SDS2,SDS3,U1
			1	(1)	-	-	3063877	----- EN,ET,ETX,HH,KTA,LAX,LD,LH,LTA,LW2,LX,L1,PH,PHU,PM,PM2,PX,QA QD,QE,QH,QHE,QM,QNT,QNZ,QT,QXB,QXW,QZ,Q1,RAC,RD,RSK,RX,RXE,R1 SAC,SD,SDS,SE,SEE,SH,STA,SWX,SW2,SX,SXB,SXE,S1,TH,THU,T1,UH,UX VA,VEBM,VED,VED1,VH,VS,VSD,VSX,VSX1,VS1,VXE,VXU,V1,W1
			1	-	-	-	8542059	----- BL,LHB3,QAB3
			1	-	-	-	8542059	----- LVL,QVL
			1	-	-	-	3394951	----- 8542059 QT
			-	-	1	-	-----	----- WIH1
21	17631-899-000	PACKING, FUEL FILLER CAP	1	-	-	-	-----	----- VSB1,VSG,VSW,VS3,VS4
22	17670-899-000	FILTER COMP., FUEL	1	-	-	-	-----	----- VSB1,VSG,VSW,VS3,VS4
23	17672-ZE2-W00	FILTER, FUEL	1	-	-	-	2468780	----- EN,ET,ETX,LTA,LW2,QA,QNT,QT,QZ,RAC,SAC,SEE,STA,SWX,SW2,VED VED1,VS,VSX
	17672-ZE2-W01	1	(1)	-	-	2468780	----- BL,LDB3,LHB3,LHW,LSJ4,LSS4,LVL,NW,QAB1,QAB3,QA26,QIH1,QMH,QNT2 QNT4,QVL,SDB3,SDN,SDS2,SDS3,SHR4,SMX4,SM14,UIH,VED6,VSX3,VTD VTD1,WDA6,WIH1,WKD6,WKT4,WKT6
			1	-	-	-	2827377	----- EN,ET,ETX,KTA,LTA,LW2,QA,QNT,QT,QZ,RAC,SAC,SEE,STA,SWX,SW2,VED VED1,VS,VSX,VSX1,VS1
24	17672-880-000	FILTER, FUEL	1	(1)	-	-	2827377	----- 2827377 KTA,VSX1,VS1
			1	-	-	-	2468781	----- 2827376 EN,ET,ETX,LTA,LW2,QA,QNT,QT,QZ,RAC,SAC,SEE,STA,SWX,SW2,VED VED1,VS,VSX
			-	(1)	-	-	2468781	----- 2827376 2827376 KTA,VSX1,VS1
25	17673-893-000	HOLDER, FUEL FILTER	1	-	-	-	2468781	----- 2827376 EN,ET,ETX,LTA,LW2,QA,QNT,QT,QZ,RAC,SAC,SEE,STA,SWX,SW2,VED VED1,VS,VSX
			1	-	-	-	2468781	----- 2827376 2827376 EN,ET,ETX,LTA,LW2,QA,QNT,QT,QZ,RAC,SAC,SEE,STA,SWX,SW2,VED VED1,VS,VSX
			-	(1)	-	-	2468781	----- 2827376 2827376
26	17682-817-020	RUBBER, TANK CUSHION	4	-	-	-	-----	----- EN,ET,ETX
27	90503-898-000	WASHER, TANK CUSHION	4	-	-	-	-----	----- VSB1,VSG,VSW,VS3,VS4
28	90506-500-000	WASHER, AIR DUCT	2	-	-	-	-----	----- EN,ET,ETX
29	90851-898-000	RUBBER, TANK CUSHION	4	-	-	-	-----	----- VSB1,VSG,VSW,VS3,VS4
30	90854-ZB2-000	RUBBER, FUEL (9X15X10)	1	-	-	-	4795103	----- VSW,VS3,VS4
	90854-ZB3-000	RUBBER, FUEL (9X15X20)	1	-	-	-	-----	----- VPM4,VPM5,VPM7,VPR4,VPR7,VSG
			1	-	-	-	4795104	----- VSW,VS3,VS4



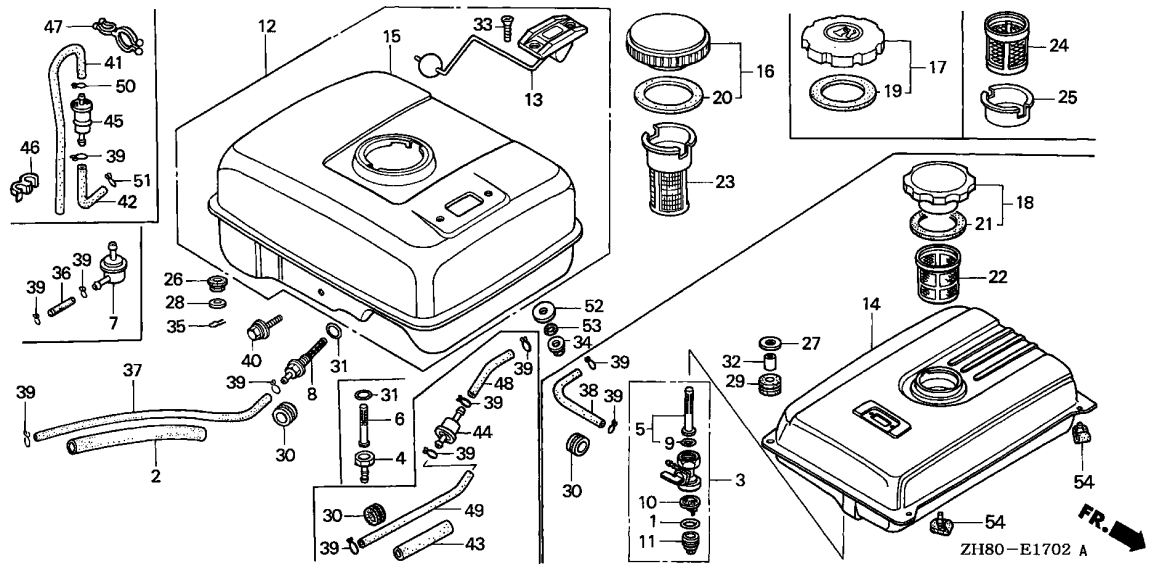

Ref. No.	Part No.	Description	Reqd. QTY				Serial No.	Parts catalogue code
			(1)	(2)	(3)	(4)		
			GX160K1					
31	91353-671-004	O-RING, 14MM(NOK)	1	-	-	-	-----	BL,HH,HHQ4,HH26,HXE,HXE2,HXE8,HXU,HX26,HX4,KTA,LAX,LD,LDB1,LDB3,LDM,LD4,LH,LHB3,LHQ4,LHW,LSJ4,LSS4,LT,LVL,LW2,LX,LXU,LX26,LX4,NW,PH,PHM,PHU,PM,PM2,PX,PXU,QA,QAB1,QAB3,QA26,QBT6,QBU2,QD,QE,QFE4,QH,QHE,QHP1,QHQ4,QH26,QKA4,QM,QMC6,QMC8,QMD6,QME4,QMH,QNT,QNT2,QNT4,QNZ,QP,QPU,QT,QVL,QWA4,QXB,QXB1,QXC6,QXE4,QXE6,QXE8,QXU,QXW,QXW2,QX26,QX4,QZ,RAC,RD,RD4,REX4,RHQ4,RH26,RMB4,RSK,RX,RXE,RXE4,RXU,RX4,SAC,SAD2,SD,SDB1,SDB3,SDN,SDS,SDS2,SDS3,SD16,SD4,SE,SEE,SH,SHM,SHQ4,SHR4,SMB4,SMC7,SMC9,SMX4,SM14,STA,SWG4,SWX,SWX2,SWX4,SW2,SX,SXB,SXE,SXE4,SXS4,SXU,SX4,TH,THU,TXU,TX26,TX4,UH,UX,UXU,VA,VEBM,VED,VED1,VED6,VGE4,VH,VHQ4,VMB3,VMS4,VPM5,VPM7,VPR7,VS,VS1,VSD,VXS,VSX1,VSX3,VS1,VS17,VTD,VTD1,VXE,VXE4,VXE6,VXG,VXM,VXU,VXU1,VX26,VX4,WDA6,WKD6,WKT4,WKT6,WMB0,WME4
			1	-	-	-	-----	3294336 EN,ET,ETX
32	91551-898-000	COLLAR, TANK CUSHION	-	(1)	1	-	-----	VSB1,VSG,VSW,VS3,VS4
33	93600-05010-0A	SCREW, FLAT, 5X10	4	-	-	-	-----	VSB1,VSG,VSW,VSX3,VS3,VS4,VXG
			2	-	-	-	-----	VSB1,VSG,VSW,VSX3,VS3,VS4,VXG
			-	(2)	-	-	-----	

2

Ref. No.	Part No.	Description	Reqd. QTY				Serial No.	Parts catalogue code
			(1)	GX160K1 (2)	(3)	(4)		
34	94050-06000	NUT, FLANGE, 6MM	1	-	-	-	VPM5	
			2	-	-	-	BL,HH,HHQ4,HH26,HXE,HXE2,HXE8,HXU,HX26,HX4,KTA,LAX,LD,LDB1 LDB3,LDM,LD4,LH,LHB3,LHQ4,LHW,LSJ4,LSS4,LTA,LVL,LW2,LX,LXU LX26,LX4,NW,PH,PHM,PHU,PM,PM2,PX,PXU,QA,QAB1,QAB3,QA26,QBT6 QBU2,QD,QE,QFE4,QH,QHE,QHP1,QHQ4,QH26,QKA4,QM,QMC6,QMC8,QMD6 QME4,QMH,QNT,QNT2,QNT4,QNZ,QP,QPU,QT,QVL,QWA4,QXB,QXB1,QXC6 QXE4,QXE6,QXE8,QXU,QXW,QXW2,QX26,QX4,QZ,RAC,RD,RD4,RHQ4,RH26 RMB4,RSK,RX,RXE,RXE4,RXU,RX4,SAC,SAD2,SD,SDB1,SDB3,SDN,SDS SDS2,SDS3,SD16,SD4,SE,SEE,SH,SHM,SHQ4,SHR4,SMB4,SMC7,SMC9,SMX4 SM14,STA,SWX,SWX2,SWX4,SW2,SX,SXB,SXE,SXE4,SXS4,SXU,SX4,TH,THU TXU,TX26,TX4,UH,UX,UXU,VA,VEBM,VED,VED1,VED6,VH,VHQ4,VMS4,VS VSD,VSX,VSX1,VSX3,VS1,VTD,VTD1,VXE,VXE4,VXE6,VXG,VXM,VXU,VXU1 VX26,VX4,WDA6,WKD6,WKT4,WKT6,WMB0,WME4	
			2	-	-	-	3294336 EN,ET,ETX	
35	94251-08000	PIN, LOCK, 8MM	2	(2)	2	-	EN,ET,ETX	
36	95001-45025-40	TUBE, FUEL, 4.5X25 (95001-45001-60M)	1	-	-	-	PHU,THU	
37	95001-45140-40	TUBE, FUEL, 4.5X140 (95001-45001-60M)	1	-	-	-	BL,HH,HHQ4,HH26,HXE,HXE2,HXE8,HXU,HX26,HX4,KTA,LAX,LD,LDB1 LDB3,LDM,LD4,LH,LHB3,LHQ4,LHW,LSJ4,LSS4,LTA,LVL,LW2,LX,LXU LX26,LX4,NW,PH,PHM,PHU,PM,PM2,PX,PXU,QA,QAB1,QAB3,QA26,QBT6 QBU2,QD,QE,QFE4,QH,QHE,QHP1,QHQ4,QH26,QKA4,QM,QMC6,QMC8,QMD6 QME4,QMH,QNT,QNT2,QNT4,QNZ,QP,QPU,QT,QVL,QWA4,QXB,QXB1,QXC6 QXE4,QXE6,QXE8,QXU,QXW,QXW2,QX26,QX4,QZ,RAC,RD,RD4,RHQ4,RH26 RMB4,RSK,RX,RXE,RXE4,RXU,RX4,SAC,SAD2,SD,SDB1,SDB3,SDN,SDS SDS2,SDS3,SD16,SD4,SE,SEE,SH,SHM,SHQ4,SHR4,SMB4,SMC7,SMC9,SMX4 SM14,STA,SWX,SWX2,SWX4,SW2,SX,SXB,SXE,SXE4,SXS4,SXU,SX4,TH,THU TXU,TX26,TX4,UH,UX,UXU,VA,VEBM,VED,VED1,VED6,VH,VHQ4,VMS4,VS VSD,VSX,VSX1,VSX3,VS1,VTD,VTD1,VXE,VXE4,VXE6,VXG,VXM,VXU,VXU1 VX26,VX4,WDA6,WKD6,WKT4,WKT6,WMB0,WME4	
			1	-	-	-	4764118 SWG4	
	95001-45350-40	TUBE, FUEL, 4.5X350 (95001-45001-60M)	1	(1)	1	-	ET,ETX	
	95001-45430-40	TUBE, FUEL, 4.5X430 (95001-45001-60M)	1	-	-	-	EN,VSD1,VS17	
	95001-45300-40	TUBE, FUEL, 4.5X300 (95001-45001-60M)	1	-	-	-	4764119 SWG4	
38	95001-45180-40	TUBE, FUEL, 4.5X180 (95001-45001-60M)	1	-	-	-	VSB1,VSG,VSU,VS3,VS4	



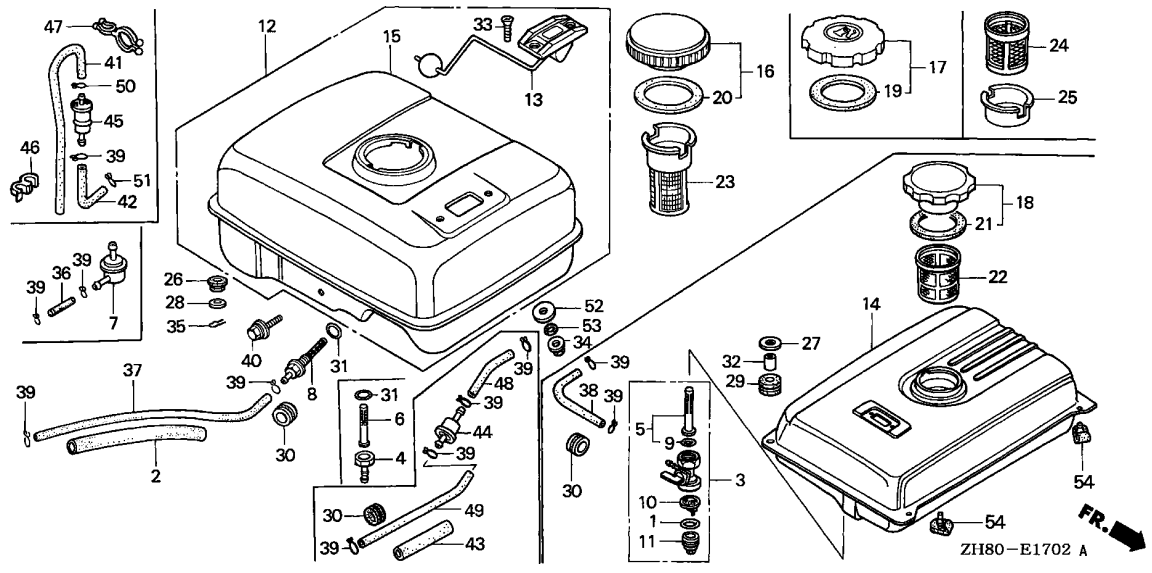

Ref. No.	Part No.	Description	Reqd. QTY				Serial No.	Parts catalogue code
			(1)	(2)	(3)	(4)		
39	95002-02080	CLIP, TUBE (B8)	1	-	-	-	ARC6	
			2	-	-	-	BL, EN, ET, ETX, HH, HHQ4, HH26, HXE, HXE2, HXE8, HXU, HX26, HX4, KTA, LAX, LD, LDB1, LDB3, LDM, LD4, LH, LHB3, LHQ4, LHW, LSJ4, LSS4, LTA, LVL, LW2, LX, LXU, LX26, LX4, NW, PH, PHM, PM, PM2, PX, PXU, QA, QAB1, QAB3, QA26, QBT6, QBU2, QD, QE, QFE4, QH, QHE, QHP1, QHQ4, QH26, QKA4, QM, QMC6, QMC8, QMD6, QME4, QMH, QNT, QNT2, QNT4, QNZ, QP, QPU, QT, QVL, QWA4, QXB, QXB1, QXC6, QXE4, QXE6, QXE8, QXU, QXW, QXW2, QX26, QX4, QZ, RAC, RD, RD4, RHQ4, RH26, RMB4, RSK, RX, RXE, RXE4, RXU, RX4, SAC, SAD2, SD, SDB1, SDB3, SDN, SDS, SDS2, SDS3, SD16, SD4, SE, SEE, SH, SHM, SHQ4, SHR4, SMB4, SMC7, SMC9, SMX4, SM14, STA, SWG4, SWX, SWX2, SWX4, SW2, SX, SXB, SXE, SXE4, SXS4, SXU, SX4, TH, TXU, TX26, TX4, UH, UX, UXU, VA, VEBM, VED, VED1, VED6, VH, VHQ4, VMS4, VS, VSB1, VSD, VSD1, VSG, VSW, VSX, VSX1, VSX3, VS1, VS17, VS3, VS4, VTD, VTD1, VXE, VXE4, VXE6, VXG, VXM, VXU, VXU1, VX26, VX4, WDA6, WKD6, WKT4, WKT6, WMBO, WME4, PHU, THU, VPM4, VPM5, VPM7, VPR4, VPR7	
			4	-	-	-		
			-	(2)	2	-		
40	95900-06025-00	BOLT, FLANGE, 6X25	1	-	1	-	HH, HXU, LD, LH, LTA, LW2, LX, LXU, PH, PM, PM2, PX, PXU, QA, QD, QE, QH, QHE, QM, QT, QXB1, QXE8, QXU, QZ, RAC, RD, RX, RXE, RXU, SAC, SD, SDS, SE, SEE, SH, SMB4, STA, SWX, SW2, SX, SXE, SXU, TH, TXU, UH, UIH, UX, UXU, VA, VEBM, VED, VED1, VH, VS, VSX, VXE	
			-	(1)	-	-		

Ref. No.	Part No.	Description	Reqd. QTY				Serial No.	Parts catalogue code
			(1)	(2)	(3)	(4)		
40)	95701-06025-00	BOLT, FLANGE, 6X25	1	-	1	-	-----	BL,HHQ4,HH26,HXE,HXE8,HX26,HX4,KTA,LAX,LDB1,LDB3,LDM,LD4,LHB3 LHQ4,LHW,LSJ4,LSS4,LX26,LX4,NW,PHM,PHU,QAB1,QAB3,QA26,QBT6 QBU2,QFE4,QHP1,QHQ4,QH26,QIH1,QKA4,QMC8,QME4,QMH,QNT,QNT2,QNT4 QNZ,QP,QPU,QWA4,QXB,QXC6,QXE4,QXE6,QXW,QXW2,QX26,QX4,RD4,RHQ4 RH26,RSK,RXE4,RX4,SAD2,SDB1,SDB3,SDN,SDS2,SDS3,SD16,SD4,SHM SHQ4,SHR4,SMC7,SMX4,SM14,SWX2,SWX4,SXB,SXE4,SXS4, SX4,THU,TX26 TX4,VED6,VHQ4,VIH1,VMS4,VSD,VSX1,VSX3,VS1,VTD,VTD1,VXE4,VXE6 VXG,VXM,VXU,VXU1,VX26,VX4,WIH1,WKD6,WKT4
	90004-ZH7-003	BOLT, FLANGE, 6X29	1	-	-	-	----- 3264336	EN,ET,ETX HXE2,LVL,QMC6,QMD6,QVL,RMB4,SMC9,WDA6,WKT6,WMB0,WME4
41	16198-ZG0-U00	TUBE A, AIR VENT	1	-	-	-	-----	ARC6
42	16199-KCR-000	TUBE	1	-	-	-	-----	ARC6
43	16854-ZH8-810	RUBBER, SUPPORTER (50MM)	1	-	-	-	-----	VPM4,VPM5,VPM7,VPR4,VPR7
44	16910-GB2-005	STRAINER COMP., FUEL	1	-	-	-	-----	VPM4,VPM5,VPM7,VPR4,VPR7
45	16910-ZG0-U01	STRAINER COMP., FUEL	1	-	-	-	----- 6330244	ARC6
	16910-ZG0-U02	1	-	-	-	----- 6330245	ARC6
46	91403-750-800	CLIP, DOUBLE	1	-	-	-	-----	ARC6
47	91473-PA1-003	CLIP, WATER HOSE	1	-	-	-	-----	ARC6
48	95001-45035-40	TUBE, FUEL, 4.5X35 (95001-45001-60M)	1	-	-	-	-----	VPM4,VPM5,VPM7,VPR4,VPR7
49	95001-45110-40	TUBE, FUEL, 4.5X110 (95001-45001-60M)	1	-	-	-	-----	VPM4,VPM5,VPM7,VPR4,VPR7
50	95002-02100	CLIP, TUBE (B10)	1	-	-	-	-----	ARC6
51	95002-50000	CLIP, TUBE (C9)	1	-	-	-	-----	ARC6
52	90404-680-000	WASHER, 6.5X25X1.5	2	-	-	-	-----	SMX4
53	91319-ME5-003	O-RING, 5.5X1.4	2	-	-	-	-----	SMX4
54	50319-ZB2-000	RUBBER, TANK MOUNTING	2	-	-	-	-----	VSG



E-17-3

FUEL TANK(4)

2-D 5

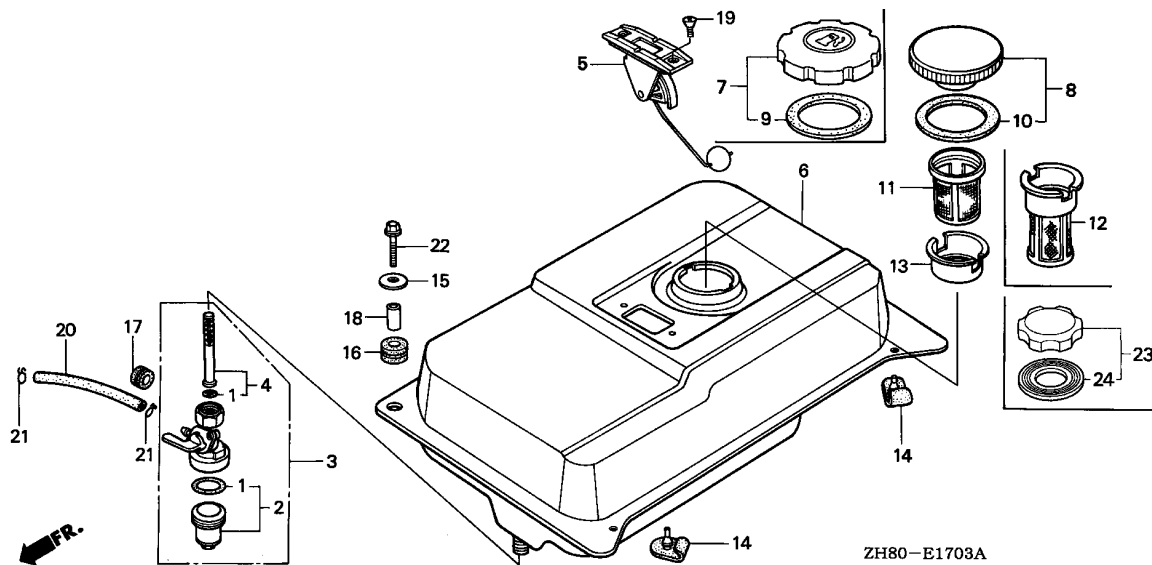

Ref. No.	L.O.N.	(Relative ref. Number) Description	F.R.T.
1	3101C4	PACKING SET, COCK	0.2
3	3101A3	COCK, FUEL	0.2
4	3101D4	SCREEN SET	0.2
5	6171A1	METER UNIT, FUEL	0.1
6	3101H7	TANK, FUEL	0.2
11		(12)	
	3101A6	FILTER, FUEL	0.1
20	3101K3	TUBE, FUEL COCK(A)	0.2

2

Ref. No.	Part No.	Description	Reqd. QTY				Serial No.	Parts catalogue code
			(1)	(2)	(3)	(4)		
1	16080-898-631	PACKING SET, COCK	1	-	-	-	VED2,VED3,VES,VMT,VTE2,VTX,VTX1	
2	16081-471-831	CUP, FUEL STRAINER	1	-	-	-	VED2,VES,VMT,VTE2,VTX,VTX1	
3	16950-898-632	COCK ASSY., FUEL	1	-	-	-	VED3,VTE2,VTX	
	16950-898-633	1	-	-	8018247	VED2,VMT,VTX1	
		1	-	-	-	VES	
4	16952-883-005	SCREEN SET	1	-	-	8018248	VED2,VMT,VTX1	
	16952-GG2-731	1	-	-	-	VTE2,VTX	
		1	-	-	8018247	VED2,VMT,VTX1	
		1	-	-	-	VES	
5	17505-ZB2-003	METER ASSY., FUEL	1	-	-	8018248	VED2,VMT,VTX1	
		1	-	-	-	VED2,VES,VMT,VTE2,VTX,VTX1	
6	17510-ZB2-000ZA	TANK COMP., FUEL	1	-	-	-	VES,VTX,VTX1	
	NH31MCKINLEY WHITE	1	-	-	-	VTE2	
	17510-ZB2-000ZB	*R8*.....BRIGHT RED	1	-	-	-	6880254	
		1	-	-	-	8478969	
		1	-	-	-	VED2	
	17510-ZB2-000ZG	*T68*.....TSURUMI BLUE	1	-	-	-	VED2	
	17510-ZB2-000ZH	*Y131*.....LIGHTNING YELLOW	1	-	-	-	VED2	
	17510-ZB2-000ZL	*NH1*.....BLACK	1	-	-	-	VED2	
	17510-ZB2-000ZM	*R280*.....POWER RED	1	-	-	8478970	VED2	
7	17620-ZH7-013	CAP COMP., FUEL FILLER	1	-	-	-	4705772	
		1	-	-	3063878	4705772	
		1	-	-	-	VTX,VTX1	
	17620-ZH7-023	CAP COMP., FUEL FILLER (BLACK)	1	-	-	4705773	VTE2	
		1	-	-	-	8542059	
		1	-	-	4705773	8542059	
		1	-	-	-	3063877	
8	17620-890-010	CAP COMP., FUEL FILLER	1	-	-	-	VED2	

Ref. No.	Part No.	Description	Reqd. QTY				Serial No.	Parts catalogue code
			GX160K1					
			(1)	(2)	(3)	(4)		
9	17631-ZH7-003	PACKING, FUEL FILLER CAP (39X58X3)	1	-	-	-	-----	VTE2,VTX,VTX1
			1	-	-	-	8542059	VMT
			1	-	-	-	3063878	8542059 VED2
10	17631-329-003	PACKING, FUEL FILLER CAP (39X58X3)	1	-	-	-	-----	3063877 VED2
11	17670-ZB2-000	FILTER COMP., FUEL	1	-	-	-	-----	2827376 VED2
12	17670-ZH7-A21	FILTER COMP., FUEL	1	-	-	-	-----	VES,VTE2,VTX,VTX1
			1	-	-	-	2827377	VED2
	17672-ZE2-W01	FILTER, FUEL	1	-	-	-	-----	VMT
13	17673-893-000	HOLDER, FUEL FILTER	1	-	-	-	-----	2827376 VED2
14	50319-ZB2-000	RUBBER, TANK MOUNTING	2	-	-	-	-----	VED2,VED3,VES,VMT,VTE2,VTX,VTX1
15	90506-500-000	WASHER, AIR DUCT	2	-	-	-	-----	VES,VTE2,VTX,VTX1
			4	-	-	-	-----	3477005 VED2
16	90852-898-000	RUBBER, CONTROL BOX	2	-	-	-	-----	VES,VMT,VTE2,VTX,VTX1
			4	-	-	-	-----	3477005 VED2
17	90854-ZB2-000	RUBBER, FUEL (9X15X10)	1	-	-	-	-----	4795103 VED2,VED3,VTE2
	90854-ZB3-000	RUBBER, FUEL (9X15X20)	1	-	-	-	-----	VES,VMT,VTX,VTX1
			1	-	-	-	4795104	VED2,VED3,VTE2
18	91552-898-000	COLLAR, CONTROL BOX	2	-	-	-	-----	VED2,VES,VMT,VTE2,VTX,VTX1
19	93600-05010-0A	SCREW, FLAT, 5X10	2	-	-	-	-----	VED2,VES,VMT,VTE2,VTX,VTX1
20	95001-45095-40	TUBE, FUEL, 4.5X95 (95001-45001-60M)	1	-	-	-	-----	VED3
			1	-	-	-	-----	3477005 VED2
	95001-45260-40	TUBE, FUEL, 4.5X260 (95001-45001-60M)	1	-	-	-	3477006	4263875 VED2
	95001-45150-40	TUBE, FUEL, 4.5X150 (95001-45001-60M)	1	-	-	-	-----	VES,VTE2,VTX,VTX1
			1	-	-	-	4263876	VED2
	95001-45250-40	TUBE, FUEL, 4.5X250 (95001-45001-60M)	1	-	-	-	-----	VMT
21	95002-02080	CLIP, TUBE (B8)	2	-	-	-	-----	VED2,VED3,VES,VMT,VTE2,VTX,VTX1
22	95701-06020-00	BOLT, FLANGE, 6X20	2	-	-	-	-----	VED2,VES,VTE2
23	17620-Z0T-814	CAP COMP., FUEL FILLER (CHROME PLATED)	1	-	-	-	-----	VES
			1	-	-	-	8542060	VED2,VMT
24	17631-Z0T-812	PACKING, FUEL FILLER CAP (39X62X3)	1	-	-	-	-----	VES
			1	-	-	-	8542060	VED2,VMT

E-17-4

FUEL TANK(5)

2-D 7

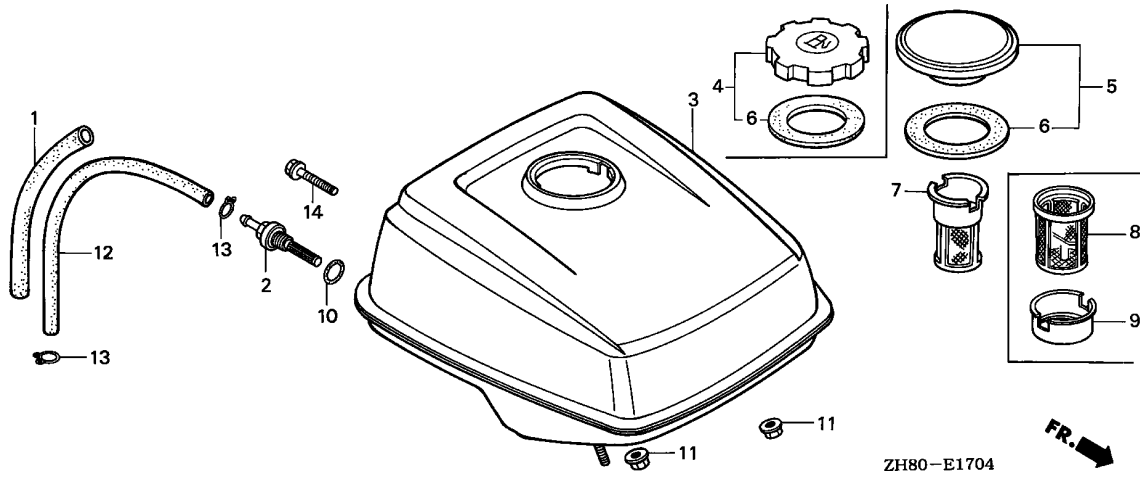

Ref. No.	L.O.N.	(Relative ref. Number) Description	F.R.T.
2	3101H6	STRAINER, JOINT FUEL	0.2
3	3101H7	TANK, FUEL (8)	0.2
7	3101A6	FILTER, FUEL	0.1
12	3101K5	TUBE, FUEL TANK(A)	0.2

2

Ref. No.	Part No.	Description	Reqd. QTY				Serial No.	Parts catalogue code
			(1)	(2)	(3)	(4)		
1	16854-ZH8-000	RUBBER, SUPPORTER (107MM) ...	1	-	-	-	-----	LJS
2	16955-ZE1-000	JOINT, FUEL TANK	1	-	-	-	-----	LJS
3	17510-734-701ZA	TANK COMP., FUEL *NH31*.....MCKINLEY WHITE	1	-	-	-	-----	LJS
4	17620-ZH7-013	CAP COMP., FUEL FILLER	1	-	-	3063878	4705772	LJS
	17620-ZH7-023	CAP COMP., FUEL FILLER (BLACK)	1	-	-	4705773	8542059	LJS
	17620-ZOT-814	CAP COMP., FUEL FILLER (CHROME PLATED)	1	-	-	8542060	-----	LJS
5	17620-ZE2-W00	CAP COMP., FUEL FILLER (CHROME PLATED)	1	-	-	-----	3063877	LJS
6	17631-329-003	PACKING, FUEL FILLER CAP (39X58X3)	1	-	-	-----	3063877	LJS
	17631-ZH7-003	1	-	-	3063878	8542059	LJS
	17631-ZOT-812	PACKING, FUEL FILLER CAP (39X62X3)	1	-	-	8542060	-----	LJS
7	17670-ZH7-A81	FILTER COMP., FUEL	1	-	-	2827516	-----	LJS
8	17672-887-791	FILTER, FUEL	1	-	-	-----	2827515	LJS
9	17673-893-000	HOLDER, FUEL FILTER	1	-	-	-----	2827515	LJS
10	91353-671-004	O-RING, 14MM(NOK)	1	-	-	-----	-----	LJS
11	94050-06000	NUT, FLANGE, 6MM	2	-	-	-----	-----	LJS
12	95001-45140-40	TUBE, FUEL, 4.5X140 (95001-45001-60M)	1	-	-	-----	-----	LJS
13	95002-02080	CLIP, TUBE (B8)	2	-	-	-----	-----	LJS
14	95900-06025-00	BOLT, FLANGE, 6X25	1	-	-	-----	-----	LJS

E-17-5

FUEL TANK(6)

2-D 8

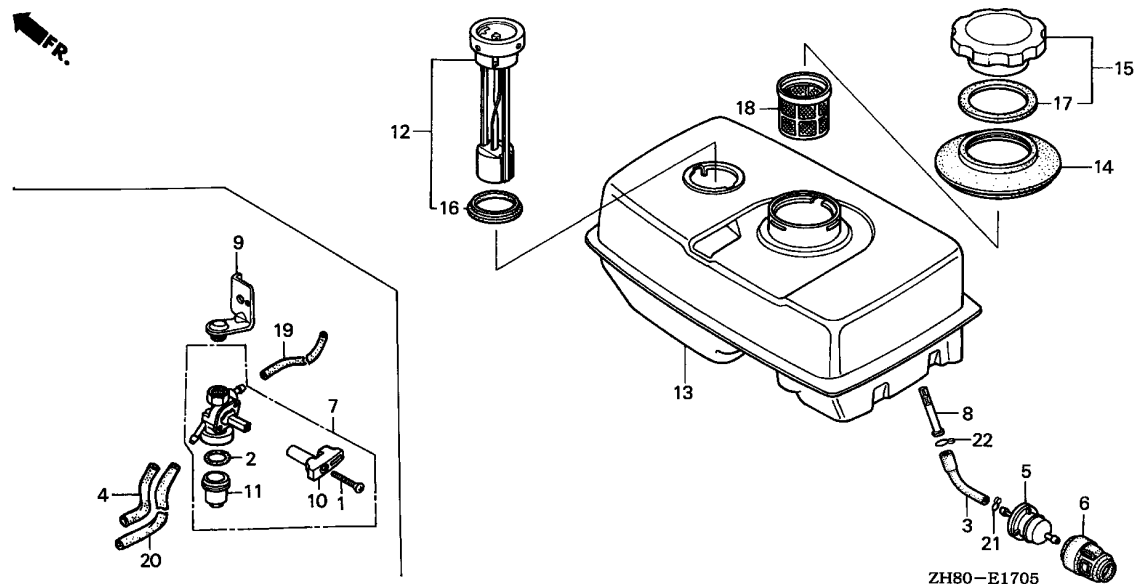

Ref. No.	L.O.N.	(Relative ref. Number) Description	F.R.T.
3	3101K5	TUBE, FUEL TANK(A)	0.2
5	3101H8	STRAINER, FUEL	0.1
7	3101A3	COCK, FUEL	0.2
8	3101D5	SCREEN, FUEL STRAINER	0.2
10	3101E6	LEVER, FUEL COCK	0.1
12		(16)	
	6171A1	METER UNIT, FUEL	0.1
13	3101H7	TANK, FUEL	0.2
18	3101A6	FILTER, FUEL	0.1
20	3101F2	TUBE, FUEL COCK	0.2

Ref. No.	Part No.	Description	Reqd. QTY				Serial No.	Parts catalogue code
			(1)	(2)	(3)	(4)		
			GX160K1					
1	16080-191-005	SCREW, OVAL, 4X32	1	-	-	-	NJC1	
2	16173-001-004	PACKING, FUEL STRAINER CUP ..	1	-	-	-	NJC1	
3	16852-ZB6-000	TUBE, FUEL TANK	1	-	-	-	NJC1	
4	16857-ZB6-000	RUBBER, SUPPORTER	1	-	-	-	NJC1	
5	16910-GB2-005	STRAINER COMP., FUEL	1	-	-	-	NJC1	
6	16915-GB2-000	SUSPENSION, STRAINER	1	-	-	-	NJC1	
7	16950-ZA0-013	COCK ASSY., FUEL	1	-	-	-	NJC1	
8	16952-ZB6-000	BUSH, FUEL PURGE	1	-	-	-	NJC1	
9	16956-ZA0-010	STAY COMP., FUEL COCK	1	-	-	-	NJC1	
10	16963-191-005	LEVER, FUEL COCK	1	-	-	-	NJC1	
11	16967-MA2-771	CUP, FUEL STRAINER	1	-	-	-	NJC1	
12	17505-898-023	METER COMP., FUEL	1	-	-	-	NJC1	
13	17510-ZB6-010	TANK COMP., FUEL	1	-	-	-	NJC1	
14	17520-ZA0-800	SEAL, FUEL FILLER NECK	1	-	-	-	NJC1	
15	17620-899-013	CAP COMP., FUEL FILLER	1	-	-	-	NJC1	
16	17624-187-020	PACKING C, FUEL METER	1	-	-	-	NJC1	
17	17631-899-000	PACKING, FUEL FILLER CAP	1	-	-	-	NJC1	
18	17670-ZB6-000	FILTER COMP., FUEL	1	-	-	-	NJC1	
19	95001-45080-40	TUBE, FUEL, 4.5X80						
		(95001-45001-60M)	1	-	-	-	NJC1	
20	95001-45300-40	TUBE, FUEL, 4.5X300						
		(95001-45001-60M)	1	-	-	-	NJC1	
21	95002-02080	CLIP, TUBE (B8)	1	-	-	7101870	NJC1	
22	95002-02100	CLIP, TUBE (B10)	1	-	-		NJC1	

2

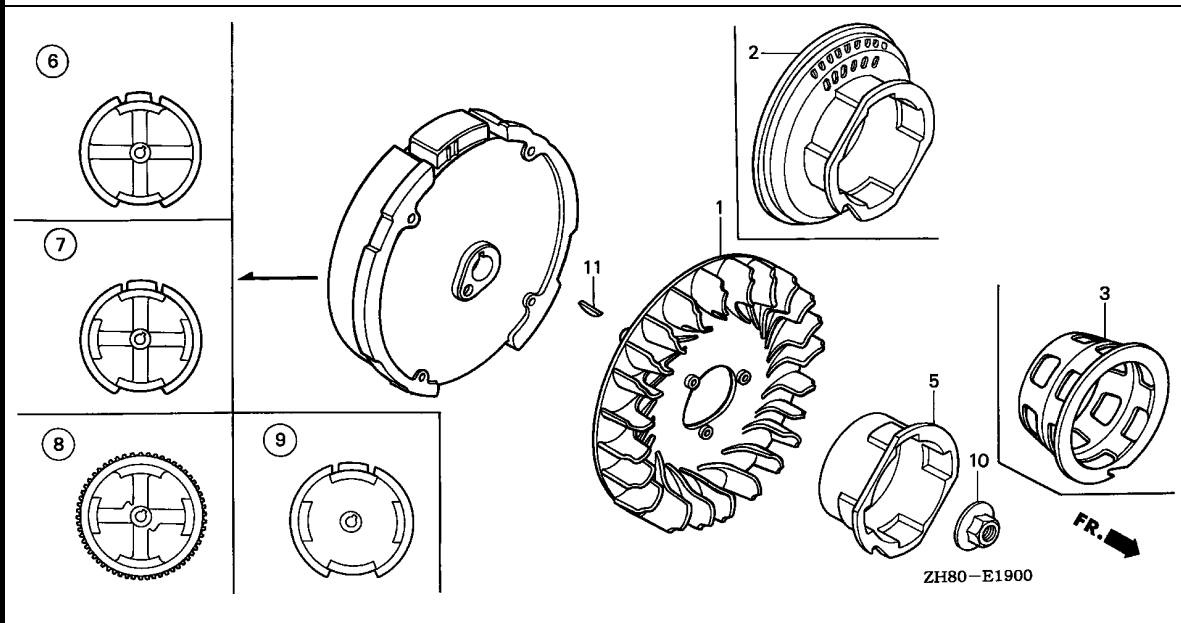

Ref. No.	L.O.N.	(Relative ref. Number) Description	F.R.T.
1	1141G7	FAN, ENGINE COOLING	0.2
5		(2,3)	
	1121A9	PULLEY, RECOIL STARTER	0.2
6	2161B5	FLYWHEEL	0.3



Ref. No.	Part No.	Description	Reqd. QTY				Serial No.	Parts catalogue code
			(1)	(2)	(3)	(4)		
1	19511-ZE1-000	FAN, COOLING	1	-	-	-	-----	AR, ARC6, BL, DS, DSP, EMA, EMA2, EN, ET, ETX, HG1, HG12, HH, HHQ4, HH26, HX, HXE, HXE2, HXE8, HXQ, HXU, HX2, HX26, HX4, KR, KTA, LAX, LAX2, LD, LDB1, LDB3, LDM, LD4, LH, LHB3, LHQ4, LHW, LJ, LJ2, LJ3, LJC7, LJD, LJG, LJS, LMT, LSJ, LSJ4, LSS, LSS1, LSS4, LTA, LTK, LVL, LW2, LX, LXU, LX2, LX26, LX4, NJ, NJC1, NJG, NSJ, NW, PH, PHM, PHU, PM, PM2, PX, PXU, PX2, QA, QAB1, QAB3, QAX, QAX2, QA2, QA26, QBC2, QBT2, QBT6, QBU2, QCB2, QCL, QD, QE, QFE4, QGR2, QGR9, QH, QHE, QHP1, QHQ4, QH26, QI2, QKA4, QM, QMC6, QMC8, QMD6, QME4, QMH, QMX2, QM2, QNT, QNT2, QNT4, QNZ, QP, QPU, QSC2, QSC9, QS2, QT, QVL, QWA4, QWM2, QWX2, QWX3, QX, QXB, QXB1, QXC, QXC6, QXC9, QXE, QXE2, QXE4, QXE6, QXE8, QXF, QXF2, QXM1, QXQ, QXS, QXS2, QXU, QXW, QXW2, QX2, QX22, QX26, QX4, QX7, QZ, RAC, RD, RD4, REX4, RFR, RFR2, RH, RHA, RHA2, RHQ4, RH2, RH26, RMB4, RMD, RMG2, RNG, RSK, RSS1, RTB2, RX, RXE, RXE2, RXE4, RXU, RX4, SAC, SAD2, SCJ, SD, SDB1, SDB3, SDN, SDS, SDS2, SDS3, SD16, SD4, SE, SEE, SH, SHM, SHQ4, SHRY, SHR4, SJ, SJC, SJC1, SJC5, SJG, SKM, SMB4, SMC7, SMC9, SMJ, SMJ1, SMW2, SMX4, SM11, SM12, SM14, SNX, SNX1, SSK1, SSK2, SSS2, ST, STA, STM, STP, STQ, SWG4, SWX, SWX2, SWX4, SW2, SX, SXB, SXE, SXE4, SXS4, SXU, SX4, SX7, S1CY, TCS2, TH, THU, TX, TXC9, TXU, TX2, TX26, TX4, UH, UX, UXU, VA, VA2, VEBM, VEB2, VED, VED1, VED2, VED3, VED5, VED6, VED7, VEN2, VES, VGE4, VH, VHA7, VHH4, VHQ4, VMB3, VMS4, VMS7, VMT, VPM4, VPM5, VPM7, VPR4, VPR7, VS, VSB1, VSD, VSD1, VSD7, VSG, VSW, VSX, VSX1, VSX3, VS1, VS17, VS3, VS4, VTD, VTD1, VTE2, VTU1, VTX, VTX1, VVA, VVA2, VW12, VX, VXD, VXD1, VXE, VXE4, VXE6, VXE7, VXG, VXM, VXU, VXU1, VXW, VXW1, VXW2, VX2, VX26, VX4, WDA6, WJP, WKD6, WKT2, WKT4, WKT6, WMBO, WME2, WME4, WMT
2	28450-ZH8-811	PULLEY COMP., STARTER	1	-	1	1	-----	LHW, LSJ, LSS, LSS4, QA, QAB1, QA2, QA26, QBU2, QE, QFE4, QMC8, QMD6, QWA4, RAC, SAC, SAD2, SE, SG24, SHRY, SHR4, SMC7, SMC9, VEBM, VEB2, VG24, VMB3, 6649704, QAB3

Ref. No.	Part No.	Description	Reqd. QTY				Serial No.	Parts catalogue code
			(1)	(2)	(3)	(4)		
3	28451-ZE1-003	PULLEY, STARTER	1	-	-	-	LJS,LMT,LVL,QVL,VSB1,VSG,VSW,VS3,VS4	
			1	-	-	-	QT	
5	28451-ZH8-003	PULLEY, STARTER	1	-	-	-	6219319	
							AR,ARC6,BL,DS,DSP,EMA,EMA2,EN,ET,ETX,HG1,HG12,HH,HHQ4,HH26,HX,HXE,HXE2,HXE8,HXQ,HXU,HX2,HX26,HX4,KR,KTA,LAX,LAX2,LD,LDB1,LDB3,LDM,LD4,LH,LHB3,LHQ4,LJ,LJC7,LJD,LJG,LSJ4,LSS1,LTA,LTK,LW2,LX,LXU,LX2,LX26,LX4,NJ,NJC1,NJG,NSJ,NW,PH,PHM,PHU,PM,PM2,PX,PXU,PX2,QAX,QAX2,QBC2,QBT2,QBT6,QCB2,QCL,QD,QGR2,QGR9,QH,QHE,QHP1,QHQ4,QH26,QI2,QKA4,QM,QMC6,QME4,QMH,QMX2,QMZ2,QNT,QNT2,QNT4,QNZ,QP,QPU,QSC2,QSC9,QS2,QWM2,QWX2,QWX3,QX,QXB,QXB1,QXC,QXC6,QXC9,QXE,QXE2,QXE4,QXE6,QXE8,QXF,QXF2,QXM1,QXQ,QXS,QXS2,QXU,QXW,QXW2,QX2,QX22,QX26,QX4,QX7,QZ,RD,RD4,REX4,RFR,RFR2,RH,RHA,RHA2,RHQ4,RH2,RH26,RMB4,RMD,RMG2,RNG,RSK,RSS1,RTB2,RX,RXE,RXE2,RXE4,RXU,RX4,SCJ,SD,SDB1,SDB3,SDN,SDS,SDS2,SDS3,SD16,SD4,SEE,SH,SHM,SHQ4,SJ,SJC,SJC1,SJC5,SJG,SKM,SMB4,SMJ,SMJ1,SMW2,SMX4,SM11,SM12,SM14,SNX,SNX1,SSK1,SSK2,SSX2,ST,STA,STM,STP,STQ,SWG4,SWX,SWX2,SWX4,SW2, SX, SXB, SXE, SXE4, SXS4, SXU, SX4, SX7, S1CY, TCS2, TH, THU, TX, TXC9, TXU, TX2, TX26, TX4, UH, UX, UXU, VA, VA2, VED, VED1, VED2, VED3, VED5, VED6, VED7, VEN2, VES, VGE4, VH, VHA7, VHH4, VHQ4, VMS4, VMS7, VMT, VPM4, VPM5, VPM7, VPR4, VPR7, VS, VSD, VSD1, VSD7, VSX, VSX1, VSX3, VS1, VS17, VTD, VTD1, VTE2, VTU1, VTX, VTX1, VWA, VWA2, VW12, VX, VXD, VXD1, VXE, VXE4, VXE6, VXE7, VXG, VXM, VXU, VXU1, VXW, VXW1, VXW2, VX2, VX26, VX4, WDA6, WJP, WKD6, WKT2, WKT4, WKT6, WMB0, WME2, WME4, WMT, QAB3	
			1	-	-	-	6649705	
			1	-	-	-	6219318	
			-	(1)	1	1	QT	
6	31100-ZE1-000	FLYWHEEL COMP.	-	(1)	-	-	H1,U1	
	31100-ZE7-010	FLYWHEEL COMP. (STD.)	1	-	-	-	QX7, SX7, VHA7, VMS7, VPM7, VPR7, VSD7, VS17	
	31100-ZE1-010	FLYWHEEL COMP.	1	(1)	-	1	AR,ARC6,BL,DS,DSP,EN,ET,ETX,HG1,HG12,HH,HHQ4,HH26,HX,HXQ,HXU,HX2,HX26,HX4,KR,KTA,LD,LDB1,LDB3,LDM,LD4,LH,LHB3,LHQ4,LJ,LJC7,LJD,LJG,LJS,LMT,LSJ,LSJ4,LSS4,LTA,LTK,LVL,LX,LXU,LX2,LX26,LX4,L1,NJ,NJC1,NJG,NW,PH,PHM,PHU,PM,PM2,PX,PXU,PX2,QA,QAB1,QAB3,QA2,QA26,QBC2,QBT2,QBT6,QBU2,QCB2,QCL,QD,QE,QFE4,QGR2,QH,QHP1,QHQ4,QH26,QI2,QM,QMC8,QME4,QMH,QMX2,QMZ2,QNT,QNT2,QNT4,QPU,QXS2,QT,QVL,QWA4,QWM2,QWX2,QWX3,QX,QXB,QXB1,QXC,QXC6,QXC9,QXF,QXF2,QXM1,QXQ,QXU,QX2,QX22,QX26,QX4,QZ,Q1,RAC,RD,RD4,RFR,RFR2,RH,RHQ4,RH2,RH26,RMB4,RMD,RNG,RSS1,RTB2,RX,RXU,RX4,R1,SAC,SAD2,SCJ,SD,SDB1,SDB3,SDN,SDS2,SDS3,SD16,SD4,SE,SG24,SH,SHM,SHQ4,SHRY,SHR4,SJ,SJC,SJC1,SJC5,SJG,SMB4,SMC7,SMJ,SMJ1,SMW2,SMX4,SM11,SM12,SM14,SNX,SSK1,SSK2,SSX2,STA,STP,STQ,SWX,SWX2,SWX4,SX,SXB,SXS4,SXU,SX4,S1,S1CY,TCS2,TH,THU,TX,TC9,TXU,TX2,TX26,TX4,T1,UH,UX,UXU,VA,VA2,VEBM,VEB2,VED,VED1,VED2,VED3,VED5,VED6,VED7,VEN2,VGE4,VG24,VH,VHH4,VHQ4,VMB3,VMS4,VMT,VPM4,VPM5,VPR4,VS,VSB1,VSD,VSDP,VSD1,VSG,VSX,VSX1,VSX3,VS1,VS3,VS4,VTD,VTD1,VTE2,VTU1,VTX,VTX1,VWA,VWA2,VW12,VX,VXG,VXM,VXP,VXU,VXU1,VXW,VXW1,VXW2,VX2,VX26,VX4,V1,WDA6,WJP,WKD6,WKT2,WKT4,WKT6,WMB0,WME2,WME4,WMT,W1	
			-	-	1	-	H1,T1,U1,V1,W1	
7	31100-ZE1-810	FLYWHEEL COMP. (LAMP)	-	(1)	-	-	H1,T1,U1,V1,W1	
	31100-ZE1-811	1	(1)	-	1	EMA,EMA2,LHW,LSS,LW2,L1,NSJ,QMC6,QMD6,QP,QXS,QXS2,Q1,RHA,RHA2,RMG2,RSK,R1,SDS,SMC9,STM,SW2,SXP1,S1,VES,VXD,VXD1	
8	31100-ZE1-820	FLYWHEEL COMP. (STARTER MOTOR)	-	(1)	-	-	H1,T1,U1,W1	
	31110-ZLO-821	FLYWHEEL COMP. (START)	1	-	-	-	VXE7	
	31100-ZE1-821	FLYWHEEL COMP. (STARTER MOTOR)	1	(1)	-	-	HXE,HXE2,HXE8,LSS1,L1,QHE,QKA4,QXE,QXE2,QXE4,QXE6,QXE8,QXW,QXW2,Q1,RXE,RXE2,RXE4,R1,SEE,SKM,SNX1,ST,STM,SWG4,SXE,SXE4,S1,VSW,VXE,VXE4,VXE6,V1	



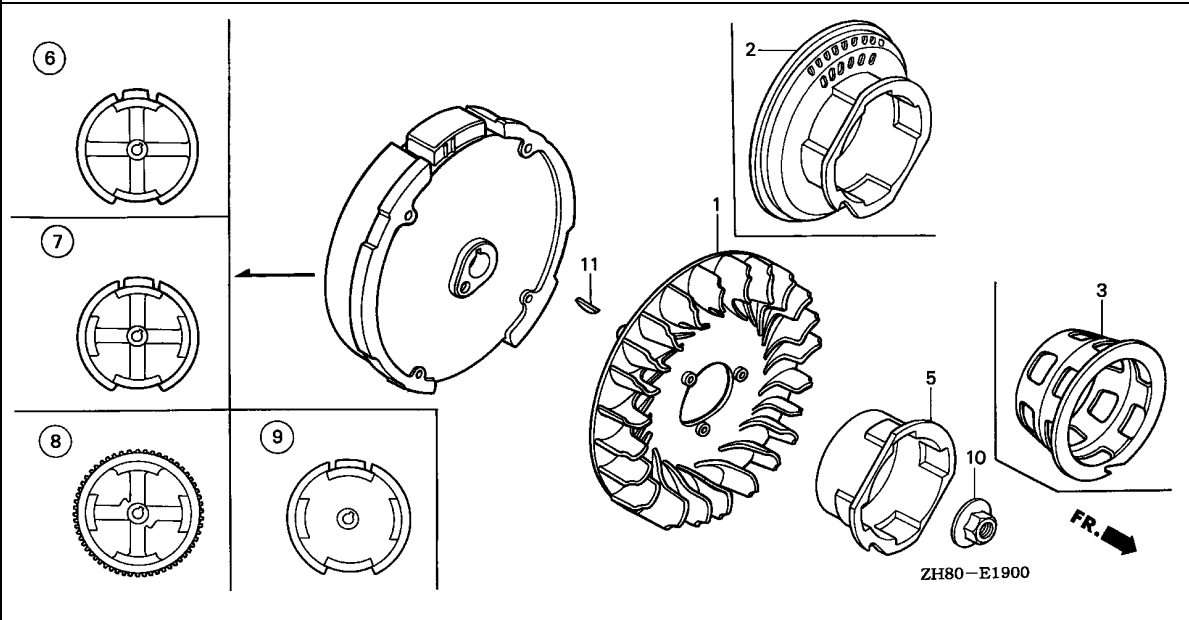

Ref. No.	Part No.	Description	Reqd. QTY				Serial No.	Parts catalogue code
			(1)	(2)	(3)	(4)		
9	31100-ZH8-S42	FLYWHEEL COMP. (SELF STARTER-7A)	1	-	-	-	----- QNZ,QSC2,REX4	
	31100-ZH8-W03	FLYWHEEL COMP. (4P-3MAGNET)	1	-	-	-	----- LAX,LAX2,QAX,QAX2,QGR9,QSC9	
10	90201-878-003	NUT, SPECIAL, 14MM	1	(1)	-	-		
11	13331-357-000	KEY, SPECIAL WOODRUFF, 25X18	1	1	1	1		

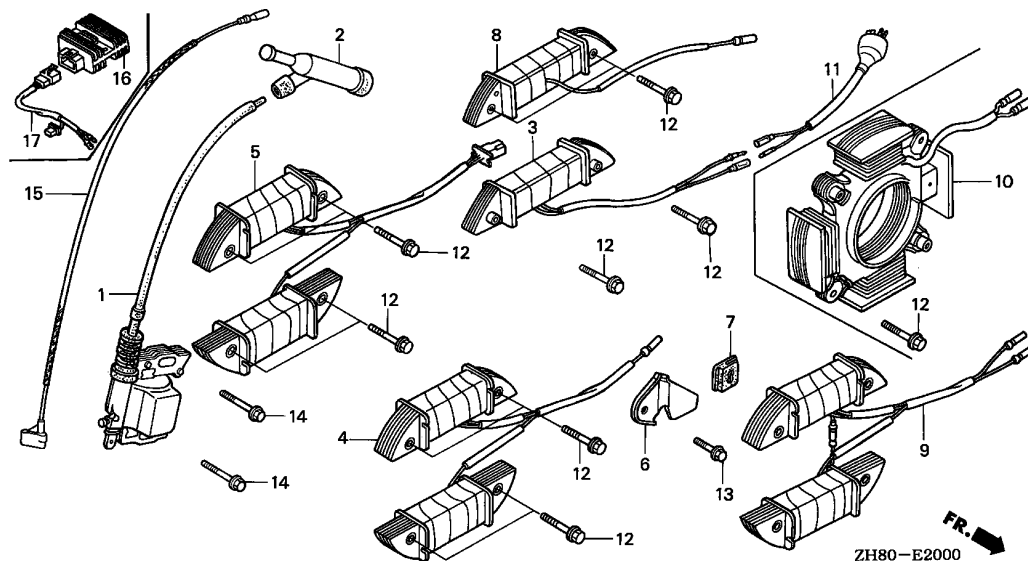

Ref. No.	L.O.N.	(Relative ref. Number) Description	F.R.T.
1	6141A5	COIL, IGNITION	0.2
2	6141B8	TERMINAL, HIGH TENSION	0.1
3		(4)	
	6141A6	COIL, LAMP	0.3
5	6141A7	COIL, LAMP AND CHARGE	0.3
8		(9,10)	
	6131C3	COIL, CHARGE	0.3
11	6141C6	CABLE, DOUBLE CONNECTOR(A) ...	0.2
15	6111B3	CORD, STOP SWITCH	0.3
16	6131B7	RECTIFIER, REGULATOR	0.2
17	6111E6	HARNESS, REGULATOR RECTIFIER .	0.2

ZH80-E2000

Ref. No.	Part No.	Description	Reqd. QTY				Serial No.	Parts catalogue code	
			(1)	(2)	(3)	(4)			
1	30500-ZE1-033	COIL ASSY., IGNITION	1	(1)	1	1	AR,ARC6,DS,DSP,EMA,EMA2,EN,ET,ETX,HG1,HG12,HH,HX,HXE,HXQ,HX2,H1,KR,KTA,LAX,LAX2,LD,LDB1,LDB3,LDM,LD4,LH,LHB3,LHW,LJ,LJC7,LJD,LJG,LJS,LMT,LSJ,LSJ4,LSS,LSS1,LSS4,LTA,LTk,LW2,LX,LX2,NJ,NJC1,NJG,NSJ,NW,PH,PHU,PM,PM2,PX,PX2,QA,QAB1,QAB3,QAX,QAX2,QA2,QBC2,QBT2,QBU2,QCB2,QCL,QD,QE,QGR2,QGR9,QH,QHE,QHP1,QI2,QKA4,QM,QME4,QMH,QMX2,QMZ2,QNT,QNT2,QNZ,QP,QPU,QSC2,QT,QWM2,QWX2,QWX3,QX,QXB,QXB1,QXC,QXC9,QXE,QXE2,QXF,QXF2,QXQ,QXS,QXS2,QXW,QXW2,QX2,QX22,QZ,Q1,RAC,RD,REX4,RFR,RFR2,RH,RHA,RHA2,RH2,RMD,RMG2,RNG,RSK,RSS1,RTB2,RX,RXE,RXE2,R1,SAC,SAD2,SCJ,SD,SDB1,SDB3,SDN,SDS,SDS2,SDS3,SE,SEE,SG24,SH,SHRY,SJ,SJC,SJC1,SJC5,SJG,SKM,SMB4,SMJ,SMJ1,SMW2,SMX4,SM11,SM12,SM14,SNX,SNX1,SSK1,SSK2,SSX2,ST,STA,STM,STP,STQ,SWG4,SWX,SWX2,SWX4,SW2,SX,AXB,SXE,SXS4,S1,S1CY,TCS2,TH,THU,TX,TXC9,TX2,T1,UH,UIH,UX,U1,VA,VA2,VEBM,VEB2,VED,VED1,VED2,VED3,VED5,VED6,VED7,VEN2,VGE4,VG24,VH,VHH4,VHQ4,VMS4,VMT,VPM4,VPR4,VS,VSD,VSDP,VSD1,VSG,VSW,VSX,VSX1,VSX3,VS1,VS3,VS4,VTD1,VTE2,VTX,VWA,VWA2,VW12,VX,VXD,VXD1,VXE,VXE6,VXG,VXP,VXU,VXW,VXW1,VXW2,VX2,VX26,V1,WDA6,WJP,WKD6,WKT2,WKT4,WME2,WME4,WMT,W1		
			1	(1)	-	-	8074561	BL,HHQ4,HH26,HXE8,HXU,HX26,HX4,LHQ4,LVL,LXU,LX26,LX4,L1,PHM,PXU,QA26,QBT6,QFE4,QH4,QH26,QMC6,QMC8,QMD6,QNT4,QSC9,QVL,QWA4,QXC6,QXE4,QXE6,QXE8,QXM1,QXU,QX26,QX4,RD4,RHQ4,RH26,RMB4,RXE4,RXU,RX4,SD16,SD4,SHM,SHQ4,SHR4,SMC7,SMC9,SXE4,SXU,SX4,TXU,TX26,TX4,UXU,VMB3,VPM7,VPR7,VS1,VS17,VTD,VTU1,VTX1,VXE4,VXM,VXU1,VX4,WKT6,WMO	
			-	-	-	1	2000254	SXP1	



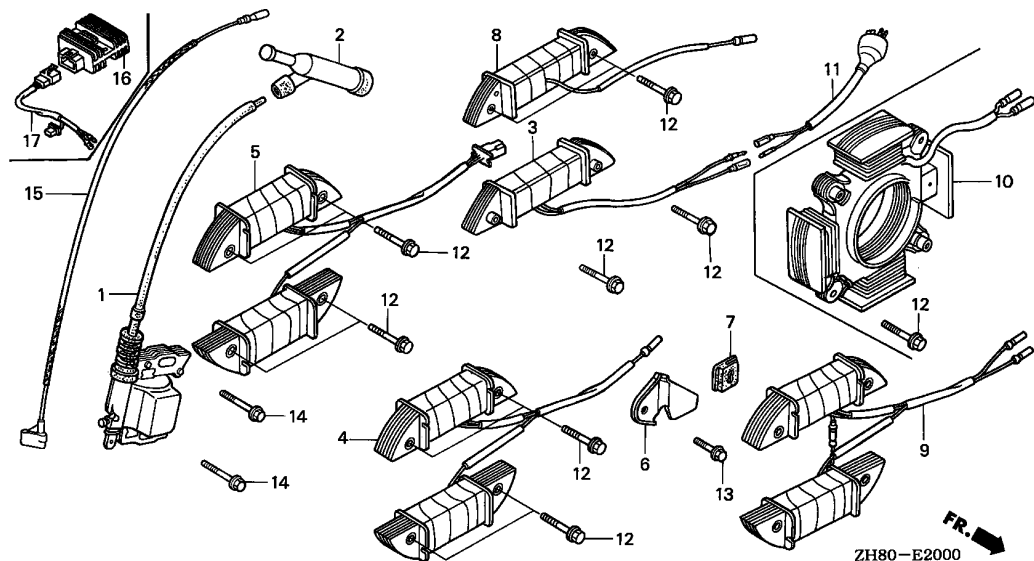

ZH80-E2000

Ref. No.	Part No.	Description	Reqd. QTY				Serial No.	Parts catalogue code
			(1)	(2)	(3)	(4)		
(1)	30500-ZE1-043	COIL ASSY., IGNITION	1	(1)	-	-	8074562	BL, HHQ4, HH26, HXE8, HXU, HX26, HX4, LHQ4, LVL, LXU, LX26, LX4, L1, PHM, PXU, QA26, QBT6, QFE4, QHQ4, QH26, QMC6, QMC8, QMD6, QNT4, QSC9, QVL, QWA4, QXC6, QXE4, QXE6, QXE8, QXM1, QXU, QX26, QX4, RD4, RHQ4, RH26, RMB4, RXE4, RXU, RX4, SD16, SD4, SHM, SHQ4, SHR4, SMC7, SMC9, SXE4, SXU, SX4, TXU, TX26, TX4, UXU, VMB3, VPM7, VPR7, VSB1, VS17, VTD, VTU1, VTX1, VXE4, VXM, VXU1, VX4, WKT6, WMBO
			1	-	1	-	2000255	HXE2, QIH1, QS2, QX7, SX7, VES, VHA7, VIH1, VMS7, VPM5, VSD7, VXE7, WIH1, SXP1
2	30600-ZE1-013	TERMINAL ASSY., HIGH TENSION (NICHIWA Y-EZ)	1	-	1	-		EN, ET, ETX, LJD, LJS, LMT, LSS1, LTA, LTK, LW2, PM, QIH1, QM, QT, RMD, SDN, SDS3, SKM, SMJ, SM11, ST, STA, STM, SW2, UIH, VS1, WIH1
			1	-	-	-	3923402	QAB1
			1	-	-	-	4224869	VSX, VSX1, VS3, VS4
			1	-	-	-	3923401	LD4, QMC6, RD4, SDS, SD4, WMBO
			1	-	-	-	5249928	AR
			1	-	-	-	6276049	DS, DSP, KR, LD, LDB1, LDB3, LDM, LHB3, LJ, LJC7, LJG, LSJ, LSS, NJ, NJG, NSJ, NW, PM2, QAB3, QD, RD, RNG, RSS1, SCJ, SD, SDB1, SDB3, SDS2, SJ, SJC, SJC1, SJC5, SJG, SMJ1, SSK1, VED, VS, VSB1, VSX3, VTD, VTD1, VTX, VTX1, VXD, VXD1, WJP
			1	-	-	-	6649704	BL
	30700-ZF5-013	CAP ASSY., NOISE SUPPRESSOR	1	(1)	-	-		VGE4, VPM4, VPM5, VPM7, VPR4, VPR7, VSD1, VS17

Ref. No.	Part No.	Description	Reqd. QTY				Serial No.	Parts catalogue code
			(1)	(2)	(3)	(4)		
(2)	30700-ZE1-013	CAP ASSY., NOISE SUPPRESSOR (NICHIIWA Y-EZ RTFM256)	1	-	1	-	-----	ARC6,EMA,EMA2,HG1,HG12,HH,HHQ4,HH26,HX,HXE,HXE2,HXE8,HXQ,HXU HX2,HX26,HX4,KTA,LAX,LAX2,LH,LHQ4,LHW,LSJ4,LSS4,LX,LXU,LX2 LX26,LX4,NJC1,PH,PHM,PHU,PX,PXU,PX2,QA,QAX,QAX2,QA2,QA26,QBC2 QBT2,QBT6,QBU2,QCB2,QCL,QE,QFE4,QGR2,QGR9,QH,QHE,QHP1,QHQ4 QH26,QI2,QKA4,QMC8,QMD6,QME4,QMH,QMX2,QMZ2,QNT,QNT2,QNT4,QNZ QP,QPU,QSC2,QSC9,QS2,QWA4,QWM2,QWX2,QWX3,QX,QXB,QXB1,QXC,QXC6 QXC9,QXE,QXE2,QXE4,QXE6,QXE8,QXF,QXF2,QXM1,QXG,QXS,QXS2,QXU QXW,QXW2,QX2,QX22,QX26,QX4,QX7,RAC,REX4,RFR,RFR2,RH,RHA,RHA2 RHQ4,RH2,RH26,RMB4,RMG2,RSK,RTB2,RX,RXE,RXE2,RXE4,RXU,RX4,SAC SAD2,SD16,SE,SEE,SG24,SH,SHM,SHQ4,SHRY,SHR4,SMB4,SMC7,SMC9 SMW2,SMX4,SM12,SM14,SNX,SNX1,SSK2,SSX2,STM,STP,STQ,SWG4,SWX SWX2,SWX4,SX,SXB,SXE,SXE4,SXS4,SXU,SX4,SX7,S1CY,TCS2,TH,THU,TX TXC9,TXU,TX2,TX26,TX4,UH,UX,UXU,VA,VA2,VEBM,VEB2,VED1,VED2 VED3,VED5,VED6,VED7,VEN2,VES,VG24,VH,VHA7,VHH4,VHQ4,VIH1,VMB3 VMS4,VMS7,VMT,VSD,VSD7,VSG,VSW,VTE2,VTU1,VWA,VWA2,VW12,VX,VXE VXE4,VXE6,VXE7,VXG,VXM,VXU,VXU1,VXW,VXW1,VXW2,VX2,VX26,VX4 WDA6,WKD6,WKT2,WKT4,WKT6,WME2,WME4,WMT LD4,QMC6,RD4,SDS,SD4,WMB0 3923402 5249929 6276050 ----- ----- ----- DS,DSP,KR,LD,LDB1,LDB3,LDM,LHB3,LJ,LJC7,LJG,LSJ,LSS,NJ,NJG,NSJ NW,PM2,QAB3,QD,RD,RNG,RSS1,SCJ,SD,SDB1,SDB3,SDS2,SJ,SJC,SJC1 SJC5,SJG,SMJ1,SSK1,VED,VS,VS1,VSX3,VD,VD1,VTX,VTX1,VXD,VXD1 WJP 3923401 4224868 ----- ----- ----- QAB1 VSX,VSX1,VS3,VS4 LVL,QVL,QZ BL NJC1 EMA,NSJ,RHA,SMC9,SXP1,VES,VXD,VXD1 STM LHW,LSS LW2,QMC6,QMD6,QP,QXS,QXS2,RMG2,RSK,SDS,SW2 EMA,EMA2,HXE,HXE2,HXE8,LAX,LAX2,LHW,LSS,LSS1,LW2,NSJ,QAX,QAX2 QGR9,QHE,QKA4,QMC6,QMD6,QNZ,QP,QSC2,QSC9,QXE,QXE2,QXE4,QXE6 QXE8,QXS,QXS2,QXW,QXW2,REX4,RHA,RHA2,RMG2,RSK,RXE,RXE2,RXE4 SDS,SEE,SKM,SMC9,SNX1,ST,STM,SW2,SXE,SXE4,SXP1,VES,VSW,VXD VXD1,VXE,VXE4,VXE6,VXE7 EMA,EMA2,HXE,HXE2,HXE8,LAX,LAX2,LHW,LSS,LSS1,LW2,NSJ,QAX,QAX2 QGR9,QHE,QKA4,QMC6,QMD6,QNZ,QP,QSC2,QSC9,QXE,QXE2,QXE4,QXE6 QXE8,QXS,QXS2,QXW,QXW2,REX4,RHA,RHA2,RMG2,RSK,RXE,RXE2,RXE4 SDS,SEE,SKM,SMC9,SNX1,ST,STM,SW2,SXE,SXE4,SXP1,VES,VSW,VXD VXD1,VXE,VXE4,VXE6,VXE7 HXE,HXE2,HXE8,QHE,QKA4,QXE,QXE2,QXE4,QXE6,QXE8,RXE,RXE2,RXE4 SEE,SNX1,ST,SXE,SXE4,VSW,VXE,VXE4,VXE6,VXE7 5641954 ----- ----- ----- STM
	30700-ZE8-003	CAP ASSY., NOISE SUPPRESSOR	1	-	-	-	-----	LVL,QVL,QZ
	30700-ZB6-013	1	-	-	-	-----	BL
3	31510-ZE1-003	COIL ASSY., LAMP (12V/15W) ..	-	(1)	-	-	-----	NJC1
	31510-ZE1-811	COIL ASSY., LAMP (12V/25W) ..	1	-	-	2	-----	EMA,NSJ,RHA,SMC9,SXP1,VES,VXD,VXD1
			2	-	-	-	-----	STM
	31510-ZE1-821	COIL ASSY., LAMP (6V/15W) ...	-	(1)	-	-	-----	LHW,LSS
	31510-ZE1-831	COIL ASSY., LAMP (6V/25W) ...	1	-	-	-	-----	LW2,QMC6,QMD6,QP,QXS,QXS2,RMG2,RSK,SDS,SW2
4	31510-ZE1-711	COIL ASSY., LAMP (12V/50W) ..	1	-	-	-	-----	EMA,EMA2,HXE,HXE2,HXE8,LAX,LAX2,LHW,LSS,LSS1,LW2,NSJ,QAX,QAX2
			-	(1)	-	-	-----	QGR9,QHE,QKA4,QMC6,QMD6,QNZ,QP,QSC2,QSC9,QXE,QXE2,QXE4,QXE6
			-	(1)	-	-	-----	QXE8,QXS,QXS2,QXW,QXW2,REX4,RHA,RHA2,RMG2,RSK,RXE,RXE2,RXE4
5	31510-ZE1-721	COIL ASSY., LAMP & CHARGE ...	-	(1)	-	-	-----	SDS,SEE,SKM,SMC9,SNX1,ST,STM,SW2,SXE,SXE4,SXP1,VES,VSW,VXD
			-	(1)	-	-	-----	VXD1,VXE,VXE4,VXE6,VXE7
6	31511-ZE1-000	CLAMPER, CORD	1	-	-	1	-----	EMA,EMA2,HXE,HXE2,HXE8,LAX,LAX2,LHW,LSS,LSS1,LW2,NSJ,QAX,QAX2
			-	(1)	-	-	-----	QGR9,QHE,QKA4,QMC6,QMD6,QNZ,QP,QSC2,QSC9,QXE,QXE2,QXE4,QXE6
			-	(1)	-	-	-----	QXE8,QXS,QXS2,QXW,QXW2,REX4,RHA,RHA2,RMG2,RSK,RXE,RXE2,RXE4
			-	(1)	-	-	-----	SDS,SEE,SKM,SMC9,SNX1,ST,STM,SW2,SXE,SXE4,SXP1,VES,VSW,VXD
			-	(1)	-	-	-----	VXD1,VXE,VXE4,VXE6,VXE7
7	31512-ZE1-000	GROMMET, CORD	1	-	-	1	-----	EMA,EMA2,HXE,HXE2,HXE8,LAX,LAX2,LHW,LSS,LSS1,LW2,NSJ,QAX,QAX2
			-	(1)	-	-	-----	QGR9,QHE,QKA4,QMC6,QMD6,QNZ,QP,QSC2,QSC9,QXE,QXE2,QXE4,QXE6
			-	(1)	-	-	-----	QXE8,QXS,QXS2,QXW,QXW2,REX4,RHA,RHA2,RMG2,RSK,RXE,RXE2,RXE4
			-	(1)	-	-	-----	SDS,SEE,SKM,SMC9,SNX1,ST,STM,SW2,SXE,SXE4,SXP1,VES,VSW,VXD
			-	(1)	-	-	-----	VXD1,VXE,VXE4,VXE6,VXE7
8	31630-ZE1-003	COIL ASSY., CHARGE (1A)	1	-	-	-	-----	HXE,HXE2,HXE8,QHE,QKA4,QXE,QXE2,QXE4,QXE6,QXE8,RXE,RXE2,RXE4
			1	-	-	-	-----	SEE,SNX1,ST,SXE,SXE4,VSW,VXE,VXE4,VXE6,VXE7
			-	(1)	-	-	-----	5641954 STM



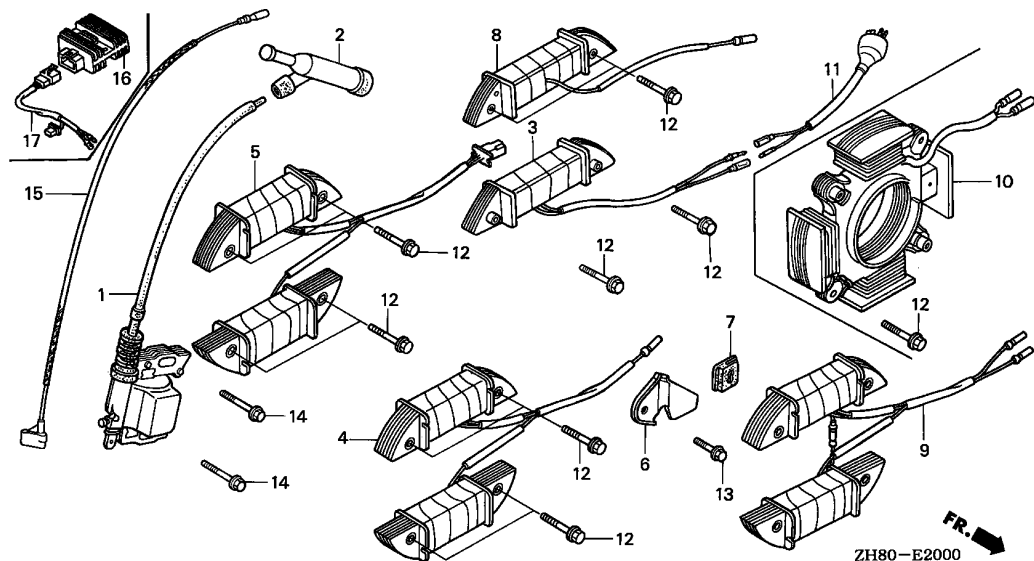

2

Ref. No.	Part No.	Description	Reqd. QTY				Serial No.	Parts catalogue code
			(1)	(2)	(3)	(4)		
9	31630-ZF1-801	COIL ASSY., CHARGE (2.8A) ...	1	-	-	-	LSS1,QXW,QXW2,SKM	
			1	-	-	-	5641955 STM	
10	31630-ZH8-W01	COIL ASSY., CHARGE (12V-7A) .	1	-	-	-	LAX,LAX2,QAX,QAX2,QGR9,QNZ,QSC2,QSC9,REX4	
			-	(1)	-	-		
11	32105-ZE1-000	CABLE, DOUBLE CONNECTOR	-	(1)	-	-		
12	90015-883-000	BOLT, FLANGE, 6X28	2	-	-	4	LVL	
			-	-	-	-	EMA,EMA2,HXE,HXE2,HXE8,LHW,LSS,NSJ,QHE,QKA4,QXE,QXE2,QXE4,QXE6	
			-	-	-	-	QXE8,RHA,RHA2,RXE,RXE2,RXE4,SEE,SMC9,SNX1,SXE,SXE4,SXP1,VES	
			4	-	-	-	VSW,VXD,VXD1,VXE,VXE4,VXE6,VXE7	
13	90019-883-000	BOLT, FLANGE, 5X10	4	-	-	-	LAX,LAX2,LSS1,LW2,QAX,QAX2,QGR9,QMC6,QMD6,QNZ,QP,QSC2,QSC9,QXS	
			-	(4)	-	-	QXS2,QXW,QXW2,REX4,RMG2,RSK,SDS,SKM,SW2	
	90018-ZE1-000	BOLT, FLANGE, 6X23(CT200) ...	-	(2)	-	-		
14	90121-952-000	BOLT, FLANGE, 6X25	2	2	2	2	EMA,EMA2,HXE,HXE2,HXE8,LAX,LAX2,LHW,LSS,LSS1,LW2,NSJ,QAX,QAX2	
			-	(1)	-	-	QGR9,QHE,QKA4,QMC6,QMD6,QNZ,QP,QSC2,QSC9,QXE,QXE2,QXE4,QXE6	
15	36101-ZB2-010	CORD, STOP SWITCH (395MM) ...	1	-	-	-	QXE8,QXS,QXS2,QXW,QXW2,REX4,RHA,RHA2,RMG2,RSK,RXE,RXE2,RXE4	
			1	-	-	-	SDS,SEE,SKM,SMC9,SNX1,ST,STM,SW2,SXE,SXE4,SXP1,VES,VSW,VXD	
	36101-ZE1-010	CORD, STOP SWITCH (370MM) ...	1	-	-	-	VXD1,VXE,VXE4,VXE6,VXE7	
							HXE2,QSC2,QXE2,RXE2,VED2,VED7,VEN2,VES,VSG	
							AR,EMA2,HG12,HXQ,HX2,LAX2,LX2,PX2,QAX2,QA2,QBC2,GBT2,QCB2,QGR2	
							QGR9,QMX2,QMZ2,QSC9,QWM2,QWX2,QWX3,QXC9,QXF2,QXQ,QXS2,QX2,RFR2	
							RHA2,RH2,RMG2,RTB2,SG24,SMW2,SM12,SSK2,SSX2,SWX2,TCS2,TCX9,TX2	
							VA2,VEB2,VG24,VPM7,VPR7,VS17,VWA2,VW12,VXW2,VX2,WKT2,WKT6,WME2	

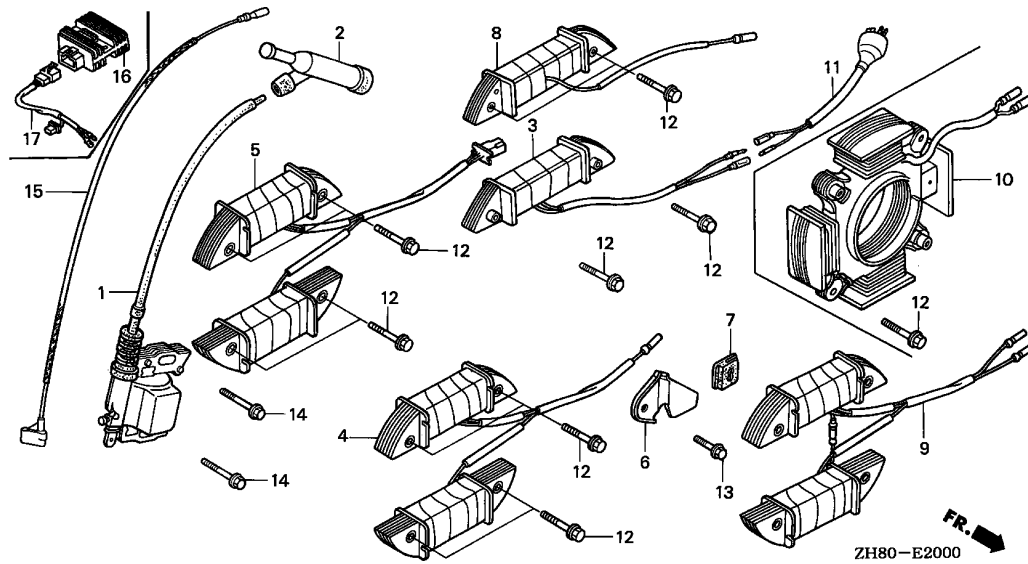

Ref. No.	Part No.	Description	Reqd. QTY				Serial No.	Parts catalogue code
			(1)	(2)	(3)	(4)		
16	31600-ZE2-861	RECTIFIER ASSY., REGULATOR (10A)	1	-	-	-	----- QAX	
17	32110-ZB5-G30	HARNESS ASSY., SUB WIRE	1	-	-	-	----- QAX	



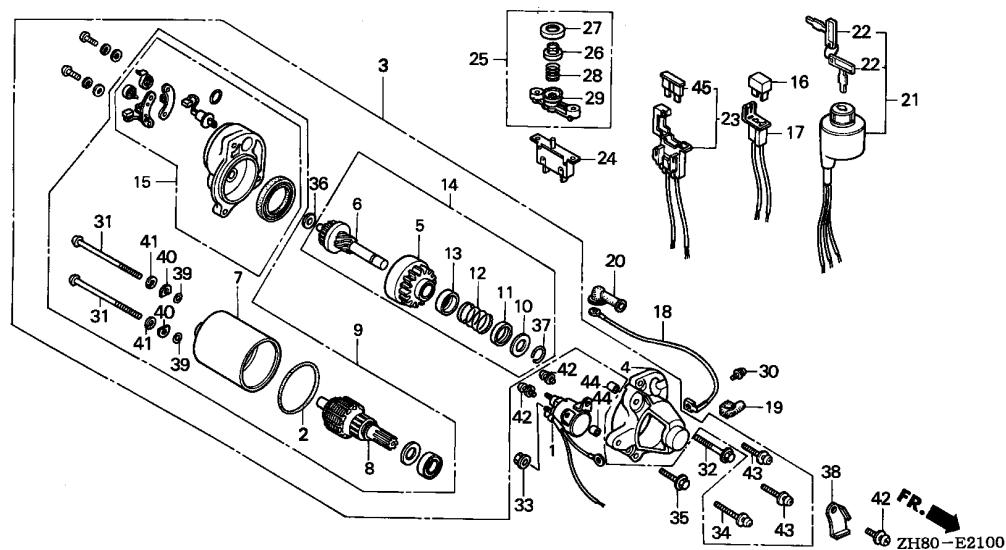

Ref. No.	L.O.N.	(Relative ref. Number) Description	F.R.T.
1	6121C9	SWITCH, STARTER MAGNETIC	0.2
3	6121D5	MOTOR, STARTER	0.2
4	6121B1	COVER, GEAR	0.3
5	6121B0	CLUTCH, OVERRUNNING	0.4
6	6121C6	SHAFT UNIT, GEAR	0.4
7	6121D1	YOKE, STARTER	0.4
8	6121C5	ROTOR, STARTER	0.4
15	6121D2	BRACKET, STARTER :FRONT	0.4
21	6151E1	SWITCH, COMBINATION	0.2
24	6221D4	PROTECTOR, CIRCUIT	0.2

Ref. No.	Part No.	Description	Reqd. QTY				Serial No.	Parts catalogue code
			(1)	(2)	(3)	(4)		
1	31204-ZE1-003	SWITCH COMP., STARTING MAGNET	1	-	-	-	HXE,HXE2,HXE8,QHE,QKA4,QNZ,QSC2,QXE,QXE2,QXE4,QXE6,QXE8,QXW,QXW2,REX4,RXE,RXE2,RXE4,SEE,SNX1,ST,STM,SWG4,SXE,SXE4,VSW,VXE4,VXE6,VXE7	
			1	-	-	-	2833680 SKM	
31204-ZE1-721	SWITCH ASSY., STARTER MAGNETIC	1	(1)	-	-	LSS1		
		1	-	-	-	2833681 SKM		
		1	-	-	-			
2	31206-KN7-670	O-RING	1	(1)	-	-	HXE,HXE2,HXE8,LSS1,QHE,QKA4,QNZ,QSC2,QXE,QXE2,QXE4,QXE6,QXE8,QXW,QXW2,REX4,RXE,RXE2,RXE4,SEE,SKM,SNX1,ST,STM,SWG4,SXE,SXE4,VSW,VXE,VXE4,VXE6,VXE7	
			1	-	-	-		
3	31210-ZE1-023	MOTOR UNIT, STARTER (SM-11203) (162MM)	1	(1)	-	-	HXE,HXE2,HXE8,QHE,QKA4,QNZ,QSC2,QXE,QXE2,QXE4,QXE6,QXE8,QXW,QXW2,REX4,RXE,RXE2,RXE4,SEE,SNX1,SWG4,SXE,SXE4,VSW,VXE,VXE4,VXE6,VXE7	
			1	-	-	-	2653060 ST	
			1	-	-	-	2833680 SKM	
			1	(1)	-	-	LSS1,STM	
31210-ZE1-723	MOTOR UNIT, STARTER (SM-11205) (181MM)	1	-	-	-	2653061 ST		
		1	-	-	-	2833681 SKM		
		1	(1)	-	-			
4	31212-ZE1-003	COVER COMP., GEAR	1	-	-	-	HXE,HXE2,HXE8,LSS1,QHE,QKA4,QNZ,QSC2,QXE,QXE2,QXE4,QXE6,QXE8,QXW,QXW2,REX4,RXE,RXE2,RXE4,SEE,SKM,SNX1,ST,STM,SWG4,SXE,SXE4,VSW,VXE,VXE4,VXE6,VXE7	
			1	(1)	-	-		

Ref. No.	Part No.	Description	Reqd. QTY				Serial No.	Parts catalogue code
			(1)	(2)	(3)	(4)		
5	31214-ZE1-003	PINION ASSY.	1	-	-	-	HXE, HXE2, HXE8, LSS1, QHE, QKA4, QNZ, QSC2, QXE, QXE2, QXE4, QXE6, QXE8, QXW, QXW2, REX4, RXE, RXE2, RXE4, SEE, SKM, SNX1, ST, STM, SWG4, SXE, SXE4, VSW, VXE, VXE4, VXE6, VXE7	
			-	(1)	-	-		
6	31215-ZE1-003	SHAFT UNIT, GEAR	1	-	-	-	HXE, HXE2, HXE8, LSS1, QHE, QKA4, QNZ, QSC2, QXE, QXE2, QXE4, QXE6, QXE8, QXW, QXW2, REX4, RXE, RXE2, RXE4, SEE, SKM, SNX1, ST, STM, SWG4, SXE, SXE4, VSW, VXE, VXE4, VXE6, VXE7	
			-	(1)	-	-		
7	31216-ZE1-003	YOKE ASSY.	1	-	-	-	HXE, HXE2, HXE8, QHE, QKA4, QNZ, QSC2, QXE, QXE2, QXE4, QXE6, QXE8, QXW, QXW2, REX4, RXE, RXE2, RXE4, SEE, SNX1, SWG4, SXE, SXE4, VSW, VXE, VXE4, VXE6, VXE7	
			1	-	-	2653060	ST	
			1	-	-	2833680	SKM	
	31216-ZE1-731	-	(1)	-	-		
			1	-	-		LSS1, STM	
			1	-	-	2653061	ST	
			1	-	-	2833681	SKM	
			-	(1)	-	-		
8	31217-ZE1-013	ROTOR ASSY.	1	-	-	-	HXE, HXE2, HXE8, QHE, QKA4, QNZ, QSC2, QXE, QXE2, QXE4, QXE6, QXE8, QXW, QXW2, REX4, RXE, RXE2, RXE4, SEE, SNX1, SWG4, SXE, SXE4, VSW, VXE, VXE4, VXE6, VXE7	
			1	-	-	2653060	ST	
			1	-	-	2833680	SKM	
			-	(1)	-	-		
	31217-ZE1-722	1	-	-		LSS1, STM	
			1	-	-	2653061	ST	
			1	-	-	2833681	SKM	
			-	(1)	-	-		
9	31220-ZE1-013	MOTOR ONLY	1	-	-	-	HXE, HXE2, HXE8, QHE, QKA4, QNZ, QSC2, QXE, QXE2, QXE4, QXE6, QXE8, QXW, QXW2, REX4, RXE, RXE2, RXE4, SEE, SNX1, SWG4, SXE, SXE4, VSW, VXE, VXE4, VXE6, VXE7	
			1	-	-	2653060	ST	
			1	-	-	2833680	SKM	
			-	(1)	-	-		
	31220-ZE1-722	1	-	-		LSS1, STM	
			1	-	-	2653061	ST	
			1	-	-	2833681	SKM	
			-	(1)	-	-		
10	31221-ZE1-003	PIECE A, STOPPER	1	-	-	-	HXE, HXE2, HXE8, LSS1, QHE, QKA4, QNZ, QSC2, QXE, QXE2, QXE4, QXE6, QXE8, QXW, QXW2, REX4, RXE, RXE2, RXE4, SEE, SKM, SNX1, ST, STM, SWG4, SXE, SXE4, VSW, VXE, VXE4, VXE6, VXE7	
			-	(1)	-	-		
11	31222-ZE1-003	PIECE B, STOPPER	1	-	-	-	HXE, HXE2, HXE8, LSS1, QHE, QKA4, QNZ, QSC2, QXE, QXE2, QXE4, QXE6, QXE8, QXW, QXW2, REX4, RXE, RXE2, RXE4, SEE, SKM, SNX1, ST, STM, SWG4, SXE, SXE4, VSW, VXE, VXE4, VXE6, VXE7	
			-	(1)	-	-		
12	31223-ZE1-003	SPRING, RETURN	1	-	-	-	HXE, HXE2, HXE8, LSS1, QHE, QKA4, QNZ, QSC2, QXE, QXE2, QXE4, QXE6, QXE8, QXW, QXW2, REX4, RXE, RXE2, RXE4, SEE, SKM, SNX1, ST, STM, SWG4, SXE, SXE4, VSW, VXE, VXE4, VXE6, VXE7	
			-	(1)	-	-		
13	31224-ZE1-003	COVER, SPRING	1	-	-	-	HXE, HXE2, HXE8, LSS1, QHE, QKA4, QNZ, QSC2, QXE, QXE2, QXE4, QXE6, QXE8, QXW, QXW2, REX4, RXE, RXE2, RXE4, SEE, SKM, SNX1, ST, STM, SWG4, SXE, SXE4, VSW, VXE, VXE4, VXE6, VXE7	
			-	(1)	-	-		



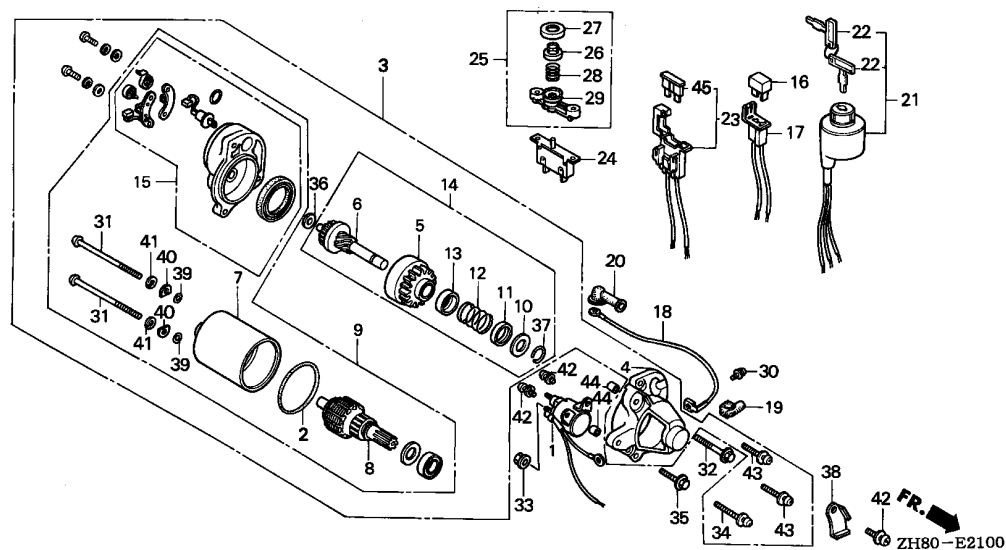

Ref. No.	Part No.	Description	Reqd. QTY				Serial No.	Parts catalogue code
			(1)	(2)	(3)	(4)		
14	31230-ZE1-003	GEAR ASSY.	1	-	-	-	HXE,HXE2,HXE8,LSS1,QHE,QKA4,QNZ,QSC2,QXE,QXE2,QXE4,QXE6,QXE8 QXW,QXW2,REX4,RXE,RXE2,RXE4,SEE,SKM,SNX1,ST,STM,SWG4,SXE,SXE4 VSW,VXE,VXE4,VXE6,VXE7	
15	31235-ZE1-013	BRACKET COMP., FR.	1	(1)	-	-	HXE,HXE2,HXE8,LSS1,QHE,QKA4,QNZ,QSC2,QXE,QXE2,QXE4,QXE6,QXE8 QXW,QXW2,REX4,RXE,RXE2,RXE4,SEE,SKM,SNX1,ST,STM,SWG4,SXE,SXE4 VSW,VXE,VXE4,VXE6,VXE7	
16	31700-124-008	RECTIFIER ASSY., SILICON (SHINDENGEN)	1	-	-	-	VSW 4023626 ST,STM	
17	32130-ZE1-000	COUPLER COMP.	1	(1)	-	-	VSW 4023626 ST,STM	
18	32410-ZE1-000	CORD, MAGNET SWITCH	1	(1)	-	-	HXE,HXE2,HXE8,LSS1,QHE,QKA4,QNZ,QSC2,QXE,QXE2,QXE4,QXE6,QXE8 QXW,QXW2,REX4,RXE,RXE2,RXE4,SEE,SKM,SNX1,ST,STM,SWG4,SXE,SXE4 VSW,VXE,VXE4,VXE6,VXE7	
19	32411-ZE1-000	COVER, MAGNETIC SWITCH	1	(1)	-	-	HXE,HXE2,HXE8,LSS1,QHE,QKA4,QNZ,QSC2,QXE,QXE2,QXE4,QXE6,QXE8 QXW,QXW2,REX4,RXE,RXE2,RXE4,SEE,SKM,SNX1,ST,STM,SWG4,SXE,SXE4 VSW,VXE,VXE4,VXE6,VXE7	
20	32411-253-000	COVER, STARTER MOTOR TERMINAL	1	(1)	-	-	HXE,HXE2,HXE8,LSS1,QHE,QKA4,QNZ,QSC2,QXE,QXE2,QXE4,QXE6,QXE8 QXW,QXW2,REX4,RXE,RXE2,RXE4,SEE,SKM,SNX1,ST,STM,SWG4,SXE,SXE4 VSW,VXE,VXE4,VXE6,VXE7	

Ref. No.	Part No.	Description	Reqd. QTY				Serial No.	Parts catalogue code
			(1)	(2)	(3)	(4)		
21	35100-ZE1-013	SWITCH ASSY., COMBINATION ...	1	-	-	-	VSW	
			1	-	-	-	4023626 ST,STM	
22	35111-880-003	KEY COMP.	-	(1)	-	-	VSW	
			2	-	-	-	4023626 ST,STM	
23	38220-ZE1-000	CASE COMP., FUSE	-	(2)	-	-	VSW	
			1	-	-	-	4023626 ST,STM	
24	38240-VA3-900	PROTECTOR, CIRCUIT (1.0A) ...	1	-	-	-	VSW	
			-	(1)	-	-	4023626 ST,STM	
24	38240-ZE1-000	PROTECTOR, CIRCUIT (1.25A) ..	1	-	-	-	4023626 ST,STM	
			-	(1)	-	-		
25	38250-898-000	LENS ASSY., PROTECTOR	1	-	-	-	VSW	
			1	-	-	-	4023626 ST,STM	
26	38251-898-000	LENS	-	(1)	-	-	VSW	
			1	-	-	-	4023626 ST,STM	
27	38252-898-000	CAP, LENS	1	-	-	-	VSW	
			1	-	-	-	4023626 ST,STM	
28	38253-898-000	SPRING, COIL	-	(1)	-	-	VSW	
			1	-	-	-	4023626 ST,STM	
29	38254-898-000	HOLDER, LENS	-	(1)	-	-	VSW	
			1	-	-	-	4023626 ST,STM	
30	90010-ZE1-003	SCREW-WASHER, 5X8	1	-	-	-	HXE,HXE2,HXE8,LSS1,QHE,QKA4,QNZ,QSC2,QXE,QXE2,QXE4,QXE6,QXE8 QXW,QXW2,REX4,RXE,RXE2,RXE4,SEE,SKM,SNX1,ST,STM,SWG4,SXE,SXE4 VSW,VXE,VXE4,VXE6,VXE7	
			-	(1)	-	-		
31	90012-ZE1-003	BOLT, SETTING	2	-	-	-	HXE,HXE2,HXE8,QHE,QKA4,QNZ,QSC2,QXE,QXE2,QXE4,QXE6,QXE8 QXW2,REX4,RXE,RXE2,RXE4,SEE,SNX1,SWG4,SXE,SXE4,VSW,VXE,VXE4 VXE6,VXE7	
			2	-	-	-	2653060 ST	
			2	-	-	-	2833680 SKM	
			-	(2)	-	-		
			2	-	-	-	LSS1,STM	
90012-ZE1-721	2	-	-	-	2653061 ST		
		2	-	-	-	2833681 SKM		
		-	(2)	-	-			
32	90017-883-000	BOLT, FLANGE, 6X32	1	-	-	-	HXE,HXE2,HXE8,LSS1,QHE,QKA4,QNZ,QSC2,QXE,QXE2,QXE4,QXE6,QXE8 QXW,QXW2,REX4,RXE,RXE2,RXE4,SEE,SKM,SNX1,ST,STM,SWG4,SXE,SXE4 VSW,VXE,VXE4,VXE6,VXE7	
			-	(1)	-	-		
33	90071-MB0-000	NUT-WASHER, 6MM	2	-	-	-	HXE,HXE2,HXE8,LSS1,QHE,QKA4,QNZ,QSC2,QXE,QXE2,QXE4,QXE6,QXE8 QXW,QXW2,REX4,RXE,RXE2,RXE4,SEE,SKM,SNX1,ST,STM,SWG4,SXE,SXE4 VSW,VXE,VXE4,VXE6,VXE7	
			-	(2)	-	-		
34	90115-GB4-700	SCREW-WASHER, 5X30	1	-	-	-	HXE,HXE2,HXE8,LSS1,QHE,QKA4,QNZ,QSC2,QXE,QXE2,QXE4,QXE6,QXE8 QXW,QXW2,REX4,RXE,RXE2,RXE4,SEE,SKM,SNX1,ST,STM,SWG4,SXE,SXE4 VSW,VXE,VXE4,VXE6,VXE7	
			-	(1)	-	-		



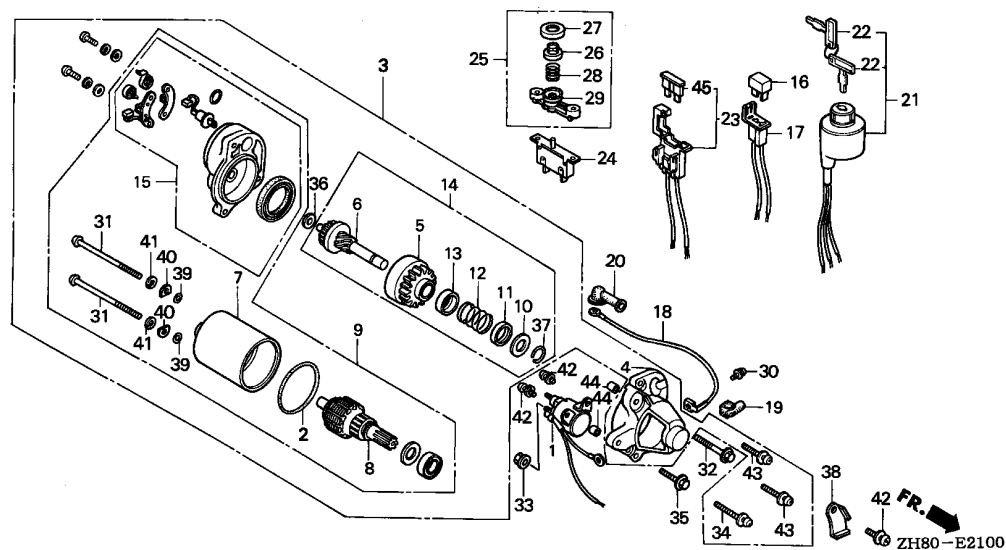

Ref. No.	Part No.	Description	Reqd. QTY				Serial No.	Parts catalogue code
			(1)	(2)	(3)	(4)		
35	90121-952-000	BOLT, FLANGE, 6X25	1	-	-	-	-	HXE,HXE2,HXE8,LSS1,QHE,QKA4,QNZ,QSC2,QXE,QXE2,QXE4,QXE6,QXE8 QXW,QXW2,REX4,RXE,RXE2,RXE4,SEE,SKM,SNX1,ST,STM,SWG4,SXE,SXE4,VSW VXE,VXE4,VXE6,VXE7,WDA6
36	90502-187-701	WASHER, PINION	1	-	-	-	-	HXE,HXE2,HXE8,LSS1,QHE,QKA4,QNZ,QSC2,QXE,QXE2,QXE4,QXE6,QXE8 QXW,QXW2,REX4,RXE,RXE2,RXE4,SEE,SKM,SNX1,ST,STM,SWG4,SXE,SXE4 VSW,VXE,VXE4,VXE6,VXE7
37	90603-ZE1-003	CIRCLIP, 10.2MM	1	-	-	-	-	HXE,HXE2,HXE8,LSS1,QHE,QKA4,QNZ,QSC2,QXE,QXE2,QXE4,QXE6,QXE8 QXW,QXW2,REX4,RXE,RXE2,RXE4,SEE,SKM,SNX1,ST,STM,SWG4,SXE,SXE4 VSW,VXE,VXE4,VXE6,VXE7
38	90631-ZE1-003	HOLDER, HARNESS	1	-	-	-	-	HXE,HXE2,HXE8,QHE,QKA4,QNZ,QSC2,QXE,QXE2,QXE4,QXE6,QXE8,QXW QXW2,REX4,RXE,RXE2,RXE4,SEE,SNX1,ST,STM,SWG4,SXE,SXE4,VSW,VXE VXE4,VXE6,VXE7
			1	-	-	-	2833680	SKM
	90631-ZE1-720	1	-	-	-	-	LSS1
			1	-	-	-	2833681	SKM
39	91301-ZE1-003	O-RING	2	-	-	-	-	HXE,HXE2,HXE8,LSS1,QHE,QKA4,QNZ,QSC2,QXE,QXE2,QXE4,QXE6,QXE8 QXW,QXW2,REX4,RXE,RXE2,RXE4,SEE,SKM,SNX1,ST,STM,SWG4,SXE,SXE4 VSW,VXE,VXE4,VXE6,VXE7
			-	(2)	-	-	-	



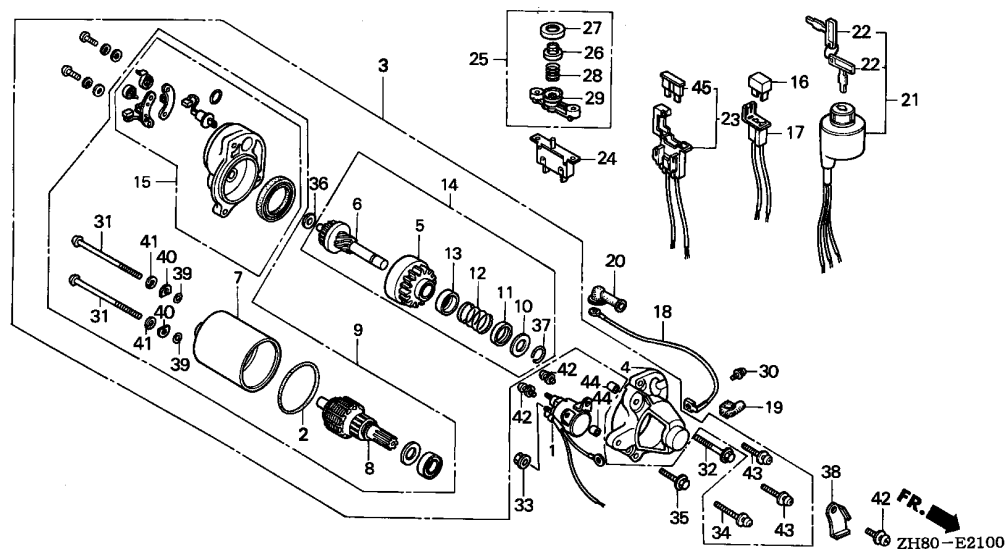

Ref. No.	Part No.	Description	Reqd. QTY				Serial No.	Parts catalogue code
			(1)	(2)	(3)	(4)		
40	91402-ZE6-003	WASHER, SPECIAL	2	-	-	-	HXE,HXE2,HXE8,LSS1,QHE,QKA4,QNZ,QSC2,QXE,QXE2,QXE4,QXE6,QXE8 QXW,QXW2,REX4,RXE,RXE2,RXE4,SEE,SKM,SNX1,ST,STM,SWG4,SXE,SXE4 VSW,VXE,VXE4,VXE6,VXE7	
41	91403-ZE6-003	WASHER, SPRING	2	(2)	-	-	HXE,HXE2,HXE8,LSS1,QHE,QKA4,QNZ,QSC2,QXE,QXE2,QXE4,QXE6,QXE8 QXW,QXW2,REX4,RXE,RXE2,RXE4,SEE,SKM,SNX1,ST,STM,SWG4,SXE,SXE4 VSW,VXE,VXE4,VXE6,VXE7	
42	93892-05014-08	SCREW-WASHER, 5X14	3	(2)	-	-	HXE,HXE2,HXE8,LSS1,QHE,QKA4,QNZ,QSC2,QXE,QXE2,QXE4,QXE6,QXE8 QXW,QXW2,REX4,RXE,RXE2,RXE4,SEE,SKM,SNX1,ST,STM,SWG4,SXE,SXE4 VSW,VXE,VXE4,VXE6,VXE7	
43	93892-05020-08	SCREW-WASHER, 5X20	2	(3)	-	-	HXE,HXE2,HXE8,LSS1,QHE,QKA4,QNZ,QSC2,QXE,QXE2,QXE4,QXE6,QXE8 QXW,QXW2,REX4,RXE,RXE2,RXE4,SEE,SKM,SNX1,ST,STM,SWG4,SXE,SXE4 VSW,VXE,VXE4,VXE6,VXE7	
44	94301-08100	DOWEL PIN, 8X10	2	(2)	-	-	HXE,HXE2,HXE8,LSS1,QHE,QKA4,QNZ,QSC2,QXE,QXE2,QXE4,QXE6,QXE8 QXW,QXW2,REX4,RXE,RXE2,RXE4,SEE,SKM,SNX1,ST,STM,SWG4,SXE,SXE4 VSW,VXE,VXE4,VXE6,VXE7	
45	98200-30500	FUSE, BLADE (5A)	1	(2)	-	-	VSW	
			1	-	-	-	4023676 ST,STM	
			-	(1)	-	-		

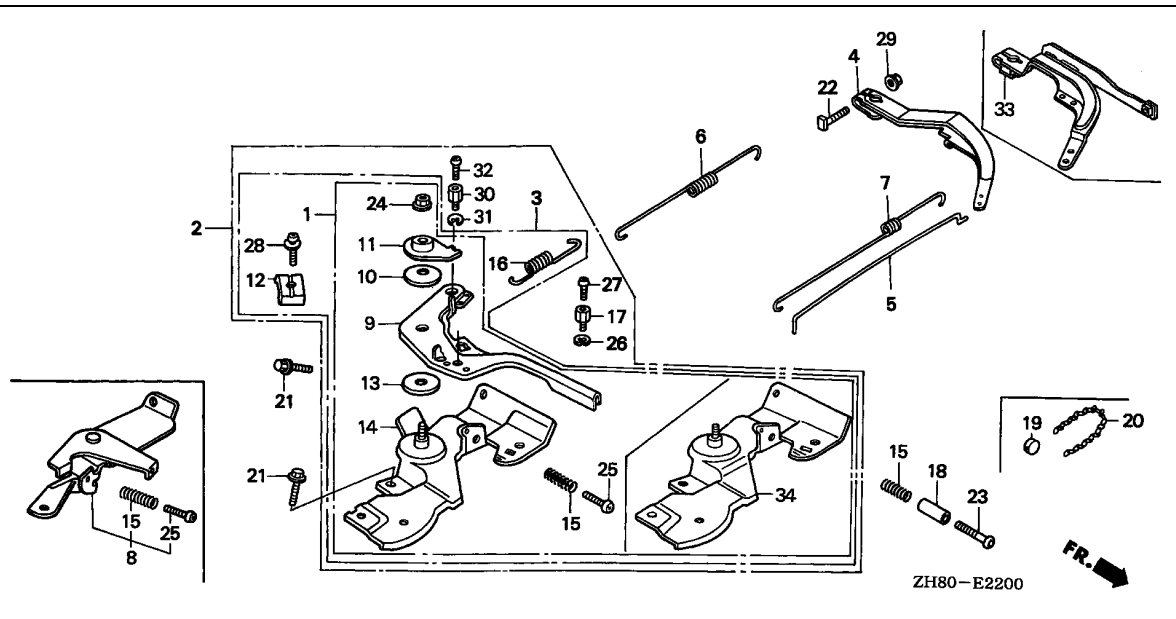

Ref. No.	L.O.N.	(Relative ref. Number) Description	F.R.T.
2	1161A5	CONTROL, THROTTLE/GOVERNOR (33)	0.2
4	1161A0	ARM, GOVERNOR	0.2
5	1161B1	ROD, GOVERNOR	0.3
6	1161C5	SPRING, GOVERNOR	0.2
7	1161C2	SPRING, THROTTLE RETURN	0.3
14	1161A2	BASE, CONTROL (34)	0.3



Ref. No.	Part No.	Description	Reqd. QTY				Serial No.	Parts catalogue code
			(1)	(2)	(3)	(4)		
1	16500-ZH8-000	CONTROL ASSY. (STD.)	1	(1)	-	-	3403754	L1,PH,PHU,PX,PX2,Q1,R1,S1,TH,THU,TX,TX2,TX4,T1,UH,UX,VA,VH,VHQ4,VX,VXE,VXE4,VXW,VXW2,VX2,VX4,V1,WMT,W1
	16500-ZH8-010		-	(1)	-	-	3403755	H1,U1
			1	(1)	-	-	3403755	R1,S1,T1,VA,VHQ4,VXE,VXW,V1
			1	(1)	-	-	5551817	L1,PH,PHU,PX,PX2,Q1,TH,THU,TX,TX2,TX4,UH,UX,VH,VX,VXW2,VX2,WMT,W1
			1	-	-	-	5048176	VXM
			1	-	-	-	5551817	PHM,PXU,TXU,TX26,UXU,VA2,VXE6,VX26,WMB0
			1	-	-	-	3403755	5048176
			-	-	-	1	2000098	VSDP,VXP
16500-ZH8-020	CONTROL ASSY.		1	(1)	-	-	5551818	6196199
			1	-	-	-	6331304	TCS2
			1	-	-	-	5551818	6331304
			-	-	-	1	2000099	2000118
16500-ZH8-030			1	(1)	-	-	6196200	L1,PH,PHM,PHU,PX,PXU,Q1,TH,THU,TXU,TX26,TX4,UH,UX,UXU,VH,VXE6,VX26,WMB0,WME4,W1
			1	-	1	-		WDA6,WIH1
			1	-	-	-	6331305	PX2,TCS2,TX,TX2,VA2,VX,VXW2,VX2,WMT
			-	-	-	1	2000119	VSDP,VXP
16500-ZH8-830	CONTROL ASSY. (LOCK TYPE)		-	(1)	-	-		
16500-ZH8-840	CONTROL ASSY.		-	(1)	-	-		
16500-ZH8-880	CONTROL ASSY. (CYCLONE-STD.)		-	(1)	-	-		H1,U1
16500-ZH8-881			-	(1)	-	-	3427858	L1,Q1,R1,S1,T1,V1,W1
			1	-	-	-	5551817	TXC9
16500-ZH8-882			-	(1)	-	-	3427859	L1,Q1,R1,S1,T1,V1,W1
16500-ZH8-882			1	-	-	-	5551818	6331304
16500-ZH8-883			1	-	-	-	6331305	TXC9

Ref. No.	Part No.	Description	Reqd. QTY				Serial No.	Parts catalogue code
			(1)	(2)	(3)	(4)		
(1)	16500-ZK8-000	CONTROL ASSY.	1	-	-	-	5048177 5551817 VXE4,VXM,VX4	
	16500-ZK8-010	1	-	-	-	5551818 6196199 VXE4,VXM,VX4	
	16500-ZK8-020	1	-	-	-	VXE7	
			1	-	-	-	6196200 ----- VXE4,VXM,VX4	
	16570-ZK8-U30	CONTROL ASSY. (WACKER)	1	-	-	-	4913230 ----- VXD1	
2	16500-ZH8-S40	CONTROL ASSY.	1	-	-	-	3393321 ST,STM	
	16500-ZH8-S41	1	-	-	-	3393322 5551817 ST,STM	
	16500-ZH8-S42	CONTROL ASSY. (TB560)	1	-	-	-	5551818 6331304 ST,STM	
	16500-ZH8-S43	1	-	-	-	QI2	
			1	-	-	-	6331305 ----- ST,STM	
	16500-ZH8-U40	CONTROL ASSY. (NORTON)	1	-	-	-	3432720 QNT	
	16500-ZH8-U41	1	-	-	-	QNT2	
			1	-	-	-	3432721 5551817 QNT	
	16500-ZH8-U42	1	-	-	-	6196199 RSS1	
			1	-	-	-	5551818 6196199 QNT	
	16500-ZH8-U43	1	-	-	-	SMX4	
			1	-	-	-	6196200 ----- QNT,RSS1	
			1	-	-	-	6276085 ----- SM11,SM12,SM14	
			1	-	-	-	6481741 ----- SHRY	
	16500-ZH8-810	CONTROL ASSY. (REMOTE INTL) -	1	(1)	-	-	3393321 DS,DSP,KTA,LJ,LJD,LJG,LSS,LTK,L1,QNZ,Q1,RAC,RSK,R1,SAC,SCJ,SEE	
			1	-	-	-	SJ,SJG,SMJ,SMJ1,SNX,STA,STP,STQ,S1,T1,VEBM,V1,WJP,W1	
			1	-	-	-	3049359 SSK1	
			1	(1)	-	-	H1,U1	
	16500-ZH8-811	1	(1)	-	-	3393322 ----- RAC,SAC,STA,T1,V1	
			1	(1)	-	-	3393322 5551817 KTA,L1,QNZ,Q1,RSK,R1,SEE,S1,VEBM,W1	
			1	-	-	-	QBU2,SAD2,VEB2	
			1	-	-	-	5551817 LSJ4,NW,QMC8,QMD6,QME4,QMX2,QMZ2,SG24,SMC7,SMC9,SMW2,VG24,VMB3	
			-	-	-	1	WKT2,WME2	
	16500-ZH8-812	1	(1)	-	-	2000068 SXP1	
			1	-	-	-	5551818 6196199 KTA,LSJ4,L1,NW,QMC8,QMD6,QME4,QNZ,QWA4,Q1,RSK,R1,SEE,SG24,SMC7	
			1	-	-	1	SMC9,S1,VEBM,VG24,VMB3,WME2,W1	
			1	-	-	-	2000069 2000098 STM,SXP1	
			1	-	-	-	6196199 LHW,SHRY,SHR4,SM11,SM12,SM14,WKT4	
			1	-	-	-	5444480 6196199 DS,DSP,LJ,LJC7,LJG,LSJ,LSS,NJ,NJG,NSJ,RNG,SCJ,SJ,SJC,SJG,SMJ	
			1	-	-	-	SMJ1,SNX,SNX1,STP,STQ,WJP	
	16500-ZH8-813	1	(1)	-	-	5551818 6331304 QMX2,QMZ2,SMW2,WKT2	
			1	(1)	-	-	6196200 ----- DS,DSP,KTA,LHW,LJ,LJC7,LJG,LSJ,LSJ4,LSS,L1,NJ,NJG,NSJ,NW,QMC8	
							QMD6,QME4,QNZ,QWA4,Q1,RNG,RSK,R1,SCJ,SEE,SG24,SHR4,SJ,SJC,SJG	
							SMC7,SMC9,SMJ,SMJ1,SNX,SNX1,STP,STQ,S1,VEBM,VG24,VMB3,WJP,WKT4	
							WME2,W1	
			1	-	-	-	QBC2,S1CY,WKD6,WKT6	
			1	-	-	-	6331305 ----- QMX2,QMZ2,SMW2,WKT2	
			1	-	-	-	6196200 6276084 SM11,SM12,SM14	
			1	-	-	-	6196200 6481740 SHRY	
	16500-ZH8-821	CONTROL ASSY. (REMOTE)	1	(1)	-	-	5551817 Q1,R1,SSK1	
			1	-	-	-	5551817 QXM1	
	16500-ZH8-850	CONTROL ASSY. (CYCLONE)	1	(1)	-	-	3454679 QXC,S1	
			1	(1)	-	-	H1,L1,Q1,R1,T1,U1,V1,W1	
	16500-ZH8-851	1	(1)	-	-	3454680 5551817 QXC,S1	
			1	-	-	-	5551817 QXC6,QXC9	
			-	(1)	-	-	3454680 ----- L1,Q1,R1,T1,V1,W1	
	16500-ZH8-852	1	(1)	-	-	5551818 6196199 QXC6,S1	
			1	-	-	-	5551818 6331304 QXC,QXC9	
	16500-ZH8-853	1	(1)	-	-	6196200 ----- QXC6,S1	
			1	-	-	-	6331305 ----- QXC,QXC9	
	16500-ZH8-860	CONTROL ASSY. (REMOTE)	1	-	-	-	3393321 LJS,LMT	



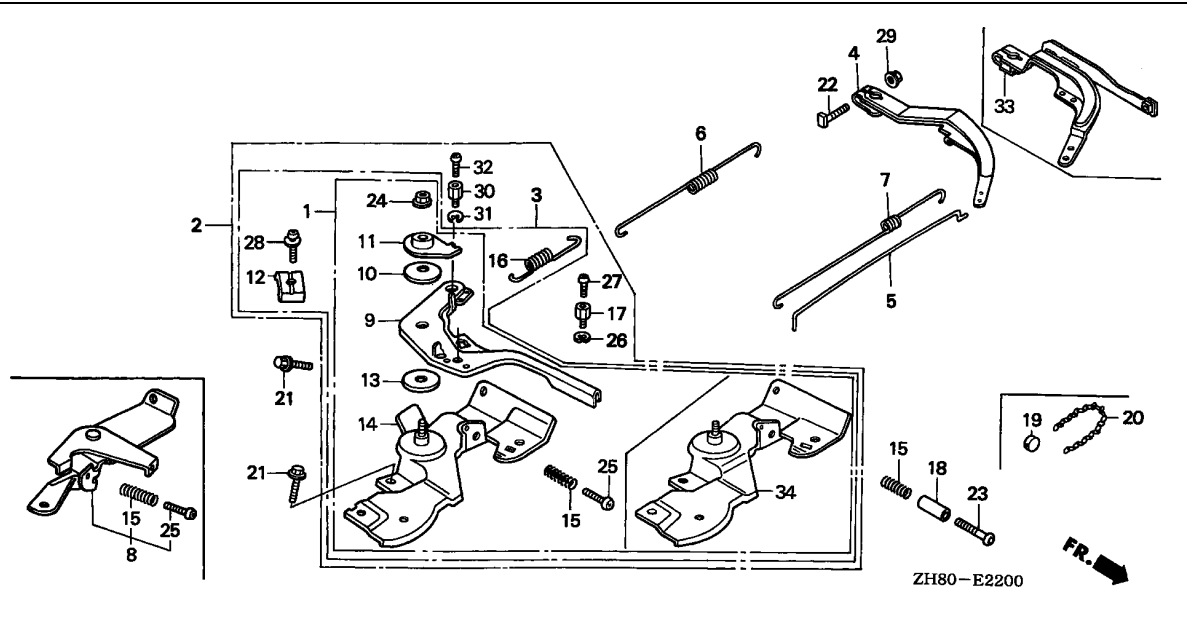

Ref. No.	Part No.	Description	Reqd. QTY				Serial No.	Parts catalogue code
			(1)	(2)	(3)	(4)		
(2)	16500-ZH8-861	CONTROL ASSY. (REMOTE)	1	-	-	-	5551817 AR,ARC6,KR	
	16500-ZH8-862	1	-	-	1	3393322 5551817 LJS,LMT	
	16500-ZH8-863	1	-	-	-	2000099 2000118 STM,SXP1	
	16500-ZH8-890	CONTROL ASSY. (REMOTE INTL-S)	1	-	-	-	5551818 6196199 ARC6	
	16500-ZH8-891	1	-	-	-	5551818 6331304 AR,KR,LJS,LMT	
	16500-ZH8-892	1	-	-	-	2000119 ----- STM,SXP1	
	16500-ZH8-893	1	-	-	-	6196200 ----- ARC6	
	16500-ZK8-910	CONTROL ASSY. (CYCLONE-NORTON)	1	-	-	-	6331305 ----- AR,KR,LJS,LMT,NJC1	
	16500-ZK8-911	1	-	-	-	3393321 RMD	
	16500-ZK8-912	1	-	-	-	2828661 3437688 HG1	
	16500-ZK8-922	CONTROL ASSY. (CYCLONE-EN) ..	-	(1)	-	-	----- H1,U1	
	16570-ZE1-714	CONTROL ASSY. (REMOTE INTL) .	-	(1)	-	-	3437688 L1,Q1,R1,S1,T1,V1,W1	
	16570-ZE1-850	CONTROL ASSY. (CYCLONE)	1	(1)	-	-	3437689 ----- HG1,L1,Q1,S1,T1,V1,W1	
			1	(1)	-	-	3393322 5551817 RMD,R1	
			1	-	-	-	5551817 HG12	
			1	-	-	-	4764119 5551817 SWG4	
			1	(1)	-	-	5551818 6196199 R1,SWG4	
			1	-	-	-	5551818 6331304 HG12,RMD	
			1	(1)	-	-	6196200 ----- R1,SWG4	
			1	-	-	-	6331305 ----- HG12,RMD	
			1	-	-	-	5551817 QNT4	
			1	-	-	-	6331304 QSC9	
			1	-	-	-	5551818 6196199 QNT4	
			1	-	-	-	6196200 ----- QNT4	
			1	-	-	-	6331305 ----- QSC9	
			1	-	-	-	----- LSS4	
			1	-	-	-	----- QXW,QXW2	
			1	-	-	-	----- DS	

Ref. No.	Part No.	Description	Reqd. QTY				Serial No.	Parts catalogue code	
			(1)	(2)	(3)	(4)			
3	16500-ZH8-811	CONTROL ASSY. (REMOTE INTL) -	1	(1)	-	-	3393322	LJD, LTK, STA, V1	
			1	(1)	-	-	3393322	5444479 DS, DSP, LJ, LJG, LSS, L1, Q1, R1, SCJ, SJ, SJG, SMJ, SMJ1, SNX, STP, STQ, S1 WJP, W1	
			1	-	-	-	-----	LSS1	
			1	-	-	-	-----	2000068 STM	
16500-ZH8-820	CONTROL ASSY. (REMOTE)	1	(1)	-	-	-----	5444479 LJC7, LSJ, NJ, NJG, NSJ, RNG, SJC, SNX1	
			1	(1)	-	-	3393321	HH, HHQ4, HX, HXQ, HX2, HX4, LAX, LD, LD4, LH, LHQ4, LTA, LW2, LX, LX2, LX4 L1, PM, PM2, QA, QAX, QA2, QD, QE, QGR2, QH, QHE, QHQ4, QM, QT, QX, QXB, QXE QXE2, QXE4, QXF, QXF2, QXQ, QXS, QXS2, QX2, QX4, Q1, RD, RD4, RFR, RH, RHA RHQ4, RH2, RX, RXE, RXE4, RX4, R1, SD, SDB1, SDS, SD4, SE, SH, SHQ4, SWX, SW2 SX, SXB, SXE, SXE4, SX4, S1, T1, V1, W1	
			1	-	-	-	-----	2828660 HG1	
			1	-	-	-	3049360	3393321 SSK1	
16500-ZH8-821	-	(1)	-	-	-----	H1, U1	
			1	(1)	-	-	3393322	-----	HXQ, LAX, LTA, L1, PM, QAX, QXB, QXF, QXS, RFR, RHA, SWX, SW2, S1, T1, V1, W1
			1	(1)	-	-	3393322	5551817	HH, HHQ4, HX, HX2, HX4, LD, LD4, LH, LHQ4, LW2, LX, LX2, LX4, PM2, QA, QA2, QD QE, QGR2, QH, QHE, QHQ4, QM, QT, QX, QXE, QXE2, QXE4, QXF2, QXQ, QXS2, QX2 QX4, Q1, RD, RD4, RH, RHQ4, RH2, RX, RXE, RXE4, RX4, R1, SD, SDB1, SDS, SD4 SE, SH, SHQ4, SX, SXB, SXE, SXE4, SX4
			1	-	-	-	-----	LAX2, SMB4, SSK2	
16500-ZH8-822	1	-	-	-	-----	4764118 SWG4	
			1	-	-	-	-----	5551817	HH26, HXE, HX26, LDB1, LDB3, LDM, LHB3, LX26, QAB1, QAB3, QAX2, QA26, QBT2 QBT6, QFE4, QHP1, QH26, QKA4, QMC6, QMH, QP, QPU, QWM2, QWX2, QXB1, QXE6 QX26, REX4, RFR2, RHA2, RH26, RMB4, RMG2, RTB2, SDB3, SDN, SDS2, SDS3 SD16, SHM, SSSX2
			1	(1)	-	-	5551818	6196199	HH, HHQ4, HH26, HXE, HXE8, HX26, HX4, LD, LDB1, LDB3, LDM, LD4, LH, LHB3 LHQ4, LW2, LX, LXU, LX26, LX4, PM2, QAB1, QAB3, QA26, QBT2, QBT6, QD, QE QFE4, QH, QHE, QHP1, QHQ4, QH26, QKA4, QM, QMC6, QMH, QP, QPU, QT, QWM2 QWX2, QXB1, QXE4, QXE6, QXE8, QXU, QX26, QX4, Q1, RD, RD4, REX4, RHQ4, RH26 RMB4, RTB2, RX, RXE, RXE4, RXU, RX4, R1, SD, SDB1, SDB3, SDN, SDS, SDS2 SDS3, SD16, SD4, SE, SH, SHM, SHQ4, SSSX2, SX, SXB, SXE, SXE4, SXU, SX4
			1	-	1	-	-----	6196199	HXU, QCB2, QGR9, QIH1, SXS4
16500-ZH8-823	1	-	-	-	5551818	6331304	HX, HX2, LX2, QA, QAX2, QA2, QGR2, QX, QXE, QXE2, QXF2, QXM1, QXQ, QXS2, QX2 RFR2, RH, RHA2, RH2, RMG2, SSK1
			1	(1)	1	-	6196200	-----	HH, HHQ4, HH26, HXE, HXE8, HXU, HX26, HX4, LD, LDB1, LDB3, LDM, LD4, LH LHB3, LHQ4, LW2, LX, LXU, LX26, LX4, PM2, QAB1, QAB3, QA26, QBT2, QBT6 QCB2, QD, QE, QFE4, QGR9, QH, QHE, QHP1, QHQ4, QH26, QIH1, QKA4, QM, QMC6 QMH, QP, QPU, QT, QWM2, QWX2, QXB1, QXE4, QXE6, QXE8, QXU, QX26, QX4, Q1, RD RD4, REX4, RHQ4, RH26, RMB4, RTB2, RX, RXE, RXE4, RXU, RX4, R1, SD, SDB1 SDB3, SDN, SDS, SDS2, SDS3, SD16, SD4, SE, SH, SHM, SHQ4, SSSX2, SX, SXB, SXE SXE4, SXS4, SXU, SX4
			1	-	1	-	-----	-----	BL, HXE2, LVL, QCL, QS2, QVL, QWX3, QX22, QX7, RXE2, SWX2, SWX4, SX7, UIH
			1	-	-	-	6331305	-----	HX, HX2, LX2, QA, QAX2, QA2, QGR2, QX, QXE, QXE2, QXF2, QXM1, QXQ, QXS2, QX2 RFR2, RH, RHA2, RH2, RMG2, SSK1
16500-ZH8-873	CONTROL ASSY. (CYCLONE-REMOTE)	1	-	-	-	-----	-----	QSC2	
16570-ZE1-H33	CONTROL ASSY.	1	-	-	-	-----	-----	SJC1, SJC5	



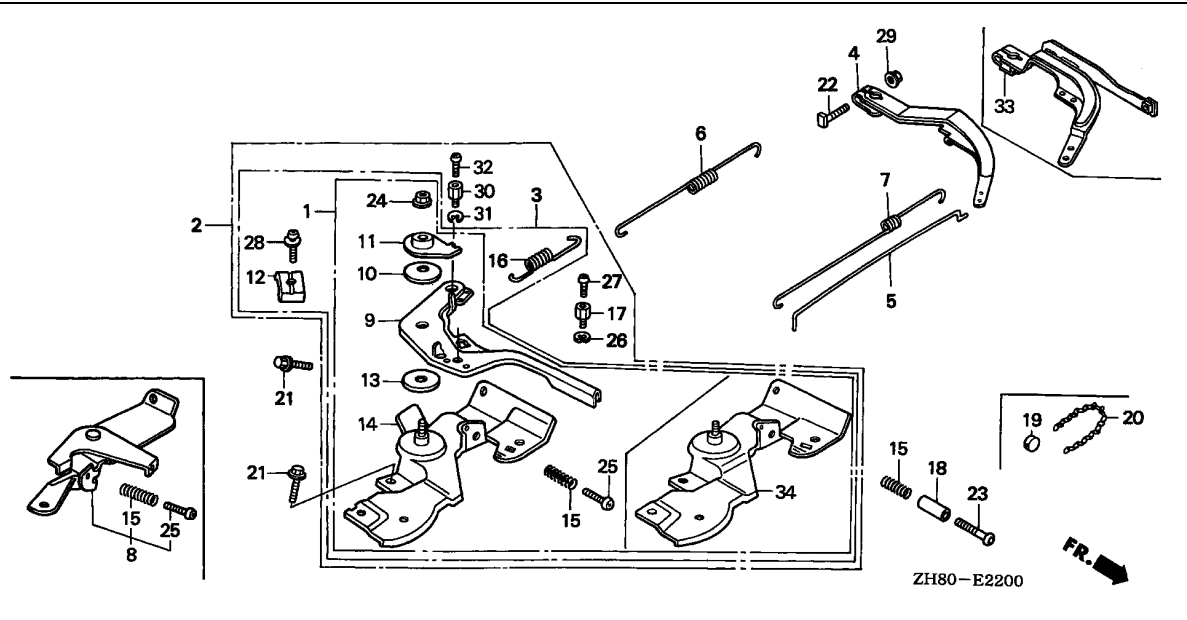

Ref. No.	Part No.	Description	Reqd. QTY				Serial No.	Parts catalogue code
			(1)	(2)	(3)	(4)		
			GX160K1					
4	16551-ZE0-010	ARM, GOVERNOR	1	-	1	-	-----	BL,EMA,EN,ET,ETX,HG1,HG12,HH,HHQ4,HH26,HX,HXE,HXE2,HXE8,HXQ HXU,HX2,HX26,HX4,KTA,LAX,LAX2,LD,LDB1,LDB3,LDM,LD4,LH,LHB3 LHQ4,LHW,LJC7,LJD,LJG,LMT,LSJ,LSJ4,LSS,LSS1,LSS4,LTA,LTK,LVL LW2,LX,LXU,LX2,LX26,LX4,NJ,NJC1,NJG,NSJ,NW,PH,PHM,PHU,PM,PM2 PX,PXU,PX2,QA,QAB1,QAB3,QAX,QAX2,QA2,QA26,QBC2,QBT2,QBT6,QBU2 QCB2,QCL,QD,QE,QFE4,QGR2,QGR9,QH,QHE,QHP1,QHQ4,QH26,QIH1,QI2 QKA4,QM,QMC6,QMC8,QMD6,QME4,QMH,QMX2,QMZ2,QNT,QNT2,QNT4,QNZ,QP QPU,QSC2,QSC9,QS2,QT,QVL,QWA4,QWX2,QWX3,QX,QXB,QXB1,QXC,QXC6 QXC9,QXE,QXE2,QXE4,QXE6,QXE8,QXF,QXF2,QXM1,QXQ,QXS,QXS2,QXU QXW,QXW2,QX2,QX22,QX26,QX4,QX7,RAC,RD,RD4,REX4,RFR,RFR2,RH,RHA RHA2,RHQ4,RH2,RH26,RMB4,RMD,RMG2,RNG,RSK,RSS1,RTB2,RX,RXE,RXE2 RXE4,RXU,RX4,SAC,SAD2,SD,SDB1,SDB3,SDN,SDS,SDS2,SDS3,SD16,SD4 SE,SEE,SG24,SH,SHM,SHQ4,SHRY,SHR4,SJC,SJC1,SJC5,SJG,SMB4,SMC7 SMC9,SMW2,SMX4,SM11,SM12,SM14,SNX,SNX1,SSK1,SSK2,SSX2,STA,STM SWG4,SWX,SWX2,SWX4,SW2,SX,SXB,SXE,SXE4,SXS4,SXU,SX4,SX7,S1CY TCS2,TH,THU,TX,TXC9,TXU,TX2,TX26,TX4,UH,UIH,UX,UXU,VA,VEBM VEB2,VED6,VEN2,VES,VSB1,VTE2,VWA,VXG,VXW,VXW1,WDA6,WI1,WJP WKD6,WKT2,WKT4,WKT6,WMB0,WME2,WME4,WMT VED2,VED7 1 - - - 5048025 ----- 1 - - - 3943828 ----- 1 - - - 4805338 ----- 1 - - - 4913229 ----- EMA2,VA2,VED,VED1,VED3,VED5,VG24,VH,VHH4,VHQ4,VMS4,VS,VSX,VSX1 VS1,VS3,VS4,VW12,VX,VXD,VXD1,VXE,VXE4,VX2,VX26,VX4
	16551-ZE1-010	-	1	-	1	-----	DS,DSP,LJ,LJS,SCJ,SJ,ST,STA,STP,STQ
			-	1	-	-	-----	

Ref. No.	Part No.	Description	Reqd. QTY				Serial No.	Parts catalogue code
			(1)	(2)	(3)	(4)		
(4)	16551-ZL0-000	ARM, GOVERNOR	1	-	1	-	VHA7,VIH1,VMS7,VMT,VPM4,VPM5,VPM7,VPR4,VPR7,VSD7,VSG,VSX3,VS17 VTD,VTD1,VTU1,VTX,VTX1,VXE6,VXE7,VXU1	
			1	-	-	3943829	VGE4,VMB3,VSD,VSD1,VWA2,VXW2	
			1	-	-	4805339	VSW,VXM,VXU	
			1	-	-	4913230	EMA2,VA2,VH,VHH4,VHQ4,VMS4,VS,VSX,VSX1,VS1,VS3,VS4,VW12,VX,VXD VXD1,VXE,VXE4,VX2,VX26,VX4	
			1	-	-	5048024	VED7	
			1	-	-	4913230	5048024 VED,VED1,VED2,VED3,VED5,VG24	
	16550-ZK7-V00	ARM COMP., GOVERNOR	1	-	-	-	AR,ARC6,KR	
	16550-ZK8-900	ARM COMP., GOVERNOR	1	-	-	-	-	
		(WHITENMAN)	1	-	-	-	QWM2	
5	16555-ZE1-000	ROD, GOVERNOR	1	-	-	-	AR,ARC6,BL,DS,DSP,EMA,EMA2,EN,ET,ETX,HG1,HG12,HH,HHQ4,HH26,HX HXE,HXE2,HXE8,HXQ,HXU,HX2,HX26,HX4,KR,KTA,LAX,LAX2,LD,LDB1 LDB3,LDM,LD4,LH,LHB3,LHQ4,LHW,LJ,LJC7,LJD,LJG,LJS,LMT,LSJ,LSJ4 LSS,LSS1,LSS4,LTA,LTK,LVL,LW2,LX,LXU,LX2,LX26,LX4,NJ,NJC1,NJG NSJ,NW,PH,PHM,PHU,PM,PM2,PX,PXU,PX2,QA,QAB1,QAB3,QAX,QAX2,QA2 QA26,QBC2,QBT2,QBT6,QBU2,QCB2,QCL,QD,QE,QFE4,QGR2,QGR9,QH,QHE QHP1,QHQ4,QH26,QI2,QKA4,QM,QMC6,QMC8,QMD6,QME4,QMH,QMX2,QMZ2 QNT,QNT2,QNT4,QNZ,QP,QPU,QSC2,QSC9,QS2,QT,QVL,QWA4,QWM2,QWX2 QWX3,QX,QXB,QXB1,QXC,QXC6,QXC9,QXE,QXE2,QXE4,QXE6,QXE8,QXF QXF2,QXM1,QXQ,QXS,QXS2,QXU,QXW,QXW2,QX2,QX22,QX26,QX4,QX7,RAC RD,RD4,REX4,RFR,RFR2,RH,RHA,RHA2,RHQ4,RH2,RH26,RMB4,RMD,RMG2 RNG,RSK,RSS1,RTB2,RX,RXE,RXE2,RXE4,RXU,RX4,SAC,SAD2,SCJ,SD SDB1,SDB3,SDN,SDS,SDS2,SDS3,SD16,SD4,SE,SEE,SG24,SH,SHM,SHQ4 SHRY,SHR4,SJ,SJC,SJC1,SJC5,SJG,SMB4,SMC7,SMC9,SMJ,SMJ1,SMW2 SMX4,SM11,SM12,SM14,SNX,SNX1,SSK1,SSK2,SSX2,ST,STA,STM,STP,STQ SWG4,SWX,SWX2,SWX4,SW2,SX,SXB,SXE,SXE4,SXS4,SXU,SX4,SX7,S1CY TCS2,TH,THU,TX,TC9,TXU,TX2,TX26,TX4,UH,UX,UXU,VA,VA2,VEBM VEB2,VED,VED1,VED2,VED3,VED5,VED6,VED7,VEN2,VES,VGE4,VG24,VH VHA7,VHH4,VHQ4,VMB3,VMS4,VMS7,VMT,VPM4,VPM5,VPM7,VPR4,VPR7,VS VSB1,VSD,VSD1,VSD7,VSG,VSW,VSX,VSX1,VSX3,VS1,VS17,VS3,VS4,VTD VTD1,VTE2,VTU1,VTX,VTX1,VWA,VWA2,VW12,VX,VXD,VXD1,VXE,VXE4 VXE6,VXE7,VXG,VXM,VXU,VXU1,VXW,VXW1,VXW2,VX2,VX26,VX4,WDA6,WJP WKD6,WKT2,WKT4,WKT6,WMB0,WME2,WME4,WMT	
			-	1	1	1		



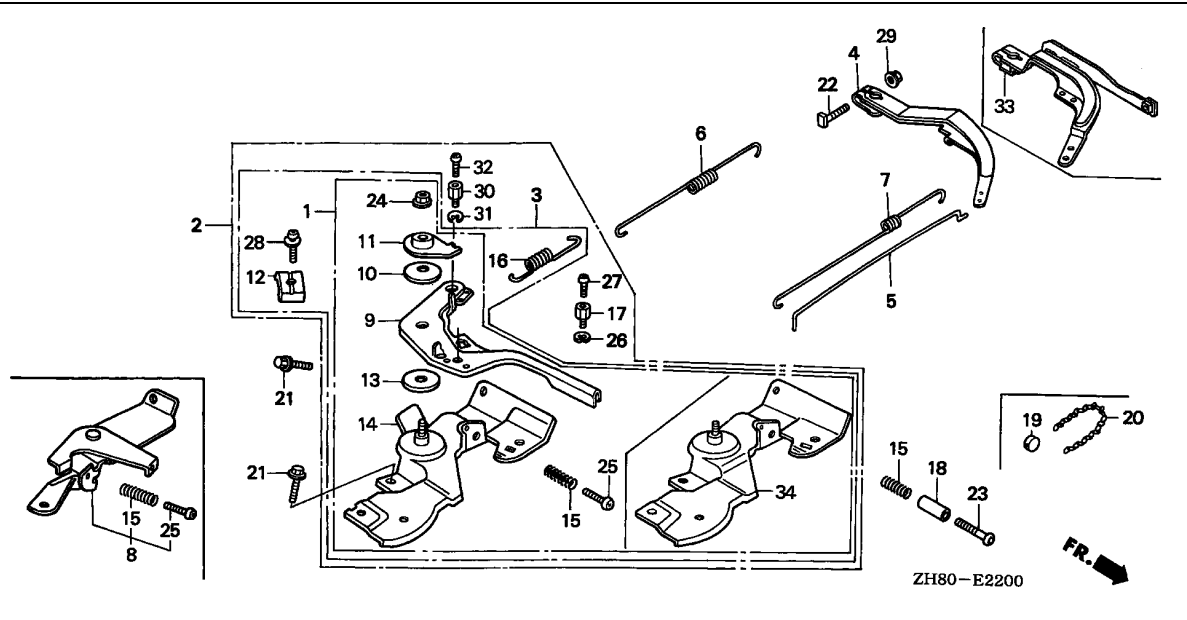

Ref. No.	Part No.	Description	Reqd. QTY				Serial No.	Parts catalogue code
			(1)	(2)	(3)	(4)		
6	16561-ZE1-020	SPRING, GOVERNOR	1	-	1	-	-----	BL,DS,DSP,EN,ET,ETX,HG1,HG12,HH,HHQ4,HH26,HX,HXE,HXE2,HXE8,HXQ HXU,HX2,HX26,HX4,KTA,LAX,LAX2,LD,LDB1,LDB3,LDM,LD4,LH,LHB3 LHQ4,LHW,LJ,LJC7,LJD,LJG,LJS,LMT,LSJ,LSJ4,LSS,LSS1,LSS4,LTA LTK,LVL,LW2,LX,LXU,LX2,LX26,LX4,NJ,NJC1,NJG,NSJ,NW,PH,PHM,PHU PM,PM2,PX,PXU,PX2,QA,QAB1,QAB3,QAX,QAX2,QA2,QA26,QBC2,QBT2 QBT6,QBU2,QCB2,QCL,QD,QE,QFE4,QGR2,QGR9,QH,QHE,QHP1,QHQ4,QH26 QIH1,QI2,QKA4,QM,QMC6,QMC8,QMD6,QME4,QMH,QMX2,QMZ2,QNT,QNT2 QNT4,QNZ,QP,QPU,QSC2,QSC9,QS2,QT,QVL,QWA4,QWM2,QWX2,QWX3,QX QXB,QXB1,QXC,QXC6,QXC9,QXE,QXE2,QXE4,QXE6,QXE8,QXF,QXF2,QXM1 QXQ,QXS,QXS2,QXU,QXW,QXW2,QX2,QX22,QX26,QX4,QX7,RAC,RD,RD4 REX4,RFR,RFR2,RH,RHA,RHA2,RHQ4,RH2,RH26,RMB4,RMD,RMG2,RNG,RSK RSS1,RTB2,RX,RXE,RXE2,RXE4,RXU,RX4,SAC,SAD2,SCJ,SD,SDB1,SDB3 SDN,SDS,SDS2,SDS3,SD16,SD4,SE,SEE,SG24,SH,SHM,SHQ4,SHRY,SHR4 SJ,SJC,SJC1,SJC5,SJG,SMB4,SMC7,SMC9,SMJ,SMJ1,SMW2,SMX4,SM11 SM12,SM14,SNX,SNX1,SSK1,SSK2,SSX2,ST,STA,STM,STP,STQ,SWG4,SWX SWX2,SWX4,SW2,SX,SXB,SXE,SXE4,SXS4,SXU,SX4,SX7,S1CY,TCS2,TH THU,TX,TXC9,TXU,TX2,TX26,TX4,UH,UIH,UX,UXU,VA,VEBM,VEB2,VWA VXW,VXW1,WDA6,WIH1,WJP,WKD6,WKT2,WKT4,WKT6,WMB0,WME2,WME4
			1	-	-	-	-----	2482243 VSD
			1	-	-	-	-----	3943828 VMB3,VWA2,VXW2
			1	-	-	-	-----	4805338 VXM
			1	-	-	-	-----	4913229 VA2,VG24,VH,VHQ4,VS,VSX,VSX1,VS1,VW12,VX,VXE,VXE4,VX2,VX26,VX4
			-	1	-	1	-----	
	16561-ZH8-000	1	-	-	-	-----	EMA,VEN2
			1	-	-	-	-----	3949222 VGE4,VSD1
			1	-	-	-	-----	4805338 VSW,VXU
			1	-	-	-	-----	4913229 EMA2,VED,VED1,VED2,VED3,VED5,VHH4,VMS4,VS3,VS4,VXD,VXD1
			1	-	-	-	2482244	3949222 VSD

Ref. No.	Part No.	Description	Reqd. QTY				Serial No.	Parts catalogue code
			GX160K1					
			(1)	(2)	(3)	(4)		
(6)	16561-ZH8-940	SPRING, GOVERNOR	1	-	-	-	AR,ARC6,KR,WMT	
	16561-ZL0-U30	1	-	1	-	VHA7,VIH1,VMS7,VPM4,VPM5,VPM7,VPR7,VSD7,VSG,VS17,VTD,VTU1,VTX VXE7,VXU1	
			1	-	-	-	3949223 VGE4,VSD,VSD1	
			1	-	-	-	4805339 VXU	
			1	-	-	-	4913230 VHH4,VS,VSX,VS3,VS4,VXD	
			1	-	-	-	5048025 VMS4,VXE4,VXM,VX4	
			1	-	-	-	5048024 VED7	
			1	-	-	-	4805339 5048024 VSW	
			1	-	-	-	4913230 5048024 EMA2,VED,VED1,VED2,VED3,VED5	
	16561-ZH8-D00	1	-	-	-	VED6,VES,VSB1,VTE2,VXG	
			1	-	-	-	5048025 VED,VED1,VED2,VED3,VED7	
	16561-ZL0-000	1	-	-	-	VPR4,VPR7,VSX3,VTD1,VTX1,VXE6	
			1	-	-	-	3943829 VMB3,VWA2,VXW2	
			1	-	-	-	4913230 VA2,VH,VHQ4,VSX1,VS1,VW12,VX,VXD1,VXE,VX2,VX26	
			1	-	-	-	5048025 EMA2,VSW,VS4	
			1	-	-	-	4805339 5048024 VXM	
			1	-	-	-	4913230 5048024 VG24,VMS4,VXE4,VX4	
			1	-	-	-	5048025 VED5,VG24	
	16561-ZE1-020	1	-	-	-		
	7	16562-ZE1-020	SPRING, THROTTLE RETURN	1	-	-	-	AR,ARC6,BL,DS,DSP,EMA,EMA2,EN,ET,ETX,HG1,HG12,HH,HHQ4,HH26,HX HXE,HXE2,HXE8,HXQ,HXU,HX2,HX26,HX4,KR,KTA,LAX,LAX2,LD,LDB1 LDB3,LDM,LD4,LH,LHB3,LHQ4,LHW,LJ,LJC7,LJD,LJG,LJS,LMT,LSJ,LSJ4 LSS,LSS1,LSS4,LTA,LTK,LVL,LW2,LX,LXU,LX2,LX26,LX4,NJ,NJC1,NJG NSJ,NW,PH,PHM,PHU,PM,PM2,PX,PXU,PX2,QA,QAB1,QAB3,QAX,QAX2,QA2 QA26,QBC2,QBT2,QBT6,QBU2,QCB2,QCL,QD,QE,QFE4,QGR2,QGR9,QH,QHE QHP1,QHQ4,QH26,QI2,QKA4,QM,QMC6,QMC8,QMD6,QME4,QMH,QMX2,QM2 QNT,QNT2,QNT4,QNZ,QP,QPU,QSC2,QSC9,QS2,QT,QVL,QWA4,QWM2,QWX2 QWX3,QX,QXB,QXB1,QXC,QXC6,QXC9,QXE,QXE2,QXE4,QXE6,QXE8,QXF QXF2,QXM1,QXQ,QXS,QXS2,QXU,QXW,QXW2,QX2,QX22,QX26,QX4,QX7,RAC RD,RD4,REX4,RFR,RFR2,RH,RHA,RHA2,RHQ4,RH2,RH26,RMB4,RMD,RMG2 RNG,RSK,RSS1,RTB2,RX,RXE,RXE2,RXE4,RXU,RX4,SAC,SAD2,SCJ,SD SDB1,SDB3,SDN,SDS,SDS2,SDS3,SD16,SD4,SE,SEE,SG24,SH,SHM,SHQ4 SHRY,SHR4,SJ,SJC,SJC1,SJC5,SJG,SMB4,SMC7,SMC9,SMJ,SMJ1,SMW2 SMX4,SM11,SM12,SM14,SNX,SNX1,SSK1,SSK2,SSX2,ST,STA,STM,STP,STQ SWG4,SWX,SWX2,SWX4,SW2,SX,SXB,SXE,SXE4,SXS4,SXU,SX4,SX7,S1CY TCS2,TH,THU,TX,TCX9,TXU,TX2,TX26,TX4,UH,UX,UXU,VA,VA2,VEBM VEB2,VED,VED1,VED2,VED3,VED5,VED6,VED7,VEN2,VES,VGE4,VG24,VH VHA7,VHH4,VHQ4,VMB3,VMS4,VMS7,VMT,VPM4,VPM5,VPM7,VPR4,VPR7,VS VSB1,VSD,VSD1,VSD7,VSG,VSW,VSX,VSX1,VSX3,VS1,VS17,VS3,VS4,VTD VTD1,VTE2,VTU1,VTX,VTX1,VWA,VWA2,VW12,VX,VXD,VXD1,VXE,VXE4 VXE6,VXE7,VXG,VXM,VXU,VXU1,VXW,VXW1,VXW2,VX2,VX26,VX4,WDA6,WJP WKD6,WKT4,WKT6,WMB0,WME2,WME4,WMT
		-	1	1	1			
8	16570-ZB2-000	CONTROL ASSY.	1	-	1	-	EN,ET,ETX,VED,VED1,VED3,VED5,VED6,VGE4,VHA7,VHH4,VIH1,VMS7 VPM4,VPM5,VPM7,VS,VSD,VSD7,VSX,VS17,VTD,VTU1,VWA,VXD,VXG,VXU VXU1,VXW1	
			1	-	-	-	4064269 VWA2	
			1	-	-	-	4913229 VMS4,VSX1,VS1,VW12,VXD1	
			1	-	-	-	6111880 VPR4	
16571-ZH8-000	LEVER, CONTROL	1	-	-	-	5551817 QBT2,QWM2,QWX2,RTB2,SG24,SSX2,VG24,WME2		
		1	-	-	-	6331304 QSC9		
16570-ZK8-U30	CONTROL ASSY. (WACKER)	1	-	-	-	VPR7,VSX3,VTD1		
		1	-	-	-	4064270 VWA2		
		1	-	-	-	4913230 VSX1,VS1,VW12		
		1	-	-	-	6111881 VPR4		
		1	-	-	-	4913230 5048024 VMS4		
16570-ZB2-000	CONTROL ASSY.	1	-	-	-	5048025 VMS4		



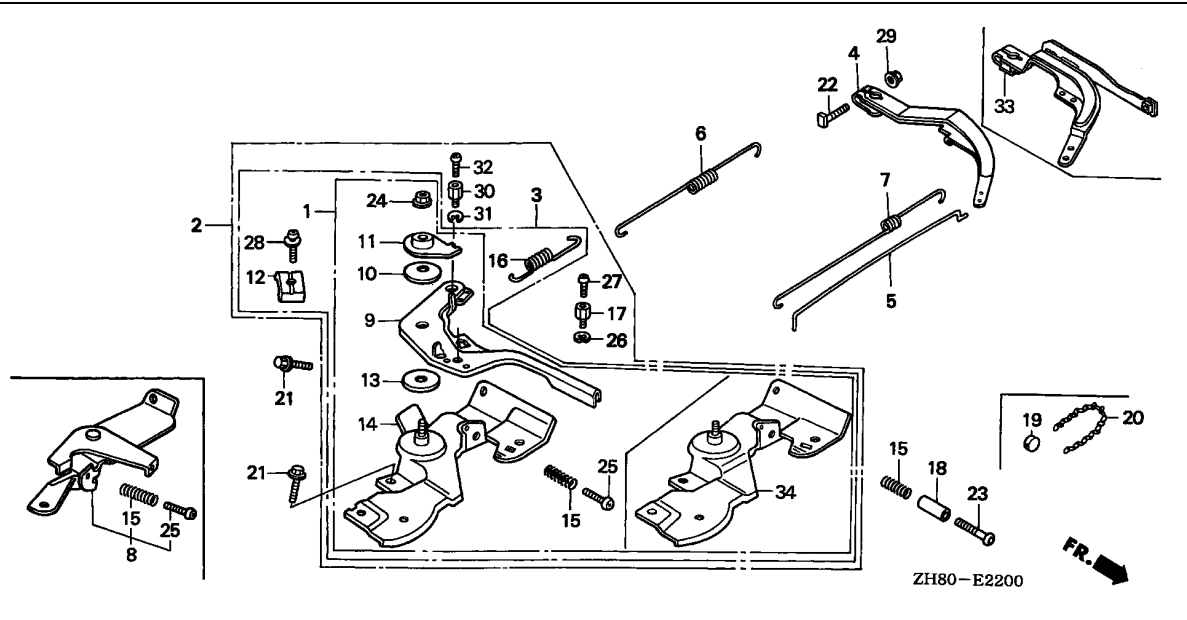

Ref. No.	Part No.	Description	Reqd. QTY				Serial No.	Parts catalogue code
			(1)	(2)	(3)	(4)		
9	16571-ZH8-000	LEVER, CONTROL	1	(1)	-	1	-----	HG1, HXQ, H1, LAX, LAX2, LJD, LSS1, LTA, LTK, PM, QAX, QBU2, QNT2, QXB, QXF, QXS, RAC, RFR, RHA, SAC, SAD2, SMB4, SSK2, STA, STM, SWX, SW2, SXP1, T1, U1, VA, VEB2, VHQ4, VXE, VXW, V1
			1	(1)	-	-	5551817	DS, DSP, HG12, HH, HHQ4, HH26, HX, HXE, HX2, HX26, HX4, KTA, LD, LDB1, LDB3, LDM, LD4, LH, LHB3, LHQ4, LJ, LJC7, LJG, LSJ, LSJ4, LSS, LSS4, LW2, LX, LX2, LX26, LX4, L1, NJ, NJG, NSJ, NW, PH, PHM, PHU, PM2, PX, PX2, QA, QAB1, QAB3, QAX2, QA2, QA26, QBT6, QD, QE, QFE4, QGR2, QH, QHE, QHP1, QHQ4, QH26, QKA4, QM, QMC6, QMC8, QMD6, QME4, QMH, QMX2, QMZ2, QNT, QNT4, QNZ, QP, QPU, QSC2, QT, QWA4, QX, QXB1, QXC, QXC6, QXC9, QXE, QXE2, QXE4, QXE6, QXF2, QXM1, QXQ, QXS2, QXW, QXW2, QX2, QX26, QX4, Q1, RD, RD4, REX4, RFR2, RH, RHA2, RHQ4, RH2, RH26, RMB4, RMD, RMG2, RNG, RSK, RX, RXE, RXE4, RX4, R1, SCJ, SD, SDB1, SDB3, SDN, SDS, SDS2, SDS3, SD16, SD4, SE, SEE, SH, SHM, SHQ4, SJ, SJC, SJG, SMC7, SMC9, SMJ, SMJ1, SMW2, SNX, SNX1, SSK1, ST, STP, STQ, SWG4, SX, SXB, SXE, SXE4, SX4, S1, TH, THU, TX, TXC9, TX2, TX26, TX4, UH, UX, VA2, VEBM, VH, VMB3, VX, VXE4, VXE6, VXM, VXW2, VX2, VX26, VX4, WJP, WKT2, WMBO, WMT, W1
	16571-ZH8-840	-	(1)	-	-		
	16571-ZH8-S00	1	-	-	-	3303356	AR
		1	-	-	-	5551817	ARC6, KR, LJS, LMT

Ref. No.	Part No.	Description	Reqd. QTY				Serial No.	Parts catalogue code
			GX160K1					
			(1)	(2)	(3)	(4)		
(9)	16571-ZH8-010	LEVER, CONTROL	1	-	-	-	6331304	HXU,LHW,QCB2,QGR9,RSS1,SHRY,SHR4,SM11,SM12,SM14,SXS4,TCS2,WKT4,WME4
			1	-	-	-	5551818	6331304 DS,DSP,HG12,HH,HHQ4,HH26,HX,HXE,HXE8,HX2,HX26,HX4,KTA,LD,LDB1,LDB3,LDM,LD4,LH,LHB3,LHQ4,LJ,LJC7,LJG,LSJ,LSJ4,LSS,LS54,LW2,LX,LXU,LX2,LX26,LX4,NJ,NJG,NSJ,NW,PH,PHM,PHU,PM2,PX,PXU,PX2,QA,QAB1,QAB3,QAX2,QA2,QA26,QBT2,QBT6,QD,QE,QFE4,QGR2,QH,QHE,QHP1,QHQ4,QH26,QKA4,QM,QMC6,QMC8,QMD6,QME4,QMH,QMX2,QMZ2,QNT,QNT4,QNZ,QP,QPU,QSC2,QT,QWA4,QWM2,QWX2,QX,QXB1,QXC,QXC6,QXC9,QXE,QXE2,QXE4,QXE6,QXE8,QXF2,QXM1,QXQ,QXS2,QXU,QXW,QXW2,QX2,QX26,QX4,RD,RD4,REX4,RFR2,RH,RHA2,RHQ4,RH2,RH26,RMB4,RMD,RMG2,RNG,RSK,RTB2,RX,RXE,RXE4,RXU,RX4,SCJ,SD,SDB1,SDB3,SDN,SDS,SDS2,SDS3,SD16,SD4,SE,SEE,SG24,SH,SHM,SHQ4,SJ,SJC,SJG,SMC7,SMC9,SMJ,SMJ1,SMW2,SNX,SNX1,SSK1,SSX2,ST,STM,STP,STQ,SWG4, SX, SXB, SXE, SXE4, SXU, SX4, TH, THU, TX, TXC9, TXU, TX2, TX26, TX4, UH, UX, UXU, VA2, VEBM, VG24, VH, VMB3, VX, VXE4, VXE6, VXM, VXW2, VX2, VX26, VX4, WJP, WKT2, WMB0, WME2, WMT
			-	(1)	-	-	5551818	6196199 L1,Q1,R1,S1,W1
			-	-	-	1	2000118	VSDP,VXP
	16571-ZH8-S01	1	-	-	1	2000099	2000118 STM,SXP1
			1	-	-	-	3303357	6331304 AR
			1	-	-	-	5551818	6196199 ARC6
			1	-	-	-	5551818	6331304 KR,LJS,LMT
	16571-ZH8-020	1	-	1	-	6331305	BL,HXE2,LVL,QBC2,QCL,QIH1,QI2,QS2,QVL,QWX3,QX22,QX7,RXE2,SMX4,SWX2,SWX4,SX7,S1CY,UIH,VXE7,WDA6,WIH1,WKD6,WKT6
			1	-	-	-	6331305	DS,DSP,HG12,HH,HHQ4,HH26,HX,HXE,HXE8,HXU,HX2,HX26,HX4,KTA,LD,LDB1,LDB3,LDM,LD4,LH,LHB3,LHQ4,LHW,LJ,LJC7,LJG,LSJ,LSJ4,LSS,LS54,LW2,LX,LXU,LX2,LX26,LX4,NJ,NJG,NSJ,NW,PH,PHM,PHU,PM2,PX,PXU,PX2,QA,QAB1,QAB3,QAX2,QA2,QA26,QBT2,QBT6,QCB2,QD,QE,QFE4,QGR2,QGR9,QH,QHE,QHP1,QHQ4,QH26,QKA4,QM,QMC6,QMC8,QMD6,QME4,QMH,QMX2,QMZ2,QNT,QNT4,QNZ,QP,QPU,QSC2,QSC9,QT,QWA4,QWM2,QWX2,QX,QXB1,QXC,QXC6,QXC9,QXE,QXE2,QXE4,QXE6,QXE8,QXF2,QXM1,QXQ,QXS2,QXU,QXW,QXW2,QX2,QX26,QX4,RD,RD4,REX4,RFR2,RH,RHA2,RHQ4,RH2,RH26,RMB4,RMD,RMG2,RNG,RSK,RSS1,RTB2,RX,RXE,RXE4,RXU,RX4,SCJ,SD,SDB1,SDB3,SDN,SDS,SDS2,SDS3,SD16,SD4,SE,SEE,SG24,SH,SHM,SHQ4,SHRY,SHR4,SJ,SJC,SJG,SMC7,SMC9,SMJ,SMJ1,SMW2,SM11,SM12,SM14,SNX,SNX1,SSK1,SSX2,ST,STM,STP,STQ,SWG4, SX, SXB, SXE, SXE4, SXS4, SXU, SX4, TCS2, TH, THU, TX, TXC9, TXU, TX2, TX26, TX4, UH, UX, UXU, VA2, VEBM, VG24, VH, VMB3, VX, VXE4, VXE6, VXM, VXW2, VX2, VX26, VX4, WJP, WKT2, WKT4, WMB0, WME2, WME4, WMT
			-	(1)	-	-	6196200	L1,Q1,R1,S1,W1
			-	-	-	1	2000119	VSDP,VXP
	16571-ZH8-S02	1	-	-	1	2000119	STM,SXP1
			1	-	-	-	6196200	NJC1
			1	-	-	-	6196200	ARC6
			1	-	-	-	6331305	AR,KR,LJS,LMT
	16571-ZE1-H30	LEVER COMP., CONTROL	1	-	-	-	5551817	SJC1,SJC5
	16571-ZE1-H31	1	-	-	-	5551818	6331304 SJC1,SJC5
	16571-ZE1-H32	1	-	-	-	6331305	SJC1,SJC5



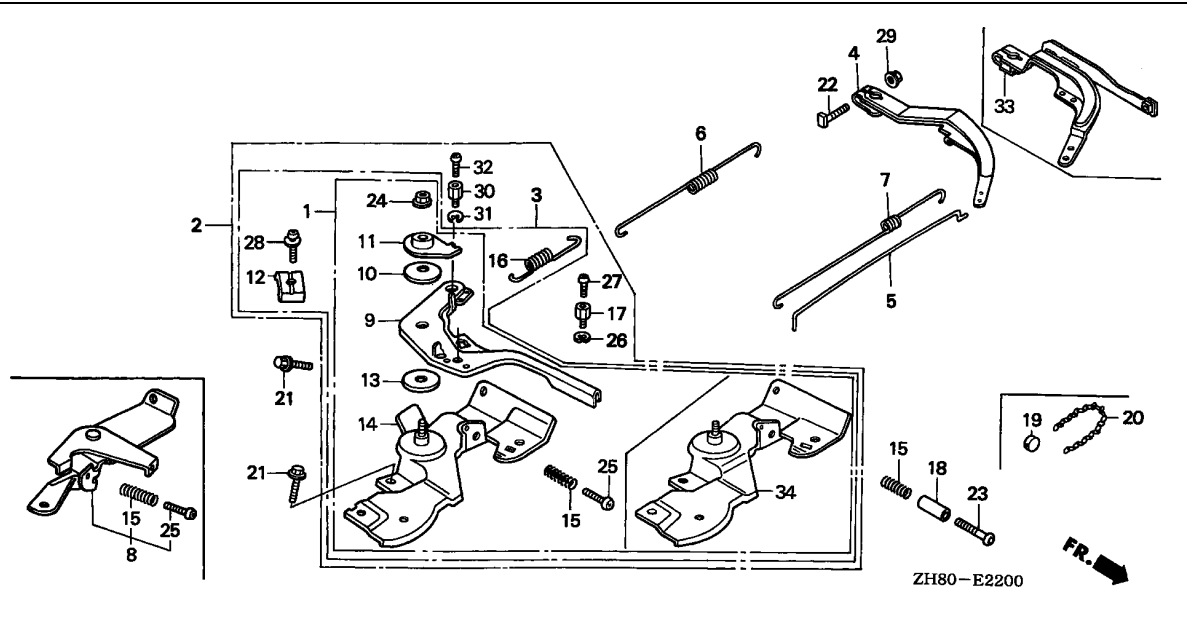

Ref. No.	Part No.	Description	Reqd. QTY				Serial No.	Parts catalogue code
			(1)	(2)	(3)	(4)		
10	16574-ZE1-000	SPRING, LEVER	1	-	1	-	AR,ARC6,BL,DS,DSP,HG1,HG12,HH,HHQ4,HH26,HX,HXE,HXE2,HXE8,HXQ HXU,HX2,HX26,HX4,KR,KTA,LAX,LAX2,LD,LDB1,LDB3,LDM,LD4,LH,LHB3 LHQ4,LHW,LJ,LJC7,LJD,LJG,LJS,LMT,LSJ,LSJ4,LSS,LSS1,LSS4,LTA LTK,LVL,LW2,LX,LXU,LX2,LX26,LX4,NJ,NJC1,NJG,NSJ,NW,PH,PHM,PHU PM,PM2,PX,PXU,PX2,QA,QAB1,QAB3,QAX,QAX2,QA2,QA26,QBC2,QBT2 QBT6,QBU2,QCB2,QCL,QD,QE,QFE4,QGR2,QGR9,QH,QHE,QHP1,QHQ4,QH26 QIH1,QI2,QKA4,QM,QMC6,QMC8,QMD6,QME4,QMH,QMX2,QMZ2,QNT,QNT2 QNT4,QNZ,QP,QPU,QSC2,QSC9,QS2,QT,QVL,QWA4,QWM2,QWX2,QWX3,QX QXB,QXB1,QXC,QXC6,QXC9,QXE,QXE2,QXE4,QXE6,QXE8,QXF,QXF2,QXM1 QXQ,QXS,QXS2,QXU,QXW,QXW2,QX2,QX22,QX26,QX4,QX7,RAC,RD,RD4 REX4,RFR,RFR2,RH,RHA,RHA2,RHQ4,RH2,RH26,RMB4,RMD,RMG2,RNG,RSK RSS1,RTB2,RX,RXE,RXE2,RXE4,RXU,RX4,SAC,SAD2,SCJ,SD,SDB1,SDB3 SDN,SDS,SDS2,SDS3,SD16,SD4,SE,SEE,SG24,SH,SHM,SHQ4,SHRY,SHR4 SJ,SJC,SJC1,SJC5,SJG,SMB4,SMC7,SMC9,SMJ,SMJ1,SMW2,SMX4,SM11 SM12,SM14,SNX,SNX1,SSK1,SSK2,SSX2,ST,STA,STM,STP,STQ,SWG4,SWX SWX2,SWX4,SW2,SX,SXB,SXE,SXE4,SXS4,SXU,SX4,SX7,S1CY,TCS2,TH THU,TX,TXC9,TXU,TX2,TX26,TX4,UH,UIH,UX,UXU,VA,VA2,VEBM,VEB2 VG24,VH,VHQ4,VMB3,VX,VXE,VXE4,VXE6,VXE7,VXM,VXW,VXW2,VX2,VX26 VX4,WDA6,WIH1,WJP,WKD6,WKT2,WKT4,WKT6,WMB0,WME2,WME4,WMT	
			- (1) - 1					

Ref. No.	Part No.	Description	Reqd. QTY				Serial No.	Parts catalogue code
			GX160K1					
			(1)	(2)	(3)	(4)		
11	16575-ZH8-000	WASHER, CONTROL LEVER	1	-	1	-	AR,ARC6,BL,DS,DSP,HG1,HG12,HH,HHQ4,HH26,HX,HXE,HXE2,HXE8,HXQ HXU,HX2,HX26,HX4,KR,KTA,LAX,LAX2,LD,LDB1,LDB3,LDM,LD4,LH,LHB3 LHQ4,LHW,LJ,LJC7,LJD,LJG,LJS,LMT,LSJ,LSJ4,LSS,LSS1,LSS4,LTA LTK,LVL,LW2,LX,LXU,LX2,LX26,LX4,NJ,NJC1,NJG,NSJ,NW,PH,PHM,PHU PM,PM2,PX,PXU,PX2,QA,QAB1,QAB3,QAX,QAX2,QA2,QA26,QBC2,QBT2 QBT6,QBU2,QCB2,QCL,QD,QE,QFE4,QGR2,QGR9,QH,QHE,QHP1,QHQ4,QH26 QIH1,QI2,QKA4,QM,QMC6,QMC8,QMD6,QME4,QMH,QMX2,QMZ2,QNT,QNT2 QNT4,QNZ,QP,QPU,QSC2,QSC9,QS2,QT,QVL,QWA4,QWM2,QWX2,QWX3,QX QXB,QXB1,QXC,QXC6,QXC9,QXE,QXE2,QXE4,QXE6,QXE8,QXF,QXF2,QXM1 QXQ,QXS,QXS2,QXU,QXW,QXW2,QX2,QX22,QX26,QX4,QX7,RAC,RD,RD4 REX4,RFR,RFR2,RH,RHA,RHA2,RHQ4,RH2,RH26,RMB4,RMD,RMG2,RNG,RSK RSS1,RTB2,RX,RXE,RXE2,RXE4,RXU,RX4,SAC,SAD2,SCJ,SD,SDB1,SDB3 SDN,SDS,SDS2,SDS3,SD16,SD4,SE,SEE,SG24,SH,SHM,SHQ4,SHRY,SHR4 SJ,SJC,SJC1,SJC5,SJG,SMB4,SMC7,SMC9,SMJ,SMJ1,SMW2,SMX4,SM11 SM12,SM14,SNX,SNX1,SSK1,SSK2,SSX2,ST,STA,STM,STP,STQ,SWG4,SWX SWX2,SWX4,SW2,SX,SXB,SXE,SXE4,SXS4,SXU,SX4,SX7,S1CY,TCS2,TH THU,TX,TXC9,TXU,TX2,TX26,TX4,UH,UIH,UX,UXU,VA,VA2,VEBM,VEB2 VG24,VH,VHQ4,VMB3,VX,VXE,VXE4,VXE6,VXE7,VXM,VXW,VXW2,VX2,VX26 VX4,WDA6,WIH1,WJP,WKD6,WKT2,WKT4,WKT6,WMB0,WME2,WME4,WMT	
			-	(1)	-	1		
12	16576-891-000	HOLDER, CABLE	1	-	1	1	AR,ARC6,BL,DS,DSP,HG1,HG12,HH,HHQ4,HH26,HX,HXE,HXE2,HXE8,HXQ HXU,HX2,HX26,HX4,KR,KTA,LAX,LAX2,LD,LDB1,LDB3,LDM,LD4,LH,LHB3 LHQ4,LHW,LJ,LJC7,LJD,LJG,LJS,LMT,LSJ,LSJ4,LSS,LSS1,LSS4,LTA LTK,LVL,LW2,LX,LXU,LX2,LX26,LX4,NJ,NJC1,NJG,NSJ,NW,PM,PM2,QA QAB1,QAB3,QAX,QAX2,QA2,QA26,QBC2,QBT2,QBT6,QBU2,QCB2,QCL,QD,QE QFE4,QGR2,QGR9,QH,QHE,QHP1,QHQ4,QH26,QIH1,QI2,QKA4,QM,QMC6 QMC8,QMD6,QME4,QMH,QMX2,QMZ2,QNT,QNT2,QNT4,QNZ,QP,QPU,QSC2 QSC9,QS2,QT,QVL,QWA4,QWM2,QWX2,QWX3,QX,QXB,QXB1,QXC,QXC6,QXC9 QXE,QXE2,QXE4,QXE6,QXE8,QXF,QXF2,QXM1,QXQ,QXS,QXS2,QXU,QXW QXW2,QX2,QX22,QX26,QX4,QX7,RAC,RD,RD4,REX4,RFR,RFR2,RH,RHA RHA2,RHQ4,RH2,RH26,RMB4,RMD,RMG2,RNG,RSK,RSS1,RTB2,RX,RXE,RXE2 RXE4,RXU,RX4,SAC,SAD2,SCJ,SD,SDB1,SDB3,SDN,SDS,SDS2,SDS3,SD16 SD4,SE,SEE,SG24,SH,SHM,SHQ4,SHRY,SHR4,SJ,SJC,SJG,SMB4,SMC7 SMC9,SMJ,SMJ1,SMW2,SMX4,SM11,SM12,SM14,SNX,SNX1,SSK1,SSK2,SSX2 STA,STM,STP,STQ,SWG4,SWX,SWX2,SWX4,SW2,SX,SXB,SXE,SXE4,SXP1 SXS4,SXU,SX4,SX7,S1CY,UIH,VEBM,VEB2,VG24,VMB3,WJP,WKD6,WKT2 WKT4,WKT6,WME2	
			-	(1)	-	-		



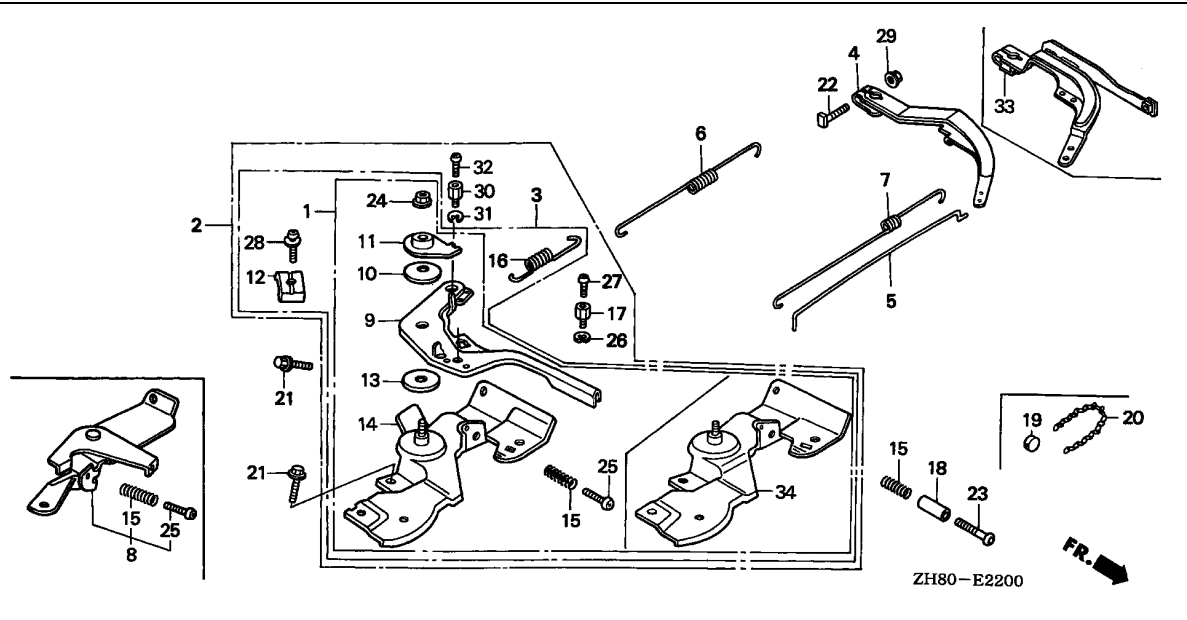

Ref. No.	Part No.	Description	Reqd. QTY				Serial No.	Parts catalogue code
			(1)	(2)	(3)	(4)		
13	16578-ZE1-000	SPACER, CONTROL LEVER	1	-	1	-	-----	AR,ARC6,BL,DS,DSP,HG1,HG12,HH,HHQ4,HH26,HX,HXE,HXE2,HXE8,HXQ HXU,HX2,HX26,HX4,KR,KTA,LAX,LAX2,LD,LDB1,LDB3,LDM,LD4,LH,LHB3 LHQ4,LHW,LJ,LJC7,LJD,LJG,LJS,LMT,LSJ,LSJ4,LSS,LSS1,LSS4,LTA LTK,LVL,LW2,LX,LXU,LX2,LX26,LX4,NJ,NJC1,NJG,NSJ,NW,PH,PHM,PHU PM,PM2,PX,PXU,PX2,QA,QAB1,QAB3,QAX,QAX2,QA2,QA26,QBC2,QBT2 QBT6,QBU2,QCB2,QCL,QD,QE,QFE4,QGR2,QGR9,QH,QHE,QHP1,QHQ4,QH26 QIH1,QI2,QKA4,QM,QMC6,QMC8,QMD6,QME4,QMH,QMX2,QMZ2,QNT,QNT2 QNT4,QNZ,QP,QPU,QSC2,QSC9,QS2,QT,QVL,QWA4,QWM2,QWX2,QWX3,QX QXB,QXB1,QXC,QXC6,QXC9,QXE,QXE2,QXE4,QXE6,QXE8,QXF,QXF2,QXM1 QXQ,QXS,QXS2,QXU,QXW,QXW2,QX2,QX22,QX26,QX4,QX7,RAC,RD,RD4 REX4,RFR,RFR2,RH,RHA,RHA2,RHQ4,RH2,RH26,RMB4,RMD,RMG2,RNG,RSK RSS1,RTB2,RX,RXE,RXE2,RXE4,RXU,RX4,SAC,SAD2,SCJ,SD,SDB1,SDB3 SDN,SDS,SDS2,SDS3,SD16,SD4,SE,SEE,SG24,SH,SHM,SHQ4,SHRY,SHR4 SJ,SJC,SJC1,SJC5,SJG,SMB4,SMC7,SMC9,SMJ,SMJ1,SMW2,SMX4,SM11 SM12,SM14,SNX,SNX1,SSK1,SSK2,SSX2,ST,STA,STM,STP,STQ,SWG4,SWX SWX2,SWX4,SW2,SX,SXB,SXE,SXE4,SXS4,SXU,SX4,SX7,S1CY,TCS2,TH THU,TX,TXC9,TXU,TX2,TX26,TX4,UH,UIH,UX,UXU,VA,VA2,VEBM,VEB2 VG24,VH,VHQ4,VMB3,VX,VXE,VXE4,VXE6,VXE7,VXM,VXW,VXW2,VX2,VX26 VX4,WDA6,WIH1,WJP,WKD6,WKT2,WKT4,WKT6,WMB0,WME2,WME4,WMT
14	16580-ZH8-000	BASE COMP., CONTROL	1	(1)	-	-	-----	3403754 L1,PH,PHU,PX,PX2,QZ,Q1,R1,S1,TH,THU,TX,TX2,TX4,T1,UH,UX,VA,VH VHQ4,VX,VXE,VXE4,VXW,VXW2,VX2,VX4,V1,WMT,W1 H1,U1

Ref. No.	Part No.	Description	Reqd. QTY				Serial No.	Parts catalogue code	
			(1)	(2)	(3)	(4)			
14)	16580-ZH8-810	BASE COMP., CONTROL (REMOTE)	1	(1)	-	-	----- 3393321	DS,DSP,HG1,HH,HHQ4,HX,HXQ,HX2,HX4,KTA,LAX,LD,LD4,LH,LHQ4,LJ,LJD,LJG,LJS,LMT,LSS,LTA,LTK,LW2,LX,LX2,LX4,L1,PM,PM2,QA,QAX,QA2,QD,QE,QGR2,QH,QHE,QHQ4,QM,QNT,QNZ,QT,QX,QXB,QXE,QXE2,QXE4,QXF,QXF2,QXQ,QXS,QXS2,QXW,QX2,QX4,Q1,RAC,RD,RD4,RFR,RH,RHA,RHQ4,RH2,RMD,RSK,RX,RXE,RXE4,RX4,R1,SAC,SCJ,SD,SDB1,SDS,SD4,SE,SEE,SH,SHQ4,SJ,SJG,SMJ,SMJ1,SNX,SSK1,ST,STA,STM,STP,STQ,SWX,SW2,SX,SXB,SXE,SXE4,SX4,S1,T1,VEBM,V1,WJP,W1	
	16580-ZH8-850	BASE COMP., CONTROL (CYCLONE)	-	(1)	-	-	----- 3435940	H1,U1 L1,QXC,Q1,R1,S1,T1,V1,W1	
	16580-ZH8-811	BASE COMP., CONTROL (REMOTE)	1	(1)	-	-	----- 3393322	H1,U1 HG1,HXQ,LAX,LTA,PM,QAX,QXB,QXF,QXS,RAC,RFR,RHA,SAC,STA,SWX,SW2,T1,V1	
			1	(1)	-	-	----- 3393322	5551817	HH,HHQ4,HX,HX2,HX4,KTA,LD,LD4,LH,LHQ4,LW2,LX,LX2,LX4,L1,PM2,QA,QA2,QD,QE,QGR2,QH,QHE,QHQ4,QM,QNT,QNZ,QT,QX,QXE,QXE2,QXE4,QXF2,QXQ,QXS2,QXW,QX2,QX4,Q1,RD,RD4,RH,RHQ4,RH2,RSK,RX,RXE,RXE4,RX4,R1,SD,SDB1,SDS,SD4,SE,SEE,SH,SHQ4,SX,SXB,SXE,SXE4,SX4,S1,VEBM,W1
			1	-	-	-	-----	LAX2,QBU2,QNT2,SAD2,SMB4,SSK2,VEB2	
			1	-	-	-	----- 5551817	AR,ARC6,HG12,HH26,HXE,HX26,LDB1,LDB3,LDM,LHB3,LSJ4,LX26,NW,QAB1,QAB3,QAX2,QA26,QBT2,QBT6,QFE4,QHP1,QH26,QKA4,QMC6,QMC8,QMD6,QME4,QMH,QMX2,QMZ2,QP,QPU,QWA4,QWM2,QWX2,QXB1,QXE6,QXW2,QX26,REX4,RFR2,RHA2,RH26,RMB4,RMG2,RTB2,SDB3,SDN,SDS2,SDS3,SD16,SG24,SHM,SMC7,SMC9,SMW2,SSX2,SWG4,VG24,VMB3,WKT2,WME2	
15	16584-883-300	SPRING, CONTROL ADJUSTING ...	1	-	-	-	-----	AR,ARC6,BL,DS,DSP,EN,ET,ETX,HG1,HG12,HH,HHQ4,HH26,HX,HXE,HXE2,HXE8,HXQ,HXU,HX2,HX26,HX4,KR,KTA,LAX,LAX2,LD,LDB1,LDB3,LDM,LD4,LH,LHB3,LHQ4,LHW,LJ,LJC7,LJD,LJG,LJS,LMT,LSJ,LSJ4,LSS,LSS1,LSS4,LTA,LTK,LVL,LW2,LX,LXU,LX2,LX26,LX4,NJ,NJC1,NJG,NSJ,NW,PH,PHM,PHU,PM,PM2,PX,PXU,PX2,QA,QAB1,QAB3,QAX,QAX2,QA2,QA26,QBC2,QBT2,QBT6,QBU2,QCB2,QCL,QD,QE,QFE4,QGR2,QGR9,QH,QHE,QHP1,QHQ4,QH26,QI2,QKA4,QM,QMC6,QMC8,QMD6,QME4,QMH,QMX2,QMZ2,QNT,QNT2,QNT4,QNZ,QP,QPU,QSC2,QSC9,QS2,QT,QVL,QWA4,QWM2,QWX2,QWX3,QX,QXB,QXB1,QXC,QXC6,QXC9,QXE,QXE2,QXE4,QXE6,QXE8,QXF,QXF2,QXM1,QXQ,QXS,QXS2,QXU,QXW,QXW2,QX2,QX22,QX26,QX4,QX7,RAC,RD,RD4,REX4,RFR,RFR2,RH,RHA,RHA2,RHQ4,RH2,RH26,RMB4,RMD,RMG2,RNG,RSK,RSS1,RTB2,RX,RXE,RXE2,RXE4,RXU,RX4,SAC,SAD2,SCJ,SD,SDB1,SDB3,SDN,SDS,SDS2,SDS3,SD16,SD4,SE,SEE,SG24,SH,SHM,SHQ4,SHRY,SHR4,SJ,SJC,SJC1,SJC5,SJG,SMB4,SMC7,SMC9,SMJ,SMJ1,SMW2,SMX4,SM11,SM12,SM14,SNX,SNX1,SSK1,SSK2,SSX2,ST,STA,STM,STP,STQ,SWG4,SWX,SWX2,SWX4,SW2,SX,SXB,SXE,SXE4,SXS4,SXU,SX4,SX7,S1CY,TC52,TH,THU,TX,TC9,TXU,TX2,TX26,TX4,UH,UX,UXU,VA,VA2,VEBM,VEB2,VED,VED1,VED3,VED5,VED6,VEN2,VGE4,VG24,VH,VHA7,VHH4,VHQ4,VMB3,VMS4,VMS7,VPM4,VPM5,VPM7,VPR4,VPR7,VS,VSB1,VSD,VSD7,MSG,VSX,VSX1,VSX3,VS1,VS17,VTD,VTD1,VTE2,VTU1,VVA,VVA2,VV12,VX,VXD,VXD1,VXE,VXE4,VXE6,VXE7,VXG,VXM,VXU,VXU1,VXW,VXW1,VXW2,VX2,VX26,VX4,WDA6,WJP,WKD6,WKT2,WKT4,WKT6,WMB0,WME2,WME4,WMT	
			-	(1)	1	1			



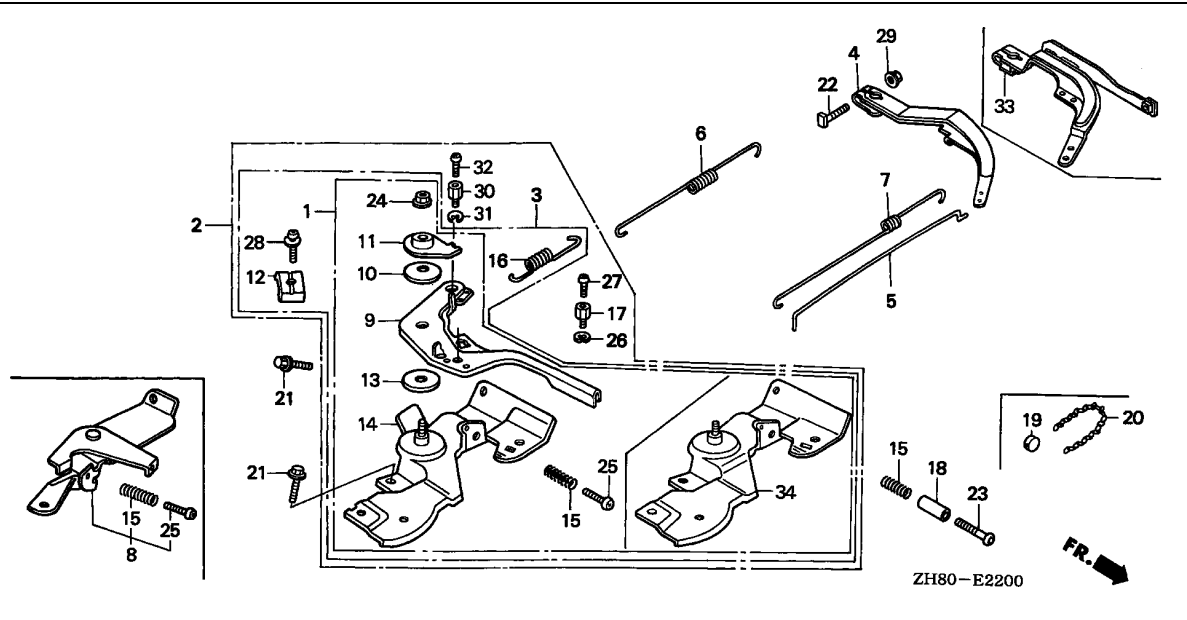

Ref. No.	Part No.	Description	Reqd. QTY				Serial No.	Parts catalogue code
			(1)	(2)	(3)	(4)		
16	16592-ZE1-810	SPRING, CABLE RETURN	1	-	1	1	-----	AR,ARC6,BL,DS,DSP,HG1,HG12,HH,HHQ4,HH26,HX,HXE,HXE2,HXE8,HXQ HXU,HX2,HX26,HX4,KR,KTA,LAX,LAX2,LD,LDB1,LDB3,LDM,LD4,LH,LHB3 LHQ4,LHW,LJ,LJC7,LJD,LJG,LJS,LMT,LSJ,LSJ4,LSS,LSS1,LSS4,LTA LTK,LVL,LW2,LX,LXU,LX2,LX26,LX4,NJ,NJC1,NJG,NSJ,NW,PM,PM2,QA QAB1,QAB3,QAX,QAX2,QA2,QA26,QBC2,QBT2,QBT6,QBU2,QCB2,QCL,QD,QE QFE4,QGR2,QGR9,QH,QHE,QHP1,QHQ4,QH26,QIH1,QI2,QKA4,QM,QMC6 QMC8,QMD6,QME4,QMH,QMX2,QMZ2,QNT,QNT2,QNT4,QNZ,QP,QPU,QSC2 QSC9,QS2,QT,QVL,QWA4,QWM2,QWX2,QWX3,QX,QXB,QXB1,QXC,QXC6,QXC9 QXE,QXE2,QXE4,QXE6,QXE8,QXF,QXF2,QXM1,QXQ,QXS,QXS2,QXU,QXW QXW2,QX2,QX22,QX26,QX4,QX7,RAC,RD,RD4,REX4,RF,RF2,RH,RHA RHA2,RHQ4,RH2,RH26,RMB4,RMD,RMG2,RNG,RSK,RSS1,RTB2,RX,RXE,RXE2 RXE4,RXU,RX4,SAC,SAD2,SCJ,SD,SDB1,SDB3,SDN,SDS,SDS2,SDS3,SD16 SD4,SE,SEE,SG24,SH,SHM,SHQ4,SHRY,SHR4,SJ,SJC,SJG,SMB4,SMC7 SMC9,SMJ,SMJ1,SMW2,SMX4,SM11,SM12,SM14,SNX,SNX1,SSK1,SSK2,SSX2 ST,STA,STM,STP,STQ,SWG4,SWX,SWX2,SWX4,SW2,SX,SXB,SXE,SXE4,SXP1 SXS4,SXU,SX4,SX7,S1CY,UIH,VEBM,VEB2,VG24,VMB3,WJP,WKD6,WKT2 WKT4,WKT6,WME2
			-	(1)	-	-		

Ref. No.	Part No.	Description	Reqd. QTY				Serial No.	Parts catalogue code	
			(1)	(2)	(3)	(4)			
17	16594-883-010	HOLDER, WIRE	1	-	-	1	-----	AR,ARC6,DS,DSP,HG12,KR,KTA,LHW,LJ,LJC7,LJD,LJG,LJS,LMT,LSJ,LSJ4,LSS,LSS1,LSS4,LTK,NJ,NJC1,NJG,NSJ,NW,QBC2,QBU2,QI2,QMC8,QMD6,QME4,QMX2,QMZ2,QNT,QNT2,QNT4,QNZ,QSC9,QWA4,QXC,QXC6,QXC9,QXW,QXW2,RAC,RMD,RNG,RSK,RSS1,SAC,SAD2,SCJ,SEE,SG24,SHRY,SHR4,SJ,SJC,SJG,SMC7,SMC9,SMJ,SMJ1,SMW2,SMX4,SM12,SM14,SNX,SNX1,ST,STA,STM,STP,STQ,SXP1,S1CY,VEBM,VEB2,VG24,VMB3,WJP,WKD6,WKT2,WKT4,WKT6,WME2	
			1	-	-	-	2828661	-----	HG1
			1	-	-	-	4764119	-----	SWG4
			1	-	-	-	6276085	-----	SM11
			1	-	-	-	3049360	-----	SSK1
18	16599-ZG1-M10	COLLAR, STOPPER	1	-	-	(1)	-----	HHQ4,HX4,LD4,LHQ4,LX4,QHQ4,QXE4,QX4,RD4,RHQ4,RXE4,RX4,SD4,SHQ4,SXE4, SX4, TX4, VHQ4, VSDP, VXE4, VX4	
			(1)	-	-	-	-----	-----	LSJ4,LSS4,QFE4,QKA4,QMC6,QMC8,QMD6,QME4,QNT4,QWA4,QX7,REX4,RMB4,SG24,SMB4,SMC7,SMC9,SMX4,SM14,SWG4,SXS4, SX7, S1CY, VGE4, VG24, VHA7, VHH4, VMB3, VMS4, VMS7, VPM4, VPM5, VPM7, VPR4, VPR7, VSD7, VS17, VXE7, WKT4, WMBO
19	16727-705-000	END, LOCK	(1)	-	-	-	3261482	-----	QE,QNT,QXW,RSK,SDS,SE,VSD,VSD1,VXG
20	16729-705-010	WIRE, LOCK	-	(1)	-	-			
21	90016-ZE1-000	BOLT, FLANGE, 6X13(CT200) ...	2	-	-	-	-----	-----	2708336
	90013-883-000	BOLT, FLANGE, 6X12(CT200) ...	2	-	-	-	-----	-----	-----
			2	-	-	-	2708337	-----	HG1,HX,QA,QX,QXC,QXE,QXF,QXS,RFR,RH, TX, VWA, VX, VXW
			-	2	2	2			AR,ARC6,BL,DS,DSP,EN,ET,ETX,HG12,HH,HHQ4,HH26,HXE,HXE2,HXE8,HXQ,HXU,HX2,HX26,HX4,KR,KTA,LAX,LAX2,LD,LDB1,LDB3,LDM,LD4,LH,LHB3,LHQ4,LHW,LJ,LJC7,LJD,LJG,LJS,LMT,LSJ,LSJ4,LSS,LSS1,LSS4,LTA,LTK,LVL,LW2,LX,LXU,LX2,LX26,LX4,NJ,NJC1,NJG,NSJ,NW,PH,PHM,PHU,PM,PM2,PX,PXU,PX2,QAB1,QAB3,QAX,QAX2,QA2,QA26,QBT2,QBT6,QBU2,QCB2,QCL,QD,QE,QFE4,QGR2,QGR9,QH,QHE,QHP1,QHQ4,QH26,QI2,QKA4,QM,QMC6,QMC8,QMD6,QME4,QMH,QMX2,QMZ2,QNT,QNT2,QNT4,QNZ,QP,QPU,QSC2,QSC9,QS2,QT,QVL,QWA4,QWM2,QWX2,QWX3,QXB,QXB1,QXC6,QXC9,QXE2,QXE4,QXE6,QXE8,QXF2,QXM1,QXQ,QXS2,QXU,QXW,QXW2,QX2,QX22,QX26,QX4,QX7,QZ,RAC,RD,RD4,REX4,RFR2,RHA,RHA2,RHQ4,RH2,RH26,RMB4,RMD,RMG2,RNG,RSK,RSS1,RTB2,RX,RXE,RXE2,RXE4,RXU,RX4,SAC,SAD2,SCJ,SD,SDB1,SDB3,SDN,SDS,SDS2,SDS3,SD16,SD4,SE,SEE,SG24,SH,SHM,SHQ4,SHRY,SHR4,SJ,SJC,SJC1,SJC5,SJG,SMB4,SMC7,SMC9,SMJ,SMJ1,SMW2,SMX4,SM11,SM12,SM14,SNX,SNX1,SSK1,SSK2,SSX2,ST,STA,STM,STP,STQ,SWG4,SWX,SWX2,SWX4,SW2,SX,SXB,SXE,SXE4,SXS4,SXU,SX4,SX7,S1CY,TCS2,TH,THU,TCX9, TXU, TX2, TX26, TX4, UH, UX, UXU, VA, VA2, VEBM, VEB2, VED, VED1, VED2, VED3, VED6, VES, VGE4, VG24, VH, VHA7, VHH4, VHQ4, VMB3, VMS4, VMS7, VPM4, VPM5, VPM7, VPR4, VPR7, VS, VSD, VSD1, VSD7, VSX, VSX1, VSX3, VS1, VS17, VTD, VTD1, VTE2, VTU1, VWA2, VW12, VXD, VXD1, VXE, VXE4, VXE6, VXE7, VXG, VXM, VXU, VXU1, VXW1, VXW2, VX2, VX26, VX4, WDA6, WJP, WKD6, WKT2, WKT4, WKT6, WMBO, WME2, WME4, WMT



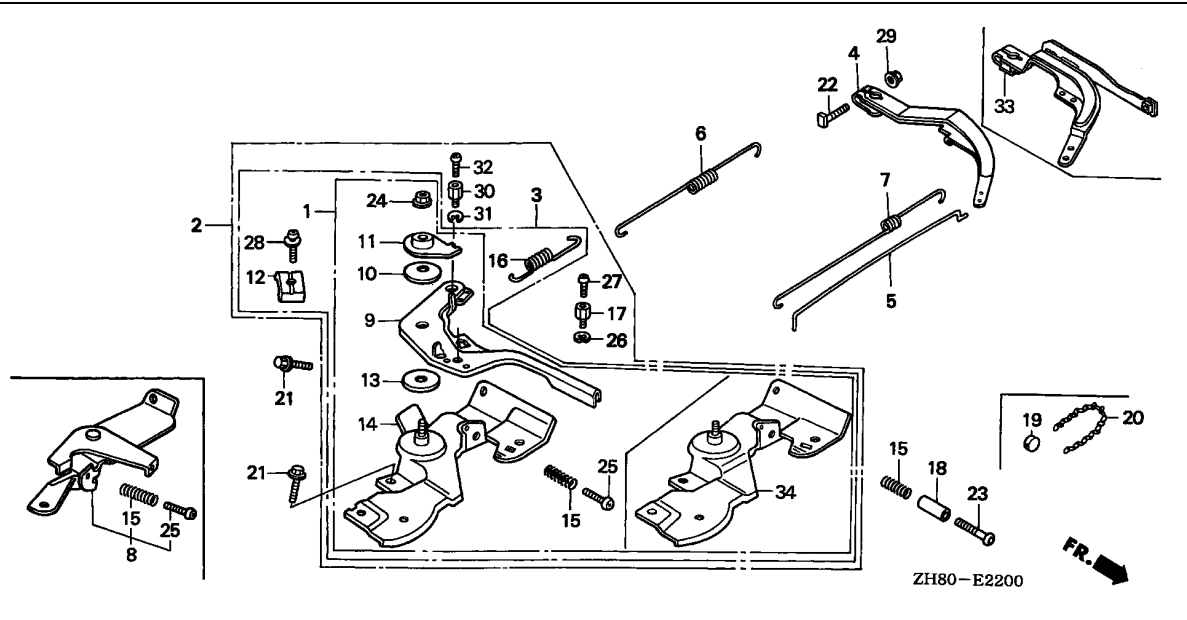

Ref. No.	Part No.	Description	Reqd. QTY				Serial No.	Parts catalogue code
			(1)	(2)	(3)	(4)		
			GX160K1					
			(1)	(2)	(3)	(4)		
22	90015-ZE5-010	BOLT, GOVERNOR ARM	1	-	-	-	-----	AR, ARC6, BL, DS, DSP, EMA, EMA2, EN, ET, ETX, HG1, HG12, HH, HHQ4, HH26, HX, HXE, HXE2, HXE8, HXQ, HXU, HX2, HX26, HX4, KR, KTA, LAX, LAX2, LD, LDB1, LDB3, LDM, LD4, LH, LHB3, LHQ4, LHW, LJ, LJ7, LJC7, LJD, LJG, LJS, LMT, LSJ, LSJ4, LSS, LSS1, LSS4, LTA, LTK, LVL, LW2, LX, LXU, LX2, LX26, LX4, NJ, NJC1, NJG, NSJ, NW, PH, PHM, PHU, PM, PM2, PX, PXU, PX2, QA, QAB1, QAB3, QAX, QAX2, QA2, QA26, QBC2, QBT2, QBT6, QBU2, QCB2, QCL, QD, QE, QFE4, QGR2, QGR9, QH, QHE, QHP1, QHQ4, QH26, QI2, QKA4, QM, QMC6, QMC8, QMD6, QME4, QMH, QMX2, QM2, QNT, QNT2, QNT4, QNZ, QP, QPU, QSC2, QSC9, QS2, QT, QVL, QWA4, QWM2, QWX2, QWX3, QX, QXB, QXB1, QXC, QXC6, QXC9, QXE, QXE2, QXE4, QXE6, QXE8, QXF, QXF2, QXM1, QXQ, QXS, QXS2, QXU, QXW, QXW2, QX2, QX22, QX26, QX4, QX7, RAC, RD, RD4, REX4, RFR, RFR2, RH, RHA, RHA2, RHQ4, RH2, RH26, RMB4, RMD, RMG2, RNG, RSK, RSS1, RTB2, RX, RXE, RXE2, RXE4, RXU, RX4, SAC, SAD2, SCJ, SD, SDB1, SDB3, SDN, SDS, SDS2, SDS3, SD16, SD4, SE, SEE, SG24, SH, SHM, SHQ4, SHRY, SHR4, SJ, SJC, SJC1, SJC5, SJG, SMB4, SMC7, SMC9, SMJ, SMJ1, SMW2, SMX4, SM11, SM12, SM14, SNX, SNX1, SSK1, SSK2, SSS2, ST, STA, STM, STP, STQ, SWG4, SWX, SWX2, SWX4, SW2, SX, SXB, SXE, SXE4, SXS4, SXU, SX4, SX7, S1CY, TCS2, TH, THU, TX, TXC9, TXU, TX2, TX26, TX4, UH, UX, UXU, VA, VA2, VEBM, VEB2, VED, VED1, VED2, VED3, VED5, VED6, VED7, VEN2, VES, VGE4, VG24, VH, VHA7, VHH4, VHQ4, VMB3, VMS4, VMS7, VMT, VPM4, VPM5, VPM7, VPR4, VPR7, VS, VSB1, VSD, VSD1, VSD7, VSG, VSW, VSX, VSX1, VSX3, VS1, VS17, VS3, VS4, VTD, VTD1, VTE2, VTU1, VTX, VTX1, VVA, VVA2, VW12, VX, VXD, VXD1, VXE, VXE4, VXE6, VXE7, VXG, VXM, VXU, VXU1, VXW, VXW1, VXW2, VX2, VX26, VX4, WDA6, WJP, WKD6, WKT2, WKT4, WKT6, WMBO, WME2, WME4, WMT
			- 1 1 1					

Ref. No.	Part No.	Description	Reqd. QTY				Serial No.	Parts catalogue code	
			(1)	(2)	(3)	(4)			
23	90016-ZG9-N30	SCREW, RECESSED, 5X25	1	-	-	(1)	-----	HHQ4, HX4, LD4, LHQ4, LX4, QHQ4, QXE4, QX4, RD4, RHQ4, RXE4, RX4, SD4, SHQ4, SXE4, SX4, TX4, VHQ4, VSDP, VXE4, VX4	
			(1)	-	-	-	-----	LSJ4, LSS4, QFE4, QKA4, QMC6, QMC8, QMD6, QME4, QNT4, QWA4, QX7, REX4, RMB4, SG24, SMB4, SMC7, SMC9, SMX4, SM14, SWG4, SXS4, SX7, S1CY, VGE4, VG24, VHA7, VHH4, VMB3, VMS4, VMS7, VPM4, VPM5, VPM7, VPR4, VPR7, VSD7, VS17, VXE7, WKT4, WMBO	
			(1)	-	-	-	3261482	-----	QE, QNT, QXW, RSK, SDS, SE, VSD, VSD1, VXG
24	90114-SAO-000	NUT, SELF-LOCK, 6MM	1	-	1	-	-----	AR, ARC6, BL, DS, DSP, HG1, HG12, HH, HHQ4, HH26, HX, HXE, HXE2, HXE8, HXQ, HXU, HX2, HX26, HX4, KR, KTA, LAX, LAX2, LD, LDB1, LDB3, LDM, LD4, LH, LHB3, LHQ4, LHW, LJ, LJC7, LJD, LJG, LJS, LMT, LSJ, LSJ4, LSS, LSS1, LSS4, LTA, LTK, LVL, LW2, LX, LXU, LX2, LX26, LX4, NJ, NJC1, NJG, NSJ, NW, PH, PHM, PHU, PM, PM2, PX, PXU, PX2, QA, QAB1, QAB3, QAX, QAX2, QA2, QA26, QBC2, QBT2, QBT6, QBU2, QCB2, QCL, QD, QE, QFE4, QGR2, QGR9, QH, QHE, QHP1, QHQ4, QH26, QIH1, QI2, QKA4, QM, QMC6, QMC8, QMD6, QME4, QMH, QMX2, QM22, QNT, QNT2, QNT4, QNZ, QP, QPU, QSC2, QSC9, QS2, QT, QVL, QWA4, QWM2, QWX2, QWX3, QX, QXB, QXB1, QXC, QXC6, QXC9, QXE, QXE2, QXE4, QXE6, QXE8, QXF, QXF2, QXM1, QXQ, QXS, QXS2, QXU, QXW, QXW2, QX2, QX22, QX26, QX4, QX7, RAC, RD, RD4, REX4, RFR, RFR2, RH, RHA, RHA2, RHQ4, RH2, RH26, RMB4, RMD, RMG2, RNG, RSK, RSS1, RTB2, RX, RXE, RXE2, RXE4, RXU, RX4, SAC, SAD2, SCJ, SD, SDB1, SDB3, SDN, SDS, SDS2, SDS3, SD16, SD4, SE, SEE, SG24, SH, SHM, SHQ4, SHRY, SHR4, SJ, SJC, SJC1, SJC5, SJG, SMB4, SMC7, SMC9, SMJ, SMJ1, SMW2, SMX4, SM11, SM12, SM14, SNX, SNX1, SSK1, SSK2, SSSX2, ST, STA, STM, STP, STQ, SWG4, SWX, SWX2, SWX4, SW2, SX, SXB, SXE, SXE4, SXS4, SXU, SX4, SX7, S1CY, TCS2, TH, THU, TX, TXC9, TXU, TX2, TX26, TX4, UH, UIH, UX, UXU, VA, VA2, VEBM, VEB2, VG24, VH, VHQ4, VMB3, VX, VXE, VXE4, VXE6, VXE7, VXM, VXW, VXW2, VX2, VX26, VX4, WDA6, WIH1, WJP, WKD6, WKT2, WKT4, WKT6, WMBO, WME2, WME4, WMT	
25	90121-ZE1-000	SCREW, LOCK PAN	-	(1)	-	1	-----	H1, U1	
	93500-05025-0A	SCREW, PAN, 5X25	1	-	1	1	2933995	-----	L1, Q1, R1, S1, T1, V1, W1
			1	-	-	-	-----	PH, PHM, PHU, PX, PXU, PX2, TCS2, TH, THU, TX, TXC9, TXU, TX2, TX26, TX4, UH, UX, UXU, VA, VA2, VH, VHQ4, VSDP, VX, VXE, VXE6, VXP, VXW, VXW2, VX2, VX26, WDA6, WIH1, WMBO, WME4, WMT	
			1	-	-	-	5048176	-----	VXE4, VXM, VX4
	93500-05025-0H		1	-	1	1	-----	AR, ARC6, BL, HG1, HG12, HH, HHQ4, HH26, HX, HXE, HXE2, HXE8, HXQ, HXU, HX2, HX26, HX4, KR, KTA, LAX, LAX2, LD, LDB1, LDB3, LDM, LD4, LH, LHB3, LHQ4, LHW, LJC7, LJD, LJG, LSJ, LSJ4, LSS, LSS1, LTA, LVL, LW2, LX, LXU, LX2, LX26, LX4, NJ, NJC1, NJG, NSJ, NW, PM, PM2, QA, QAB1, QAB3, QAX, QAX2, QA2, QA26, QBC2, QBT2, QBT6, QBU2, QCB2, QCL, QD, QE, QFE4, QGR2, QGR9, QH, QHE, QHP1, QHQ4, QH26, QIH1, QI2, QKA4, QM, QMC6, QMC8, QMD6, QME4, QMH, QMX2, QM22, QNT, QNT2, QNT4, QNZ, QP, QPU, QSC2, QSC9, QS2, QT, QVL, QWA4, QWM2, QWX2, QWX3, QX, QXB, QXB1, QXC, QXC6, QXC9, QXE, QXE2, QXE4, QXE6, QXE8, QXF, QXF2, QXM1, QXQ, QXS, QXS2, QXU, QX2, QX22, QX26, QX4, QX7, RD, RD4, REX4, RFR, RFR2, RH, RHA, RHA2, RHQ4, RH2, RH26, RMB4, RMG2, RNG, RSK, RSS1, RTB2, RX, RXE, RXE2, RXE4, RXU, RX4, SAC, SAD2, SD, SDB1, SDB3, SDN, SDS, SDS2, SDS3, SD16, SD4, SE, SG24, SH, SHM, SHQ4, SHRY, SHR4, SJC, SJG, SMB4, SMC7, SMC9, SMW2, SMX4, SM11, SM12, SM14, SNX, SNX1, SSK1, SSK2, SSSX2, STM, SWG4, SWX, SWX2, SWX4, SW2, SX, SXB, SXE, SXE4, SXP1, SXS4, SXU, SX4, SX7, S1CY, UIH, VEB2, VG24, VMB3, WJP, WKD6, WKT2, WKT4, WKT6, WME2	
			1	-	-	-	2628833	-----	DS, DSP, LJ, LTK, RAC, SAC, SCJ, SEE, SJ, SMJ, SMJ1, STA, STP, STQ, VEBM
	90121-ZE0-000	SCREW, LOCK PAN	-	(1)	-	-	2933996	-----	L1, Q1, R1, S1, T1, V1, W1
	93500-05020-0H	SCREW, PAN, 5X20	1	-	-	-	-----	LJS, LMT, QXW, QXW2, RMD, SJC1, SJC5, ST	
			1	-	-	-	2628832	-----	DS, DSP, LJ, LTK, SCJ, SJ, SMJ, SMJ1, STP, STQ
			1	-	-	-	2368081	2628832	RAC, SAC, SEE, STA, VEBM



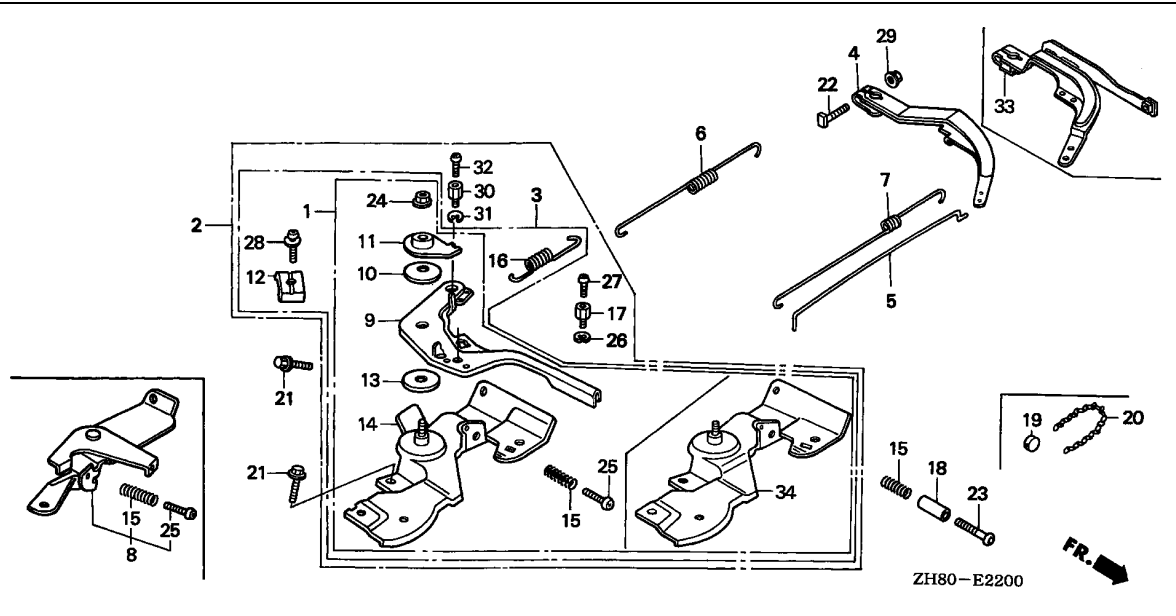

Ref. No.	Part No.	Description	Reqd. QTY				Serial No.	Parts catalogue code
			(1)	(2)	(3)	(4)		
25)	93500-05040-0G	SCREW, PAN, 5X40	1	-	-	-	VPM5, VPR7, VSX3, VTD1	
			1	-	-	-	4064270	VWA2
			1	-	-	-	4913230	VSX1, VS1, VW12, VXD1
			1	-	-	-	6111881	VPR4
			1	-	-	-	4913230	5048024 VMS4
			1	-	-	-	-	VXE7
			1	-	-	-	5048177	VXE4, VXM, VX4
			1	-	1	-	-	EN, ET, ETX, VED, VED1, VED3, VED5, VED6, VGE4, VHA7, VHH4, VIH1, VMS7
			1	-	-	-	-	VPM4, VPM7, VS, VSD, VSD7, VSX, VS17, VTD, VTE2, VTU1, VTX, VWA, VXD, VXG
			1	-	-	-	-	VXU, VXU1, VXW1
			1	-	-	-	5048025	VMS4
			1	-	-	-	4064269	VWA2
26	90605-230-000	CIRCLIP, 5MM	1	-	-	1	AR, ARC6, DS, DSP, HG12, KR, KTA, LHW, LJ, LJC7, LJD, LJG, LJS, LMT, LSJ	
			1	-	-	-	LSJ4, LSS, LSS1, LSS4, LTK, NJ, NJC1, NJG, NSJ, NW, QBC2, QBU2, QI2, QMC8	
			1	-	-	-	QMD6, QME4, QMX2, QMZ2, QNT, QNT2, QNT4, QNZ, QSC9, QWA4, QXC, QXC6, QXC9	
			1	-	-	-	QXW, QXW2, RAC, RMD, RNG, RSK, RSS1, SAC, SAD2, SCJ, SEE, SG24, SHRY, SHR4	
			1	-	-	-	SJ, SJC, SJG, SMC7, SMC9, SMJ, SMJ1, SMW2, SMX4, SM11, SM12, SM14, SNX	
			1	-	-	-	SNX1, ST, STA, STM, STP, STQ, SXP1, S1CY, VEBM, VEB2, VG24, VMB3, WJP, WKD6	
			1	-	-	-	WKT2, WKT4, WKT6, WME2	
			1	-	-	-	2828661	HG1
			1	-	-	-	4764119	SWG4
			1	-	-	-	3049360	SSK1
			-	(1)	-	-	-	-

Ref. No.	Part No.	Description	Reqd. QTY				Serial No.	Parts catalogue code	
			GX160K1						
			(1)	(2)	(3)	(4)			
27	93500-04006-0H	SCREW, PAN, 4X6	1	-	-	1	-----	AR,ARC6,DS,DSP,HG12,KR,KTA,LHW,LJ,LJC7,LJD,LJG,LJS,LMT,LSJ,LSJ4,LSS,LSS1,LSS4,LTK,NJ,NJC1,NJG,NSJ,NW,QBC2,QBU2,QI2,QMC8,QMD6,QME4,QMX2,QMZ2,QNT,QNT2,QNT4,QNZ,QSC9,QWA4,QXC,QXC6,QXC9,QXW,QXW2,RAC,RMD,RNG,RSK,RSS1,SAC,SAD2,SCJ,SEE,SG24,SHRY,SHR4,SJ,SJC,SJG,SMC7,SMC9,SMJ,SMJ1,SMW2,SMX4,SM12,SM14,SNX,SNX1,ST,STA,STM,STP,STQ,SXP1,S1CY,VEBM,VEB2,VG24,VMB3,WJP,WKD6,WKT2,WKT4,WKT6,WME2	
			1	-	-	-	2828661	-----	HG1
			1	-	-	-	4764119	-----	SWG4
			1	-	-	-	6276085	-----	SM11
			1	-	-	-	3049360	-----	SSK1
			-	(1)	-	-			
28	93893-05016-00	SCREW-WASHER, 5X16	1	-	-	-	-----	HXQ,HX2,LX2,QA2,QXE2,QXF2,QXQ,QXS2,QX2,RH2	
			1	-	-	-	2740507	-----	DS,DSP,HH,KTA,LD,LH,LJ,LJS,LMT,LTA,LTK,LW2,LX,PM,PM2,QD,QE,QH,QHE,QM,QNT,QT,QXB,RAC,RD,RX,RXE,SAC,SCJ,SD,SDS,SE,SEE,SH,SJ,SMJ,SMJ1,ST,STA,STP,STQ,SWX,SW2,SX,AXB,SXE,VEBM
			1	-	-	-	2752381	-----	HG1,HX,QA,QX,QXC,QXE,QXF,QXS,RFR,RH
			-	(1)	-	-	2740507	-----	
	93500-05016-0A	SCREW, PAN, 5X16	1	-	1	1	-----	AR,ARC6,BL,HG12,HHQ4,HH26,HXE,HXE2,HXE8,HXU,HX26,HX4,KR,LAX,LAX2,LDB1,LDB3,LDM,LD4,LHB3,LHQ4,LHW,LJC7,LJD,LJG,LSJ,LSJ4,LSS,LSS1,LSS4,LVL,LXU,LX26,LX4,NJ,NJC1,NJG,NSJ,NW,QAB1,QAB3,QAX,QAX2,QA26,QBC2,QBT2,QBT6,QBU2,QCB2,QCL,QFE4,QGR2,QGR9,QHP1,QHQ4,QH26,QIH1,QI2,QKA4,QMC6,QMC8,QMD6,QME4,QMH,QMX2,QMZ2,QNT2,QNT4,QNZ,QP,QPU,QSC2,QSC9,QS2,QVL,QWA4,QWM2,QWX2,QWX3,QXB1,QXC6,QXC9,QXE4,QXE6,QXE8,QXM1,QXU,QXW,QXW2,QX22,QX26,QX4,QX7,RD4,REX4,RFR2,RHA,RHA2,RHQ4,RH26,RMB4,RMD,RMG2,RNG,RSK,RSS1,RTB2,RXE2,RXE4,RXU,RX4,SAD2,SDB1,SDB3,SDN,SDS2,SDS3,SD16,SD4,SG24,SHM,SHQ4,SHRY,SHR4,SJC,SJG,SMB4,SMC7,SMC9,SMW2,SMX4,SM11,SM12,SM14,SNX,SNX1,SSK1,SSK2,SSX2,STM,SWG4,SWX2,SWX4,SXE4,SXP1,SXS4,SXU,SX4,SX7,S1CY,UIH,VEB2,VEB3,VEB4,VEB5,WJP,WKD6,WKT2,WKT4,WKT6,WME2	
			1	-	-	-	2740508	-----	DS,DSP,HH,KTA,LD,LH,LJ,LJS,LMT,LTA,LTK,LW2,LX,PM,PM2,QD,QE,QH,QHE,QM,QNT,QT,QXB,RAC,RD,RX,RXE,SAC,SCJ,SD,SDS,SE,SEE,SH,SJ,SMJ,SMJ1,ST,STA,STP,STQ,SWX,SW2,SX,AXB,SXE,VEBM
			1	-	-	-	2752382	-----	HG1,HX,QA,QX,QXC,QXE,QXF,QXS,RFR,RH
			-	(1)	-	-	2740508	-----	



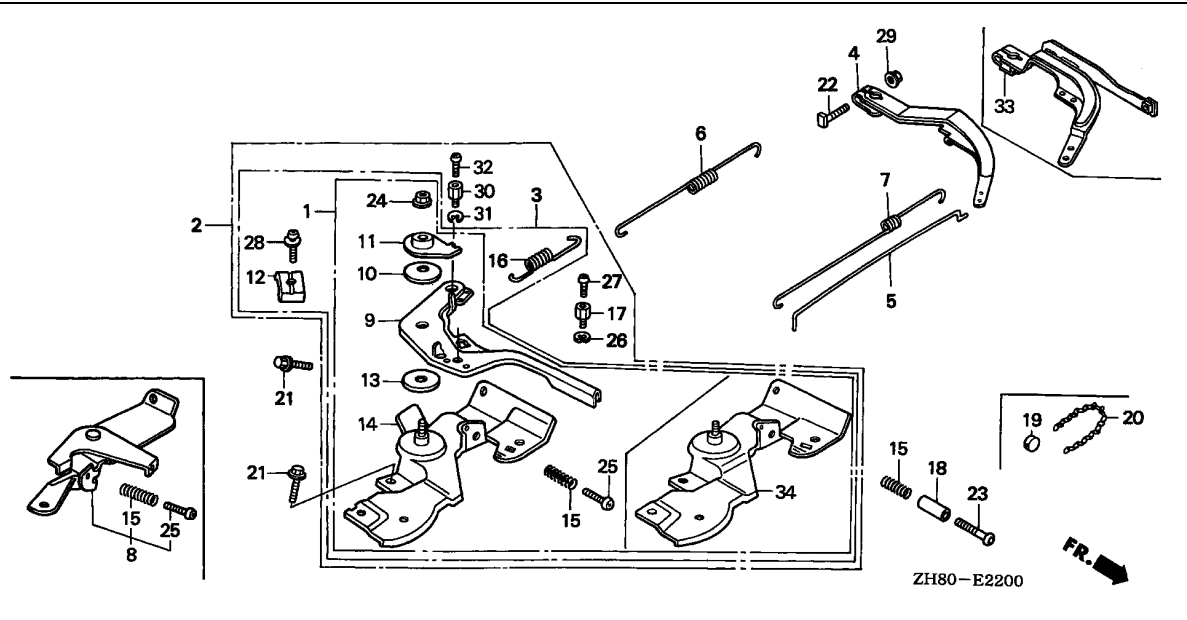

Ref. No.	Part No.	Description	Reqd. QTY				Serial No.	Parts catalogue code
			(1)	(2)	(3)	(4)		
29	94050-06000	NUT, FLANGE, 6MM	1	-	-	-	-----	AR,ARC6,BL,DS,DSP,EMA,EMA2,EN,ET,ETX,HG1,HG12,HH,HHQ4,HH26,HX HXE,HXE2,HXE8,HXQ,HXU,HX2,HX26,HX4,KR,KTA,LAX,LAX2,LD,LDB1 LDB3,LDM,LD4,LH,LHB3,LHQ4,LHW,LJ,LJC7,LJD,LJG,LJS,LMT,LSJ,LSJ4 LSS,LSS1,LSS4,LTA,LTK,LVL,LW2,LX,LXU,LX2,LX26,LX4,NJ,NJC1,NJG NSJ,NW,PH,PHM,PHU,PM,PM2,PX,PXU,PX2,QA,QAB1,QAB3,QAX,QAX2,QA2 QA26,QBC2,QBT2,QBT6,QBU2,QCB2,QCL,QD,QE,QFE4,QGR2,QGR9,QH,QHE QHP1,QHQ4,QH26,QI2,QKA4,QM,QMC6,QMC8,QMD6,QME4,QMH,QMX2,QMZ2 QNT,QNT2,QNT4,QNZ,QP,QPU,QSC2,QSC9,QS2,QT,QVL,QWA4,QWM2,QWX2 QWX3,QX,QXB,QXB1,QXC,QXC6,QXC9,QXE,QXE2,QXE4,QXE6,QXE8,QXF QXF2,QXM1,QXQ,QXS,QXS2,QXU,QXW,QXW2,QX2,QX22,QX26,QX4,QX7,RAC RD,RD4,REX4,RFR,RFR2,RH,RHA,RHA2,RHQ4,RH2,RH26,RMB4,RMD,RMG2 RNG,RSK,RSS1,RTB2,RX,RXE,RXE2,RXE4,RXU,RX4,SAC,SAD2,SCJ,SD SDB1,SDB3,SDN,SDS,SDS2,SDS3,SD16,SD4,SE,SEE,SG24,SH,SHM,SHQ4 SHRY,SHR4,SJ,SJC,SJC1,SJC5,SJG,SMB4,SMC7,SMC9,SMJ,SMJ1,SMW2 SMX4,SM11,SM12,SM14,SNX,SNX1,SSK1,SSK2,SSX2,ST,STA,STM,STP,STQ SWG4,SWX,SWX2,SWX4,SW2,SX,SXB,SXE,SXE4,SXS4,SXU,SX4, SX7,S1CY TCS2,TH,THU,TX,TC9,TXU,TX2,TX26,TX4,UH,UX,UXU,VA,VA2,VEBM VEB2,VED,VED1,VED2,VED3,VED5,VED6,VED7,VEN2,VES,VGE4,VG24,VH VHA7,VHH4,VHQ4,VMB3,VMS4,VMS7,VMT,VPM4,VPM5,VPM7,VPR4,VPR7,VS VSB1,VSD,VSD1,VSD7,VSG,VSW,VSX,VSX1,VSX3,VS1,VS17,VS3,VS4,VTD VTD1,VTE2,VTU1,VTX,VTX1,VVA,VVA2,VW12,VX,VXD,VXD1,VXE,VXE4 VXE6,VXE7,VXG,VXM,VXU,VXU1,VXW,VXW1,VXW2,VX2,VX26,VX4,WDA6,WJP WKD6,WKT2,WKT4,WKT6,WMB0,WME2,WME4,WMT
30	16594-883-010	HOLDER, WIRE	1	-	-	1	-----	QNT,QNT2,QSC9,SMX4 RSS1 SM11,SM12,SM14 SHRY

Ref. No.	Part No.	Description	Reqd. QTY				Serial No.	Parts catalogue code
			(1)	(2)	(3)	(4)		
31	90605-230-000	CIRCLIP, 5MM	1	-	-	-	QNT,QNT2,QSC9,SMX4	
			1	-	-	-	6196200 RSS1	
			1	-	-	-	6276085 SM11,SM12,SM14	
			1	-	-	-	6481741 SHRY	
32	93500-04006-0H	SCREW, PAN, 4X6	1	-	-	-	QSC9,SMX4	
			1	-	-	-	6196200 RSS1	
			1	-	-	-	6276085 SM11,SM12,SM14	
			1	-	-	-	6481741 SHRY	
33	93500-06006-0H	SCREW, PAN, 6X6	1	-	-	-	QNT,QNT2	
			1	-	-	-	SJC5,SMJ,SMJ1	
34	16550-ZH8-U50	ARM COMP., GOVERNOR (MEIJI)	1	(1)	-	-	QZ,R1,S1,T1,VA,VHQ4,VXE,VXW,V1	
			1	(1)	-	-	3403755 5551817 L1,PH,PHU,PX,PX2,Q1,TH,THU,TX,TX2,TX4,UH,UX,VH,VX,VXE4,VXW2,VX2,VX4,WMT,W1	
16580-ZH8-851	16580-ZH8-010	BASE COMP., CONTROL	1	-	-	-	5551817 PHM,SJC1,SJC5,TX26,VA2,VXE6,VXM,VX26,WMB0	
			1	(1)	-	-	3435941 5551817 QXC,S1	
			1	-	-	-	5551817 LSS4,QNT4,QSC2,QXC6,QXC9,TXC9	
			1	(1)	-	-	3435941 L1,Q1,R1,T1,V1,W1	
16580-ZH8-020	16580-ZH8-020	BASE COMP., CONTROL	1	(1)	-	-	5551818 6196199 L1,PH,PHM,PHU,PX,Q1,TH,THU,TX26,TX4,UH,UX,VH,VXE4,VXE6,VXM,VX26,VX4,WMB0,W1	
			1	-	-	-	6196199 PXU,TXU,UXU,WME4	
			1	-	-	-	6331304 TCS2	
			1	-	-	1	5551818 6331304 PX2,SJC1,SJC5,TX,TX2,VA2,VX,VXW2,VX2,WMT	
16580-ZH8-811	16580-ZH8-811	BASE COMP., CONTROL (REMOTE)	1	(1)	-	-	2000118 VSDP,VXP	
			1	(1)	-	-	3393322 LJD,LTk,STA,V1	
			1	(1)	-	-	3393322 5551817 DS,DSP,LJ,LJG,LJS,LMT,LSS,L1,Q1,RMD,R1,SCJ,SJ,SJG,SMJ,SMJ1,SNX	
			1	-	-	1	5551817 SSK1,ST,STP,STQ,S1,WJP,W1	
16580-ZH8-852	16580-ZH8-852	BASE COMP., CONTROL (CYCLONE)	1	-	-	-	5551817 KR,LJC7,LSJ,NJ,NJG,NSJ,QXM1,RNG,SJC,SNX1,STM,SXP1	
			1	-	-	-	LSS1	
			1	(1)	-	-	5551818 6196199 LSS4,QNT4,QXC6,S1	
			1	-	-	-	6331304 QSC9	
16580-ZH8-030	16580-ZH8-030	BASE COMP., CONTROL	1	-	-	-	5551818 6331304 QSC2,QXC,QXC9,TXC9	
			1	(1)	-	-	6196200 L1,PH,PHM,PHU,PX,PXU,Q1,TH,THU,TXU,TX26,TX4,UH,UX,UXU,VH,VXE4,VXE6,VXM,VX26,VX4,WMB0,WME4,W1	
			1	-	1	-	VXE7,WDA6,WIH1	
			1	-	-	-	6331305 PX2,SJC1,SJC5,TCS2,TX,TX2,VA2,VX,VXW2,VX2,WMT	
16580-ZH8-812	16580-ZH8-812	BASE COMP., CONTROL (REMOTE)	1	-	-	1	2000119 VSDP,VXP	
			1	(1)	-	-	5551818 6196199 ARC6,HH,HHQ4,HH26,HXE,HXE8,HX26,HX4,KTA,LD,LDB1,LDB3,LDM,LD4	
			1	-	-	-	LH,LHB3,LHQ4,LSJ4,LW2,LX,LXU,LX26,LX4,L1,NW,PM2,QAB1,QAB3,QA26	
			1	-	-	-	6331304 QCB2,QGR9,RSS1,SHRY,SM11,SM12	
16580-ZH8-853	16580-ZH8-853	BASE COMP., CONTROL (CYCLONE)	1	-	-	-	5551818 6331304 AR,DS,DSP,HG12,HX,HX2,KR,LJ,LJC7,LJG,LJS,LMT,LSJ,LSS,LX2,NJ	
			1	(1)	-	-	6196200 NJG,NSJ,QA,QAX2,QA2,QBT2,QGR2,QMX2,QMZ2,QWM2,QWX2,QX,QXE,QXE2	
			1	-	-	-	6331305 QXF2,QXM1,QXQ,QXS2,QX2,RFR2,RH,RHA2,RH2,RMD,RMG2,RNG,RTB2,SCJ	
			1	-	-	-	5551818 2000118 SG24,SJ,SJC,SJG,SMJ,SMJ1,SMW2,SNX,SNX1,SSK1,SSX2,ST,STM,STP	
16580-ZH8-853	16580-ZH8-853	BASE COMP., CONTROL (CYCLONE)	1	-	-	1	STQ,VG24,WJP,WKT2,WME2	
			1	(1)	-	-	6196200 LSS4,QNT4,QXC6,S1	
			1	-	-	-	6331305 QSC2,QSC9,QXC,QXC9,TXC9	



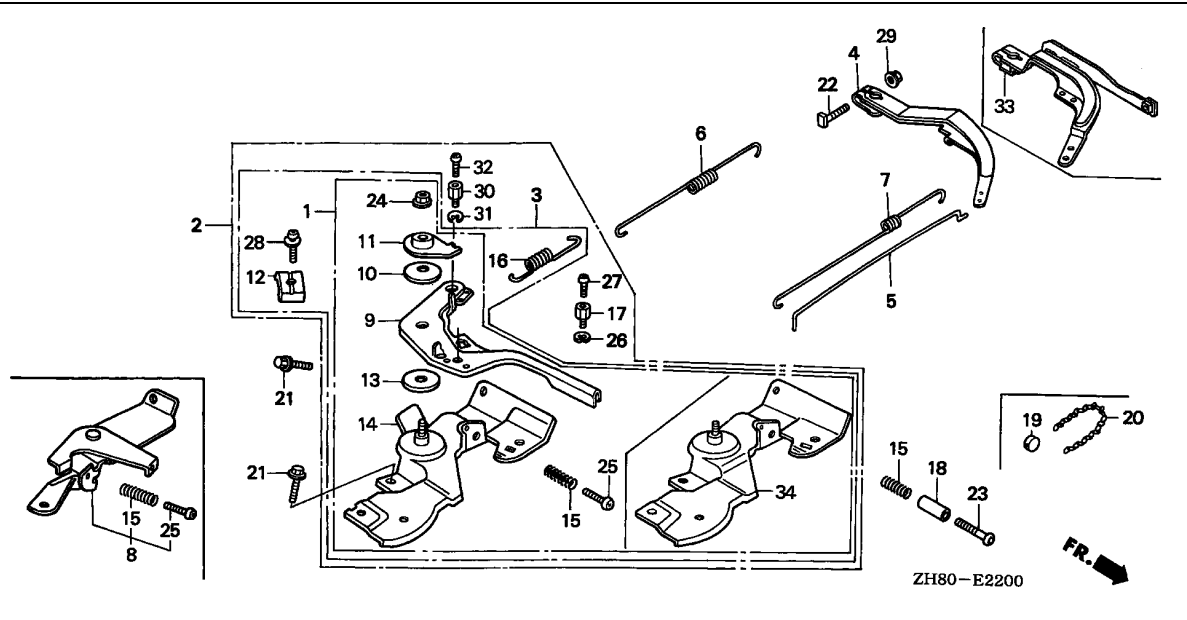

2

Ref. No.	Part No.	Description	Reqd. QTY				Serial No.	Parts catalogue code
			(1)	(2)	(3)	(4)		
34)	16580-ZH8-813	BASE COMP., CONTROL (REMOTE)	1	(1)	-	-	6196200	----- ARC6,HH,HHQ4,HH26,HXE,HXE8,HXU,HX26,HX4,KTA,LD,LDB1,LDB3,LDM LD4,LH,LHB3,LHQ4,LHW,LSJ4,LW2,LX,LXU,LX26,LX4,L1,NW,PM2,QAB1 QAB3,QA26,QBT6,QD,QE,QFE4,QH,QHE,QHP1,QHQ4,QH26,QKA4,QM,QMC6 QMC8,QMD6,QME4,QMH,QNT,QNZ,QP,QPU,QT,QWA4,QXB1,QXE4,QXE6,QXE8 QXU,QXW,QXW2,QX26,QX4,Q1,RD,RD4,REX4,RHQ4,RH26,RMB4,RSK,RX,RXE RXE4,RXU,RX4,R1,SD,SDB1,SDB3,SDN,SDS,SDS2,SDS3,SD16,SD4,SE,SEE SH,SHM,SHQ4,SHR4,SMC7,SMC9,SM14,SWG4,SX,SXB,SXE,SXE4,SXS4,SXU SX4,S1,VEBM,VM3,WKT4,W1
			1	-	1	-	-----	BL,HXE2,LVL,NJC1,QBC2,QCL,QIH1,QI2,QS2,QVL,QWX3,QX22,QX7,RXE2 SMX4,SWX2,SWX4,SX7,S1CY,UIH,WKD6,WKT6
			1	-	-	-	6331305	----- AR,DS,DSP,HG12,HX,HX2,KR,LJ,LJC7,LJG,LJS,LMT,LSJ,LSS,LX2,NJ NJG,NSJ,QA,QAX2,QA2,QBT2,QCB2,QGR2,QGR9,QMX2,QMZ2,QWM2,QWX2,QX QXE,QXE2,QXF2,QXM1,QXQ,QXS2,QX2,RFR2,RH,RHA2,RH2,RMD,RMG2,RNG RSS1,RTB2,SCJ,SG24,SHRY,SJ,SJC,SJG,SMJ,SMJ1,SMW2,SM11,SM12,SNX SNX1,SSK1,SSX2,ST,STM,STP,STQ,VG24,WJP,WKT2,WME2
			-	-	-	1	2000119	----- SXP1

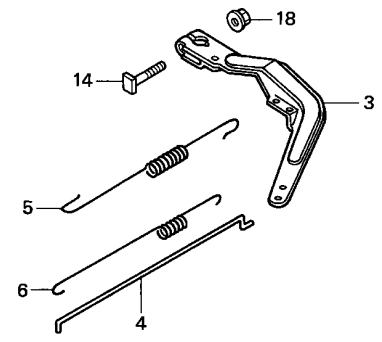
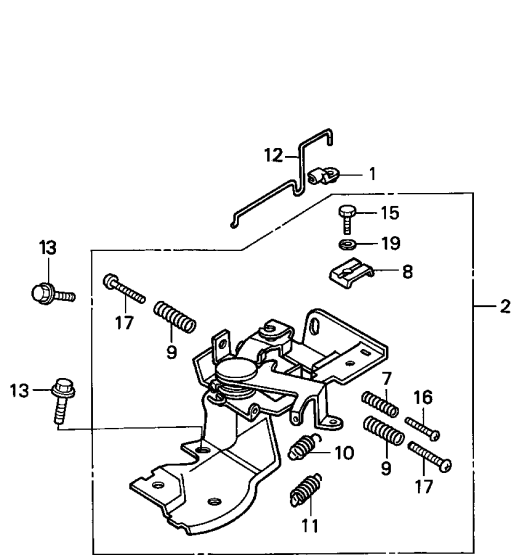

ZH80-E2201



Ref. No.	L.O.N.	(Relative ref. Number) Description	F.R.T.
2	1161D1	CONTROL, THROTTLE/GOVERNOR(A)	0.3
3	1161D0	ARM, GOVERNOR(A)	0.3
4	1161C9	ROD, GOVERNOR(A)	0.4
5	1161D4	SPRING, GOVERNOR(A)	0.3
6	1161D3	SPRING, THROTTLE RETURN(A) ..	0.4
12	8101R5	ROD, GOVERNOR CHOKE CONTROL ..	0.2

Ref. No.	Part No.	Description	Reqd. QTY				Serial No.	Parts catalogue code
			(1)	(2)	(3)	(4)		
			GX160K1					
1	16263-ZA0-000	JOINT, ROD	1	-	-	-	----- SKM	
2	16500-ZF1-H54	CONTROL ASSY.	1	-	-	-	----- SKM	
3	16551-ZE0-010	ARM, GOVERNOR	1	-	-	-	----- SKM	
4	16555-ZE1-000	ROD, GOVERNOR	1	-	-	-	----- SKM	
5	16561-ZE1-710	SPRING, GOVERNOR	1	-	-	-	----- SKM	
6	16562-ZE1-020	SPRING, THROTTLE RETURN	1	-	-	-	----- SKM	
7	16571-892-000	SPRING, CONTROL ADJUSTING	1	-	-	-	----- SKM	
8	16576-891-000	HOLDER, CABLE	1	-	-	-	----- SKM	
9	16584-883-300	SPRING, CONTROL ADJUSTING	2	-	-	-	----- SKM	
10	16592-ZE1-810	SPRING, CABLE RETURN	1	-	-	-	----- SKM	
11	16592-732-700	SPRING, CABLE RETURN	1	-	-	-	----- SKM	
12	16674-ZF1-H50	ROD, CHOKE	1	-	-	-	----- SKM	
13	90013-883-000	BOLT, FLANGE, 6X12(CT200)	2	-	-	-	----- SKM	
14	90015-ZE5-010	BOLT, GOVERNOR ARM	1	-	-	-	----- SKM	
15	92301-05016-0A	BOLT, RECESSED, 5X16	1	-	-	-	----- SKM	
16	93500-04020-0A	SCREW, PAN, 4X20	1	-	-	-	----- SKM	
17	93500-05020-0H	SCREW, PAN, 5X20	2	-	-	-	----- SKM	
18	94050-06000	NUT, FLANGE, 6MM	1	-	-	-	----- SKM	
19	94111-05800	WASHER, SPRING, 5MM	1	-	-	-	2709371 SKM	



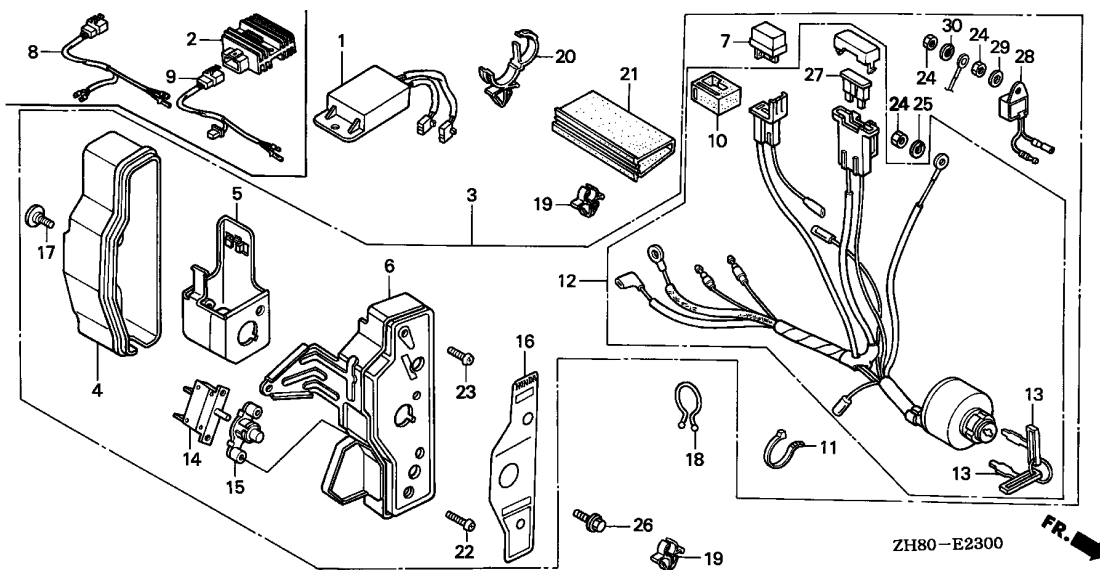

Ref. No.	L.O.N.	(Relative ref. Number) Description	F.R.T.
1		(2)	
	6131B7	RECTIFIER, REGULATOR	0.2
3	6221A2	BOX, CONTROL	0.1
6	4131F9	PANEL, CONTROL	0.2
7	6131B8	RECTIFIER, SILICON	0.1
8		(9)	
	6111E6	HARNES, REGULATOR RECTIFIER ..	0.2
12	6151E1	SWITCH, COMBINATION	0.2
14	6221D4	PROTECTOR, CIRCUIT	0.2
27	8121A7	FUSE, BLADE	0.1
28	6151A0	ALERT UNIT, OIL	0.1

2

Ref. No.	Part No.	Description	Reqd. QTY				Serial No.	Parts catalogue code
			(1)	(2)	(3)	(4)		
			GX160K1					
1	31600-KE1-010	RECTIFIER COMP., REGULATOR ..	-	(1)	-	-		
2	31600-ZE2-861	RECTIFIER ASSY., REGULATOR (10A)	1	-	-	-	LAX,LAX2,QAX2,QNZ,QSC2,QXW,QXW2,REX4	
3	31610-ZE1-812ZB	BOX ASSY., CONTROL (EXTERNAL) *R8*.....BRIGHT RED	1	-	-	-	----- QHE,SEE	
	31610-ZH8-R92ZA	BOX ASSY., CONTROL (EXP,10A) *R8*.....BRIGHT RED	1	-	-	-	----- 5372718 QXW,REX4 ----- 5380585 QSC2	
	31610-ZH8-R93ZA	*R8*.....BRIGHT RED	1	-	-	-	----- 5372719 QXW,REX4 ----- 5380586 QSC2	
	31610-ZH8-W51ZB	*R8*.....BRIGHT RED	1	-	-	-	----- 5372718 QXW2	
	31610-ZH8-W52ZB	BOX ASSY., CONTROL (EXTERNAL-10A) *R8*.....BRIGHT RED	1	-	-	-	----- 5372719 QXW2	
	31610-ZE1-013ZB	BOX ASSY., CONTROL (INTERNAL) *R8*.....BRIGHT RED	-	(1)	-	-		
4	31612-ZE2-003	CASE, CONTROL	1	-	-	-	----- QHE,QSC2,QXW,QXW2,REX4,SEE	
	31614-ZE2-003	BRACKET, CASE MOUNTING	1	-	-	-	----- QHE,QSC2,QXW,QXW2,REX4,SEE	
	31615-ZE1-003ZB	PANEL COMP., CONTROL *R8*.....BRIGHT RED	1	-	-	-	----- QHE,QSC2,QXW,QXW2,REX4,SEE	
7	31700-124-008	RECTIFIER ASSY., SILICON (SHINDENGEN)	1	-	-	-	----- QHE,SEE	

Ref. No.	Part No.	Description	Reqd. QTY				Serial No.	Parts catalogue code
			(1)	(2)	(3)	(4)		
8	32110-ZB5-G30	HARNESS ASSY., SUB WIRE	1	-	-	-	LAX,LAX2,QAX2,QNZ,QSC2,QXW2,REX4	
			1	-	-	2792842	QXW	
9	32110-ZE2-860	HARNESS ASSY., SUB WIRE	1	-	-	2792841	QXW	
10	32127-738-700	SUSPENSION, COUPLER	1	-	-	-	QHE,SEE	
			-	(1)	-	-		
11	32902-892-003	BAND	1	-	-	-	QHE,QSC2,QXW,QXW2,REX4,SEE	
			-	(1)	-	-		
12	35100-ZE1-812	SWITCH ASSY., COMBINATION ...	1	-	-	-	QHE,SEE	
			-	(1)	-	-		
	35100-ZH8-R90	SWITCH ASSY., COMBINATION (10A CHG/RCM)	1	-	-	-	QSC2,QXW,QXW2,REX4	
13	35111-880-003	KEY COMP.	2	-	-	-	QHE,QSC2,QXW,QXW2,REX4,SEE	
			-	(2)	-	-		
14	38240-VA3-900	PROTECTOR, CIRCUIT (1.0A) ...	1	-	-	-	QHE,SEE	
			-	(1)	-	-		
15	38250-ZA8-701	LENS ASSY., PROTECTOR	1	-	-	-	QHE,SEE	
			-	(1)	-	-		
16	87529-ZE2-811	PANEL, CONTROL BOX (EXTERNAL)	1	-	-	-	QHE,SEE	
			-	(1)	-	-		
	87529-ZE2-860	MARK, CONTROL BOX (EXTERNAL-REGULATOR)	1	-	-	-	QXW2	
			1	-	-	3264017	QXW	
	87529-ZH8-W40	MARK, CONTROL BOX (ENGLISH) -	1	-	-	-	QSC2,REX4	
			1	-	-	3264018	QXW	
	87529-ZE2-010	PANEL, CONTROL BOX (INTERNAL)	-	(1)	-	-	H1,Q1,R1,S1,T1,U1,V1,W1	
			-	(1)	-	8691291	L1	
	87529-ZE2-020	-	(1)	-	8691292	L1	
17	90380-MA6-010	SCREW, SPECIAL, 6X12	1	-	-	-	QHE,QSC2,QXW,QXW2,REX4,SEE	
			-	(1)	-	-		
18	90630-751-000	CLIP, PURSE LOCK	1	-	-	-	QHE,QSC2,QXW,QXW2,REX4,SEE	
			-	(1)	-	-		
19	90682-ZE1-000	CLIP, CORD	2	-	-	-	QHE,QSC2,QXW,QXW2,REX4,SEE	
			-	(2)	-	-		
20	90690-SA0-003	STRAP, WIRE HARNESS, 25MM (BLACK)	1	-	-	-	QHE,QSC2,QXW,QXW2,REX4,SEE	
			-	(1)	-	-		
21	91406-ZE2-003	TUBE, FASTENER, 30MM	1	-	-	-	QHE,QSC2,QXW,QXW2,REX4,SEE	
			-	(1)	-	-		
22	93500-03012-0H	SCREW, PAN, 3X12	2	-	-	-	QHE,SEE	
			-	(2)	-	-		
23	93500-04012-0H	SCREW, PAN, 4X12	1	-	-	-	QHE,QSC2,QXW,QXW2,REX4,SEE	
			-	(1)	-	-		
24	94001-04390-0S	NUT, HEX., 4MM	1	-	-	-	QHE,SEE	
			1	-	-	5372718	QXW,QXW2,REX4	
			1	-	-	5380585	QSC2	
			-	(1)	-	-		
			2	-	-	5372719	QXW,QXW2,REX4	
			2	-	-	5380586	QSC2	
25	94111-04800	WASHER, SPRING, 4MM	1	-	-	-	QSC2,QXW,QXW2,REX4	
26	95701-06010-00	BOLT, FLANGE, 6X10	1	-	-	-	QHE,QSC2,QXW,QXW2,REX4,SEE	
			-	(1)	-	-		
	90015-883-000	BOLT, FLANGE, 6X28	-	(2)	-	-		



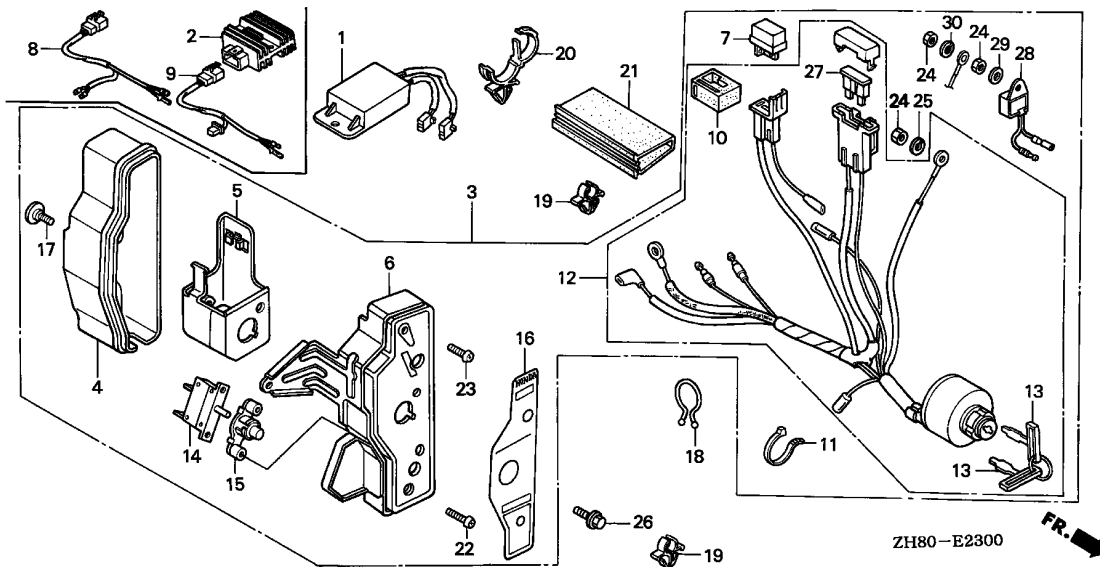

ZH80-E2300



2

Ref. No.	Part No.	Description	Reqd. QTY				Serial No.	Parts catalogue code
			(1)	(2)	(3)	(4)		
27	98200-30500	FUSE, BLADE (5A)	1	-	-	-	-----	QHE,SEE
	98200-31500	FUSE, BLADE (15A)	-	(1)	-	-	-----	QSC2,QXW,QXW2,REX4
28	34150-ZH7-003	ALERT UNIT, OIL	1	-	-	5372719	-----	QXW,QXW2,REX4
			1	-	-	5380586	-----	QSC2
29	94101-04800	WASHER, PLAIN, 4MM	1	-	-	5372719	-----	QXW,QXW2,REX4
			1	-	-	5380586	-----	QSC2
30	94111-04800	WASHER, SPRING, 4MM	1	-	-	5372719	-----	QXW,QXW2,REX4

E-23-1

CONTROL BOX(2)

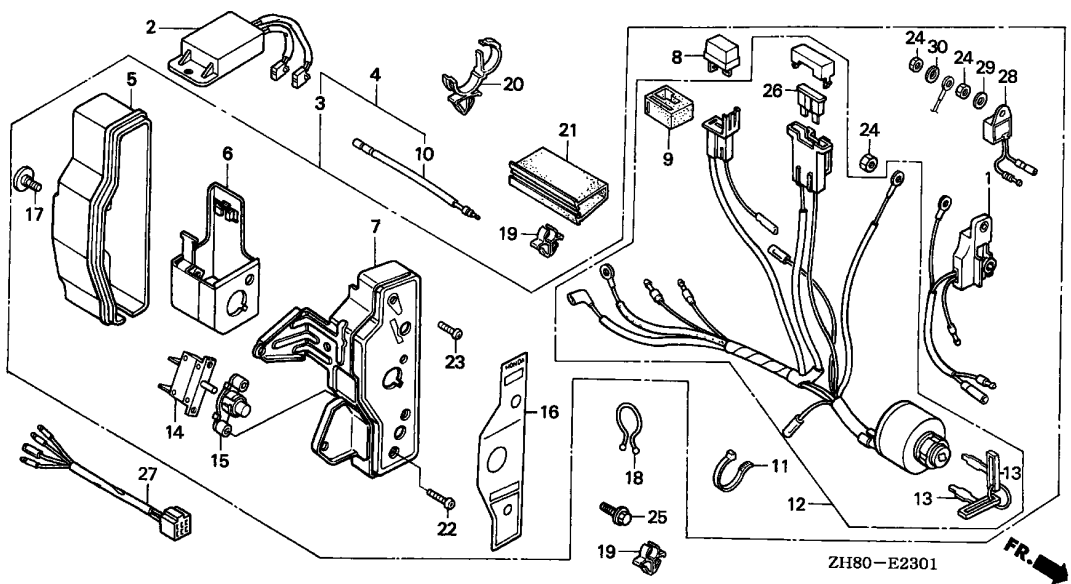

Ref. No.	L.O.N.	(Relative ref. Number) Description	F.R.T.
1		(28)	
	6151F5	ALERT UNIT, OIL(A)	0.2
2	6131B7	RECTIFIER, REGULATOR	0.2
4		(10)	
	6221A2	BOX, CONTROL	0.1
7	4131F9	PANEL, CONTROL	0.2
8	6131B8	RECTIFIER, SILICON	0.1
12	6151E1	SWITCH, COMBINATION	0.2
14	6221D4	PROTECTOR, CIRCUIT	0.2
26	8121A7	FUSE, BLADE	0.1
27	6111D3	HARNES, SUB WIRE	0.1

Ref. No.	Part No.	Description	Reqd. QTY				Serial No.	Parts catalogue code
			(1)	(2)	(3)	(4)		
			GX160K1					
1	15520-ZE1-822	ALERT UNIT, OIL	1	-	-	-	2468252 QXE,RXE,SXE,VXE	
2	31600-KE1-010	RECTIFIER COMP., REGULATOR ..	-	(1)	-	-	2468252	
3	31610-ZE1-833ZB	BOX ASSY., CONTROL (EXP-ALERT)	-	(1)	-	-		
		R8.....BRIGHT RED	1	-	-	-	2468252 QXE,RXE,SXE,VXE	
		31610-ZE1-823ZB BOX ASSY., CONTROL	-	(1)	-	-	2468252	
		(INTERNAL/ALERT)						
		R8.....BRIGHT RED	-	(1)	-	-	2468252	
		R8.....BRIGHT RED	-	(1)	-	-	2468253	
4	31610-ZE1-834ZA	BOX ASSY., CONTROL (EXP-ALERT)	1	-	-	-	5380585 QXE2	
		NH1.....BLACK	1	-	-	-	2468253 VXE	
		31610-ZE1-834ZB *R8*.....BRIGHT RED	1	-	-	-	5372718 HXE,QXE6,VXE6	
			1	-	-	-	5380585 QXE2	
			1	-	-	-	2468253 5372718 QXE,RXE,SXE	
		31610-ZK8-W41ZA BOX ASSY., CONTROL	-	(1)	-	-	2468253	
		(EXTERNAL-ALERT)						
		R8.....BRIGHT RED	1	-	-	-	5372718 QKA4,QXE4,RXE4,SXE4,VXE4	
		31610-ZE1-835ZA BOX ASSY., CONTROL (EXP-ALERT)	1	-	-	-		
		NH1.....BLACK	1	-	-	-	5380586 QXE2	
		31610-ZE1-835ZB *R8*.....BRIGHT RED	1	-	-	-	5372719 HXE,VXE6	
			1	-	-	-	8373305 HXE2,HXE8,QXE8,RXE2	
			1	-	-	-	8373305 QXE,QXE6,RXE,SXE	
			1	-	-	-	5380586 8373305 QXE2	



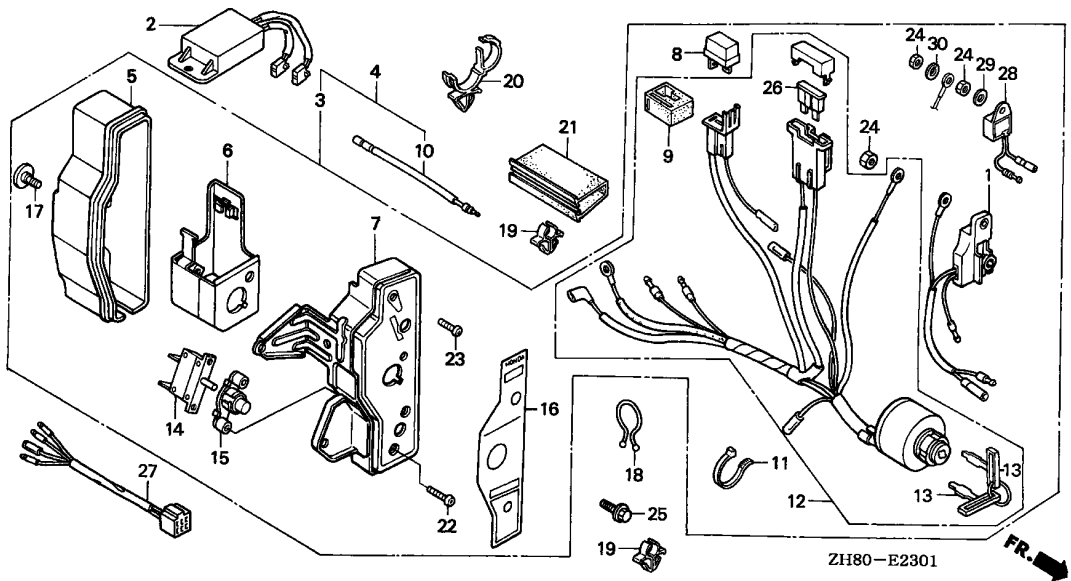

Ref. No.	Part No.	Description	Reqd. QTY				Serial No.	Parts catalogue code
			(1)	(2)	(3)	(4)		
(4)	31610-ZK8-W42ZA	BOX ASSY., CONTROL (EXTERNAL-ALERT)						
	R8BRIGHT RED	1	-	-	-	----- VXE7	
	31610-ZE1-835ZG	BOX ASSY., CONTROL (EXP-ALERT)	1	-	-	-	5372719 -----	QKA4,QXE4,RXE4,SXE4,VXE4
	R280POWER RED	1	-	-	-	8373306 -----	HXE2,HXE8,QXE,QXE2,QXE6,QXE8,RXE,RXE2,SXE
5	31612-ZE2-003	CASE, CONTROL	1	-	-	-	-----	HXE,HXE2,HXE8,QKA4,QXE,QXE2,QXE4,QXE6,QXE8,RXE,RXE2,RXE4,SXE
				(1)	-	-		SXE4,VXE,VXE4,VXE6,VXE7
6	31614-ZE2-003	BRACKET, CASE MOUNTING	1	-	-	-	-----	HXE,HXE2,HXE8,QKA4,QXE,QXE2,QXE4,QXE6,QXE8,RXE,RXE2,RXE4,SXE
				(1)	-	-		SXE4,VXE,VXE4,VXE6,VXE7
7	31615-ZE1-003ZA	PANEL COMP., CONTROL	1	-	-	-	-----	QXE2
	NH1BLACK	1	(1)	-	-	-----	HXE,HXE8,H1,Q1,R1,S1,T1,U1,VXE,VXE6,V1,W1
	31615-ZE1-003ZB	*R8*.....BRIGHT RED	1	(1)	-	-	8394660 -----	HXE2,L1,QKA4,QXE,QXE2,QXE4,QXE6,QXE8,RXE,RXE2,RXE4,SXE,SXE4
				(1)	-	-		VXE4,VXE7
	31615-ZE1-003ZG	*R280*.....POWER RED	1	(1)	-	-	8394661 -----	HXE2,L1,QKA4,QXE,QXE2,QXE4,QXE6,QXE8,RXE,RXE2,RXE4,SXE,SXE4
				(1)	-	-		VXE4,VXE7
8	31700-124-008	RECTIFIER ASSY., SILICON (SHINDENGEN)	1	-	-	-	-----	HXE,HXE2,HXE8,QKA4,QXE,QXE2,QXE4,QXE6,QXE8,RXE,RXE2,RXE4,SXE
				(1)	-	-		SXE4,VXE,VXE4,VXE6,VXE7
9	32127-738-700	SUSPENSION, COUPLER	1	-	-	-	-----	HXE,HXE2,HXE8,QKA4,QXE,QXE2,QXE4,QXE6,QXE8,RXE,RXE2,RXE4,SXE
				(1)	-	-		SXE4,VXE,VXE4,VXE6,VXE7

Ref. No.	Part No.	Description	Reqd. QTY				Serial No.	Parts catalogue code
			(1)	GX160K1 (2)	(3)	(4)		
10	32197-ZE1-003	SUB HARNESS	1	-	-	-	HXE,HXE2,HXE8,QKA4,QXE4,QXE6,QXE8,RXE2,RXE4,SXE4,VXE4,VXE6 VXE7	
			1	-	-	2468253	QXE,RXE,SXE,VXE	
			-	(1)	-	2468253		
11	32902-892-003	BAND	1	-	-	-	HXE,HXE2,HXE8,QKA4,QXE,QXE2,QXE4,QXE6,QXE8,RXE,RXE2,RXE4,SXE SXE4,VXE,VXE4,VXE6,VXE7	
12	35100-ZE1-812	SWITCH ASSY., COMBINATION ...	-	(1)	-	-		
			1	-	-	-	HXE,HXE2,HXE8,QKA4,QXE,QXE2,QXE4,QXE6,QXE8,RXE,RXE2,RXE4,SXE SXE4,VXE,VXE4,VXE6,VXE7	
13	35111-880-003	KEY COMP.	-	(1)	-	-		
			2	-	-	-	HXE,HXE2,HXE8,QKA4,QXE,QXE2,QXE4,QXE6,QXE8,RXE,RXE2,RXE4,SXE SXE4,VXE,VXE4,VXE6,VXE7	
14	38240-VA3-900	PROTECTOR, CIRCUIT (1.0A) ...	-	(2)	-	-		
			1	-	-	-	HXE,HXE2,HXE8,QKA4,QXE,QXE2,QXE4,QXE6,QXE8,RXE,RXE2,RXE4,SXE SXE4,VXE,VXE4,VXE6,VXE7	
15	38250-ZA8-701	LENS ASSY., PROTECTOR	-	(1)	-	-		
			1	-	-	-	HXE,HXE2,HXE8,QKA4,QXE,QXE2,QXE4,QXE6,QXE8,RXE,RXE2,RXE4,SXE SXE4,VXE,VXE4,VXE6,VXE7	
			-	(1)	-	-		
16	87529-ZE2-831	PANEL, CONTROL BOX (EXTERNAL-ALERT)	1	-	-	-	2468252 QXE,RXE,SXE,VXE	
			-	(1)	-	-	2468252	
	87529-ZH9-W40	MARK, CONTROL BOX (ENGLISH) -	1	-	-	-	QKA4,QXE4,RXE4,SXE4,VXE4,VXE7	
	87529-ZE2-010	PANEL, CONTROL BOX (INTERNAL)	-	(1)	-	-	H1,Q1,R1,S1,T1,U1,V1,W1	
			-	(1)	-	2468253	8691291 L1	
	87529-ZE2-811	PANEL, CONTROL BOX (EXTERNAL)	1	-	-	-	HXE,HXE2,HXE8,QXE2,QXE6,QXE8,RXE2,VXE6	
			1	-	-	2468253	QXE,RXE,SXE,VXE	
			-	(1)	-	2468253		
	87529-ZE2-821	PANEL, CONTROL BOX (INTERNAL-ALERT)	-	(1)	-	-	2468252	
	87529-ZE2-020	PANEL, CONTROL BOX (INTERNAL)	-	(1)	-	8691292	L1	
17	90380-MA6-010	SCREW, SPECIAL, 6X12	1	-	-	-	HXE,HXE2,HXE8,QKA4,QXE,QXE2,QXE4,QXE6,QXE8,RXE,RXE2,RXE4,SXE SXE4,VXE,VXE4,VXE6,VXE7	
			-	(1)	-	-		
18	90630-751-000	CLIP, PURSE LOCK	1	-	-	-	HXE,HXE2,HXE8,QKA4,QXE,QXE2,QXE4,QXE6,QXE8,RXE,RXE2,RXE4,SXE SXE4,VXE,VXE4,VXE6,VXE7	
			-	(1)	-	-		
19	90682-ZE1-000	CLIP, CORD	2	-	-	-	HXE,HXE2,HXE8,QKA4,QXE,QXE2,QXE4,QXE6,QXE8,RXE,RXE2,RXE4,SXE SXE4,VXE,VXE4,VXE6,VXE7	
			-	(2)	-	-		
20	90690-SAO-003	STRAP, WIRE HARNESS, 25MM (BLACK)	1	-	-	-	HXE,HXE2,HXE8,QKA4,QXE,QXE2,QXE4,QXE6,QXE8,RXE,RXE2,RXE4,SXE SXE4,VXE,VXE4,VXE6,VXE7	
			-	(1)	-	-		
21	91406-ZE2-003	TUBE, FASTENER, 30MM	1	-	-	-	HXE,HXE2,HXE8,QKA4,QXE,QXE2,QXE4,QXE6,QXE8,RXE,RXE2,RXE4,SXE SXE4,VXE,VXE4,VXE6,VXE7	
			-	(1)	-	-		
22	93500-03012-OH	SCREW, PAN, 3X12	2	-	-	-	HXE,HXE2,HXE8,QKA4,QXE,QXE2,QXE4,QXE6,QXE8,RXE,RXE2,RXE4,SXE SXE4,VXE,VXE4,VXE6,VXE7	
			-	(2)	-	-		
23	93500-04012-OH	SCREW, PAN, 4X12	1	-	-	-	HXE,HXE2,HXE8,QKA4,QXE,QXE2,QXE4,QXE6,QXE8,RXE,RXE2,RXE4,SXE SXE4,VXE,VXE4,VXE6,VXE7	
			-	(1)	-	-		



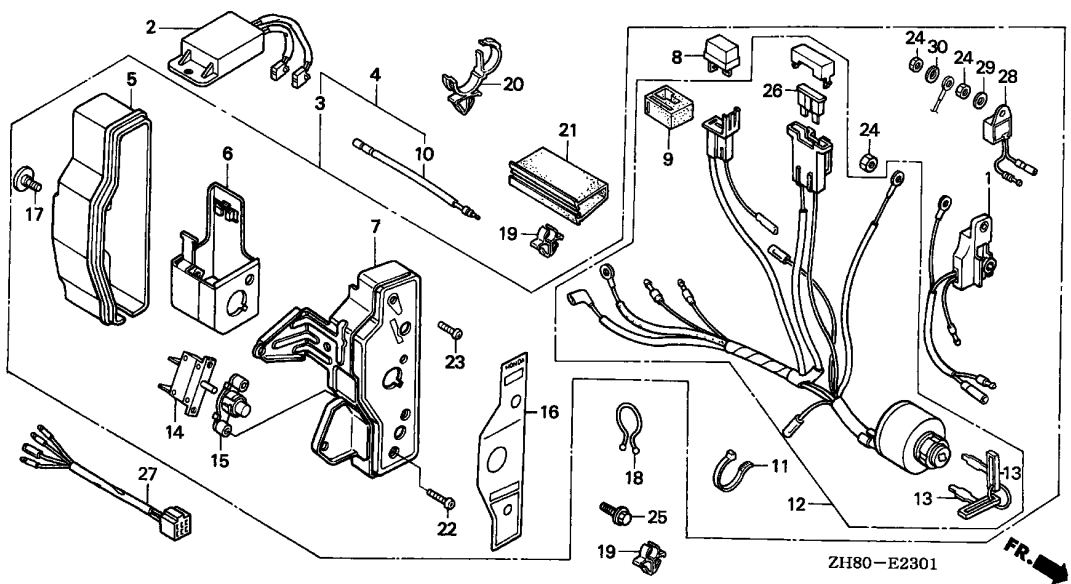

2

Ref. No.	Part No.	Description	Reqd. QTY				Serial No.	Parts catalogue code
			(1)	(2)	(3)	(4)		
24	94001-04390-0S	NUT, HEX., 4MM	1	-	-	-	VXE	
			1	-	-	-	5372718	HXE,QKA4,QXE4,QXE6,RXE,RXE4,SXE,SXE4,VXE4,VXE6
			1	-	-	-	5380585	QXE,QXE2
			-	(1)	-	-		
			2	-	-	-	HXE2,HXE8,QXE8,RXE2,VXE7	
			2	-	-	-	5372719	HXE,QKA4,QXE4,QXE6,RXE,RXE4,SXE,SXE4,VXE4,VXE6
			2	-	-	-	5380586	QXE,QXE2
25	95701-06010-00	BOLT, FLANGE, 6X10	1	-	-	-	HXE,HXE2,HXE8,QKA4,QXE,QXE2,QXE4,QXE6,QXE8,RXE,RXE2,RXE4,SXE4,VXE,VXE4,VXE6,VXE7	
			-	(1)	-	-		
	90015-883-000	BOLT, FLANGE, 6X28	-	(2)	-	-		
26	98200-30500	FUSE, BLADE (5A)	1	-	-	-	HXE,HXE2,HXE8,QKA4,QXE,QXE2,QXE4,QXE6,QXE8,RXE,RXE2,RXE4,SXE4,VXE,VXE4,VXE6,VXE7	
			-	(1)	-	-		
27	32110-ZH8-W00	HARNESS ASSY., SUB WIRE	-	(1)	-	-		
28	34150-ZH7-003	ALERT UNIT, OIL	1	-	-	-	HXE2,HXE8,QXE8,RXE2,VXE7	
			1	-	-	-	5372719	HXE,QKA4,QXE,QXE4,QXE6,RXE,RXE4,SXE,SXE4,VXE4,VXE6
			1	-	-	-	5380586	QXE2
29	94101-04800	WASHER, PLAIN, 4MM	1	-	-	-	HXE2,HXE8,QXE8,RXE2,VXE7	
			1	-	-	-	5372719	HXE,QKA4,QXE,QXE4,QXE6,RXE,RXE4,SXE,SXE4,VXE4,VXE6
			1	-	-	-	5380586	QXE2
30	94111-04800	WASHER, SPRING, 4MM	1	-	-	-	HXE2,HXE8,QXE8,RXE2,VXE7	
			1	-	-	-	5372719	HXE,QKA4,QXE,QXE4,QXE6,RXE,RXE4,SXE,SXE4,VXE4,VXE6
			1	-	-	-	5380586	QXE2

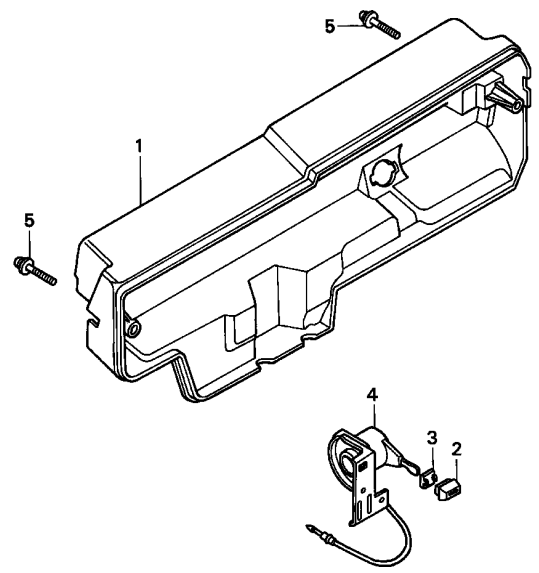

ZH80-E2302

Ref. No.	L.O.N.	(Relative ref. Number) Description	F.R.T.
1	6221A4	CASE, ENGINE CONTROL	0.2
4	6151B9	SWITCH, ENGINE	0.2

Ref. No.	Part No.	Description	Reqd. QTY				Serial No.	Parts catalogue code
			(1)	(2)	(3)	(4)		
			GX160K1					
1	31425-ZB2-000ZA	CASE, CONTROL						
		R8.....BRIGHT RED	1	-	-	-	3477005	VED2
2	32343-892-003	KNOB, COCK LEVER	1	-	-	-	3477005	VED3
			1	-	-	-	3477005	VED2
3	36106-892-003	BUSH, CONTROL KNOB	1	-	-	-	3477005	VED3
			1	-	-	-	3477005	VED2
4	36110-ZB2-003	SWITCH ASSY., ENGINE	1	-	-	-	3477005	VED3
			1	-	-	-	3477005	VED2
5	93891-06040-00	SCREW-WASHER, 6X40	2	-	-	-	2535074	3477005 VED2



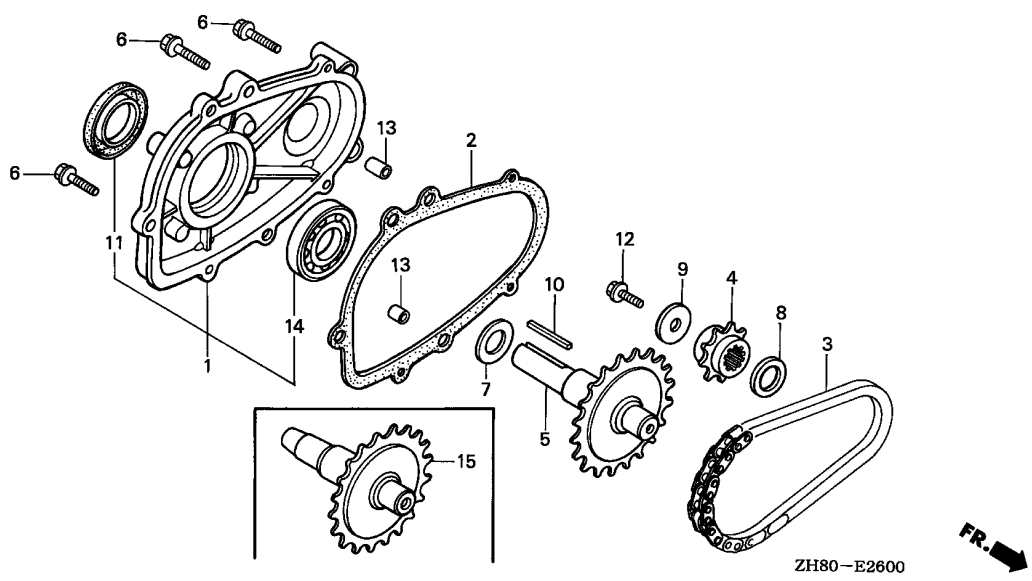

Ref. No.	L.O.N.	(Relative ref. Number) Description	F.R.T.
1		(2)	
1101B2		COVER, CHAIN CASE AND/OR PACKING, CHAIN CASE COVER ...	0.2
3	2141M1	CHAIN, POWER TAKE OFF DRIVE(A)	0.3
4	2141J8	SPROCKET, DRIVE	0.3
5		(15)	
	2141H4	SHAFT, POWER TAKE OFF	0.3
11	2141F2	OIL SEAL, POWER TAKE OFF SHAFT	0.2
14	2141A8	BEARING, POWER TAKE OFF SHAFT	0.3



Ref. No.	Part No.	Description	Reqd. QTY				Serial No.	Parts catalogue code
			(1)	GX160K1 (2)	(3)	(4)		
1	11500-ZE1-610	COVER ASSY., CHAIN CASE	1	1	-	-	8574667	LD,LH,LHB3,LHQ4,LJ,LJC7,LJG,LJS,LSJ4,LVL,LW2,LX,LXU,LX2,LX26 LX4,L1
			1	-	-	-		DS,DSP,LAX,LAX2,LDB1,LDB3,LDM,LD4,LHW,LJD,LMT,LSJ,LSS,LSS1 LSS4,LTA, LTK
	11500-ZE1-611	1	1	-	-	8574668	LD,LH,LHB3,LHQ4,LJ,LJC7,LJG,LJS,LSJ4,LVL,LW2,LX,LXU,LX2,LX26 LX4,L1
2	11521-ZE1-610	PACKING, CHAIN CASE	1	-	-	-	2630823	DS,DSP,LJ,LJS,LMT,LTA,LTK,LW2
			-	(1)	-	-		L1
	11521-ZH8-800	PACKING, CHAIN CASE COVER ...	1	(1)	-	-		LAX,LAX2,LD,LDB1,LDB3,LDM,LD4,LH,LHB3,LHQ4,LHW,LJC7,LJD,LJG LSJ,LSJ4,LSS,LSS1,LSS4,LVL,LX,LXU,LX2,LX26,LX4,L1
3	14411-ZE1-611	CHAIN, P.T.O. DRIVE (DID317FM2-34LE)	1	1	-	-	2630824	DS,DSP,LJ,LJS,LMT,LTA,LTK,LW2
			1	-	-	-		DS,DSP,LAX,LAX2,LD,LDB1,LDB3,LDM,LD4,LH,LHQ4,LHW,LJ,LJC7,LJD LJG,LJS,LMT,LSJ,LSJ4,LSS,LSS1,LSS4,LTK,LX,LXU,LX2,LX26,LX4,L1
	14411-ZF1-611	1	-	-	-	6197735	LHB3
			1	-	-	-		LTA,LVL,LW2
4	23110-ZE1-610	SPROCKET, DRIVE (13T)	1	1	-	-	6197736	LHB3
			1	-	-	-		DS,DSP,LAX,LAX2,LD,LDB1,LDB3,LDM,LD4,LH,LHB3,LHQ4,LHW,LJ,LJC7 LJG,LJG,LJS,LMT,LSJ,LSJ4,LSS,LSS1,LSS4,LTA,LTK,LVL,LW2,LX,LXU LX2,LX26,LX4,L1
5	23710-ZE1-613	SHAFT, P.T.O. (26T)	1	1	-	-		LAX,LAX2,LD,LDB1,LDB3,LDM,LD4,LH,LHB3,LHQ4,LHW,LJ,LJC7,LJD,LJG LJS,LMT,LSJ,LSJ4,LSS,LSS1,LSS4,LTA,LTK,LVL,LW2,LX,LXU,LX2,LX26 LX4,L1
6	90015-883-000	BOLT, FLANGE, 6X28	5	5	-	-		DS,DSP,LAX,LAX2,LD,LDB1,LDB3,LDM,LD4,LH,LHB3,LHQ4,LHW,LJ,LJC7 LJG,LJG,LJS,LMT,LSJ,LSJ4,LSS,LSS1,LSS4,LTA,LTK,LVL,LW2,LX,LXU LX2,LX26,LX4,L1

Ref. No.	Part No.	Description	Reqd. QTY				Serial No.	Parts catalogue code
			(1)	GX160K1 (2)	(3)	(4)		
7	90456-ZE1-000	SPRING, THRUST	1	1	-	-	----- DS,DSP,LAX,LAX2,LD,LDB1,LDB3,LDM,LD4,LH,LHB3,LHQ4,LHW,LJ,LJC7 LJD,LJG,LJS,LMT,LSJ,LSJ4,LSS,LSS1,LSS4,LTA,LTk,LVL,LW2,LX,LXU LX2,LX26,LX4,L1	
8	90470-ZE1-000	SPACER, 20MM	1	1	-	-	----- DS,DSP,LAX,LAX2,LD,LDB1,LDB3,LDM,LD4,LH,LHB3,LHQ4,LHW,LJ,LJC7 LJD,LJG,LJS,LMT,LSJ,LSJ4,LSS,LSS1,LSS4,LTA,LTk,LVL,LW2,LX,LXU LX2,LX26,LX4,L1	
9	90471-ZE1-610	WASHER, 8MM	1	1	-	-	----- DS,DSP,LAX,LAX2,LD,LDB1,LDB3,LDM,LD4,LH,LHB3,LHQ4,LHW,LJ,LJC7 LJD,LJG,LJS,LMT,LSJ,LSJ4,LSS,LSS1,LSS4,LTA,LTk,LVL,LW2,LX,LXU LX2,LX26,LX4,L1	
10	90741-883-810	KEY, 5X5X33(YELLOW)	1	(1)	-	-	----- LAX,LAX2,LD,LDB1,LDB3,LDM,LD4,LH,LHB3,LHQ4,LJ,LJC7,LJD,LJG,LJS LMT,LSJ,LSJ4,LSS,LSS1,LSS4,LTA,LTk,LVL,LW2,LX,LXU,LX2,LX26,LX4 L1	
11	91202-883-005	OIL SEAL, 25X41X6	1	1	-	-	----- 8574667 LD,LH,LHB3,LHQ4,LJ,LJC7,LJG,LJS,LSJ4,LVL,LW2,LX,LXU,LX2,LX26 LX4,L1	
			1	-	-	-	----- DS,DSP,LAX,LAX2,LDB1,LDB3,LDM,LD4,LHW,LJD,LMT,LSJ,LSS,LSS1 LSS4,LTA,LTk	
	91201-Z0T-801	1	1	-	-	----- 8574668 LD,LH,LHB3,LHQ4,LJ,LJC7,LJG,LJS,LSJ4,LVL,LW2,LX,LXU,LX2,LX26 LX4,L1	
12	92000-08025-0A	BOLT, HEX., 8X25	1	1	-	-	----- DS,DSP,LD,LH,LJ,LJS,LTA,LW2,LX,LXU,L1	
	92101-08025-0A	1	-	-	-	----- LAX,LAX2,LDB1,LDB3,LDM,LD4,LHB3,LHQ4,LHW,LJC7,LJD,LJG,LMT,LSJ LSJ4,LSS,LSS1,LSS4,LTk,LVL,LX2,LX26,LX4	
13	94301-08140	DOWEL PIN, 8X14	2	2	-	-	----- DS,DSP,LAX,LAX2,LD,LDB1,LDB3,LDM,LD4,LH,LHB3,LHQ4,LHW,LJ,LJC7 LJD,LJG,LJS,LMT,LSJ,LSJ4,LSS,LSS1,LSS4,LTA,LTk,LVL,LW2,LX,LXU LX2,LX26,LX4,L1	
14	96100-62050-00	BEARING, RADIAL BALL, 6205 ..	1	1	-	-	----- DS,DSP,LAX,LAX2,LD,LDB1,LDB3,LDM,LD4,LH,LHB3,LHQ4,LHW,LJ,LJC7 LJD,LJG,LJS,LMT,LSJ,LSJ4,LSS,LSS1,LSS4,LTA,LTk,LVL,LW2,LX,LXU LX2,LX26,LX4,L1	
15	23710-ZE1-913	SHAFT, P.T.O.	1	-	-	-	----- 2268263 DS	
	23710-ZE1-903	1	-	-	-	----- 2268263 DSP	



E-26-1

REDUCTION(2)

2-G 9

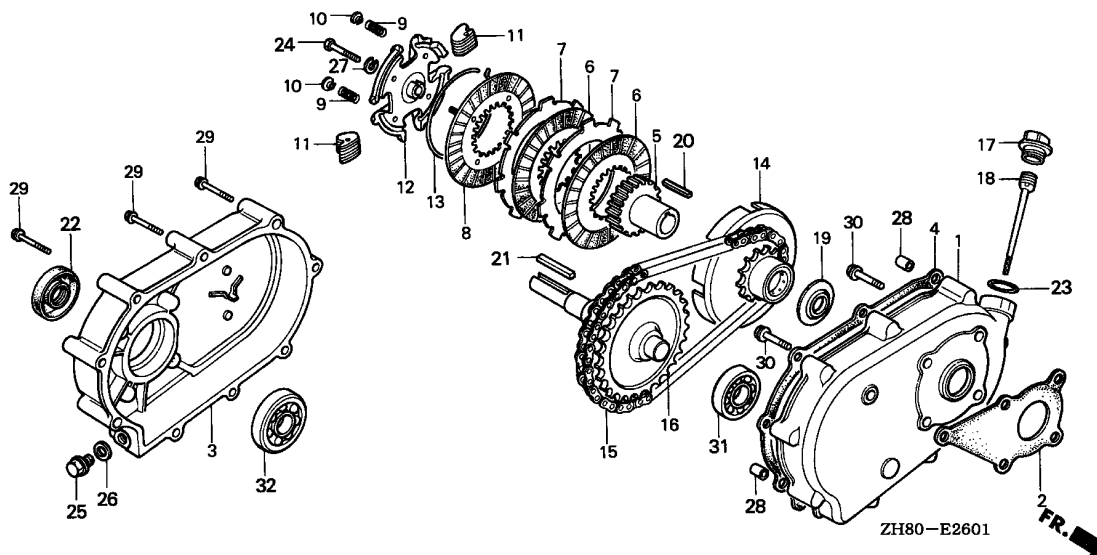

Ref. No.	L.O.N.	(Relative ref. Number) Description	F.R.T.
1		(2,4)	
1	2141C1	CASE, REDUCTION	0.3
3	2141D0	COVER, REDUCTION AND/OR PACKING, REDUCTION COVER	0.3
6		(7)	
6	2101G4	DISC, CLUTCH FRICTION	0.3
8	2101U7	PLATE, CLUTCH PRESSURE	0.3
15	2141C2	CHAIN, DRIVE	0.3
16	2141H4	SHAFT, POWER TAKE OFF	0.3
22	2141L3	OIL SEAL, POWER TAKE OFF SHAFT (A)	0.3
31	2141A7	BEARING, POWER TAKE OFF SHAFT :FRONT	0.4
32	2141L0	BEARING, POWER TAKE OFF SHAFT :REAR	0.4

Ref. No.	Part No.	Description	Reqd. QTY				Serial No.	Parts catalogue code
			(1)	GX160K1 (2)	(3)	(4)		
1	21510-883-621	CASE, REDUCTION	1	1	-	-	RAC, RD, RD4, REX4, RFR, RFR2, RH, RHA, RHA2, RHQ4, RH2, RH26, RMB4, RMD, RMG2, RNG, RSK, RSS1, RTB2, RX, RXE, RXE2, RXE4, RXU, RX4, R1	
2	21591-ZH8-620	PACKING, REDUCTION CASE	1	1	-	-	RAC, RD, RD4, REX4, RFR, RFR2, RH, RHA, RHA2, RHQ4, RH2, RH26, RMB4, RMD, RMG2, RNG, RSK, RSS1, RTB2, RX, RXE, RXE2, RXE4, RXU, RX4, R1	
3	21610-822-611	COVER, REDUCTION	1	1	-	-	RAC, RD, RD4, REX4, RFR, RFR2, RH, RHA, RHA2, RHQ4, RH2, RH26, RMB4, RMD, RMG2, RNG, RSK, RSS1, RTB2, RX, RXE, RXE2, RXE4, RXU, RX4, R1	
4	21691-ZH8-800	PACKING, REDUCTION COVER	1	1	-	-	RAC, RD, RD4, REX4, RFR, RFR2, RH, RHA, RHA2, RHQ4, RH2, RH26, RMB4, RMD, RMG2, RNG, RSK, RSS1, RTB2, RX, RXE, RXE2, RXE4, RXU, RX4, R1	
5	22121-883-620	CENTER, CLUTCH	1	1	-	-	RAC, RD, RD4, REX4, RFR, RFR2, RH, RHA, RHA2, RHQ4, RH2, RH26, RMB4, RMD, RMG2, RNG, RSK, RSS1, RTB2, RX, RXE, RXE2, RXE4, RXU, RX4, R1	
6	22201-822-610	DISK, CLUTCH FRICTION	2	2	-	-	RAC, RD, RD4, REX4, RFR, RFR2, RH, RHA, RHA2, RHQ4, RH2, RH26, RMB4, RMD, RMG2, RNG, RSK, RSS1, RTB2, RX, RXE, RXE2, RXE4, RXU, RX4, R1	
7	22311-822-610	PLATE, CLUTCH	2	2	-	-	RAC, RD, RD4, REX4, RFR, RFR2, RH, RHA, RHA2, RHQ4, RH2, RH26, RMB4, RMD, RMG2, RNG, RSK, RSS1, RTB2, RX, RXE, RXE2, RXE4, RXU, RX4, R1	
8	22350-822-610	PLATE COMP., CLUTCH PRESSURE	1	1	-	-	RAC, RD, RD4, REX4, RFR, RFR2, RH, RHA, RHA2, RHQ4, RH2, RH26, RMB4, RMD, RMG2, RNG, RSK, RSS1, RTB2, RX, RXE, RXE2, RXE4, RXU, RX4, R1	
9	22411-822-611	SPRING, CLUTCH FREE	4	4	-	-	RAC, RD, RD4, REX4, RFR, RFR2, RH, RHA, RHA2, RHQ4, RH2, RH26, RMB4, RMD, RMG2, RNG, RSK, RSS1, RTB2, RX, RXE, RXE2, RXE4, RXU, RX4, R1	
10	22421-822-610	HOLDER, CLUTCH SPRING	4	4	-	-	RAC, RD, RD4, REX4, RFR, RFR2, RH, RHA, RHA2, RHQ4, RH2, RH26, RMB4, RMD, RMG2, RNG, RSK, RSS1, RTB2, RX, RXE, RXE2, RXE4, RXU, RX4, R1	
11	22521-822-610	WEIGHT, CLUTCH	48	48	-	-	RAC, RD, RD4, REX4, RFR, RFR2, RH, RHA, RHA2, RHQ4, RH2, RH26, RMB4, RMD, RMG2, RNG, RSK, RSS1, RTB2, RX, RXE, RXE2, RXE4, RXU, RX4, R1	
12	22531-883-620	HOLDER, CLUTCH WEIGHT	1	1	-	-	RAC, RD, RD4, REX4, RFR, RFR2, RH, RHA, RHA2, RHQ4, RH2, RH26, RMB4, RMD, RMG2, RNG, RSK, RSS1, RTB2, RX, RXE, RXE2, RXE4, RXU, RX4, R1	
13	22535-822-610	CENTER, CLUTCH WEIGHT	1	1	-	-	RAC, RD, RD4, REX4, RFR, RFR2, RH, RHA, RHA2, RHQ4, RH2, RH26, RMB4, RMD, RMG2, RNG, RSK, RSS1, RTB2, RX, RXE, RXE2, RXE4, RXU, RX4, R1	

Ref. No.	Part No.	Description	Reqd. QTY				Serial No.	Parts catalogue code
			(1)	(2)	(3)	(4)		
14	23120-883-620	SPROCKET COMP., DRIVE	1	1	-	-	RAC, RD, RD4, REX4, RFR, RFR2, RH, RHA, RHA2, RHQ4, RH2, RH26, RMB4, RMD, RMG2, RNG, RSK, RSS1, RTB2, RX, XE, XE2, XE4, RXU, RX4, R1	
15	23161-822-611	CHAIN, DRIVE (RK428SH-36LE) ..	1	1	-	-	RAC, RD, RD4, REX4, RFR, RFR2, RH, RHA, RHA2, RHQ4, RH2, RH26, RMB4, RMD, RMG2, RNG, RSK, RSS1, RTB2, RX, XE, XE2, XE4, RXU, RX4, R1	
16	23711-822-610	SHAFT COMP., P.T.O. (28T) ...	1	1	-	-	RAC, RD, RD4, REX4, RFR, RFR2, RH, RHA, RHA2, RHQ4, RH2, RH26, RMB4, RMG2, RSK, RSS1, RTB2, RX, XE, XE2, XE4, RXU, RX4, R1	
17	23711-ZH8-S70	SHAFT COMP., P.T.O. (MIDGETY)	1	-	-	-	RMD, RNG	
	25620-805-611	CAP, REDUCTION OIL (BLACK) ..	1	1	-	-	RAC, RD, RD4, REX4, RFR, RFR2, RH, RHA, RHA2, RHQ4, RH2, RH26, RMB4, RMD, RMG2, RNG, RSK, RSS1, RTB2, RX, XE, XE2, XE4, RXU, RX4, R1	
	25620-805-612	CAP, REDUCTION OIL (GRAY) ...	1	-	-	-	RD, RD4, RH, RHA2, RHQ4, RH2, RH26, RMB4, RMD, RMG2, RSK, RSS1, RTB2, RX, XE, XE2, XE4, RXU, RX4	
18	25651-883-621	GAUGE, OIL LEVEL	1	1	-	-	RAC, RD, RD4, REX4, RFR, RFR2, RH, RHA, RHA2, RHQ4, RH2, RH26, RMB4, RMD, RMG2, RNG, RSK, RSS1, RTB2, RX, XE, XE2, XE4, RXU, RX4, R1	
19	90403-883-620	WASHER, THRUST, 20MM	1	1	-	-	RAC, RD, RD4, REX4, RFR, RFR2, RH, RHA, RHA2, RHQ4, RH2, RH26, RMB4, RMD, RMG2, RNG, RSK, RSS1, RTB2, RX, XE, XE2, XE4, RXU, RX4, R1	
20	90741-883-621	KEY, 5MM	1	1	-	-	RAC, RD, RD4, REX4, RFR, RFR2, RH, RHA, RHA2, RHQ4, RH2, RH26, RMB4, RMD, RMG2, RNG, RSK, RSS1, RTB2, RX, XE, XE2, XE4, RXU, RX4, R1	
21	90741-889-810	KEY, 7X7X33(YELLOW)	1	1	-	-	RD, RD4, REX4, RFR, RFR2, RH, RHA, RHA2, RHQ4, RH2, RH26, RMB4, RMD, RMG2, RSS1, RTB2, RX, XE, XE2, XE4, RXU, RX4, R1	
22	91202-805-610	OIL SEAL (PJ30507)	1	1	-	-	RAC, RD, RD4, REX4, RFR, RFR2, RH, RHA, RHA2, RHQ4, RH2, RH26, RMB4, RMD, RMG2, RNG, RSK, RSS1, RTB2, RX, XE, XE2, XE4, RXU, RX4, R1	
23	91301-805-000	O-RING, 26X2.7	1	1	-	-	RAC, RD, RD4, REX4, RFR, RFR2, RH, RHA, RHA2, RHQ4, RH2, RH26, RMB4, RMD, RMG2, RNG, RSK, RSS1, RTB2, RX, XE, XE2, XE4, RXU, RX4, R1	
24	92000-08035-0A	BOLT, HEX., 8X35	1	1	-	-	RAC, RD, RH, RX, XE, RXU, R1	
	92101-08035-0A	1	-	-	-	RD4, REX4, RFR, RFR2, RHA, RHA2, RHQ4, RH2, RH26, RMB4, RMD, RMG2, RNG, RSK, RSS1, RTB2, XE2, XE4, RX4	
25	92800-12000	BOLT, DRAIN PLUG, 12MM	1	1	-	-	RAC, RD, RD4, REX4, RFR, RFR2, RH, RHA, RHA2, RHQ4, RH2, RH26, RMB4, RMD, RMG2, RNG, RSK, RSS1, RTB2, RX, XE, XE2, XE4, RXU, RX4, R1	
26	94109-12000	WASHER, DRAIN PLUG, 12MM	1	1	-	-	RAC, RD, RD4, REX4, RFR, RFR2, RH, RHA, RHA2, RHQ4, RH2, RH26, RMB4, RMD, RMG2, RNG, RSK, RSS1, RTB2, RX, XE, XE2, XE4, RXU, RX4, R1	
27	94111-08000	WASHER, SPRING, 8MM	1	1	-	-	RAC, RD, RD4, REX4, RFR, RFR2, RH, RHA, RHA2, RHQ4, RH2, RH26, RMB4, RMD, RMG2, RNG, RSK, RSS1, RTB2, RX, XE, XE2, XE4, RXU, RX4, R1	
28	94301-08100	DOWEL PIN, 8X10	2	2	-	-	RAC, RD, RD4, REX4, RFR, RFR2, RH, RHA, RHA2, RHQ4, RH2, RH26, RMB4, RMD, RMG2, RNG, RSK, RSS1, RTB2, RX, XE, XE2, XE4, RXU, RX4, R1	
29	95700-06055-00	BOLT, FLANGE, 6X55	9	9	-	-	RAC, RD, RH, RX, XE, RXU, R1	
	95701-06055-00	9	-	-	-	RD4, REX4, RFR, RFR2, RHA, RHA2, RHQ4, RH2, RH26, RMB4, RMD, RMG2, RNG, RSK, RSS1, RTB2, XE2, XE4, RX4	
30	95700-08022-00	BOLT, FLANGE, 8X22	5	5	-	-	RAC, RD, RH, RX, XE, RXU, R1	
	95701-08022-00	5	-	-	-	RD4, REX4, RFR, RFR2, RHA, RHA2, RHQ4, RH2, RH26, RMB4, RMD, RMG2, RNG, RSK, RSS1, RTB2, XE2, XE4, RX4	
31	96100-62050-00	BEARING, RADIAL BALL, 6205 ..	1	1	-	-	RAC, RD, RD4, REX4, RFR, RFR2, RH, RHA, RHA2, RHQ4, RH2, RH26, RMB4, RMD, RMG2, RNG, RSK, RSS1, RTB2, RX, XE, XE2, XE4, RXU, RX4, R1	
32	96100-62060-00	BEARING, RADIAL BALL, 6206 ..	1	1	-	-	RAC, RD, RD4, REX4, RFR, RFR2, RH, RHA, RHA2, RHQ4, RH2, RH26, RMB4, RMD, RMG2, RNG, RSK, RSS1, RTB2, RX, XE, XE2, XE4, RXU, RX4, R1	



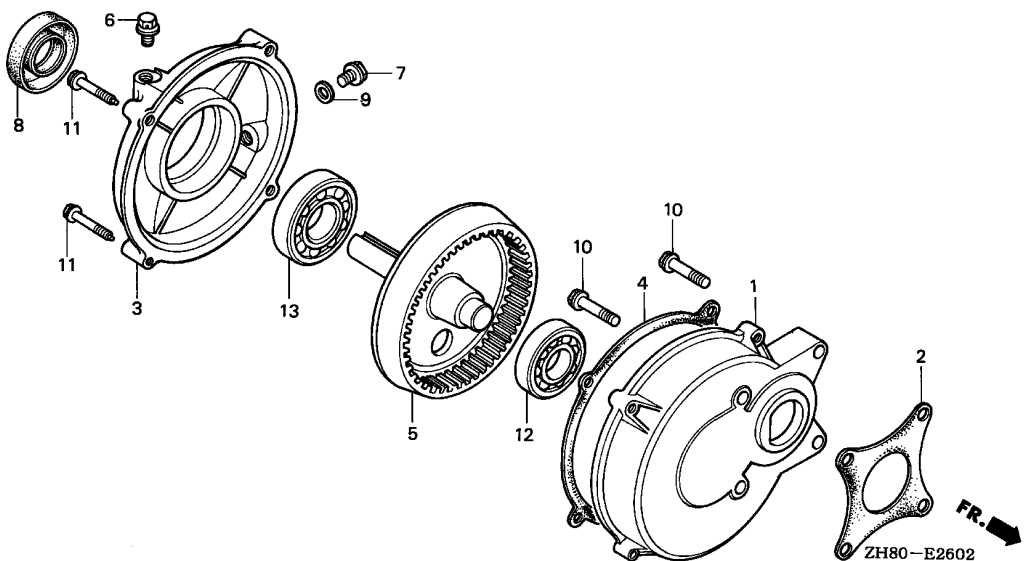

Ref. No.	L.O.N.	(Relative ref. Number) Description	F.R.T.
1	(2,4)		
2141L8		CASE, REDUCTION(A)	0.2
3 2141L9		COVER, REDUCTION AND/OR PACKING, REDUCTION COVER(A)	0.2
5 2141M0		SHAFT, POWER TAKE OFF(A)	0.2
8 2141F2		OIL SEAL, POWER TAKE OFF SHAFT	0.2
12 2141L6		BEARING, POWER TAKE OFF SHAFT (A) :FRONT	0.3
13 2141L7		BEARING, POWER TAKE OFF SHAFT (A) :REAR	0.2



Ref. No.	Part No.	Description	Reqd. QTY				Serial No.	Parts catalogue code
			(1)	(2)	(3)	(4)		
1	21521-883-741	CASE, REDUCTION	1	1	-	-	HG1,HG12,HH,HHQ4,HH26,HX,HXE,HXE2,HXE8,HXQ,HXU,HX2,HX26,HX4,H1	
2	21591-ZH8-740	PACKING, REDUCTION CASE	1	1	-	-	HG1,HG12,HH,HHQ4,HH26,HX,HXE,HXE2,HXE8,HXQ,HXU,HX2,HX26,HX4,H1	
3	21621-883-741	COVER, REDUCTION	1	1	-	-	HG1,HG12,HH,HHQ4,HH26,HX,HXE,HXE2,HXE8,HXQ,HXU,HX2,HX26,HX4,H1	
4	21692-ZH8-800	PACKING, REDUCTION COVER	1	1	-	-	HG1,HG12,HH,HHQ4,HH26,HX,HXE,HXE2,HXE8,HXQ,HXU,HX2,HX26,HX4,H1	
5	23710-883-740	SHAFT, P.T.O.	1	1	-	-	HG1,HG12,HH,HHQ4,HH26,HX,HXE,HXE2,HXE8,HXQ,HXU,HX2,HX26,HX4,H1	
6	90002-883-740	BOLT, BREATHING	1	1	-	-	HG1,HG12,HH,HHQ4,HH26,HX,HXE,HXE2,HXE8,HXQ,HXU,HX2,HX26,HX4,H1	
7	90131-883-000	BOLT, DRAIN PLUG, 12X15	1	1	-	-	HG1,HG12,HH,HHQ4,HH26,HX,HXE,HXE2,HXE8,HXQ,HXU,HX2,HX26,HX4,H1	
8	91202-883-005	OIL SEAL, 25X41X6	1	1	-	-	HG1,HG12,HH,HHQ4,HH26,HX,HXE,HXE2,HXE8,HXQ,HXU,HX2,HX26,HX4,H1	
9	94109-12000	WASHER, DRAIN PLUG, 12MM	1	1	-	-	HG1,HG12,HH,HHQ4,HH26,HX,HXE,HXE2,HXE8,HXQ,HXU,HX2,HX26,HX4,H1	
10	95700-08032-08	BOLT, FLANGE, 8X32	4	4	-	-	HG1,HH,HX,HXU,H1	
	95701-08032-08	4	-	-	-	HG12,HHQ4,HH26,HXE,HXE2,HXE8,HXQ,HX2,HX26,HX4	
11	95700-08035-00	BOLT, FLANGE, 8X35	4	4	-	-	HG1,HH,HX,HXU,H1	
	95701-08035-00	4	-	-	-	HG12,HHQ4,HH26,HXE,HXE2,HXE8,HXQ,HX2,HX26,HX4	
12	96100-62040-00	BEARING, RADIAL BALL, 6204 ..	1	1	-	-	HG1,HG12,HH,HHQ4,HH26,HX,HXE,HXE2,HXE8,HXQ,HXU,HX2,HX26,HX4,H1	
13	96100-63050-00	BEARING, RADIAL BALL, 6305 ..	1	1	-	-	HG1,HG12,HH,HHQ4,HH26,HX,HXE,HXE2,HXE8,HXQ,HXU,HX2,HX26,HX4,H1	

E-26-3

REDUCTION(4)

2-G12

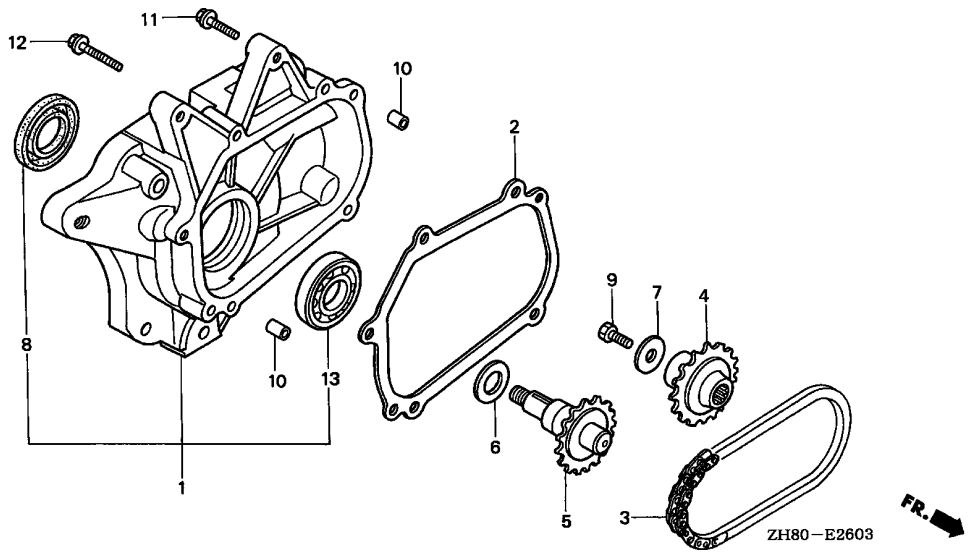

Ref. No.	L.O.N.	(Relative ref. Number) Description	F.R.T.
1	1101G6	(2) COVER, CHAIN CASE AND/OR PACKING, CHAIN CASE COVER(A)	0.4
3	2141M6	CHAIN, POWER TAKE OFF DRIVE(B)	0.4
4	2141M3	SPROCKET, DRIVE(A)	0.4
5	2141M5	SHAFT, POWER TAKE OFF(B)	0.4
8	2141M4	OIL SEAL, POWER TAKE OFF SHAFT (B)	0.4
13	2141M2	BEARING, POWER TAKE OFF SHAFT (A)	0.5

Ref. No.	Part No.	Description	Reqd. QTY				Serial No.	Parts catalogue code
			(1)	(2)	(3)	(4)		
1	11500-ZK7-V00	COVER ASSY., CHAIN CASE	1	-	-	-	AR,ARC6,KR	
2	11521-ZK7-V00	PACKING, CHAIN CASE COVER	1	-	-	-	AR,ARC6,KR	
3	14411-ZK7-V01	CHAIN, P.T.O. DRIVE	1	-	-	-	AR,ARC6,KR	
4	23121-ZK7-V00	SPROCKET, DRIVE (17T)	1	-	-	-	AR,ARC6,KR	
5	23151-ZK7-V00	SHAFT, P.T.O.	1	-	-	-	AR,ARC6,KR	
6	90456-ZE1-000	SPRING, THRUST	1	-	-	-	AR,ARC6,KR	
7	90471-ZE1-610	WASHER, 8MM	1	-	-	-	AR,ARC6,KR	
8	91252-888-003	OIL SEAL, 25X38X7(ARAI)	1	-	-	-	AR,ARC6,KR	
9	92101-08025-0A	BOLT, HEX., 8X25	1	-	-	-	AR,ARC6,KR	
10	94303-08140	DOWEL PIN, 8X14	2	-	-	-	AR,ARC6,KR	
11	95701-08035-00	BOLT, FLANGE, 8X35	4	-	-	-	AR,ARC6,KR	
12	95701-08055-00	BOLT, FLANGE, 8X55	1	-	-	-	AR,ARC6,KR	
13	96100-60050-00	BEARING, RADIAL BALL, 6005	1	-	-	-	AR,ARC6,KR	

2

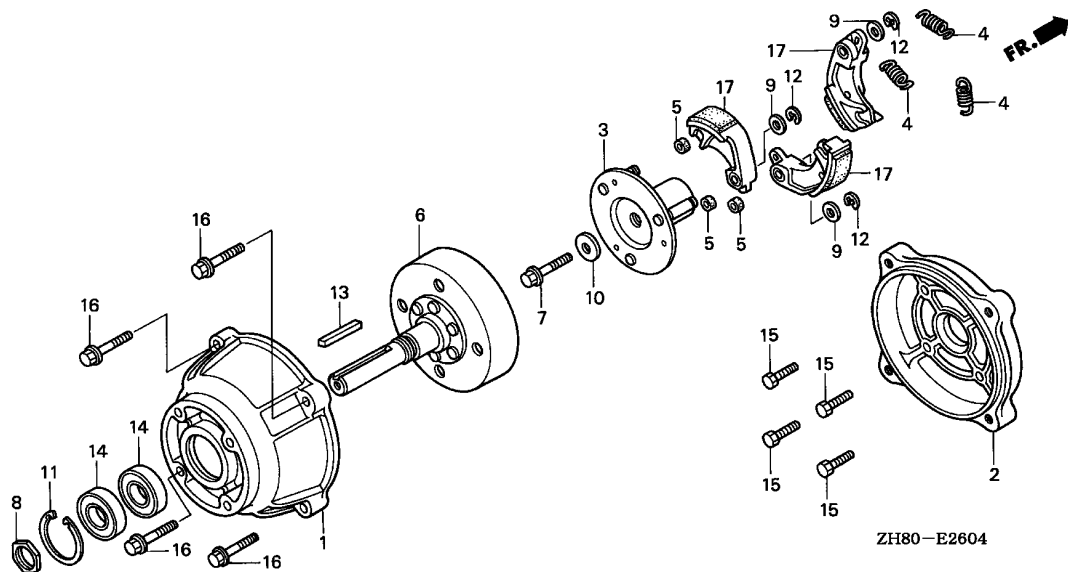

Ref. No.	L.O.N.	(Relative ref. Number) Description	F.R.T.
1	2121B2	COVER, CLUTCH	0.3
2	2121A6	CASE, CLUTCH	0.5
3	2141M7	PLATE, REDUCTION DRIVE	0.4
6	2141H4	SHAFT, POWER TAKE OFF	0.3
14	2141A8	BEARING, POWER TAKE OFF SHAFT	0.3
17	2141M8	WEIGHT SET, CLUTCH	0.5

.NOTE: Same time for two units or more

Ref. No.	Part No.	Description	Reqd. QTY				Serial No.	Parts catalogue code
			(1)	(2)	(3)	(4)		
			GX160K1					
1	21121-ZLO-W80	COVER, CLUTCH	1	-	-	-	-----	BL
2	21512-ZLO-W80	CASE, CLUTCH	1	-	-	-	-----	BL
3	22350-ZLO-W81	PLATE COMP., DRIVE	1	-	-	-	-----	BL
4	22401-ZLO-W81	SPRING, CLUTCH	3	-	-	-	-----	BL
5	22804-148-000	RUBBER, CLUTCH DAMPER	3	-	-	-	-----	BL
6	23150-ZLO-W81	SHAFT COMP., P.T.O.	1	-	-	-	-----	BL
7	90101-GBL-000	BOLT, FLANGE, 8X35	1	-	-	-	-----	BL
8	90202-881-000	NUT, LOCK, 24MM	1	-	-	-	-----	BL
9	90442-KG8-000	WASHER, 9X16X1.4	3	-	-	-	-----	BL
10	90471-435-770	WASHER, 8MM	1	-	-	-	-----	BL
11	90602-ZLO-W80	CIRCLIP, INTERNAL, 47	1	-	-	-	-----	BL
12	90605-166-720	CIRCLIP, 7MM	3	-	-	-	-----	BL
13	90745-ZE1-600	KEY, 4.78X4.78X38	1	-	-	-	-----	BL
14	91008-ZLO-W81	BEARING, RADIAL BALL, 6005 ..	2	-	-	-	-----	BL
15	95701-08022-00	BOLT, FLANGE, 8X22	4	-	-	-	-----	BL
16	95701-08035-00	BOLT, FLANGE, 8X35	4	-	-	-	-----	BL
17	22010-ZLO-W80	WEIGHT SET, CLUTCH	(1)	-	-	-	-----	BL

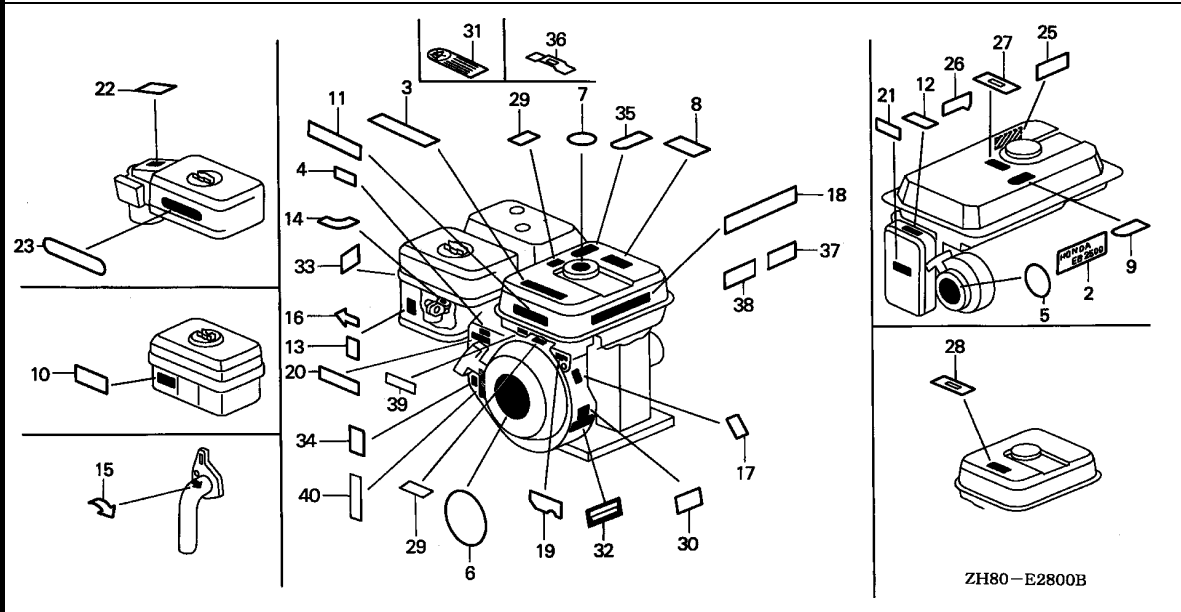

Ref. No.	L.O.N.	(Relative ref. Number) Description	F.R.T.
NO INFORMATION			

Ref. No.	Part No.	Description	Reqd. QTY				Serial No.	Parts catalogue code
			(1)	(2)	(3)	(4)		
2	87101-ZB3-E30	EMBLEM (EB2500)	1	-	-	-	2438430 VS3	
3	87101-733-000	MARK, TOP	1	-	-	-	LTA	
	87522-ZH9-000	LABEL, CAUTION	1	(1)	-	1	H1,LAX,LDB1,LDB3,LDM,LHW,NW,PH,PHU,PM,PM2,PX,QA,QBU2,QNT2,QXB1,Q1,RAC,R1,SAC,SAD2,SDB1,SDN,SDS2,SDS3,SEE,SWX,SW2,S1,TH,THU,T1,U1,VA,VH,VS,VS1,VTD1,VXE,VXP,VX26,V1,W1	
			1	-	-	-	3343603 QE,QXW,RSK,SDS,SE,VXG	
			1	-	-	-	3343604 QNT,VSD	
	87522-ZH9-820	LABEL, CAUTION (THAI)	1	-	1	-	QIH1,QT,QZ	
			-	(1)	-	-		
	87522-ZH9-T00	LABEL, CAUTION	1	-	-	-	QXB,SXB	
	87522-ZH8-W40	MARK, CAUTION	1	-	-	-	QX7,SG24,SX7,VG24,VHA7,VMS7,VSD7,VXE7	
	87522-ZH9-010	LABEL, CAUTION	1	(1)	1	-	ARC6,BL,HH,HH26,HX,HXE,HXE2,HXE8,HXU,HX26,KTA,LD,LH,LHB3,LVL,LW2,LX,LXU,LX26,L1,PHM,PXU,QAB1,QAB3,QA26,QBC2,QBT6,QD,QH,QHE,QHP1,QH26,QM,QMH,QNZ,QP,QVL,QWA4,QX,QXC6,QXE,QXE6,QXE8,QXU,QXW2,QX26,RD,RH,RH26,RX,RXE,RXE2,RXU,SD,SDB3,SD16,SH,SHM,SSK1,SX,SXE,SXS4,SXU,TX,TXU,TX26,UH,UX,UXU,VEBM,VED,VED1,VED6,VIH1,VSX,VSX1,VSX3,VTD,VTU1,VX,VXM,VXU,VXU1,WDA6,WKD6,WKT6,WMT,LJD,LJG,LMT,LSJ,LSS,LSS1,LTK,NJG,NSJ,RSS1,SJG,SMJ,SMJ1,SNX,SNX1,VED5	
	87565-ZE2-000	MARK, FUEL (INTERNAL)	1	-	-	-		
			-	(1)	-	-		
	87565-ZE2-810	MARK, FUEL (EXTERNAL)	-	(1)	-	-		
4	87124-ZV3-010	MARK, EMERGENCY SWITCH INDICATION	1	-	-	-	STM	
			-	-	-	1		
5	87502-ZB2-600	MARK, OIL ALERT	1	-	-	-	8422968 VSB1,VSG,VS4	
			1	-	-	-	2438431 8422968 VS3	
	87502-ZB2-601	1	-	-	-	8422969 VSB1,VSG,VS3,VS4	



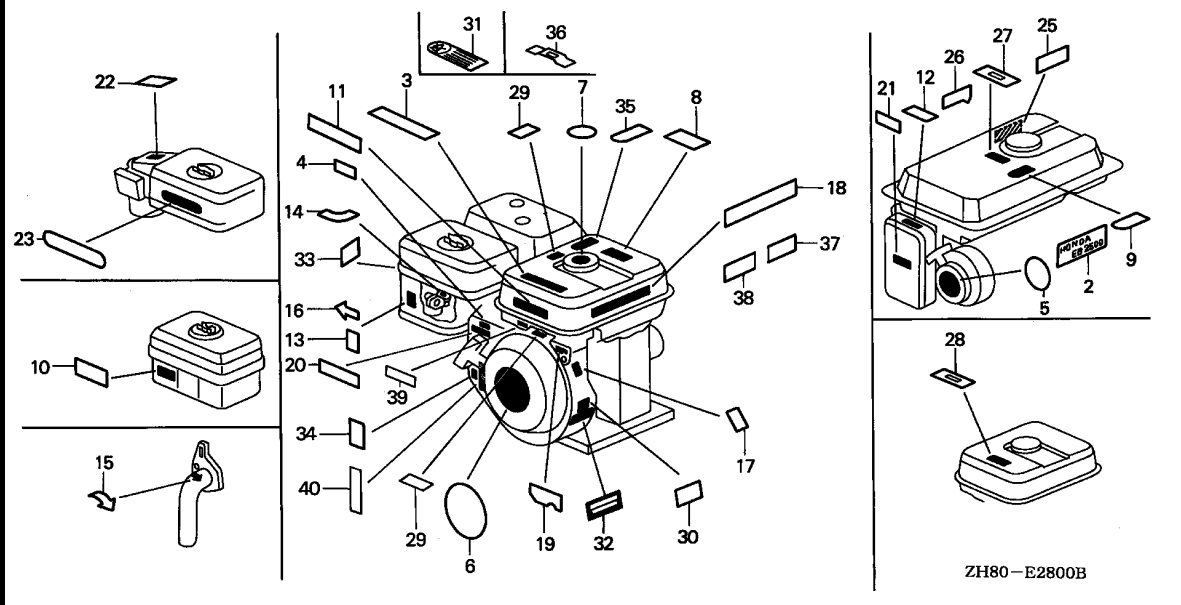

ZH80-E2800B

Ref. No.	Part No.	Description	Reqd. QTY				Serial No.	Parts catalogue code
			(1)	(2)	(3)	(4)		
6	87521-ZH8-000	EMBLEM (5.5PS)	1	-	-	-	2468252 DS,DSP,LJ,LTK,SJ,SMJ,SMJ1,ST,STA,VED2	
			-	(1)	-	-	2468252	
	87521-ZH8-010	EMBLEM (5.5)	1	-	-	-	QBT2,QWM2,QWX3,VED7	
			1	-	-	-	7438467 AR,QCB2,QGR9,QSC9,QWX2,RTB2,SG24,SM12,SSX2,SWX2,TCS2,VG24,WME2	
	87521-ZH8-810	EMBLEM (5.5HP)	1	-	-	-	2468252 EN,ET,ETX,HH,HX,LD,LH,LW2,LX,PH,PM,PM2,PX,QA,QD,QE,QH,QHE,QM	
							QNT,QT,QX,QXC,QXE,QXF,QXS,RAC,RD,RH,RX,RXE,SAC,SD,SDS,SE,SEE	
							SH,STP,STQ,SWX,SW2,SX,SXE,TH,TX,UH,UX,VA,VEBM,VED,VED1,VH,VS	
							VSD,VSD1,VSX,VX,VXE,VXW	
	87521-ZH8-910	EMBLEM (THAI-L/T)	-	(1)	-	-	2468252	
			1	-	-	-	2468252 QZ	

Ref. No.	Part No.	Description	Reqd. QTY				Serial No.	Parts catalogue code
			(1)	(2)	(3)	(4)		
(6)	87521-ZH8-010	EMBLEM (5.5)	GX160K1				2468253	DS,DSP,EN,ET,ETX,H1,LTK,PH,PM,PM2,PX,QA,QT,QXF,QXS,RAC,SAC,SEE STA,STP,SWX,SW2,TH,T1,U1,VA,VH,VS,VXE,VXW,V1
			1	(1)	-	-		
			1	(1)	-	-		
			1	-	1	1		
						7438467	HH,HX,LD,LH,LJ,LW2,LX,L1,QD,QE,QH,QHE,QM,QNT,QX,QXC,QXE,Q1,RD RH,RX,RXE,R1,SD,SDS,SE,SH,SJ,SMJ,SMJ1,ST,STQ,SX,SXE,S1,TX,UH UX,VEBM,VED,VED1,VSD,VSD1,VSX,VX,W1	
							EMA,EMA2,HG1,HG12,HXQ,LAX,LAX2,LDB1,LDB3,LDM,LD4,LHW,LJC7,LJD LSJ,LSS,LSS1,LSS4,NW,PHU,PX2,QAX,QBU2,QNT2,QSC2,QXB,QXB1,QXQ REX4,RFR,RFR2,RHA,RHA2,RMG2,RNG,SAD2,SDB1,SDN,SJC,SMB4,SSK2 STM,SXB,THU,TXC9,UIH,VA2,VEB2,VHQ4,VSDP,VS1,VTD1,VTE2,VTX,VWA VWA2,VXD1,VXE6,VXG,VXP,VXW1,VX26,WKT2	
						7101870	NJC1	
						7438467	ARC6,HHQ4,HH26,HXE,HXE8,HXU,HX2,HX26,HX4,KR,KTA,LHB3,LHQ4,LJG LSJ4,LXU,LX2,LX26,LX4,NJ,NJG,NSJ,PHM,PXU,QAB1,QAB3,QA2,QA2 QA26,QBT6,QCL,QFE4,QGR2,QHP1,QHQ4,QH26,QKA4,QMC6,QMC8,QMD6 QME4,QMH,QMX2,QMZ2,QNT4,QNZ,QP,QPU,QWA4,QXC6,QXC9,QXE2,QXE4 QXE6,QXE8,QXF2,QXM1,QXS2,QXU,QXW,QXW2,QX2,QX22,QX26,QX4,RD4 RHQ4,RH2,RH26,RMB4,RMD,RSK,RSS1,RXE4,RXU,RX4,SCJ,SDB3,SD16,SD4 SHM,SHQ4,SHR4,SJC1,SJC5,SJG,SMC7,SMC9,SMW2,SMX4,SM11,SM14,SSK1 SWG4,SWX2,SWX4,SXE4,SXS4,SXU,SX4,S1CY,TXU,TX2,TX26,TX4,UXU VED2,VED3,VED5,VED6,VHH4,VMB3,VMS4,VMT,VPM4,VPR4,VSX1,VSX3,VTD VTU1,VTX1,VW12,VXD,VXE4,VXM,VXU,VXU1,VXW2,VX2,VX4,WDA6,WJP WKD6,WKT4,WMB0,WME4,WMT	
						6698499	7438467 SHRY	
							2000207 SXP1	
	87521-ZH8-911	EMBLEM (THAI-L/T)	1	-	-	2468253	QZ	
	87521-ZH8-Y10	EMBLEM	1	-	-	6219319	QT	
	87521-ZH8-020	EMBLEM (5.5)	1	(1)	-	7438468	8367036 AR,ARC6,HH,HHQ4,HH26,HX,HXE,HXE8,HXU,HX2,HX26,HX4,KR,KTA,LD,LH LHB3,LHQ4,LJ,LJG,LSJ4,LW2,LX,LXU,LX2,LX26,LX4,L1,NJ,NJG,NSJ PHM,PXU,QAB1,QAB3,QAX2,QA2,QA26,QBT6,QCB2,QCL,QD,QE,QFE4,QGR2 QGR9,QH,QHE,QHP1,QHQ4,QH26,QKA4,QM,QMC6,QMC8,QMD6,QME4,QMH QMX2,QMZ2,QNT,QNT4,QNZ,QP,QPU,QSC9,QWA4,QXW2,QX,QXC,QXC6,QXC9 QXE,QXE2,QXE4,QXE6,QXE8,QXF2,QXM1,QXS2,QXU,QXW,QXW2,QX2,QX22 QX26,QX4,Q1,RD,RD4,RH,RHQ4,RH2,RH26,RMB4,RMD,RSK,RSS1,RTB2,RX RXE,RXE4,RXU,RX4,SCJ,SD,SDB3,SDS,SD16,SD4,SE,SG24,SH,SHM,SHQ4 SHRY,SHR4,SJ,SJC1,SJC5,SJG,SMC7,SMC9,SMJ,SMJ1,SMW2,SMX4,SM11 SM12,SM14,SSK1,SSX2,ST,STM,STQ,SWG4,SWX2,SWX4,SX,SXE,SXE4,SXS4 SXU,SX4,S1,S1CY,TCS2,TX,TXU,TX2,TX26,TX4,UH,UX,UXU,VEBM,VED VED1,VED2,VED3,VED5,VED6,VG24,VHH4,VMB3,VMS4,VMT,VPM4,VPR4,VSD VSD1,VSX,VSX1,VSX3,VTD,VTU1,VTX1,VW12,VX,VXD,VXE4,VXM,VXU,VXU1 VXW2,VX2,VX4,WDA6,WJP,WKD6,WKT4,WMB0,WME2,WME4,WMT	
			1	-	1		HXE2,QIH1,VIH1,WIH1	
			1	-	-	8367036	QBC2,QI2,QX7,RXE2,SX7,VEN2,VMS7,VPM7,VPR7,VSD7,VS17,VXE7,WKT6	
			-	1	-	7438468	8367036 R1,W1	
			-	-	1	2000208	2000271 SXP1	
	87521-ZH8-950	EMBLEM (VIETNAM)	1	-	-		SDS2,SDS3	
	87521-ZK8-W80	EMBLEM	1	-	-		BL	



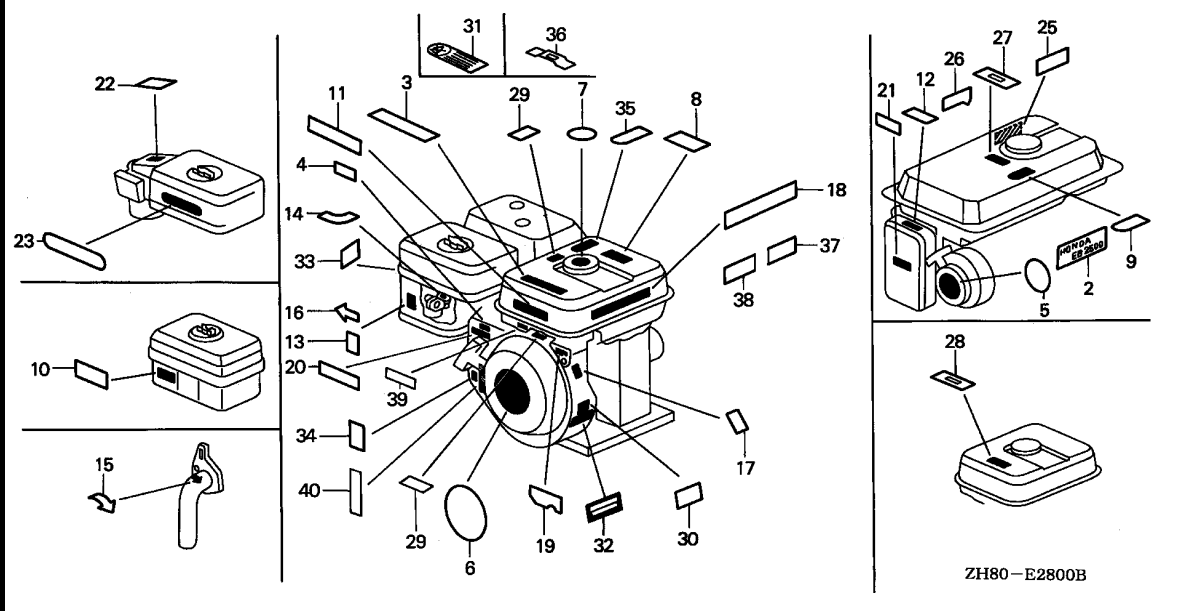

Ref. No.	Part No.	Description	Reqd. QTY				Serial No.	Parts catalogue code
			GX160K1					
			(1)	(2)	(3)	(4)		
(6)	87521-ZH8-030	EMBLEM (5.5)	1	(1)	-	-	8367037	AR,ARC6,HH,HHQ4,HH26,HX,HXE,HXE8,HXU,HX2,HX26,HX4,KR,KTA,LD,LH,LHB3,LHQ4,LJ,LJG,LSJ4,LW2,LX,LXU,LX2,LX26,LX4,L1,NJ,NJG,NSJ,PHM,PXU,QAB1,QAB3,QAX2,QA2,QA26,QBC2,QBT6,QCB2,QCL,QD,QE,QFE4,QGR2,QGR9,QH,QHE,QHP1,QHQ4,QH26,QI2,QKA4,QM,QMC6,QMC8,QMD6,QME4,QMH,QMX2,QMZ2,QNT,QNT4,QNZ,QP,QPU,QSC9,QWA4,QWX2,QX,QXC,QXC6,QXC9,QXE,QXE2,QXE4,QXE6,QXE8,QXF2,QXM1,QXS2,QXU,QXW,QXW2,QX2,QX22,QX26,QX4,QX7,Q1,RD,RD4,RH,RHQ4,RH2,RH26,RMB4,RMD,RSK,RSS1,RTB2,RX,RXE,RXE2,RXE4,RXU,RX4,SCJ,SD,SDB3,SDS,SD16,SD4,SE,SG24,SH,SHM,SHQ4,SHRY,SHR4,SJ,SJC1,SJC5,SJG,SMC7,SMC9,SMJ,SMJ1,SMW2,SMX4,SM11,SM12,SM14,SSK1,SSX2,ST,STM,STQ,SWG4,SWX2,SWX4,SX,SXE,SXE4,SXS4,SXU,SX4,SX7,S1,S1CY,TCS2,TX,TXU,TX2,TX26,TX4,UH,UX,UXU,VEBM,VED,VED1,VED2,VED3,VED5,VED6,VEN2,VG24,VHH4,VMB3,VMS4,VMS7,VMT,VPM4,VPM7,VPR4,VPR7,VSD,VSD1,VSD7,VSX,VSX1,VSX3,VS17,VTD,VTU1,VTX1,VW12,VX,VXD,VXE4,VXE7,VXM,VXU,VXU1,VXW2,VX2,VX4,WDA6,WJP,WKD6,WKT4,WKT6,WMB0,WME2,WME4,WMT,QS2,VES,VHA7,VPMS
			-	1	-	-	8367037	R1,W1
			-	-	-	1	2000272	SXP1
	87570-734-A00	PLATE, EMBLEM (RF)	1	-	-	-	-	LMT
	87521-Z8K-800	EMBLEM	1	-	-	-	8382120	LVL,QVL
	87521-Z8K-801	1	-	-	-	8382121	LVL,QVL
7	87522-ZE1-010	LABEL, FUEL WARNING	1	-	-	-	-	STQ
			1	-	-	-	2710012	DS,DSP,EN,ET,ETX,LJ,LJS,LMT,LTK,SCJ,SJ,SMJ,SMJ1,ST,STA
			-	(1)	-	-	2710012	
	87106-ZH8-S00	MARK, FUEL CAUTION (SHJ)	-	-	1	-	-	UIH,WIH1

Ref. No.	Part No.	Description	Reqd. QTY				Serial No.	Parts catalogue code
			GX160K1					
			(1)	(2)	(3)	(4)		
(7)	87522-ZE1-810	MARK, CAUTION	1	(1)	1	-	BL,H1,LDB1,LDB3,LHB3,LVL,QAB1,QAB3,QIH1,QVL,QXB1,SDB1,SDB3 SDS2,SDS3,STM,U1	
			1	(1)	-	-	3063877 DS,HG1,HH,HX,HXQ,HX2,KTA,LAX,LD,LH,LJD,LW2,LX,LX2,L1,PH,PHU PM2,PX,PX2,QA,QAX,QA2,QD,QE,QH,QHE,QM,QNT,QNZ,QT,QX,QXB,QXC QXE,QXE2,QXF,QXF2,QXQ,QXS,QXS2,QXW,QX2,QZ,Q1,RAC,RD,RH,RH2,RMD RSK,RX,RXE,R1,SAC,SD,SDS,SE,SEE,SH,STP,SWX,SW2,SX,SXB,SXE,S1 TH,THU,TX,TX2,T1,UH,UX,VA,VEBM,VED,VED1,VH,VS,VSD,VSX,VSX1,VS1 VWA,VX,VXE,VXG,VXU,VX2,V1,W1	
			1	-	-	-	2710013 ----- ST	
			1	-	-	-	2710013 3063877 DSP,EN,ET,ETX,LJ,LJS,LMT,LTK,SCJ,SJ,SMJ,SMJ1,STA	
8	87522-ZH8-W40	MARK, CAUTION	1	-	-	1	HHQ4,HX4,LD4,LHQ4,LSJ4,LSS4,LX4,QBC2,QFE4,QHQ4,QA4,QMC6,QMC8 QMD6,QME4,QNT4,QPU,QWA4,QXE4,QX4,RD4,REX4,RHQ4,RMB4,RXE4,RX4 SD4,SHQ4,SHRY,SHR4,SMB4,SMC7,SMC9,SMX4,SM14,SWG4,SWX4,SXE4 SXS4,SX4,S1CY,TX4,VHQ4,VMS4,VSDP,VSW,VXE4,VX4,WKT4,WMB0,WME4	
	87526-ZH8-000	MARK B, COMBINATION	1	-	-	-	3343604 ----- QE,QNT,QXW,RSK,SDS,SE,VSD,VXG	
			1	(1)	-	-	3668136 ----- DS,DSP,LJ,LJD,LJS,LMT,LSS,LTK,L1,RMD,RNG,R1,SCJ,SJ,SJC,SJG,SKM SMJ,SMJ1,SNX,S1,WJP,W1	
			1	-	-	1	KR,LJC7,LSJ,NSJ,QXM1,RSS1,SJC1,SJC5,SM11,SNX1,STM,SXP1 VXD,VXD1	
			1	-	-	-	3675375 ----- LJG	
			1	-	-	-	3678165 ----- VED5	
			1	-	-	-	3771703 ----- NJ,NJG	
9	87522-883-660	MARK, CAUTION (ENGLISH/FRENCH/SPANISH)	1	-	-	-	VEN2,VTE2	
10	87524-883-690	MARK, AIR CLEANER CAUTION (OIL BATH)(ARABIC)	1	-	1	-	LW2,QIH1,QT	
			-	(1)	-	-		
11	87525-ZH8-810	EMBLEM, UPPER (EXTERNAL)	-	(1)	-	-		
	87101-733-000	MARK, TOP	-	-	1	-	UIH,WIH1	
	87522-ZH9-000	LABEL, CAUTION	1	-	-	-	HG1,HXQ,LAX2,PX2,QA,QAX,QBT2,QWM2,QWX3,QXF,QXQ,QXS,SSK2,VEB2 VWA	
	87520-ZH8-000	MARK A, COMBINATION	1	(1)	-	-	3668136 ----- DS,DSP,LJ,LJD,LJS,LMT,LSS,LTK,L1,RMD,RNG,R1,SCJ,SJ,SJC,SJG,SKM SMJ,SMJ1,SNX,S1,WJP,W1	
			1	-	-	-	KR,LJC7,LSJ,NSJ,QXM1,RSS1,SJC1,SJC5,SM11,SNX1,VXD,VXD1	
			1	-	-	-	3675375 ----- LJG	
			1	-	-	-	3678165 ----- VED5	
			1	-	-	-	3771703 ----- NJ,NJG	
	87520-ZK8-840	MARK A, COMBINATION (J-LPG) .	1	-	-	1	STM,SXP1	
	87522-ZH9-010	LABEL, CAUTION	1	-	-	-	AR,HG12,HX,HX2,LX2,QAX2,QA2,QCB2,QGR2,QGR9,QMX2,QMZ2,QSC2,QSC9 QS2,QWX2,QX,QXC,QXC9,QXE,QXE2,QXF2,QXS2,QX2,RH,RH2,RMG2,RTB2 SG24,SMW2,SM12,SSX2,STQ,SWX2,TCS2,TX,TXC9,TX2,VA2,VG24,VWA2,VX VX2,WDA6,WKT2,WME2	
12	87528-ZB2-630	MARK, CHOKE	1	-	-	-	EMA2,VED2,VED3,VEN2,VMT,VPM4,VPM5,VPM7,VPR4,VPR7,VS1,VSG,VSW VS17,VS3,VS4,VTE2,VTX,VTX1	
			1	-	-	-	2744591 ----- VSD1	
13	87528-ZE1-000	MARK, CHOKE	1	-	-	-	2708634 DS,DSP,LJ,LJS,LMT,LTK,SCJ,SJ,SKM,SMJ,SMJ1,STA	
			-	(1)	-	-	2708634	
	87528-ZE1-690	MARK, CHOKE (THAI)	1	-	1	-	QIH1,QT	
			-	(1)	-	-		



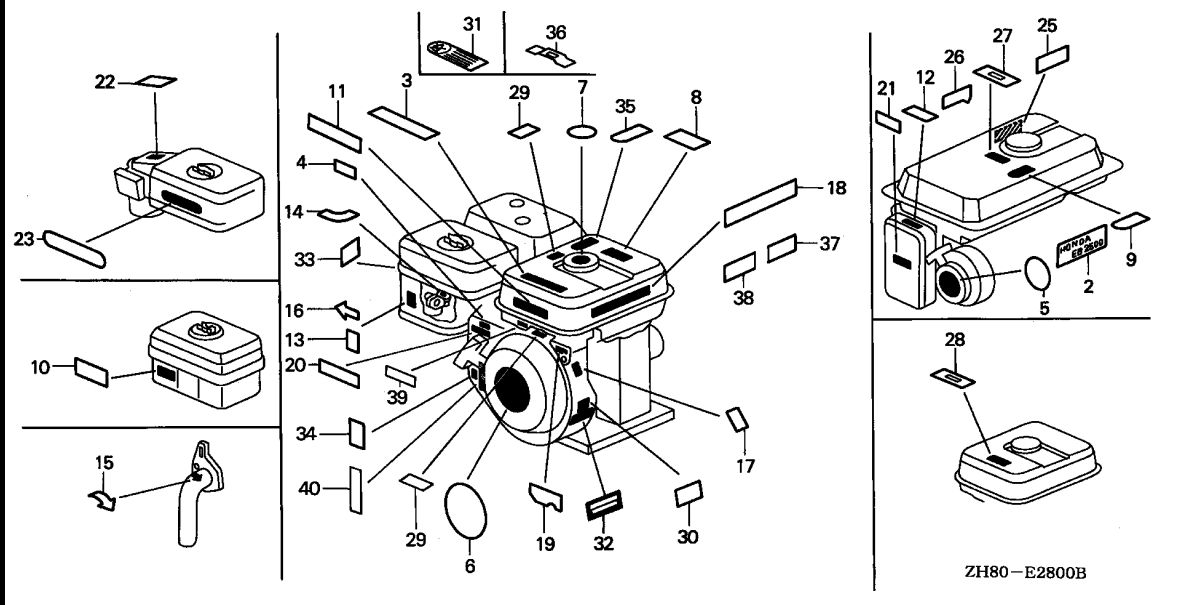

Ref. No.	Part No.	Description	Reqd. QTY				Serial No.	Parts catalogue code
			(1)	(2)	(3)	(4)		
13)	87528-ZE1-810	MARK, CHOKE	1	-	1	-	AR, ARC6, BL, HH, HH26, HX, HXE, HXE2, HXE8, HXQ, HXU, HX2, HX26, KR, KTA, LAX, LAX2, LD, LDM, LH, LHB3, LJC7, LJD, LJG, LSJ, LSS, LVL, LW2, LX, LXU, LX2, LX26, NJ, NJG, NSJ, NW, PH, PHM, PHU, PX, PXU, PX2, QA, QAB1, QAB3, QAX, QAX2, QA2, QA26, QBC2, QBT2, QBT6, QBU2, QCB2, QCL, QGR2, QGR9, QH, QHE, QHP1, QH26, QI2, QMH, QMX2, QMZ2, QNT2, QP, QS2, QVL, QWA4, QWM2, QWX2, QWX3, QX, QXB, QXB1, QXC, QXC6, QXC9, QXE, QXE2, QXE6, QXE8, QXF, QXF2, QXM1, QXQ, QXS, QXS2, QXU, QX2, QX22, QX26, RAC, RFR, RFR2, RH, RHA, RHA2, RH2, RH26, RMD, RMG2, RNG, RSS1, RTB2, RX, RXE, RXE2, RXU, SAC, SAD2, SDN, SDS3, SH, SHM, SJC, SJC1, SJC5, SJG, SMW2, SM11, SM12, SNX, SNX1, SSK1, SSK2, SSS2, SWX, SWX2, SW2, SX, SXB, SXE, SXU, TCS2, TH, THU, TX, TXC9, TXU, TX2, TX26, UH, UX, UXU, VA, VA2, VEBM, VEB2, VED5, VED6, VH, VIH1, VS, VSX, VSX1, VSX3, VS1, VTD, VTD1, VTU1, VMA, VMA2, VW12, VX, VXD, VXD1, VXE, VXE6, VXM, VXU, VXU1, VXX, VXX1, VXX2, VXX6, WDA6, WJP, WKD6, WKT2, WKT6, WME2, WMT	
			1	-	-	-	2708635	DS, DSP, LJ, LJS, SCJ, SJ, SKM, SMJ, SMJ1, STA
			1	-	-	-	2828660	HG1
			1	-	-	-	3343603	QE, QNT, RSK, SE, VSD, VXG
			1	-	-	-	5551817	QSC9
			-	(1)	-	-		
	87528-ZH8-S00	-	-	1	-		UIH, WIH1
	87528-733-E90	MARK, CHOKE (H=36)	1	-	-	-		HHQ4, HX4, LHQ4, LSJ4, LSS4, LX4, QBC2, QFE4, QHQ4, QKA4, QMC8, QMD6, QME4, QNT4, QPU, QWA4, QXE4, QX4, QX7, REX4, RHQ4, RMB4, RXE4, RX4, SG24, SHQ4, SHRY, SHR4, SMB4, SMC7, SMC9, SMX4, SM14, SWX4, SXE4, SXS4, SX4, SX7, S1CY, TX4, VG24, VHA7, VHH4, VHQ4, VMB3, VMS4, VMS7, VSD7, VXE4, VXE7, VX4, WKT4, WME4
			1	-	-	-	3343604	QE, QNT, RSK, SE, VSD, VXG
			1	-	-	-	4764118	SWG4
			1	-	-	-	7744347	VPM7, VPR7

Ref. No.	Part No.	Description	Reqd. QTY				Serial No.	Parts catalogue code
			(1)	(2)	(3)	(4)		
14	87528-ZG0-810	MARK, COCK (EXTERNAL)	1	-	-	-	2578931 ----- QZ	
15	87528-883-661	MARK, CHOKE	1	-	-	1 ----- QZ,SXP1		
16	87528-883-661	MARK, CHOKE	1	-	-	1 ----- STM,VSDP,VXP		
17	87530-ZH8-810	LABEL, SPECIFICATION (5.5HP)	1	-	-	- ----- EN,ET,ETX,HH,HXQ,HXU,HX2,KTA,LD,LH,LW2,LX,LXU,LX2,PH,PM,PM2,PX PXU,PX2,QA2,QD,QE,QH,QHE,QM,QNT,QT,QXB,QXB1,QXE2,QXE8,QXF2,QXQ QXS2,QXU,QXW,QX2,RAC,RD,RH2,RX,RXE,RXU,SAC,SD,SDS,SE,SEE,SH SWX,SW2,SX,SXB,SXE,SXU,TH,TXU,TX2,UH,UX,UXU,VA,VEBM,VED,VED1 VED2,VH,VS,VSD,VSD1,VSX,VSX1,VS1,VS3,VS4,VVA,VXE,VXW2,VX2 HG1,HX,QA,QX,QXC,QXE,QXF,QXS,RFR,RH,STP,STQ,TX,VX,VXW		
	87530-ZH8-000	LABEL, SPECIFICATION (INTERNAL)	1	(1)	-	- ----- H1,Q1,RNG,SJC,SSK2,STA,T1,U1,V1		
			1	(1)	-	- ----- 8066647 L1,QXM1,RMD,RSS1,R1,SCJ,SJ,SJC1,SJC5,SJG,SMJ,SMJ1,SM11,SSK1,ST STM,S1,VXD,VXD1,WJP,W1		
	87530-ZH8-820	LABEL, SPECIFICATION (5.5PS)	1	(1)	-	- ----- DS,DSP,H1,LJD,LMT,LSJ,LSS,LSS1,LTK,Q1,R1,S1,T1,U1,V1,W1		
	87530-ZH8-010	LABEL, SPECIFICATION	1	(1)	-	- ----- 8072944 LJ,LJC7,LJG,LJS,L1,NJ,NJG,NSJ		
	87530-ZH8-821	LABEL, SPECIFICATION (5.5PS)	1	(1)	-	- ----- 8072945 L1,QXM1,RMD,RSS1,R1,SCJ,SJ,SJC1,SJC5,SJG,SMJ,SMJ1,SM11,SSK1,ST STM,S1,VXD,VXD1,WJP,W1		
	87530-ZH8-870	LABEL, SPECIFICATION (NIKKARI)	1	-	-	- ----- 8073614 SNX,SNX1		
	87530-ZH8-871	1	-	-	- ----- 8073615 SNX,SNX1		
18	87532-ZH8-810	MARK, OIL ALERT (EXTERNAL) ..	1	-	1	1 ----- HG12,HXE,HXE2,HXE8,HXQ,HXU,HX2,HX26,LAX,LAX2,LXU,LX2,LX26,PXU PX2,QAX2,QBT2,QBT6,QBU2,QGR2,QGR9,Q12,QMH,QMX2,QNT2,QSC2,QSC9 QS2,QWA4,QWM2,QWX2,QWX3,QXB,QXB1,QXC6,QXC9,QXE2,QXE6,QXE8,QXF2 QXQ,QXS2,QXU,QXW2,QX2,QX26,RXE2,RXU,SAD2,SG24,SMW2,SM12,SSX2 SWX2,SXB,SXS4,SXU,TCS2,TXC9,TXU,TX2,TX26,UXU,VA2,VEB2,VED6 VG24,VIH1,VSX1,VSX3,VTD,VTD1,VVA2,VW12,VXE6,VXM,VXP,VXU,VXU1 VXW2,VX2,VX26,WKD6,WKT2,WKT6,WME2,WMT		
			1	-	-	- ----- 2468253 HX,LX,PX,QX,QXE,RX,RXE,SWX,SX,SXE,TX,UX,VA,VEBM,VED1,VSD1,VSX VX,VXE		
			1	-	-	- ----- 3343604 QXW,VXG		
			1	-	-	- ----- 2468253 3343604 QNT,VSD		
			-	(1)	-	- ----- 2468253		
	87532-ZB4-G60	MARK, OIL ALERT (GERMAN)	1	-	-	1 ----- HG12,HXE,HXE8,HXU,HX26,LAX,LAX2,LXU,LX26,PXU,QAX2,QBT2,QBT6 QBU2,QGR2,QMX2,QNT2,QSC2,QXB1,QXC6,QXC9,QXE6,QXE8,QXU,QXW2 QX26,RXU,SAD2,SG24,SMW2,SSX2,SXU,TXC9,TXU,TX26,UXU,VA2,VEB2 VG24,VWA2,VW12,VXG,VXP,VXU,VXU1,VX26,WKT2,WME2		
			1	-	-	- ----- 2739161 HX,HXQ,HX2,LX,LX2,PX,PX2,QNT,QX,QXB,QXE,QXE2,QXF2,QXQ,QXS2,QXW QX2,RX,RXE,SWX,SX,SXB,SXE,TX,TX2,UX,VA,VEBM,VED1,VSD,VSD1,VSX VSX1,VX,VXE,VXW2,VX2		
			-	(1)	-	- ----- 2739161		
	87532-ZB4-H50	MARK, OIL ALERT (FRENCH)	1	-	-	1 ----- HG12,HXE,HXE8,HXU,HX26,LAX,LAX2,LXU,LX26,PXU,QAX2,QBT2,QBT6 QBU2,QGR2,QMX2,QNT2,QSC2,QXB1,QXC6,QXC9,QXE6,QXE8,QXU,QXW2 QX26,RXU,SAD2,SG24,SMW2,SSX2,SXU,TXC9,TXU,TX26,UXU,VA2,VEB2 VED6,VG24,VWA2,VW12,VXP,VXU,VXU1,VX26,WKD6,WKT2,WKT6,WME2		
			1	-	-	- ----- 2739161 HX,HXQ,HX2,LX,LX2,PX,PX2,QX,QXB,QXE,QXE2,QXF2,QXQ,QXS2,QX2,RX RXE,SWX,SX,SXB,SXE,TX,TX2,UX,VA,VEBM,VED1,VSX,VSX1,VX,VXE,VXW2 VX2		
			1	-	-	- ----- 3261481 VXG		
			1	-	-	- ----- 2739161 QNT,QXW,VSD,VSD1		
			-	(1)	-	- ----- 2739161		
	87532-ZH8-000	MARK, OIL ALERT (INTERNAL) ..	1	-	-	1 ----- LJJC7,QXM1,SJC1,SJC5,SNX,SNX1,STM,SXP1,VED5,VXD,VXD1		
			1	-	-	- ----- 2468253 SMJ,SMJ1		
			-	1	-	- ----- 2468253		
19	87532-ZE1-000	MARK, OIL ALERT (INTERNAL) ..	1	-	-	- ----- 2468252 SMJ,SMJ1		
			-	(1)	-	- ----- 2468252		



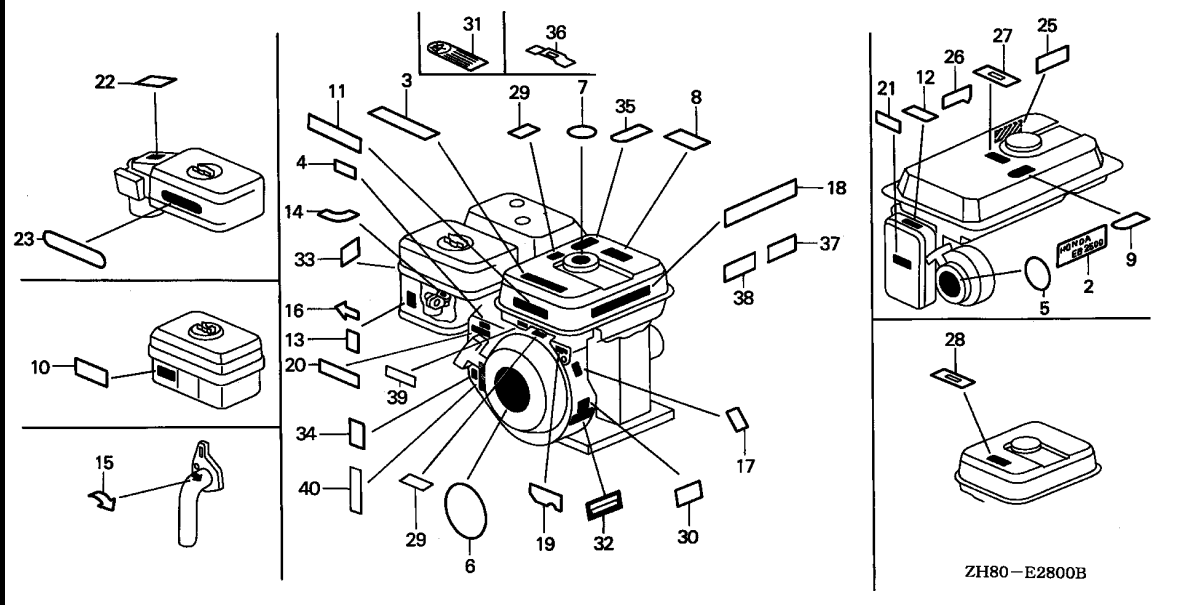

2

Ref. No.	Part No.	Description	Reqd. QTY				Serial No.	Parts catalogue code
			(1)	(2)	(3)	(4)		
19)	87532-ZE1-810	MARK, OIL ALERT (EXTERNAL) ..	1	-	-	-	2468252 HG1,HX,QX,QXC,QXF,QXS,TX,VX,VXW	
			1	-	-	-	2468253 LX,PX,QNT,RX,SWX,SX,UX,VA,VEBM,VED1,VSD,VSX	
			-	(1)	-	-	2468253	
			1	-	-	-	2744591 3344557 VSD1	
			1	-	-	-	VS17	
20	87532-ZH8-W40	MARK, THROTTLE INDICATION ...	1	-	-	-	3344558	VSD1
			1	-	-	-	HHQ4,HX4,LD4,LHQ4,LSJ4,LSS4,LX4,QBC2,QFE4,QHQ4,QKA4,QMC6,QMC8	QMD6,QME4,QNT4,QPU,QWA4,QXE4,QX4,QX7,RD4,REX4,RHQ4,RMB4,RXE4
			1	-	-	-	3261482	QE,QNT,QXW,RSK,SDS,SE
			1	-	-	-	7713250	SWX4
			1	-	-	3261482	3294337 VSD,VSD1,VXG	
21	87533-ZA7-650	MARK, AIR CLEANER	1	-	-	-	2744591 3344557 VSD1	
			1	-	-	-	EMA2,VED2,VED3,VEN2,VMT,VS1,VSG,VS3,VS4,VTE2,VTX,VTX1	
22	87534-ZE1-841	LABEL, AIR CLEANER CAUTION ..	1	-	-	-	QNT4,QSC2,QSC9,QXC,QXC6,QXC9,TXC9	
			-	(1)	-	-		
23	87535-ZE1-840	MARK, AIR CLEANER SALES POINT	1	(1)	-	-	8381117 LSS4,L1,QNT4,QSC2,QSC9,QXC,QXC6,QXC9,Q1,R1,S1,TXC9,W1	
			-	(1)	-	-	H1,T1,U1,V1	
	87535-ZE1-841	1	(1)	-	-	8381118	LSS4,L1,QNT4,QSC2,QSC9,QXC,QXC6,QXC9,Q1,R1,S1,TXC9,W1
25	87539-ZB2-630	MARK, EX. CAUTION	1	-	-	-	VED2,VED3,VEN2,VTE2	
26	87539-898-620	MARK, EX. CAUTION (ENGLISH/FRENCH)	1	-	-	-	VMT,VS1,VSG,VS3,VS4,VTX,VTX1	
27	87565-ZB4-A00	PLATE, FUEL INDICATION	1	-	-	-	VED2,VED3,VMT,VSG,VTE2,VTX,VTX1	

Ref. No.	Part No.	Description	Reqd. QTY				Serial No.	Parts catalogue code
			GX160K1					
			(1)	(2)	(3)	(4)		
28	87565-ZE2-810	MARK, FUEL (EXTERNAL)	1	-	-	-	----- VSX3	
			1	-	-	-	3418182 VXG	
			-	(1)	-	-		
	87565-ZE2-A01	MARK, FUEL (INTERNAL)	1	-	-	-	3418183 ----- VXG	
29	87586-ZH7-W00	LABEL, FUEL CAUTION	1	-	-	-	----- HXQ, HX2, LX2, PX2, QA2, QGR2, QXE2, QXF2, QXQ, QXS2, QX2, RH2, TX2, VXW2	
			2	-	-	-	3417143 ----- VX2	
	87150-ZH8-000	MARK, CAUTION (JAPANESE)	1	-	-	-	3675575 ----- VED2	
30	87594-ZB3-C00	MARK, OIL CAUTION	1	-	-	-	4023626 ----- ST, STM	
	87594-ZB4-A00	1	-	-	-	2438430 ----- VS, VSX, VS3	
			1	-	-	-	----- VED2, VED3, VED7, VEN2, VES, VTE2, VTX, VTX1	
31	87522-ZB3-K01	MARK, FIRE DANGER	-	-	1	-	----- UIH, WIH1	
32	87532-ZH8-810	MARK, OIL ALERT (EXTERNAL) ..	1	-	-	-	----- QWA4, RXE2, VTU1, VTX, VTX1	
33	87135-ZE2-000	LABEL, E-SPEC (HONDA) (EPA STANDARD)	1	-	-	-	----- LVL, QVL, VPM7, VPR7, VS17	
			1	-	-	-	7880502 ----- LHB3	
	87534-ZE1-000	LABEL, AIR CLEANER CAUTION ..	-	(1)	-	-		
	87135-ZE2-010	LABEL, E-SPEC (EPA STANDARD)	-	-	1	-	----- VIH1	
34	87535-ZG0-900	MARK, CARBURETOR DRAIN	1	-	-	-	2369780 ----- ST	
	87535-ZH8-V00	1	-	-	-	----- STM	
			1	-	-	-	2369781 ----- ST	
35	87522-883-660	MARK, CAUTION (ENGLISH/FRENCH/SPANISH)	1	-	-	-	----- VED2, VEN2, VES	
36	87565-ZE2-810	MARK, FUEL (EXTERNAL)	1	-	-	-	----- QSC2	
37	87532-ZB4-G60	MARK, OIL ALERT (GERMAN)	1	-	-	-	----- QAX, VXW1	
			1	-	-	-	2739161 ----- HG1, HX, QX, QXC, QXE, QXF, QXS, TX, VWA, VX, VXW	
	87532-ZB4-H50	MARK, OIL ALERT (FRENCH)	1	-	-	-	----- QAX, VXW1	
			1	-	-	-	2739161 ----- HG1, HX, QX, QXC, QXE, QXF, QXS, TX, VWA, VX, VXW	
38	87532-ZH8-810	MARK, OIL ALERT (EXTERNAL) ..	1	-	-	-	----- QAX, RXE2, VWA, VXW1	
			1	-	-	-	2468253 ----- HG1, HX, QX, QXC, QXE, QXF, QXS, TX, VX, VXW	
39	87135-ZE2-010	LABEL, E-SPEC (EPA STANDARD)	1	-	-	-	----- QX7, SX7, VMS7, VSD7, VSG, VXE7	
	87135-ZE2-020	LABEL, E-SPEC (15.5X27.5) ...	1	-	-	-	----- VES	
40	87135-ZE2-020	LABEL, E-SPEC (15.5X27.5) ...	1	-	-	-	----- VHA7	



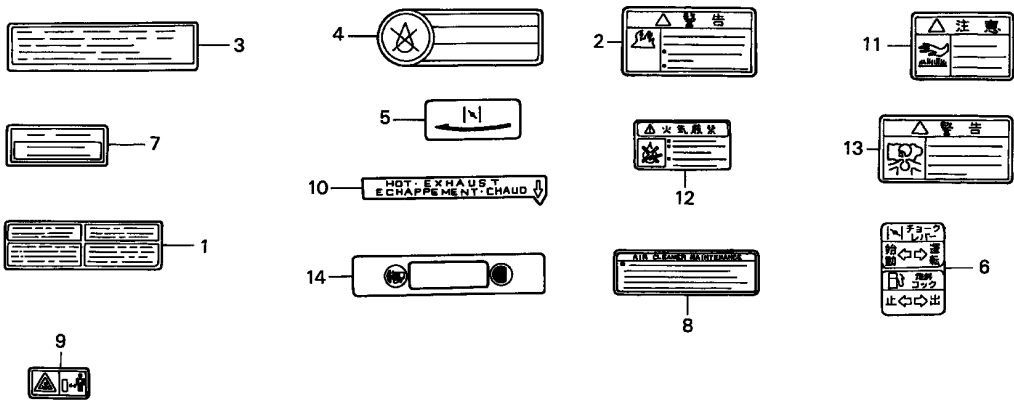

ZH80-E2801

Ref. L.O.N. (Relative ref. Number) F.R.T.
No. Description

NO INFORMATION

Ref. No.	Part No.	Description	Reqd. QTY				Serial No.	Parts catalogue code
			(1)	(2)	(3)	(4)		
1	78141-YB3-610	MARK, CAUTION (PUMP)	1	-	-	-	QX22	
2	87106-737-J00	MARK, FUEL WARNING	1	-	-	3675575 4023626	ST,STM	
3	87522-ZH9-010	LABEL, CAUTION	1	-	-	-	QCL,STQ	
4	87522-883-660	MARK, CAUTION (ENGLISH/FRENCH/SPANISH)	1	-	-	-	VED3,VED7,VES	
5	87528-ZB2-630	MARK, CHOKE	1	-	-	-	EMA,VED3,VED7,VES	
6	87528-777-000	MARK, CHOKE	1	-	-	-	SM11	
7	87532-ZH8-810	MARK, OIL ALERT (EXTERNAL) ..	1	-	-	-	QCL,QX22	
8	87533-ZC0-630	MARK, AIR CLEANER	1	-	-	-	EMA,VED3,VED7,VES	
9	87539-ZA8-660	MARK, EX. CAUTION	1	-	-	-	VSW	
10	87539-ZB2-630	MARK, EX. CAUTION	1	-	-	-	VED3,VED7,VES	
11	87539-737-J00	MARK, HEAT CAUTION	1	-	-	3675575 4023626	ST,STM	
	87522-ZH9-010	LABEL, CAUTION	1	-	-	-	QI2,QX22	
12	87593-737-A00	MARK, USE FUEL	1	-	-	-	SNX,SNX1	
13	87561-733-J00	MARK, EX. GAS WARNING	1	-	-	3675575 4023626	ST,STM	
14	87565-ZB4-A00	PLATE, FUEL INDICATION	1	-	-	-	VED7,VES	

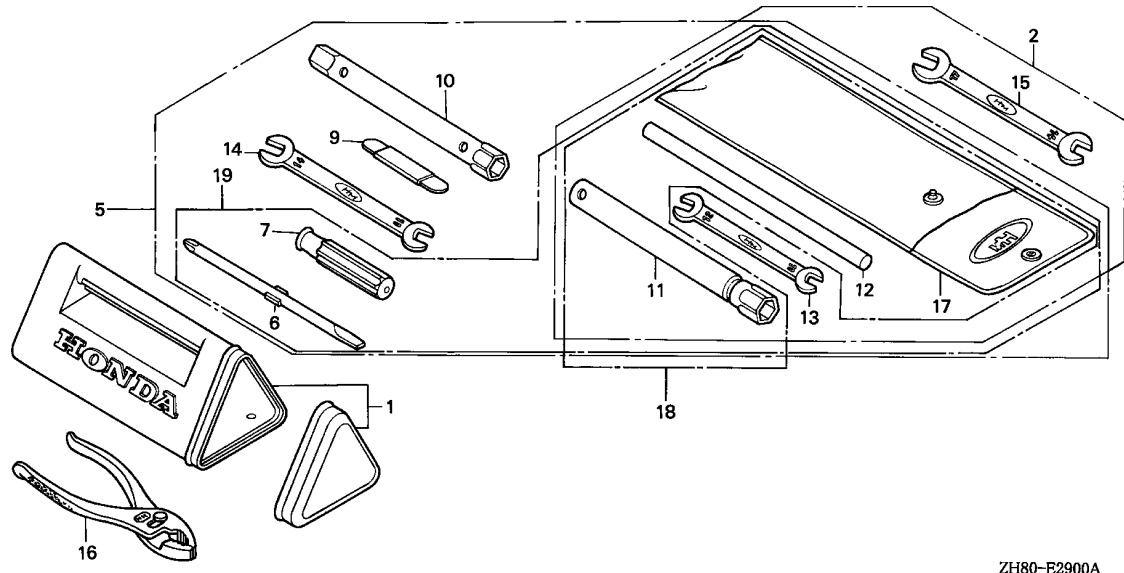

ZH80-E2900A

Ref. No.	L.O.N.	(Relative ref. Number) Description	F.R.T.
----------	--------	------------------------------------	--------

NO INFORMATION

Ref. No.	Part No.	Description	Reqd. QTY				Serial No.	Parts catalogue code
			(1)	(2)	(3)	(4)		
1	83501-ZF1-000	BOX, TOOL	1	-	1	-	LDB3,LHB3,LW2,PM,PM2,QAB3,QM,QT,QZ,SDB3,SDS3,SEE,SWX,SW2,UIH VSB1	
2	89000-ZE1-000	TOOL KIT	1	-	-	-	EMA,LDM,LTA,PHM,PHU,QHP1,QP,SHM,SWG4,THU,VXM	
			1	-	-	-	5165563 EMA2	
5	89001-ZF1-000	BAG SET, TOOL	1	(1)	-	-	LDB3,LHB3,LW2,PM,PM2,QAB3,QM,QT,QZ,SDB3,SDS3,SEE,SWX,SW2,VSB1	
6	89102-538-000	SHAFT, SCREW DRIVER	1	-	-	-	LDB3,LHB3,LW2,PHU,PM,PM2,QAB3,QM,QT,QZ,SDB3,SDS3,SEE,SWX,SW2 THU,VSB1	
	99003-30000	DRIVER MINUS SCREW 3,(NO.2) ..	1	-	-	-	LVL,QVL	
7	89103-538-000	GRIP	1	-	-	-	LDB3,LHB3,LW2,PHU,PM,PM2,QAB3,QM,QT,QZ,SDB3,SDS3,SEE,SWX,SW2 THU,VSB1	
	99003-50000	GRIP, SCREW DRIVER	1	-	-	-	LVL,QVL	
9	89210-ZF1-000	GAUGE ASSY., THICKNESS	1	-	-	-	LDB3,LHB3,LW2,PM,PM2,QAB3,QM,QT,QZ,SDB3,SDS3,SEE,SWX,SW2,VSB1	
10	89216-ZF1-000	WRENCH, BOX	1	-	-	-	LDB3,LHB3,LW2,PM,PM2,QAB3,QM,QT,QZ,SDB3,SDS3,SEE,SWX,SW2,VSB1	
11	89216-ZH8-S00	WRENCH, PLUG	-	-	1	-	QIH1,VIH1,WIH1	



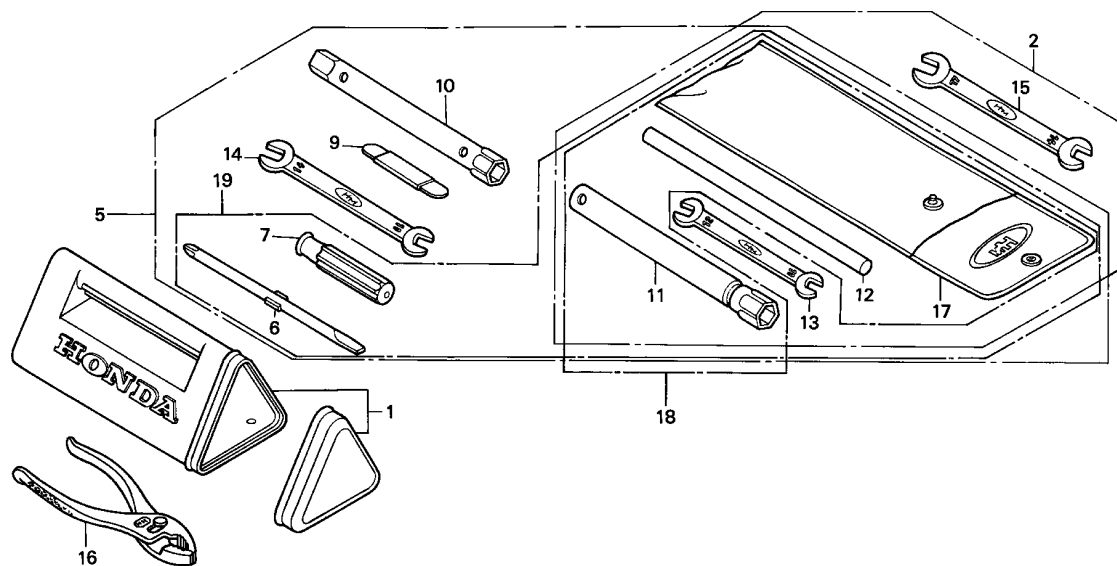

ZH80-E2900A

Ref. No.	Part No.	Description	Reqd. QTY				Serial No.	Parts catalogue code
			(1)	(2)	(3)	(4)		
11)	89218-ZE1-000	WRENCH COMP., SPARK PLUG	1	-	1	-	AR,ARC6,DS,DSP,EMA,EN,ET,ETX,KR,KTA,LDB3,LDM,LHB3,LHW,LJ,LJC7,LJD,LJG,LJS,LMT,LSJ,LSJ4,LSS,LSS1,LSS4,LTA,LTK,LW2,NJ,NJG,NSJ,NW,PHM,PHU,PM,PM2,QA,QAB3,QA2,QBC2,QBU2,QHP1,QM,QMC8,QMD6,QMX2,QMZ2,QNT,QNT4,QP,QSC2,QSC9,QT,QWA4,QXB,QXC,QXC9,QZ,RMD,RNG,RSS1,SAD2,SCJ,SDB3,SDN,SDS3,SEE,SHM,SHRY,SHR4,SJ,SJC,SJC1,SJC5,SJG,SMC7,SMC9,SMJ1,SMX4,SM11,SM12,SM14,SNX,SNX1,SSK1,SSK2,SSX2,ST,STA,STM,STP,STQ,SWG4,SWX,SW2,SXB,S1CY,THU,UIH,VEBM,VED,VED1,VED5,VED6,VMB3,VS,VSB1,VSX,VSX1,VSX3,VS1,VTD,VTD1,VXD,VXD1,VXM,WDA6,WJP,WKD6,WKT2,WKT4,WKT6,WMB0,WME2,WME4,WMT	
			1	-	-	-	6649705	BL
			1	-	-	-	5165563	EMA2
			(1)	-	-	-		QAB1,QA26,QNT2,QXC6,TXC9,VEB2,VG24
	99004-21001	WRENCH, BOX (P21)	1	-	-	-		VED2,VED3,VED7,VEN2,VES,VMT,VSG,VSW,VS3,VS4,VTE2,VTX,VTX1
	99004-21002	WRENCH, PLUG	1	-	-	-		QFE4
	89216-809-000	WRENCH, PLUG	1	-	-	1		SMJ,SMW2,STM,SXP1
			-	(1)	-	-		
	89218-ZE1-000	WRENCH COMP., SPARK PLUG	1	-	-	-		WKT6
			1	-	-	-	5446665	EMA2
	89216-357-000	WRENCH, BOX (P21)	1	-	-	-		NJC1
	99004-21003	WRENCH, PLUG	1	-	-	-		LVL,QVL
12	89219-805-000	HANDLE, BOX WRENCH	1	-	-	1		EMA,LDB3,LDM,LHB3,LTA,LW2,PHM,PHU,PM,PM2,QAB3,QHP1,QM,QP,QT,QZ,SDB3,SDN,SDS3,SEE,SHM,SMX4,SM11,SM12,SM14,ST,STM,SWG4,SWX,SW2,SXP1,THU,VSB1,VXM
			1	-	-	-	6649705	BL
			1	-	-	-	6745959	QMX2
			1	-	-	-	5165563	EMA2
			-	(1)	1	-		

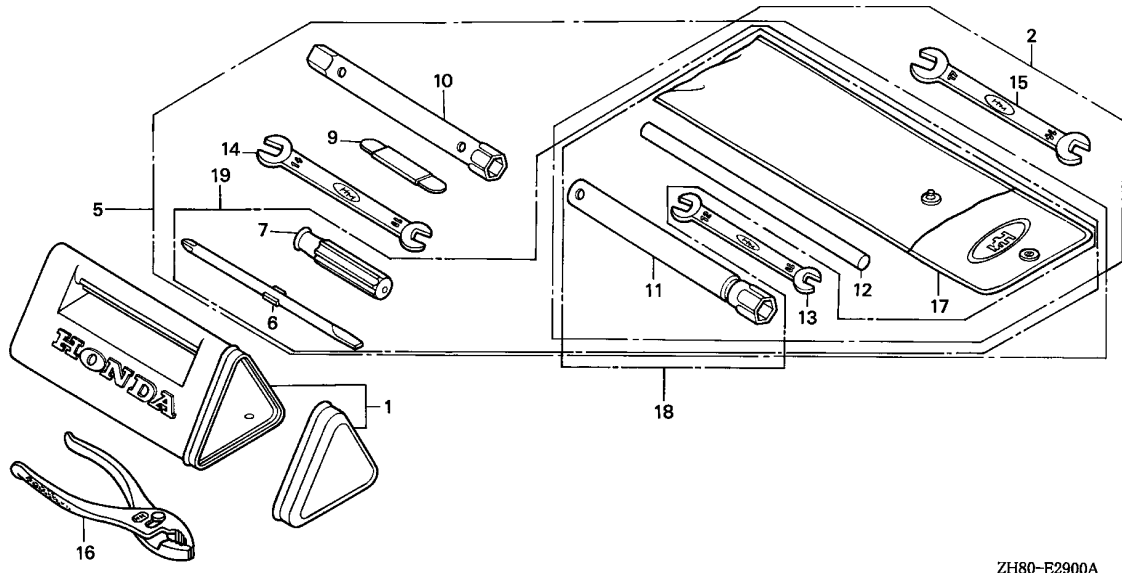

ZH80-E2900A

Ref. No.	Part No.	Description	Reqd. QTY				Serial No.	Parts catalogue code
			(1)	(2)	(3)	(4)		
12)	99005-01000	BAR A, HANDLE	1	-	-	-	LVL,NJC1,QFE4,QVL	
13	99001-10120	SPANNER, 10X12	1	-	-	-	EMA,LDB3,LDM,LHB3,LTA,LVL,LW2,PHM,PHU,PM,PM2,QAB3,QHP1,QM,QP,QT,QVL,QZ,SDB3,SDS3,SEE,SHM,SWG4,SWX,SW2,THU,VSB1,VXM	
			1	-	-	-	5165563 EMA2	
			-	(1)	-	-		
14	99001-10140	SPANNER, 10X14	1	-	-	-	LDB3,LHB3,LW2,PM,PM2,QAB3,QM,QT,QZ,SDB3,SDS3,SEE,SWX,SW2,VSB1	
15	99001-14170	SPANNER, 14X17	1	-	-	-	EMA,LDM,LTA,PHM,PHU,QHP1,QP,SHM,SWG4,THU,VXM	
			1	-	-	-	5165563 EMA2	
			-	(1)	-	-		
16	99002-13500	PLIERS, 135	1	-	-	-	PHU	
			1	-	-	-	7003061 THU	
	89210-GBJ-J10	PLIERS, 135(KOWA)	1	-	-	7003062	THU	
17	99008-02000	BAG, TOOL, 200MM	1	-	-	-	LVL,QFE4,QVL	
	99008-02300	BAG, TOOL, 230MM	1	-	1	-	EMA,LDB3,LDM,LHB3,LTA,LW2,PHM,PHU,PM,PM2,QAB3,QHP1,QM,QP,QT,QZ,SDB3,SDN,SDS3,SEE,SHM,SWG4,SWX,SW2,THU,UIH,VSB1,VXM	
			1	-	-	6649705	BL	
			1	-	-	5165563	EMA2	
			-	(1)	-	-		
18	89000-ZH7-T00	TOOL KIT	1	-	1	-	SDN,UIH	
			1	-	-	6649705	BL	
19	89000-ZB6-000	TOOL KIT	1	-	-	-	LVL,QVL	



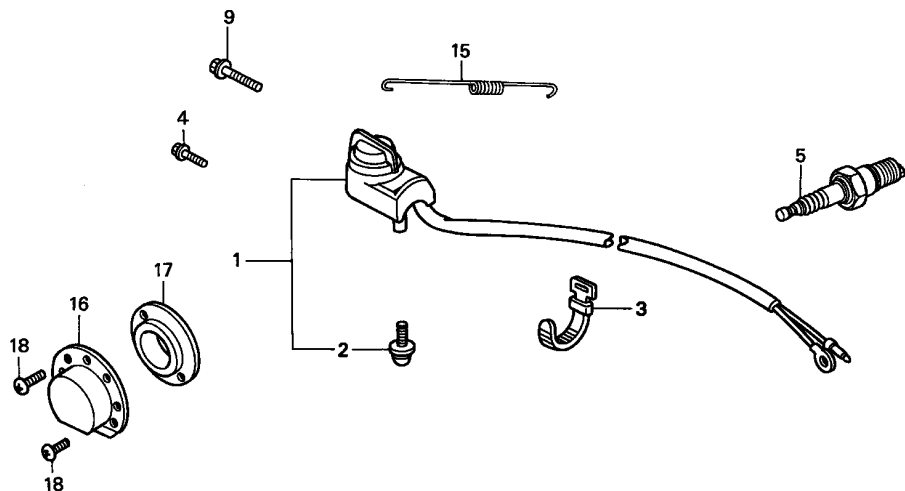

ZH80-E4000

Ref. No.	L.O.N.	(Relative ref. Number) Description	F.R.T.
1	615160	SWITCH, ENGINE STOP(A)	0.1
15	1161C5	SPRING, GOVERNOR	0.2

2

Ref. No.	Part No.	Description	Reqd. QTY				Serial No.	Parts catalogue code
			(1)	(2)	(3)	(4)		
				GX160K1				
1	35120-746-C21	SWITCH ASSY., ENGINE STOP	1	-	-	-	----- QPU	
2	90105-733-D61	BOLT, 3X12(SEMS)	1	-	-	-	----- QPU	
3	95014-62100	BAND B1, WIRE	1	-	-	-	----- QPU	
4	95701-08020-08	BOLT, FLANGE, 8X20	4	-	-	-	----- VTD,VTD1,VTX,VTX1	
5	98079-56846	PLUG, SPARK (BPR6ES)(NGK)	1	-	-	6276050	----- VS,VSB1,VSX3,VS3,VS4,VTD,VTD1,VTX,VTX1	
	98079-56841	PLUG, SPARK (BP6ES)(NGK)	1	-	(1)	-	----- LVL,QIH1,QVL	
			1	-	-	4041863	----- SDS3	
			1	-	-	4224869	----- VSX,VSX1	
			1	-	-	6649705	----- BL	
			1	-	-	6276049	----- VSX3,VTD,VTD1,VTX,VTX1	
			1	-	-	4224869	6276049 VSB1,VS3,VS4	
9	95801-08020-18	BOLT, FLANGE, 8X20	1	-	-	-	----- VEN2,VES	
			1	-	-	3477006	----- VED2	
15	16561-ZL0-U30	SPRING, GOVERNOR	1	-	-	6111881	----- VPR4	
	16561-ZL0-000		1	-	-	-	----- VPM5	
16	18340-ZE1-010	DEFLECTOR COMP.	1	-	-	-	----- SWX2,SWX4	
			1	-	-	7759769	----- QXU,SXU	
17	18522-ZE1-000	GUIDE, MUFFLER	1	-	-	-	----- SWX2,SWX4	
			1	-	-	7759769	----- QXU,SXU	
18	90002-ZG0-003	SCREW, TAPPING, 4X8	2	-	-	-	----- SWX2,SWX4	
			2	-	-	7759769	----- QXU,SXU	

E-40-1

TRANSMISSION CASE

2-H12

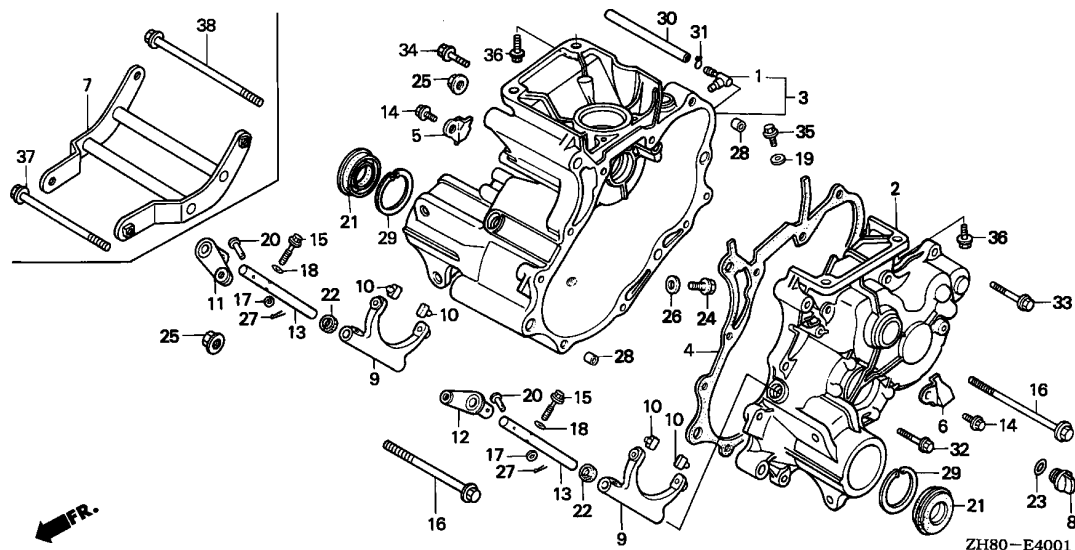

Ref. L.O.N. (Relative ref. Number) F.R.T.
No. Description

NO INFORMATION

Ref. No.	Part No.	Description	Reqd. QTY				Serial No.	Parts catalogue code
			(1)	(2)	(3)	(4)		
			GX160K1					
1	11106-GM2-300	JOINT, BREATHER	1	-	-	-	QFE4	
2	21111-766-000	CASE, R. TRANSMISSION	1	-	-	-	QFE4	
3	21210-766-000	CASE COMP., L. TRANSMISSION ..	1	-	-	-	QFE4	
4	21281-740-020	PACKING, TRANSMISSION CASE ..	1	-	-	-	QFE4	
5	21913-740-000	PLATE, R. SIDE CLUTCH	1	-	-	-	QFE4	
6	21914-740-000	PLATE, L. SIDE CLUTCH	1	-	-	-	QFE4	
7	21931-766-000	GUARD, MISSION	1	-	-	-	QFE4	
8	25611-733-000	CAP, OIL	1	-	-	-	QFE4	
9	40111-740-000	FORK, SIDE CLUTCH	2	-	-	-	QFE4	
10	40112-740-003	PIN, FORK	4	-	-	-	QFE4	
11	40310-740-010	ARM COMP., R. SIDE CLUTCH ...	1	-	-	-	QFE4	
12	40320-740-010	ARM COMP., L. SIDE CLUTCH ...	1	-	-	-	QFE4	
13	40331-740-000	SHAFT, SIDE CLUTCH ARM	2	-	-	-	QFE4	
14	90013-883-000	BOLT, FLANGE, 6X12(CT200) ...	2	-	-	-	QFE4	
15	90028-634-000	BOLT, SPECIAL, 6X21	2	-	-	-	QFE4	
16	90057-671-000	BOLT, ALTERNATOR	2	-	-	-	QFE4	
17	90401-752-003	WASHER, 10MM	2	-	-	-	QFE4	
18	90411-744-000	WASHER, CONICAL SPRING, 6MM ..	2	-	-	-	QFE4	
19	90429-PD1-000	WASHER, SEALING, 8MM	1	-	-	-	QFE4	
20	90752-735-000	PIN, AUXILIARY CHANGE LEVER ..	2	-	-	-	QFE4	
21	91206-733-024	WATER SEAL, 25X52X9.5(NOK) ..	2	-	-	-	QFE4	
22	91251-740-003	OIL SEAL (12X18X4.2)	2	-	-	-	QFE4	
23	91303-800-000	O-RING, 16MM	1	-	-	-	QFE4	
24	92800-12000	BOLT, DRAIN PLUG, 12MM	1	-	-	-	QFE4	

2

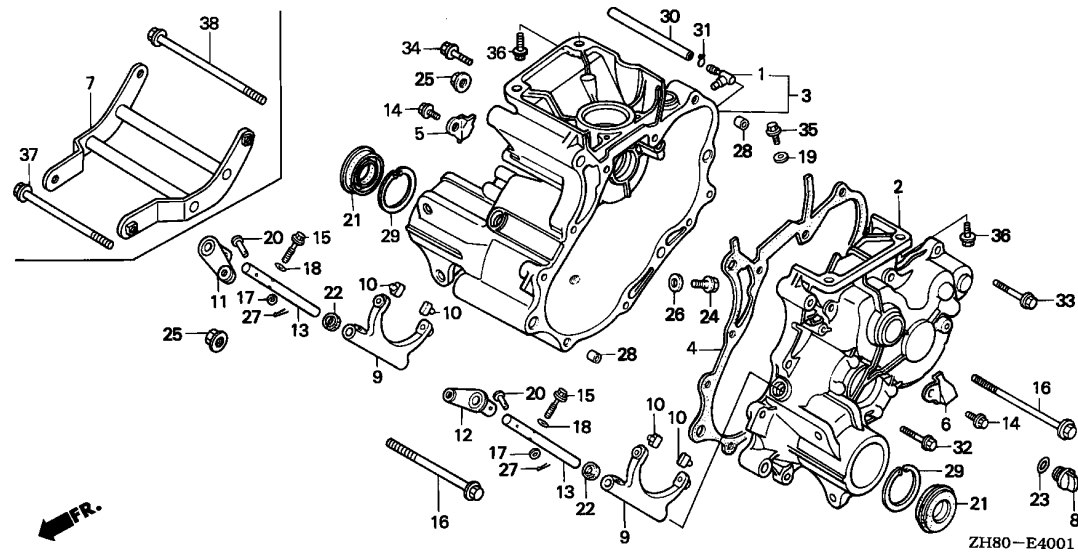

Ref. No.	Part No.	Description	Reqd. QTY				Serial No.	Parts catalogue code
			(1)	(2)	(3)	(4)		
			GX160K1					
25	94050-10000	NUT, FLANGE, 10MM	2	-	-	-	-----	QFE4
26	94109-12000	WASHER, DRAIN PLUG, 12MM	1	-	-	-	-----	QFE4
27	94201-20120	PIN, SPLIT, 2.0X12	2	-	-	-	-----	QFE4
28	94301-08140	DOWEL PIN, 8X14	2	-	-	-	-----	QFE4
29	94520-52000	CIRCLIP, INTERNAL, 52MM	2	-	-	-	-----	QFE4
30	95001-45150-40	TUBE, FUEL, 4.5X150 (95001-45001-60M)	1	-	-	-	-----	QFE4
31	95002-02080	CLIP, TUBE (B8)	1	-	-	-	-----	QFE4
32	95701-06032-00	BOLT, FLANGE, 6X32	5	-	-	-	-----	QFE4
33	95701-06040-00	BOLT, FLANGE, 6X40	4	-	-	-	-----	QFE4
34	95701-08012-00	BOLT, FLANGE, 8X12	1	-	-	-	-----	QFE4
35	95701-08016-00	BOLT, FLANGE, 8X16	1	-	-	-	-----	QFE4
36	95701-08030-00	BOLT, FLANGE, 8X30	4	-	-	-	-----	QFE4
37	95701-10125-00	BOLT, FLANGE, 10X125	1	-	-	-	-----	QFE4
38	95701-10160-00	BOLT, FLANGE, 10X160	1	-	-	-	-----	QFE4

E-40-2

TRANSMISSION GEAR

2-H14

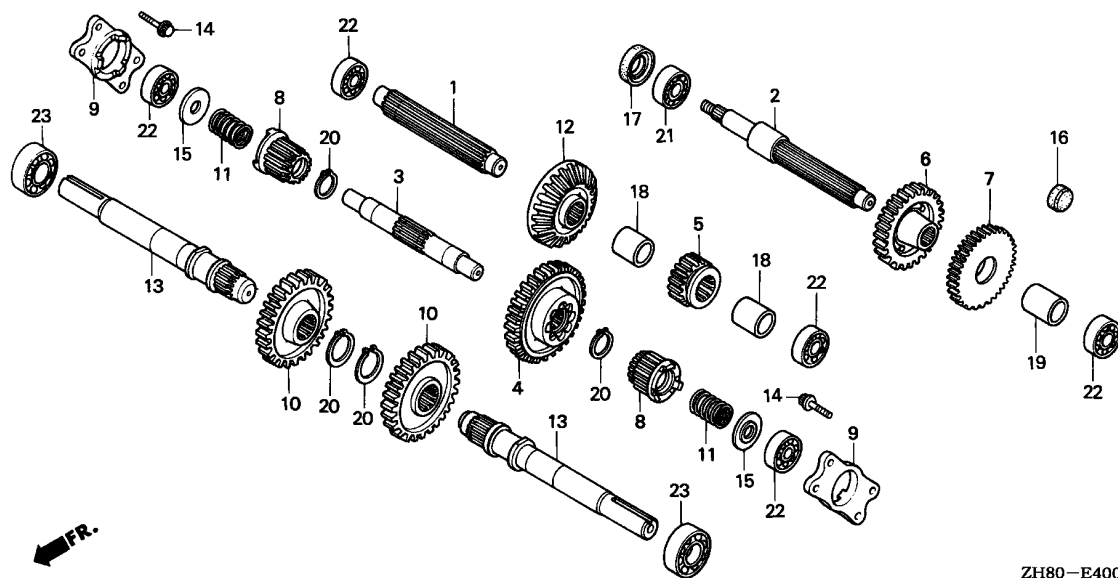

ZH80-E4002

Ref. L.O.N. (Relative ref. Number) F.R.T.
No. Description

NO INFORMATION

Ref. No.	Part No.	Description	Reqd. QTY				Serial No.	Parts catalogue code
			(1)	(2)	(3)	(4)		
1	23112-740-000	SHAFT, INPUT	1	-	-	-	-----	QFE4
2	23221-740-000	COUNTERSHAFT	1	-	-	-	-----	QFE4
3	23231-740-000	SHAFT, SIDE CLUTCH	1	-	-	-	-----	QFE4
4	23407-766-000	GEAR, SIDE CLUTCH DRIVE (49T)	1	-	-	-	-----	QFE4
5	23411-740-010	GEAR, INPUT SHAFT CHANGE (19T)	1	-	-	-	-----	QFE4
6	23422-740-000	GEAR, COUNTERSHAFT (36T)	1	-	-	-	-----	QFE4
7	23431-776-000	GEAR, DRIVEN (42T)	1	-	-	-	-----	QFE4
8	23511-740-000	GEAR, SIDE CLUTCH (16T)	2	-	-	-	-----	QFE4
9	23521-740-000	CASE, SIDE CLUTCH BEARING	2	-	-	-	-----	QFE4
10	23581-740-000	GEAR, FINAL (35T)	2	-	-	-	-----	QFE4
11	40181-776-000	SPRING, SIDE CLUTCH	2	-	-	-	-----	QFE4
12	41141-740-000	GEAR, DRIVEN BEVEL (25T)	1	-	-	-	-----	QFE4
13	42311-766-000	SHAFT, WHEEL	2	-	-	-	6390050	QFE4
	23371-740-020	2	-	-	6390051	-----	QFE4
14	90030-PC8-000	BOLT, SPECIAL, 8MM	8	-	-	-	-----	QFE4
15	90501-740-010	WASHER, CLUTCH SPRING	2	-	-	-	-----	QFE4
16	90871-733-003	PLUG, SEALING, 28(ARAI)	1	-	-	-	-----	QFE4
17	91202-740-003	OIL SEAL, 20X31X7(ARAI)	1	-	-	-	-----	QFE4
18	91551-776-000	COLLAR, (22.3X28.5X37.25)	2	-	-	-	-----	QFE4
19	91552-776-000	COLLAR, (22.3X28.5X43)	1	-	-	-	-----	QFE4
20	94510-25000	CIRCLIP, EXTERNAL, 25MM	4	-	-	-	-----	QFE4
21	96100-60040-00	BEARING, RADIAL BALL, 6004 ..	1	-	-	-	-----	QFE4
22	96100-62030-00	BEARING, RADIAL BALL, 6203 ..	5	-	-	-	-----	QFE4
23	96100-62050-00	BEARING, RADIAL BALL, 6205 ..	2	-	-	-	-----	QFE4

2

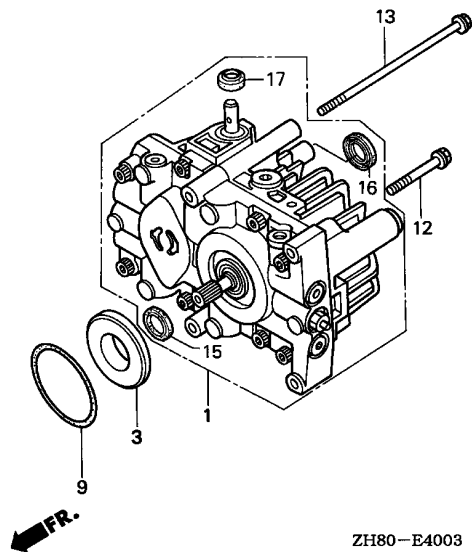
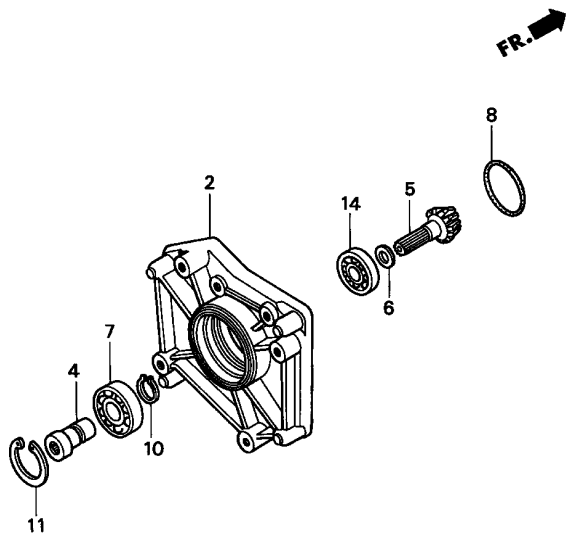

ZH80-E4003

Ref. No.	L.O.N.	(Relative ref. Number) Description	F.R.T.
1	8141B6	HYDROSTATIC TRANSMISSION	0.6
2	4141A3	COVER, BEVEL GEAR	0.4
4	2091D2	SHAFT, JOINT	0.4
5	2141F3	PINION, BEVEL GEAR	0.4
7	2101B8	BEARING, JOINT SHAFT	0.5
14	2101A9	BEARING, BEVEL GEAR PINION ...	0.5



Ref. No.	Part No.	Description	Reqd. QTY				Serial No.	Parts catalogue code
			(1)	(2)	(3)	(4)		
			GX160K1					
1	20005-766-003	H.S.T. ASSY.	1	-	-	-	-----	QFE4
2	21171-766-000	COVER, BEVEL	1	-	-	-	-----	QFE4
3	21178-766-000	BOSS, GUIDE	1	-	-	-	-----	QFE4
4	23218-766-000	SHAFT, JOINT	1	-	-	-	-----	QFE4
5	41131-766-000	PINION, BEVEL	1	-	-	-	-----	QFE4
6	90540-740-000	WASHER, BEVEL GEAR	1	-	-	-	-----	QFE4
7	91001-878-003	BEARING, RADIAL BALL, 62/22 ..	1	-	-	-	-----	QFE4
8	91301-766-003	O-RING, 42.5X3	1	-	-	-	-----	QFE4
9	91307-639-000	O-RING, 64X2	1	-	-	-	-----	QFE4
10	94510-22000	CIRCLIP, EXTERNAL, 22MM	1	-	-	-	-----	QFE4
11	94520-50000	CIRCLIP, INTERNAL, 50MM	1	-	-	-	-----	QFE4
12	95701-08045-00	BOLT, FLANGE, 8X45	2	-	-	-	-----	QFE4
13	95701-08115-00	BOLT, FLANGE, 8X115	2	-	-	-	-----	QFE4
14	96100-62030-00	BEARING, RADIAL BALL, 6203 ..	1	-	-	-	-----	QFE4
15	91201-766-003	OIL SEAL, 15X24X7	1	-	-	-	-----	QFE4
16	91202-766-003	OIL SEAL, 15X35X7	1	-	-	-	-----	QFE4
17	91203-766-003	OIL SEAL, 12X25X7	1	-	-	-	-----	QFE4

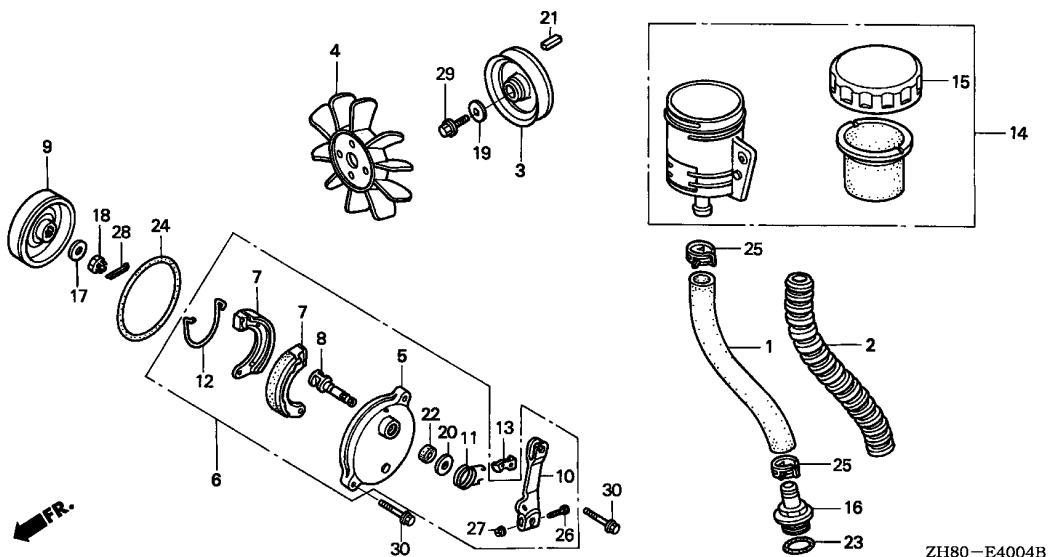

Ref. No.	L.O.N.	(Relative ref. Number) Description	F.R.T.
1	1171A4	TUBE, OIL	0.1
3	2131G8	PULLEY, DRIVE	0.2
4	2101G6	FAN, TRANSMISSION COOLING	0.2
6	7111B5	PANEL ASSEMBLY, BRAKE	0.2
7	7111C0	SHOE, BRAKE	0.3

Ref. No.	Part No.	Description	Reqd. QTY				Serial No.	Parts catalogue code
			(1)	(2)	(3)	(4)		
			GX160K1					
1	15422-776-000	TUBE, OIL	1	-	-	-	-----	QFE4
2	15428-767-000	PROTECTOR, OIL TUBE	1	-	-	-	-----	QFE4
3	22411-734-700	PULLEY, DRIVE (80MM)	1	-	-	-	-----	QFE4
4	40491-776-003	FAN, TRANSMISSION COOLING	1	-	-	-	-----	QFE4
5	43100-740-000	PANEL COMP., BRAKE	1	-	-	-	-----	QFE4
6	43100-776-000	PANEL ASSY., BRAKE	1	-	-	-	-----	QFE4
7	43125-GZ9-003	SHOE COMP., BRAKE (ASK)	2	-	-	-	-----	QFE4
8	43141-740-000	CAM, BRAKE	1	-	-	-	-----	QFE4
9	43210-751-003	DRUM COMP., BRAKE	1	-	-	-	-----	QFE4
10	43410-740-000	ARM, BRAKE	1	-	-	-	-----	QFE4
11	43417-776-000	SPRING, BRAKE ARM	1	-	-	-	-----	QFE4
12	45133-044-000	SPRING, BRAKE SHOE	1	-	-	-	-----	QFE4
13	45135-740-000	PLATE, BRAKE ARM SPRING	1	-	-	-	-----	QFE4
14	56850-767-000	TANK ASSY., OIL	1	-	-	-	-----	QFE4
15	56862-767-300	BODY, OIL CAP	1	-	-	-	-----	QFE4
16	56955-766-000	CONNECTOR, SUCTION PORT	1	-	-	-	-----	QFE4
17	90017-PE0-000	WASHER, 10MM	1	-	-	-	-----	QFE4
18	90301-740-003	NUT, CASTLE, 10MM	1	-	-	-	-----	QFE4
19	90473-842-000	WASHER, 8MM	1	-	-	-	-----	QFE4
20	90529-126-770	WASHER, 10.5MM	1	-	-	-	-----	QFE4
21	90741-732-000	KEY, 5X5X21	1	-	-	-	-----	QFE4
22	91262-740-003	SEAL, BRAKE CAM	1	-	-	-	-----	QFE4
23	91305-KE1-000	O-RING, 19.4X2.3	1	-	-	-	-----	QFE4
24	91352-740-003	O-RING, 100X2	1	-	-	-	-----	QFE4



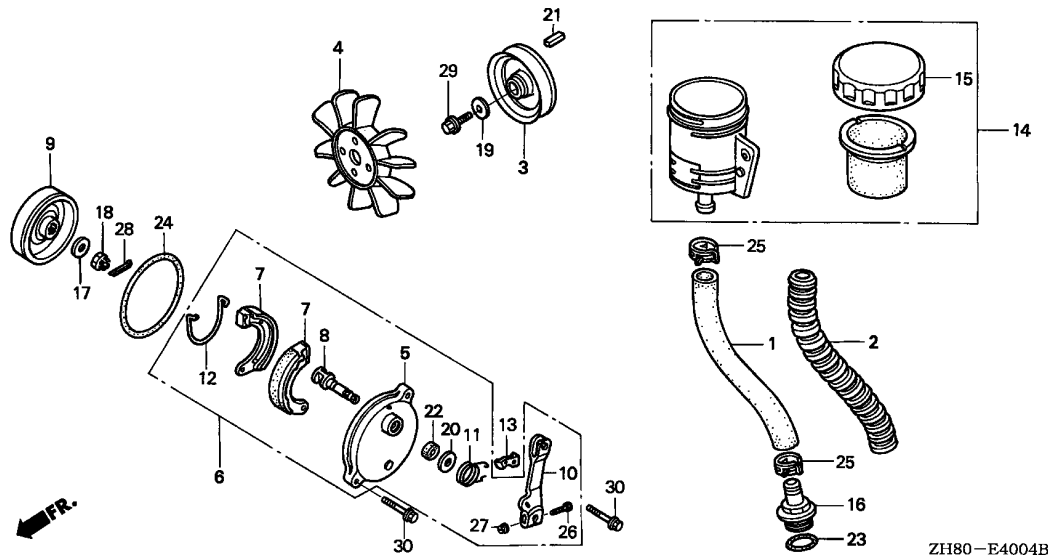

Ref. No.	Part No.	Description	Reqd. QTY				Serial No.	Parts catalogue code
			(1)	(2)	(3)	(4)		
25	91462-SA5-950	CLAMP D, 19MM	2	-	-	-	-----	QFE4
26	92101-05028-0A	BOLT, HEX., 5X28	1	-	-	-	-----	QFE4
27	94050-05000	NUT, FLANGE, 5MM	1	-	-	-	-----	QFE4
28	94201-20200	PIN, SPLIT, 2.0X20	1	-	-	-	-----	QFE4
29	95701-08020-00	BOLT, FLANGE, 8X20	1	-	-	-	-----	QFE4
30	95801-06028-00	BOLT, FLANGE, 6X28	2	-	-	-	-----	QFE4

E-40-5

COMBINATION SWITCH

2-1 2

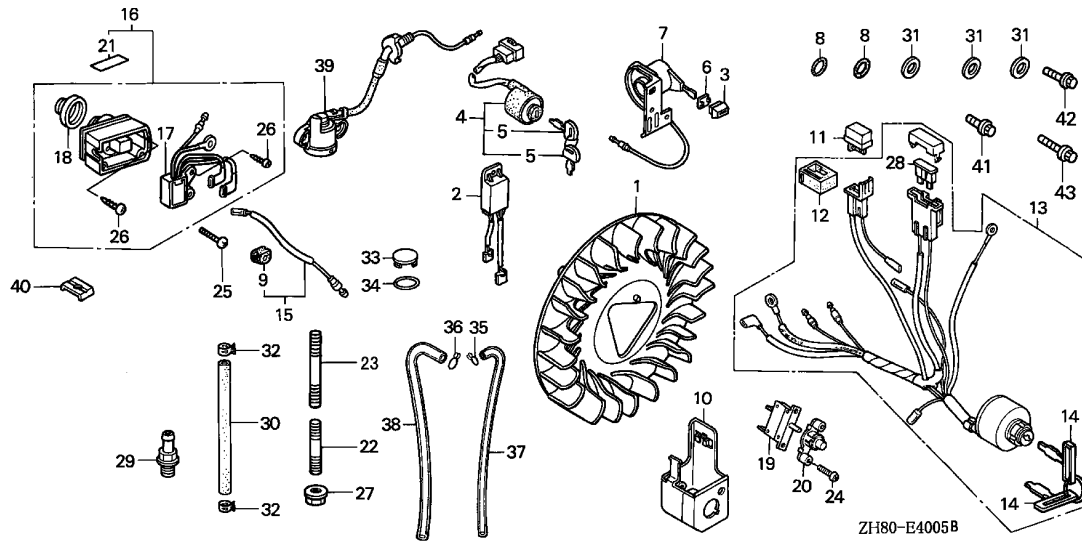

Ref. No.	L.O.N.	(Relative ref. Number) Description	F.R.T.
1	1141G7	FAN, ENGINE COOLING	0.2
2	6131B7	RECTIFIER, REGULATOR	0.2
4	6151E1	SWITCH, COMBINATION	0.2
7	6151B9	SWITCH, ENGINE	0.2
11	6131B8	RECTIFIER, SILICON	0.1
15	6111A3	CORD, ENGINE STOP SWITCH	0.1
16	6151C8	SWITCH, ONE PUSH STOP	0.1
17	6151A2	STOP UNIT, ENGINE	0.2
19	6221D4	PROTECTOR, CIRCUIT	0.2
39	6151E8	SWITCH, OIL LEVEL	0.5

Ref. No.	Part No.	Description	Reqd. QTY				Serial No.	Parts catalogue code
			(1)	(2)	(3)	(4)		
1	19511-ZE3-000	FAN, COOLING	1	-	-	-	SJC1,SJC5	
		(COMPRESSOR COOLING)	1	-	-	-	SJC	
2	31600-KE1-010	RECTIFIER COMP., REGULATOR ..	1	-	-	-	LSS1	
3	32343-892-003	KNOB, COCK LEVER	1	-	-	-	VED3,VED7	
4	35100-752-023	SWITCH ASSY., COMBINATION ...	1	-	-	-	LSS1	
5	35110-VA3-902	KEY ASSY., COMBINATION SWITCH	2	-	-	-	LSS1	
6	36106-892-003	BUSH, CONTROL KNOB	1	-	-	-	VED3,VED7	
7	36110-ZB2-003	SWITCH ASSY., ENGINE	1	-	-	-	VED3,VED7	
8	78118-YB0-003	RING, SEAL (B)	2	-	-	-	WJP,WME4	
9	15521-ZA8-000	GROMMET, CORD	1	-	-	-	LMT	
10	31614-ZE2-003	BRACKET, CASE MOUNTING	1	-	-	-	SNX1	
11	31700-124-008	RECTIFIER ASSY., SILICON (SHINDENGEN)	1	-	-	-	SNX1	
12	32127-738-700	SUSPENSION, COUPLER	1	-	-	-	SNX1	
13	35100-ZE1-812	SWITCH ASSY., COMBINATION ...	1	-	-	-	SNX1	
14	35111-880-003	KEY COMP.	2	-	-	-	SNX1	
15	35112-ZE2-U50	CORD, ENGINE KILL SWITCH (MAMETORA)	1	-	-	-	LMT	
16	35120-734-A21	SWITCH ASSY., ONE PUSH KILL ..	1	-	-	-	LMT	
17	35140-734-971	KILL UNIT, ENGINE	1	-	-	-	LMT	
18	35146-734-A21	CAP, ENGINE KILL SWITCH	1	-	-	-	LMT	
19	38240-VA3-900	PROTECTOR, CIRCUIT (1.0A) ...	1	-	-	-	SNX1	
20	38250-ZA8-701	LENS ASSY., PROTECTOR	1	-	-	-	SNX1	
21	87504-734-800	MARK, ENGINE KILL SWITCH	1	-	-	-	LMT	

2

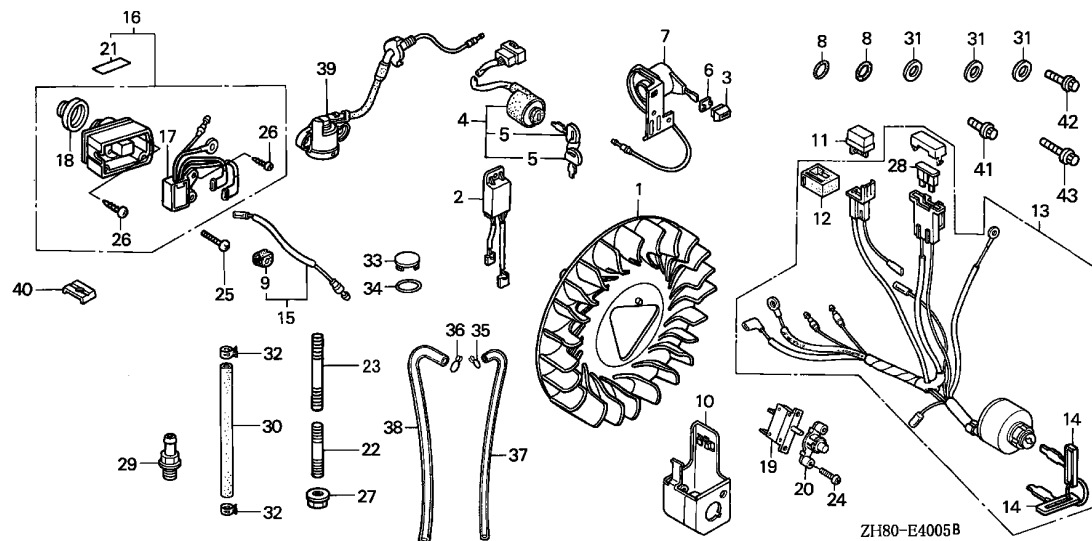

Ref. No.	Part No.	Description	Reqd. QTY				Serial No.	Parts catalogue code
			(1)	(2)	(3)	(4)		
				GX160K1				
22	90001-ZK7-V00	BOLT, STUD, 10X32	3	-	-	-	AR,ARC6,KR	
23	90002-ZK7-V00	BOLT, STUD, 10X60	1	-	-	-	AR,ARC6,KR	
24	93500-03012-OH	SCREW, PAN, 3X12	2	-	-	-	SNX1	
25	93500-05016-OA	SCREW, PAN, 5X16	1	-	-	6698499	SHRY	
			3	-	-	2253855	LMT	
26	93901-22320	SCREW, TAPPING, 3X12	3	-	-	-	LMT	
27	94050-10000	NUT, FLANGE, 10MM	1	-	-	-	SM14	
			4	-	-	-	AR,ARC6,KR	
28	98200-30500	FUSE, BLADE (5A)	1	-	-	-	SNX1	
29	15550-ZK8-P90	JOINT, DRAIN	2	-	-	-	SM11,SM12,SM14	
30	15552-ZB9-000	TUBE, DRAIN	1	-	-	-	SM11,SM12,SM14	
31	90601-ZE1-000	WASHER, DRAIN PLUG, 10.2MM ..	3	-	-	-	SHRY,SM11,SM12,SM14	
32	95002-41200-08	CLAMP, TUBE (D12)	2	-	-	-	SM11,SM12,SM14	
33	17507-ZA0-800	CAP, FUEL METER	1	-	-	-	NJC1	
34	91356-706-000	O-RING, 56X2.4	1	-	-	-	NJC1	
35	95002-35000	CLIP, TUBE (C6.5)	1	-	-	-	NJC1	
36	95002-45000	CLIP, TUBE (C8)	1	-	-	-	NJC1	
37	95003-05021-31	TUBE, VINYL, 3.5X6.5X210 (95003-05001-60M)	1	-	-	-	NJC1	
38	95003-09025-31	TUBE, VINYL, 4.5X8X250 (95003-09001-60M)	1	-	-	-	NJC1	
39	15510-ZE2-043	SWITCH ASSY., OIL LEVEL	1	-	-	6389605	SMJ	
40	16576-891-000	HOLDER, CABLE	1	-	-	6698499	SHRY	
41	95701-06010-00	BOLT, FLANGE, 6X10	5	-	-	-	VEN2	

E-40-5

COMBINATION SWITCH

2-1 4

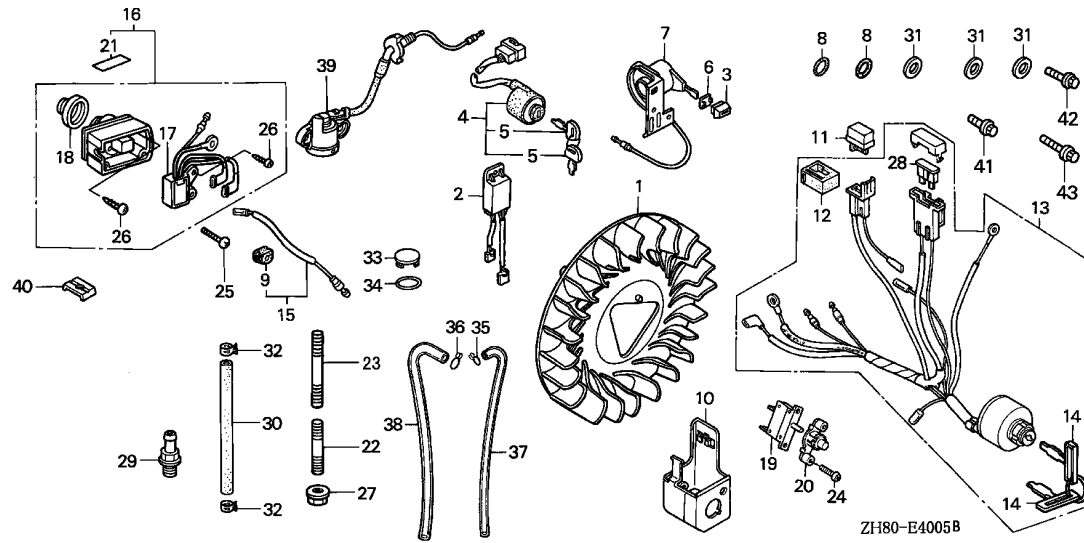

Ref. No.	Part No.	Description	Reqd. QTY				Serial No.	Parts catalogue code
			(1)	(2)	(3)	(4)		

				GX160K1					
42	95701-06012-00	BOLT, FLANGE, 6X12	5	-	-	-	-----	VSG	
43	95701-06022-00	BOLT, FLANGE, 6X22	2	-	-	-	-----	VSG	

2

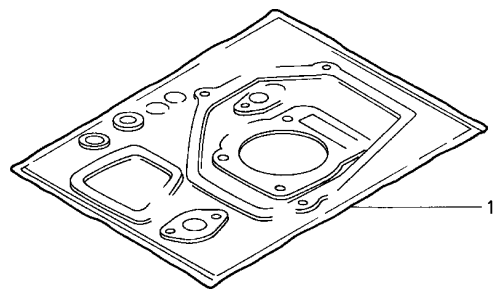

HENG-X0003

Ref. L.O.N. (Relative ref. Number) F.R.T.
No. Description

NO INFORMATION

Ref. No.	Part No.	Description	Reqd. QTY				Serial No.	Parts catalogue code
			(1)	(2)	(3)	(4)		
1	061A1-ZH8-020	GASKET KIT	1	-	-	-	EN,ET,ETX,HH,HHQ4,HX,HXU,HX4,KTA,LAX,LD,LD4,LH,LHQ4,LHW,LTA,LW2,LX,LXU,LX4,PH,PHU,PM,PM2,PX,PXU,QA,QD,QE,QFE4,QH,QHE,QHP1,QHQ4,QM,QNT,QNT4,QT,QWA4,QX,QXB,QXB1,QXE,QXE4,QXE8,QXU,QXW,QX4,QZ,RAC,RD,RD4,RH,RHQ4,RSK,RX,RXE,RXE4,RXU,RX4,SAC,SD,SDB1,SDS,SD4,SE,SEE,SH,SHQ4,SHR4,STA,SWX,SW2,SX,SXB,SXE,SXE4,SXU,SX4,THU,TH,TX,TXU,UX,UXU,VA,VEBM,VED,VED1,VED3,VH,VHQ4,VS,VSD,VSD1,VSX,VSX1,VS1,VS3,VS4,VX,VXE,VXE4,VXG,VXU,VXU1,VX4,WKT4	
			1	-	-	-	3413169 DS,DSP,EMA,HXQ,HX2,LJ,LJD,LJG,LJS,LMT,LSS,LTK,LX2,PX2,QA2,QXE2,QXF2,QXQ,QXS2,QX2,RH2,RMD,SCJ,SJ,SJG,SKM,SMJ,SMJ1,SNX,SSK1,ST,STM,STP,STQ,TX2,VXW2,VX2,WJP,WMT	
	061A1-ZH8-030	-	1	1	-	SNX1	
			1	-	-	-	3413170 EMA,HXQ,HX2,LX2,PX2,QA2,QXE2,QXF2,QXQ,QXS2,QX2,RH2,RMD,TX2,VED3,VXW2,VX2,WJP,WMT	
			1	-	-	-	3413170 3427858 DS,DSP,LJ,LJD,LJG,LJS,LMT,LSS,LTK,SCJ,SJ,SJG,SKM,SMJ,SMJ1,SNX,SSK1,ST,STA,STM,STP,STQ	
	061A1-ZH8-040	1	1	-	-	3427859 DS,DSP,LJ,LJD,LJG,LJS,LMT,LSS,LTK,L1,Q1,RMD,R1,SCJ,SJ,SJG,SKM,SMJ,SMJ1,SNX,SSK1,ST,STA,STM,STP,STQ,S1,T1,V1,WJP,WMT,W1	
			1	-	-	1	EMA2,HG12,HXE,HXE8,LAX2,LDB1,LDB3,LDM,LJC7,LSJ,LSJ4,LSS1,LSS4,NJ,NJC1,NJG,NSJ,NW,PHM,QAB1,QAB3,QAX2,QBT2,QBU2,QGR9,QMC6,QMC8,QMD6,QMH,QMX2,QMZ2,QNT2,QP,QSC2,QSC9,QWX2,QXC9,QXM1,QXW2,RFR2,RHA2,RMB4,RMG2,RNG,RTB2,SAD2,SDB3,SDN,SDS2,SG24,SHM,SJC,SJC1,SJC5,SMB4,SMC7,SMC9,SMW2,SSK2,SSX2,SWG4,SXS4,TCS2,TCX9,VA2,VEB2,VED2,VED5,VGE4,VG24,VMB3,VMS4,VPM4,VPR4,VS1,VSDP,VSU,VSX3,VTD,VTD1,VTE2,VTX,VTX1,VWA2,VW12,VXD,VXD1,VXE6,VXM,VXP,WKT2,WMB0,WME2,WME4	
	061A1-ZH8-801	1	-	-	-	3413169 HG1,HX,QA,QAX,QX,QXC,QXE,QXF,QXS,RFR,RH,RHA,TX,VWA,VX,VXW,VXW1	
	061A1-ZH8-802	1	-	-	-	3413170 HG1,HX,QA,QAX,QX,QXC,QXE,QXF,QXS,RFR,RH,RHA,TX,VWA,VX,VXW,VXW1	
	06111-ZK8-V00	1	-	-	-	AR,KR	

2

PART NO. INDEX

2-J 3

Part Number	Address	Page	Ref.	Part Number	Address	Page	Ref.	Part Number	Address	Page	Ref.	Part Number	Address	Page	Ref.
16953-883-691	2-C12	227	7		N13	196	6		2-C8	223	20	17670-ZH8-D01	2-C10	225	24
16953-ZE1-811	M2	169	26	17233-896-701	2-B3	202	1		2-C14	229	15	17672-880-000	2-C6	221	26
16953-ZE1-812	K13	148	23		2-B11	210	1	17510-ZE1-020ZG	2-C5	220	6		2-C10	225	25
	L2	153	23	17235-ZE1-831	N3	186	6		2-C8	223	20		2-C16	231	24
	M2	169	26	17238-ZE7-010	N4	187	7		2-C14	229	15	17672-887-791	2-D7	238	8
16954-ZE1-811	M2	169	27		N9	192	4	17510-ZE1-020ZJ	2-C8	223	20	17672-ZE2-W00	2-C9	224	24
16954-ZE1-812	K14	149	24		N11	194	2	17510-ZE1-020ZK	2-C14	229	15		2-C16	231	23
	L2	153	24		N13	196	7	17510-ZE1-020ZL	2-C14	229	15	17672-ZE2-W01	2-C6	221	9
	M3	170	27		2-B1	200	5	17510-ZE1-020ZM	2-C8	223	20		2-C10	225	24
16954-ZF0-841	M2	169	27	17239-733-000	N13	196	8	17510-ZF1-T00ZA	2-C14	229	15		2-C16	231	23
16955-ZE1-000	2-C5	220	5	17239-ZB2-000	N16	199	5	17520-ZA0-800	2-D8	239	14		2-D6	237	12
	2-C8	223	17	17239-ZE1-000	N4	187	8	17620-890-010	2-C8	223	22	17673-893-000	2-C6	221	27
	2-C13	228	8		N10	193	5		2-C14	229	16		2-C10	225	26
	2-D7	238	2		N11	194	3		2-D5	236	8		2-C16	231	25
16956-ZA0-010	2-B8	239	9		2-B1	200	6	17620-899-013	2-C15	230	18		2-D6	237	13
16956-ZE1-811	K14	149	25	17251-ZE0-S10	2-B1	200	7		2-D8	239	15	17682-817-020	2-D7	238	9
	L2	153	25	17252-ZB2-000	N16	199	6	17620-Z0T-814	2-C5	220	7		2-C16	231	26
	M4	171	28	17255-758-000	2-B1	200	8		2-C8	223	21				
16957-ZE1-812	K14	149	26	17401-ZE1-810	N11	194	4		2-C15	230	17	18000			
	L2	153	26	17402-ZE1-810	N11	194	5		2-D6	237	23				
	M4	171	29	17403-ZE1-810	N11	194	6		2-D7	238	4	18310-734-750	2-C2	217	1
16958-397-771	2-C13	228	9	17404-841-000	N12	195	7	17620-ZE2-W00	2-C6	221	28	18310-ZK8-870	2-B3	202	2
16959-471-831	2-C13	228	10	17410-ZE1-020	N4	187	9		2-C9	224	22	18310-ZB2-000	2-B14	213	1
16963-191-005	2-B8	239	10		N10	193	6		2-C14	229	16	18310-ZB3-C00	2-B14	213	1
16967-GA6-671	2-C13	228	11		N12	195	8		2-D7	238	5	18310-ZB6-C01	2-C4	219	1
16967-MA2-771	2-D8	239	11	17410-ZE1-840	N13	196	9	17620-ZE2-W11	2-C14	229	16	18310-ZE1-821	2-B4	203	2
16967-ZE0-811	L2	153	27	17410-ZE1-P30	2-B1	200	9	17620-ZH7-013	2-C5	220	7		2-B11	210	2
	M5	172	30	17421-ZE1-000	N10	193	7		2-C8	223	21	18310-ZE1-900	2-B3	202	2
					N12	195	9		2-C14	229	17	18310-ZE1-S40	2-C3	218	1
17000				17470-ZE1-841	N13	196	10		2-D5	236	7	18310-ZF1-000	2-B4	203	2
				17470-ZE1-842	N13	196	10		2-D7	238	4		2-B11	210	2
17200-ZK7-V01	2-B1	200	1	17475-ZE1-841	N13	196	11	17620-ZH7-023	2-C5	220	7	18310-ZH7-V90	2-B3	202	2
17201-ZF1-900	N15	198	1	17476-ZE1-841	N13	196	12		2-C8	223	21	18310-ZH8-810	2-B3	202	2
17210-883-903	2-B2	201	1	17478-ZE1-841	N13	196	13		2-C14	229	17		2-B11	210	2
17210-ZE1-822	N2	185	2	17500-ZE1-813ZA	2-C8	223	18		2-D5	236	7	18310-ZH8-T30	2-B4	203	2
	N13	196	2		2-C13	228	12		2-D7	238	4	18310-ZK7-V01	2-B16	215	1
17210-ZK7-V01	2-B1	200	2	17505-898-023	2-D8	239	12	17624-187-020	2-D8	239	16	18310-ZK8-V50	2-B4	203	2
17211-ZB2-000	N16	199	1	17505-ZB2-003	2-C13	228	13	17631-329-003	2-C5	220	8	18310-ZL0-W80	2-C1	216	1
17211-ZE1-000	N9	192	1		2-D5	236	5		2-C9	224	23	18311-ZE1-S40	2-C3	218	2
17212-ZB2-000	N16	199	2	17505-ZE1-013	2-C8	223	19		2-C16	231	20	18312-734-000	2-C2	217	2
17212-ZE1-000	N9	192	2		2-C13	228	13		2-D6	237	10	18313-734-000	2-C2	217	3
17216-PM4-300	2-B1	200	14	17507-ZA0-800	2-I3	314	33		2-D7	238	6	18315-ZE1-000	2-B10	209	27
17217-PM4-300	2-B1	200	15	17510-734-701ZA	2-D7	238	3	17631-899-000	2-C16	231	21		2-B11	210	3
17218-883-901	2-B2	201	2	17510-ZB2-000ZA	2-D5	236	6		2-D8	239	17	18315-ZE1-S40	2-C3	218	3
17218-ZE1-821	N2	185	3	17510-ZB2-000ZB	2-D5	236	6	17631-Z0T-812	2-C6	221	8	18316-ZE1-S40	2-C3	218	4
	N13	196	3	17510-ZB2-000ZG	2-D5	236	6		2-C9	224	23	18317-ZE1-S40	2-C3	218	5
17218-ZK7-V01	2-B1	200	3	17510-ZB2-000ZH	2-D5	236	6		2-C16	231	19	18320-ZB2-000	2-B14	213	2
17219-733-010	N13	196	4	17510-ZB2-000ZL	2-D5	236	6		2-D6	237	24	18320-ZE1-000	2-B4	203	3
17220-ZB2-000	N16	199	3	17510-ZB2-000ZM	2-D5	236	6		2-D7	238	6	18320-ZE1-T02	2-B5	204	3
17220-ZB6-601	2-B2	201	3	17510-ZB4-000ZA	2-C13	228	14	17631-ZH7-003	2-C6	221	8	18320-ZF1-H00	2-B4	203	3
17230-ZB6-000	2-B2	201	4	17510-ZB4-000ZB	2-C13	228	14		2-C9	224	23	18320-ZF1-H01	2-B5	204	3
17230-ZE1-820	N2	185	4	17510-ZB4-000ZH	2-C13	228	14		2-C15	230	19		2-B11	210	4
	N14	197	20	17510-ZB6-010	2-D8	239	13		2-D6	237	9	18320-ZF1-H51	2-B5	204	3
17230-ZE1-841	N13	196	5	17510-ZE1-020ZA	2-C5	220	6		2-D7	238	6		2-B11	210	4
17230-ZK7-V01	2-B1	200	4		2-C8	223	20	17670-899-000	2-C16	231	22	18321-ZF1-910	2-B13	212	1
17231-ZB2-000	N16	199	4		2-C14	229	15	17670-ZB2-000	2-D6	237	11	18321-ZH8-000	2-B4	203	3
17231-ZE1-000	N9	192	3	17510-ZE1-020ZB	2-C8	223	20	17670-ZB6-000	2-D8	239	18	18325-ZE1-S40	2-C3	218	6
17232-890-010	2-B2	201	5		2-C14	229	15	17670-ZH7-A21	2-D6	237	12	18325-ZB2-000	2-B14	213	3
17232-891-000	N3	186	5	17510-ZE1-020ZF	2-C5	220	6	17670-ZH7-A81	2-D7	238	7	18325-ZE1-010	2-B5	204	4

3

PART NO. INDEX

2-J 7

Part Number	Address	Page	Ref.	Part Number	Address	Page	Ref.	Part Number	Address	Page	Ref.	Part Number	Address	Page	Ref.
93892-05020-08	2-E6	253	43		2-G8	287	13		2-D4	235	50	95701-08016-00	2-H13	308	35
93893-05016-00	2-F10	273	28		2-H13	308	28		2-D8	239	22	95701-08020-00	2-B16	215	8
93901-22320	2-I3	314	26	94301-10160	F5	60	12	95002-35000	2-I3	314	35				
				94303-08140	H3	90	9	95002-40800-08	K15	150	36	98079-56846	F7	62	15
94000					2-G12	291	10		M11	178	40		2-H11	306	5
				94305-20122	K14	149	31		M14	181	24	98079-56854	F8	63	15
94001-04390-0S	2-F16	279	24		L2	153	32	95002-41200-08	2-I3	314	32	98079-56855	F8	63	15
	2-G5	284	24		M7	174	35	95002-45000	2-I3	314	36	98200-30500	2-E6	253	45
94001-08000-0S	2-B9	208	22		M14	181	18	95002-50000	2-C6	221	17		2-G1	280	27
	2-B12	211	21		M15	182	10		2-C11	226	42		2-G5	284	26
	2-B13	212	3	94305-20182	M16	183	21		2-D4	235	51		2-I3	314	28
	2-B15	214	11	94510-22000	2-H15	310	10	95002-80000	F5	60	13		2-G1	280	27
	2-B16	215	4	94510-25000	2-H14	309	20	95003-05021-31	2-I3	314	37		2-G1	280	27
	2-C1	216	3	94520-50000	2-H15	310	11	95003-09025-31	2-I3	314	38		2-I3	314	28
	2-C2	217	6	94520-52000	2-H13	308	29	95005-35130-10	H3	90	11		2-G1	280	27
	2-C3	218	10	94608-50000	H2	89	20	95014-62100	2-H11	306	3	95701-08032-08	2-G11	290	10
	2-C4	219	6					95700-06020-00	N14	197	19	95701-08035-00	2-G11	290	11
94050-05000	2-I1	312	27	95000				95700-06050-00	J15	134	16		2-G12	291	11
94050-06000	N8	191	15					95700-06055-00	2-G10	289	29	95701-08045-00	2-H15	310	12
	N10	193	12	95001-45025-40	2-D2	233	36	95700-08022-00	2-G10	289	30	95701-08055-00	2-G12	291	12
	N12	195	14	95001-45035-40	2-D4	235	48	95700-08032-08	2-G11	290	10	95701-08115-00	2-H15	310	13
	N14	197	18	95001-45040-40	2-C10	225	34	95700-08035-00	2-G11	290	11	95701-08150-00	2-H13	308	37
	N15	198	2	95001-45080-40	2-D8	239	19	95701-06008-00	G6	77	24	95701-10160-00	2-H13	308	38
	2-B1	200	11	95001-45095-40	2-C6	221	25		J12	131	13	95723-08060-00	F5	60	14
	2-B2	201	7		2-C10	225	35		J14	133	16	95801-06028-00	2-I1	312	30
	2-B15	214	12		2-D6	237	20		J15	134	17	95801-08020-18	2-B15	214	15
	2-B16	215	5	95001-45110-40	2-D4	235	49		K8	143	20		2-H11	306	9
	2-C6	221	13	95001-45140-40	2-C6	221	14		K9	144	21	95900-06012-00	2-B12	211	13
	2-C10	225	33		2-C10	225	36						2-C6	221	18
	2-D2	233	34		2-D2	233	37						2-C11	226	43
	2-D7	238	11		2-D7	238	12	95701-06010-00	N16	199	9		2-D3	234	40
	2-F11	274	29	95001-45150-40	2-D6	237	20		K8	143	21		2-D7	238	14
	2-F14	277	18		2-H13	308	30		N16	199	9	96000			
94050-06080	N16	199	8	95001-45180-40	2-C10	225	35		2-F16	279	26				
94050-10000	G4	75	19		2-C11	226	37		2-G5	284	25	96100-60040-00	2-H14	309	21
	2-H13	308	25		2-D2	233	38	95701-06012-00	2-I3	314	41	96100-60050-00	2-G12	291	13
	2-I3	314	27	95001-45240-40	2-C11	226	38		G6	77	22	96100-62030-00	2-H14	309	22
94101-04800	2-G1	280	29	95001-45250-40	2-D6	237	20		H4	91	8		2-H15	310	14
	2-G5	284	29	95001-45260-40	2-D6	237	20		2-B10	209	31	96100-62040-00	2-G11	290	12
94101-06800	G4	75	20	95001-45300-40	M11	178	39		2-B12	211	13	96100-62050-00	G1	72	16
	M16	183	20		2-D2	233	37						H1	88	12
94103-05700	2-B9	208	23		2-D8	239	20		2-B15	214	13		H3	90	13
	2-B12	211	22	95001-45350-40	2-D2	233	37	95701-06016-00	2-I4	315	42		H4	91	10
94109-12000	2-G10	289	26	95001-45400-60	K15	150	35		2-B1	200	12		2-G8	287	14
	2-G11	290	9		M11	178	39		2-B16	215	6		2-G10	289	31
	2-H13	308	26		M14	181	23	95701-06020-00	N7	190	14		2-H14	309	23
94111-04800	2-F16	279	25	95001-45430-40	2-D2	233	37		N10	193	11	96100-62060-00	2-G10	289	32
	2-G1	280	30	95001-45770-40	2-C11	226	39		N12	195	13	96100-63050-00	2-G11	290	13
	2-G5	284	30	95002-02070	H3	90	10		N14	197	19				
94111-05800	2-F14	277	19	95002-02080	M11	178	40		2-B1	200	13	98000			
94111-08000	2-G10	289	27		2-D6	237	22		2-D6	237	22				
94201-20120	2-H13	308	27		2-C6	221	15	95701-06022-00	2-I4	315	43	98079-54841	F5	60	15
94201-20200	2-I1	312	28		2-C11	226	40	95701-06025-00	2-B16	215	7	98079-54846	F5	60	15
94251-08000	G5	76	21		2-D3	234	39		2-C6	221	18	98079-54854	F5	60	15
	2-D2	233	35		2-D6	237	21		2-C11	226	43	98079-54855	F5	60	15
94301-08100	2-E6	253	44		2-D7	238	13		2-D4	235	40	98079-55841	F5	60	15
	2-G10	289	28		2-D8	239	21	95701-06032-00	2-H13	308	32	98079-55846	F6	61	15
	G16	87	10	95002-02100	2-H13	308	31	95701-06040-00	2-H13	308	33	98079-55854	F6	61	15
94301-08140	H4	91	7		2-C6	221	16	95701-06055-00	2-G10	289	29	98079-55855	F6	61	15
					2-C11	226	41	95701-08012-00	2-H13	308	34	98079-56841	F6	61	15

3

PART NO. INDEX

2-J 8

Part Number	Address	Page	Ref.	Part Number	Address	Page	Ref.	Part Number	Address	Page	Ref.	Part Number	Address	Page	Ref.
99101-ZH8-0680	M10	177	36												
	M14	181	19												
	M16	183	22												
99101-ZH8-0700	K15	150	32												
	M10	177	36												
	M14	181	19												
	M16	183	22												
99101-ZH8-0720	M10	177	36												
	M14	181	19												
99101-ZH8-0750	M14	181	19												
99204-ZE0-0350	K15	150	33												
	M11	178	37												
	M14	181	20												
	M15	182	11												
	M16	183	23												
99204-ZE0-0380	K15	150	33												
	L2	153	34												
	M10	177	37												
	M14	181	20												
99204-ZE0-0400	M10	177	37												
99204-ZE2-0380	K15	150	33												
	M10	177	37												
	M14	181	20												

3

PART NAME INDEX

2-K 1

Part name	Address	Page	Ref.	Part name	Address	Page	Ref.	Part name	Address	Page	Ref.
[A]											
ALERT UNIT, OIL	G6	77	23	BEARING, RADIAL BALL, 6305	2-G11	290	13	BOLT, FLANGE, 6X25	2-B16	215	7
	J16	135	1	BODY, CLEANER	N11	194	4		2-C6	221	18
			2	BODY, OIL CAP	2-H16	311	15		2-C11	226	43
	K9	144	23	BOLT-WASHER, 6X20	N6	189	14		2-D3	234	40
	2-G1	280	28		N10	193	11		2-D4	235	40
	2-G2	281	1		N12	195	13		2-D7	238	14
	2-G5	284	28	BOLT-WASHER, 8X16	2-C3	218	8		2-D15	246	14
ARM COMP., GOVERNOR	2-E12	259	4	BOLT, 3X12	2-H11	306	2	BOLT, FLANGE, 6X28	2-E5	252	35
	2-F12	275	33	BOLT, AIR CLEANER COVER	2-B2	201	6		2-D15	246	12
ARM COMP., L. SIDE CLUTCH	2-H12	307	12	BOLT, ALTERNATOR	2-H12	307	16		2-F16	279	26
ARM COMP., R. SIDE CLUTCH	2-H12	307	11	BOLT, BREATHING	2-G11	290	6		2-G5	284	25
ARM, BRAKE	2-H16	311	10	BOLT, CONNECTING ROD	I14	117	5		2-G7	286	6
ARM, GOVERNOR	2-E11	258	4	BOLT, DRAIN PLUG	F16	71	12	BOLT, FLANGE, 6X29	2-I1	312	30
	2-E12	259	4	BOLT, DRAIN PLUG, 12MM	2-G10	289	25		2-C6	221	18
	2-F14	277	3		2-H12	307	24		2-C11	226	43
ARM, VALVE ROCKER	I16	119	3	BOLT, DRAIN PLUG, 12X15	2-G11	290	7		2-D4	235	40
ARRESTER, SPARK	2-B6	205	6	BOLT, FLANGE, 10X125	2-H13	308	37	BOLT, FLANGE, 6X32	2-E4	251	32
	2-B11	210	6	BOLT, FLANGE, 10X160	2-H13	308	38		2-H13	308	32
	2-B14	213	7	BOLT, FLANGE, 5X10	2-D15	246	13	BOLT, FLANGE, 6X40	2-H13	308	33
				BOLT, FLANGE, 6X10	J12	131	13	BOLT, FLANGE, 6X50	J15	134	16
					J14	133	16	BOLT, FLANGE, 6X55	2-G10	289	29
					J15	134	17	BOLT, FLANGE, 6X8	G6	77	24
					K8	143	21		J12	131	13
					N16	199	9		J14	133	16
					2-F16	279	26		J15	134	17
					2-G5	284	25		K8	143	20
					2-I3	314	41		K9	144	21
				BOLT, FLANGE, 6X12	F4	59	9				24
					G6	77	22		N16	199	9
					H4	91	8	BOLT, FLANGE, 8X115	2-H15	310	13
					K8	143	17	BOLT, FLANGE, 8X12	2-H13	308	34
					2-B10	209	31	BOLT, FLANGE, 8X16	2-H13	308	35
					2-B12	211	13	BOLT, FLANGE, 8X20	2-B15	214	15
							23		2-B16	215	8
					2-B15	214	13		2-C3	218	11
					2-F6	269	21		2-H11	306	4
					2-F14	277	13				9
					2-H12	307	14		2-I1	312	29
					2-I4	315	42	BOLT, FLANGE, 8X22	2-G10	289	30
				BOLT, FLANGE, 6X13	F4	59	9		2-G13	292	15
					K7	142	17	BOLT, FLANGE, 8X30	2-H13	308	36
					2-B10	209	26	BOLT, FLANGE, 8X32	G16	87	11
							29		H3	90	12
					2-B12	211	13		H4	91	9
					2-F6	269	21		2-G11	290	10
				BOLT, FLANGE, 6X14	H3	90	6	BOLT, FLANGE, 8X35	2-G11	290	11
				BOLT, FLANGE, 6X16	H3	90	7		2-G12	291	11
					2-B1	200	12		2-G13	292	7
					2-B16	215	6				16
				BOLT, FLANGE, 6X20	K8	143	18	BOLT, FLANGE, 8X45	2-H15	310	12
					N7	190	14	BOLT, FLANGE, 8X55	2-G12	291	12
					N10	193	11	BOLT, FLANGE, 8X60	F5	60	14
					N12	195	13	BOLT, GOVERNOR ARM	2-F7	270	22
					N14	197	19		2-F14	277	14
					2-B1	200	13	BOLT, HEX., 5X28	2-I1	312	26
					2-D6	237	22	BOLT, HEX., 5/16"	H6	93	13
				BOLT, FLANGE, 6X22	2-I4	315	43	BOLT, HEX., 8X20	2-B14	213	10
				BOLT, FLANGE, 6X23	2-D15	246	12		2-C4	219	5
				BOLT, FLANGE, 6X25	K8	143	18	BOLT, HEX., 8X25	H6	93	13



PART NAME INDEX

2-K 2

Part name	Address	Page	Ref.	Part name	Address	Page	Ref.	Part name	Address	Page	Ref.
BOLT, HEX., 8X25	H7	94	2	CAP COMP., FUEL FILLER	2-D6	237	23	CHOKE SET	K12	147	9
	2-G8	287	12		2-D7	238	4		L9	160	10
	2-G12	291	9				5		M13	180	9
BOLT, HEX., 8X35	2-G10	289	24		2-D8	239	15		M15	182	1
BOLT, MUDGUARD	N14	197	16	CAP, CLEANER	N10	193	7		M16	183	8
BOLT, PIVOT, 8MM	J2	121	14		N12	195	9	CIRCLIP, 10.2MM	2-E5	252	37
BOLT, RECESSED, 5X16	2-F14	277	15	CAP, ENGINE KILL SWITCH	2-I2	313	18	CIRCLIP, 5MM	K14	149	27
BOLT, SETTING	2-E4	251	31	CAP, FUEL METER	2-I3	314	33		L2	153	28
BOLT, SPECIAL, 6X21	2-H12	307	15	CAP, LENS	2-E4	251	27		M5	172	31
BOLT, SPECIAL, 8MM	2-H14	309	14	CAP, MUFFLER	2-B6	205	5		M16	183	18
BOLT, STUD, 10X32	2-I3	314	22		2-B11	210	5		2-F9	272	26
BOLT, STUD, 10X60	2-I3	314	23	CAP, OIL	2-H12	307	8		2-F12	275	31
BOLT, STUD, 6X112	F4	59	10	CAP, OIL FILLER	G12	83	6	CIRCLIP, 7MM	2-G13	292	12
BOLT, STUD, 6X94	F4	59	10	CAP, PRE AIR CLEANER	N13	196	11	CIRCLIP, EXTERNAL, 22MM	2-H15	310	10
BOLT, STUD, 8X32	F5	60	11	CAP, REDUCTION OIL	2-G10	289	17	CIRCLIP, EXTERNAL, 25MM	2-H14	309	20
BOLT, WINKER SETTING	N16	199	7	CARBURETOR ASSY.	K12	147	10	CIRCLIP, INTERNAL, 47	2-G13	292	11
BOSS, GUIDE	2-H15	310	3		L1	152	9	CIRCLIP, INTERNAL, 50MM	2-H15	310	11
BOX ASSY., CONTROL	2-F15	278	3		L9	160	11	CIRCLIP, INTERNAL, 52MM	2-H13	308	29
	2-G2	281	3		L10	161	11	CLAMPER, CORD	K4	139	10
			4		L11	162	11		2-D14	245	6
	2-G3	282	4		M13	180	10	CLAMP D, 19MM	2-I1	312	25
BOX, TOOL	2-H8	303	1		M15	182	2	CLAMP, CORD	K4	139	10
BRACKET COMP., FR.	2-E3	250	15		M16	183	9	CLAMP, TUBE	K15	150	36
BRACKET, CASE MOUNTING	2-F15	278	5	CASE B, STARTER	J12	131	14		M11	178	40
	2-G3	282	6	CASE COMP., AIR CLEANER	N16	199	3		M14	181	24
	2-I2	313	10		2-B2	201	3		2-I3	314	32
BRACKET, MUFFLER	2-B15	214	14	CASE COMP., FUSE	2-E4	251	23	CLEANER ASSY., AIR	2-B1	200	1
BUSH, CONTROL KNOB	2-G6	285	3	CASE COMP., L. TRANSMISSION ...	2-H12	307	3	CLIP A, WIRE	2-B1	200	14
	2-I2	313	6	CASE COMP., RECOIL STARTER	J4	123	2	CLIP B, WIRE	2-B1	200	15
BUSH, FUEL PURGE	2-D8	239	8		J5	124	2	CLIP, CORD	2-F16	279	19
BUZZER ASSY.	K10	145	29		J12	131	17		2-G4	283	19
					J13	132	2	CLIP, DOUBLE	2-C6	221	11
[C]					J15	134	2		2-C10	225	30
CABLE, DOUBLE CONNECTOR	K9	144	22	CASE, CLUTCH	2-G13	292	2		2-D4	235	46
	2-D15	246	11	CASE, CONTROL	2-F15	278	4	CLIP, GOVERNOR HOLDER	F16	71	15
CAMSHAFT ASSY.	I15	118	1		2-G3	282	5	CLIP, HARNESS	K4	139	10
	I16	119	1		2-G6	285	1	CLIP, PISTON PIN, 18MM	I14	117	6
	J2	121	16	CASE, PRE AIR CLEANER	N13	196	10	CLIP, PURSE LOCK	K9	144	25
CAM, BRAKE	2-H16	311	8	CASE, RECOIL STARTER SPRING ...	J14	133	10		2-F16	279	18
CAP ASSY., NOISE SUPPRESSOR ..	2-D13	244	2		J15	134	10		2-G4	283	18
	2-D14	245	2	CASE, REDUCTION	2-G9	288	1	CLIP, SUB CORD	J12	131	15
CAP ASSY., OIL FILLER	G10	81	4		2-G11	290	1	CLIP, TUBE	F5	60	13
	G11	82	5	CASE, R. TRANSMISSION	2-H12	307	2		H3	90	10
	H2	89	15	CASE, SIDE CLUTCH BEARING	2-H14	309	9		M11	178	40
			16	CENTER, CLUTCH	2-G9	288	5		2-C6	221	15
	H3	90	4	CENTER, CLUTCH WEIGHT	2-G9	288	13				16
	H4	91	3	CHAIN, DRIVE	2-G10	289	15				17
CAP COMP., FUEL FILLER	2-C5	220	7	CHAIN, P.T.O. DRIVE	J2	121	17		2-C11	226	40
	2-C6	221	28		2-G7	286	3				41
	2-C8	223	21	CHAMBER SET, FLOAT	2-G12	291	3				42
			22		K11	146	5		2-D3	234	39
	2-C9	224	22		L1	152	5		2-D4	235	50
	2-C14	229	16		L5	156	5				51
			17		L6	157	5		2-D6	237	21
	2-C15	230	17		M12	179	4		2-D7	238	13
			18	CHOKE KIT, REMOTE CONTROL	M16	183	4		2-D8	239	21
	2-D5	236	7		K11	146	1				22
			8		L1	152	1		2-H13	308	31
					L3	154	1		2-I3	314	35

4

PART NAME INDEX

2-K 3

Part name	Address	Page	Ref.	Part name	Address	Page	Ref.	Part name	Address	Page	Ref.
CLIP, TUBE	2-I3	314	36	COVER ASSY., CRANKCASE	H4	91	1	DOWEL PIN, 8X14	G16	87	10
CLIP, VALVE GUIDE	F1	56	4	COVER COMP., AIR CLEANER	2-B1	200	4		H3	90	9
CLIP, WATER HOSE	2-C6	221	12		2-B2	201	4		H4	91	7
	2-C10	225	31	COVER COMP., FAN	K1	136	4		2-G8	287	13
	2-D4	235	47		K2	137	4		2-G12	291	10
COCK ASSY., FUEL	2-C6	221	21				5		2-H13	308	28
	2-C7	222	15				6	DRIVER 3, MINUS SCREW	2-H8	303	6
	2-C8	223	15		K10	145	26	DRUM COMP., BRAKE	2-H16	311	9
	2-C12	227	3	COVER COMP., GEAR	2-E1	248	4				
	2-D5	236	3	COVER COMP., HEAD	F2	57	6	[E]			
	2-D8	239	7	COVER COMP., MUFFLER	2-B6	205	9	ELBOW COMP., AIR CLEANER	N4	187	9
COIL ASSY., CHARGE	2-D14	245	8		2-B12	211	9		N10	193	6
	2-D15	246	9	COVER COMP., MUFFLER RR.	2-B7	206	10		N12	195	8
			10		2-B12	211	10		N13	196	9
COIL ASSY., IGNITION	2-D12	243	1	COVER, AIR CLEANER	N2	185	4		2-B1	200	9
	2-D13	244	1		N9	192	3	ELEMENT B, AIR CLEANER	2-B2	201	2
COIL ASSY., LAMP	2-D14	245	3		N13	196	5	ELEMENT COMP., AIR CLEANER	2-B1	200	2
			4		N14	197	20		2-B2	201	1
COIL ASSY., LAMP & CHARGE	2-D14	245	5		N16	199	4	ELEMENT, AIR CLEANER	N2	185	2
COLLAR B, AIR CLEANER	N4	187	8	COVER, BEVEL	2-H15	310	2		N9	192	1
	N10	193	5	COVER, CLUTCH	2-G13	292	1		N11	194	6
	N11	194	3	COVER, MAGNETIC SWITCH	2-E3	250	19		N13	196	2
	N13	196	8	COVER, REDUCTION	2-G9	288	3		N16	199	1
	2-B1	200	6		2-G11	290	3	EMBLEM	2-G14	293	2
COLLAR,	2-H14	309	18	COVER, SPRING	2-E2	249	13		2-G15	294	6
			19	COVER, STARTER MOTOR TERMINAL ..	2-E3	250	20		2-G16	295	6
COLLAR, AIR CLEANER	N4	187	7	CRANKSHAFT COMP.	H5	92	1		2-H1	296	6
	N9	192	4				2	EMBLEM, UPPER	2-H2	297	11
	N11	194	2				3	END, LOCK	2-F6	269	19
	N13	196	7				4				
	2-B1	200	5				5	[F]			
COLLAR, AIR CLEANER CASE	2-B3	202	1				6	FAN, COOLING	2-D9	240	1
	2-B11	210	1				7		2-I2	313	1
COLLAR, CONTROL BOX	2-D6	237	18				8	FAN, TRANSMISSION COOLING	2-H16	311	4
COLLAR, FUEL PUMP DISTANCE ...	2-C7	222	7				9	FILTER COMP., FUEL	2-C10	225	24
COLLAR, STOPPER	2-F6	269	18				10		2-C16	231	22
COLLAR, TANK CUSHION	2-D1	232	32				11		2-D6	237	11
CONNECTOR, SUCTION PORT	2-H16	311	16				12		2-D7	238	7
CONTROL ASSY.	2-E7	254	1				16	FILTER, CUP	2-C13	228	10
	2-E8	255	1				1	FILTER, FUEL	2-C6	221	9
			2	CUP, FUEL STRAINER	H7	94	1				26
	2-E9	256	2		L2	153	27		2-D7	238	7
	2-E10	257	3		M5	172	30		2-D8	239	18
	2-E14	261	8		2-C6	221	20		2-C13	228	10
	2-F14	277	2		2-C7	222	2		2-C6	221	9
CORD A, ENGINE STOP	K10	145	28		2-C13	228	11				24
CORD, ENGINE KILL SWITCH	2-I2	313	15		2-D5	236	2		2-C9	224	24
CORD, MAGNET SWITCH	2-E3	250	18		2-D8	239	11		2-C10	225	24
CORD, STOP SWITCH	K7	142	15								25
	2-D15	246	15	[D]					2-C16	231	23
	2-H14	309	2	DEFLECTOR COMP.	2-B6	205	5		2-D6	237	12
COUNTERSHAFT	2-E3	250	17		2-B10	209	28		2-D7	238	8
COUPLER COMP.	2-G7	286	1		2-H11	306	16	FILTER, OUTER	N2	185	3
COVER ASSY., CHAIN CASE	2-G12	291	1	DEFLECTOR, MUFFLER	2-B6	205	8		N13	196	3
	G7	78	1		2-B11	210	8		2-B1	200	3
COVER ASSY., CRANKCASE	G8	79	1	DISK, CLUTCH FRICTION	2-G9	288	6	FLOAT SET	K11	146	4
			2	DOWEL PIN, 10X16	F5	60	12		L1	152	4
	H1	88	13	DOWEL PIN, 8X10	2-E6	253	44		L4	155	4
	H3	90	1		2-G10	289	28		M12	179	3



PART NAME INDEX

Part name	Address	Page	Ref.	Part name	Address	Page	Ref.	Part name	Address	Page	Ref.
FLOAT SET	M16	183	3	GUIDE, IN. VALVE	F1	56	2	JET, MAIN,	K15	150	32
FLYWHEEL COMP.	2-D10	241	6	GUIDE, MUFFLER	2-B7	206	13		L2	153	33
					2-H11	306	17		M7	174	36
				GUIDE, PRE AIR CLEANER	N13	196	12		M8	175	36
	2-D11	242	9	GUIDE, RATCHET	J7	126	5		M9	176	36
FORK, SIDE CLUTCH	2-H12	307	9		J14	133	9		M10	177	36
FUSE, BLADE	2-E6	253	45		J15	134	9		M14	181	19
	2-G1	280	27						M16	183	22
	2-G5	284	26	[H]				JOINT, BREATHER	2-H12	307	1
	2-I3	314	28	HANDLE, BOX WRENCH	2-H9	304	12	JOINT, DRAIN	2-I3	314	29
[G]				HARNES ASSY., SUB WIRE	2-D16	247	17	JOINT, FUEL	2-C12	227	4
GASKET KIT	2-I5	316	1		2-F16	279	8	JOINT, FUEL TANK	2-C5	220	5
GASKET SET	K11	146	2						2-C8	223	17
	L1	152	2	HEAD COMP., CYLINDER	2-G5	284	27		2-C13	228	8
	L3	154	2	HOLDER, CABLE	F1	56	1	JOINT, ROD	2-D7	238	2
	M12	179	1		K13	148	22		2-F14	277	1
	M16	183	1		L2	153	22	[K]			
GASKET, CYLINDER HEAD	F1	56	5		M2	169	24	KEY ASSY., COMBINATION SWITCH ..	2-I2	313	5
GASKET, MUFFLER	2-B6	205	7		M16	183	17	KEY COMP.	2-E4	251	22
	2-B11	210	7		2-F2	265	12		2-F16	279	13
	2-B13	212	2		2-F14	277	8		2-G4	283	13
	2-B14	213	8	HOLDER, CLUTCH SPRING	2-I3	314	40		2-I2	313	14
				HOLDER, CLUTCH WEIGHT	2-G9	288	10	KEY, 4.78X4.78X38	H6	93	15
	2-B16	215	3	HOLDER, CONTROL CABLE	2-G9	288	12		2-G13	292	13
	2-C1	216	2		K13	148	17	KEY, 5MM	2-G10	289	20
	2-C2	217	4		L2	153	17	KEY, 5X5X21	2-H16	311	21
	2-C3	218	7	HOLDER, FUEL FILTER	L16	167	19	KEY, 5X5X33	H6	93	15
	2-C4	219	3		2-C6	221	27		H7	94	4
					2-C10	225	26	KEY, 7X7X33	2-G8	287	10
GAUGE ASSY., FUEL	2-C8	223	19		2-C16	231	25	KEY, SPECIAL WOODRUFF, 25X18 ..	2-G10	289	21
	2-C13	228	13	HOLDER, GOVERNOR WEIGHT	2-D6	237	13	KILL UNIT, ENGINE	2-D11	242	11
GAUGE ASSY., THICKNESS	2-H8	303	9	HOLDER, HARNES	2-D7	238	9	NOB, COCK LEVER	2-I2	313	17
GAUGE, OIL LEVEL	H2	89	19	HOLDER, LENS	F13	68	6		2-G6	285	2
	2-G10	289	18	HOLDER, WIRE	2-E5	252	38		2-I2	313	3
GEAR ASSY.	2-E3	250	14	H.S.T. ASSY.	2-E4	251	29	NOB, RECOIL STARTER	J14	133	14
GEAR, COUNTERSHAFT	2-H14	309	6		2-F6	269	17		J15	134	14
GEAR, DRIVEN	2-H14	309	7		2-F11	274	30	[L]			
GEAR, DRIVEN BEVEL	2-H14	309	12		2-H15	310	1	LABEL, AIR CLEANER CAUTION	2-H5	300	22
GEAR, FINAL	2-H14	309	10	[I]				LABEL, CAUTION	2-H6	301	33
GEAR, INPUT SHAFT CHANGE	2-H14	309	5	INSULATOR, CARBURETOR	K12	147	13		2-G14	293	3
GEAR, SIDE CLUTCH	2-H14	309	8		L2	153	13		2-H2	297	11
GEAR, SIDE CLUTCH DRIVE	2-H14	309	4		L14	165	15		2-H7	302	3
GOVERNOR ASSY.	F11	66	4		M14	181	13	LABEL, E-SPEC	2-H6	301	33
	F12	67	4		M15	182	4				
GRID, AIR CLEANER	N9	192	2		M16	183	12	LABEL, FUEL CAUTION	2-H6	301	29
	N12	195	7	[J]				LABEL, FUEL WARNING	2-H1	296	7
GRIP	2-H8	303	7	JET SET, PILOT,	K15	150	33	LABEL, SPECIFICATION	2-H4	299	17
GRIP, SCREW DRIVER	2-H8	303	7		L2	153	34	LENS	2-E4	251	26
GRIP, STARTER	J10	129	9		M10	177	37	LENS ASSY., PROTECTOR	2-E4	251	25
GROMMET, AIR CLEANER	N3	186	5		M11	178	37		2-F16	279	15
	N13	196	6		M14	181	20		2-G4	283	15
	2-B2	201	5		M15	182	11	LEVER COMP., CHOKE	2-I2	313	20
GROMMET, CORD	2-D14	245	7	JET, MAIN,	M16	183	23		K13	148	19
	2-I2	313	9		K14	149	32				
GROMMET, DRAIN HOLE	K7	142	16								
GUARD, MISSION	2-H12	307	7								
GUIDE, EX. VALVE	F1	56	3								

PART NAME INDEX

2-K 5

Part name	Address	Page	Ref.	Part name	Address	Page	Ref.	Part name	Address	Page	Ref.
LEVER COMP., CHOKE	K13	148	20	MARK, FUEL WARNING	2-H7	302	2	NUT, FLANGE, 6MM	N14	197	18
	L2	153	19	MARK, HEAT CAUTION	2-H7	302	11		N15	198	2
			20	MARK, OIL ALERT	2-G14	293	5		N16	199	8
	M1	168	21		2-H4	299	18		2-B1	200	11
			22				19		2-B2	201	7
	M14	181	17		2-H5	300	19		2-B15	214	12
			21		2-H6	301	32		2-B16	215	5
	M15	182	8				37		2-C6	221	13
LEVER COMP., CONTROL	2-E16	263	9				38		2-C10	225	33
LEVER, COCK	K13	148	23		2-H7	302	7		2-D2	233	34
	L2	153	23	MARK, OIL CAUTION	2-H6	301	30		2-D7	238	11
	M2	169	26	MARK, THROTTLE INDICATION	2-H5	300	20		2-F11	274	29
LEVER, CONTROL	2-E14	261	8	MARK, TOP	2-G14	293	3		2-F14	277	18
	2-E15	262	9		2-H2	297	11	NUT, HEX., 4MM	2-F16	279	24
	2-E16	263	9	MARK, USE FUEL	2-H7	302	12		2-G5	284	24
LEVER, FUEL COCK	2-D8	239	10	METER ASSY., FUEL	2-C13	228	13	NUT, HEX., 5MM	2-B8	207	20
LIFTER, VALVE	I16	119	4		2-D5	236	5		2-B12	211	19
				METER COMP., FUEL	2-D8	239	12	NUT, HEX., 8MM	2-B9	208	22
[M]				MOTOR ONLY	2-E2	249	9		2-B12	211	21
MARK A, COMBINATION	2-H2	297	11	MOTOR UNIT, STARTER	2-E1	248	3		2-B13	212	3
MARK B, COMBINATION	2-H2	297	8	MUFFLER COMP.	2-B3	202	2		2-B15	214	11
MARK, AIR CLEANER	2-H5	300	21		2-B4	203	2		2-B16	215	4
	2-H7	302	8		2-B11	210	2		2-C1	216	3
MARK, AIR CLEANER CAUTION	2-H2	297	10		2-B12	211	24		2-C2	217	6
MARK, AIR CLEANER SALES POINT	2-H5	300	23		2-B13	212	1		2-C3	218	10
MARK, CARBURETOR DRAIN	2-H6	301	34		2-B14	213	1		2-C4	219	6
MARK, CAUTION	2-G14	293	3		2-B16	215	1	NUT, LOCK, 24MM	2-G13	292	8
	2-H2	297	7		2-C2	217	1	NUT, PIVOT ADJUSTING	J2	121	15
			8		2-C3	218	1	NUT, SELF-LOCK, 6MM	2-F8	271	24
			9		2-C4	219	1	NUT, SPECIAL, 14MM	2-D11	242	10
	2-H6	301	29	[N]				NUT, TOOL BOX SETTING	N6	189	12
			35								13
	2-H7	302	1	NETTING, WIRE FLANGE	2-B10	209	32		N10	193	10
			4	NOSE, SILENCER	N3	186	6		N12	195	12
MARK, CHOKE	2-H2	297	12	NOZZLE, MAIN	K12	147	12		N14	197	17
			13		L1	152	11	NUT, WING, 6MM	N5	188	11
	2-H3	298	13		L12	163	13		N10	193	9
	2-H4	299	15		M13	180	12		N12	195	11
			16		M16	183	11		N14	197	15
	2-H7	302	5	NUT	J14	133	13				
			6		J15	134	13	[O]			
MARK, COCK	2-H4	299	14	NUT-WASHER, 6MM	2-E4	251	33	OIL SEAL	2-G10	289	22
MARK, CONTROL BOX	2-F16	279	16	NUT, AIR CLEANER COVER	N5	188	11		2-H12	307	22
	2-G4	283	16		N10	193	9	OIL SEAL, 12X25X7	2-H15	310	17
MARK, EMERGENCY SWITCH					N12	195	11	OIL SEAL, 15X24X7	2-H15	310	15
INDICATION	2-G14	293	4		N14	197	15	OIL SEAL, 15X35X7	2-H15	310	16
MARK, ENGINE KILL SWITCH	2-I2	313	21	NUT, CAP, 6MM	N4	187	10	OIL SEAL, 20X31X7	2-H14	309	17
MARK, ENGINE SWITCH	2-H5	300	19		N10	193	8	OIL SEAL, 25X38X7	2-G12	291	8
MARK, EX. CAUTION	2-H5	300	25		N12	195	10		G2	73	17
			26		N14	197	14		G14	85	9
	2-H7	302	9	NUT, CASTLE, 10MM	2-H16	311	18		G15	86	9
			10	NUT, FLANGE, 10MM	G4	75	19		H4	91	6
MARK, EX. GAS WARNING	2-H7	302	13		2-H13	308	25		2-G8	287	11
MARK, FIRE DANGER	2-H6	301	31		2-I3	314	27	O-RING	2-G11	290	8
MARK, FUEL	2-G14	293	3	NUT, FLANGE, 5MM	2-I1	312	27		2-C13	228	9
	2-H6	301	28	NUT, FLANGE, 6MM	N8	191	15		2-E1	248	2
			36		N10	193	12		2-E5	252	39
MARK, FUEL CAUTION	2-H1	296	7		N12	195	14				



PART NAME INDEX

2-K 6

Part name	Address	Page	Ref.	Part name	Address	Page	Ref.	Part name	Address	Page	Ref.
O-RING, 100X2	2-H16	311	24	PACKING, FUEL FILLER CAP	2-D8	239	17	PISTON	I12	115	2
O-RING, 14MM	G3	74	18	PACKING, FUEL STRAINER CUP	L2	153	12		I13	116	2
	2-C6	221	10		L13	164	14	PIVOT, ROCKER ARM	I16	119	5
	2-C10	225	29		2-C12	227	1	PLATE COMP., CLUTCH PRESSURE	2-G9	288	8
	2-D1	232	31		2-D8	239	2	PLATE COMP., DRIVE	2-G13	292	3
	2-D7	238	10	PACKING, HEAD COVER	F2	57	7	PLATE COMP., SIDE	K2	137	7
O-RING, 15.8X2.4	H3	90	8	PACKING, INSULATOR	K12	147	14	PLATE, BRAKE ARM SPRING	2-H16	311	13
O-RING, 16MM	2-H12	307	23		L2	153	14	PLATE, CLUTCH	2-G9	288	7
O-RING, 19.4X2.3	2-H16	311	23		L14	165	16	PLATE, EMBLEM	2-H1	296	6
O-RING, 23X2.8	H2	89	20		M14	181	14	PLATE, FRICTION	J13	132	6
O-RING, 26X2.7	2-G10	289	23		M15	182	5		J15	134	6
O-RING, 42.5X3	2-H15	310	8		M16	183	13	PLATE, FUEL INDICATION	2-H5	300	27
O-RING, 56X2.4	2-I3	314	34	PACKING, OIL FILLER CAP	G12	83	7		2-H7	302	14
O-RING, 5.5X1.4	2-C11	226	45					PLATE, GUARD	H4	91	5
	2-D4	235	53		G13	84	8	PLATE, LEVER SETTING	K14	149	24
O-RING, 64X2	2-H15	310	9		G14	85	8		L2	153	24
					H3	90	5		M2	169	27
[P]					H4	91	4		M3	170	27
PACKING C, FUEL METER	2-D8	239	16	PACKING, REDUCTION CASE	2-G9	288	2	PLATE, L. SIDE CLUTCH	2-H12	307	6
PACKING SET, COCK	2-C6	221	19		2-G11	290	2	PLATE, PRE AIR CLEANER	N13	196	13
	2-C7	222	1	PACKING, REDUCTION COVER	2-G9	288	4	PLATE, PUSH ROD GUIDE	J2	121	13
	2-D5	236	1		2-G11	290	4	PLATE, R. SIDE CLUTCH	2-H12	307	5
PACKING, AIR CLEANER	L15	166	17	PACKING, TRANSMISSION CASE	2-H12	307	4	PLATE, SIDE	K2	137	7
	M14	181	16	PANEL ASSY., BRAKE	2-H16	311	6		K3	138	7
	M16	183	16	PANEL COMP., BRAKE	2-H16	311	5		K4	139	7
PACKING, AIR CLEANER COVER	N13	196	4	PANEL COMP., CONTROL	2-F15	278	6				9
PACKING, CARBURETOR	K13	148	16		2-G3	282	7	PLIERS, 135	2-H10	305	16
	L2	153	16	PANEL, CONTROL BOX	2-F16	279	16	PLUG, SEALING, 28	2-H14	309	16
	L15	166	18		2-G4	283	16	PLUG, SPARK	F5	60	15
	L16	167	18	PAN, CLEANER OIL	N11	194	5		F6	61	15
	M14	181	15	PIECE A, STOPPER	2-E2	249	10		F7	62	15
	M15	182	7	PIECE B, STOPPER	2-E2	249	11		F8	63	15
	M16	183	14	PINION ASSY.	2-E2	249	5		2-H11	306	5
PACKING, CASE COVER	G8	79	3	PINION, BEVEL	2-H15	310	5	PROTECTOR, CIRCUIT	2-E4	251	24
	G9	80	3	PIN, AUXILIARY CHANGE LEVER	2-H12	307	20		2-F16	279	14
	G10	81	3	PIN, FORK	2-H12	307	10		2-G4	283	14
	H3	90	2	PIN, GOVERNOR WEIGHT	F14	69	7		2-I2	313	19
	H4	91	2	PIN, LOCK, 8MM	G5	76	21	PROTECTOR, EX. PIPE	2-C3	218	5
PACKING, CHAIN CASE	2-G7	286	2		2-D2	233	35				6
PACKING, CHAIN CASE COVER	2-G7	286	2	PIN, PISTON	I13	116	3	PROTECTOR, LOWER	2-B5	204	4
	2-G12	291	2	PIN, SPLIT, 2.0X12	2-H13	308	27	PROTECTOR, L. MUFFLER	2-C2	217	2
PACKING, ELBOW	N1	184	1	PIN, SPLIT, 2.0X20	2-I1	312	28	PROTECTOR, MUFFLER	2-B4	203	3
	N11	194	1	PIN, SPRING, 2X12	K14	149	31		2-B5	204	3
	N13	196	1		L2	153	32		2-B11	210	4
PACKING, FUEL COCK	K14	149	26		M7	174	35		2-C3	218	2
	L2	153	26		M14	181	18	PROTECTOR, MUFFLER INNER	2-B14	213	3
	M4	171	29	PIN, SPRING, 2X18	M15	182	10	PROTECTOR, MUFFLER OUTER	2-B14	213	2
PACKING, FUEL FILLER CAP	2-C5	220	8	PIN, STARTER RATCHET	M16	183	21	PROTECTOR, OIL TUBE	2-H16	311	2
	2-C6	221	8		J13	132	5	PROTECTOR, R. MUFFLER	2-C2	217	3
	2-C9	224	23	PIPE COMP., AIR INTAKE	J15	134	5	PROTECTOR, UPPER	2-B4	203	3
	2-C15	230	19	PIPE COMP., EX.	N15	198	1		2-B5	204	3
	2-C16	231	19		2-B14	213	5	PULLEY COMP., STARTER	2-D9	240	2
			20	PIPE, EX.	2-C4	219	2	PULLEY, DRIVE	2-H16	311	3
			21	PIPE, OIL FILLER	2-C1	216	1	PULLEY, RECOIL STARTER	J13	132	3
	2-D6	237	9		H2	89	18		J15	134	3
			10	PISTON	I8	111	2	PULLEY, STARTER	2-D10	241	3
			24		I9	112	2				5
	2-D7	238	6		I10	113	2	PUMP ASSY., FUEL	2-C7	222	5
					I11	114	2				

PART NAME INDEX

2-K 7

Part name	Address	Page	Ref.	Part name	Address	Page	Ref.	Part name	Address	Page	Ref.
[R]											
RATCHET, STARTER	J6	125	4	RUBBER, RR. BOTTOM	F15	70	11	SCREW, PAN, 3X12	2-G4	283	22
	J13	132	4	RUBBER, SUPPORTER	K15	150	34		2-I3	314	24
	J15	134	4		M11	178	38	SCREW, PAN, 3X6	K14	149	28
RECTIFIER ASSY., REGULATOR ...	2-D16	247	16		M14	181	22		L2	153	29
	2-F15	278	2		2-C5	220	3		M6	173	32
RECTIFIER ASSY., SILICON	2-E3	250	16		2-C7	222	10	SCREW, PAN, 3X8	K14	149	28
	2-F15	278	7						L2	153	29
	2-G3	282	8		2-C12	227	2		M6	173	32
	2-I2	313	11		2-D4	235	43	SCREW, PAN, 4X12	2-F16	279	23
RECTIFIER COMP., REGULATOR ...	2-F15	278	1	RUBBER, TANK CUSHION	2-D7	238	1		2-G4	283	23
	2-G2	281	2		2-D8	239	4	SCREW, PAN, 4X20	2-B1	200	10
	2-I2	313	2	RUBBER, TANK MOUNTING	2-C16	231	26		2-F14	277	16
REEL, RECOIL STARTER	J6	125	3					SCREW, PAN, 4X6	2-F10	273	27
RETAINER, EX. VALVE SPRING ...	J2	121	11		2-C6	221	23		2-F12	275	32
RETAINER, IN. VALVE SPRING ...	J2	121	10		2-C10	225	27	SCREW, PAN, 4X8	K14	149	29
					2-D4	235	54		L2	153	30
					2-D6	237	14		M6	173	33
									M16	183	19
RING SET, PISTON	H8	95	1	[S]				SCREW, PAN, 5X16	2-F10	273	28
	H9	96	1	SCREEN SET	2-C6	221	22		2-I3	314	25
	H10	97	1		2-C8	223	16	SCREW, PAN, 5X20	2-F8	271	25
	H11	98	1		2-C12	227	6		2-F14	277	17
	H12	99	1		2-D5	236	4	SCREW, PAN, 5X25	2-F8	271	25
	H13	100	1	SCREEN, FUEL STRAINER	2-C12	227	5	SCREW, PAN, 5X32	2-F9	272	25
	H14	101	1	SCREW-WASHER, 5X14	2-E6	253	42	SCREW, PAN, 5X35	K8	143	19
	H15	102	1	SCREW-WASHER, 5X16	2-F10	273	28		2-F9	272	25
	H16	103	1	SCREW-WASHER, 5X20	2-E6	253	43	SCREW, PAN, 5X40	K8	143	19
	I1	104	1	SCREW-WASHER, 5X30	2-E4	251	34		2-F9	272	25
	I2	105	1	SCREW-WASHER, 5X30	2-E4	251	34	SCREW, PAN, 5X8	K14	149	30
	I3	106	1	SCREW-WASHER, 5X8	2-E4	251	30		L2	153	31
	I4	107	1	SCREW-WASHER, 6X20	2-B8	207	21		M6	173	34
	I5	108	1		2-B12	211	20	SCREW, PAN, 6X6	2-C2	217	5
	I6	109	1	SCREW-WASHER, 6X40	2-G6	285	5		2-C3	218	9
	I7	110	1	SCREW SET	K12	147	8		2-F12	275	32
	I8	111	1		L1	152	8	SCREW, RECESSED, 5X25	2-F8	271	23
RING, SEAL	2-I2	313	8		L7	158	7	SCREW, SETTING	J11	130	12
ROD ASSY., CONNECTING	I13	116	4		L8	159	9	SCREW, SPECIAL, 6X12	2-F16	279	17
	I14	117	4		M13	180	8		2-G4	283	17
ROD COMP., THROTTLE	M2	169	25		M16	183	7	SCREW, TAPPING, 3X12	2-I3	314	26
ROD, CHOKE	2-F14	277	12	SCREW SET, DRAIN	K12	147	7	SCREW, TAPPING, 4X6	2-B8	207	17
ROD, GOVERNOR	2-E12	259	5		L1	152	7				
	2-F14	277	4		L8	159	8		2-B10	209	24
ROD, PUSH	I16	119	2		M12	179	7				
ROPE, RECOIL STARTER	J10	129	10		M16	183	6		2-B12	211	17
	J11	130	11	SCREW SET, PILOT	K11	146	6				
	J14	133	15		K16	151	37				
	J15	134	15		L1	152	6	SCREW, TAPPING, 4X8	2-B8	207	18
	J12	131	18		L6	157	6		2-B10	209	30
ROPE, STARTER	J2	121	12		L7	158	7		2-H11	306	18
ROTATOR, VALVE	2-E2	249	8		M12	179	5	SCREW, TAPPING, 5X25	2-B8	207	16
ROTOR ASSY.	F16	71	11						2-B12	211	16
RUBBER, BOTTOM	2-G13	292	5		M16	183	5	SCREW, TAPPING, 5X8	2-B8	207	14
RUBBER, CLUTCH DAMPER	2-D6	237	16	SCREW, FLAT, 5X10	2-C10	225	32				
RUBBER, CONTROL BOX	F15	70	10		2-D1	232	33		2-B12	211	14
RUBBER, FR. BOTTOM	2-C6	221	24		2-D6	237	19				
RUBBER, FUEL	2-C10	225	28	SCREW, FLAT, 6X10	2-C10	225	32	SCREW, THROTTLE STOP	K12	147	11
	2-C16	231	30	SCREW, LOCK PAN	2-F8	271	25		L1	152	10
	2-D6	237	17	SCREW, OVAL, 4X32	2-D8	239	1		L12	163	12
RUBBER, FUEL PUMP MOUNTING ...	2-C7	222	6	SCREW, PAN, 3X12	2-F16	279	22		M13	180	11

4

PART NAME INDEX

2-K 8

Part name	Address	Page	Ref.	Part name	Address	Page	Ref.	Part name	Address	Page	Ref.
SCREW, THROTTLE STOP	M15	182	3	SPRING, FRICTION	J13	132	7	SWITCH ASSY., COMBINATION.....	2-E4	251	21
	M16	183	10		J15	134	7		2-F16	279	12
SEAL, AIR CLEANER	N16	199	6	SPRING, GOVERNOR	2-E13	260	6		2-G4	283	12
SEAL, BRAKE CAM	2-H16	311	22		2-E14	261	6		2-I2	313	4
SEAL, FUEL FILLER NECK	2-D8	239	14		2-F14	277	5				13
SEAL, MUFFLER PROTECTOR	2-B14	213	4		2-H11	306	15	SWITCH ASSY., ENGINE.....	2-G6	285	4
SEAL, VALVE STEM	J2	121	18	SPRING, LEVER	2-F1	264	10		2-I2	313	7
SEPARATOR, AIR CLEANER	N16	199	2	SPRING, RECOIL STARTER	J8	127	7	SWITCH ASSY., ENGINE STOP.....	K6	141	14
SEPARATOR, MUFFLER	2-C3	218	3		J14	133	8		K10	145	31
SHAFT COMP., P.T.O.	2-G10	289	16		J15	134	8		2-H11	306	1
	2-G13	292	6	SPRING, RETURN	J9	128	8	SWITCH ASSY., OIL LEVEL.....	F11	66	3
SHAFT UNIT, GEAR	2-E2	249	6		K13	148	21		2-I3	314	39
SHAFT, GOVERNOR ARM	F15	70	9		L2	153	21	SWITCH ASSY., ONE PUSH KILL...	2-I2	313	16
SHAFT, INPUT	2-H14	309	1		M1	168	23	SWITCH ASSY., STARTER MAGNETIC	2-E1	248	1
SHAFT, JOINT	2-H15	310	4		2-E2	249	12	SWITCH COMP., STARTING MAGNET	2-E1	248	1
SHAFT, P.T.O.	2-G7	286	5	SPRING, SIDE CLUTCH	2-H14	309	11				
	2-G8	287	15	SPRING, THROTTLE RETURN	2-E14	261	7	[T]			
	2-G11	290	5		2-F14	277	6	TANK ASSY., FUEL.....	2-C8	223	18
	2-G12	291	5	SPRING, THRUST	2-G8	287	7		2-C13	228	12
SHAFT, SCREW DRIVER	2-H8	303	6		2-G12	291	6	TANK ASSY., OIL.....	H3	90	3
SHAFT, SIDE CLUTCH	2-H14	309	3	SPRING, VALVE	J2	121	9		2-H16	311	14
SHAFT, SIDE CLUTCH ARM	2-H12	307	13	SPRING, WEIGHT RETURN	I16	119	6	TANK COMP., FUEL.....	2-C5	220	6
SHAFT, SUB	J14	133	12	SPROCKET COMP., DRIVE	2-G10	289	14		2-C8	223	20
	J15	134	12	SPROCKET, DRIVE	2-G7	286	4		2-C13	228	14
SHAFT, WHEEL	2-H14	309	13		2-G12	291	4		2-C14	229	15
SHOE COMP., BRAKE	2-H16	311	7	STARTER ASSY., RECOIL	J3	122	1		2-D5	236	6
SHROUD ASSY., UPPER	K5	140	12		J4	123	1		2-D7	238	3
	K6	141	12		J12	131	16		2-D8	239	13
	K10	145	27		J13	132	1	TERMINAL ASSY., HIGH TENSION..	2-D13	244	2
SHROUD COMP.	K5	140	11		J15	134	1	TOOL KIT.....	2-H8	303	2
SHROUD COMP., LOWER	K5	140	11	STAY COMP., CHOKE	M16	183	15		2-H10	305	18
SLIDER, GOVERNOR	F14	69	8	STAY COMP., FUEL COCK	2-D8	239	9				19
SPACER COMP., CARBURETOR	K13	148	15	STAY COMP., MUFFLER	2-B16	215	2	TUBE.....	2-C5	220	2
	L2	153	15	STAY, AIR CLEANER	N16	199	5		2-C7	222	4
	L15	166	17	STAY, CHOKE CONTROL	K13	148	18		2-D4	235	42
	M15	182	6		L2	153	18	TUBE A, AIR VENT.....	2-C5	220	1
SPACER, 20MM	2-G8	287	8		L16	167	20		2-C7	222	3
SPACER, CONTROL LEVER	2-F3	266	13	STAY, MUFFLER	2-B10	209	27		2-D4	235	41
SPACER, MUFFLER COVER	2-B7	206	12		2-B11	210	3	TUBE A, FUEL.....	2-C7	222	8
	2-B12	211	12		2-B14	213	6	TUBE B, FUEL.....	2-C7	222	9
SPANNER, 10X12	2-H10	305	13		2-C3	218	4	TUBE, 3.5X130.....	H3	90	11
SPANNER, 10X14	2-H10	305	14	STRAINER COMP., FUEL	2-C5	220	4	TUBE, AIR CLEANER CONNECTING..	2-B1	200	7
SPANNER, 14X17	2-H10	305	15		2-C7	222	12	TUBE, BREATHER	F3	58	8
SPRING, BRAKE ARM	2-H16	311	11					TUBE, DRAIN.....	2-I3	314	30
SPRING, BRAKE SHOE	2-H16	311	12		2-D4	235	44	TUBE, FASTENER, 30MM.....	2-F16	279	21
SPRING, CABLE RETURN	2-F5	268	16						2-G4	283	21
	2-F14	277	10	STRAINER, FUEL	2-D8	239	5		2-D8	239	3
			11		2-C7	222	12	TUBE, FUEL TANK	2-D4	235	49
SPRING, CLUTCH	2-G13	292	4		2-C12	227	7	TUBE, FUEL, 4.5X110.....	2-C6	221	14
SPRING, CLUTCH FREE	2-G9	288	9	STRAP, WIRE HARNESS, 25MM.....	2-F16	279	20		2-C10	225	36
SPRING, COCK LEVER	K14	149	25		2-G4	283	20		2-D2	233	37
	L2	153	25	SUB HARNESS	K6	141	13		2-D7	238	12
	M4	171	28		2-G4	283	10	TUBE, FUEL, 4.5X150.....	2-D6	237	20
SPRING, COIL	2-E4	251	28	SUSPENSION, AUDIBLE PILOT	K10	145	30		2-H13	308	30
SPRING, CONTROL ADJUSTING	J16	135	3	SUSPENSION, COUPLER	2-F16	279	10	TUBE, FUEL, 4.5X180.....	2-C10	225	35
	2-F4	267	15		2-G3	282	9		2-C11	226	37
	2-F14	277	7		2-I2	313	12		2-D2	233	38
			9	SUSPENSION, STRAINER	2-C7	222	14		2-C11	226	38
SPRING, FRICTION	J8	127	6		2-D8	239	6	TUBE, FUEL, 4.5X240.....	2-C11	226	38

4

PART NAME INDEX

2-K 9

Part name	Address	Page	Ref.	Part name	Address	Page	Ref.	Part name	Address	Page	Ref.
TUBE, FUEL, 4.5X25	2-D2	233	36	WASHER, DRAIN PLUG, 12MM	2-H13	308	26				
TUBE, FUEL, 4.5X250	2-D6	237	20	WASHER, PINION	2-E5	252	36				
TUBE, FUEL, 4.5X260	2-D6	237	20	WASHER, PLAIN, 4MM	2-G1	280	29				
TUBE, FUEL, 4.5X300	M11	178	39		2-G5	284	29				
	2-D2	233	37	WASHER, PLAIN, 5MM	2-B9	208	23				
	2-D8	239	20		2-B12	211	22				
TUBE, FUEL, 4.5X35	2-D4	235	48	WASHER, PLAIN, 6MM	G4	75	20				
TUBE, FUEL, 4.5X350	2-D2	233	37		M16	183	20				
TUBE, FUEL, 4.5X40	2-C10	225	34	WASHER, SEALING, 8MM	2-H12	307	19				
TUBE, FUEL, 4.5X400	K15	150	35	WASHER, SPECIAL	2-E6	253	40				
	M11	178	39	WASHER, SPRING	2-E6	253	41				
	M14	181	23	WASHER, SPRING, 4MM	2-F16	279	25				
TUBE, FUEL, 4.5X430	2-D2	233	37		2-G1	280	30				
TUBE, FUEL, 4.5X770	2-C11	226	39		2-G5	284	30				
TUBE, FUEL, 4.5X80	2-D8	239	19	WASHER, SPRING, 5MM	2-F14	277	19				
TUBE, FUEL, 4.5X95	2-C6	221	25	WASHER, SPRING, 8MM	2-G10	289	27				
	2-C10	225	35	WASHER, STARTER	J14	133	11				
	2-D6	237	20		J15	134	11				
TUBE, OIL	2-H16	311	1	WASHER, TANK CUSHION	2-C16	231	27				
TUBE, VINYL, 3.5X6.5X210	2-I3	314	37	WASHER, THRUST, 20MM	2-G10	289	19				
TUBE, VINYL, 4.5X8X250	2-I3	314	38	WASHER, THRUST, 6MM	F16	71	13				
[V]				WATER SEAL, 25X52X9.5	2-H12	307	21				
VALVE SET, FLOAT	K11	146	3	WEIGHT SET, CLUTCH	2-G13	292	17				
	L1	152	3	WEIGHT, CLUTCH	2-G9	288	11				
	L4	155	3	WEIGHT, GOVERNOR	F12	67	5				
	M12	179	2	WIRE, LOCK	2-F6	269	20				
	M16	183	2	WRENCH COMP., SPARK PLUG	2-H9	304	11				
VALVE, DASHPOT CHECK	M15	182	9	WRENCH, BOX	2-H8	303	10				
VALVE, EX.	I16	119	8		2-H9	304	11				
	J1	120	8	WRENCH, PLUG	2-H8	303	11				
	J2	121	8		2-H9	304	11				
VALVE, IN.	I16	119	7	[Y]							
[W]				YOKE ASSY.	2-E2	249	7				
WASHER, 10MM	2-H12	307	17								
	2-H16	311	17								
WASHER, 10.5MM	2-H16	311	20								
WASHER, 6.5X25X1.5	2-C11	226	44								
	2-D4	235	52								
WASHER, 8MM	H6	93	14								
	H7	94	3								
	2-G8	287	9								
	2-G12	291	7								
	2-G13	292	10								
	2-H16	311	19								
WASHER, 9X16X1.4	2-G13	292	9								
WASHER, AIR DUCT	2-C16	231	28								
	2-D6	237	15								
WASHER, BEVEL GEAR	2-H15	310	6								
WASHER, CLUTCH SPRING	2-H14	309	15								
WASHER, CONICAL SPRING, 6MM ..	2-H12	307	18								
WASHER, CONTROL LEVER	2-F2	265	11								
WASHER, DRAIN PLUG, 10.2MM ...	F16	71	14								
	2-I3	314	31								
WASHER, DRAIN PLUG, 12MM	2-G10	289	26								
	2-G11	290	9								

1

FOREWORD INDEX

2

ENGINE GROUP

3

PART NUMBER INDEX

4

PART NAME INDEX

HONDA
The Power of Dreams



PARTS CATALOGUE NEWS

Honda Motor Co., Ltd. Service Division

PARTS CATALOGUE - CORRECTED

Printed in Japan

CODE NO.	BOOKLET TYPE	13ZH81E0
	MICRO- FICHE	13ZH80EJ/FJ
PARTS CATALOGUE NEWS	GX160K1 GX160K1[PROPANE ENGINE]	
NEWS NO.	001	

Block No.	Ref. No.	Note	Part No.	Description	Reqd. QTY				Serial No.	Parts catalogue code
					(1)	GX160K1 (2)	(3)	(4)		
E-11-2	1	L	28400-734-003ZA	STARTER ASSY., RECOIL *R8*..... BRIGHT RED	1	-	-	-	----- 8364201	LJS
		D	28400-734-013ZF	*R280*..... POWER RED	1	-	-	-	8364202 -----	LJS
	2	L	28410-734-000ZA	CASE COMP., RECOIL STARTER *R8*..... BRIGHT RED	1	-	-	-	----- 8364201	LJS
		D	28410-734-000ZG	*R280*..... POWER RED	1	-	-	-	8364202 -----	LJS

NOTE A:PART NO. CHANGE D:NEWLY PROVIDED E:PART NO.DELETION K:REQUIRED NO. CORRECTION L:APPLICATION SERIAL NO. CORRECTION
T:APPLICATION CORRECTION Z:REMARKS CHANGE



PARTS CATALOGUE NEWS

Honda Motor Co., Ltd. Service Division

PARTS CATALOGUE - CORRECTED

Printed in Japan

CODE NO.	BOOKLET TYPE	13ZH81E0
	MICRO-FICHE	13ZH80EJ/FJ
PARTS CATALOGUE NEWS	GX160K1 GX160K1[PROPANE ENGINE]	
NEWS NO.	002	

Block No.	Ref. No.	Note	Part No.	Description	Reqd. QTY	Serial No.	Parts catalogue code
					(1) (2) (3) (4)		

E-17 FUEL TANK (1)

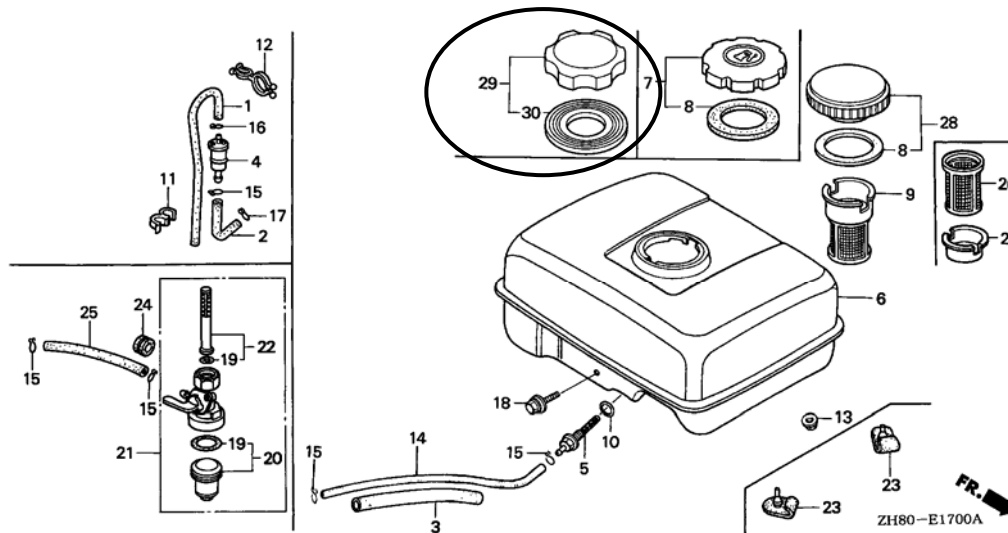

E-17 7 E 17620-Z0T-814 *PARTS NO. DELETION

NOTE A:PART NO. CHANGE D:NEWLY PROVIDED E:PART NO. DELETION K:REQUIRED NO. CORRECTION L:APPLICATION SERIAL NO. CORRECTION
T:APPLICATION CORRECTION Z:REMARKS CHANGE

PARTS CATALOGUE NEWS

BOOKNo. : 13ZH81E0

Block No.	Ref. No.	Note	Part No.	Description	Reqd. QTY				Serial No.	Parts catalogue code
					(1)	(2)	(3)	(4)		
	8	E	17631-Z0T-812	*PARTS NO. DELETION						
	29	T	17620-Z0T-814	CAP COMP., FUEL FILLER (CHROME PLATED)	1	-	-	-	8542060	HX, QCB2, QGR9, Q12, QSC9, QWX2, QX, QXC, QXE, QX22, QX7, RH, RTB2, SG24, SM12, SSSX2, SWX2, SX7, TX, VG24, VMS7, VSD7, VX, VXE7, WME2
	30	T	17631-Z0T-812	PACKING, FUEL FILLER CAP (39X62X3)	1	-	-	-	8542060	HX, QCB2, QGR9, Q12, QSC9, QWX2, QX, QXC, QXE, QX22, QX7, RH, RTB2, SG24, SM12, SSSX2, SWX2, SX7, TX, VG24, VMS7, VSD7, VX, VXE7, WME2

E-17-1 FUEL TANK (2)

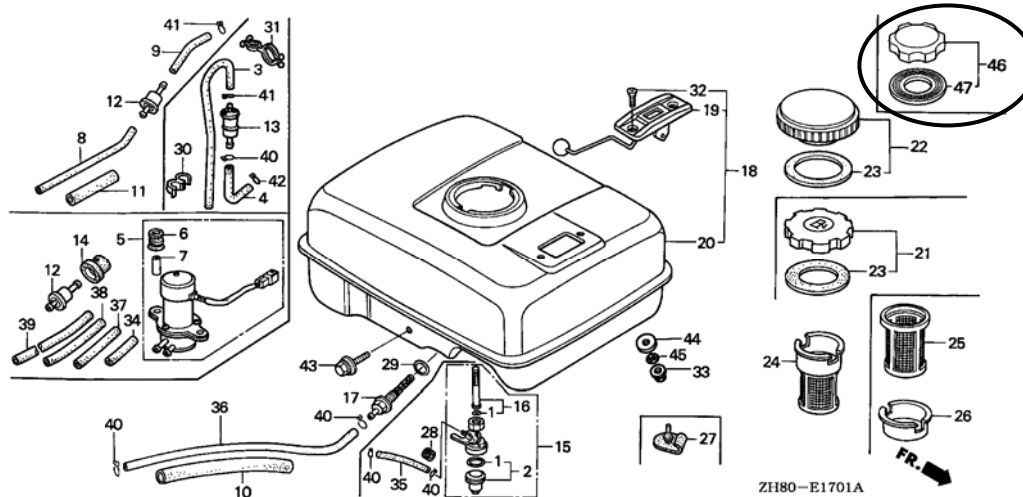

E-17-1	21	E	17620-Z0T-814	*PARTS NO. DELETION						
	23	E	17631-Z0T-812	*PARTS NO. DELETION						
	46	T	17620-Z0T-814	CAP COMP., FUEL FILLER (CHROME PLATED)	1	(1)	-	-	8542060	HG12, HX2, LJ, LJC7, LJG, LX2, L1, NJ, NJG, NSJ, QAX2, QA2, QGR2, QMX2, QM22, QSC2, QS2, QXC9, QXE2, QXF2, QXM1, QXS2, QX2, RH2, RMD, RSS1, RXE2, SCJ, SHRY, SJ, SJC1, SJC5, SJG, SMJ, SMJ1, SMW2, SM11, SNX, SNX1, SSK1, STQ, S1CY, TXC9, TX2, VA2, VED5, VWA2, VXD, VX2, WJP, WKT2, WMT

NOTE A:PART NO. CHANGE D:NEWLY PROVIDED E:PART NO.DELETION K:REQUIRED NO. CORRECTION L:APPLICATION SERIAL NO. CORRECTION
T:APPLICATION CORRECTION Z:REMARKS CHANGE

PARTS CATALOGUE NEWS

BOOKNo. : 13ZH81E0

Block No.	Ref. No.	Note	Part No.	Description	Reqd. QTY				Serial No.	Parts catalogue code
					(1)	GX160K1 (2)	(3)	(4)		
					1	-	-	-	8627839 -----	QBC2, VXD1
	47	T	17631-Z0T-812	PACKING, FUEL FILLER CAP (39X62X3)	1	(1)	-	-	8542060 -----	HG12, HX2, LJ, LJC7, LJG, LX2, L1, NJ, NJG, NSJ, QAX2, QA2, QGR2, QMX2, QMZ2, QSC2, QS2, QXC9, QXE2, QXF2, QXM1, QXS2, QX2, RH2, RMD, RSS1, RXE2, SCJ, SHRY, SJ, SJC1, SJC5, SJG, SMJ, SMJ1, SMW2, SM11, SNX, SNX1, SSK1, STQ, S1CY, TXC9, TX2, VA2, VED5, VWA2, VXD, VX2, WJP, WKT2, WMT
					1	-	-	-	8627839 -----	QBC2, VXD1

E-17-2 FUEL TANK (3)

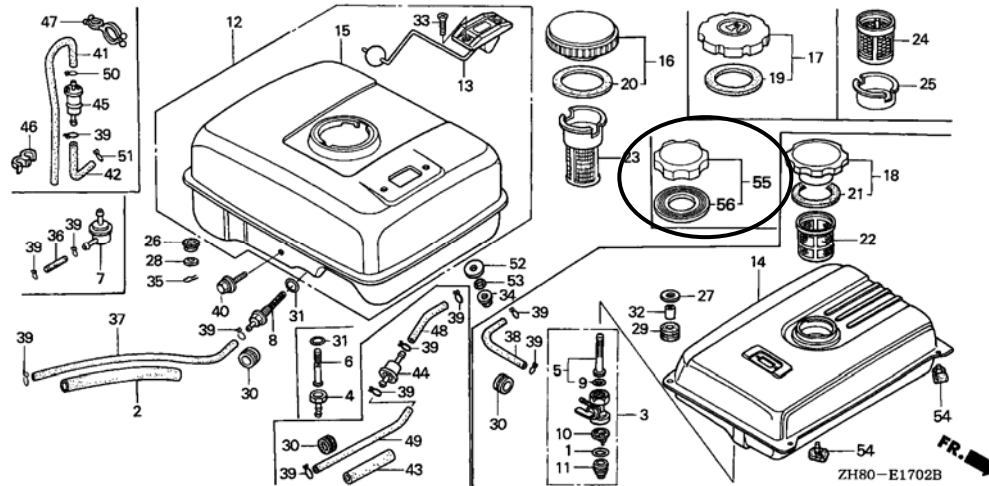

E-17-2	17	E	17620-Z0T-814	*PARTS NO. DELETION
	19	E	17631-Z0T-812	*PARTS NO. DELETION

NOTE A:PART NO. CHANGE D:NEWLY PROVIDED E:PART NO.DELETION K:REQUIRED NO. CORRECTION L:APPLICATION SERIAL NO. CORRECTION
T:APPLICATION CORRECTION Z:REMARKS CHANGE

PARTS CATALOGUE NEWS

BOOKNo. : 13ZH81E0

Block No.	Ref. No.	Note	Part No.	Description	Reqd. QTY				Serial No.	Parts catalogue code
					(1)	GX160K1 (2)	(3)	(4)		
55	T		17620-Z0T-814	CAP COMP., FUEL FILLER (CHROME PLATED)	1	(1)	-	-	8542060 -----	BL, HH, HHQ4, HH26, HXE2, HXE8, HXU, HX26, HX4, KTA, LD, LH, LHB3, LHQ4, LSJ4, LVL, LW2, LX, LXU, LX26, LX4, L1, PHM, PX, PXU, QAB3, QA26, QBT6, QD, QE, QFE4, QH, QHE, QHP1, QHQ4, QH26, QKA4, QMC6, QMC8, QMD6, QME4, QMH, QNT, QNT4, QNZ, QP, QPU, QT, QVL, QWA4, QXC6, QXE4, QXE6, QXE8, QXU, QXW, QX26, QX4, RD, RD4, RHQ4, RH26, RMB4, RSK, RX, RXE, RXE4, RXU, RX4, SD, SDS, SD16, SD4, SE, SH, SHM, SHQ4, SMC7, SMC9, SMX4, SM14, SWX4, SX, SXE, SXE4, SXS4, SXU, SX4, TXU, TX26, TX4, UXU, VEBM, VED, VED1, VED6, VMS4, VSD, VSX, VSX1, VSX3, VXE4, VXM, VXU, VXU1, VX4, WDA6, WKD6, WKT4, WKT6, WMBO, WME4
56	T		17631-Z0T-812	PACKING, FUEL FILLER CAP (39X62X3)	1	(1)	-	-	8542060 -----	BL, HH, HHQ4, HH26, HXE2, HXE8, HXU, HX26, HX4, KTA, LD, LH, LHB3, LHQ4, LSJ4, LVL, LW2, LX, LXU, LX26, LX4, L1, PHM, PX, PXU, QAB3, QA26, QBT6, QD, QE, QFE4, QH, QHE, QHP1, QHQ4, QH26, QKA4, QMC6, QMC8, QMD6, QME4, QMH, QNT, QNT4, QNZ, QP, QPU, QT, QVL, QWA4, QXC6, QXE4, QXE6, QXE8, QXU, QXW, QX26, QX4, RD, RD4, RHQ4, RH26, RMB4, RSK, RX, RXE, RXE4, RXU, RX4, SD, SDS, SD16, SD4, SE, SH, SHM, SHQ4, SMC7, SMC9, SMX4, SM14, SWX4, SX, SXE, SXE4, SXS4, SXU, SX4, TXU, TX26, TX4, UXU, VEBM, VED, VED1, VED6, VMS4, VSD, VSX, VSX1, VSX3, VXE4, VXM, VXU, VXU1, VX4, WDA6, WKD6, WKT4, WKT6, WMBO, WME4

E-17-4 FUEL TANK (5)

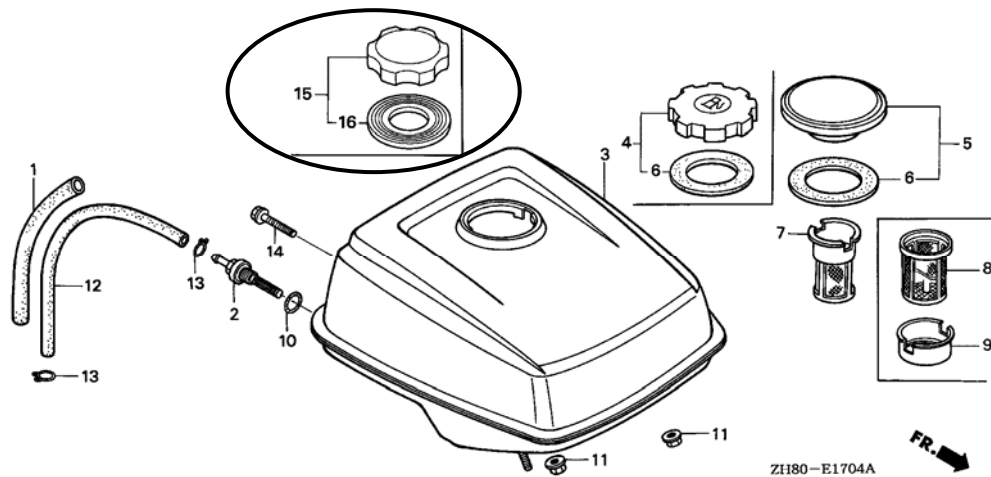

NOTE A:PART NO. CHANGE D:NEWLY PROVIDED E:PART NO.DELETION K:REQUIRED NO. CORRECTION L:APPLICATION SERIAL NO. CORRECTION
T:APPLICATION CORRECTION Z:REMARKS CHANGE

PARTS CATALOGUE NEWS

BOOKNo. : 13ZH81E0

Block No.	Ref. No.	Note	Part No.	Description	Reqd. QTY				Serial No.	Parts catalogue code
					(1)	GX160K1 (2)	(3)	(4)		
E-17-4	4	E	17620-Z0T-814	*PARTS NO. DELETION						
	6	E	17631-Z0T-812	*PARTS NO. DELETION						
	15	T	17620-Z0T-814	CAP COMP., FUEL FILLER (CHROME PLATED)	1	-	-	-	8542060 -----	LJS
	16	T	17631-Z0T-812	PACKING, FUEL FILLER CAP (39X62X3)	1	-	-	-	8542060 -----	LJS

NOTE A:PART NO. CHANGE D:NEWLY PROVIDED E:PART NO.DELETION K:REQUIRED NO. CORRECTION L:APPLICATION SERIAL NO. CORRECTION
T:APPLICATION CORRECTION Z:REMARKS CHANGE



PARTS CATALOGUE NEWS

Honda Motor Co., Ltd. Service Division

PARTS CATALOGUE - CORRECTED

Printed in Japan

CODE NO.	BOOKLET TYPE	13ZH81E0
	MICRO-FICHE	13ZH80EJ/FJ
PARTS CATALOGUE NEWS	GX160K1 GX160K1[PROPANE ENGINE]	
NEWS NO.	003	

Block No.	Ref. No.	Note	Part No.	Description	Reqd. QTY				Serial No.	Parts catalogue code
					(1)	GX160K1 (2)	(3)	(4)		
E-11	1	T	28400-ZH8-013ZA	STARTER ASSY., RECOIL *R8*..... BRIGHT RED	1	(1)	-	-	----- 8367072	HH26, HXE2, HXE8, HXU, HX26, LXU, LX26, L1, PXU, QA26, QBC2, QBT6, QH26, QWA4, QXC6, QXE6, QXE8, QXM1, QXU, QX26, QX7, RH26, RXU, SD16, SXU, SX7, TXU, TX26, UXU, VMS7, VPM7, VPR7, VSD7, VS17, VXE4, VXE7, VXU1, WKT6
					1	-	-	-	----- 2828660	HG1
					1	-	-	-	----- 5551817	SWG4
					1	-	-	-	----- 5641954	STM
					1	-	-	-	----- 6219318	QT

NOTE A:PART NO. CHANGE D:NEWLY PROVIDED E:PART NO.DELETION K:REQUIRED NO. CORRECTION L:APPLICATION SERIAL NO. CORRECTION
T:APPLICATION CORRECTION Z:REMARKS CHANGE

PARTS CATALOGUE NEWS

BOOKNo. : 13ZH81E0

Block No.	Ref. No.	Note	Part No.	Description	Reqd. QTY				Serial No.	Parts catalogue code
					(1)	GX160K1 (2)	(3)	(4)		
					1	-	-	-	----- 8366916	AR, ARC6, BL, HH, HHQ4, HX, HX2, HX4, KTA, LD, LH, LHB3, LHQ4 LJ, LJC7, LJG, LSJ4, LW2, LX, LX2, LX4, NJ, NJG, NSJ, PHM, PX QAB3, QAX2, QA2, QCB2, QCL, QD, QE, QFE4, QGR2, QGR9, QH, QHE QHP1, QHQ4, QI2, QKA4, QMC6, QMC8, QMD6, QME4, QMH, QMX2 QMZ2, QNT, QNT4, QNZ, QP, QPU, QSC2, QX, QXC, QXC9, QXE, QXE2 QXE4, QXF2, QXS2, QXW, QX2, QX22, QX4, RD, RD4, RH, RHA2 RHQ4, RH2, RMB4, RMD, RMG2, RSK, RSS1, RTB2, RX, RXE, RXE2 RXE4, RX4, SCJ, SD, SDS, SD4, SE, SG24, SH, SHM, SHQ4, SHRY SJ, SJC1, SJC5, SJG, SMC7, SMC9, SMJ, SMJ1, SMW2, SMX4, SM11 SM12, SM14, ST, STQ, SX, SXE, SXE4, SXS4, SX4, S1CY, TCS2, TX TXC9, TX2, TX4, VA2, VEBM, VED, VED1, VED2, VED3, VGE4, VG24 VHH4, VMS4, VMT, VPM4, VPR4, VSD, VSD1, VSX, VSX1, VSX3 VTU1, VX, VXM, VXU, VXW2, VX2, VX4, WDA6, WJP, WKD6, WKT2 WKT4, WMBO, WME2, WME4, WMT
					-	(1)	-	-	-----	H1, Q1, R1, S1, T1, U1, V1, W1
					-	-	-	1	----- 2000271	SXP1
		L	28400-ZH8-013YA	*R280*..... POWER RED	1	(1)	-	-	8367073 -----	HH26, HXE2, HXE8, HXU, HX26, LXU, LX26, L1, PXU, QA26, QBC2 QBT6, QH26, QWA4, QXC6, QXE6, QXE8, QXM1, QXU, QX26, QX7 RH26, RXU, SD16, SXU, SX7, TXU, TX26, UXU, VMS7, VPM7, VPR7 VSD7, VS17, VXE4, VXE7, VXU1, WKT6
					1	-	-	-	-----	KR, QS2, VES, VHA7, VPM5
					1	-	-	-	8366917 -----	AR, ARC6, BL, HH, HHQ4, HX, HX2, HX4, KTA, LD, LH, LHB3, LHQ4 LJ, LJC7, LJG, LSJ4, LW2, LX, LX2, LX4, NJ, NJG, NSJ, PHM, PX QAB3, QAX2, QA2, QCB2, QCL, QD, QE, QFE4, QGR2, QGR9, QH, QHE QHP1, QHQ4, QI2, QKA4, QMC6, QMC8, QMD6, QME4, QMH, QMX2 QMZ2, QNT, QNT4, QNZ, QP, QPU, QSC2, QX, QXC, QXC9, QXE, QXE2 QXE4, QXF2, QXS2, QXW, QX2, QX22, QX4, RD, RD4, RH, RHA2 RHQ4, RH2, RMB4, RMD, RMG2, RSK, RSS1, RTB2, RX, RXE, RXE2 RXE4, RX4, SCJ, SD, SDS, SD4, SE, SG24, SH, SHM, SHQ4, SHRY SJ, SJC1, SJC5, SJG, SMC7, SMC9, SMJ, SMJ1, SMW2, SMX4, SM11 SM12, SM14, ST, STQ, SX, SXE, SXE4, SXS4, SX4, S1CY, TCS2, TX TXC9, TX2, TX4, VA2, VEBM, VED, VED1, VED2, VED3, VGE4, VG24 VHH4, VMS4, VMT, VPM4, VPR4, VSD, VSD1, VSX, VSX1, VSX3 VTU1, VX, VXM, VXU, VXW2, VX2, VX4, WDA6, WJP, WKD6, WKT2 WKT4, WMBO, WME2, WME4, WMT
					-	-	-	1	2000272 -----	SXP1

NOTE A:PART NO. CHANGE D:NEWLY PROVIDED E:PART NO.DELETION K:REQUIRED NO. CORRECTION L:APPLICATION SERIAL NO. CORRECTION
T:APPLICATION CORRECTION Z:REMARKS CHANGE

PARTS CATALOGUE NEWS

BOOKNo. : 13ZH81E0

Block No.	Ref. No.	Note	Part No.	Description	Reqd. QTY				Serial No.	Parts catalogue code	
					(1)	(2)	(3)	(4)			
	2	L	28410-ZH8-003ZA	CASE COMP., RECOIL STARTER *R8*..... BRIGHT RED	1	(1)	-	1	-----	-----	DS, DSP, EN, ET, ETX, HG1, HXE, HXQ, H1, KR, LAX, LAX2, LDB1 LDB3, LDM, LD4, LHW, LJD, LSJ, LSS, LSS1, LSS4, LTA, LTK, NW PH, PHU, PM, PM2, PX2, QA, QAB1, QAX, QBU2, QM, QNT2, QXB QXB1, QXF, QXQ, QXS, QXW2, QZ, Q1, RAC, REX4, RFR, RFR2, RHA RNG, R1, SAC, SAD2, SDB1, SDB3, SDN, SDS2, SDS3, SEE, SHR4 SJC, SMB4, STA, STP, SWX, SW2, SXB, S1, TH, THU, T1, UH, UX, U1 VA, VEB2, VED5, VH, VHQ4, VMB3, VS, VSDP, VS1, VTD, VTE2, VWA VXE, VXE6, VXG, VXP, VXW, VX26, V1, W1
					1	(1)	-	-	-----	8367072	HH26, HXE2, HXE8, HXU, HX26, LXU, LX26, L1, PXU, QA26, QBC2 QBT6, QH26, QSC9, QWA4, QXC6, QXE4, QXE6, QXE8, QXM1, QXU QX26, QX7, RH26, RXE4, RXU, SD16, SXU, SX7, TXU, TX26, UXU VMS7, VPM7, VPR7, VSD7, VS17, VXE4, VXE7, VXU1, WKT6
					1	-	-	-	-----	5551817	SWG4
					1	-	-	-	-----	5641954	STM
					1	-	-	-	-----	6219318	QT
					1	-	-	-	-----	8366916	AR, ARC6, BL, HH, HHQ4, HX, HX2, HX4, KTA, LD, LH, LHB3 LHQ4, LJ, LJC7, LJG, LSJ4, LW2, LX, LX2, LX4, NJ, NJG, NSJ PHM, PX, QAB3, QAX2, QA2, QCB2, QCL, QD, QE, QFE4, QGR2, QGR9 QH, QHE, QHP1, QHQ4, QI2, QKA4, QMC6, QMC8, QMD6, QME4, QMH QMX2, QMZ2, QNT, QNT4, QNZ, QP, QPU, QSC2, QX, QXC, QXC9, QXE QXE2, QXF2, QXS2, QXW, QX2, QX22, QX4, RD, RD4, RH, RHA2 RHQ4, RH2, RMB4, RMD, RMG2, RSK, RSS1, RTB2, RX, RXE, RXE2 RX4, SCJ, SD, SDS, SD4, SE, SG24, SH, SHM, SHQ4, SHRY, SJ SJC1, SJC5, SJG, SMC7, SMC9, SMJ, SMJ1, SMW2, SMX4, SM11 SM12, SM14, SNX, SNX1, ST, STQ, SX, SXE, SXE4, SXS4, SX4 S1CY, TCS2, TX, TXC9, TX2, TX4, VA2, VEBM, VED, VED1, VED2 VED3, VGE4, VG24, VHH4, VMS4, VMT, VPM4, VPR4, VSD, VSD1 VSX, VSX1, VSX3, VTU1, VX, VXM, VXU, VXW2, VX2, VX4, WDA6 WJP, WKD6, WKT2, WKT4, WMBO, WME2, WME4, WMT
					-	-	1	-			
					-	-	-	1	-----	2000271	SXP1
		T	28410-ZH8-003YA	*R280*..... POWER RED	1	(1)	-	-	8367073	-----	HH26, HXE2, HXE8, HXU, HX26, LXU, LX26, L1, PXU, QA26, QBC2 QBT6, QH26, QSC9, QWA4, QXC6, QXE4, QXE6, QXE8, QXM1, QXU QX26, QX7, RH26, RXE4, RXU, SD16, SXU, SX7, TXU, TX26, UXU VMS7, VPM7, VPR7, VSD7, VS17, VXE4, VXE7, VXU1, WKT6
					1	-	-	-	-----	-----	QS2, VES, VHA7, VPM5

NOTE A:PART NO. CHANGE D:NEWLY PROVIDED E:PART NO. DELETION K:REQUIRED NO. CORRECTION L:APPLICATION SERIAL NO. CORRECTION
T:APPLICATION CORRECTION Z:REMARKS CHANGE

PARTS CATALOGUE NEWS

BOOKNo. : 13ZH81E0

Block No.	Ref. No.	Note	Part No.	Description	Reqd. QTY				Serial No.	Parts catalogue code	
					(1)	GX160K1 (2)	(3)	(4)			
					1	-	-	-	8366917	-----	AR, ARC6, BL, , HH, HHQ4, HX, HX2, HX4, KTA, LD, LH, LHB3 LHQ4, LJ, LJC7, LJG, LSJ4, LW2, LX, LX2, LX4, NJ, NJG, NSJ PHM, PX, QAB3, QAX2, QA2, QCB2, QCL, QD, QE, QFE4, QGR2, QGR9 QH, QHE, QHP1, QHQ4, QI2, QKA4, QMC6, QMC8, QMD6, QME4, QMH QMX2, QMZ2, QNT, QNT4, QNZ, QP, QPU, QSC2, QX, QXC, QXC9, QXE QXE2, QXF2, QXS2, QXW, QX2, QX22, QX4, RD, RD4, RH, RHA2 RHQ4, RH2, RMB4, RMD, RMG2, RSK, RSS1, RTB2, RX, RXE, RXE2 RX4, SCJ, SD, SDS, SD4, SE, SG24, SH, SHM, SHQ4, SHRY, SJ SJC1, SJC5, SJG, SMC7, SMC9, SMJ, SMJ1, SMW2, SMX4, SM11 SM12, SM14, SNX, SNX1, ST, STQ, SX, SXE, SXE4, SXS4, SX4 S1CY, TCS2, TX, TXC9, TX2, TX4, VA2, VEBM, VED, VED1, VED2 VED3, VGE4, VG24, VHH4, VMS4, VMT, VPM4, VPR4, VSD, VSD1 VSX, VSX1, VSX3, VTU1, VX, VXM, VXU, VXW2, VX2, VX4, WDA6 WJP, WKD6, WKT2, WKT4, WMBO, WME2, WME4, WMT
					-	-	-	1	2000272	-----	SXP1
E-12	6		19610-ZE1-820ZA	COVER COMP., FAN (STARTER MOTOR) *R8*..... BRIGHT RED	1	(1)	-	-	-----	-----	H1, LSS1, Q1, R1, S1, T1, U1, VSW, V1, W1
		A	19610-ZE1-820ZG	*R280*..... POWER RED	1	(1)	-	-	8366917	-----	L1, QNZ, SNX1, ST, STM, SWG4
E-28	6	L	87521-ZH8-020	EMBLEM (5.5)	1	(1)	-	-	7438468	8367036	AR, ARC6, HH, HHQ4, HH26, HX, HXE, HXE8, HXU, HX2, HX26, HX4 KR, KTA, LD, LH, LHB3, LHQ4, LJ, LJG, LSJ4, LW2, LX, LXU, LX2 LX26, LX4, L1, NJ, NJG, NSJ, PHM, PXU, QAB1, QAB3, QAX2, QA2 QA26, QBT6, QCB2, QCL, QD, QE, QFE4, QGR2, QGR9, QH, QHE QHP1, QHQ4, QH26, QKA4, QM, QMC6, QMC8, QMD6, QME4, QMH QMX2, QMZ2, QNT, QNT4, QNZ, QP, QPU, QSC9, QWA4, QWX2, QX QXC, QXC6, QXC9, QXE, QXE2, QXE4, QXE6, QXE8, QXF2, QXM1 QXS2, QXU, QXW, QXW2, QX2, QX22, QX26, QX4, Q1, RD, RD4, RH RHQ4, RH2, RH26, RMB4, RMD, RSK, RSS1, RTB2, RX, RXE, RXE4 RXU, RX4, SCJ, SD, SDB3, SDS, SD16, SD4, SE, SG24, SH, SHM SHQ4, SHRY, SHR4, SJ, SJC1, SJC5, SJG, SMC7, SMC9, SMJ, SMJ1 SMW2, SMX4, SM11, SM12, SM14, SSK1, SSX2, ST, STM, STQ, SWG4 SWX2, SWX4, SX, SXE, SXE4, SXS4, SXU, SX4, S1, S1CY, TCS2, TX TXU, TX2, TX26, TX4, UH, UX, UXU, VEBM, VED, VED1, VED2, VED3 VED5, VED6, VG24, VHH4, VMB3, VMS4, VMT, VPM4, VPR4, VSD VSD1, VSX, VSX1, VSX3, VTD, VTU1, VTX1, VW12, VX, VXD, VXE4 VXM, VXU, VXU1, VXW2, VX2, VX4, WDA6, WJP, WKD6, WKT4, WMBO WME2, WME4, WMT
					1	-	-	-	-----	8367036	QBC2, Q12, QX7, RXE2, SX7, VEN2, VMS7, VPM7, VPR7, VSD7 VS17, VXE7, WKT6
					1	-	-	-	-----	8382120	HXE2

NOTE A:PART NO. CHANGE D:NEWLY PROVIDED E:PART NO. DELETION K:REQUIRED NO. CORRECTION L:APPLICATION SERIAL NO. CORRECTION
T:APPLICATION CORRECTION Z:REMARKS CHANGE

PARTS CATALOGUE NEWS

BOOKNo. : 13ZH81E0

Block No.	Ref. No.	Note	Part No.	Description	Reqd. QTY				Serial No.		Parts catalogue code
					(1)	GX160K1 (2)	(3)	(4)			
					-	1	-	-	7438468	8367036	R1, W1
					-	-	1	-	-----	-----	QIH1, VIH1, WIH1
					-	-	-	1	2000208	2000271	SXP1
		T	87521-ZH8-030	1	(1)	-	-	8367037	-----	AR, ARC6, HH, HHQ4, HH26, HX, HXE, HXE8, HXU, HX2, HX26, HX4 KR, KTA, LD, LH, LHB3, LHQ4, LJ, LJG, LSJ4, LW2, LX, LXU, LX2 LX26, LX4, L1, NJ, NJG, NSJ, PHM, PXU, QAB1, QAB3, QAX2, QA2 QA26, QBC2, QBT6, QCB2, QCL, QD, QE, QFE4, QGR2, QGR9, QH QHE, QHP1, QHQ4, QH26, QI2, QKA4, QM, QMC6, QMC8, QMD6, QME4 QMH, QMX2, QMZ2, QNT, QNT4, QNZ, QP, QPU, QSC9, QWA4, QWX2 QX, QXC, QXC6, QXC9, QXE, QXE2, QXE4, QXE6, QXE8, QXF2, QXM1 QXS2, QXU, QXW, QXW2, QX2, QX22, QX26, QX4, QX7, Q1, RD, RD4 RH, RHQ4, RH2, RH26, RMB4, RMD, RSK, RSS1, RTB2, RX, RXE RXE2, RXE4, RXU, RX4, SCJ, SD, SDB3, SDS, SD16, SD4, SE, SG24 SH, SHM, SHQ4, SHRY, SHR4, SJ, SJC1, SJC5, SJG, SMC7, SMC9 SMJ, SMJ1, SMW2, SMX4, SM11, SM12, SM14, SSK1, SSS2, ST, STM STQ, SWG4, SWX2, SWX4, SX, SXE, SXE4, SXS4, SXU, SX4, SX7, S1 S1CY, TCS2, TX, TXU, TX2, TX26, TX4, UH, UX, UXU, VEBM, VED VED1, VED2, VED3, VED5, VED6, VEN2, VG24, VHH4, VMB3, VMS4 VMS7, VMT, VPM4, VPM7, VPR4, VPR7, VSD, VSD1, VSD7, VSX VSX1, VSX3, VS17, VTD, VTU1, VTX1, VW12, VX, VXD, VXE4, VXE7 VXM, VXU, VXU1, VXW2, VX2, VX4, WDA6, WJP, WKD6, WKT4, WKT6 WMBO, WME2, WME4, WMT
					1	-	-	-	-----	-----	QS2, VES, VHA7, VPM5
					1	-	-	-	8382121	-----	HXE2
					-	1	-	-	8367037	-----	R1, W1
					-	-	-	1	2000272	-----	SXP1

NOTE A:PART NO. CHANGE D:NEWLY PROVIDED E:PART NO.DELETION K:REQUIRED NO. CORRECTION L:APPLICATION SERIAL NO. CORRECTION
T:APPLICATION CORRECTION Z:REMARKS CHANGE



PARTS CATALOGUE NEWS

Honda Motor Co., Ltd. Service Division

PARTS CATALOGUE - CORRECTED

Printed in Japan

CODE NO.	BOOKLET TYPE	13ZH81E0
	MICRO- FICHE	13ZH80EJ/FJ
PARTS CATALOGUE TITLE	GX160K1 GX160K1[PROPANE ENGINE]	
NEWS NO.	004	

Block No.	Ref. No.	Note	Part No.	Description	Reqd. QTY				Serial No.	Parts catalogue code	
					(1)	(2)	(3)	(4)			
E-12	7	L	19611-ZH8-810	PLATE COMP., SIDE (OIL ALERT)	1	(1)	-	-	5372719	-----	HG12, HX, HX2, HX26, HX4, LJC7, LX, LX2, LX26, LX4, L1, PX PX2, QBT2, QBT6, QGR2, QMC8, QMH, QMX2, QNT, QNT4, QWM2 QWX2, QX, QXB1, QXC, QXC6, QXC9, QXF2, QXM1, QXQ, QX2, QX26 QX4, Q1, RX, RX4, SG24, SJC1, SJC5, SMC7, SMJ, SMJ1, SMW2 SNX, SSX2, SX, SXB, SX4, S1, TX, TXC9, TX2, TX26, TX4, UX, VA2 VEBM, VED1, VED2, VED3, VED5, VED7, VGE4, VG24, VHH4, VMB3 VMS4, VPM4, VPR4, VSB1, VSD, VSD1, VSX, VSX1, VS3, VS4, VTD VTD1, VTX, VTX1, VWA2, VW12, VX, VXG, VXM, VXU, VXW2, VX2 VX26, VX4, WKT2, WME2, WMT, W1
					1	-	1	-	-----	-----	HXU, LXU, PXU, QCL, Q12, QS2, QWA4, QWX3, QXU, QX22, QX7, RXU SMX4, SM12, SM14, SWX2, SWX4, SXS4, SXU, SX7, TGS2, TXU, UXU VED6, VEN2, VHA7, VIH1, VMS7, VMT, VPM5, VPM7, VPR7, VSD7 VSG, VSX3, VS17, VTU1, VXU1, WKD6, WKT4, WKT6
					-	-	-	1	5066323	-----	VSDP, VXP
		T	19612-ZH8-812	PLATE, SIDE (OIL ALERT)	1	(1)	-	-	5066323	5372718	HG12, HX, HX2, HX26, HX4, LJC7, LX, LX2, LX26, LX4, L1, PX PX2, QBT2, QBT6, QGR2, QMC8, QMH, QMX2, QNT, QNT4, QWM2 QWX2, QX, QXB1, QXC, QXC6, QXC9, QXF2, QXQ, QX2, QX26, QX4 Q1, RX, RX4, SG24, SJC1, SJC5, SMC7, SMJ, SMJ1, SMW2, SNX SSX2, SX, SXB, SX4, S1, TX, TXC9, TX2, TX26, TX4, UX, VA2 VEBM, VED1, VED2, VED3, VED5, VED7, VGE4, VG24, VHH4, VMB3 VMS4, VPM4, VPR4, VSB1, VSD, VSD1, VSX, VSX1, VS3, VS4, VWA2 VW12, VX, VXG, VXM, VXU, VXW2, VX2, VX26, VX4, WKT2, WME2 WMT, W1

NOTE A:PART NO. CHANGE D:NEWLY PROVIDED E:PART NO.DELETION K:REQUIRED NO. CORRECTION L:APPLICATION SERIAL NO. CORRECTION
T:APPLICATION CORRECTION Z:REMARKS CHANGE

PARTS CATALOGUE NEWS

BOOKNo. : 13ZH81E0

Block No.	Ref. No.	Note	Part No.	Description	Reqd. QTY				Serial No.	Parts catalogue code
					(1)	GX160K1 (2)	(3)	(4)		
					1	-	-	-	----- 5372718	QXM1, VTD, VTD1, VTX, VTX1

NOTE A:PART NO. CHANGE D:NEWLY PROVIDED E:PART NO.DELETION K:REQUIRED NO. CORRECTION L:APPLICATION SERIAL NO. CORRECTION
T:APPLICATION CORRECTION Z:REMARKS CHANGE

January 23, 2005



PARTS CATALOGUE NEWS

Honda Motor Co., Ltd. Service Division

PARTS CATALOGUE - CORRECTED

Printed in Japan

CODE NO.	BOOKLET TYPE	13ZH81E0
	MICRO- FICHE	13ZH80EJ/FJ
PARTS CATALOGUE TITLE	GX160K1 GX160K1[PROPANE ENGINE]	
NEWS NO.	005	

Block No.	Ref. No.	Note	Part No.	Description	Reqd. QTY				Serial No.	Parts catalogue code
					(1)	(2)	(3)	(4)		
E-3	23	E	34150-ZH7-003	*PARTS NO. DELETION						
	24	E	95701-06008-00	*PARTS NO. DELETION						

NOTE A:PART NO. CHANGE D:NEWLY PROVIDED E:PART NO. DELETION K:REQUIRED NO. CORRECTION L:APPLICATION SERIAL NO. CORRECTION
T:APPLICATION CORRECTION Z:REMARKS CHANGE

PARTS CATALOGUE NEWS

BOOKNo. : 13ZH81E0

Block No.	Ref. No.	Note	Part No.	Description	Reqd. QTY				Serial No.	Parts catalogue code
					(1)	GX160K1 (2)	(3)	(4)		

E-12 FAN COVER

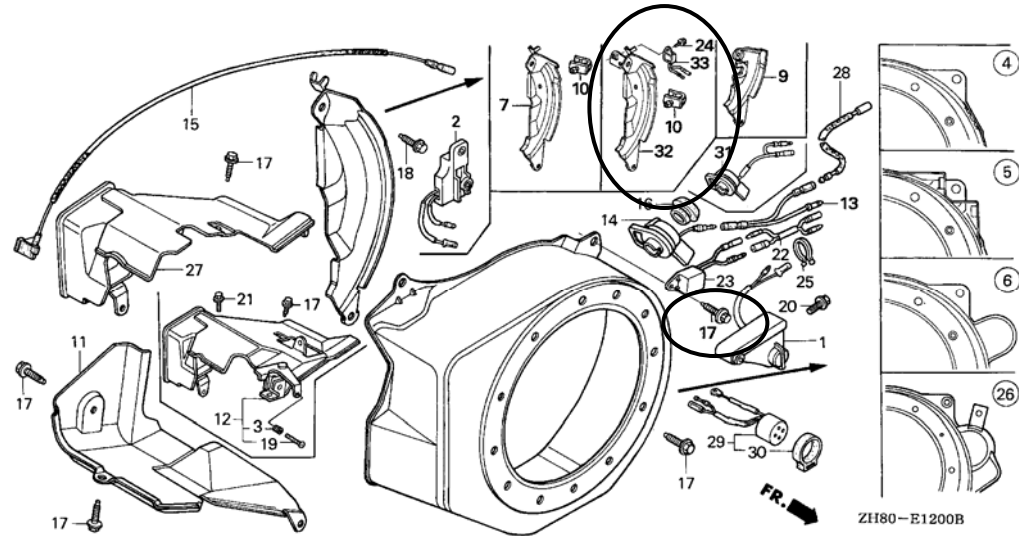

E-12	7	E	19611-ZH8-810	*PARTS NO. DELETION						
		E	19611-ZH8-820	*PARTS NO. DELETION						
		L	19612-ZH8-811	PLATE, SIDE (OIL ALERT)	1	(1)	-	-	4795906	----- ETX, HG1, HXQ, QBU2, QNT2, QXB, QXF, R1, SAD2, SWX, T1, VA VEB2, VWA, VXW, VXW1, V1
					1	(1)	-	-	4795906 5066322	HG12, HX, HX2, HX26, HX4, LJC7, LX, LX2, LX26, LX4, L1, PX PX2, QBT2, QBT6, QGR2, QMC8, QMH, QMX2, QNT, QWM2, QWX2, QX QXB1, QXC, QXC6, QXC9, QXF2, QXQ, QX2, QX26, QX4, Q1, RX, RX4 SG24, SJC1, SJC5, SMC7, SMJ, SMJ1, SMW2, SNX, SSS2, SX, SXB SX4, S1, TX, TXC9, TX2, TX26, TX4, UX, VA2, VEBM, VED1, VED2 VED3, VED5, VGE4, VG24, VHH4, VMB3, VMS4, VSD, VSD1, VSX VSX1, VS3, VS4, VWA2, VW12, VX, VXG, VXM, VXU, VXW2, VX2 VX26, VX4, WKT2, WME2, WMT, W1
					1	-	-	-	----- 5066322	QNT4, VED7, VPM4, VPR4, VSB1
					-	-	-	1	2000029 2000068	VSDP, VXP
	23	T	34150-ZH7-003	ALERT UNIT, OIL	1	-	-	-	-----	STM
					1	-	-	-	5372719	----- SKM, SNX1, SWG4, VSW

NOTE A:PART NO. CHANGE D:NEWLY PROVIDED E:PART NO.DELETION K:REQUIRED NO. CORRECTION L:APPLICATION SERIAL NO. CORRECTION
T:APPLICATION CORRECTION Z:REMARKS CHANGE

PARTS CATALOGUE NEWS

BOOKNo. : 13ZH81E0

Block No.	Ref. No.	Note	Part No.	Description	Reqd. QTY				Serial No.	Parts catalogue code
					(1)	GX160K1 (2)	(3)	(4)		
	24	T	95701-06008-00	BOLT, FLANGE, 6X8	1	(1)	-	-	5372719 -----	EMA, EMA2, HG12, HX, HX2, HX26, HX4, LJC7, LX, LX2, LX26, LX4, L1, PX, PX2, QAX2, QBT2, QBT6, QGR2, QMC8, QMD6, QMH, QMX2, QNT, QNT4, QWM2, QWX2, QX, QXB1, QXC, QXC6, QXC9, QXF2, QXQ, QXS2, QX2, QX26, QX4, Q1, RX, RX4, SG24, SJC1, SJC5, SMC7, SMC9, SMJ, SMJ1, SMW2, SNX, SSSX2, SX, SXB, SX4, S1, TX, TXC9, TX2, TX4, UX, VA2, VEBM, VED1, VED2, VED3, VED5, VED7, VGE4, VG24, VHH4, VMB3, VMS4, VPM4, VPR4, VSB1, VSD, VSD1, VSX, VSX1, VS3, VS4, VTD, VTD1, VTX, VTX1, VWA2, VW12, VX, VXD, VXD1, VXG, VXM, VXU, VXW2, VX2, VX26, VX4, WKT2, WME2, WMT, W1
					1	-	1	1	-----	HXU, LXU, PXU, QCL, QGR9, Q12, QSC9, QS2, QWA4, QWX3, QXU, QX22, QX7, RXU, SMX4, SM12, SM14, SWX2, SWX4, SXP1, SXS4, SXU, SX7, TCS2, TXU, UXU, VED6, VEN2, VES, VHA7, VIH1, VMS7, VMT, VPM5, VPM7, VPR7, VSD7, VSG, VSX3, VS17, VTU1, VXU1, WKD6, WKT4, WKT6
					-	-	-	1	2000069 -----	VSDP, VXP
	32	D	19611-ZH8-810	PLATE COMP. , SIDE (OIL ALERT)	1	(1)	-	-	5372719 -----	HG12, HX, HX2, HX26, HX4, LJC7, LX, LX2, LX26, LX4, L1, PX, PX2, QBT2, QBT6, QGR2, QMC8, QMH, QMX2, QNT, QNT4, QWM2, QWX2, QX, QXB1, QXC, QXC6, QXC9, QXF2, QXM1, QXQ, QX2, QX26, QX4, Q1, RX, RX4, SG24, SJC1, SJC5, SMC7, SMJ, SMJ1, SMW2, SNX, SSSX2, SX, SXB, SX4, S1, TX, TXC9, TX2, TX26, TX4, UX, VA2, VEBM, VED1, VED2, VED3, VED5, VED7, VGE4, VG24, VHH4, VMB3, VMS4, VPM4, VPR4, VSB1, VSD, VSD1, VSX, VSX1, VS3, VS4, VTD, VTD1, VTX, VTX1, VWA2, VW12, VX, VXG, VXM, VXU, VXW2, VX2, VX26, VX4, WKT2, WME2, WMT, W1
					1	-	1	-	-----	HXU, LXU, PXU, QCL, Q12, QS2, QWA4, QWX3, QXU, QX22, QX7, RXU, SMX4, SM12, SM14, SWX2, SWX4, SXS4, SXU, SX7, TCS2, TXU, UXU, VED6, VEN2, VHA7, VIH1, VMS7, VMT, VPM5, VPM7, VPR7, VSD7, VSG, VSX3, VS17, VTU1, VXU1, WKD6, WKT4, WKT6
					-	-	-	1	2000069 -----	VSDP, VXP
		D	19611-ZH8-820	PLATE COMP. , SIDE (ALERT & LAMP)	1	(1)	-	-	5372719 -----	EMA, EMA2, QAX2, QMD6, QXS2, Q1, SMC9, S1, VXD, VXD1
					1	-	-	1	-----	QGR9, QSC9, SXP1, VES

NOTE A:PART NO. CHANGE D:NEWLY PROVIDED E:PART NO.DELETION K:REQUIRED NO. CORRECTION L:APPLICATION SERIAL NO. CORRECTION
T:APPLICATION CORRECTION Z:REMARKS CHANGE

PARTS CATALOGUE NEWS

BOOKNo. : 13ZH81E0

Block No.	Ref. No.	Note	Part No.	Description	Reqd. QTY				Serial No.	Parts catalogue code
					(1)	GX160K1 (2)	(3)	(4)		
	33	D	34150-ZH7-003	ALERT UNIT, OIL	1	(1)	-	-	5372719 -----	EMA, EMA2, HG12, HX, HX2, HX26, HX4, LJC7, LX, LX2, LX26, LX4, L1, PX, PX2, QAX2, QBT2, QBT6, QGR2, QMC8, QMD6, QMH, QMX2, QNT, QNT4, QWM2, QWX2, QX, QXB1, QXC, QXC6, QXC9, QXF2, QXM1, QXQ, QXS2, QX2, QX26, QX4, Q1, RX, RX4, SG24, SJC1, SJC5, SMC7, SMC9, SMJ, SMJ1, SMW2, SNX, SSX2, SX, SXB, SX4, S1, TX, TXC9, TX2, TX26, TX4, UX, VA2, VEBM, VED1, VED2, VED3, VED5, VED7, VGE4, VG24, VHH4, VMB3, VMS4, VPM4, VPR4, VSB1, VSD, VSD1, VSX, VSX1, VS3, VS4, VTD, VTD1, VTX, VTX1, VWA2, VW12, VX, VXD, VXD1, VXG, VXM, VXU, VXW2, VX2, VX26, VX4, WKT2, WME2, WMT, W1
					1	-	1	1	-----	HXU, LXU, PXU, QCL, QGR9, Q12, QSC9, QS2, QWA4, QWX3, QXU, QX22, QX7, RXU, SMX4, SM12, SM14, SWX2, SWX4, SXP1, SXS4, SXU, SX7, TCS2, TXU, UXU, VED6, VEN2, VES, VHA7, VIH1, VMS7, VMT, VPM5, VPM7, VPR7, VSD7, VSG, VSX3, VS17, VTU1, VXU1, WKD6, WKT4, WKT6
					-	-	-	1	2000069 -----	VSDP, VXP

NOTE A:PART NO. CHANGE D:NEWLY PROVIDED E:PART NO.DELETION K:REQUIRED NO. CORRECTION L:APPLICATION SERIAL NO. CORRECTION
T:APPLICATION CORRECTION Z:REMARKS CHANGE



PARTS CATALOGUE NEWS

Honda Motor Co., Ltd. Service Division

PARTS CATALOGUE - CORRECTED

Printed in Japan

CODE NO.	BOOKLET TYPE	13ZH81E0
	MICRO-FICHE	13ZH80EJ/FJ
PARTS CATALOGUE TITLE	GX160K1 GX160K1[PROPANE ENGINE]	
NEWS NO.	006	

Block No.	Ref. No.	Note	Part No.	Description	Reqd. QTY				Serial No.	Parts catalogue code
					(1)	GX160K1 (2)	(3)	(4)		
E-11	1		28400-ZH8-822ZA	STARTER ASSY., RECOIL (LONG ROPE) *R8*..... BRIGHT RED	1	-	-	-	----- 8366916	QSC9
					-	(1)	-	-	2438253	
			28400-ZH8-R10ZA	STARTER ASSY., RECOIL (TURFCO) *R8*..... BRIGHT RED	1	-	-	-	----- 8364201	HG12, SNX, SNX1
					1	-	-	-	2828661 -----	HG1
	A		28400-ZH8-822ZD	STARTER ASSY., RECOIL (LONG ROPE) *R280*..... POWER RED	1	-	-	-	8366917 -----	QSC9
	A		28400-ZH8-R10ZD	STARTER ASSY., RECOIL (TURFCO) *R280*..... POWER RED	1	-	-	-	8364202 -----	HG12, SNX, SNX1

NOTE A:PART NO. CHANGE D:NEWLY PROVIDED E:PART NO. DELETION K:REQUIRED NO. CORRECTION L:APPLICATION SERIAL NO. CORRECTION
T:APPLICATION CORRECTION Z:REMARKS CHANGE

PARTS CATALOGUE NEWS

BOOKNo. : 13ZH81E0

Block No.	Ref. No.	Note	Part No.	Description	Reqd. QTY				Serial No.	Parts catalogue code	
					(1)	(2)	(3)	(4)			
	2	L	28410-ZH8-003ZA	CASE COMP., RECOIL STARTER *R8*..... BRIGHT RED	1	(1)	-	1	-----	-----	DS, DSP, EN, ET, ETX, HG1, HXE, HXQ, H1, KR, LAX, LAX2, LDB1, LDB3, LDM, LD4, LHW, LJD, LSJ, LSS, LSS1, LSS4, LTA, LTK, NW, PH, PHU, PM, PM2, PX2, QA, QAB1, QAX, QBU2, QM, QNT2, QXB, QXB1, QXF, QXQ, QXS, QXW2, QZ, Q1, RAC, REX4, RFR, RFR2, RHA, RNG, R1, SAC, SAD2, SDB1, SDB3, SDN, SDS2, SDS3, SEE, SHR4, SJC, SMB4, STA, STP, SWX, SW2, SXB, S1, TH, THU, T1, UH, UX, U1, VA, VEB2, VED5, VH, VHQ4, VMB3, VS, VSDP, VS1, VTD, VTE2, VWA, VXE, VXE6, VXG, VXP, VXW, VX26, V1, W1
					1	(1)	-	-	-----	8367072	HH26, HXE2, HXE8, HXU, HX26, LXU, LX26, L1, PXU, QA26, QBC2, QBT6, QH26, QWA4, QXC6, QXE4, QXE6, QXE8, QXM1, QXU, QX26, QX7, RH26, RXE4, RXU, SD16, SXU, SX7, TXU, TX26, UXU, VMS7, VPM7, VPR7, VSD7, VS17, VXE4, VXE7, VXU1, WKT6
					1	-	-	-	-----	5551817	SWG4
					1	-	-	-	-----	5641954	STM
					1	-	-	-	-----	6219318	QT
					1	-	-	-	-----	8364201	HG12, SNX, SNX1
					1	-	-	-	-----	8366916	AR, ARC6, BL, HH, HHQ4, HX, HX2, HX4, KTA, LD, LH, LHB3, LHQ4, LJ, LJC7, LJG, LSJ4, LW2, LX, LX2, LX4, NJ, NJG, NSJ, PHM, PX, QAB3, QAX2, QA2, QCB2, QCL, QD, QE, QFE4, QGR2, QGR9, QH, QHE, QHP1, QHQ4, Q12, QKA4, QMC6, QMC8, QMD6, QME4, QMH, QMX2, QMZ2, QNT, QNT4, QNZ, QP, QPU, QSC2, QSC9, QX, QXC, QXC9, QXE, QXE2, QXF2, QXS2, QXW, QX2, QX22, QX4, RD, RD4, RH, RHA2, RHQ4, RH2, RMB4, RMD, RMG2, RSK, RSS1, RTB2, RX, RXE, RXE2, RX4, SCJ, SD, SDS, SD4, SE, SG24, SH, SHM, SHQ4, SHRY, SJ, SJC1, SJC5, SJG, SMC7, SMC9, SMJ, SMJ1, SMW2, SMX4, SM11, SM12, SM14, ST, STQ, SX, SXE, SXE4, SXS4, SX4, S1CY, TCS2, TX, TXC9, TX2, TX4, VA2, VEBM, VED, VED1, VED2, VED3, VGE4, VG24, VHH4, VMS4, VMT, VPM4, VPR4, VSD, VSD1, VSX, VSX1, VSX3, VTU1, VX, VXM, VXU, VXW2, VX2, VX4, WDA6, WJP, WKD6, WKT2, WKT4, WMBO, WME2, WME4, WMT
					-	-	1	-			
					-	-	-	1	-----	2000271	SXP1
		T	28410-ZH8-003YA	*R280*..... POWER RED	1	(1)	-	-	8367073	-----	HH26, HXE2, HXE8, HXU, HX26, LXU, LX26, L1, PXU, QA26, QBC2, QBT6, QH26, QWA4, QXC6, QXE4, QXE6, QXE8, QXM1, QXU, QX26, QX7, RH26, RXE4, RXU, SD16, SXU, SX7, TXU, TX26, UXU, VMS7, VPM7, VPR7, VSD7, VS17, VXE4, VXE7, VXU1, WKT6
					1	-	-	-	-----	-----	QS2, VES, VHA7, VPM5

NOTE A:PART NO. CHANGE D:NEWLY PROVIDED E:PART NO. DELETION K:REQUIRED NO. CORRECTION L:APPLICATION SERIAL NO. CORRECTION
T:APPLICATION CORRECTION Z:REMARKS CHANGE

PARTS CATALOGUE NEWS

BOOKNo. : 13ZH81E0

Block No.	Ref. No.	Note	Part No.	Description	Reqd. QTY				Serial No.	Parts catalogue code	
					(1)	GX160K1 (2)	(3)	(4)			
					1	-	-	-	8364202	-----	HG12, SNX, SNX1
					1	-	-	-	8366917	-----	AR, ARC6, BL, HH, HHQ4, HX, HX2, HX4, KTA, LD, LH, LHB3, LHQ4 LJ, LJC7, LJG, LSJ4, LW2, LX, LX2, LX4, NJ, NJG, NSJ, PHM, PX QAB3, QAX2, QA2, QCB2, QCL, QD, QE, QFE4, QGR2, QGR9, QH, QHE QHP1, QHQ4, QI2, QKA4, QMC6, QMC8, QMD6, QME4, QMH, QMX2 QMZ2, QNT, QNT4, QNZ, QP, QPU, QSC2, QSC9, QX, QXC, QXC9, QXE QXE2, QXF2, QXS2, QXW, QX2, QX22, QX4, RD, RD4, RH, RHA2 RHQ4, RH2, RMB4, RMD, RMG2, RSK, RSS1, RTB2, RX, RXE, RXE2 RX4, SCJ, SD, SDS, SD4, SE, SG24, SH, SHM, SHQ4, SHRY, SJ SJC1, SJC5, SJG, SMC7, SMC9, SMJ, SMJ1, SMW2, SMX4, SM11 SM12, SM14, ST, STQ, SX, SXE, SXE4, SXS4, SX4, S1CY, TCS2, TX TXC9, TX2, TX4, VA2, VEBM, VED, VED1, VED2, VED3, VGE4, VG24 VHH4, VMS4, VMT, VPM4, VPR4, VSD, VSD1, VSX, VSX1, VSX3 VTU1, VX, VXM, VXU, VXW2, VX2, VX4, WDA6, WJP, WKD6, WKT2 WKT4, WMBO, WME2, WME4, WMT
					-	-	-	1	2000272	-----	SXP1
	14		28414-ZH8-841ZB	CASE B, STARTER *R8*..... BRIGHT RED	1	-	-	-	5641955	8364201	STM
		A	28414-ZH8-841ZC	*R280*..... POWER RED	1	-	-	-	8364202	-----	STM
E-11-1	1		28400-ZB2-000ZB	STARTER ASSY., RECOIL *R8*..... BRIGHT RED	1	-	-	-	-----	-----	VSW, VS4
					1	-	-	-	-----	8364201	VSB1, VSG, VS3
			28400-ZE1-003ZA	*R8*..... BRIGHT RED	1	-	-	-	-----	8364201	LVL, QVL
					1	-	-	-	6219319	8364201	QT
		A	28400-ZB2-000ZH	*R280*..... POWER RED	1	-	-	-	8364202	-----	VSB1, VSG, VS3
		A	28400-ZE1-003ZF	*R280*..... POWER RED	1	-	-	-	8364202	-----	LVL, QT, QVL
	2		28410-ZB2-000ZB	CASE COMP., RECOIL STARTER *R8*..... BRIGHT RED	1	-	-	-	-----	-----	VSW, VS4
					1	-	-	-	-----	8364201	VSB1, VSG, VS3
			28410-ZE1-003ZA	*R8*..... BRIGHT RED	1	-	-	-	-----	8364201	LVL, QVL
					1	-	-	-	6219319	8364201	QT
		A	28410-ZB2-000ZJ	*R280*..... POWER RED	1	-	-	-	8364202	-----	VSB1, VSG, VS3

NOTE A:PART NO. CHANGE D:NEWLY PROVIDED E:PART NO. DELETION K:REQUIRED NO. CORRECTION L:APPLICATION SERIAL NO. CORRECTION
T:APPLICATION CORRECTION Z:REMARKS CHANGE

PARTS CATALOGUE NEWS

BOOKNo. : 13ZH81E0

Block No.	Ref. No.	Note	Part No.	Description	Reqd. QTY				Serial No.	Parts catalogue code
					(1)	(2)	(3)	(4)		
		A	28410-ZE1-003ZF	*R280*.....POWER RED	1	-	-	-	8364202 -----	LVL, QT, QVL
E-12	4	L	19610-ZE1-000ZA	COVER COMP. , FAN *R8*..... BRIGHT RED	1	(1)	-	1	-----	DS, DSP, EN, ET, ETX, HXQ, H1, LAX, LAX2, LDB1, LDB3, LDM, LD4 LHW, LJD, LMT, LSS, LTA, LTK, NW, PH, PM, PM2, PX2, QA, QAB1 QAX, QBU2, QM, QNT2, QXB, QXB1, QXQ, QZ, Q1, RAC, RFR, RFR2 RHA, RNG, R1, SAC, SAD2, SDB1, SDB3, SDN, SDS2, SDS3, SHR4 SJC, SMB4, STA, STM, STP, SXB, S1, TH, T1, UH, U1, VEB2, VED5 VH, VHQ4, VMB3, VS, VSDP, VS1, VS4, VTD, VTE2, VWA, VXG, VXP VX26, V1, W1
					1	(1)	-	-	----- 8364201	BL, HG12, HHQ4, HH26, HXU, HX26, HX4, LHB3, LHQ4, LJC7, LVL LXU, LX26, LX4, L1, NSJ, PHM, PXU, QAB3, QAX2, QA26, QBC2 QBT6, QCB2, QE, QFE4, QGR9, QHP1, QHQ4, QH26, QMC6, QMC8 QMD6, QME4, QMH, QMX2, QMZ2, QNT4, QP, QPU, QSC9, QVL, QWA4 QXC6, QXC9, QXM1, QXU, QX26, QX4, QX7, RD4, RHA2, RHQ4, RH26 RMB4, RMG2, RSS1, RTB2, RXU, RX4, SD16, SD4, SE, SHM, SHQ4 SMC7, SMC9, SMW2, SM11, SM12, SM14, SNX, SXS4, SXU, SX4, SX7 S1CY, TGS2, TXC9, TXU, TX26, TX4, UXU, VA2, VGE4, VHH4, VMS4 VMS7, VMT, VPM4, VPM7, VPR4, VPR7, VSB1, VSD7, VSG, VSX3 VTU1, VXM, VXU1, VXW2, VX4, WJP, WKT2, WKT4, WKT6, WMBO WME2, WME4, WMT
					1	-	-	-	----- 6481740	SHRY
					1	-	-	-	----- 8369925	HH, HX2, KTA, LD, LH, LJ, LJG, LJS, LX2, NJ, NJG, QA2, QCL, QD QGR2, QH, Q12, QT, QXF2, QXS2, QX2, QX22, RD, RH, RH2, RMD RSK, SCJ, SD, SH, SJ, SJG, SMX4, STQ, TX2, VED, VED2, VED3 VSX1, VS3, VXU, VX2, WDA6, WKD6
					1	-	-	-	2468253 -----	HG1, QXF, QXS, SWX, UX, VA, VXW
					1	-	-	-	2468253 2744590	VSD1
					1	-	-	-	2468253 8364201	QXC
					1	-	-	-	2468253 8369925	HX, LX, PX, QNT, QX, RX, SMJ, SMJ1, SX, TX, VEBM, VED1, VSD VSX, VX
					-	-	1	-		
					-	-	-	1	----- 8366916	SXP1
			19610-ZK8-V00ZA	*R8*..... BRIGHT RED	1	-	-	-	----- 8366916	AR, ARC6, KR

NOTE A:PART NO. CHANGE D:NEWLY PROVIDED E:PART NO.DELETION K:REQUIRED NO. CORRECTION L:APPLICATION SERIAL NO. CORRECTION
T:APPLICATION CORRECTION Z:REMARKS CHANGE

PARTS CATALOGUE NEWS

BOOKNo. : 13ZH81E0

Block No.	Ref. No.	Note	Part No.	Description	Reqd. QTY				Serial No.	Parts catalogue code	
					(1)	GX160K1 (2)	(3)	(4)			
		T	19610-ZE1-000ZP	*R280*.....POWER RED	1	1	-	-	8364202	-----	BL, HG12, HHQ4, HH26, HXU, HX26, HX4, LHB3, LHQ4, LJC7, LVL LW2, LXU, LX26, LX4, L1, NSJ, PHM, PXU, QAB3, QAX2, QA26 QBC2, QBT6, QCB2, QE, QFE4, QGR9, QHP1, QHQ4, QH26, QMC6 QMC8, QMD6, QME4, QMH, QMX2, QMZ2, QNT4, QP, QPU, QSC9, QVL QWA4, QXC, QXC6, QXC9, QXM1, QXU, QX26, QX4, QX7, RD4, RHA2 RHQ4, RH26, RMB4, RMG2, RSS1, RTB2, RXU, RX4, SD16, SD4, SE SG24, SHM, SHQ4, SMC7, SMC9, SMW2, SM11, SM12, SM14, SNX SXS4, SXU, SX4, SX7, S1CY, TCS2, TXC9, TXU, TX26, TX4, UXU VA2, VGE4, VG24, VHH4, VMS4, VMS7, VMT, VPM4, VPM7, VPR4 VPR7, VSB1, VSD7, VSG, VSX3, VTU1, VXM, VXU1, VXW2, VX4, WJP WKT2, WKT4, WKT6, WMBO, WME2, WME4, WMT
					1	-	-	-	-----	-----	QS2, SDS, VES, VHA7, VPM5
					1	-	-	-	8369926	-----	HH, HX, HX2, KTA, LD, LH, LJ, LJG, LJS, LX, LX2, NJ, NJG, PX QA2, QCL, QD, QGR2, QH, Q12, QNT, QT, QX, QXF2, QXS2, QX2 QX22, RD, RH, RH2, RMD, RSK, RX, SCJ, SD, SH, SJ, SJG, SMJ SMJ1, SMX4, STQ, SX, TX, TX2, VEBM, VED, VED1, VED2, VED3 VSD, VSX, VSX1, VS3, VX, VXU, VX2, WDA6, WKD6
					-	-	-	1	8366917	-----	SXP1
		A	19610-ZK8-V00ZD	*R280*.....POWER RED	1	-	-	-	8366917	-----	AR, ARC6, KR
	5		19610-ZE1-810ZA	COVER COMP., FAN (OIL ALERT) *R8*.....BRIGHT RED	1	-	-	-	-----	2468252	HG1, HX, LX, PX, QNT, QX, QVC, QXF, QXS, RX, SMJ, SMJ1, SWX SX, TX, UX, VA, VEBM, VED1, VSD, VSD1, VSX, VX, VXW
					-	(1)	-	-	-----	2468252	
					1	-	-	-	-----	8364201	VS17
					1	-	-	-	2744591	8364201	VSD1
		A	19610-ZE1-810ZG	*R280*.....POWER RED	1	-	-	-	8364202	-----	VSD1, VS17
E-23	3		31610-ZE1-812ZB	BOX ASSY., CONTROL (EXTERNAL) *R8*.....BRIGHT RED	1	-	-	-	-----	-----	SEE
					1	-	-	-	-----	8364201	QHE
					-	(1)	-	-			
		A	31610-ZE1-812ZD	*R280*.....POWER RED	1	-	-	-	8364202	-----	QHE
			31610-ZH8-R93ZA	BOX ASSY., CONTROL (EXP, 10A) *R8*.....BRIGHT RED	1	-	-	-	5372719	-----	REX4

NOTE A:PART NO. CHANGE D:NEWLY PROVIDED E:PART NO. DELETION K:REQUIRED NO. CORRECTION L:APPLICATION SERIAL NO. CORRECTION
T:APPLICATION CORRECTION Z:REMARKS CHANGE

PARTS CATALOGUE NEWS

BOOKNo. : 13ZH81E0

Block No.	Ref. No.	Note	Part No.	Description	Reqd. QTY				Serial No.		Parts catalogue code
					(1)	GX160K1 (2)	(3)	(4)			
					1	-	-	-	5372719	8364201	QXW
					1	-	-	-	5380586	8364201	QSC2
		A	31610-ZH8-R93ZD	*R280* POWER RED	1	-	-	-	8364202	-----	QSC2, QXW
			31610-ZE1-013ZB	BOX ASSY., CONTROL (INTERNAL) *R8* BRIGHT RED	-	(1)	-	-	-----	-----	H1, Q1, R1, S1, T1, U1, V1, W1
					-	(1)	-	-	-----	8364201	L1
		A	31610-ZE1-013ZD	*R280* POWER RED	-	(1)	-	-	8364202	-----	L1
E-23-1		4	31610-ZK8-W42ZA	BOX ASSY., CONTROL (EXTERNAL-ALERT) *R8* BRIGHT RED	1	-	-	-	-----	8366916	VXE7
					1	-	-	-	5372719	8366916	QKA4, QXE4, RXE4, SXE4, VXE4
		A	31610-ZK8-W42ZF	BOX ASSY., CONTROL (EXP-ALERT) *R280* POWER RED	1	-	-	-	8366917	-----	QKA4, QXE4, RXE4, SXE4, VXE4, VXE7
		7	L	31615-ZE1-003ZB	PANEL COMP., CONTROL *R8* BRIGHT RED	1	(1)	-	-----	-----	HXE, H1, Q1, R1, S1, T1, U1, VXE, VXE6, V1, W1
					1	(1)	-	-	-----	8394660	HXE2, L1, QKA4, QXE, QXE2, QXE4, QXE6, QXE8, RXE, RXE2, RXE4, SXE, SXE4, VXE4, VXE7
					1	-	-	-	-----	8366916	HXE8
		T	31615-ZE1-003ZG	*R280* POWER RED	1	(1)	-	-	8394661	-----	HXE2, L1, QKA4, QXE, QXE2, QXE4, QXE6, QXE8, RXE, RXE2, RXE4, SXE, SXE4, VXE4, VXE7
					1	-	-	-	8366917	-----	HXE8

NOTE A:PART NO. CHANGE D:NEWLY PROVIDED E:PART NO. DELETION K:REQUIRED NO. CORRECTION L:APPLICATION SERIAL NO. CORRECTION
T:APPLICATION CORRECTION Z:REMARKS CHANGE



PARTS CATALOGUE NEWS

Honda Motor Co., Ltd. Service Division

PARTS CATALOGUE - CORRECTED

Printed in Japan

CODE NO.	BOOKLET TYPE	13ZH81E0
	MICRO- FICHE	13ZH80EJ/FJ
PARTS CATALOGUE TITLE	GX160K1 GX160K1[PROPANE ENGINE]	
NEWS NO.	007	

Block No.	Ref. No.	Note	Part No.	Description	Reqd. QTY				Serial No.	Parts catalogue code
					(1)	(2)	(3)	(4)		
E-23-1	16		87529-ZH9-W40	MARK, CONTROL BOX (ENGLISH) ...	1	-	-	-	8897212	QKA4, QXE4, RXE4, SXE4, VXE4, VXE7
		A	87529-ZH9-W41	1	-	-	-	8897213	QKA4, QXE4, RXE4, SXE4, VXE4, VXE7
E-28	3		87522-ZH8-W40	MARK, CAUTION (PICTOGRAPH) ...	1	-	-	-	8953905	QX7, SG24, SX7, VG24, VHA7, VMS7, VSD7, VXE7
		A	87522-ZH8-W41	1	-	-	-	8953906	QX7, SG24, SX7, VG24, VHA7, VMS7, VSD7, VXE7
	8		87522-ZH8-W40	MARK, CAUTION (PICTOGRAPH) ...	1	-	-	1	-----	LD4, LSS4, REX4, SHR4, SMB4, VHQ4, VSDP, VSW
					1	-	-	-	8953905	HHQ4, HX4, LHQ4, LSJ4, LX4, QBC2, QFE4, QHQ4, QKA4, QMC6, QMC8, QMD6, QME4, QNT4, QPU, QWA4, QXE4, QX4, RD4, RHQ4, RMB4, RXE4, RX4, SD4, SHQ4, SHRY, SMC7, SMC9, SMX4, SM14, SWG4, SWX4, SXE4, SXS4, SX4, S1CY, TX4, VMS4, VXE4, VX4, WKT4, WMBO, WME4
					1	-	-	-	3343604	VXG
				1	-	-	-	3343604	8953905	QE, QNT, QXW, RSK, SDS, SE, VSD
	A		87522-ZH8-W41	1	-	-	-	8953906	HHQ4, HX4, LHQ4, LSJ4, LX4, QBC2, QE, QFE4, QHQ4, QKA4, QMC6, QMC8, QMD6, QME4, QNT, QNT4, QPU, QWA4, QXE4, QXW, QX4, RD4, RHQ4, RMB4, RSK, RXE4, RX4, SDS, SD4, SE, SHQ4, SHRY, SMC7, SMC9, SMX4, SM14, SWG4, SWX4, SXE4, SXS4, SX4, S1CY, TX4, VMS4, VSD, VXE4, VX4, WKT4, WMBO, WME4

NOTE A:PART NO. CHANGE D:NEWLY PROVIDED E:PART NO.DELETION K:REQUIRED NO. CORRECTION L:APPLICATION SERIAL NO. CORRECTION
T:APPLICATION CORRECTION Z:REMARKS CHANGE



PARTS CATALOGUE NEWS

Honda Motor Co., Ltd. Service Division

PARTS CATALOGUE - CORRECTED

Printed in Japan

CODE NO.	BOOKLET TYPE	13ZH81E0
	MICRO-FICHE	13ZH80EJ/FJ
PARTS CATALOGUE NEWS	GX160K1 GX160K1[PROPANE ENGINE]	
NEWS NO.	008	

Block No.	Ref. No.	Note	Part No.	Description	Reqd. QTY	Serial No.	Parts catalogue code
					(1) (2) (3) (4)		

E-21 STARTER MOTOR

ILLUSTRATION CORRECTED

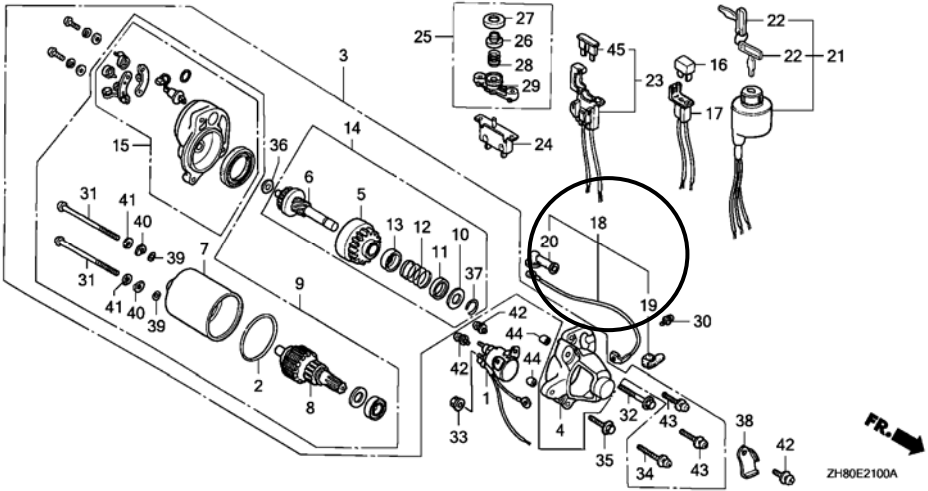

NOTE A:PART NO. CHANGE D:NEWLY PROVIDED E:PART NO. DELETION K:REQUIRED NO. CORRECTION L:APPLICATION SERIAL NO. CORRECTION
T:APPLICATION CORRECTION Z:REMARKS CHANGE



PARTS CATALOGUE NEWS

Honda Motor Co., Ltd. Service Division

PARTS CATALOGUE - CORRECTED

Printed in Japan

CODE NO.	BOOKLET TYPE	13ZH81E0
	MICRO-FICHE	13ZH80EJ/FJ
PARTS CATALOGUE NEWS	GX160K1 GX160K1[PROPANE ENGINE]	
NEWS NO.	009	

Block No.	Ref. No.	Note	Part No.	Description	Reqd. QTY				Serial No.	Parts catalogue code	
					(1)	(2)	(3)	(4)			
<div style="border: 1px solid black; padding: 5px; display: inline-block;">PARTS NAME CORRECTED</div>											
E-14-2	11	Z	16100-ZH8-W51	CARBURETOR ASSY. (BE65B B/C)	1	-	1	-	-----	-----	HXE2, QBC2, QCB2, QCL, QGR9, Q12, QS2, QWA4, QWM2, QWX2, QWX3, QX22, QX7, RXE2, SMX4, SM12, SWX2, SWX4, SXS4, SX7, TCS2, VHA7, VIH1, VMS7, VSD7, VXE6, VXE7, WDA6
					1	-	-	-	4011428	-----	HG12, HH26, HX2, HX26, LAX2, LX2, LX26, PX2, QAX2, QBT2, QBT6, QBU2, QGR2, QH26, QMX2, QMZ2, QNT2, QXE2, QXE6, QXF2, QXS2, QXW2, QX2, QX26, RFR2, RHA2, RH2, RH26, RMG2, RTB2, SAD2, SG24, SMW2, SSK2, SSS2, TX2, TX26, VA2, VWA2, VW12, VXW2, VX2, VX26
					1	-	-	-	6276050	-----	HH, HHQ4, HX, HXE, HXE8, HXU, HX4, KTA, LH, LHB3, LHQ4, LSJ, LX, LXU, LX4, NW, PH, PHM, PX, PXU, QH, QHE, QHP1, QHQ4, QMC8, QMD6, QMH, QNT, QP, QPU, QX, QXB1, QXE, QXE4, QXE8, QXU, QXW, QX4, RH, RHQ4, RSK, RX, RXE, RXE4, RXU, RX4, SH, SHM, SHQ4, SMC7, SMC9, SMJ1, SM14, SSK1, STP, STQ, SX, SXE, SXE4, SXU, SX4, S1CY, TH, TX, TXU, TX4, UH, UX, UXU, VHH4, VMB3, VMS4, VS, VSD, VSX3, VTD, VTD1, VX, VXE4, VXG, VXM, VXU1, VX4

NOTE A:PART NO. CHANGE D:NEWLY PROVIDED E:PART NO.DELETION K:REQUIRED NO. CORRECTION L:APPLICATION SERIAL NO. CORRECTION
T:APPLICATION CORRECTION Z:REMARKS CHANGE



PARTS CATALOGUE NEWS

Honda Motor Co., Ltd. Service Division

PARTS CATALOGUE - CORRECTED

Printed in Japan

CODE NO.	BOOKLET TYPE	13ZH81E0
	MICRO- FICHE	13ZH80EJ/FJ
PARTS CATALOGUE NEWS	GX160K1 GX160K1[PROPANE ENGINE]	
NEWS NO.	010	

Block No.	Ref. No.	Note	Part No.	Description	Reqd. QTY				Serial No.	Parts catalogue code
					(1)	(2)	(3)	(4)		
					GX160K1					

PARTS NAME CORRECTED

E-7	5	Z	13310-ZE1-610	CRANKSHAFT COMP. (L=209.5) . . .	1	1	-	-	-----	DS, DSP, LAX, LAX2, LD, LDB1, LDB3, LDM, LD4, LH, LHB3, LHQ4 LHW, LJ, LJC7, LJD, LJG, LJS, LMT, LSJ, LSJ4, LSS, LSS1 LSS4, LTA, LTK, LVL, LW2, LX, LXU, LX2, LX26, LX4, L1
-----	---	---	---------------	----------------------------------	---	---	---	---	-------	--

NOTE A:PART NO. CHANGE D:NEWLY PROVIDED E:PART NO.DELETION K:REQUIRED NO. CORRECTION L:APPLICATION SERIAL NO. CORRECTION
T:APPLICATION CORRECTION Z:REMARKS CHANGE



PARTS CATALOGUE NEWS

Honda Motor Co., Ltd. Service Division

PARTS CATALOGUE - CORRECTED

Printed in Japan

CODE NO.	BOOKLET TYPE	13ZH81E0
	MICRO-FICHE	13ZH80EJ/FJ
PARTS CATALOGUE NEWS	GX160K1 GX160K1[PROPANE ENGINE]	
NEWS NO.	011	

Block No.	Ref. No.	Note	Part No.	Description	Reqd. QTY (1) (2) (3) (4)	Serial No.	Parts catalogue code
-----------	----------	------	----------	-------------	------------------------------	------------	----------------------

E-14-2 CARBURETOR (3)

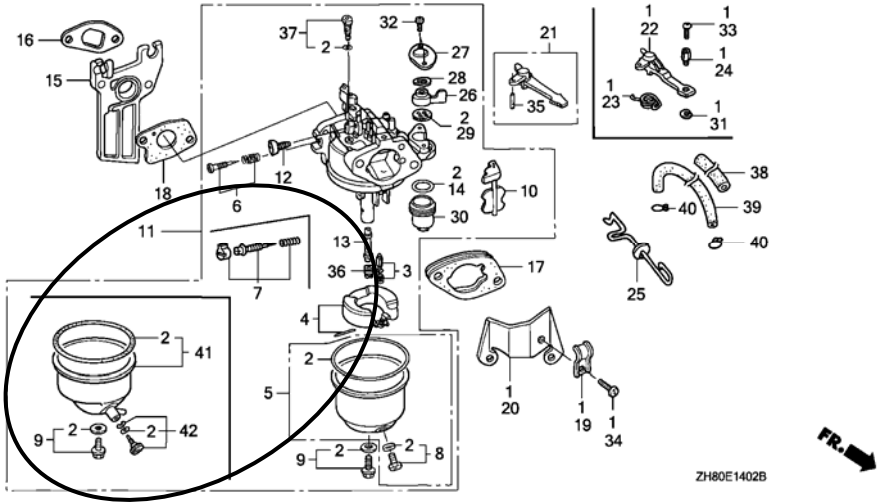

E-14-2 5 E 16015-ZH7-A20 *PARTS NO. DELETION

NOTE A:PART NO. CHANGE D:NEWLY PROVIDED E:PART NO.DELETION K:REQUIRED NO. CORRECTION L:APPLICATION SERIAL NO. CORRECTION
T:APPLICATION CORRECTION Z:REMARKS CHANGE

PARTS CATALOGUE NEWS

BOOKNo. : 13ZH81E0

Block No.	Ref. No.	Note	Part No.	Description	Reqd. QTY				Serial No.	Parts catalogue code
					(1)	GX160K1 (2)	(3)	(4)		
		E	16015-ZH7-A21	*PARTS NO. DELETION						
	8	E	16024-ZH7-A20	*PARTS NO. DELETION						
	41	D	16015-ZH7-A20	CHAMBER SET, FLOAT (CARBURETOR NO.)	1	-	-	-	----- BE06R A STM	
				(CARBURETOR NO.)	1	-	-	-	BE06R A BE06R A ST	
		D	16015-ZH7-A21 (CARBURETOR NO.)	1	-	-	-	BE06R B ----- ST, STM	
	42	D	16024-ZH7-A20	SCREW SET, DRAIN	1	-	-	-	----- ----- STM	
				(CARBURETOR NO.)	1	-	-	-	BE06R A ----- ST	

NOTE A:PART NO. CHANGE D:NEWLY PROVIDED E:PART NO.DELETION K:REQUIRED NO. CORRECTION L:APPLICATION SERIAL NO. CORRECTION
T:APPLICATION CORRECTION Z:REMARKS CHANGE