



634

TELEHANDLER

OPERATOR'S MANUAL

Revision C - 06/15

S/N 71102 - 71300

PART #913229



Mustang Manufacturing Company, Inc.

Indicator and Operation Symbols

					
Read Operator's Manual	Parking Brake	Brake Failure	Safety Alert	Turn Signals	Hazard Flasher
					
Ignition Off	Ignition ON	Engine Start	Hydraulic Oil	Horn	Engine Oil Pressure
					
Volume Full	Volume Half Full	Volume Empty	Battery	Fuel	Transmission Temperature
					
Engine Coolant Temperature	Starting Aid Injection	Wiper/Washer	Hourmeter	Lights	Work Lights
					
Fan	Clutch Disengaged	Clutch Engaged	Crab Steer	2-Wheel Steer	4-Wheel Steer
					
Raise Load	Lower Load	Tilt Rearward	Tilt Forward	Retract Load	Extend Load
					
Outriggers Up (right side shown)	Outriggers Down (right side shown)	Diesel Fuel	Frame Level Left	Frame Level Right	Engine Fault Shutdown Override

Table of Contents

Chapter	Description	Page
	International Symbols	Inside Front Cover
1	Introduction	2
2	Specifications	4
3	Check Lists	5
4	SAFETY	8
5	Indicators and Controls	23
6	Operation and Adjustments	30
7	Lubrication	43
8	Service and Storage	46
9	Decal Locations	61
10	Maintenance	66
	Hydraulic Schematics	70
	Electrical Schematics	74
	Load Zone Charts	76
	Standard Hardware Torque Data	78
	Index	79
	Warranty	Inside Back Cover

IDENTIFICATION INFORMATION

Write your Mustang telehandler Model and serial numbers below.
Refer to these numbers when inquiring about parts or service from your Mustang dealer.

MODEL NO.	634
SERIAL NO.	
ENGINE SERIAL NO.	

The model and serial numbers for this machine are on a decal located inside the operator's station.

Chapter 1

INTRODUCTION

The information in this Operator's Manual was written to give the owner/operator assistance in preparing, adjusting, maintaining and servicing of the Telehandler. More important, this manual provides an operating plan for safe and proper use of the machine. Major points of safe operation are detailed in the **SAFETY** chapter of this manual.

The Mustang Manufacturing Company asks that you read and understand the contents of this manual COMPLETELY and become familiar with the machine, before operating it.

This Telehandler is primarily intended for use as a material handler. However, it may be equipped with an optional system: the Work Platform Safety (WPS) System, which is intended for use when lifting personnel. When there is no other practical option available, this machine, when equipped with the WPS System, is approved for use to lift personnel, but only with an approved work platform, with the WPS System activated, and in full compliance with the "Mandatory Work Platform Safety Rules" (see SAFETY chapter).

The use of this Telehandler is subject to certain hazards that cannot be eliminated by mechanical means, but only by the exercise of intelligence, care and common sense. It is therefore essential to have competent and careful operators, who are not physically or mentally impaired, and who are thoroughly trained in the safe operation of the equipment and the handling of the loads.

Throughout this manual information is provided that is set in *italic* type and introduced by the word **IMPORTANT** or **NOTE**. Be sure to read carefully and comply with the message or directive given. Following this information will improve operating or maintenance efficiency, help to avoid breakdowns or damage, and extend the machine's life. A chart of standard hardware torques is located in the back of this manual.

A storage pocket on the back of the seat is provided for storing the Operator's Manual. After using the manual, please return it to the pocket and keep it with the unit at all times! If this machine is resold, Mustang Manufacturing Company recommends that this manual be given to the new owner.

If this machine was purchased "used," or if the owner's address has changed, please provide your Mustang dealer or Mustang Manufacturing Company Service Department with the owner's name and current address, along with the machine model and serial number. This will allow the registered owner information to be updated, so that the owner can be notified directly in case of an important product issue, such as a safety update program.

"Right" and "left" are determined from a position sitting on the seat and facing forward.

Our wide dealership network stands ready to provide any assistance required, including providing genuine Mustang service parts. All parts should be obtained from or ordered through your Mustang dealer. Give complete information about the part, and include the model and serial number of the machine. Record the serial number in the space provided on the previous page, as a handy record for quick reference.

Mustang Manufacturing Company reserves the right to make changes or improvements in the design or construction of any part without incurring the obligation to install such changes on any previously delivered unit.

Mustang, in cooperation with the Society of Automotive Engineers, has adopted this

Safety Alert Symbol

to identify potential safety hazards, which, if not properly avoided, could result in injury. When you see this symbol in this manual or on the machine itself, you are reminded to BE ALERT! Your personal safety is involved!



Identification

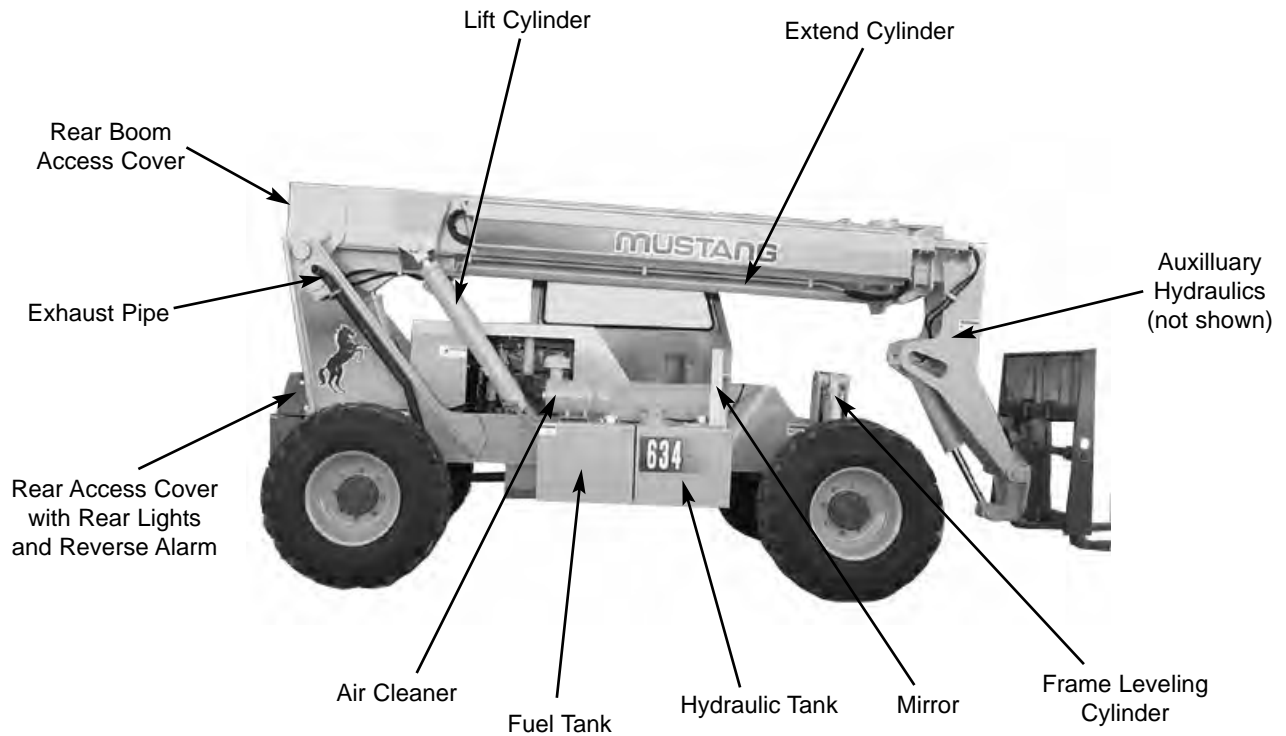
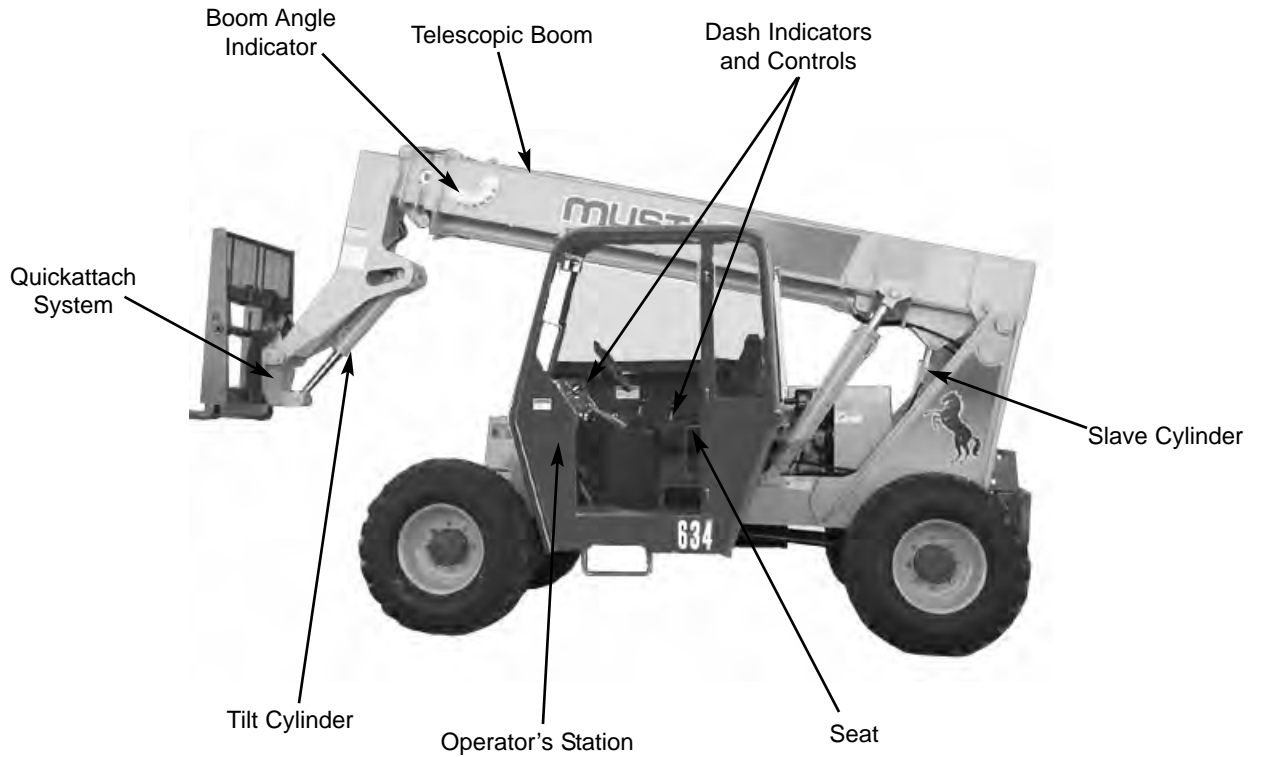

Chapter 2

SPECIFICATIONS

Lifting Performance

Maximum lift capacity:
6000 lbs. (2721 kg)

Maximum lift height:
34'-3" (10.44 m)

Capacity at maximum lift height:
4000 lbs. (1820 kg)

Max. forward reach to load center:
23'-3" (7.09 m)

Capacity at maximum forward reach:
900 lbs. (408 kg)

Maximum below grade reach:
24" (610 mm)

Frame Leveling:
10° left/10° right

General Dimensions

Based on standard machine equipped with listed tires, 48" masonry carriage and 48" pallet forks.

Recommended tire type:
15.00 x 19.5 12-ply
405/70 R 20 x M27 Traction Type

Overall length, less forks:
16'-0" (4.88 m)

Overall width:
7'-10" (2.39 m)

Overall height:
7'-9" (2.36 m)

Ground clearance: 14" (356 mm)

Wheel base: 9'-2" (2.8 m)

Outside turn radius: 12'-6" (3.81 m)

Machine weight:
15,100 lbs. (6855 kg)

Instrumentation

Gauges: Fuel level, hourmeter and coolant temperature

Monitoring lights:
Engine oil pressure, alternator, transmission oil temperature, brake failure

Visual indicators:
Boom angle, frame angle

Steering System

Steer Valve: Fixed displacement rotary
Displacement/Rev: 17.9 cu. in. (293 cc)
System pressure: 2000 psi (138 bar)
Steer cylinders: 1 per axle
Steer mode valve:
3-position, 4-way solenoid with dash-mounted switch actuation
Steer modes: 2-wheel, 4-wheel, crab

Braking System

Service brakes: Oil-immersed inboard hydraulic wet-disc type; separate front and rear systems;
Manual foot pedal actuation

Parking brake: Spring-applied, hydraulic-release disc-type in front axle

Actuation is electric switch with engine running, automatic with engine off.

Electrical System

Type: 12-volt, negative ground
Battery: 950 cold cranking amps
Circuit protection: Fuse panel
Backup alarm: 107 dB(A)
Horn: 111 dB(A)

Standard on all models:
Brake lights, rear backup light, neutral start switch

Alternator: 65-amp

Service Capacities

Cooling System: 17.2 qts. (16.3 L)
50/50 mixture
Anti-freeze protection: -34°F (-31°C)
Pressure cap: 10 psi (69 kPa)

Fuel tank: 29 gals. (110 L)
Hydraulic tank and system: 35 gals. (133 L)
Transmission and cooler: 24 qts. (22.7 L)

Axles:
Differentials: 9.6 qts. (9 L) ea.
Hubs: 0.6 qts. (0.5 L) ea.

Transmission

Type: Clark Powershift T12000
Speeds: 3 fwd / 3 rev

Torque converter:
Single-stage, dual-phase

Travel Speeds:
1st gear: 3.6 mph (5.8 km/h)
2nd gear: 7.9 mph (12.7 km/h)
3rd gear: 20.2 mph (32.5 km/h)

Axles (front and rear)

Type: Dana
Drive/steer, open differential, double reduction planetary, full-time four-wheel drive
Overall ratio: 15.4:1

Engine Options

Common to all options:
In-line 4-cycle, 4-cylinder, direct-injection diesel fuel system, in-line fuel filter w/water trap, positive pressure lubrication, liquid pressurized cooling system, 18" (457 mm) blower fan, dry single-element air cleaner, spin-on oil filter.

Turbocharged aspiration:
John Deere 4045T
276 cu. in. (4523 cc) displacement
99 hp (74 kW) @ 2500 rpm
Oil capacity: 14 qts. (13.3 L)

Turbocharged aspiration:
John Deere 4045T
276 cu. in. (4523 cc) displacement
115 hp (86 kW) @ 2500 rpm
Oil capacity: 14 qts. (13.3 L)

Hydraulic System

Type: Open-center
Pump: Single-section gear type

Displacement / revolution:
2.7 cu. in. (44.3 cc)

Flow @ 2500 RPM:
29 gpm (110 L/min)

Main relief pressure:
3000 psi (207 bar)

Steer relief pressure:
2000 psi (138 bar)

Hydraulic filter:
In-tank return type, 10 micron media, replaceable element.
Rated flow: 100 gpm (379 L/min)
Rated pressure: 100 psi (690 kPa)
By-pass pressure (full flow):
25 psi (172 kPa)

Hydraulic strainer:
In-tank suction, 149 micron media, replaceable element.
Rated flow: 50 gpm (189 L/min)
By-pass pressure: 3 psi (21 kPa)

Chapter 3

CHECKLISTS

PRE-DELIVERY

The following Checklist is an important reminder of inspections that **MUST** be made before delivering the Telehandler to the customer. Check off each item after prescribed action is taken.

✓ Check that:

- NO parts of machine have been damaged in shipment. Check for such things as dents and loose or missing parts; correct or replace components as required.
- Battery is securely mounted and not cracked. Cable connections are tight. Electrolyte at proper level.
- Cylinders, hoses and fittings are not damaged, leaking or loosely secured.
- Oil, fuel and air filters are not damaged, leaking or loosely secured.
- All grease fittings have been properly lubricated and no fittings are missing; see Lubrication chapter of this manual.
- Wheel nuts are torqued to 450 ft-lbs (610 Nm).
- Tires are inflated to 55 psi (380 kPa) cold.
- Hydraulic system reservoir, engine crankcase, engine coolant, transmission and axles are filled to the proper operating fluid levels.
- All adjustments have been made to comply with the settings given in this manual and in the separate engine manual.
- All guards, shields and decals are in place and securely attached.
- Model and serial numbers for this unit are recorded in space provided on this page and page 1.

Start the machine and test-run the unit while checking that proper operation is exhibited by all controls.

✓ Check that:

- All indicators (lamps, switches, etc.) function properly.
- All hand and foot controls operate properly.
- The WPS System operates properly (if equipped). Refer to Service and Storage chapter for the procedure to check the WPS System.
- Boom, Quick-attach System with attachment tool and frame level control all function properly.
- No hydraulic system leaks when under pressure.
- Listen for abnormal noises or vibrations; if detected, determine their cause and repair as necessary.

I acknowledge that the pre-delivery procedures were performed on this unit as outlined above.

Dealership's Name

Dealer Representative's Name

Date Checklist Filled Out

Machine Model #

Machine Serial #

Engine Serial #

DELIVERY

✓ Check that:

The following Checklist is an important reminder of valuable information that **MUST** be passed on to the customer at the time the unit is delivered. Check off each item as you explain it to the customer.

- Review with the customer the contents of the AEM Safety Manual for the following:
 - The *Index* at the back, for quickly locating topics;
 - The Safety, Indicators and Controls, and Operation and Adjustments chapters for information regarding safe use of the machine.
 - The Lubrication, Service and Storage chapters for information regarding proper maintenance of the machine. Explain that regular lubrication and maintenance are required for continued safe operation and long life.
- Give this Operator's Manual and the AEM Safety Manual to the customer and instruct them to be sure to read and completely understand their contents before operating the unit.
- Remind the customer of U.S. OSHA regulation 1910.178 (I), which specifies operator training requirements.
- Explain that the customer must consult the engine manual (provided) for related specifications, operating adjustments and maintenance instructions.
- Completely fill out the Owner's Registration, including customer's signature, and return it to the Company.

Customer's Signature

Date Delivered

(Dealer's File Copy - Remove at Perforation)

INTENTIONALLY BLANK

(To be removed as Dealer's file copy)

Chapter 3

CHECKLISTS

PRE-DELIVERY

The following Checklist is an important reminder of inspections that **MUST** be made before delivering the Telehandler to the customer. Check off each item after prescribed action is taken.

✓ Check that:

- NO parts of machine have been damaged in shipment. Check for such things as dents and loose or missing parts; correct or replace components as required.
- Battery is securely mounted and not cracked. Cable connections are tight. Electrolyte at proper level.
- Cylinders, hoses and fittings are not damaged, leaking or loosely secured.
- Oil, fuel and air filters are not damaged, leaking or loosely secured.
- All grease fittings have been properly lubricated and no fittings are missing; see Lubrication chapter of this manual.
- Wheel nuts are torqued to 450 ft-lbs (610 Nm).
- Tires are inflated to 55 psi (380 kPa) cold.
- Hydraulic system reservoir, engine crankcase, engine coolant, transmission and axles are filled to the proper operating fluid levels.
- All adjustments have been made to comply with the settings given in this manual and in the separate engine manual.
- All guards, shields and decals are in place and securely attached.
- Model and serial numbers for this unit are recorded in space provided on this page and page 1.

Start the machine and test-run the unit while checking that proper operation is exhibited by all controls.

✓ Check that:

- All indicators (lamps, switches, etc.) function properly.
- All hand and foot controls operate properly.
- The WPS System operates properly (if equipped). Refer to Service and Storage chapter for the procedure to check the WPS System.
- Boom, Quick-attach System with attachment tool and frame level control all function properly.
- No hydraulic system leaks when under pressure.
- Listen for abnormal noises or vibrations; if detected, determine their cause and repair as necessary.

I acknowledge that the pre-delivery procedures were performed on this unit as outlined above.

Dealership's Name

Dealer Representative's Name

Date Checklist Filled Out

Machine Model #

Machine Serial #

Engine Serial #

DELIVERY

✓ Check that:

The following Checklist is an important reminder of valuable information that **MUST** be passed on to the customer at the time the unit is delivered. Check off each item as you explain it to the customer.

- Review with the customer the contents of the AEM Safety Manual for the following:
 - The *Index* at the back, for quickly locating topics;
 - The Safety, Indicators and Controls, and Operation and Adjustments chapters for information regarding safe use of the machine.
 - The Lubrication, Service and Storage chapters for information regarding proper maintenance of the machine. Explain that regular lubrication and maintenance are required for continued safe operation and long life.
- Give this Operator's Manual and the AEM Safety Manual to the customer and instruct them to be sure to read and completely understand their contents before operating the unit.
- Remind the customer of U.S. OSHA regulation 1910.178 (I), which specifies operator training requirements.
- Explain that the customer must consult the engine manual (provided) for related specifications, operating adjustments and maintenance instructions.
- Completely fill out the Owner's Registration, including customer's signature, and return it to the Company.

Customer's Signature

Date Delivered

(Pages 5 and 6 have been removed at perforation)

Chapter 4



SAFETY



The above Safety Alert Symbol means **ATTENTION! ALWAYS BE ALERT! YOUR SAFETY IS INVOLVED!** It stresses an attitude of “Heads Up for Safety” and can be found throughout this Operator’s Manual and on the machine itself.

Before operating this equipment, read and study the following safety information. In addition, be sure that everyone who operates or works with this equipment is familiar with these safety precautions.

DANGER

“**DANGER**” indicates an imminently hazardous situation which, if not avoided, will result in death or serious injury.

WARNING

“**WARNING**” indicates a potentially hazardous situation which, if not avoided, could result in death or serious injury.

CAUTION

“**CAUTION**” indicates a potentially hazardous situation which, if not avoided, may result in minor or moderate injury. It may also alert to unsafe practices.

Mustang Manufacturing Company **ALWAYS** takes the operator’s safety into consideration when designing its machinery, and guards exposed moving parts for his/her protection. However, some areas cannot be guarded in order to assure proper operation. Further, this Operator’s Manual and decals on the machine warn of additional hazards and should be read and observed closely.

REMEMBER! It is the owner’s responsibility for communicating information on the safe use and proper maintenance of this machine! This includes providing understandable interpretations of these instructions for operators who are not fluent in reading English.

It is the responsibility of the operator to read and understand the Operator’s Manual and other information provided and use the correct operating procedure. Machines should be operated only by qualified operators.

MANDATORY SAFETY SHUTDOWN

PROCEDURE

BEFORE cleaning, adjusting, lubricating or servicing the unit:

1. Stop machine on a level surface. (**AVOID** parking on a slope, but if necessary, park across the slope and block the tires.)
2. Fully retract the boom and lower the attachment tool to the ground. Idle engine for gradual cooling.
3. Place controls in neutral and apply parking brake.
4. Shut off the engine and remove the key.

ONLY when you have taken these precautions can you be sure it is safe to proceed. Failure to follow the above procedure could lead to death or serious bodily injury.



SAFETY



WARNING

U.S. OSHA regulations require employers in general industry and the construction, shipyard and cargo-handling industries (excepting agricultural operations) to ensure that forklift operators are competent, as demonstrated by successful completion of a training course.

The training course must consist of a combination of formal instruction and practical training, including both forklift-related and workplace-related topics, and evaluation of the operator's performance in the workplace.

All operator training and evaluation is to be conducted by persons who have the knowledge, training and experience to train and evaluate operators.

WARNING

ALWAYS maintain a safe distance from electric power lines and avoid contact with any electrically charged conductor or gas line. It is not necessary to make direct contact with a power line for power to ground through the structure of the machine. Keep the boom at least 10 ft. (3 m) from all power lines. Accidental contact or rupture can result in electrocution or an explosion. Contact the North American One-Call Referral System at (888) 258-0808 for the local "Digger's Hotline" number or proper local authorities for utility line locations **BEFORE** starting to dig!

Additional Safety Reminders

- User/operator safety practices, as established by industry standards, are included in this Operator's Manual and intended to promote safe operation of the machine. These guidelines do not, of course, preclude the use of good judgment, care and common sense as may be indicated by the particular jobsite work conditions.
- It is essential that operators be physically and mentally free of mind altering drugs and chemicals and thoroughly trained in the safe operation of the machine. Such training should be presented completely to all new operators and not condensed for those claiming previous experience. Information on operator training is available from several sources, including the manufacturer.
- Some illustrations used in this manual may show doors, guards and shields open or removed for illustration purposes **ONLY**. **BE SURE** that all doors, guards and shields are in their proper operating positions **BEFORE** starting the engine.

Before Operation Safety Reminders

- Check brakes, steering, and hydraulic system prior to starting operation. Operate all controls to ensure proper operation. Observe all gauges and indicators for proper operation. If any malfunctions are found, correct the cause prior to using the machine.
- **ALWAYS** wear appropriate personal protective equipment for the job and working conditions. Hard hats, goggles, protective shoes, gloves, reflector-type vests, respirators and ear protection are examples of types of equipment that may be required. **DO NOT** wear loose fitting clothing, long hair, jewelry or loose personal items while operating or servicing the machine.
- **ALWAYS** check the job site for terrain hazards, obstructions and people. Remove all objects that do not belong in or on the machine and its equipment.



SAFETY



- Walk around the machine and warn all personnel who may be servicing the machine or who are in the machine path prior to starting. **DO NOT** start until all personnel are clearly away from the machine.

Operation Safety Reminders

- Any or all of the following factors may affect the stability of the machine: terrain, engine speed, type of load being carried and placed, improper tire inflation, weight of the attachment tool, and abrupt movement of any control lever. **IF YOU ARE NOT CAREFUL WHILE OPERATING THIS MACHINE, ANY OF THE ABOVE FACTORS COULD CAUSE THE MACHINE TO TIP AND THROW YOU OUT OF THE OPERATOR'S STATION, WHICH MAY CAUSE SERIOUS BODILY INJURY OR DEATH!**
- **ALWAYS** wear the seat belt provided to prevent being thrown from the machine. If you are in an overturn:
 - **DO NOT** jump!
 - Hold on tight and stay with the machine!
 - Lean away from the fall!
- **ALWAYS** keep hands, feet and arms inside of the operator's station when operating the machine!
- Always look in the direction of travel. Look to the rear before backing.
- **ALWAYS** use the recommended hand holds and steps with at least three points of support when getting on and off the machine. Keep steps and platform clean. Face the machine when climbing up and down.
- **DO NOT** raise or drop a loaded fork or bucket suddenly. Abrupt movements under load can cause serious instability.
- Study the load chart carefully. It shows maximum capacity to be lifted and placed at specific outward and upward distances. **ALWAYS** be aware of load weights prior to attempting lift and placement with this machine.
- **DO NOT** exceed the machine's rated operating capacity for the type of attachment tool being used.
- **DO NOT** allow minors or any unqualified personnel to operate or be near the machine unless properly supervised.
- **DO NOT** start the engine or operate any controls unless properly seated in the operator's seat!
- **DO NOT** run the engine in an enclosed area without providing proper ventilation for the exhaust. Exhaust gases contain carbon monoxide, an odorless and deadly gas. Internal combustion engines deplete the oxygen supply within enclosed spaces and may create a serious hazard unless the oxygen is replaced. This includes the atmosphere within the cab when equipped.
- **DO NOT** leave the operator's station with the boom and attachment tool raised. **ALWAYS** lower the boom and attachment tool to the ground, shut off the engine and engage the parking brake before leaving the operator's station.
- **DO NOT** drive too close to an excavation or ditch. **BE SURE** that the surrounding ground has adequate strength to support the weight of the machine and the load it is carrying.
- **DO NOT** turn quickly while traveling on a slope or operate the machine beyond the grade and slope limits noted in the **OPERATION AND ADJUSTMENTS** chapter of the Operator's Manual.
- **NEVER** allow any riders on this machine. This is strictly a single seat, **NO** passenger machine
- **NEVER** use as a lift for personnel unless the machine is equipped with the **Work Platform Safety (WPS) System**.
- When road travel is required, know and use the signaling devices on the machine. Provide an escort and Slow-Moving Vehicle (SMV) emblem when required.
- If necessary to park on a slope, park across the slope and block the wheels.



SAFETY



Servicing Safety Reminders

- ➔ ALWAYS be aware of and avoid pinch point areas on the machine, such as wheels-to-frame, cylinders-to-frame, boom and attachment tool-to-frame.
 - ➔ NEVER attempt to by-pass the keyswitch to start the engine. ONLY use the jump-starting procedure detailed in the SERVICE AND STORAGE chapter.
 - ➔ NEVER use your hands to search for hydraulic fluid leaks. Instead use a piece of paper or cardboard. Escaping fluid under pressure can be invisible and can penetrate the skin, causing serious injury. If any fluid is injected into your skin, see a doctor at once. Injected fluid MUST be surgically removed by a doctor familiar with this type of injury or gangrene may result.
 - ➔ ALWAYS wear safety glasses with side shields when striking metal against metal. In addition, it is recommended that a softer (chip-resistant) material be used to cushion the blow. Failure to heed could lead to serious injury to the eyes or other parts of the body.
 - ➔ DO NOT refill the fuel tank when the engine is hot. Allow engine to cool down before refilling to prevent hot engine parts from igniting the fuel if it should spill or splash.
 - ➔ DO NOT smoke while filling the fuel tank, working on the fuel or hydraulic systems, or working around the battery.
 - ➔ DO NOT fill the fuel tank completely. Allow room for expansion. Maintain control of the fuel filler nozzle when filling the tank. Use the correct fuel grade for the operating season.
 - ➔ NEVER use fuel for cleaning purposes.
 - ➔ DO NOT remove the radiator cap after the engine has reached operating temperature or if it is overheated. At operating temperatures, the engine coolant will be extremely HOT and under pressure.
- ALWAYS wait for the engine to cool down before attempting to relieve pressure and remove the radiator cap. Failure to heed this warning could result in severe burns.
- ➔ DO NOT loosen or disconnect any hydraulic lines, hoses or fittings without first relieving hydraulic circuit pressure. Also, be careful not to touch any hydraulic components that have been in recent operation because they can be extremely hot and can burn you!
 - ➔ Avoid lubrication or mechanical adjustments with the machine in motion or the engine running. If the engine must be running to make certain adjustments, place the transmission in neutral, apply the parking brake, place the equipment in a safe position, securely block the wheels and use extreme caution.
 - ➔ To ensure continued safe operation, replace damaged or worn-out parts with genuine Mustang service parts before using this equipment.

Modifications, Nameplates, Markings and Capacities

- ➔ Modifications and additions that affect capacity or safe operation must never be performed without the manufacturer's prior written approval. Where such authorization is granted, any applicable markings are to be changed accordingly.
- ➔ All attachment tools MUST be marked to identify the attachment tool and the total capacity with the attachment tool at maximum elevation with the load laterally centered.
- ➔ ALWAYS be sure all nameplates, warnings and instruction markings are in place and legible. Local government regulations may require specific decals, which are the responsibility of the owner to provide.



SAFETY



Safety Guards and Warning Devices

- ➔ This machine is fitted with a Roll-Over Protective Structure (ROPS) and Falling Object Protective Structure (FOPS) in accordance with industry standards. It is intended to offer protection to the operator from falling objects and in case of an overturn, but it cannot protect against every possible hazard. Therefore it should not be considered a substitute for good judgment and safe practices in operating the machine. If the ROPS / FOPS structure is damaged, it must be replaced to restore the protection it provides.
- ➔ This machine is equipped with a horn and backup alarm. The user must determine if operating conditions require the machine to be equipped with additional devices (mirrors, rotating beacon, etc.) and be responsible for providing and maintaining such devices.

Work Platform Safety System



The machine must not be used to lift or carry personnel, or be fitted with any form of personnel work platform unless fitted with the optional WPS System.

If fitted with the WPS System, the Mandatory Work Platform Safety Rules must be followed at all times while lifting personnel.

The Mandatory Work Platform Safety Rules must be adhered to at all times while elevating personnel. These rules are based on ANSI/ITSDF Standard B56.6-2005, "Safety Standard for Rough Terrain Forklift Trucks." (A copy of this and related standards can be obtained from the Industrial Truck Standards Development Foundation, 1750 K Street NW, Suite 460, Washington DC 20009; or downloaded from: www.itsdf.com.) The rules apply to the owner, operator and the personnel in the work platform.

MANDATORY WORK PLATFORM SAFETY RULES

1. The work platform must comply with ANSI/ITSDF B56.6-2005, Sec. 8.24, "Platforms for Elevating Personnel." (See page 13, "Work Platform Design Requirements.")
2. The platform must be securely attached to the carriage or forks, and the carriage securely attached to the boom.
3. The carriage and forks must be secured to prevent them from pivoting upward.
4. If the machine is equipped with a rotating or swinging carriage, the rotation or swing must be deactivated. (This occurs automatically when the "WPS System" is switched on.)
5. Personnel on the platform must be provided protection from any moving parts on the forklift that may present a hazard.
6. If overhead hazards exist for platform personnel, overhead protection must be provided.
7. Be sure that the lifting mechanism is operating smoothly throughout its entire range, both empty and loaded, and that any lift-limiting devices and latches are functional.
8. Be sure that the frame is level, to ensure a vertical lift.
9. Be sure the platform is horizontal before lifting.
10. Be sure that the forklift has a firm footing.
11. Be sure that any required restraining means (railings, chains, harnesses, etc.) are in place and properly used.
12. Before lifting personnel, shift the transmission into Neutral, apply the parking brake, and activate the "WPS System" mode switch.
13. Before lifting personnel, the area should be marked to warn others of work by elevated personnel.



SAFETY



14. Be sure the path of platform travel is clear of hazards, such as scaffolds, electrical wires and overhead obstructions.
15. The operator must keep hands and feet clear of controls that are not in use.
16. Personnel must be lifted and lowered smoothly and cautiously, and only at their request.
17. The platform must be lowered fully before moving the forklift. Do not drive the forklift with personnel on the platform.
18. Elevated personnel must always be alerted before raising or lowering the platform.
19. A trained operator must be in position to operate the forklift and boom controls at all times.
20. The combined weight of the platform, personnel and load must not exceed one-third of the material-handling capacity of the forklift.
21. Platform personnel must maintain firm footing on the platform floor, unless secured by harness and lanyard. A harness is to be worn and a lanyard attached to the platform or boom when working from an elevated work platform, in accordance with OSHA regulations. Use of railings, planks, ladders, etc. on platform for the purpose of achieving additional reach or height is prohibited.
22. Workers on the platform must keep all parts of their bodies inside the work platform during raising and lowering.
23. Be sure that the personnel and equipment on the platform do not exceed the available space.
24. The platform must be fully lowered for personnel to enter and exit. Personnel must not climb on any part of the forklift in attempting to enter and exit.
25. Any harness, body belt, lanyard, or deceleration device that has sustained permanent deformation or is otherwise damaged must be replaced.
26. Modifications to the platform that are detrimental to its safe use are prohibited.



WARNING

Use **ONLY** an approved work platform for elevating personnel.

NEVER move the machine with the work platform in a raised position or with personnel on board.

NEVER tilt the platform forward, rearward, or to the side with personnel aboard.

ALWAYS engage the WPS System and follow the Mandatory Work Platform Safety Rules when elevating personnel.

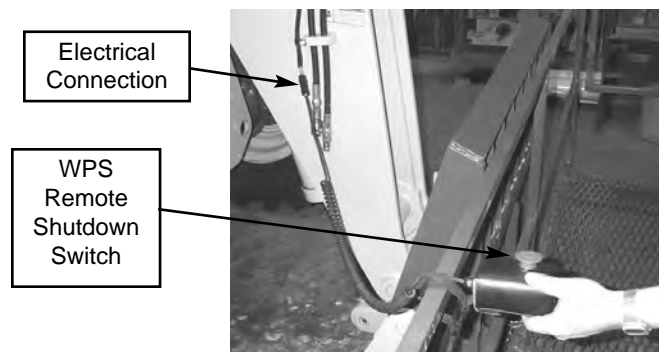
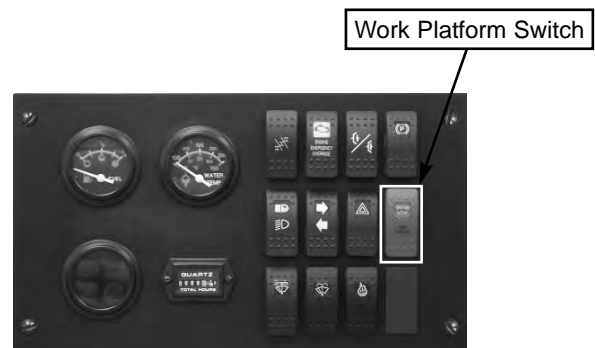

Remote Shutdown Switch
With Coiled Wire Connector



SAFETY



Work Platform Design Requirements (Per ANSI/ITSDF B56.6-2005, Sec. 8.24)

1. A platform floor having a slip-resistant surface located not more than 8 inches (200 mm) above the normal load supporting surface of the forks.
2. Floor dimensions, which shall not exceed two times the load center distance of 24 inches (610 mm) listed on the forklift nameplate, measured parallel to the longitudinal center plane of the truck, nor have a width greater than the overall width of the forklift [measured across the load-bearing tires] plus 10 inches (250 mm) on either side. Minimum space for each person on the platform shall not be less than 18 inches (450 mm) in either direction.
3. A 4 inch (100 mm) minimum height toe plate, which may be omitted at the access opening.
4. An overhead protective device, when requested by the user.
5. Protection for personnel in their normal working position on the platform from moving parts of the forklift that may present a hazard.
6. Information prominently indicated on the platform:
 - a. maximum work load including personnel and equipment, and
 - b. weight of empty platform.
7. Means so that the platform can only be centered laterally on the forklift, and retained against the vertical face of the forks, carriage, or lifting mechanism.
8. A means to securely attach the platform to the lifting mechanism, and to prevent the platform from inadvertently pivoting.
9. Restraining means such as a guardrail or a means for securing personnel such as a body harness and lanyard. A guardrail or similar structure shall have a nominal height to the platform floor of 42 inches (1066 mm) around its upper periphery and include a midrail. It may be hinged, removable, or of chains, and used to provide an access opening if proper positioning is easily accomplished and a secure condition is discernable. Such restraining means shall be capable of withstanding a concentrated horizontal force of 200 lb. (890 N) applied at the point of least resistance without permanent deformation. A body harness and lanyard is to have an attachment point provided overhead for freedom of movement, and its length is to limit free-fall to 5 feet (1500 mm) measured from the point of attachment to the operator. The complete system shall be capable of withstanding three consecutive drop tests to simulate a 250 lb. (113 kg) person falling 6 feet (1800 mm) without allowing the test weight to fall free to the ground. A deceleration device may be included.

NOTE: *Fall protection should comply with applicable U.S. OSHA regulations: 1910.67 (c)(2)(v) (for General Industry) or 1926.453 (b)(2)(v) (for Construction).*

10. Lanyards, when provided, shall be arranged so as not to cause a tripping hazard.
11. Body harnesses, when provided, should have a width of at least 1.75 inches (44 mm).
12. Structural safety factor - all load supporting structural elements of the work platform shall have a structural safety factor of not less than 2 to 1 based on the minimum yield strength of the materials used.



SAFETY



▲ WARNING



OVERTURN HAZARD
Always fasten seatbelt.
Inspect worksite to be sure ground is stable.

Before raising boom:

- Consult load charts.
- Apply park brake.
- Shift into Neutral.
- Level frame.

DO NOT exceed rated capacity.

DO NOT position load using frame leveling.

DO NOT move machine with boom raised.

DO NOT transport load with job boom or winch.

To avoid rear overturn, **DO NOT** tilt job boom or winch back more than 45° when main boom is raised above 45°.

If machine overturns, **DO NOT** jump. Instead, hold on tight and lean away from fall.

L70306

L70306

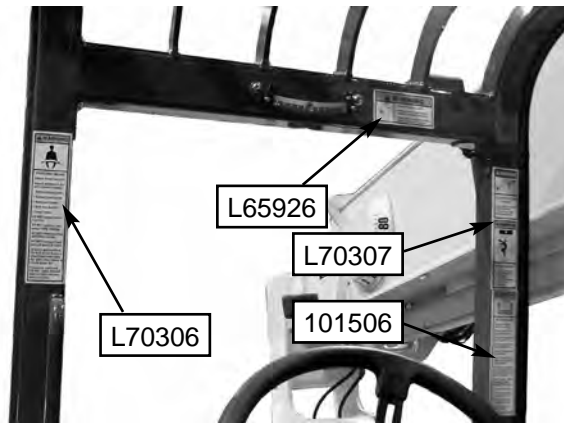

▲ WARNING

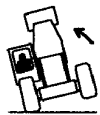

- **CARRY LOAD LOW!**
- Retract and lower boom before moving machine.
- Stay within stability limits. See Operator's Manual.

L65926

L65926

▲ DANGER



ELECTROCUTION HAZARD
Keep machine, boom and load 10 feet (3 m) or more away from power lines.

▲ WARNING



CRUSH HAZARD

- **DO NOT** remove right side window or panel.
- Replace if broken, damaged or missing.

L70307

L70307

▲ WARNING



RUN-OVER HAZARD
No riders!

L65932

L65932



▲ WARNING



TO AVOID INJURY
Inspect machine before operating it.
Be sure work tool is securely attached.
Start and operate only from operator's seat.
Use 2-wheel steer for high speed travel.
Be sure backup alarm is functioning.
Look in direction of travel and clear path before moving.
DO NOT use hands to find oil leak -- oil can inject into skin. See a doctor if injured.

Before exiting, follow Mandatory Safety Shutdown Procedure:

- 1) Stop in level area;
- 2) Fully retract boom, lower work tool;
- 3) Shift into Neutral, apply park break;
- 4) Shut off engine, remove key.

L101506

L101506



SAFETY

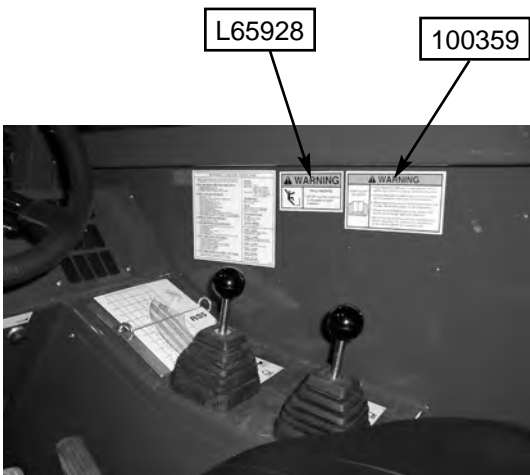
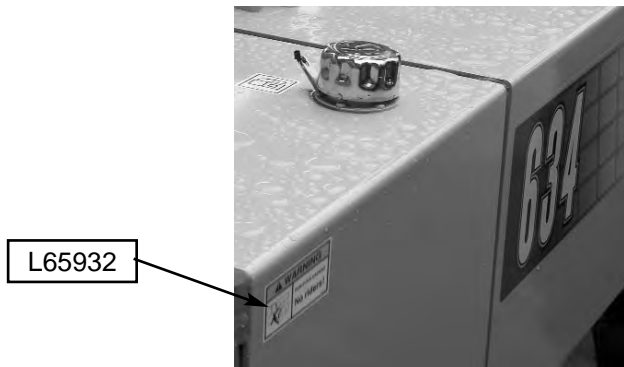
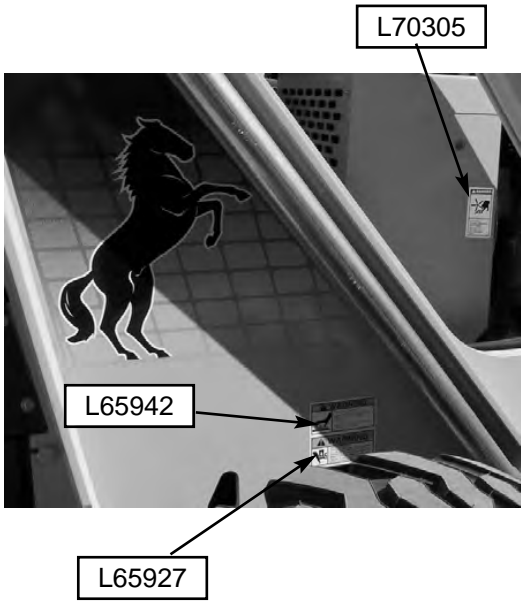



SAFETY



L65928

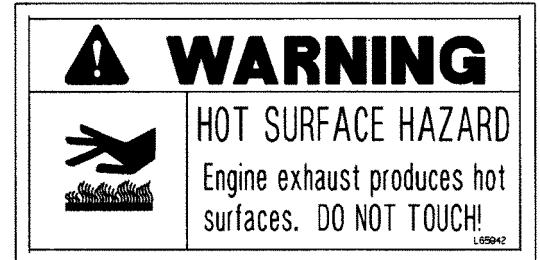

L65942

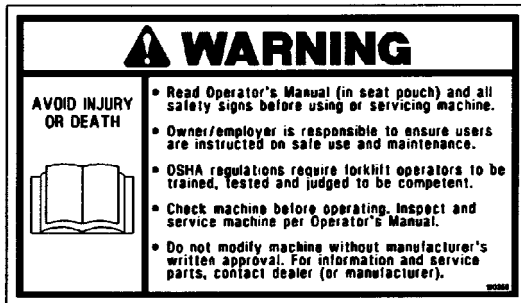

100359

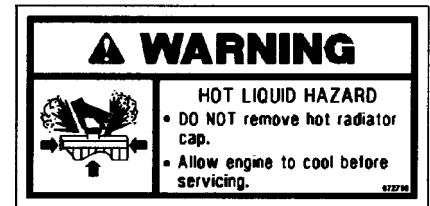

072798



L65932



L65927

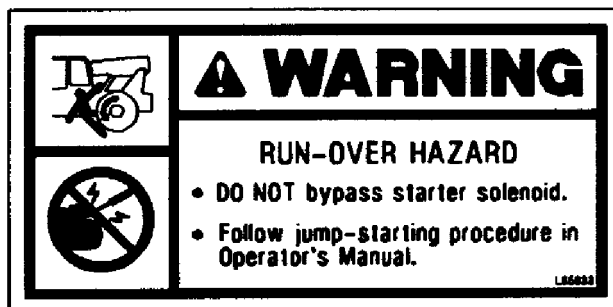

L65933



L70305



SAFETY

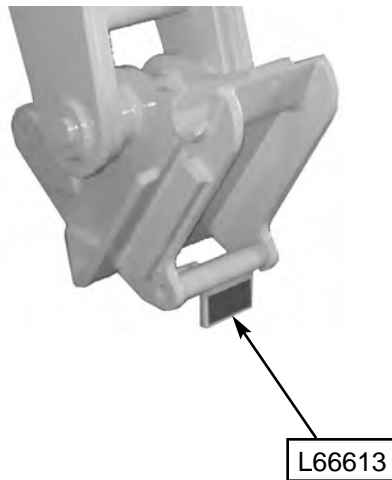
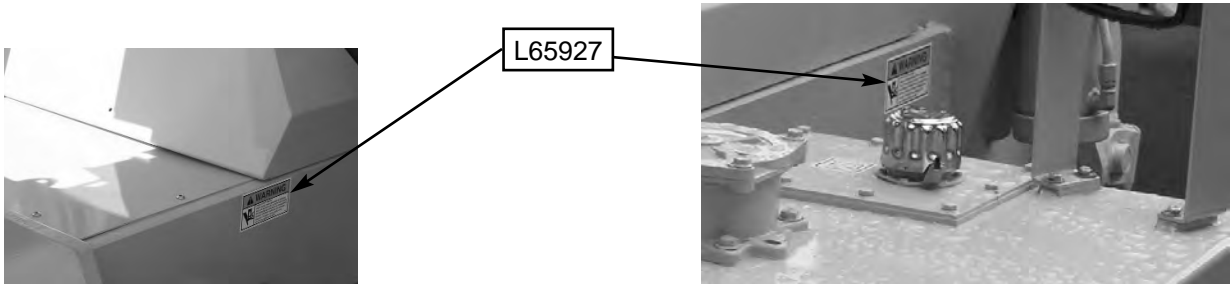
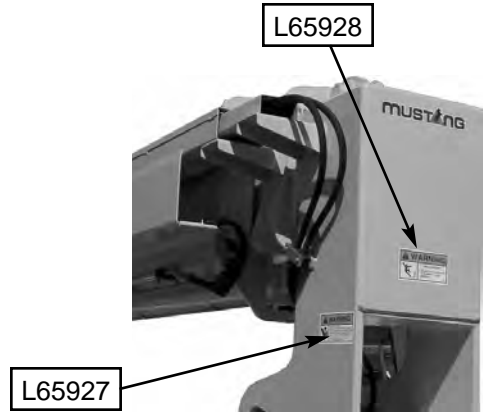
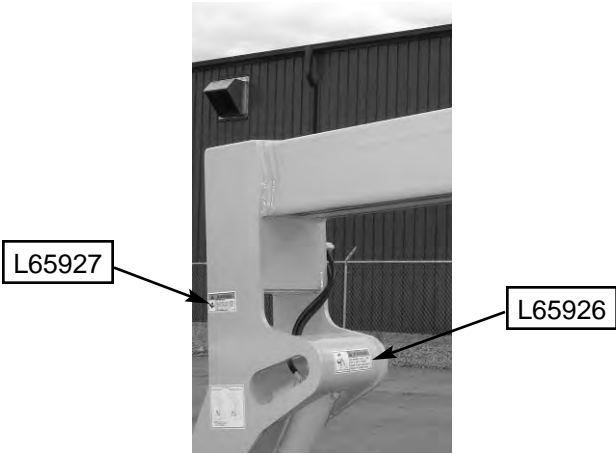



SAFETY



L65928

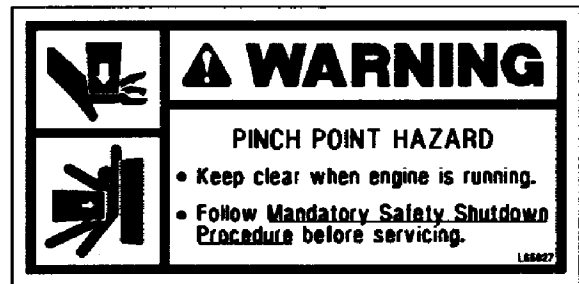

L65927



L65926



L66613



SAFETY



WPS System Decals

L71554



L71555

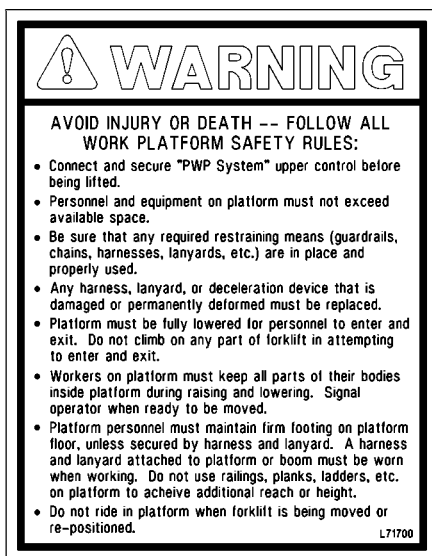
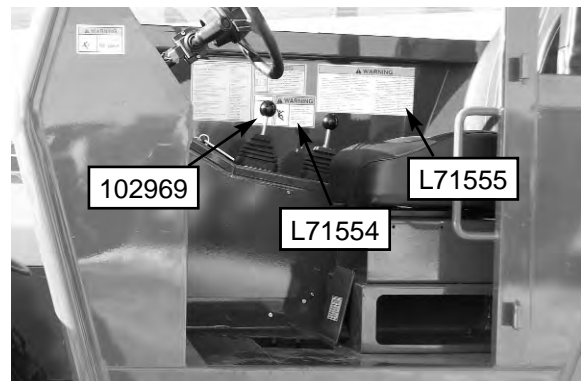
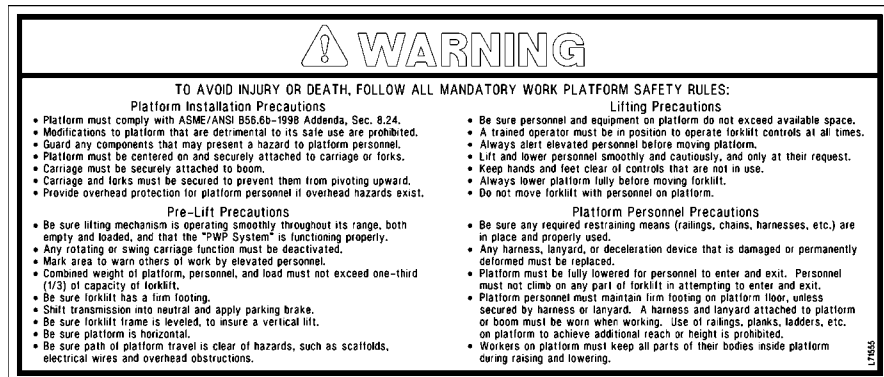

L71700

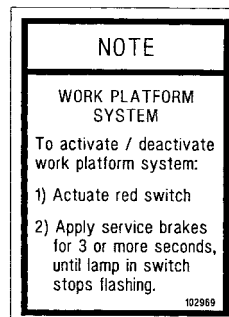

102969

Chapter 5

INDICATORS AND CONTROLS

CAUTION

Become familiar with and know how to use ALL safety devices and controls on the Telehandler BEFORE operating it. Know how to stop the machine operation BEFORE operating it. This Mustang machine is designed and intended to be used ONLY with a Mustang attachment tool, or a Mustang approved accessory or referral attachment tool. Mustang cannot be responsible for safety if the machine is used with an unapproved accessory or attachment tool.

GUARDS AND SHIELDS

Whenever possible and without affecting machine operation, guards and shields are used to protect potentially hazardous areas. In many places, decals are also provided to warn of potential hazards and to display special operating procedures.

WARNING

Read and thoroughly understand all safety decals on the Telehandler BEFORE operating it. DO NOT operate the machine unless all factory-installed guards and shields are properly secured in place.

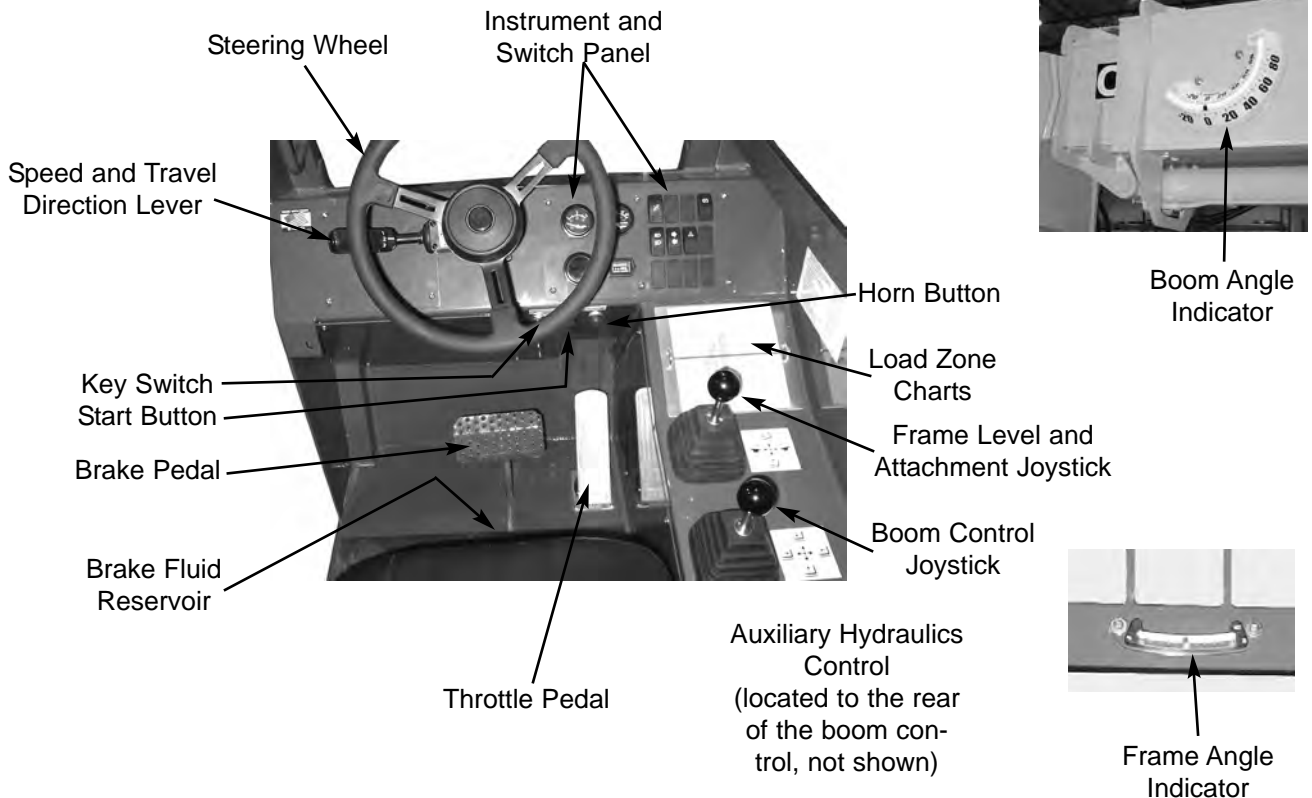

Operator's Compartment and Indicators/Controls Locations

DASH PANEL AREA

Key Switch OFF: When the key is vertical in the keyswitch, power from the battery is disconnected to the control and instrument panel electrical circuits. Also, this is the only position in which the key can be inserted or removed.



Key Switch ON: When the key is turned one position clockwise from the vertical (OFF) position, power from the battery is supplied to all control and instrument panel electrical circuits.



NOTE: If the engine requires repeated attempts to start, the key **MUST** be returned to the OFF position between starting attempts to prevent battery run down.

Start Button: With key switch in ON position, press the button to activate the starter. Release it as soon as the engine starts.



Horn Button: With the key switch ON, press the horn button to activate warning sound.



Load Zone Charts: A series of flip charts show lift height and reach limits relative to the load weight being handled with various attachment tools.



Instrument and Switch Panel

Fuel Level Gauge: The upper left gauge in the instrument panel, it indicates the amount of fuel remaining in the fuel tank.



Coolant Temperature Gauge: The upper right gauge in the instrument panel, it indicates the temperature of the engine coolant. Under normal conditions, this gauge should indicate approximately 185°F (85°C).



Lamp Cluster Gauge: The lower left gauge in the instrument panel, it contains four indicator lamps. The functions of these lamps are as follows:



Alternator Lamp: Located in the upper left section of the lamp cluster gauge, this lamp indicates the condition of the electrical charging system. During normal operation, this lamp should be off. If the charge rate is too high or too low, this lamp will come on.

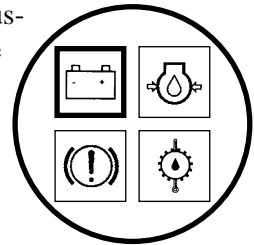

Engine Oil Pressure Lamp: Located in the upper right section of the lamp cluster gauge, this lamp indicates whether the engine lubricating oil pressure is sufficient. During normal operation, with the engine running, this lamp should be off. During starting and when the engine is not running, this lamp will be on.

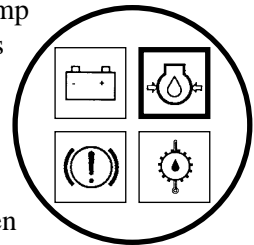

IMPORTANT: If this lamp comes on during normal operation with the engine running, stop the engine immediately! After allowing the oil to drain down for a few minutes, check the engine oil level. Maintain oil level at the FULL mark on the dipstick.

Brake Failure Lamp: Located in the lower left section of the lamp cluster gauge. The front and rear brakes are on independent brake systems. If during normal operation with the brake pedal depressed, a loss of pressure occurs in either system, the brake failure lamp comes on.

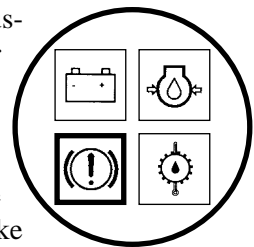

Failure in one of the brake systems does not affect the operation of the other system. However, the **MANDATORY SAFETY SHUTDOWN PROCEDURE (p. 8)** should be followed and any required repairs made immediately.

During normal operation this lamp should remain off.

Transmission Oil Temperature Lamp:

Located in the lower right section of the lamp cluster gauge, this lamp indicates whether or not the transmission oil is at the proper temperature. During normal operation this lamp should be off, indicating that the transmission oil system is at the proper temperature.

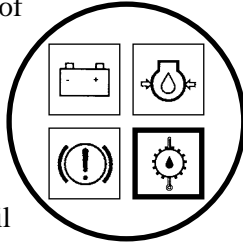

IMPORTANT: *If this lamp comes on during normal operation, a problem may exist in the transmission oil system. Stop the machine immediately and investigate the cause of the problem!*

Hourmeter: Located to the right of the lamp cluster gauge, it indicates the total operating time of the machine. It should be used for keeping the maintenance log.



Top Row Switches

Switches have graphic symbols to indicate position and response. The following mode descriptions start with the first switch on the left.

NOTE: *Some switches are optional and may not be on machine.*

Steer Selector: This 3-position switch is used to select among the three steer modes. The upper position selects the 4-wheel steer mode. This mode engages all-wheel steering, for making tighter turns, usually on a jobsite. The center position selects the 2-wheel steer mode. This mode engages front wheel steering only, used for higher speed travel. The lower position selects the crab steer mode. This mode is used when a small amount of side shift is needed for picking or placing a load.

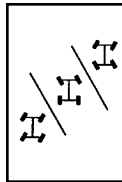

NOTE: *The rear wheels are not self-centering. Make sure all wheels are in a straight ahead position before changing the steer mode.*

Any of the steering position modes can be used in forward and reverse travel. The operator should learn to anticipate changes in machine movement if the steering selector mode must be changed.

Engine Fault Shutdown Override

Switch: Pressing the shutdown override switch will override an engine shutdown signal. The switch must be pressed within 30 seconds to prevent undesired shutdown of engine. The switch can be overridden for 30 seconds at a time to move the machine to a safe location and to lower the boom to the ground. If the engine shuts down, the ignition switch must be turned off and then back on before the engine can be restarted.



NOTE: *Holding the switch continuously "ON" will not reset the 30-second timer.*

NOTE: *Only machines equipped with the engine shutdown protection have this switch. These machines also have the electronic throttle pedal.*

Clutch Cutout: When activated, it allows faster engine acceleration and more power to the hydraulic system, without power to the drive axles, while the service brake pedal is pressed.

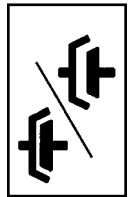

In the "OFF" position, the clutch mechanism of the transmission remains engaged when applying brakes. In the "ON" position, the clutch mechanism is disengaged while applying the brakes.

Normal brake force will hold the machine in position while accelerating the engine to power hydraulic control functions during load placement.

WARNING

Unattended machine hazard.

Activate parking brake switch and lower attachment tool to ground before leaving machine. An unattended machine can move or roll and cause death or serious injury to operator or bystanders.

Periodically check the parking brake operation to maintain adequate holding power. Always be sure the parking brake switch is off when resuming machine operation.

Parking Brake: When the machine is shut off, this switch should be depressed to actuate the parking brake mechanism in the front axle.



Middle Row Switches

Switches have graphic symbols to indicate position and response. The following mode descriptions start with the first switch on the left.

NOTE: Some switches are optional and may not be on machine.

Head Lights/Work Lights: Depressing the top of the switch will illuminate the lights mounted on the top of the operator's station and the red tail lights for forward travel operations. Depressing the bottom of the switch will illuminate the lights at the end of the boom in addition to the lights on the operator's station for additional lighting in working operations.

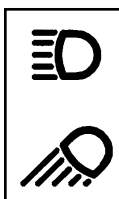

Turn Signal: This switch is used to indicate the direction of a turn with the tail lights. Depress the right arrow for a right turn; depress the left arrow for a left turn. Return the switch to the center position after the turn is completed.

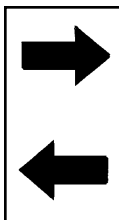

Hazard: This switch can be activated to make the tail lights flash on and off in case the machine is stalled or temporarily stopped in a traffic area on the road or jobsite.



Work Platform: This is a red switch used to activate the Work Platform Safety System. When activated, an amber lamp in the switch will light.

NOTE: This lamp will flash on and off, indicating that the WPS system is not yet fully functional, until the brakes are held on for three or more seconds.

Bottom Row Switches

Switches have graphic symbols to indicate position and response. The following mode descriptions start with the first switch on the left.

NOTE: Some switches are optional and may not be on machine.

Wiper/Washer: The windshield and top window of the operator's station are each equipped with a wiper and washer mechanism. The left switch operates the wiper and washer on the windshield; the second switch operates the wiper and washer on the top window.



Cold Starting: This switch activates the injection of an ether agent for faster engine starts in cold weather.



Heater Controls

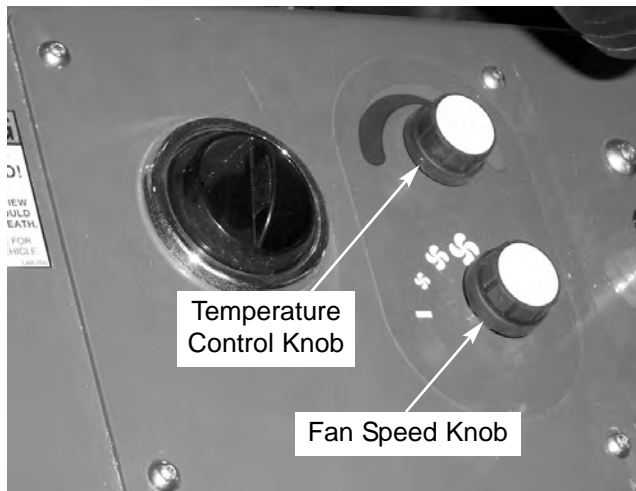

Temperature Control: The upper knob located to the left of the steering wheel. This knob is used to adjust the temperature output of the heater. Turning the knob clockwise will increase the temperature output of the cab heater.

Fan Speed: This knob is located below the temperature control knob. Rotating the knob clockwise will increase the fan speed for increased air circulation.

Travel Lever

Located on the left side of the steering wheel column, this lever is used to change travel direction (forward or reverse) and speed.

NOTE: The Travel Direction lever MUST be in N (Neutral) position before the starter will engage to start the engine.

NOTE: Backup alarm automatically sounds with travel lever in reverse.

Position “F” (FORWARD)
Position “N” (NEUTRAL)
Position “R” (REVERSE)

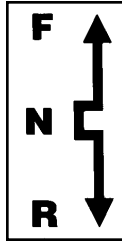

Speed Range: Twisting the lever end clockwise or counter-clockwise will change the transmission speed between low, medium and travel ranges.

Position “3” (TRAVEL RANGE)
Position “2” (MEDIUM RANGE)
Position “1” (LOW RANGE)

IMPORTANT: Care should be taken when downshifting or changing direction, because damage to the transmission can occur if shifting is forced or attempted at too high a speed. Allow engine speed to slow before any downshift or directional change is attempted.

Steering

The power steering system is designed to provide low-effort steering without shock reaction from the axle wheels to the steering wheel. Turn the steering wheel to the right or left to turn the machine in that direction.

FLOOR AND SEAT AREA

Throttle Pedal: Right-foot operated, it controls the engine RPM to match increased power requirements. Pushing down on the pedal increases engine speed; letting up on the pedal decreases engine speed.

Service Brake Pedal: Depressing this pedal activates inboard hydraulic wet-disc-type brakes on all four wheels. Separate front and rear brake systems allow bringing the machine to a safe stop if either system loses pressure.

Brake Fluid Reservoirs: Located under the hinged cover on the cab floor directly in front of the seat.

Seat Positioning: The seat is mounted on rails for forward and rearward repositioning to accommodate operator’s size. A spring-loaded latch handle under the front of the seat activates the adjustment mechanism.

Suspension Seat Option: This option is available for additional operator comfort. It is adjustable for a soft or firm ride.

RIGHT SIDE PANEL

These controls and indicators are used to position the frame, boom, attachment and outriggers. Graphic symbols on the side panel illustrate the control actions.

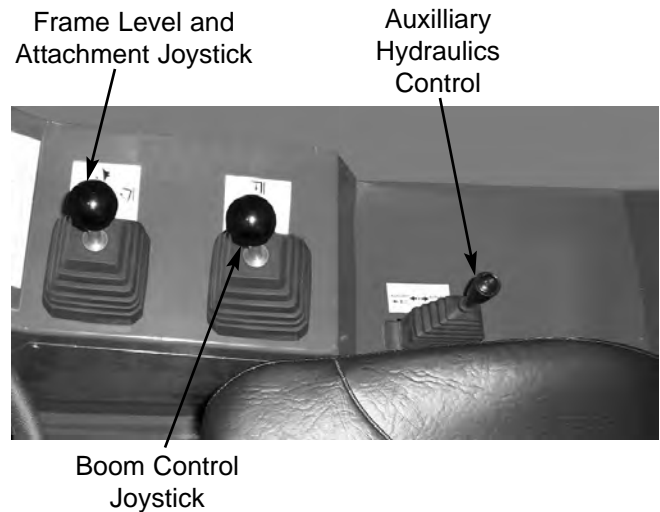

Frame Level/Attachment Tilt Joystick: The machine may be tilted slowly 10° to the left or right to level the frame and boom in relation to the ground. Move the joystick handle to the left to tilt to the left. Move the joystick handle to the right to tilt to the right.

WARNING

DO NOT level the frame with the boom raised or extended. Only level the frame while stopped and with the boom fully retracted and the attachment raised just enough to clear the ground.

To tilt the attachment tool up, move the joystick handle rearward. To tilt the attachment tool down, move the joystick handle forward.

Once the operator tilts the attachment tool to a desired angle, that angle will be maintained as the boom is raised and lowered, extended and retracted, until a new angle is set.

Boom Control Joystick: This machine has a hydraulic-type boom with telescopic sections. The sections extend by means of a hydraulic cylinder and chain system inside the boom, sequenced for uniform extension of each section.

To extend the boom, move the joystick handle to the right. To retract the boom, move the joystick handle to

the left. To raise the boom, move the joystick handle rearward. To lower the boom, move the joystick handle forward.

Auxiliary Hydraulics Control: This 2-position lever is for attachment tools that require additional hydraulics.

OPERATION INDICATORS

Frame Angle Indicator: Located in front of the operator on the ROPS upper cross tube, position of the ball shows when the frame is level relative to a sloping ground surface.



Frame Level Indicator

Boom Angle Indicator: Mounted on the left side of the outer boom, the movement of a bubble shows the angle of boom elevation relative to the ground.

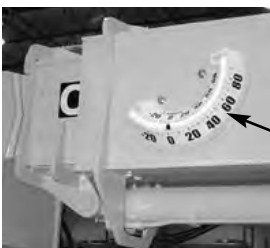

BOOM ANGLE INDICATOR

If a boom circuit hose should burst with the boom up, with or without a load, shut down the machine following the **MANDATORY SAFETY SHUTDOWN PROCEDURE** (page 8). **DO NOT** attempt repairs. Call your Mustang dealer for assistance.

The truss boom and winch attachment tools should **ONLY** be used to lift and place loads when the machine is in a stationary position. **DO NOT** use to transport loads around the jobsite. This can cause the load to swing, resulting in either load dropping or machine tipover.

NEVER use winch for lifting or moving of personnel. **NEVER** exceed the maximum rated capacity of the winch (3000 lbs./1360 kg) or exceed the load chart rating for winch applications.

DO NOT tilt the truss boom back more than 45° from horizontal. **DO NOT** attempt to use the optional rotating carriage as a load leveling function. Always level the frame prior to raising a load.

Failure to heed could result in death or serious injury.

OTHER INDICATORS

The following indicators are for checking fluid levels.

Transmission Oil Level: The dipstick is located under the access cover on the front hood section.



Transmission Dipstick

Hydraulic Fill Cap/Dipstick

Engine Oil Level: The dipstick is located on the right side of the engine.

Coolant Level: The radiator cap is located under the opening toward the rear of the main hood section.

WARNING

Use extreme caution when raising or extending the boom. The Telehandler **MUST** be level. Loaded or empty, this machine can tip if not level.

ALWAYS place the transmission in neutral, apply the parking brake and keep the service brakes fully applied before raising or extending the boom.

NEVER exceed the specified lifting and extending capacities of this machine. Serious machine damage or personal injury may result. Refer to the load charts in the operator's station or this manual.

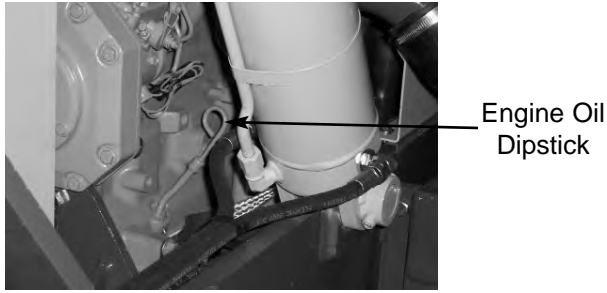

Hydraulic Reservoir Oil Level and Fill Cap: The dipstick on the fill cap of the reservoir indicates the level of the hydraulic oil in the reservoir.

SERVICE AND SAFETY FEATURES

Hydraulic Pressure Test Ports: A gauge can be attached to these ports to check main valve, joystick and steering pressures.

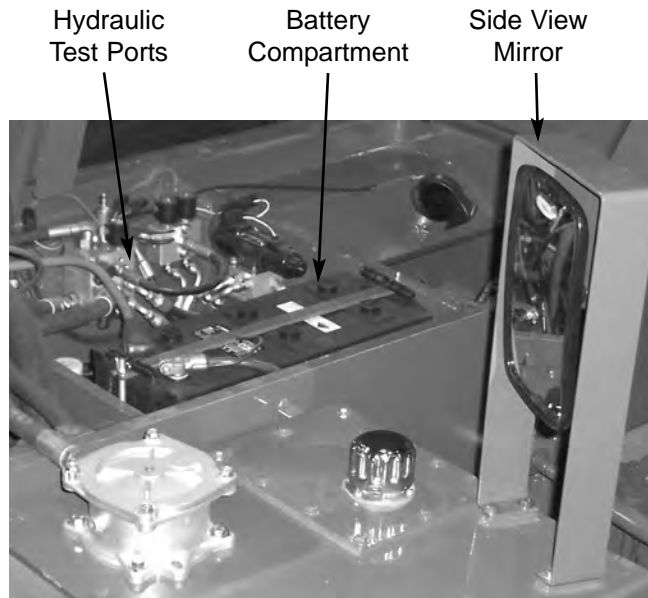

Side View Mirror: Located on the front outside corner of the fuel tank. It provides the operator with a view to the rear of the machine.

Battery Compartment: The battery is located under the access cover on the front hood section.

Backup Alarm: Located inside the rear frame cover, it produces a loud warning sound when the machine is in reverse.

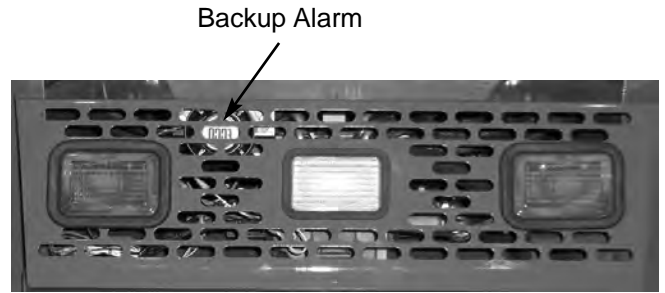

Fuse and Relay Compartment: Located under the load chart panel in the cab. Remove the four screws to gain access to the fuses and relays.

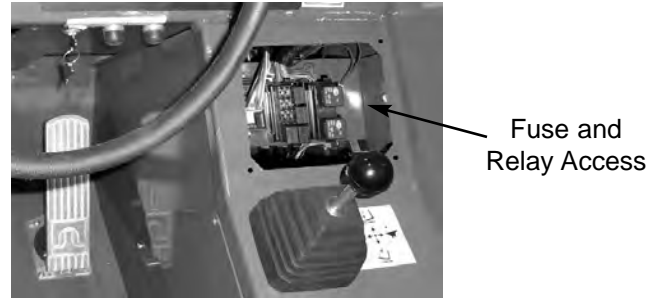

ATTACHMENT TOOLS

Mustang offers a versatile range of attachment tools to meet various lifting and material handling applications. Contact your Mustang dealer for specifications and ordering information.

ACCESSORIES

Mustang offers a range of special accessories for this machine. Contact your Mustang dealer for specifications and ordering information.

NOTE: *All accessories are field-installed unless otherwise noted. Information and parts for installing accessories will be provided by the Mustang Manufacturing Company or Mustang Telehandler dealers.*

Chapter 6

OPERATION AND ADJUSTMENTS

GENERAL INFORMATION



BEFORE starting the engine and operating the Telehandler, review and comply with ALL safety recommendations in the SAFETY chapter of this manual. Know how to STOP the machine before starting it. Also, BE SURE to fasten and properly adjust the seatbelt.

ENGINE BREAK-IN

A new engine does not require extensive “break-in.” However, for the first 100 hours of operation, follow these guidelines: Allow the engine to idle for a few minutes after every cold start. **DO NOT** idle the engine for long periods of time. **DO NOT** operate the engine at maximum power for long periods of time. Check the oil level frequently and replenish as necessary with the oil specified in the engine manual.

John Deere engines use a “break-in” oil for the first 100 hours of operation. After the first 100 hours of operation, change the oil and replace the oil filter. Consult the Lubrication chapter for the type and grade of oil to use. Refer to the Service and Storage chapter for the proper service intervals.

PRESTART INSPECTION

It is the operator’s responsibility to inspect the machine before the start of each workday. Every prestart inspection must include more than simply checking the fuel and oil levels. It is a good practice to personally inspect any machine you are assigned to use, even though it has already been put into service by other personnel.

The most efficient method of checking a machine is by conducting a “Walk-Around Inspection.”

Before mounting the operator’s compartment, walk completely around the machine to be sure no one is under, on, or close to it. Let others in the area know you are going to start up and wait until everyone is clear of the machine.

BEFORE STARTING ENGINE

Before starting the engine and running the machine, refer to the INDICATORS AND CONTROLS chapter and become familiar with the various operating controls, indicators and safety features.

STARTING THE ENGINE



ALWAYS fasten your seat belt BEFORE starting the engine. Leave the parking brake applied until the engine is running and you are ready to operate the machine.

The following procedure is recommended for starting the engine:

1. Carefully step up and grasp the hand holds to step into the operator’s compartment.
2. Adjust the seat and fasten the seatbelt.
3. Check that all controls are in their “neutral” positions, except the parking brake switch, which should be in the “ON” position.
4. Turn the key switch to “ON” position and press the start button. If the button is released before the engine starts, turn the key switch to “OFF” position, and allow the starter to stop before attempting to start again.

IMPORTANT: *Crank the starter until the engine starts. If the engine fails to start within 30 seconds, return the key to the “OFF” position, wait 2 minutes, and try again to start the engine. Cranking the engine for longer than 30 seconds will result in premature failure of the starter.*

5. After the engine starts, allow a sufficient warm-up time before attempting to operate the controls.
6. Check that indicators are in their normal operating condition.

7. Check that there are no fuel, oil or engine coolant leaks, and no abnormal noises or vibrations.

COLD STARTING PROCEDURES

A block heater or radiator lower hose heater is recommended for starting in temperatures of 20°F (-7°C) or lower. See your Mustang dealer for recommended heater.

If prevailing temperature is 40°F (4°C) or below, it may be necessary to use a cold weather starting aid to start the diesel engine. For proper use of starting aids, check instructions in the engine manual.

If the battery becomes discharged and does not have sufficient power to start the engine, jumper cables can be used for starting assistance. Refer to the jump starting instructions in the Service and Storage chapter of this manual for safe jump starting procedures.

STOPPING

The following procedure is the recommended sequence for stopping the machine:

1. Bring the machine to a stop on a level surface. Avoid parking on a slope, but if necessary park across the slope and block the wheels.
2. Fully retract the boom and lower the attachment to the ground. Idle the engine for gradual cooling.
3. Place controls in neutral. Apply the parking brake.
4. Turn the ignition switch key to the “OFF” position. Remove the key.
5. Unfasten the seatbelt, and grasp the hand holds while climbing out of the operator’s compartment.

FIRST TIME OPERATION

Make sure the engine is warm and then go through the following procedures:



Be sure the area used for test-running is clear of spectators and obstructions. Initially, operate the machine with an empty attachment tool.

Select the travel direction and the speed range. Turn off the parking brake switch and move ahead slowly, while testing the steering and brakes. Stop and operate all boom, attachment tool functions and frame leveling controls, checking for smooth response.

Apply the service brakes, stop the machine and move the direction lever to the opposite direction.

Shifting to the next higher gear may be done at any engine RPM while the machine is in motion.

DO NOT overspeed the engine when down-shifting. Allow the machine to slow down before shifting to the next lower gear.

ENGINE SHUTDOWN PROTECTION

NOTE: *Only machines that have the engine fault shutdown override switch described on page 25 and the electronic throttle pedal have this feature.*

These engines are equipped with a WARNING and SHUTDOWN feature to warn of low engine oil pressure and high engine coolant temperature. If the problem is not corrected, the engine power will be reduced automatically, or the engine will shut down.

Engine Oil Pressure

There are two low oil pressure protection features: Low Oil Pressure WARNING, and Low Oil Pressure SHUTDOWN.

At the Low Oil Pressure WARNING set-point, the warning lamp in the engine override switch will flash, and a slow engine power derate will begin. But if the oil pressure rises above the Low Oil Pressure WARNING set-point, power will slowly increase until the engine is back to full power. The lamp will continue to flash until the power has returned to normal, even if the fault condition has been corrected and the recovery is in process.

At the Low Oil Pressure SHUTDOWN set-point, the lamp in the engine override switch will light continuously, and a fast engine power derate will begin. If the oil pressure does not rise above the SHUTDOWN set-point within 30 seconds, the engine will shut down. However, if the oil pressure rises above the Low Oil Pressure SHUTDOWN set-point within 30 seconds, then the power derate speed will revert to the Low Oil Pressure WARNING speed of reaction.

Engine Coolant Temperature

There are two coolant temperature features: High Coolant Temperature WARNING, and High Coolant Temperature SHUTDOWN.

At the High Coolant Temperature WARNING set-point, the warning lamp in the engine override switch will flash, and a slow engine power derate will begin. But if the coolant temperature drops below the High Coolant Temperature WARNING set-point, the power will increase slowly until the engine is back to full power. The lamp will continue to flash until the power has returned to normal, even if the fault condition has been corrected and the recovery is in process.

At the High Coolant Temperature SHUTDOWN set-point, the lamp in the engine override switch will light continuously, and a fast engine power derate will begin. If the coolant temperature does not drop below the SHUTDOWN set-point within 30 seconds, the engine will shut down. However, if the coolant temperature drops below the High Coolant Temperature SHUTDOWN set-point within 30 seconds, then the power derate speed will revert to the High Coolant Temperature WARNING speed of reaction.

PARKING BRAKE

NOTE: *The parking brake mechanism within the front axle is not designed for, and not intended to be used as, the primary means of stopping movement of the machine. Hydraulic braking provided through the service brakes within the axles is the primary means for stopping movement. The axle-by-axle split brake system is the secondary means of stopping movement.*

The proper sequence for correct machine operation is to always engage the parking brake switch before shutting off the engine; and to disengage the parking brake ONLY after the engine is running. In an emergency however, if it becomes necessary to STOP movement, activate the parking brake switch to “ON.”

CHANGING ATTACHMENT TOOLS

The Telehandler boom nose will accept Quick-attach System Mustang attachment tools. The Quick-attach System has a quick-release hookup and locking mechanism for mounting framing-type or masonry-type attachment tools to the boom nose.

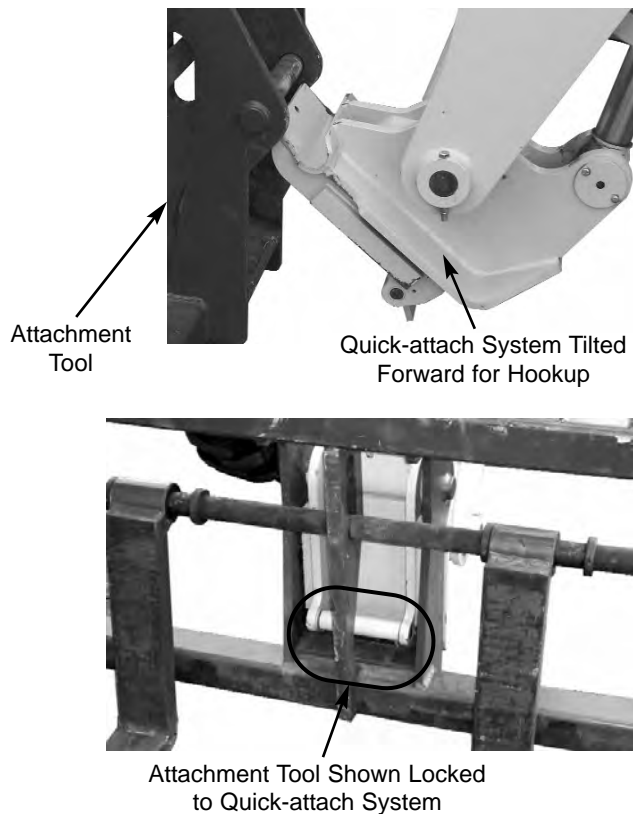

Quick-attach System Attaching Detail

Attaching

To pick up the attachment tool proceed as follows:

1. Raise the boom slightly and extend it 2 to 3 feet (600 to 900 mm) for better visibility and tilt the Quick-attach System forward.
2. Align the Quick-attach System squarely with the back of the attachment tool.
3. Slowly extend the Quick-attach System and lower the hooks under the attachment tool hookup bar.
4. Tilt the Quick-attach System back so that the lock plate engages the attachment tool. This secures the attachment tool to the quick-attach system.
5. For an attachment tool with auxiliary hydraulics, connect hoses to the quick-disconnect connectors on the boom nose.

Detaching

To detach attachment tool, proceed as follows:

1. Raise the boom slightly and extend it 2 to 3 feet (600 to 900 mm) for better visibility. Lower the boom until the attachment tool is approximately 12” (0.3 m) off the ground.

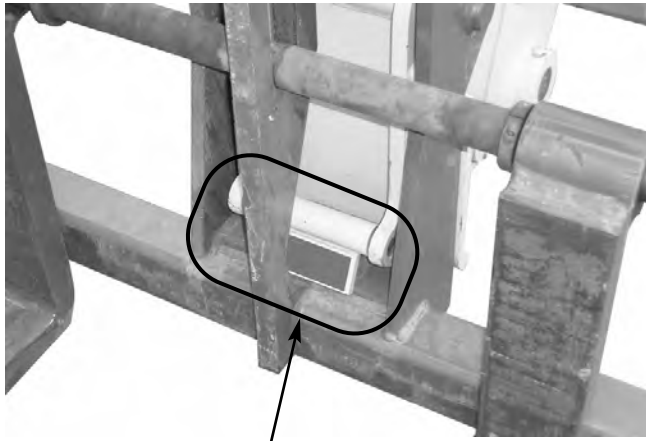

Attachment Tool Shown
Unlocked for Release from
Quick-attach System

Quick-attach System Detaching Detail

2. Roll the carrier rearward as far as it will go. Once the carrier is rolled all the way back, perform the MANDATORY SAFETY SHUTDOWN PROCEDURE (page 8, Safety chapter).
3. With the engine off, leave the operator's station. Manually raise the lock spring and flip the lock plate up and outward at least 180° so it is in position to re-lock on the next attachment tool.
4. Tilt the Quick-attach System forward to allow the attachment tool to roll out, then lower the boom so the hook ears clear the hookup bar on the attachment tool.

NOTE: *One side of the lock plate has a bright red decal to indicate the unlocked position.*

5. If the attachment tool has auxiliary hydraulics, disconnect the hoses from the quick-disconnects on the boom nose.
6. Start the engine and tilt the Quick-attach System forward, then slowly back the machine until the attachment tool is free from the boom nose.

WARNING

Modifications, alterations to, or use of attachment tools NOT authorized by Mustang (or the manufacturer) in writing can void warranty and cause machine damage and/or serious personal injury or death.

SELF-LEVELING

The machine is equipped with a hydraulic self-leveling feature. This feature is designed to keep the attachment tool level while the boom is being raised.

GENERAL MACHINE OPERATION

WARNING

Exhaust fumes can kill. Ensure proper ventilation when starting indoors or in enclosed areas.

Use proper hand holds, NOT the steering wheel or control levers when mounting and dismounting.

NEVER operate the machine with safety guards or covers removed.

Over-inflated tires can explode and cause injury or death. Tire repairs MUST be made only by authorized personnel using proper tools and equipment.

Check the Telehandler to be sure all systems are in good operating condition. Perform the following steps before starting the machine for the first time each day:

1. Check the engine oil and coolant, transmission oil and hydraulic oil levels.
2. Be sure weekly lubrication has been done.
3. Visually inspect for leaks, broken or malfunctioning parts. Be sure all caps, covers and safety shields are in place.
4. Check tires for cuts, bulges, nails, correct pressure, loose wheel nuts, etc.
5. Inspect the work area. Be sure you know where you will make load pickups, lifts, and turns. Look over the terrain of the jobsite for holes, obstacles, slippery surfaces, soft or deep mud.
6. Check clearances of ramps, doorways and passage-ways. Check overhead clearances if you will travel and place loads near power or telephone lines.

If the machine is found to be in need of repair or in any way unsafe, or contributes to an unsafe condition, the matter shall be reported immediately to the user's designated authority. The machine must NOT be operated

until it has been restored to a safe operating condition.

Operate the travel controls gradually and smoothly when starting, stopping, turning and reversing direction.

Grade and Slope Precautions

The Telehandler complies with industry stability test requirements and is stable when properly operated. However, improper operation, faulty maintenance, and poor housekeeping can contribute to a condition of instability and defeat the purpose of the standard.

The amount of forward and rearward tilt to be used is governed by the application. Although use of maximum rearward tilt is allowable under certain conditions, such as traveling with the load fully lowered, the stability of the machine, as determined by the industry standard tests, does not encompass consideration for excessive tilt at high elevations, or the handling of off-center loads.

Handle only loads within the capacity limits of the machine, and which are stable and safely arranged. When attachments are used, extra care should be taken in securing, manipulating, positioning and transporting the load.

Grade Limits

NOTE: *Grade limits are based on ANSI/ITSDF standard B56.6-2005.*

This Telehandler meets or exceeds the safety standard (ANSI/ITSDF B56.6) stability limits for rough terrain forklifts. The stability tipping limits cover specific, controlled test conditions, which are extremes, and which are not intended to be achieved during normal worksite operations. The following specifications are provided only as information to the operator, and must not be used as a guideline for operating the telehandler. For safe operation, always follow the instructions and warnings provided in this manual.

1. DO NOT place or retrieve loads on an up or down slope or grade that exceeds 7% or 4°.
2. DO NOT travel up or down a grade or slope that exceeds 22% or 12° while loaded.
3. DO NOT place or retrieve loads on a side hill with a slope or grade that exceeds 12% or 7°. Regardless of the terrain or position of the wheels, the **FRAME MUST BE LEVEL**, as indicated by

the frame angle indicator on the ROPS/FOPS crossmember.

4. DO NOT travel across a side hill that exceeds 18% or 10° grade. Regardless of the terrain or position of the wheels, the **FRAME MUST BE LEVEL**, as indicated by the level indicator on the ROPS/FOPS cross member. The attachment tool **MUST** be maintained at the “carry” position with the boom fully retracted, and attachment tool at minimum ground clearance.

When ascending or descending grades in excess of 5% or 3°, the machine should be driven with the load upgrade. An unloaded machine should be operated on all forward grades with the load handling attachment tool downgrade, tilted back if applicable, and raised only as far as necessary to clear the road surface. Avoid turning if possible and use extreme caution on grades, ramps and inclines. Normally travel straight up and down the slope.



WARNING

DO NOT level the frame with the boom raised or extended. Level the frame ONLY while stopped, with the boom fully retracted and the attachment tool raised just enough to clear the ground.

Traffic Flow Patterns

Know and understand the traffic flow patterns of your jobsite. Know all Telehandler hand signals for safety. Utilize signal persons and be sure you can see the signal person and acknowledge the signals given.

When ramps must be used in transporting loads with the machine, the following are the minimum widths for safe travel:

Compacted dirt, gravel, etc.	12 ft. (3.6 m)
Woodboard, concrete, etc.	10 ft. (3.0 m)

Permanent aisles, roadways and passageways, floors and ramps must be clearly defined or marked. Permanent or temporary protrusion of loads, equipment, material and construction facilities into the usual operating area must be guarded, clearly and distinctively marked, or clearly visible.

Maintain a safe distance from the edge of ramps, platforms and other similar working surfaces.

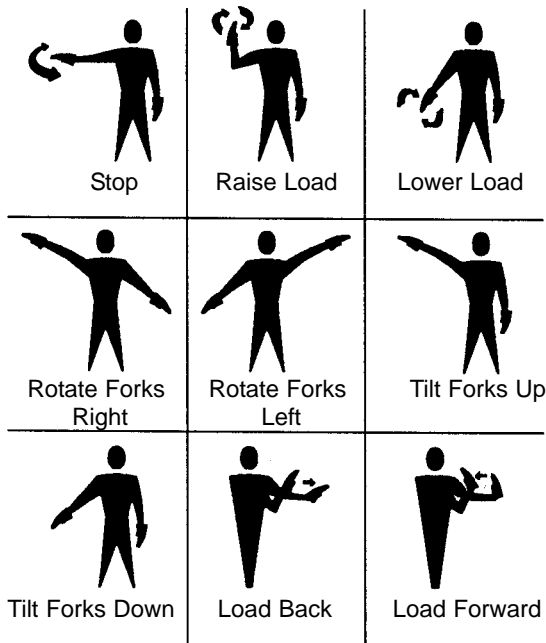

Safety Hand Signals

Controlled lighting of adequate intensity should be provided in operating areas. Where operating conditions indicate, the operator/user is responsible for having the machine equipped with lights.

Provisions must be made to prevent trucks, semi-trailers and railroad cars from being moved during loading and unloading.

Wheel stops, parking brakes, or other positive holding means must be used to prevent movement during loading and unloading.

DO NOT move railroad cars and trailers with the Telehandler.

DO NOT use the boom and attachment for leverage to push the machine out of mud.

IMPORTANT: *DO NOT lower boom at high engine speed when attachment tool is at maximum rearward tilt. Damage to slave cylinders may result.*

GENERAL LOAD HANDLING

NEVER attempt to work controls except from the operator's seat. NEVER jerk or use fast movements. Avoid sudden stops, starts and changes in direction.

Operation of the hydraulic system depends on engine speed and the distance the controls are moved. When operating these controls it is important to develop a technique called "feathering." Feathering the control means you start the desired motion by moving the control a small amount away from neutral. Then after movement has started, the control can be eased to full movement. Use the same feathering technique to stop the motion.

WARNING

Excessive speed can be hazardous. **ALWAYS** exercise caution and good judgement while operating the machine.

Twice daily, increase the engine speed (to fast idle) and extend and retract the frame leveling cylinder to the stroke limit. This removes any air trapped in the circuit, which could cause the machine to lean to one side or the other.

ALWAYS maintain a safe distance from electric power lines and avoid contact with any electrically charged conductor and gas line. It is not necessary to make direct contact with a power line for power to ground through the structure of the machine. Keep the boom at least 10 ft. (3 m) from all power lines. Accidental contact or rupture can result in electrocution or an explosion. Contact the North American One-Call Referral System at (888) 258-0808 for the local "Digger's Hotline" number or proper local authorities for utility line locations **BEFORE** starting to dig!

Keep all body parts inside the operator's station while operating the machine. **BE SURE** of clearance for the attachment tool when turning, working around buildings, etc.

Turning corners too fast can tip the machine, or cause a load to tip off the attachment. Sudden slowing or stopping of the machine may cause the load to drop off the attachment tool.

Be certain you can control both speed and direction before moving. Always place the machine in neutral and set the parking brake before raising or extending the boom. **NEVER** drive the machine up to someone standing in front of the load.

NEVER leave the operator's station without first lowering the attachment tool to the ground. Then set the parking brake, place controls in neutral, shut off engine and remove the key. **AVOID** parking the machine on a slope, but if necessary, park across the slope and block the tires.

The following example illustrates proper use of the load zone charts for the Telehandler:

Example:

The operator, using a standard carriage attachment tool, wants to raise a 2000 lb. load 20 feet high, and can only get to within 15 feet of the load placement point. Can it be done within the capacity of the machine?

Analysis: See "Typical Load Zone Chart" below.

Load Capacity and Reach

This machine has flip-charts in the operator's station that provide, at a glance, the load capacity limits at various positions of attachment tool extension and elevation. A set of the load zone charts is reproduced at the end of this manual for reference.

Projecting up from the 15-foot mark on the horizontal axis to intersect a line through the 20-foot mark on the vertical axis shows the load can be placed in the 2000 lb. zone.

A typical load zone chart is shown on this page. The scale on the left indicates height in feet above the ground level. The scale on the bottom shows the distance in feet out from the front of the machine. The arc lines noted by the numbers "1" through "5" correspond with the position extension markers on the operator side of the intermediate boom section.

During placement, the operator observes when the extension reference number "3" on the boom is visible and stops. The maximum safe distance of extension with this load has been reached.

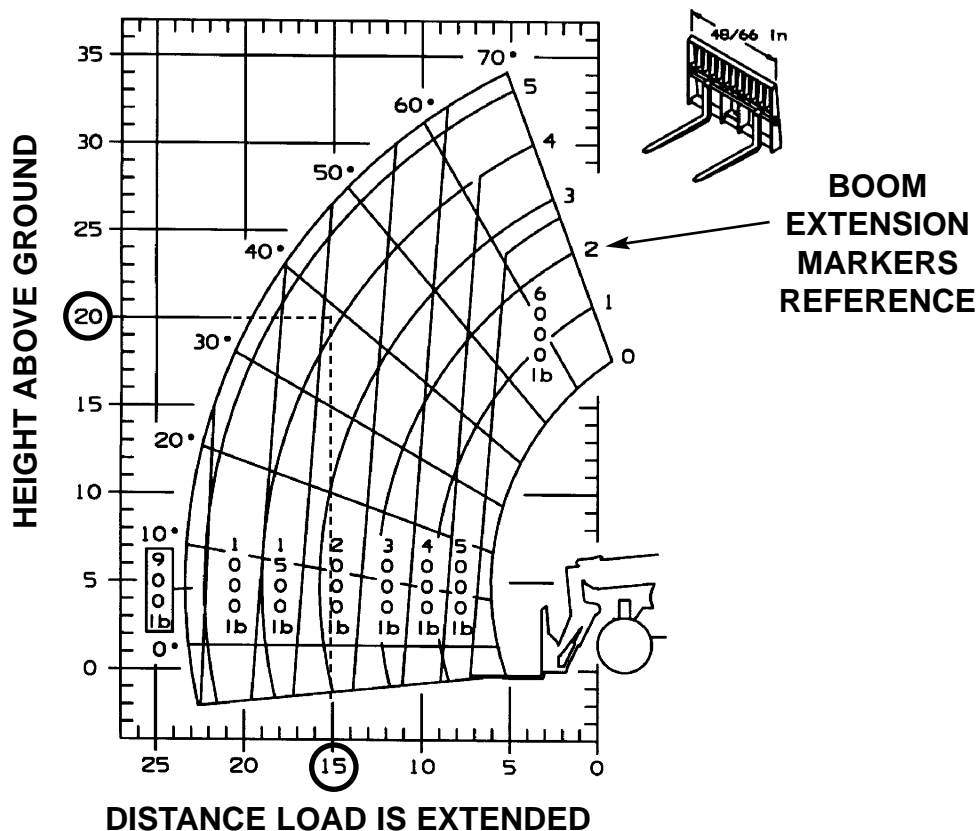

Typical Load Zone Chart

 **WARNING**

NEVER exceed the rated operating capacity of the Telehandler as shown on the load zone charts.

LIFTING ATTACHMENT TOOL APPLICATIONS

Picking Up the Load

Inspect the load. If it appears unstable, **DO NOT** attempt to move it. **DO NOT** attempt lifting double-tiered loads, or straddling side-by-side pallets with one on each fork. **NEVER** add extra unauthorized counterweights to this machine.

 **WARNING**

Operating conditions can reduce the machine's safe operating capacity. Exceeding the capacity when raising or extending the boom will cause the machine to tip forward.

Approach the load squarely and slowly with the machine straight and level. Adjust the space between forks, if necessary. Engage the load equally on both forks until the load touches the carriage backrest. Tilt the forks back to position the load for travel.

Carrying the Load

If the load obstructs your view, get someone to direct you. Maintain ground speeds consistent with ground conditions and that permit stopping in a safe manner.

 **WARNING**

NEVER travel with the boom above the carry position (attachment tool should be at minimum ground clearance). Boom should be fully retracted.

Use lower gear when traveling down an incline. NEVER coast with the transmission in neutral. Travel up and down grades slowly.

DO NOT operate the machine on a slope or grade that exceeds 22% or 12°.

Load Elevation and Placement

For ground level load placement, be sure the area under the load and around the machine is clear of equipment and personnel. Lower the load to the ground, tilt the forks to the horizontal position, and then carefully back away to disengage the forks from the load.

For elevated or overhead placement, bring the machine as close as possible to the landing point, and then:

1. Level the machine **BEFORE** raising the load. Use extreme caution for high placement. Be sure personnel are clear of the area where the load or the machine could tip or fall.
2. Set the parking brake, hold the service brake pedal in fully applied position and slowly raise the load, maintaining a slight rearward tilt to cradle the load.
3. As the load approaches the desired height, feather the boom control at minimum speed until the load is slightly higher than the landing point.
4. Continue the feathering technique and lower the load into place.
5. Free the forks from the load by alternately retracting and raising the boom. If this process is not possible, very slowly and carefully reverse the telehandler to free the forks from the load.
6. Lower the forks to travel height.

Installation of the Work Platform (WP)

 **WARNING**

The machine must not be used to lift or carry personnel, or be fitted with any form of Work Platform unless fitted with the optional WPS System.

If fitted with the WPS System, the Mandatory Work Platform Safety Rules (p. 12) must be followed at all times while lifting personnel.

1. Center the forks on the carriage, spaced apart to match the distance required to engage the WP.
2. After the forks are fully engaged in the WP, secure the WP to the forks. This can be accomplished by means of a retaining pin behind the heel of the forks as shown on the next page.

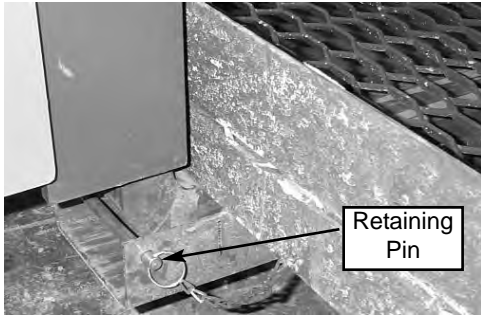

- Secure the forks from pivoting upward in case the WP is lowered onto an obstruction. This can be accomplished by using the chain supplied with WP, to secure the lower portion of the WP to the bottom of the carriage, as shown.

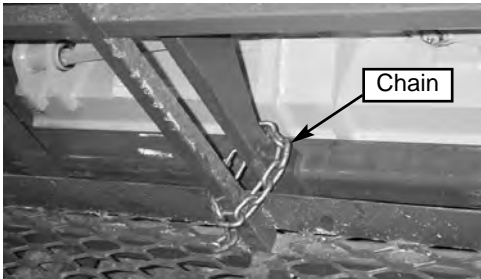

- Secure the lanyard from the body harness to the WP or the boom. Each person in the WP should have a body harness with a lanyard attached to the WP.

Elevating Personnel

This Telehandler is primarily intended for use as a material handler. It should only be used to elevate personnel if it is equipped with the (optional) WPS System when there is no other practical option. If this machine is to be used to elevate personnel, then use only an approved work platform, lift personnel only with the (optional) WPS System activated, and follow the "Mandatory Work Platform Safety Rules" (*p. 12 Safety chapter*).

If this Telehandler is equipped with a WPS System, and is to be used for elevating personnel, the system must be activated, by the "WPS System" mode switch, which is located in the instrument and switch panel. To activate the system, apply and hold the service brakes on for three or more seconds, and press the top of the WPS rocker switch. The system is activated when the lamp in the WPS System rocker switch is on continuously.

WARNING

The WP must meet ANSI/ITSDF B56.6-2005, Section 8.24. (See page 14 in the Safety chapter for WP design requirements.) If the WP being used does not offer means to secure the WP to the forks and to secure the forks from pivoting, as shown in Steps 2 and 3, then an alternate method must be used.

- Connect the coiled wire from the remote shutdown switch to the connector on the end of the boom. Secure the remote shutdown switch to the WP using the strap attached to the switch as shown below.

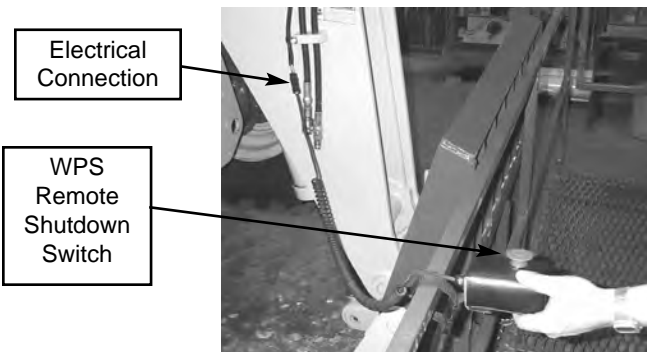

Remote Shutdown Switch with Coiled Wire Connector

WARNING

ALWAYS check the WPS System for proper operation prior to use. (See WPS System checking procedure.)

When the WPS System is active:

- transmission is de-clutched into Neutral,
- parking brake is applied,
- auxiliary hydraulic and carriage tilt and swing functions are disabled,
- machine inclination sensor is activated, with the result that the Telehandler must be level laterally (side-to-side) and longitudinally (front-to-back) to the factory pre-set limits before the boom control joystick will function, and
- remote shutdown switch is activated, meaning that the switch must be connected and in the "on" position for the boom control joystick to function. Pressing the switch will disengage the boom control joystick, and stop all platform movement. The remote shutdown switch box is supplied with a coiled electrical cable that must be connected to the outlet on the front of the innermost boom section near the carriage. The switch must be accessi-

ble by the platform personnel at all times the platform is to be moved.

To de-activate the WPS System, apply and hold the service brakes on for three or more seconds, and press the bottom of the WPS System rocker switch. The system is de-activated when the lamp in the WPS System rocker switch is off.

NOTE: *If the lamp in the WPS system rocker switch is flashing, apply the service brakes until the lamp goes off.*

 **WARNING**

In an emergency, if the platform worker has activated the remote shut-off switch and then is not able to re-activate the switch, such as if the worker fainted, then the Telehandler operator is permitted to turn off the WPS System to regain control of the boom functions, in order to lower the work platform and come to the aid of the worker. But, understand this is only permitted in case of an emergency. Otherwise, the WPS System must be used at all times when there are workers on the platform. This is the only exception!

 **WARNING**

NEVER use frame leveling to position an elevated load. Always lower the load to the ground and reposition the machine.

If a hydraulic boom circuit hose bursts with the boom up, shut down the machine. **DO NOT** attempt to lower the boom or make repairs. Call your Mustang dealer.

As lift height increases, depth perception decreases. High elevation placements may require a signal person to guide the operator. The machine becomes less stable as the load is raised higher.

DO NOT ram the lift cylinders to the end of the stroke. The resulting jolt could spill the load.

The truss boom attachment tool should ONLY be used to lift and place loads when the machine is in a stationary position. DO NOT use to transport loads around the jobsite. This can cause the load to swing, resulting in either the load dropping or the machine tipping over.

SUSPENDED LOADS

The handling of suspended loads by means of the truss boom or other similar device can introduce dynamic forces affecting the stability of the machine that are not considered in the stability criteria of industry test standards. Grades, sudden starts, stops and turns can cause the load to swing and create a hazard.

DO NOT exceed the Telehandler capacity for handling suspended loads. Only lift the load vertically; NEVER drag it horizontally. Use tag lines to restrain load swing whenever possible.

Guidelines for Free Rigging / Suspended Loads

1. The rigging equipment must be in good condition and comply with the applicable U.S. OSHA regulation, 1910.184, "Slings," or 1926.251, "Rigging equipment for material handling."
2. The rigging equipment must be secured to the forks such that it cannot slip or slide either sideways or fore and aft.
3. The capacity of the fork(s) and the machine (whichever is less) must not be exceeded.
4. The load center must remain at 24" (610 mm) or less.
5. No lifting of material may be done when anyone is on the load, rigging or forks.
6. Multiple pickup points on the load are preferred to prevent the load from rotating, but a single pickup point may be used if one or more tag lines are utilized. And, of course, the load must never be positioned over personnel at any time.

ROAD TRAVEL

For short distance highway travel, attach a Slow-Moving Vehicle (SMV) emblem (purchased locally) to the rear of the Telehandler. For highway operation, obtain and install an amber flashing beacon.

NOTE: ALWAYS follow ALL state and local regulations regarding the operation of equipment on or across public highways. Whenever there is an appreciable distance between jobsites, or if driving on public highway is prohibited, transport the machine using a vehicle of appropriate size and capacity.

TRANSPORTING BETWEEN JOBSITES

ALWAYS abide by the following recommended procedures and guidelines when using ramps to load the machine onto (and unload it from) a truck or trailer. Failure to heed can result in damage to equipment and serious personal injury or death!

Tie-down hooks are provided for inserting chains through to secure the machine while transporting.



Front Tie Down



Rear Tie Down

Loading Machine Using Ramps

NOTE: A matched pair of ramps is required.

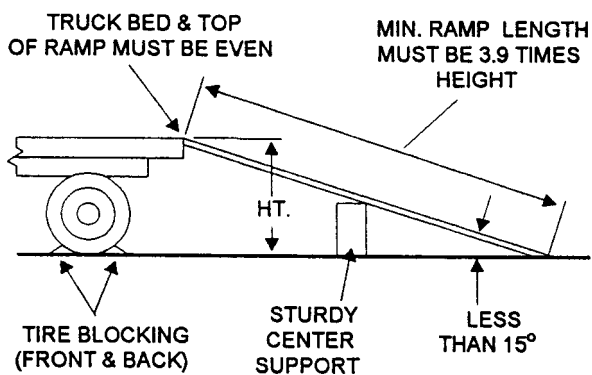

Ramp Placement

1. The ramps MUST be of sufficient strength to support the machine. The use of strong steel ramps is recommended, as well as center supporting blocks.
2. The ramps MUST be firmly attached to the truck or trailer bed with NO step between the bed and the ramps.

3. The incline of the ramps MUST be less than 15 degrees. Ramp length MUST be at least 16 feet (4.9 m) long.
4. Ramp width MUST be at least 1-1/2 times the tire width.
5. Block the front and rear of the tires on the truck or trailer. Engage the parking brake.
6. Position the machine with the boom facing toward the front of the truck or trailer so that it is straight in line with the ramps.
7. Slowly (at the lowest engine speed possible) and carefully drive the machine up the ramps.
8. Secure the machine to the bed of the truck or trailer.

WARNING

NEVER adjust travel direction (even slightly) while on the ramps. Instead, back off the ramps, and then realign the machine with the ramps.

WARNING

NEVER transport the machine with the boom raised or extended. **BE SURE** to secure the machine (including boom) to the truck or trailer bed using chain and binders or steel cables, to prevent any movement while transporting.

Unloading Machine Using Ramps

NOTE: A matched pair of ramps is required.

Repeat Steps 1 through 5 and proceed as follows to unload the machine:

6. Remove the tie-down chains/cables.
7. If necessary, adjust the machine so that the wheels are in line and centered with the ramps.
8. Slowly (at the lowest engine speed possible) and carefully drive the machine down the ramps.

THEFT DETERRENTS

Mustang has recorded all component part numbers and serial numbers. Users should take as many of the following actions as possible to discourage theft, to aid in the recovery in the event the machine is stolen, and to reduce vandalism:

1. Remove keys from unattended machines.
2. Attach, secure, and lock all anti-vandalism and anti-theft devices on the machine.
3. Lock doors of cabs when not in use.
4. Inspect the gates and fences of the equipment storage yard. If possible, keep machines in well-lighted areas. Ask the local law enforcement agency to make frequent checks around the storage and work sites, especially at night, during weekends, and on holidays.
5. Report any theft to your dealer and insurance company. Provide the model and all serial numbers. Request your dealer to forward this information to Mustang Manufacturing Company.

INTENTIONALLY BLANK

Chapter 7

LUBRICATION

GENERAL INFORMATION

WARNING







NEVER lubricate or service this unit when any part of the machine is in motion. **ALWAYS** exercise the **MANDATORY SAFETY SHUT-DOWN PROCEDURE** (p.8, **SAFETY** chapter) before lubricating or servicing this equipment.

NOTE: The **MAINTENANCE** chapter in this manual has provisions for recording the dates and hourmeter readings after lubrication or other service has been performed; use those spaces to keep a log for maintaining a current service interval record. Proper routine lubrication is an important factor in preventing excessive part wear and early failure.

LUBRICANTS

The chart on this page lists the locations, temperature ranges and recommended types of lubricants to be used when servicing this machine. Also refer to the separate engine manual for additional information regarding recommended engine lubricants, quantities required and grades.

NOTE: Refer to "Operator Services" in the **SERVICE AND STORAGE** chapter of this manual for detailed information regarding periodic checking and replenishing of lubricants.

Hydraulic System Reservoir 								
Use Mobil DTE 15M, or an equivalent that contains anti-rust, anti-foam and anti-oxidation additives and conforms to ISO VG46. Capacity: 35 Gallons (133 liters)								
All Grease Fittings 								
Use No. 2 Lithium-based Grease								
Engine Crankcase Oil 								
<table><thead><tr><th>Ambient Temperature</th><th>Grade*</th></tr></thead><tbody><tr><td>-22°F - 86°F (-30°C - 30°C)</td><td>SAE 5W-30</td></tr><tr><td>-4°F - 104°F (-20°C - 40°C)</td><td>SAE 10W-40</td></tr><tr><td>5°F - 122°F (-15°C - 50°C)</td><td>SAE 15W-40</td></tr></tbody></table> <p>*API Service Classification: CH-4/CI-4 *API Service Classification for first 100 hours on new or rebuilt John Deere engines: CC or CD Capacity: 14 Quarts (13.3 liters)</p>	Ambient Temperature	Grade*	-22°F - 86°F (-30°C - 30°C)	SAE 5W-30	-4°F - 104°F (-20°C - 40°C)	SAE 10W-40	5°F - 122°F (-15°C - 50°C)	SAE 15W-40
Ambient Temperature	Grade*							
-22°F - 86°F (-30°C - 30°C)	SAE 5W-30							
-4°F - 104°F (-20°C - 40°C)	SAE 10W-40							
5°F - 122°F (-15°C - 50°C)	SAE 15W-40							
Axle Gear Oil 								
MobilFluid® 422/423 (recommended) Super Tractor Oil Universal API GL5 80W90 or equivalent Differential Capacity: 9.6 quarts (9.0 liters) Planetary Capacity (each side): 0.6 quarts (0.5 liters)								
Transmission Oil 								
Use Sunco Multi-ATF or equivalent Capacity: 24 quarts (23.0 liters)								
Brake System 								
Use Sunco Multi-ATF or equivalent								

REPLACEMENT FILTER CHART

ENGINE TYPE	AIR FILTER	FUEL FILTER	ENGINE OIL	HYDRAULIC		TRANS. OIL
				FILTER	STRAINER	
JOHN DEERE w/ Mechanical Throttle	Primary 137498	L98978	102173	L97489	L49327	L99184
	Safety 137501					
JOHN DEERE w/ Electronic Throttle	Primary 137498	102174	102173	L97489	L49327	L99184
	Safety 137501					

GREASING

Refer to the illustrations and listings for fitting locations. Wipe dirt from the fittings before greasing them to prevent contamination. Replace any missing or damaged fittings. To minimize dirt build-up, avoid excessive greasing.

BASIC MACHINE GREASE FITTING LOCATIONS

Every 50 Hours (or weekly)

Refer to the illustration on the facing page for locations.

CHASSIS AREA

- 1 Brake foot pedal linkage1
- 2 Wheel spindle pins (per axle)4
- 3 Axle to frame pivot pins (per axle)1
- 4 Drive shaft, slip joint (per shaft)1
- 5 Drive shaft, U-Joint (per shaft)2
- 6 Level cylinder pivot pins2
- 7 Base end lift cylinder pivot pins2
- 8 Base end slave cylinder pivot pins2

BOOM AREA

- 9 Boom to frame upright pivot pins2
- 10 Rod end slave cylinder pivots pins2
- 11 Rod end lift cylinder pins2
- 12 Extend cylinder pivot pins2
- 13 Chain sheave pins2
- 14 Quickattach to boom nose pivot pins2
- 15 Tilt cylinder pivot pins2
- 16 Rotate cylinder pivot pins2
- 17 Rotate carriage wear pads3
- 18 Rotate pivot bearing1
- 19 Boom slide pads - as required, front and rear

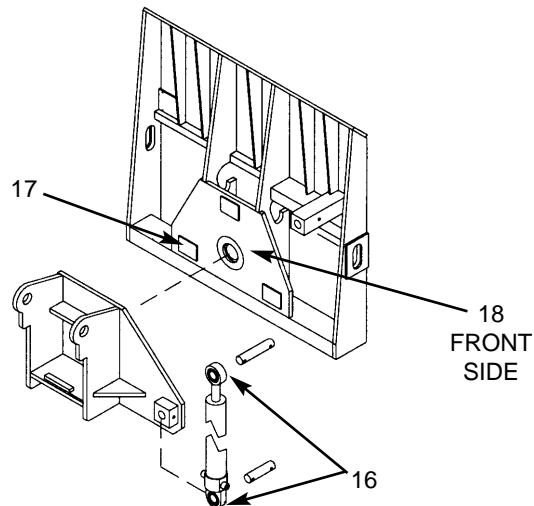

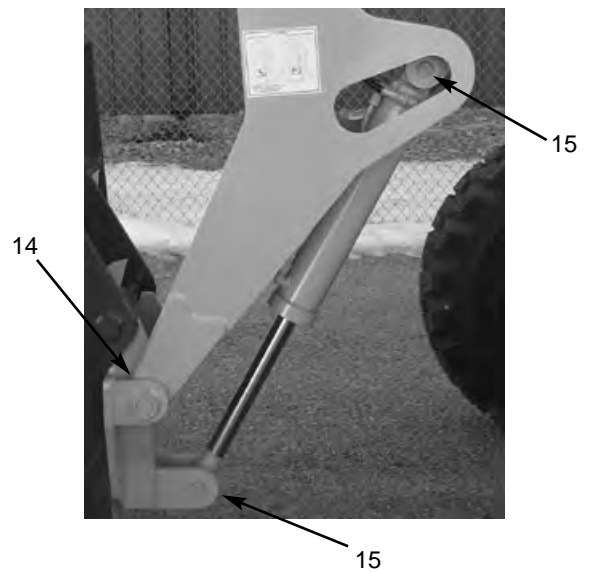
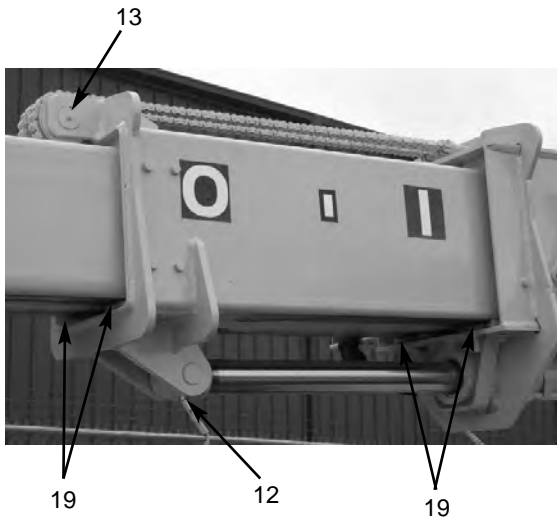
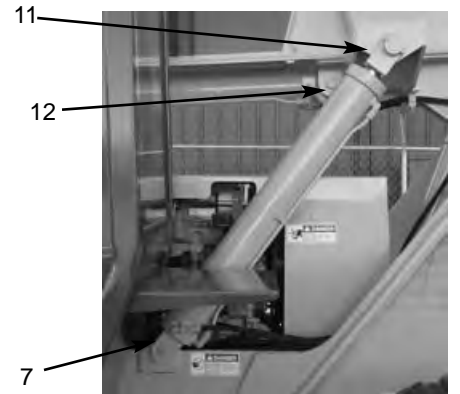
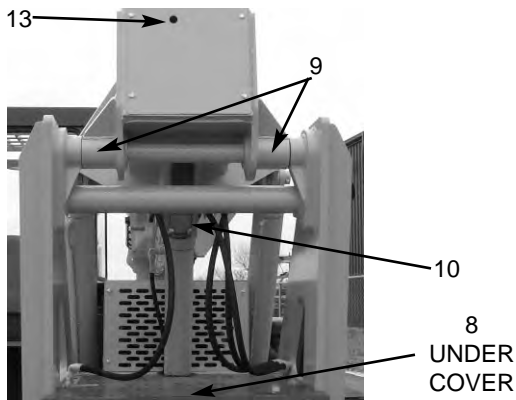
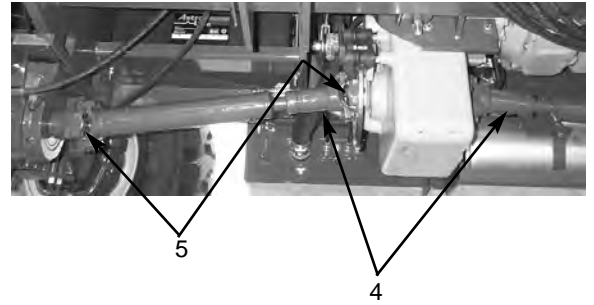
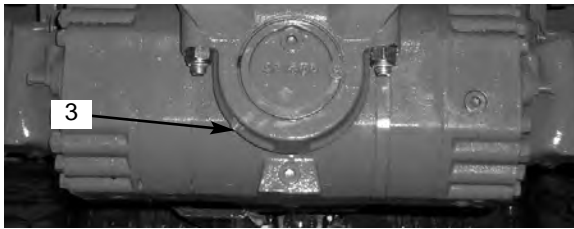
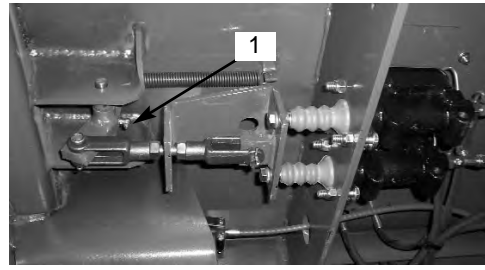
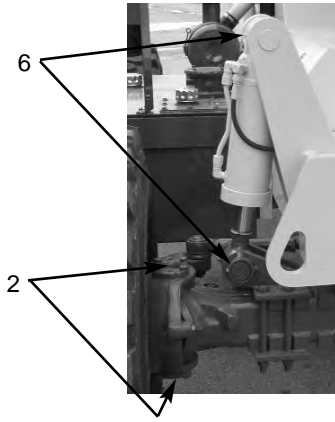

Grease Fittings Locations

Chapter 8

SERVICE AND STORAGE

GENERAL INFORMATION

WARNING

BEFORE performing any service on the Telehandler, unless expressly instructed to the contrary, exercise the **MANDATORY SAFETY SHUTDOWN PROCEDURE** (p. 8 Safety chapter). After service has been performed, **BE SURE** to restore all guards, shields and covers to their original positions **BEFORE** resuming machine operation.

NOTE: All service routines, with the exception of those described under the “Dealer Services” topic, are owner-operator responsibilities. All operator services described under the subtopics are also referred to on a decal located on the inside right side panel of the operator’s station. Refer to the **LUBRICATION** chapter of this manual for lubrication information.

NOTE: This **SERVICE AND STORAGE** chapter describes procedures to follow for making routine maintenance checks, adjustments and replacements. Most of the procedures are also referred to in the **MAINTENANCE** chapter of this manual. For engine related adjustments and servicing procedures, refer to the engine manual provided.

PRECAUTIONS

DO NOT perform any maintenance or repair without the owner’s prior authorization. Allow only trained personnel to service the machine.

Warranty repairs can only be done by an authorized Mustang dealer. Dealers know what portions of the machine are covered under the terms of the Mustang Warranty and what portions are covered by other vendor warranties.

When a problem occurs, do not overlook simple causes such as an empty fuel tank. Check for leaks and broken connections. Make note of any specific symptoms, noises, etc. and contact your local Mustang dealer.

IMPORTANT: Always dispose of waste lubricating oils, anti-freeze and hydraulic fluids according to local regulations or take them to a recycling center for disposal. **DO NOT** pour them onto the ground or into a drain.

DEALER SERVICES

The following areas of internal components service replacement and operating adjustments should only be by (or under the direction of) an authorized Mustang Telehandler dealer.

IMPORTANT: **DO NOT** service or repair major components, unless authorized to do so by your Mustang dealer. Any unauthorized repair will void the warranty.

POWER TRAIN COMPONENTS

The engine and transmission are coupled directly to each other. All service routines related to the internal components are precise and critical to proper power train operation. The axle differential and planetary ends are also sophisticated assemblies that require special know-how and tools for servicing.

IMPORTANT: If any power train components are suspected of faulty operation, contact your Mustang dealer for assistance.

HYDRAULIC SYSTEM COMPONENTS

Valves, pumps, motors and cylinders are also sophisticated assemblies which require special know-how and tools for servicing. All cylinders are appropriately designed with particular strokes, diameters, checks and hose connection provisions unique to the machine application requirements. A schematic (**MAINTENANCE** chapter) can be used as a guide for service reference, as required.



WARNING

Tilt, lift, extend and leveling cylinders have counterbalance valves. These valves keep hydraulic fluid from entering and exiting the cylinders while they are not being activated, and they are under extremely high pressure. Before removing one of these valves, you ARE REQUIRED to call your Mustang dealer or Mustang Manufacturing Company Service Department. Failure to do so may result in serious injury or death.

Internal service on any of these components should only be performed by (or under the direction of) an authorized Mustang Telehandler dealer.

ELECTRICAL COMPONENTS

An electrical system schematic is provided, which includes instrumentation, electrical components and switch connections. It is located at the back of this manual and can be used as a guide for service reference, as required.

OPERATOR SERVICES

Some of the operator-related services will require access to components located inside the superstructure, under shields, hoods and covers. The chart on this page notes the components accessed in each particular area.

ACCESS TO COMPONENTS CHART

Component	Operator's Station	Frame	Front Cover	Mid-Rear Hood
Axle (underside)		●		
Engine				●
Transmission (center area)			●	
Drive Shafts (underside)		●		
Main Control Valve (rear)		●		
Muffler (underside)		●		
Air Cleaner (top fuel tank)		●		
Battery		●		
Radiator				●
Brake Valve (underside)	●			
Travel Controls (dash area)	●			
Boom Controls (right side)	●			
Hydraulic Test Ports			●	
Hourmeter (dash)	●			
Switches/Indicators (dash)	●			
Hydraulic Pump			●	
Hydraulic Filter (Reservoir)		●		
Misc. Hydraulic Valves			●	
Heater (lower front)	●			

 **WARNING**

DO NOT smoke or allow any open flames in the area while checking or servicing hydraulic, battery or fuel systems; all contain highly flammable liquids or explosive gases, which can cause an explosion or fire if ignited.

Wear a face shield when disassembling spring-loaded components or work with battery acid. Wear a helmet or goggles with special lenses when you weld or cut with a torch.

When working beneath a raised machine, always use blocks, jack-stands or other rigid and stable supports. Wear appropriate protective clothing, gloves, and shoes. Keep feet, clothing, hands and hair away from moving parts.

Always wear safety glasses or goggles for eye protection from electric arcs from shorts, fluids under pressure, and flying debris or loose material when the engine is running or tools are used for grinding or pounding.

NEVER weld on bucket, forks, boom, support frame or ROPS/FOPS without the consent of the manufacturer. These components may be made with metals that require special welding techniques, or with designs that do not allow weld repairs. NEVER cut or weld on fuel lines or tanks.

If repair welding is ever required, BE SURE to attach the ground (-) cable from the welder as close as possible to the area to be repaired. Also, remove battery positive (+) terminal connection before welding.

Choose a clean, level work area. Make sure you have sufficient room, clearances, and adequate ventilation. Clean the walking and working surfaces. Remove oil, grease and water to eliminate slippery areas. Utilize sand or oil absorbing compound, as necessary, while servicing the Telehandler.

Before starting inspection and repair, move the machine onto a level surface, shut down engine, and release all hydraulic pressure. Always block the boom securely, or lower it to full ground contact. Place all controls in neutral.

Block the wheels. Remove the ignition key. Remove only guards or covers that provide needed access. Wipe away excess grease and oil.

Excessively worn or damaged parts can fail and cause injury or death. Replace any cracked or damaged parts. Use only genuine Mustang parts for service.

Use care not to damage machined and polished surfaces. Clean or replace all damaged or painted-over plates and decals that cannot be read.

 **WARNING**

NEVER leave guards off or access doors open when the machine is unattended. Keep bystanders away if access doors are open.

After servicing, check the work performed, that no parts are left over, etc. Install all guards and covers.

Service Every 10 Hours or Daily

CHECK FUEL TANK LEVEL

After operation each day, the fuel tank should be filled to prevent water from condensing in the tank. To fill, remove the filler cap and add fuel.

CHECK ENGINE OIL LEVEL

With the machine on level ground, and the engine stopped for ten minutes or more, slide open the side engine panel and remove the engine dipstick. Wipe it clean, re-insert it and remove to obtain a reading. If the oil level is down, or below the ADD mark, fill with the required amount of oil to bring the level to the FULL mark. See the Lubrication chapter for the type of oil to use.

CHECK RADIATOR COOLANT LEVEL

 **WARNING**

DO NOT remove the radiator cap when the engine is running hot or overheated. Coolant is extremely hot and under pressure and it can burn your skin. Allow sufficient time for the radiator to cool BEFORE relieving the pressure and removing the radiator cap.

With the machine on level ground, remove the radiator cap. If the coolant level is below the filler neck, add a low-silicate ethylene glycol base coolant mixed with quality water and supplemental coolant additives (SCAs) suitable for heavy-duty diesel engines. See your engine manual for additional information. Replace the radiator cap securely.

NOTE: *If the engine is operated with a loose radiator cap, the pressure bypass will not work and the engine will run hot.*

CHECKING TRANSMISSION OIL LEVEL

The machine must be on level ground. With the engine and transmission at operating temperature parking brake on, transmission in neutral and engine speed at low idle, remove the access cover to the transmission and hydraulic pump. Remove the dipstick and check the oil level. Add the required amount of oil to bring the level to the FULL mark. See the Lubrication chapter for the type of oil to use.

CHECKING HYDRAULIC OIL LEVEL

The machine must be on level ground with boom lowered and completely retracted. The fluid MUST be cool when checking the reservoir level, to reduce the possibility of overfilling the hydraulic system.

Locate the filler cap next to the side view mirror on the right side of the machine. Remove the filler cap and check the level on the dipstick. If the oil level is down, or below the ADD mark, fill with the required amount of oil to bring the level to the FULL mark. See the LUBRICATION chapter for the type of oil to use.

IMPORTANT: *Be careful when removing the reservoir filler cap so that no dirt or other foreign matter enters the hydraulic system. DO NOT OVERFILL.*

CHECKING BRAKE RESERVOIR LEVELS

Flip up the cover on the cab floor in front of the seat. Remove both reservoir covers to check the fluid levels. If low, fill to the proper level with the correct fluid. See the Lubrication chapter for the type of fluid to use.

CHECKING TIRE PRESSURES

Proper tire pressure should be maintained for all four tires to enhance operating stability and extend tire life.

When installing tires on the machine, be sure that all tires are of the same size and style. ALWAYS replace tires with the same size furnished as original equipment. Replacement tires must be purchased locally.

Check the tire pressure “cold.” All 12-ply tires should be inflated to 55 PSI (380 kPa).

NOTE: *If the tires have been filled with water or calcium chloride for balast, a calcium chloride tire pressure gauge MUST be used to check the tire pressure.*

When removing tires, follow industry safety practices. Deflate completely prior to removal. After assembly of the tire onto the rim, use a safety cage or restraining device while inflating.

WARNING

Inflating or servicing tires can be dangerous. Whenever possible, trained personnel should service and mount tires. To avoid possible death or serious injury, follow the safety precautions below:

- 1. BE SURE the rim is clean and free of rust.**
 - 2. Lubricate both the tire beads and rim flanges with a soap solution. DO NOT use oil or grease.**
 - 3. DO NOT place your fingers on the tire bead or rim during inflation. Use a clip-on tire chuck with a remote hose and gauge, which allows you to stand clear of the tire while inflating it.**
 - 4. NEVER inflate beyond 35 PSI (240 kPa) to seat the beads. If the beads have NOT seated by the time the pressure reaches 35 PSI (240 kPa), deflate the assembly, reposition the tire on the rim, relubricate both parts and re-inflate. Inflation pressure beyond 35 PSI (240 kPa) with unseated beads may break the bead or rim with explosive force sufficient to cause death or serious injury.**
 - 5. After seating the beads, adjust the inflation pressure to the recommended operating pressure listed.**
 - 6. DO NOT weld, braze, or otherwise attempt to repair and use a damaged rim.**
-

CHECKING WHEEL NUT TORQUE

On new machines, or any time a wheel has been removed, re-torque wheel nuts until 450 ft-lbs (610 Nm) is maintained.

CHECKING INSTRUMENTS OPERATION

Allow the engine to warm up for about five minutes before beginning operation. Indicator lamps should be OFF and gauges should register normal readings. Tilt the frame from side to side with the frame leveling control and note the angle indicator movement.

CHECK GENERAL MACHINE OPERATION AND CONDITION

Are any decals missing or damaged? Are all guards, shields and covers in place? Do all controls function smoothly and properly? Are there any abnormal vibrations or noises? Are any hose or fitting connections leaking? Is the engine exhaust color normal?

WARNING

Manufacturers of push-pull control cables advise taking the following operation and maintenance precautions:

Do not adjust the control cable with the engine running.

A gradual or sudden increase in the no-load friction (cable disconnected at both ends) of a control cable is an indication of an impending or present performance problem. The control cable should be replaced.

A gradual or sudden decrease in the useable travel is a indication of an impending or present performance problem. The cable should be replaced.

Control cables that have moisture inside of them and/or have frozen should be replaced. Do not apply heat to thaw or dry control cables.

Control cable are lubricated for the life of the control cable. Do not remove the seals or lubricate the control cable.

Control cables are designed to be non-repairable. Do not attempt to repair control cables.

Failure to heed could result in death or serious injury.

CHECKING WORK PLATFORM SAFETY SYSTEM (if used)

WARNING

If the WPS System fails to operate properly during any of the WPS System checks, DO NOT USE the machine until the cause has been corrected. Contact your dealer (or Mustang Manufacturing Company) for service information and parts.

Machine Position

The following must be performed before beginning the WPS System checking procedures:

1. Machine on level surface,
2. Boom fully lowered,
3. Frame level,
4. Transmission in "N" (Neutral),
5. Parking brake switch "OFF,"
6. WPS System switch "OFF,"
7. Remote switch plugged in and "ENGAGED."

Activation Tests

To test the WPS System activation logic:

1. Start the engine and press the WPS rocker switch "ON."
 - The WPS System lamp in the switch should be flashing.
2. Apply the service brakes.
 - The WPS switch lamp should be illuminated continuously after three seconds, indicating that the WPS System has been activated.
 - The parking brake should engage, as indicated by the lamp on the parking brake switch illuminating.

- The carriage tilt and auxiliary functions, should now be disabled. The hydraulic joystick should continue to function normally for boom raise/lower and extend/retract.

Lockout Tests

To test the transmission and joystick control lockout logic:

1. Shift transmission into “F” (Forward) and increase the engine speed slightly.
 - The transmission should remain de-clutched, allowing the engine to increase speed easily.
 - Return the transmission selector to “N” (Neutral) after the check.
2. Have an assistant move the remote shutdown switch to “Dis-engaged.”
 - The hydraulic joystick should now be disabled, so that boom raise/lower and extend/retract will no longer function.
 - Have the assistant move the remote shutdown switch to “Engaged” after the check.
3. Tilt the frame to the right slightly more than two degrees.
 - The hydraulic joystick should now be disabled so that boom raise/lower and extend/retract no longer function.
 - Repeat the procedure with the frame tilted to the left.
 - Return the frame to a level position after the checks.

De-activation Tests

To test the WPS System de-activation logic:

1. Turn the key switch to “OFF” and wait for the engine to stop. Then turn the key switch back to “ON.”
 - The WPS switch lamp and the parking brake switch lamp should both be illuminated.
2. Turn the key switch “OFF” and then turn the WPS rocker switch to “OFF.” Turn the key switch back “ON.”
 - The WPS switch lamp should be flashing and the parking brake switch lamp should be on continuously.
3. Start the engine and apply the service brakes.
 - The WPS switch lamp and the parking brake switch lamp should go off after approximately

three seconds of brake pedal application.

If WPS System fails to perform properly, troubleshoot using the chart on page 56. Contact your dealer for service information and parts.

Service Every 50 Hours or Weekly

LUBRICATE GREASE POINTS

Refer to the Lubrication chapter of this manual for weekly grease fitting locations and other related details.

CHECKING FUEL FILTER

NOTE: *The fuel filter will require occasional replacement to maintain a clean and adequate fuel flow for maximum engine horsepower. The frequency of filter replacement will be determined by the cleanliness of available fuel, the care used in storing fuel supplies and the operating conditions in which the machine is used.*

Small amounts of water can be drained from the fuel filter. The drain plug should be removed weekly to drain off water accumulation until clear fuel is flowing from the outlet.

A drain plug is also provided in the bottom of the fuel tank for removing condensation and other foreign materials. Open the plug and allow water and fuel to drain into a container until only clear fuel is flowing from the tank.

100 Hours (New Machine Only)

The following initial oil and filter changes should be made at 100 hours on a new machine. Thereafter these changes should be made at the regular maintenance schedule listed below. Refer to those schedules for the necessary procedures.

Engine Oil and Filter	(250 Hours)
Transmission Oil and Filter	(1000 Hours)
Hydraulic Return Filter Element	(1000 Hours)

Service Every 250 Hours or Quarterly

NOTE: *Perform all other service requirements up to this point, as well as the following:*

CHECKING AXLE OIL LEVELS

Differential

NOTE: *The Telehandler should be on a level surface for this procedure.*

See illustration. Remove the oil check plug. Oil should flow from the hole. If low, remove the oil fill plug and add oil until it flows from the check hole. Replace the plug, wait 10 to 15 minutes and repeat the fill procedure. Continue this process until the differential is full. See the Lubrication chapter for the proper oil specification. Replace the check and fill plugs.

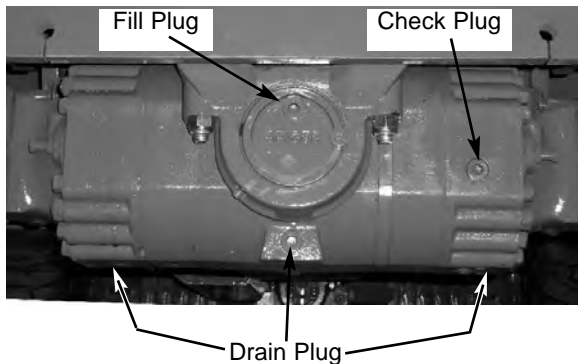

Planetary Hubs

NOTE: *The planetary hubs can be checked without jacking up the machine.*

See illustration below. The planetary hubs have one plug each used for filling and draining. For checking the level and filling, position the wheel until the oil level arrow is horizontal. Remove the plug. If oil does not run out, add oil until it overflows. Check the remaining hubs the same way. Refer to the oil specifications found in the Lubrication chapter of this manual.

Plug in fill and check position.

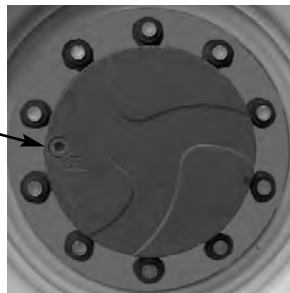

CHANGING FUEL FILTER

The frequency of filter replacement will be determined by the cleanliness of available fuel, the care used in storing fuel supplies and the operating conditions in which the machine is used.

WARNING

NEVER service the fuel system while smoking, while near an open flame, or after the engine has been operated and is hot.

After fuel filter replacement, bleed the air out of the fuel system following the procedures in the engine manual.

Fuel Bleeding Procedures

When the fuel filter is removed and replaced, or the engine runs out of fuel, air must be bled from the system. Refer to the engine manual for proper bleeding procedures.

If the engine still will not start, consult your authorized engine dealer.

NOTE: *Only an authorized engine dealer can perform warranty service on the engine.*

Diesel Fuel Injectors

Whenever faulty or plugged injectors are indicated, see your authorized engine dealer.

Diesel Injection Pump Timing

Whenever injection pump timing, or other pump service is indicated by abnormal engine operation, contact your engine dealer.

WARNING

Escaping diesel fuel under pressure can have sufficient force to penetrate the skin. Before applying pressure to the fuel system, BE SURE all connections are tight and lines and hoses are not damaged. Use a piece of wood or cardboard to search for suspected leaks. If injured by escaping fuel, see a doctor familiar with this type of injury at once or gangrene may result.

CHANGING ENGINE OIL AND FILTER

Change the engine oil and filter using the following procedure:

1. With the engine warm, remove the crankcase drain plug. Some plugs are equipped with a magnet to gather metal particles. Completely clean and flush

away all metallic filings from the plug and re-install it.

IMPORTANT: *DO NOT discharge oil onto ground. Catch and dispose of per local waste disposal regulations.*

2. The engine oil filter should be changed at every oil change interval. Remove and discard the disposable filter canister. Wipe the gasket sealing area of the block with a clean cloth.

IMPORTANT: *Your OEM engine oil filters have special by-pass valves built in. Use only genuine OEM engine replacement filters.*

3. Apply a thin coat of clean oil to the new oil filter gasket. Hand tighten. Refill the crankcase with new oil. Follow specifications in the Lubrication chapter for type and viscosity of new oil.
4. After new oil has been added, run the engine at idle speed until the oil pressure lamp is OFF. Check for leaks at the filter and drain plug. Re-tighten only as much as necessary to eliminate leakage.

CHECKING THE BATTERY

The battery furnished in the machine is a 12-volt, wet-cell battery.

The top of the battery must always be kept clean. Clean the battery with a brush dipped in an alkaline solution (ammonia or baking soda and water). After the foaming has stopped, flush the top of the battery with clean water. If the terminals and cable connection clamps are corroded or have a buildup, disconnect the cables and clean the terminals and clamps with the same alkaline solution.

WARNING

Explosive gas is produced while a battery is in use or being charged. Keep flames or sparks away from the battery area. Make sure battery is charged in a well-ventilated area.

NEVER lay a metal object on top of a battery as a short circuit can result.

Battery acid is harmful on contact with skin or fabrics. If acid spills, follow these firstaid tips:

1. **IMMEDIATELY remove any clothing on which acid spills.**

2. **If acid contacts the skin, rinse the affected area with running water for 10 to 15 minutes.**
3. **If acid comes in contact with the eyes, flood the eyes with running water for 10 to 15 minutes. See a doctor at once. NEVER use any medication or eye drops unless prescribed by the doctor.**
4. **To neutralize acid spilled on the floor, use one of the following mixtures:**
 - a. **1 pound (0.5 kg) of baking soda in 4 quarts (4 liters) of water.**
 - b. **1 pint (0.4 liters) of household ammonia in 4 quarts (4 liters) of water.**

Whenever battery is removed from the unit, BE SURE to disconnect the negative (-) battery terminal connection first.

Jump Starting

If the battery becomes discharged or does not have enough power to start the engine, use jumper cables and the following procedure to jump-start the engine.

WARNING

The ONLY safe method for jump-starting a discharged battery is for TWO PEOPLE to perform the following procedure. The second person is needed for removing the jumper cables so that the operator does not have to leave the operator's compartment while the engine is running. NEVER connect the jumper cables directly to the starter solenoid of either engine. DO NOT start the engine from any position other than the operator's seat, and then ONLY after making sure all controls are in "neutral."

Closely follow the jump-start procedures, in the order listed, to avoid personal injury. In addition, wear safety glasses to protect your eyes, and avoid leaning over the batteries while jump-starting.

DO NOT attempt to jump-start the machine if the battery is frozen, because this may cause it to rupture or explode.

IMPORTANT: *BE SURE that the jumper battery is also a 12-volt D. C. battery, and the vehicle used for jump starting has a negative-ground electrical system.*

1. Turn the keyswitches on both vehicles to “OFF”. Be sure that both vehicles are in “Neutral” and NOT touching.
2. Connect one end of the positive (+) jumper cable to the positive (+) battery terminal on the disabled machine first. DO NOT allow the positive (+) jumper cable clamps to touch any metal other than the positive (+) battery terminals. Connect the other end of the positive jumper cable to the jumper battery positive (+) terminal.
3. Connect one end of the negative (-) jumper cable to the jumper battery negative (-) terminal.
4. Make the final negative (-) jumper cable connection to the disabled machine’s engine block or frame (ground) - NOT to the disabled battery negative post. If making the connection to the engine, keep the jumper clamp away from the battery, fuel lines, or moving parts.

NOTE: *Twist the jumper cable clamps on the battery terminals to ensure a good electrical connection.*

5. Proceed to start the machine. If it does not start immediately, start the jumper vehicle engine to avoid excessive drain on the booster battery.
6. After the machine is started and running smoothly, have the second person remove the jumper cables (negative (-) jumper cable first) from the jumper vehicle battery, and then from the disabled machine, while ensuring NOT to short the two cables together.

Allow sufficient time for the alternator to build up a charge in the battery before operating the machine or shutting off the engine.

NOTE: *If the battery frequently becomes discharged, have the battery checked for possible dead cells, or troubleshoot the electrical system for possible short circuits or damaged wire insulation.*

CHECKING AND TORQUING BOOM LEAF CHAINS

Inspect the leaf chains for wear and proper tension.

Two of the chains are on the top front of the boom. A third chain is accessible from inside the rear of the boom (see boom illustration).

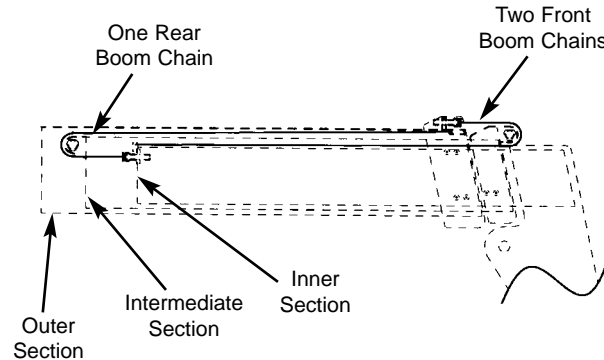

Chain Hookup Detail

Run the boom out slowly to inspect. Conditions to look for include cracked or broken plates, protruding or turned pins, excessive wear. With a steel tape, measure 16 links of the strand that flexes over the sheaves. When the distance measures 10.3” (262 mm), the chain should be replaced. DO NOT repair sections of a chain. Replace the complete chain.

Chain anchors and sheaves also require inspection for wear or broken fingers and worn flanges.

If any chain has been replaced, operate under loaded conditions and re-check the torque. Adjust the chains per the following procedure. Extend the boom to its maximum length. Then retract the boom slowly until the chain slack allows the chain to rest on the top of the boom. Torque the chains on the front of the boom to 25 ft-lb (34 Nm). Lubricate with 80W90 oil.

CHECKING BOOM SLIDE PAD WEAR AND CLEARANCE

The boom is equipped with special nylon low friction slide pads between the telescopic sections (see illustration). These are pre-greased and initially worn-in at the factory. Normally greasing is not required, except for maintaining a light film of grease on the pad tracking areas of the boom sections. An exception would be if a boom section has been replaced.

Visually check for loose pad bolts. The bolts are torqued to 30 ft-lb (40 Nm). If the bolts are re-torqued at any time, Loctite® thread lock must be re-applied to the bolts.

If the boom starts to chatter under load, grease the slide pads and wipe off the excess. If a top or side slide pad shows excessive wear, loosen bolts and insert shims to each side or top and bottom for even distribution of

clearance. Re-apply Loctite® thread lock to the bolts and re-torque to 30 ft-lbs (40 Nm). Bottom slide pads should be replaced when the thickness is worn down to 3/8" (9.5 mm).

WARNING

Failure to maintain proper slide pad clearance and thickness could cause damage to the boom, resulting in sudden boom failure.

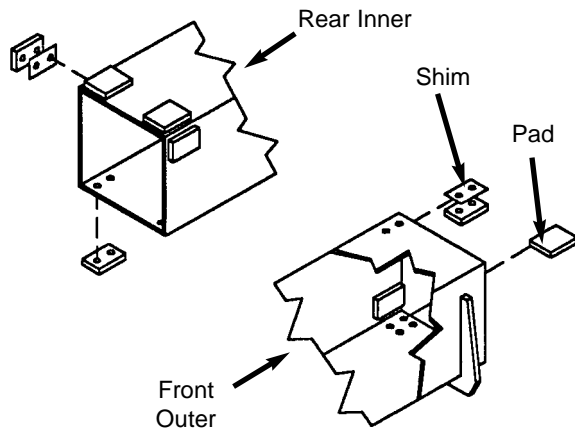

Slide Pad Detail

CHECKING PERSONNEL WORK PLATFORM SYSTEM

Follow the procedure for checking the WPS System as outlined on page 48.

Service Every 1000 Hours or Yearly

NOTE: Perform all other service requirements up to this point, as well as the following:

CHANGING TRANSMISSION OIL AND FILTER

Operate the machine long enough to warm up the transmission oil. Shut down the engine. Access to filter and drain plug is from underneath the machine. Proceed as follows:

1. Remove the drain plug and drain old oil. Replace the drain plug.

IMPORTANT: DO NOT discharge oil onto ground. Catch and dispose of per local waste disposal regulations.

2. Remove and discard the oil filter. Wipe the sealing surface on the transmission with a clean cloth. Apply a thin coat of clean oil to the new oil filter gasket. Hand tighten.
3. Refill the transmission with new oil as shown in the Lubrication chapter of this manual.

IMPORTANT: DO NOT OVERFILL! If the oil level is too high, oil foaming, excessively high oil temperature and oil leakage at the seals could result.

4. Start and run the machine long enough for the oil to circulate and warm slightly. Recheck the level with the dipstick.

CHANGING RADIATOR COOLANT

Drain, flush and refill the cooling system as follows:

IMPORTANT: DO NOT discharge coolant onto ground. Catch and dispose of per local waste disposal regulations.

1. Loosen the radiator cap to its stop. This will release any system pressure. Remove the cap when all pressure is bled off.

WARNING

Remove the radiator cap only when the engine is cool, or painful burns could result.

2. Open the radiator drain cock. Remove the water jacket drain plug from the engine block. When all coolant is drained, flush the system with clean fresh water. Allow the flush to drain completely.
3. Replace all drain plugs and tighten the radiator drain cock. Clean the cooling fins in the radiator with water pressure or steam.

IMPORTANT: Fill the cooling system with a low-silicate ethylene glycol base coolant mixed with quality water and supplemental coolant additives (SCAs) suitable for heavy-duty diesel engines. See your engine manual for additional information.

4. Inspect the radiator cap seal before installing it. Replace it if it appears to be damaged. The 10 PSI (69 kPa) pressure cap and engine thermostat work in conjunction with each other to maintain proper engine cooling.

NOTE: Check the engine temperature gauge every minute or two after coolant has been changed. Air pockets can form and it may be necessary to refill the cooling system after a short period of use, as the air will naturally bleed out of the system.

CHANGING HYDRAULIC RETURN FILTER ELEMENT



WARNING

Lower the boom to the ground when servicing the hydraulic system.

This element is a cartridge type accessible from a housing on top of the hydraulic reservoir. Initial replacement is after the first 100 hours. See illustration. Remove the top cover of the housing. Remove the element and discard. Insert the new element into the housing and replace the cover.

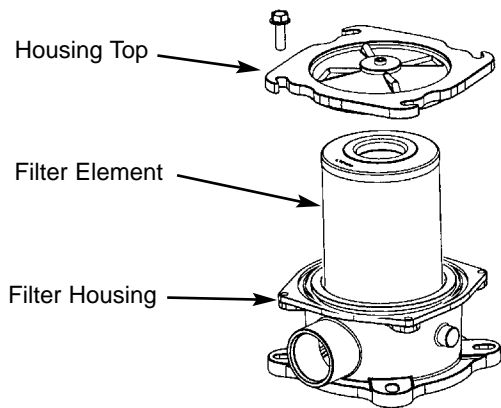

Reservoir Filter Removal

CHANGING AIR FILTER ELEMENTS

IMPORTANT: Failure to follow proper filter servicing instructions could result in catastrophic engine damage.

The air cleaner assembly consists of an outer (primary) filter element and an inner (secondary) filter element. An air filter restriction indicator for monitoring the condition of the elements is located in the rubber elbow at the rear of the air cleaner. If the air filter becomes restricted, this indicator turns red to warn the operator that the air cleaner requires service. Push the reset button located at the end of the indicator after replacing the element

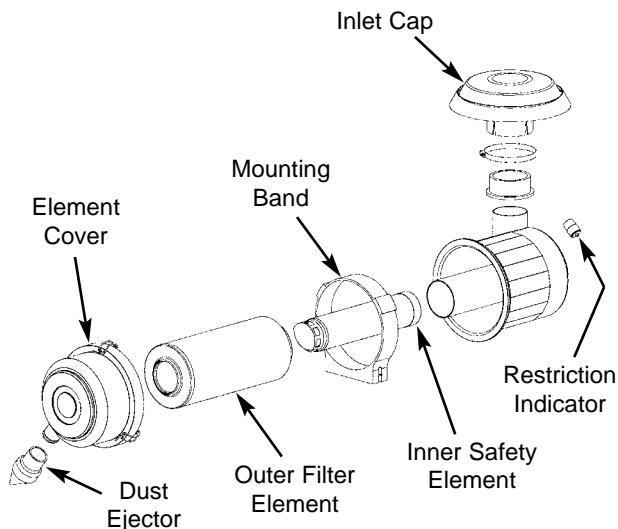

Air Cleaner Assembly

NOTE: Before replacing the filter element(s), push the reset button on the indicator. Start the engine and run at full throttle. If the indicator does not turn red, do not replace the element(s).

The outer element should be replaced when the restriction indicator turns red. The inner element should be replaced every third time the outer element is replaced, unless the outer element is damaged or the inner element is visibly dirty. Along with a daily check of the restriction indicator, check that the air cleaner intake hose and clamps, and the mounting bracket hardware are properly secure.

Unlatch the three latches on the air cleaner and remove the cover. Clean out any dirt in the cover assembly.

Outer Element

1. Carefully pull the outer element out of the housing. Never remove the inner element unless it is to be replaced.
2. Clean out any dirt in the housing. Leave the inner element installed during this step to prevent debris from entering the engine intake manifold.
3. Use a trouble light inside the new outer element to inspect for bad spots, pinholes and ruptures. Replace the outer element if any damage is found. The outer element must be replaced if it is oil- or soot-laden.

NOTE: Cleaning the outer element is not recommended.

Inner Element

NOTE: Replace the inner element only if it is visibly dirty or if the outer element has been replaced three times.

Before removing the inner element from the housing, clean out any dirt in the housing. Leave the inner element installed during this step to prevent debris from entering the engine intake manifold. Remove the inner element.

Reinstallation

IMPORTANT: NEVER use an element that is damaged. Severe engine wear and eventual failure can result if dirt gets through a hole in the element.

1. Check inside the housing for any damage that may interfere with the elements.
2. Be sure that the element sealing surfaces are clean.
3. Insert the element(s), making sure that they are seated properly.
4. Secure the cover to the housing with the three clamps.
5. Check the hose connections and make sure they are all clamped and tightened properly.

NOTE: Keep spare elements on hand to eliminate down time.

CHANGING AXLE DIFFERENTIAL AND PLANETARY OIL

Differentials

1. Remove the three drain plugs and drain out the old oil. Replace the drain plugs (see illustration).

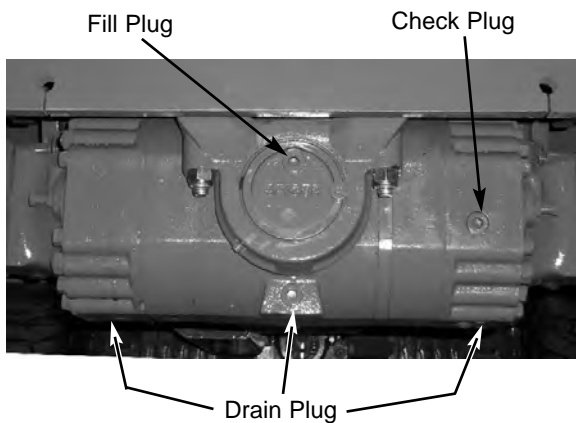

IMPORTANT: DO NOT discharge oil onto ground. Catch and dispose of per local waste disposal regulations.

2. Remove the check and fill plugs. Fill the differential with oil as specified in the Lubrication chapter. When the oil flows the check hole, replace the plug. Wait 10 to 15 minutes and repeat this process until the axle is full. Repeat this procedure with the other axle.

Axle Planetary Hubs

The hubs have one plug each used for draining and filling (see illustration).

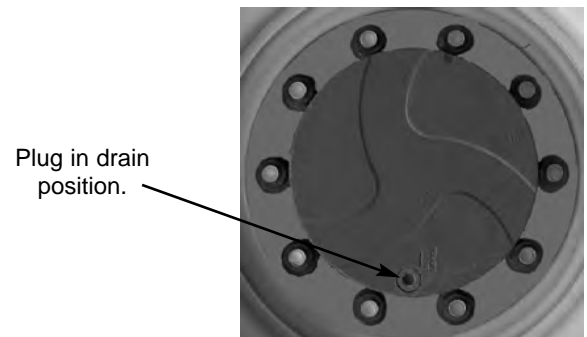

1. Position the wheel until the oil level arrow points down. Remove the drain/fill plug and allow the oil to drain out. Replace the plug.

IMPORTANT: DO NOT discharge oil onto ground. Catch and dispose of per local waste disposal regulations.

2. Re-position the hub so the oil level arrow is horizontal. Fill with fresh oil as specified in the Lubrication chapter. When the oil runs out, install the drain/fill plug. Repeat this procedure on the three remaining hubs.

CHECKING ALTERNATOR AND FAN BELT CONDITON

Refer to the engine manual for proper belt tension adjustment and replacement procedures. If the belt shows wear or cuts, it should be replaced. Order replacement belt from your engine dealer.

CHECKING EXHAUST SYSTEM

Examine the muffler and tail pipe for possible holes. Re-tighten any loose clamps and make sure the manifold outlet gasket is not leaking.

Service Every 2000 Hours or Two Years

NOTE: Perform all other service requirements up to this point, as well as the following.

CHECKING HYDRAULIC SYSTEM RELIEF PRESSURES

Pressure settings for relief valves are pre-set at the factory. Three test ports are provided under the front hood access cover.



Test ports under access cover

Before conducting any test port pressure checks, check the engine RPM. Engine speed must be 800 RPM at idle and 2500 to 2550 RPM at high idle.

Steering Relief Pressure

Plug a 3000 psi (207 bar) oil- or liquid-filled gauge into the test port labeled "SP." Turn the steering full to the right or left. The gauge should read 2000 psi (138 bar).

Joystick and Parking Brake Release Pressure

Plug a 1000 psi (70 bar) gauge into the port labeled "JP." With the engine running, the gauge should read 400-425 psi (27-29 bar).

Main Relief Pressure

Plug a 3000 psi (207 bar) oil- or liquid-filled gauge into the test port labeled "MP." Fully retract the boom over the relief valve. The gauge should read 3000 psi (207 bar).

CHANGING HYDRAULIC RESERVOIR OIL AND STRAINER

Clean all dirt and debris from around the top of the reservoir, especially around the access cover. Refer to illustration and use the following procedure:

1. Remove the drain plug and drain oil. Wash or blow off all particles collected on the magnetic drain plug.

IMPORTANT: DO NOT discharge oil onto ground. Catch and dispose of per local waste disposal regulations.

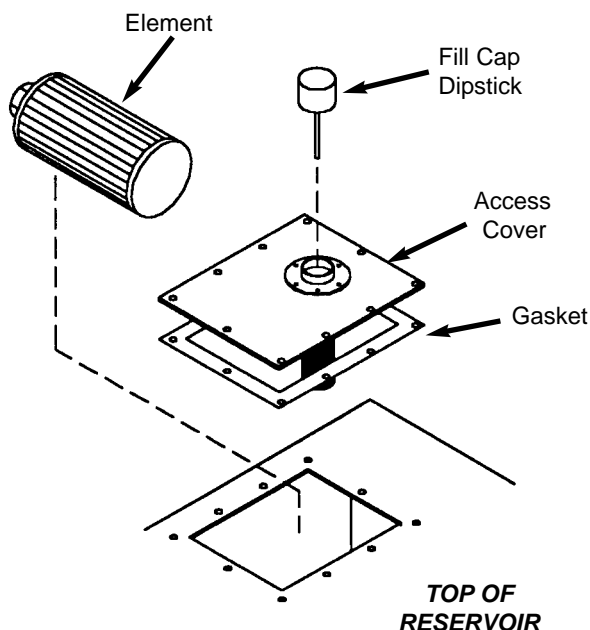

Hydraulic Reservoir Sump Strainer Removal

2. Remove the access cover and wash the inlet screen with clean solvent. Remove the sump filter strainer from the bottom inside of the reservoir. Wash it also. If the strainer has any damage, holes, etc., it should be replaced.
3. Flush out the bottom of the tank with clean hydraulic oil. Re-install all cleaned components and put the access cover back on the reservoir with a new gasket. Clean the filter/breather cap.
4. Fill the tank with fresh oil. Follow specifications found in the Lubrication chapter of this manual.



WARNING

Escaping hydraulic oil under pressure can have sufficient force to penetrate the skin. Before applying pressure to the hydraulic system, be sure all connections are tight and lines and hoses are not damaged. Use a piece of wood or cardboard to search for suspected leaks. If injured by escaping hydraulic oil, see a doctor familiar with this type of injury immediately or gangrene may result.

IMPORTANT: *Hydraulic fluid and filters should be replaced any time contamination is present before the normally scheduled change.*

STORAGING

If the Telehandler will not be operated for a long period of time, prepare and store it using the following procedure:

Before Storage

Perform the following prior to placing the machine in storage:

1. Wash the entire machine.
2. Lubricate all grease fittings as described in the Lubrication chapter of this manual.
3. Change engine oil as outlined in the Service and Storage chapter of this manual.
4. If the machine will not be operated for a month or longer, apply grease to all exposed hydraulic cylinder rod areas.
5. Disconnect the battery cable clamps and cover the battery, or remove the battery from the machine and store it separately.
6. If the ambient temperature (at any time during the storage period) is expected to drop below freezing, make sure the engine coolant is either completely drained from the radiator and engine block or that the amount of anti-freeze in it is adequate to keep the coolant from freezing. Refer to the engine manual for anti-freeze recommendations and quantities.

During Storage

1. About once each month, connect the battery and, before starting the engine, check all fluid levels to make sure they are at the proper level.
2. Start the engine and allow it to run until it warms up. Then move the machine a short distance to help relubricate the internal parts. Run the engine until the battery has a chance to recharge, and then shut it off.

IMPORTANT: *If it is desired to operate the hydraulic cylinders at this time, BE SURE to wipe the protective grease (and any adhering dirt) from the cylinder rods prior to starting the engine. After operating, if the machine is to be returned to storage recoat the cylinder rods with grease.*

After Storage

After removing the machine from storage and BEFORE operating it, perform the following:

1. Change engine oil and filter to remove any condensation and residues.
2. Wipe off grease from cylinder rods.
3. Lubricate ALL grease fittings.
4. Follow the starting and warm-up procedures outlined in the Operation and Adjustments chapter of this manual.

WPS SYSTEM OPERATIONAL TROUBLESHOOTING

Problem	Possible Cause	Remedy
<p>WPS System mode lamp flashes when switch is turned "ON".</p> <p>Parking brake did not engage when the WPS System switch is turned "ON".</p> <p>Carriage tilt and auxiliary functions continue operating when the WPS System switch is turned "ON".</p> <p>Transmission does not remain de-clutched when shifted into "FORWARD or REVERSE" when the WPS System switch is "ON".</p>	<p>WPS System not activated.</p>	<p>With WPS System switch "ON", apply service brakes for two seconds until WPS System mode lamp is on continuously.</p>
<p>Boom control functions do not operate.</p>	<p>Machine is not level.</p> <p>Remote WPS System switch is de-activated.</p> <p>Remote WPS System switch is not plugged into the connector at the end of the boom.</p> <p>WPS System level sensor unplugged or faulty.</p>	<p>Level the machine.</p> <p>Activate the remote WPS System switch.</p> <p>Plug in and engage the remote WPS System switch.</p> <p>Contact your Mustang dealer for assistance.</p>
<p>WPS System mode lamp flashes when switch is turned "OFF".</p> <p>Parking brake lamp stays "ON" when WPS System switch is turned "OFF".</p>	<p>WPS System is not de-activated.</p>	<p>With engine running, apply service brakes for two seconds until WPS System mode lamp goes off.</p>

Chapter 9

DECAL LOCATIONS

GENERAL INFORMATION



CAUTION

ALWAYS read and follow the safety precautions on decals. Replace decals if they are damaged, or if the unit is repainted. If repainting, **BE SURE** that all applicable decals are affixed in their proper locations.

Decal locations information is provided to assist in the proper selection and application of new decals, in the event the original decals become damaged or the machine is repainted.

For correct replacement of decals, compare the location illustrations to your machine before starting to refinish the unit. Check off each required decal using the illustration reference number to find the part number, description and quantity in the list. Refer to the appropriate illustrations for replacement locations.

NOTE: Refer to the Safety chapter of this manual for the specific information provided on the various safety decals.

NEW DECAL APPLICATION

Before applying the new decals, surfaces must be free from dirt, dust, grease and other foreign material. To apply a solid-formed decal, remove the smaller portion of the decal backing paper and apply this part of the exposed adhesive backing to the clean surface while maintaining proper position and alignment. Slowly peel off the other portion of the backing paper while applying hand pressure to smooth out decal surface. To apply a die-cut decal, first remove the backing paper. Then, properly orient and position the decal onto the clean mounting surface. After the decal is firmly applied and smoothly pressed down, remove the front covering paper.

PAINT FINISH

Use this list to order paint for refinishing:

184771	One Gallon Yellow
910101	6 (12 oz. Spray Cans) Yellow
184765	One Gallon Gray
910100	6 (12 oz. Spray Cans) Gray

Decal Kits

103377	634 Telehandler without WPS
103378	634 Telehandler with WPS

NOTE: Decals may be purchased in kits or individually.

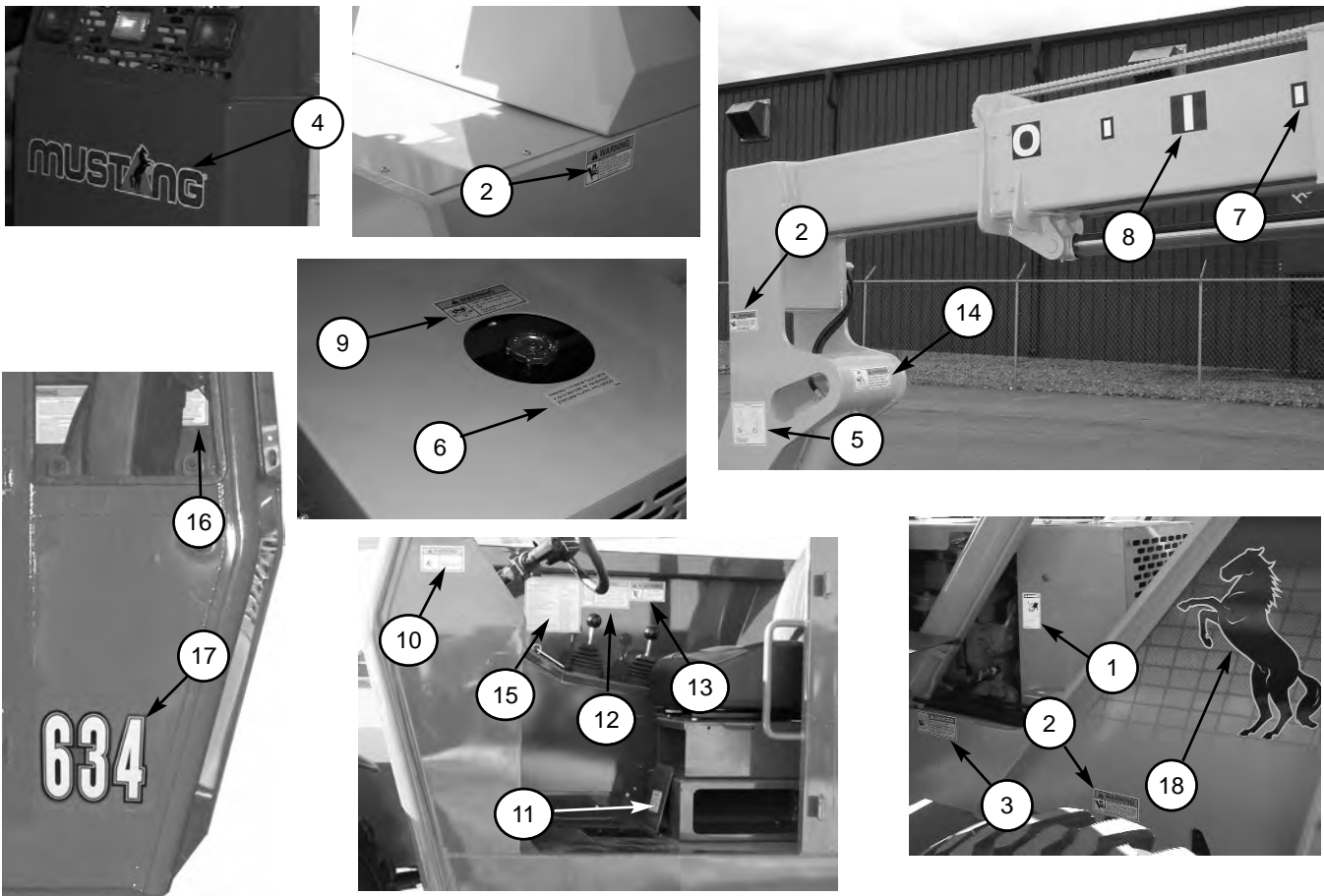

DECAL LOCATIONS - FRAME AND BOOM

REF. NO.	DESCRIPTION	PART NO.
01	DANGER - HANDS OUT	L70305
02	WARNING - PINCH POINT	L65927
03	WARNING - JUMP START	L65933
04	MUSTANG - REAR	100155
05	QUICKATTACH DIAGRAM	L65937
06	ANTI-FREEZE	056859
07	HALF ZONE MARKER (5 ea.)	L62583
08	NO. "0" EXTENSION MARKER (1 ea.)	L67718
	NO. "1" EXTENSION MARKER (1 ea.)	L67719
	NO. "2" EXTENSION MARKER (1 ea.)	L67720
09	NO. "3" EXTENSION MARKER (1 ea.)	L67721
	NO. "4" EXTENSION MARKER (1 ea.)	L67722
	NO. "5" EXTENSION MARKER (1 ea.)	L67723
10	COOLANT UNDER PRESSURE	072798
	WARNING - NO RIDERS	L65932
11	BRAKE FLUID	L63474
12	OPERATOR MANUAL WARNING	100359
13	DANGER-PERSONNEL INJURY (<i>units without WPS</i>)	L65928
14	CARRY LOAD LOW	L65926
15	LUBE CHART	103229
16	ROPS & FOPS CERTIFICATION	103227
17	634 LH	100627
18	HORSE - LH UPRIGHT	100624

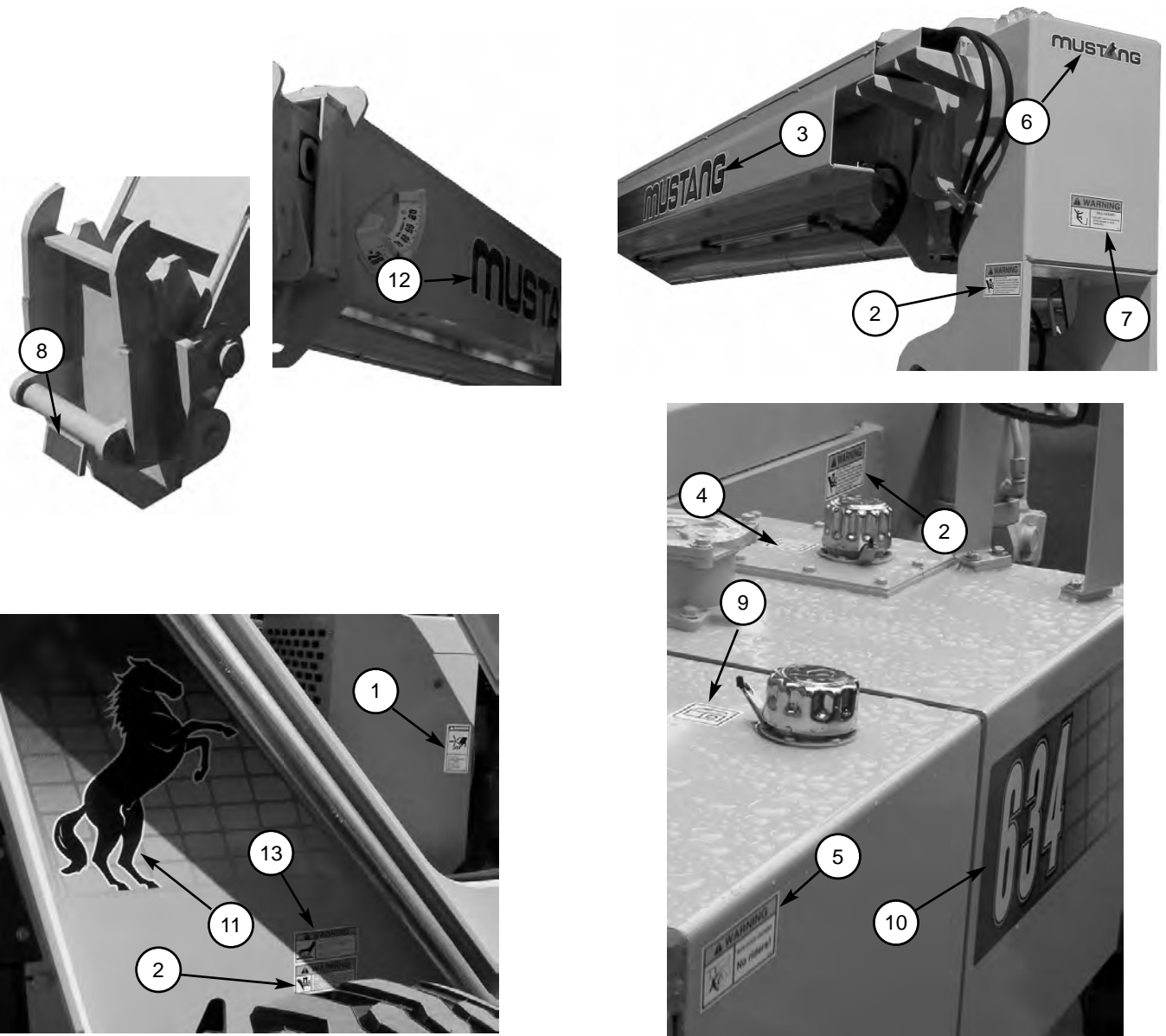

DECAL LOCATIONS - FRAME AND BOOM

REF. NO.	DESCRIPTION	PART NO.
01	DANGER - HANDS OUT	L70305
02	WARNING - PINCH POINT	L65927
03	MUSTANG RH BOOM	100623
04	HYDRAULIC OIL FILL	137632
05	WARNING - NO RIDERS	L65932
06	MUSTANG - FRONT	100156
07	DANGER-PERSONNEL INJURY <i>(units without WPS)</i>	L65928
08	QUICKATTACH UNLOCKED	L66613
09	DIESEL FUEL	137634
10	634 RH	100626
11	HORSE - RH UPRIGHT	100625
12	MUSTANG LH BOOM	100622
13	HOT SURFACE	L65942

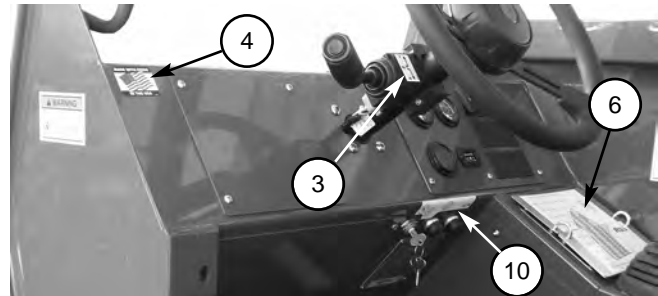
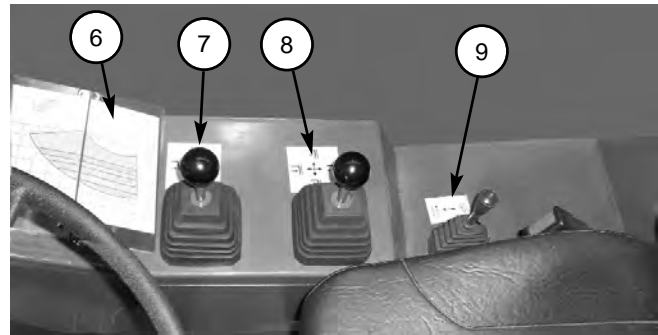
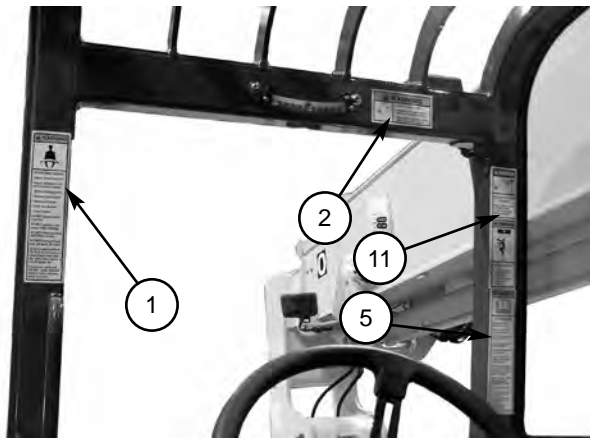

DECAL LOCATIONS - OPERATOR STATION

REF. NO.	DESCRIPTION	PART NO.
01	WARNING-TILT HAZZARD/GENERAL OPERATOR	L70306
02	WARNING - CARRY LOAD LOW	L65926
03	F-N-R SHIFT	L68295
04	MADE IN USA	140516
05	WARNING - PARK BRAKE/SEAT BELT	101506
06	STANDARD CARRIAGE LOAD CHART ROTATING CARRIAGE LOAD CHART BUCKET LOAD CHART TRUSS BOOM LOAD CHART WINCH LOAD CHART	100657 103341 100660 100659 100661
07	ATTACHMENT TILT/FRAME LEVEL	L63632
08	BOOM CONTROL	L63631
09	AUXILIARY HYDRAULIC CONTROL <i>(Optional)</i>	102718
10	IGNITION/START/HORN	102717
11	DANGER-HI VOLT./MOVING PARTS	L70307

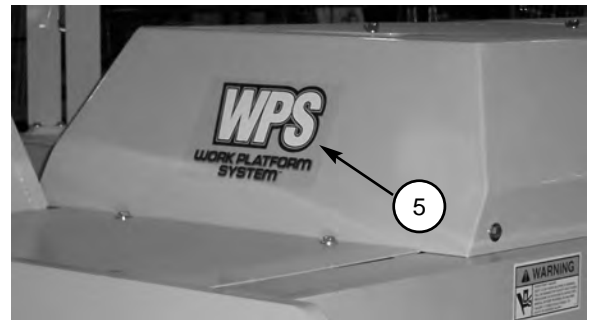
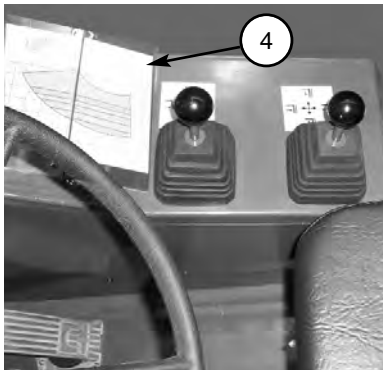
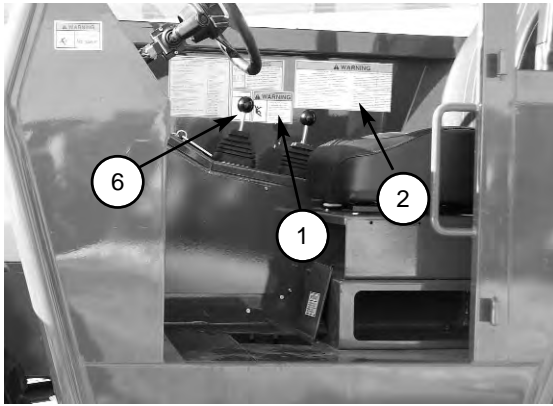

DECAL LOCATIONS - WPS EQUIPPED UNITS

REF. NO.	DESCRIPTION	PART NO.
01	WARNING-PERSONNEL LIFT	L71554
02	WARNING-WORK PLATFORM RULES	L71555
03	PERSONNEL LIFT SAFETY RULES	L71700
04	WPS LOAD CHART	103340
05	WPS LOGO	103016
06	WPS SWITCH	102969

Chapter 10

MAINTENANCE

This Maintenance Interval Chart was developed to match the Service and Storage chapter of this manual. Detailed information on each Service Procedure may be found in the Service and Storage chapter. A Maintenance Log follows the Maintenance Interval Chart for recording the maintenance procedures performed. Recording the 10-Hour (or Daily) service procedures would be impractical and is therefore not recommended.

IMPORTANT: *Under extreme operating conditions, more frequent service than the recommended intervals may be required. You must decide if your operation requires more frequent service.*

MAINTENANCE INTERVAL CHART

SERVICE PROCEDURE	Every 10 Hours (or Daily)	Every 50 Hours (or Weekly)	First 100 Hours	Every 250 Hours (or Quarterly)
Checking Fuel Tank Level	●			
Checking Engine Oil Level	●			
Checking Radiator Coolant Level	●			
Checking Transmission Oil Level	●			
Checking Hydraulic Oil Level	●			
Checking Brake Reservoir Level	●			
Checking Tire Pressures	●			
Checking Wheel Nut Torque	● ^{1,2}			
Checking Instruments Operation	●			
Checking General Machine Operation and Condition	●			
Checking Personnel Work Platform Safety System	●			
Lubricate Grease Points		●		
Checking Fuel Filter (Drain Water If Required)		●		
Changing Engine Oil and Filter			● ²	
Changing Transmission Oil and Filter			● ²	
Changing Hydraulic Oil Filter			● ²	
Checking Axle Oil Levels				●
Changing Fuel Filter				●
Changing Engine Oil and Filter				●
Checking Battery				●
<p><i>1 - On new machines or when a wheel has been removed until 450 Ft-Lbs (610 Nm) is maintained.</i> <i>2 - Only new machines.</i></p>				

MAINTENANCE INTERVAL CHART (CONT.)

SERVICE PROCEDURE	Every 250 Hours (or Quarterly)	Every 1000 Hours (or Yearly)	Every 2000 Hours (or Two Years)
Checking and Torquing Boom Leaf Chains Checking Boom Slide Pad Wear and Clearance Checking Personnel Work Platform System Changing Transmission Oil and Filter	● ● ●	●	
Changing Radiator Coolant Changing Hydraulic Return Filter Element Changing Air Filter Element Changing Axle Differential and Planetary Oil		● ● ● ●	
Checking Alternator and Fan Belt Condition Checking Exhaust System Checking Hydraulic System Relief Pressures Changing Hydraulic Reservoir Oil and Strainer		● ●	● ●

MAINTENANCE LOG

Date	Hours	Service Procedure

MAINTENANCE LOG

Date	Hours	Service Procedure

MAINTENANCE LOG

Date	Hours	Service Procedure

Hydraulic Schematic w/o WPS

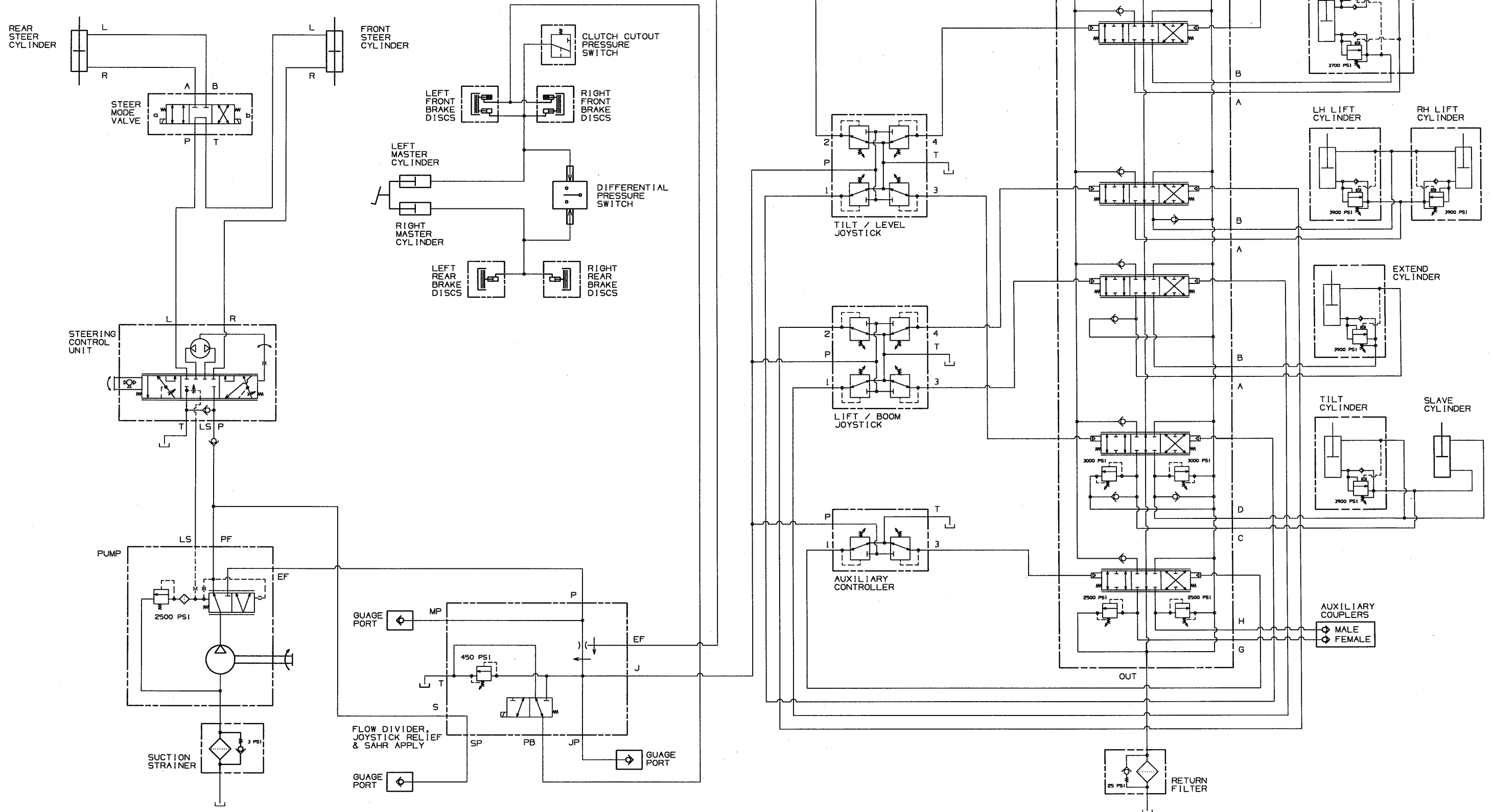

Hydraulic Schematic with WPS

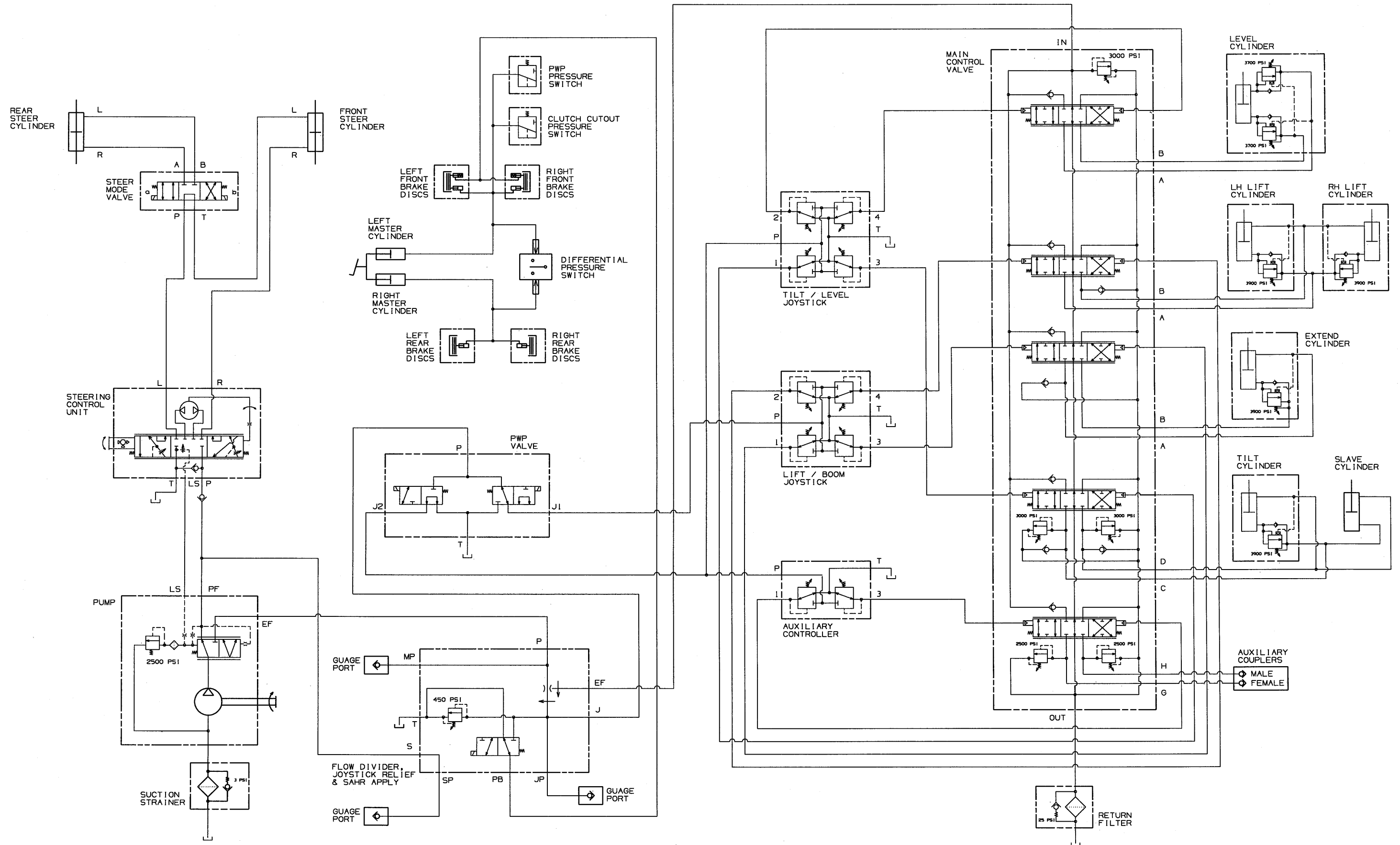

Electrical Schematic

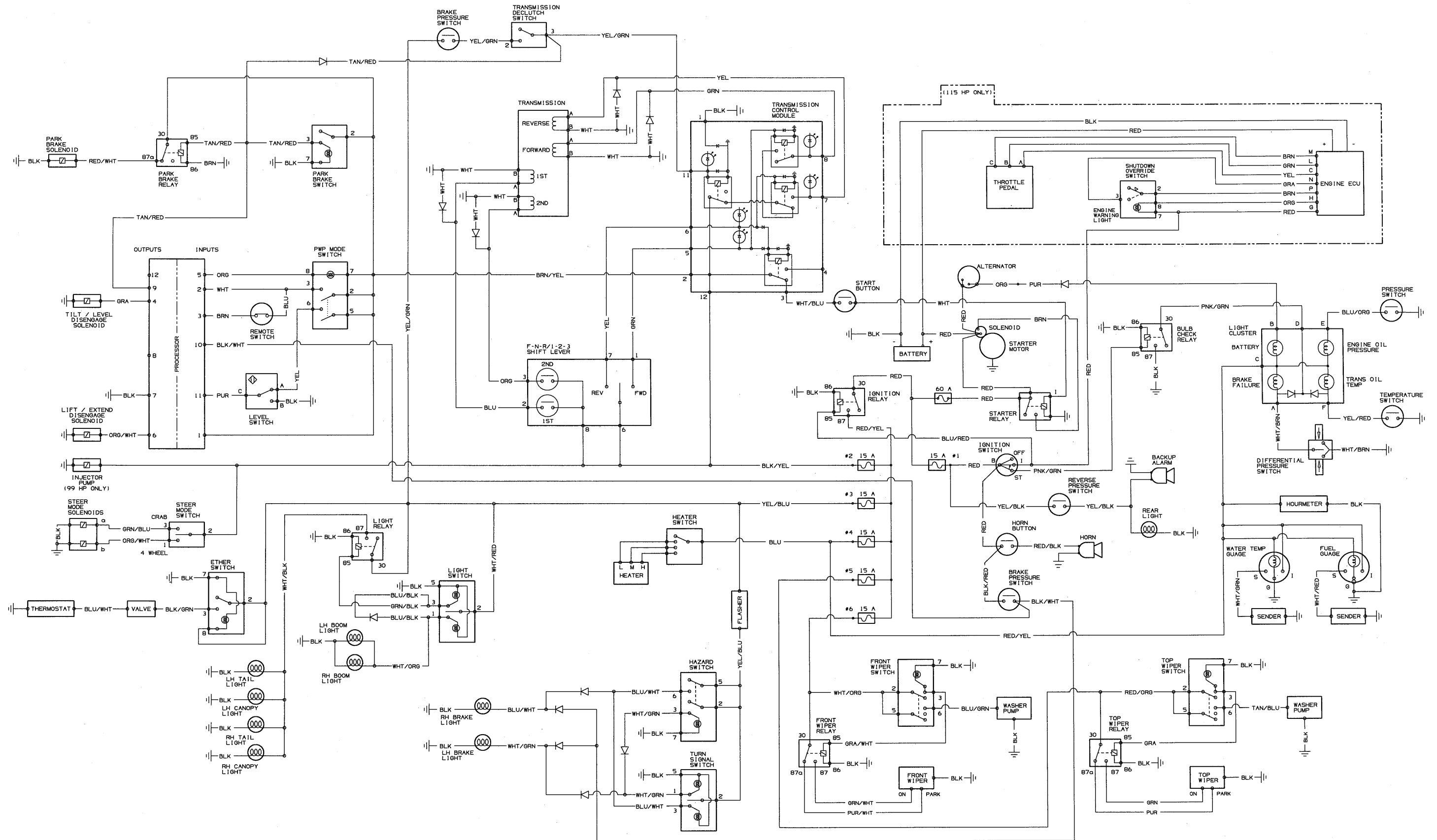

INTENTIONALLY BLANK

INTENTIONALLY BLANK

Load Zone Charts

Decal 100657
Standard Carriage

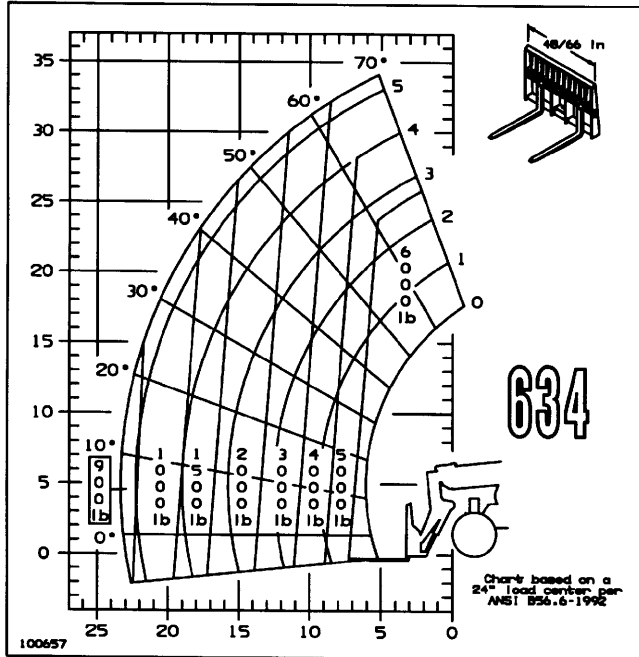

Decal 100660
1.3 Cu. Yd. Bucket

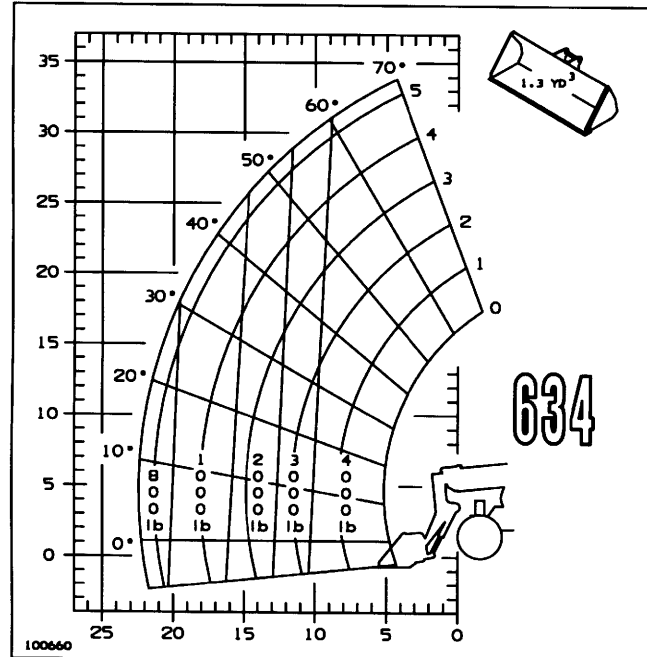

Decal 103341
Rotating Carriage

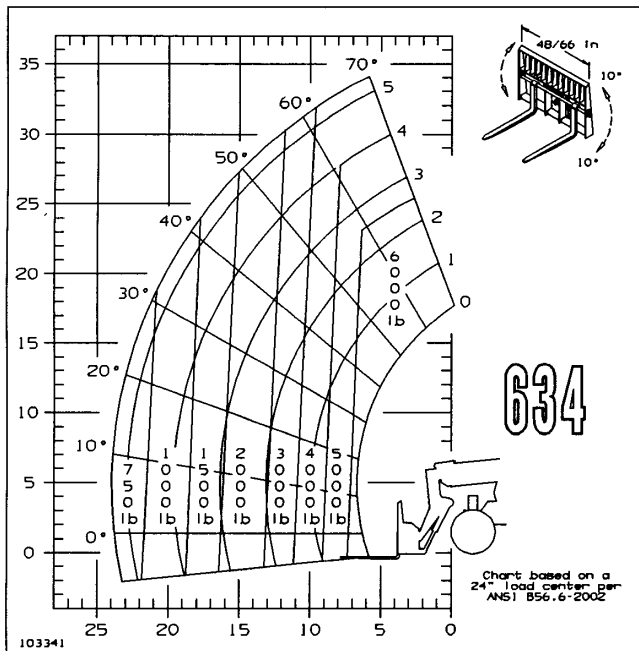

Decal 100659
8-Ft. Truss Boom

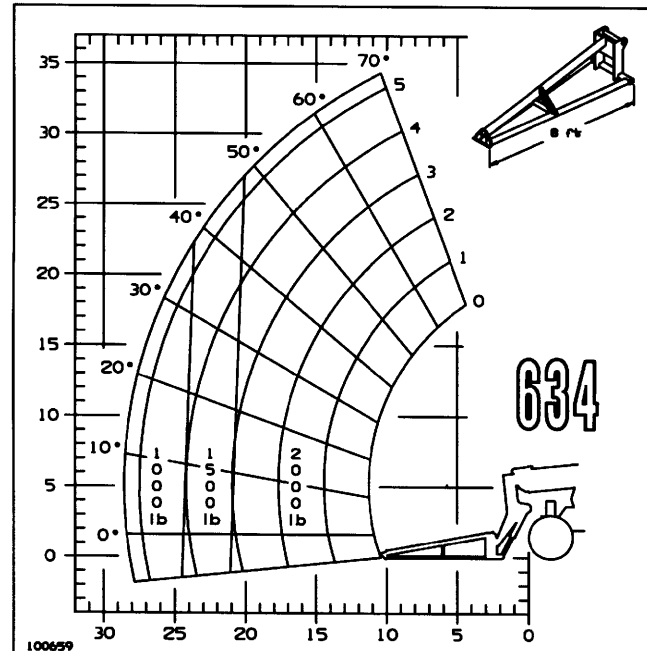

Load Zone Charts

**Decal 100661
Winch Boom**

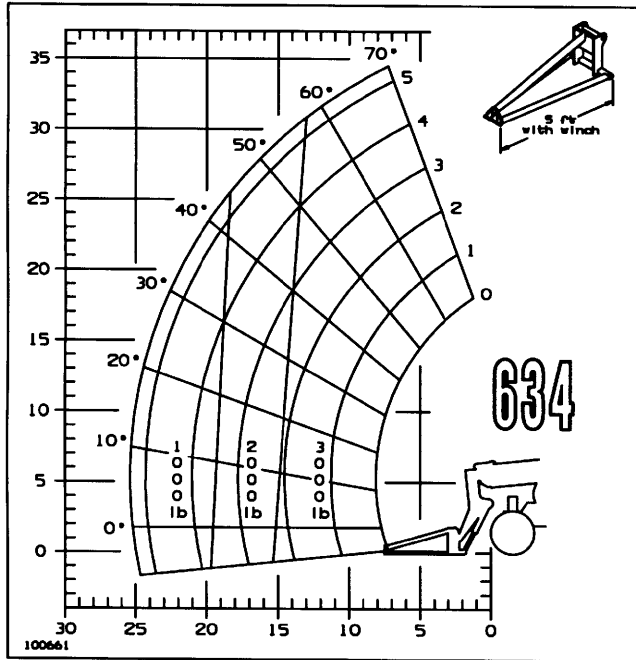



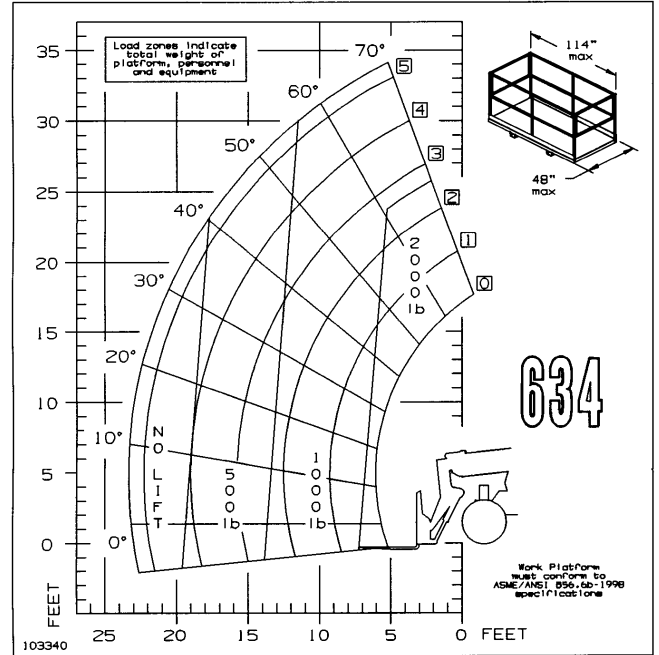



**Decal 103340
WPS**



Torque Specifications

Use these torque values when tightening Mustang hardware (excluding: locknuts and self-tapping, thread-forming and metal screws) unless otherwise specified.

Unified National Thread	Grade 2 		Grade 5 		Grade 8 	
	Dry	Lubed	Dry	Lubed	Dry	Lubed
8-32	19*	14*	30*	22*	41*	31*
8-36	20*	15*	31*	23*	43*	32*
10-24	27*	21*	43*	32*	60*	45*
10-32	31*	23*	49*	36*	68*	51*
1/4-20	66*	50*	9	75*	12	9
1/4-28	76*	56*	10	86*	14	10
5/16-18	11	9	17	13	25	18
5/16-24	12	9	19	14	25	20
3/8-16	20	15	30	23	45	35
3/8-24	23	17	35	25	50	35
7/16-14	32	24	50	35	70	55
7/16-20	36	27	55	40	80	60
1/2-13	35	35	75	55	110	80
1/2-20	40	40	90	65	120	90
9/16-12	55	55	110	80	150	110
9/16-18	60	60	120	90	170	130
5/8-11	75	75	150	110	220	170
5/8-18	85	85	180	130	240	180
3/4-10	130	130	260	200	380	280
3/4-16	150	150	300	220	420	320
7/8-9	125	125	430	320	600	460
7/8-14	140	140	470	360	660	500
1-8	190	190	640	480	900	680
1-14	210	210	710	530	1000	740

Metric Course Thread	Grade 8.8 		Grade 10.9 		Grade 12.9 	
	Dry	Lubed	Dry	Lubed	Dry	Lubed
M6-1	8	6	11	7	13.5	10*
24M8-1.25	19	14	27	20	32.5	24*
M10-1.5	37.5	28	53	39	64	47
M12-1.75	65	48	91.5	67.5	111.5	82
M14-2	103.5	76.5	145.5	108	176.5	131
M16-2	158.5	117.5	223.5	165.5	271	200

* All torque values are in lb-ft except those marked with an *, which are in lb-in.
For metric torque value (Nm), multiply lb-ft x 1.355 or lb-in value x 0.113.

Index

A

Access To Components Chart	47
Accessories	29
Adjustments	
Slide Pads Clearance	54
Wheel Lug Nuts Torque	50
Air Filter	
Service Element	56
Alternator	
Belt Service	57
Indicator Lamp	24
Anti-freeze - See Radiator	
Attachment Tools	
Changing	32
Operating Methods - See Chapter 6	
Axles	
Description - See Chapter 2	
Greasing	44
See Also Service	
Axle Oil	
Change	57
Check Levels	51
Recommended Grades	43

B

Backup Alarm	29
Battery	
Charging Lamp	24
Jump Starting	53
Service	53
Boom Travel	
Function Controls	28
Function Indicators	28
Service	54

C

Capacities - See Chapter 2	
Carriage Lifting Applications	
Load Capacity and Reach	36
Load Carry, Elevation and Placement	37
Checklists, delivery and pre-delivery	5,7
Controls,	
Dash	24
Right Side Panel	27

Floor and Seat	27
Other Miscellaneous	28
Cylinders	
Servicing	46

D

Dealer Services	46
Decal Locations	62
Decals, applying new	61
Dimensions - See Chapter 2	

E

Electrical Components	
Characteristics - See Chapter 2	
Controls and Indicators - See Chapter 4	
Servicing	47
Engine	
Cold Weather Start Procedures	31
Description - See Chapter 2	
Oil Pressure Lamp	24
Starting	30
Temperature Gauge	24
Engine Oil	
Changing	52
Check Level	48
Recommended Grades	43
Engine Shutdown Protection	
Engine Coolant Temperature	32
Engine Oil Pressure	31
Engine Override Shutdown Switch	25
Engine Oil Filter, replacing	52
Exhaust System, check	57

F

Fan Belt - See Alternator Belt	
Frame Level Control and Indicator	27
Fuel - See Separate Engine Manual	
Fuel Filter	
Check and Drain Water	51
Replacing	52
Fuel Gauge	24
Fuse Access	29

G

Grease Fittings	
Locations	.44
Types Of Grease	.43
Guards	.23
Grade and Slope Precautions	.34
Grade Limits	.34

H

Hand Signals	.35
Hourmeter	.25
Hydraulic Components, servicing	.46
Hydraulic Oil	
Change	.58
Check level	.49
Recommended type	.43
Hydraulic Maintenance	
Oil Filters, replacing	.56
Oil Sump Strainer, replacing	.58
Pressure Checks	.57
Hydraulic Pump, servicing	.46
Hydraulic Valves, servicing	.46

I

Identification Reference	.3
Indicators	.24
Indicator Symbols	.Inside Front Cover
Introduction	.2

J

Joystick Pressure Setting	.58
---------------------------	-----

L

Light Switch	.26
Load Zone Charts	.76
Lubrication,	
<i>See also Service Intervals</i>	
Locations	.44
Lubricants	.43

M

Main Relief pressure check	.58
Maintenance	
Recording	.67
Scheduled Intervals	.66
Mandatory SAFETY Shutdown Procedure	.8
Mandatory Work Platform Safety Rules	.12

O

Oils - See Lubrication	
Operation	
Load Handling	.35
Starting	.30
Stopping	.31
Symbols	.Inside Front Cover
Travel	.39
Operator Manual, storing	.2
Operator Services	.47
Operator Training	.21
Operator's Station	
Environment Controls	.26

P

Park Brake Switch	.26
Park Brake Pressure Setting	.58
Paint, refinish	.61
Pump, Delivery Rates - See Chapter 2	

Q

Quickattach System	
Attach/Detach Mechanism	.32

R

Radiator	
Check coolant	.48
Cleaning	.55
Flushing and Refilling	.55
Relay Access	.29
Road Travel	.39

S

SAFETY	.8
Decals	.15
Schematics	
Electrical	.74
Hydraulic	.70
Seat, operator's	.27
Service and safety Features	.29
Service Intervals	
Daily	.48
Weekly	.51
100 hours	.51
250 hours	.51
1000 hours	.55
2000 hours	.57

Shields	23
Side View Mirror	29
Specifications	4
Steering - See Controls	
Steering Relief Pressure Check	58
Storage	59
Suspended Loads	39
Guidelines For Free Rigging / Suspended Loads	39

T

Tables	
Lubricants	43
Paint Notice	61
Replacement Filters	44
Theft Deterrents	40
Tire Pressures	49
Torque Specifications	78
Traffic Flow Patterns	34
Transmission	
Description - See Chapter 2	
Temperature Lamp	25
Transmission Oil	
Changing	55
Check Level	49
Recommended Grades	43
Transporting	
Loading	40
Unloading	40
Travel Speed - See Controls	
Troubleshooting, WPS	60

W

Warranty	Inside Rear Cover
Water Trap - See Fuel Filter	
Windshield Wiper Switch	26
Work Platform Checking Procedure	50
Work Platform Design Requirements	13
Work Platform Safety Decals	20
Work Platform Safety Rules	12
Work Platform Safety System	12
Work Platform Switch	26

MUSTANG MANUFACTURING COMPANY, INC.

WARRANTY

MUSTANG MANUFACTURING COMPANY, INC., hereinafter referred to as Mustang, warrants new Mustang equipment to the Original Retail Purchaser to be free from defects in material and workmanship for a period of twelve (12) months from the Warranty Start Date.

MUSTANG WARRANTY SERVICE INCLUDES:

Genuine Mustang parts and labor costs required to repair or replace equipment at the selling dealer's business location.

MUSTANG MAKES NO REPRESENTATIONS OR WARRANTIES OF ANY KIND, EXPRESS OR IMPLIED (INCLUDING THE IMPLIED WARRANTIES OF MERCHANTABILITY AND FITNESS FOR PARTICULAR PURPOSE), EXCEPT AS EXPRESSLY STATED IN THIS WARRANTY STATEMENT.

ANY OF THESE LIMITATIONS EXCLUDED BY LOCAL LAW SHALL BE DEEMED DELETED FROM THIS WARRANTY; ALL OTHER TERMS WILL CONTINUE TO APPLY.

SOME STATES DO NOT PERMIT THE EXCLUSION OR LIMITATION OF THESE WARRANTIES AND YOU MAY HAVE GREATER RIGHTS UNDER YOUR STATE LAW.

MUSTANG WARRANTY DOES NOT INCLUDE:

1. Transportation to selling dealer's business location or, at the option of the Original Retail Purchaser, the cost of a service call.
2. Used equipment.
3. Components covered by their own non-Mustang warranties, such as tires, batteries, trade accessories and engines.
4. Normal maintenance service and expendable, high-wear items.
5. Repairs or adjustments caused by: improper use; failure to follow recommended maintenance procedures; use of unauthorized attachments; accident or other casualty.
6. Liability for incidental or consequential damages of any type, including, but not limited to lost profits or expenses of acquiring replacement equipment.

No agent, employee or representative of Mustang has any authority to bind Mustang to any warranty except as specifically set forth herein.



**THIS OPERATOR'S MANUAL IS
PROVIDED FOR OPERATOR USE**

**DO NOT REMOVE
FROM THIS MACHINE**

Do not start, operate or work on this machine until you have carefully read and thoroughly understand the contents of the operator's manual.

Failure to follow safety, operating and maintenance instructions could result in serious injury to the operator or bystanders, poor operation, and costly breakdowns.

If you have any questions on proper operation, adjustment or maintenance of this machine, contact your dealer or the service department of Mustang Manufacturing Company before starting or continuing operation.

California Proposition 65 Warnings

Diesel engine exhaust and some of its constituents are known to the State of California to cause cancer and birth defects or other reproductive harm.

Battery posts, terminals and related accessories contain lead and lead compounds, chemicals known to the State of California to cause cancer and birth defects or other reproductive harm. **Wash hands after handling battery.**