

Master Parts Manual

Compact Track Loader

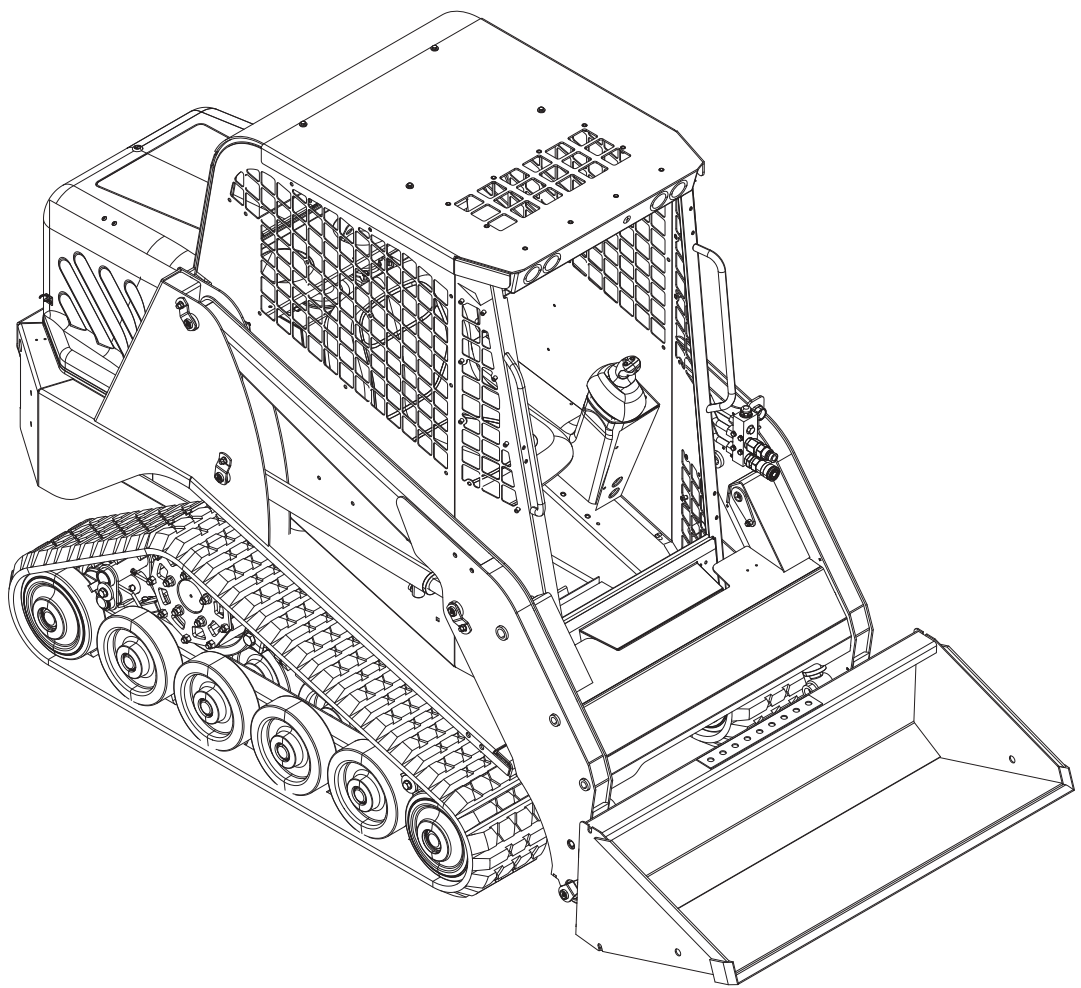

RT-30
R070T

Part Number: 2010-884
Printed 05-09-2015

Table of Contents

1. **Service Parts**
 - 1-1 General Service Items / Lubricants
 - 1-2 Cylinder Service Items
 - 1-3 Harnesses
2. **Fuel/Engine**
 - 2-1 Diesel Engine
 - 2-2 Cooling System
3. **Hydraulic Components**
 - 3-1 Hydraulic Reservoir
 - 3-2 Lift Arm Assembly
 - 3-3 Lift Arm Tubes and Fittings
 - 3-4 Hydraulic Control
 - 3-5 Drive Auxilliary Pump
4. **Electrical**
 - 4-1 Light Bar Assembly
 - 4-2 Fuse Panel
5. **Undercarriage**
 - 5-1 Torsion Axle
 - 5-2 Undercarriage Assembly, RT
 - 5-3 Undercarriage Assembly, LT
6. **Mainframe**
 - 6-1 Chassis
 - 6-2 Hood Assembly
7. **Cab / Heating / Air Conditioning**
 - 7-1 Cab
 - 7-2 Enclosed Cab
 - 7-3 Cab Heat

8. **Quick Attach**
 - 8-1 Quick Attach
 - 8-2 Quick Attach Adarter
9. **Graphics / Safety Decals**
 - 9-1 ANSI Safety Decals
 - 9-2 ISO Safety Decals
 - 9-3 Machine Graphics

* This manual covers illustrations and parts lists for U.S, Australian, and New Zealand machines, and is updated on a regular basis. Always refer to the current online version to ensure you have the most up to date information prior to ordering parts.

NOTE: Ordering parts that are painted requires a specific part number format. Please refer to page II of this manual for paint code and ordering information.

Painted Service Parts

ordering guidelines

Compact Track and Skid Steer Loaders are available in various colors and nomenclatures (brands / model names). **Paint color needs to be specified when ordering painted components.** When ordering painted components, inform the support representative of the brand and model name of your machine before selecting the proper color from the list below. The support representative should be able to assist you in finding the correct one based on your machine's **VIN number**. This should help to identify the original machine configuration and nomenclature.

***Note: Not all colors are available on all components. Available colors are limited to those considered "standard" on your particular machine and component(s).** Please do not attempt to order non-standard colors for your machine as the order will not be fulfilled until corrected.

The color codes are to be referenced as a suffix to the part number of the component you are requesting, for example: 0000-000-GRN (indicating a green part).

The following is a list of available colors.

<u>Color</u>	<u>Color Code:</u>
BLACK	BLK (ALL MODELS)
WHITE	WHT (TEREX)
YELLOW	YEL (VERMEER)
YELLOW	YEY (ASV)
GREEN	GRN (SUNBELT)
RED	RED (TAKEUCHI)
GRAY	GRY (TEE)
GRAY	GTG (SKID STEER WHEELS ONLY)
ORANGE	ORN (ASPLUNDH)

Charter 1

Service Parts

<u>1-1 General Service Items / Lubricants.....</u>	1-1A
<u>1-2 Cylinder Service Items</u>	1-2A
<u>1-3 Harnesses</u>	1-3A

* This manual covers illustrations and parts lists for U.S, Australian, and New Zealand machines, and is updated on a regular basis. Always refer to the current online version to ensure you have the most up to date information prior to ordering parts.

GENERAL SERVICE ITEMS & LUBRICANTS

<u>ITEM</u>	<u>MANUFACTURER/DESCRIPTION</u>	<u>PART NUMBER</u>
Engine Oil Filter	Filter, Oil	0200-377
Primary Air Filter	Filter, Air	0304-434
Secondary Air Filter	Filter, Air	0304-435
Engine Fuel Filter	Filter, Fuel	0200-213
Fan Belt	Belt, Fan	2010-117
Antifreeze/Coolant (1 gal.)	Ethylene Glycol (long life)	0300-766
Antifreeze/Coolant (Case/6 gal.)	Ethylene Glycol (long life)	0402-841
Engine Oil (1 qt.)	Multi-Grade 10W-30	0300-767
Engine Oil (Case/12 qt.)	Multi-Grade 10W-30	0402-838
Engine Oil (1 gal.)	Multi-Grade 10W-30	0402-839
Engine Oil (Case/6 gal.)	Multi-Grade 10W-30	0402-840
Grease (1 Tube)	Multi-Purpose Lithium	0300-769
Grease (Box/10 Tubes)	Multi-Purpose Lithium	0402-844
Grease (Case/40 Tubes)	Multi-Purpose Lithium	0402-834

HYDRAULIC SERVICE ITEMS & LUBRICANTS

<u>ITEM</u>	<u>DESCRIPTION</u>	<u>PART NUMBER</u>
Hydraulic Oil Filter	Element,Filter,MP	0200-204
Kit,Seal,Loader Valve & Relief	Fits Loader Valve (P/N:2010-830)	2010-777
Kit,Seal,Bucket/Tilt Cylinder	Fits Cylinder (P/N:2010-827,2010-828)	2010-548
Rod,Bucket/Tilt Cylinder	Fits Cylinder (P/N:2010-827,2010-828)	2010-549
End Gland,Bucket/Tilt Cylinder	Fits Cylinder (P/N:2010-827,2010-828)	2010-550
Nut,Bucket/Tilt Cylinder	Fits Cylinder (P/N:2010-827,2010-828,2010-832)	2010-551
Kit,Seal,Lift Arm Cylinder	Fits Cylinder (P/N:2010-832)	2010-552
End Gland,Lift Arm Cylinder	Fits Cylinder (P/N:2010-832)	2010-553

<u>O-RING</u>	<u>PART NUMBER</u>
# 4, ORB Type	0314-366
# 6, ORB Type	0310-619
# 8, ORB Type	0307-353
# 10, ORB Type	0310-620
# 12, ORB Type	0310-621
# 16, ORB Type	0307-354
# 20, ORB Type	0310-832

HARNESSES

<u>ITEM</u>	<u>PART NUMBER</u>
HARNESS,WIPER,A W/LO	0304-572
HARNESS,WIPER,B	0304-573
HARNESS,HEATER W/LOO	0304-575
HARNESS,JUMPER,QA	2015-042
HARNESS GAUGE 4 UNIT	2030-276
RT-30 valid from - 06870	
RO70T valid from - 00101	
HARNESS MAIN RT30 PW	2010-687
HARNESS CAB RT30 PWR	2010-688
HARNESS AUX PWR ACT	2010-689

Charter 2

Engine

2-1 Engine

RT-30 Serial # valid from - 06870. 2-1A

R070T Serial # valid from - 00101. 2-1A

2-2 Radiator / Oil Cooler

RT-30 Serial # valid from - 06870. 2-2A

R070T Serial # valid from - 00101. 2-2A

- * **This manual covers illustrations and parts lists for U.S, Australian, and New Zealand machines, and is updated on a regular basis. Always refer to the current online version to ensure you have the most up to date information prior to ordering parts.**

NOTE: Ordering parts that are painted requires a specific part number format. Please refer to page II of this manual for paint code and ordering information.

ENGINE ASSEMBLY

RT-30 valid from - 06870
RO70T valid from - 00101

Charter 2

REF. NO.	PART NUMBER	QTY.	DESCRIPTION	REF. NO.	PART NUMBER	QTY.	DESCRIPTION
1	8040-726	4	NUT,HEX,NYLOCK,5/8-11 UNC,ZN	41	8040-366	2	NUT,HEX,NYLOCK,1/4-20 UNC,ZN
2	0090-431	4	WASHER, 2.5" OD X .64" ID X .179	42	0300-455	1	CABLE,THROTTLE
3	0300-458	4	MOUNT,ENGINE,REAR	43	2010-461	1	CABLE,BATTERY,NEGATIVE
4	0303-238	2	CLAMP,HOSE	44	2010-462	1	CABLE,BATTERY,POSITIVE
5	0304-282	1	HOSE,INTAKE,ID2"x4"	45	0304-131	10	CAPSCREW,HH, M14-1.5 X30MM,GD8
6	0304-034	1	ASSY,AIR CLEANER,3013	46	0304-130	1	WLMT,MNT,ENGINE
7	8102-561	4	CAPSCREW,HH,5/8-11UNCx3.00,GD8	47	0200-377	1	FILTER,OIL,ENGINE
8	0304-128	1	WLMT,MNT,ENGINE	48	0300-732	4	CLAMP,HOSE,#4
9	0304-900	1	MNT,PLATE,PUMP	49	0304-509	2	HOSE,FUEL,5/16x26"
10	0304-507	1	PLATE,FLYWHEEL	50	0304-549	1	HEATER,BLOCK
11	2011-028	1	ENGINE PERKINS SERVICE REPLACEMENT	51	0200-312	1	ASSY,TAIPIPE
12	0304-129	1	WLMT,MNT,ENGINE	52	0200-213	1	FILTER,FUEL,PERKINS,404C22
13	0404-001	1	STARTER	53	0301-389	2	CAPSCREW,HH,M10 x 1.50 x 30,ZN
14	0304-503	1	VALVE,DUST	54	0301-781	2	WASHER,SPLIT LOCK,10mm,ZN
15	0304-434	1	FILTER, AIR,PRIMARY,3013	55	0301-780	2	NUT,HEX,10mm x 1.5,ZN
16	0304-435	1	FILTER, AIR,SAFETY,3013	56	8102-132	8	CAPSCREW,HH,5/16-18UNCx1.0 GD8
17	0304-038	1	BAND,MNT,AIR CLEANER	57	0300-546	1	CABLE,GROUND,ENGINE
18	0307-720	3	CAPSCREW,HH,M8x1.25x20	58	0304-127	1	WLMT,MNT,ENGINE
19	8051-242	19	WASHER,SPRING LOCK,5/16,ZN	59	8051-272	10	WASHER,SPRING LOCK,3/8,ZN
20	2010-102	1	WLMT,FILTER,AIR	60	8102-225	4	CAPSCREW,HH,3/8-16 UNCx1.5,GD8
21	8040-426	2	NUT,HEX,NYLOCK,5/16-18 UNC,ZN	61	0201-585	1	HOSE,FUEL,5/16,19"
22	8102-134	2	CAPSCREW,HH,5/16-18UNCx1.25GD8	62	0304-835	1	BULB,PRIMER
23	8050-247	2	WASHER,WROUGHT,5/16,SAE,ZN	63	2055-190	1	HOSE,BREATHER,5/16,6"
24	0300-211	4	CAPSCREW,M8 x 1.25 x 25MM LG	64	0403-642	1	PIN CLIP
25	0304-511	1	GASKET,MUFFLER	65	0304-819	1	LATCH,COVER,AIR CLEANER
26	0200-334	1	TAILPIPE,OUTLET	66	0300-211	4	CAPSCREW,M8 x 1.25 x 25MM LG
27	0300-263	1	CLAMP,MUFFLER,2"	67	0304-839	10	WASHER,SPRING LOCK,14MM
28	4010-097	1	MUFFLER	68	8102-222	8	CAPSCREW,HH,3/8-16 UNCx1.0,GD8
29	2010-117	1	BELT,FAN	69	0200-333	1	TAILPIPE,CENTER
30	2045-565	1	JOINT BALL SNAP CLIP	70	0200-335	6	SPRING,TAIPIPE
31	8040-396	1	NUT,HEX,NYLOCK,1/4-28 UNF,ZN	71	0200-332	1	TAILPIPE,W/MTG FLANGE
32	2030-313	1	UNIT SENDING ENGINE TEMP W/DUETSCH	72	0300-980	4	WASHER,1.447 x .406 x .125
33	0304-382	2	CAPSCREW,HH 1/4-20UNCx 8.0 GR8	73	0301-083	2	PROTECTOR,POST,BATTERY
34	0304-406	1	BRKT,HOLDOWN,BATTERY				
35	8040-366	2	NUT,HEX,NYLOCK,1/4-20 UNC,ZN				
36	2010-463	1	BATTERY				
37	0090-561	1	CAPSCREW M14-1.5 X 25MM				
38	2010-206	1	WLMT BRKT THROTTLE				
39	0403-641	1	CLEVIS				
40	0300-581	1	W/NUTS,U-BOLT,1/4-20				

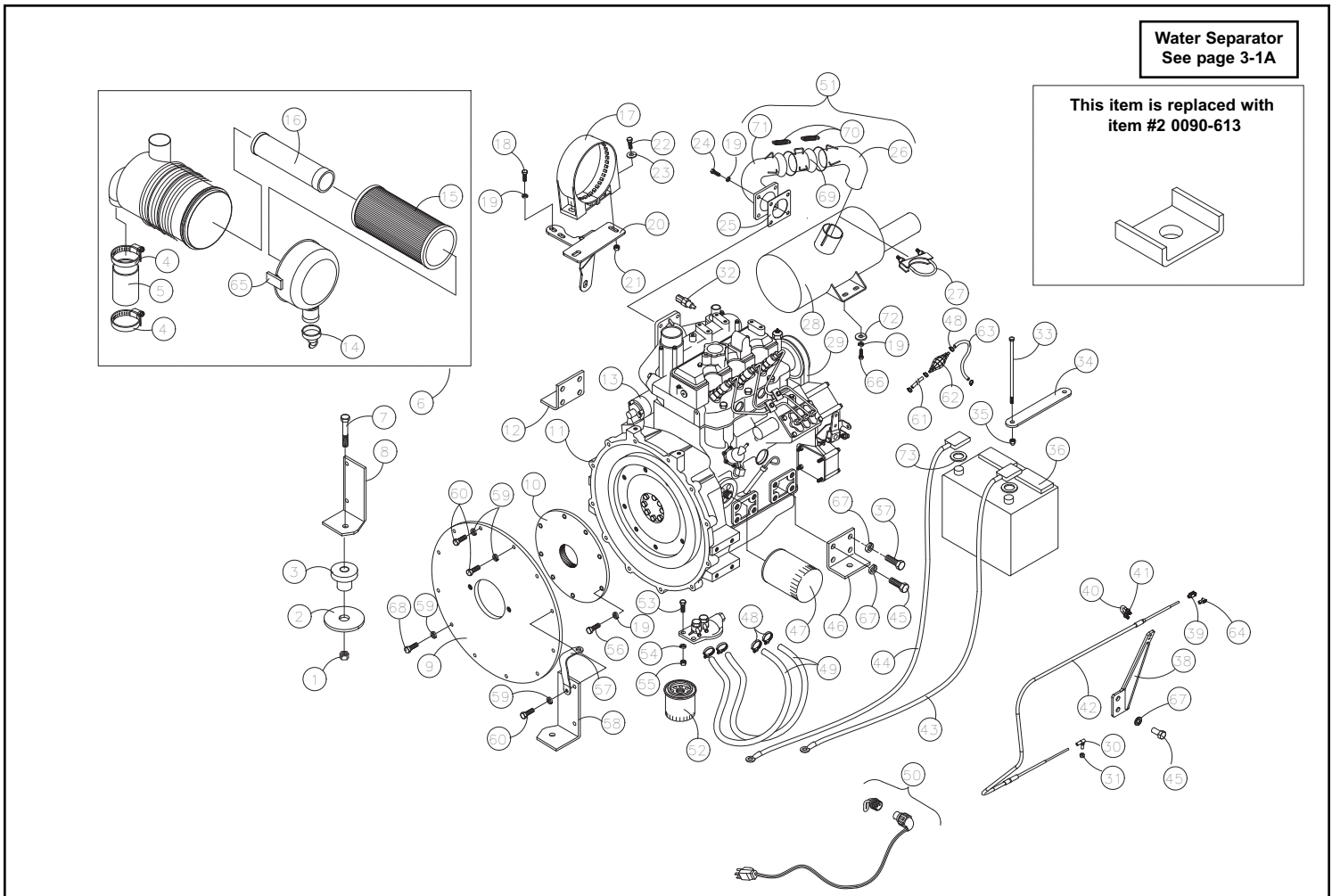

RADIATOR/OIL COOLER ASSEMBLY

RT-30 valid from - 06870
RO70T valid from - 00101

Charter 2

REF. NO.	PART NUMBER	QTY.	DESCRITION	REF. NO.	PART NUMBER	QTY.	DESCRITION
1	0305-011	1	CAPSCREW,HH,M6x1.0x20mm,ZN				
2	8102-040	4	CAPSCREW,HH,1/4-20 UNCx.75,GD8				
3	8051-212	4	WASHER,SPRING LOCK,1/4,ZN				
4	8050-222	8	WASHER,WROUGHT,1/4,STD,ZN				
5	0304-300	4	MNT,FAN GUARD				
6	2010-674	2	GUARD FAN				
7	0304-009	1	FAN,MULTI-WING				
8	0304-035	1	HOSE,RADIATOR, TOP				
9	0303-238	2	CLAMP,HOSE				
10	8040-366	4	NUT,1/4-20UNC,NYLOK				
11	2010-194	1	BRACKET LOCK				
12	0201-884	1	CAP,RADIATOR				
13	0304-285	1	GASKET,COOLER (LOWER)				
14	0304-444	1	HOSE,7/16 x 5/16 POLY,3FT				
15	0304-014	1	ASSY,COOLER & RESERVOIR				
16	0310-313	2	ADARTER,12MFFOR-12MB				
17	0304-032	1	SHROUD,FAN,RC-30 (BLACK)				
18	0304-036	1	HOSE,RADIATOR,BOTTOM				
19	2010-831	1	HOSE, -12, 250 PSI, 12FFORX45				
20	2010-484	1	HOSE -8 4000PSI 12FFORX90S 12FFORX 45"				
21	8040-366	5	NUT,HEX,NYLOCK,1/4-20 UNC,ZN				
22	8102-039	4	CAPSCREW,HH,1/4-20UNCx.625,GD8				
23	0302-371	1	PETCOCK,RADIATOR				
24	0304-536	1	WLMT,SHIELD				
25	0304-538	1	WLMT,SHIELD				
26	0304-690	2	TRIM,HOOD,17.5				
27	0304-537	1	WLMT, TOP				
28	0304-692	1	TRIM,HOOD,25				
29	8102-040	1	CAPSCREW,HH,1/4-20 UNCx.75,GD8 ZN				
30	8050-222	2	WASHER,WROUGHT,1/4,STD,ZN				
31	0090-123	1	TRIM				
32	0303-240	2	CLAMP, HOSE, #16 HI TORQUE				
33	8102-038	4	CAPSCREW,HH 1/4-20UNCx7/8 GRD8				

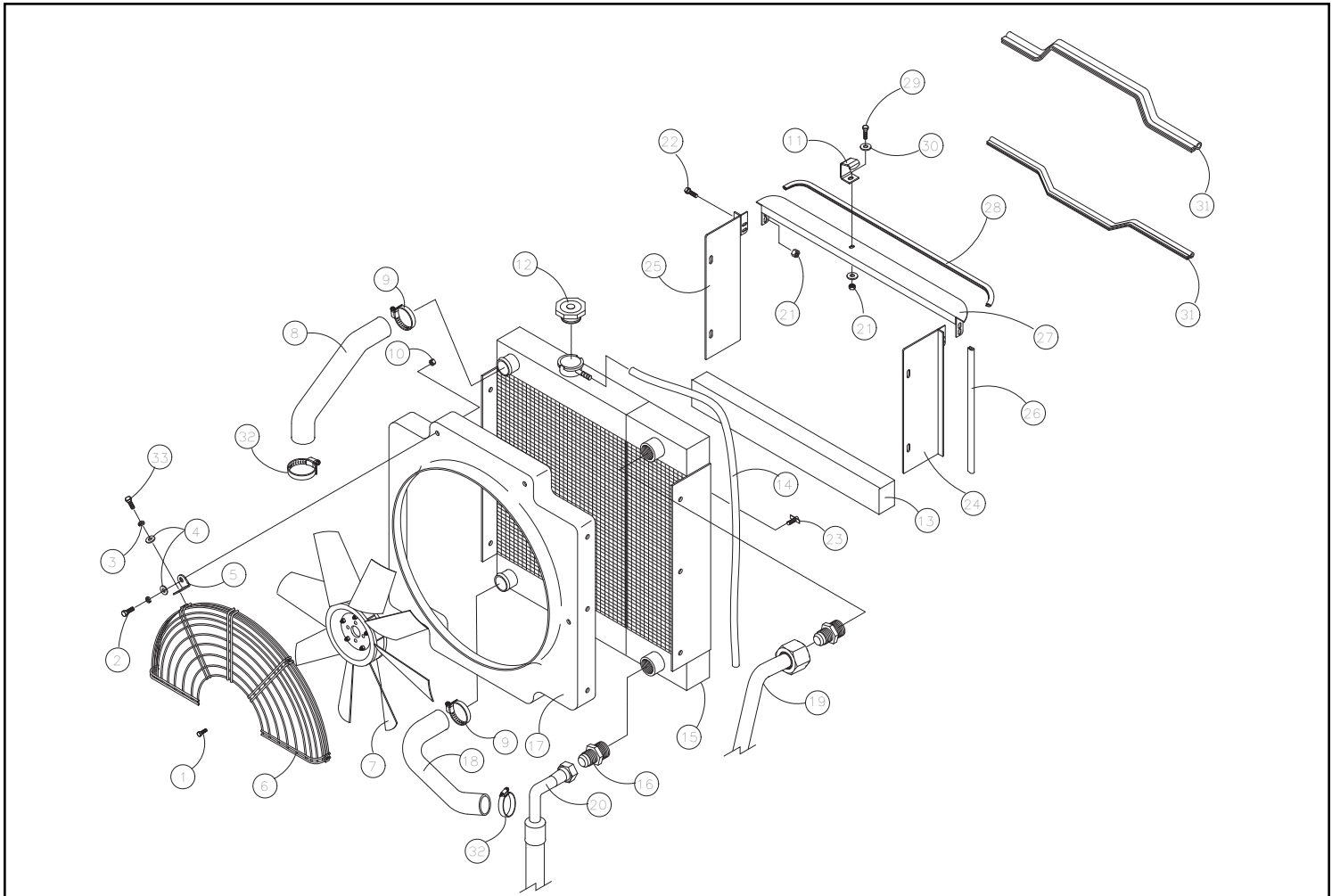

Charter 3

Hydraulic Components

3-1 Hydraulic Reservoir

RT-30 Serial # valid from - 06870. 3-1A

R070T Serial # valid from - 00101. 3-1A

3-2 Lift Arm Assembly

R070T Serial # 00101- 00374 3-2A

RT-30 Serial # valid from - 06870. 3-2B

R070T Serial # valid from - 00375. 3-2B

3-3 Lift Arm Tubes and Fittings

R070T Serial # 00101 - 00374 3-3A

RT-30 Serial # valid from - 06870. 3-3B

R070T Serial # valid from - 00375. 3-3B

3-4 Hydraulic Control

RT-30 Serial # valid from - 06870. 3-4A

R070T Serial # valid from - 00101. 3-4A

3-5 Drive / Auxilliary Pump Assembly

RT-30 Serial # valid from - 06870. 3-5A

R070T Serial # valid from - 00101. 3-5A

- * **This manual covers illustrations and parts lists for U.S, Australian, and New Zealand machines, and is updated on a regular basis. Always refer to the current online version to ensure you have the most up to date information prior to ordering parts.**

NOTE: Ordering parts that are painted requires a specific part number format. Please refer to page II of this manual for paint code and ordering information.

HYDRAULIC RESERVOIR ASSEMBLY

RT-30 valid from - 06870
RO70T valid from - 00101

Charter 3

REF. NO.	PART NUMBER	QTY.	DESCRIRTION	REF. NO.	PART NUMBER	QTY.	DESCRIRTION
1	0200-276	1	STRAINER,SUCTION,STEEL				
2	0304-450	1	VALVE,RELIEF,RES.				
3	2030-450	1	HYDRAULIC CAP				
4	0304-452	1	ASSY,COVER,ACCESS				
5	0200-203	1	ASSY,FILTER,HYD,4-BOLT				
6	0200-204	1	ELEMENT,FILTER,MP				
7	0304-642	1	GAUGE,SIGHT 5"				
8	0307-879	1	SWITCH,TEMP,OIL,225° F				
9	8102-134	1	CAPSCREW,HH,5/16-18UNCx1.25GD8				
10	8102-132	3	CAPSCREW,HH,5/16-18UNCx1.0 GD8				
11	8040-426	4	NUT,HEX,NYLOCK,5/16-18 UNC,ZN				
12	8050-262	4	WASHER,WROUGHT,5/16,STD,ZN				
13	2010-191	1	RESERVOIR HYDRAULIC RT30				
14	0304-384	2	CLAMP,HOSE # 16				
15	0304-442	1	HOSE,RES.				
16	0200-325	3	O-RING,FILTER CAP				
17	0090-232	2	ADARTER TEE				
18	0200-221	1	GASKET,COVER,ACCESS				
19	8104-132	4	CAPSCREW,HH 5/16-24UNFx 1 GD 8				
20	0200-338	1	ASSY,FILTER,WATER				
21	0200-617	1	SCREEN WATER FILTER ASSY				
22	8051-242	1	WASHER,SPRING LOCK,5/16,ZN				
23	8102-137	1	CAPSCREW,HH,5/16-18UNCx2.00				
24	0304-834	1	HOSE,LINE,FUEL,9"				
25	0300-732	2	CLAMP,HOSE #4				
26	2051-143	1	CAPSCREW,HH,M6-1x25				
27	8051-242	4	WASHER,SPRING LOCK,5/16,ZN				

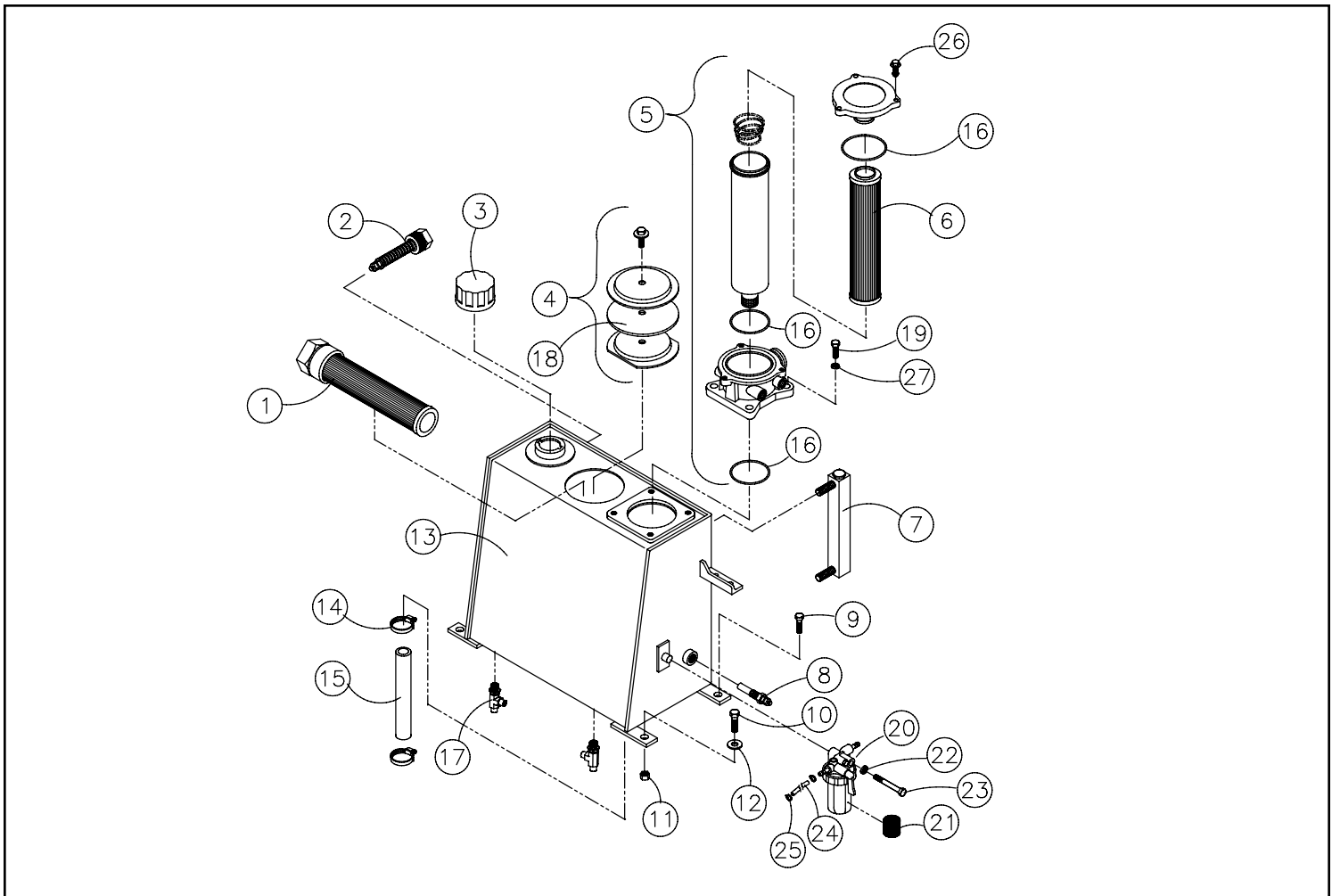

LIFT ARM ASSEMBLY

RO70T 00101 - 00374

Charter 3

REF. NO.	PART NUMBER	QTY.	DESCRIPTION	REF. NO.	PART NUMBER	QTY.	DESCRIPTION
1	2010-300	1	WLMT LOADER				
2	2010-832	2	CYLINDER BOOM				
3	2010-828	1	CYLINDER TILT LH				
4	2010-827	1	CYLINDER TILT RH				
5	2045-495	2	HOSE,6M4K,38.5"				
6	2010-430	2	HOSE -6 4000PSI 06FFOR 06FFOR 21.5"				
7	2010-272	4	BUSHING, LOADER, TOWER				
8	2010-147	4	WLMT PIN BIG				
9	0300-946	4	FITTING,GREASE,1/8 NRT				
10	0314-269	8	NUT,FLANGE,TOPLK,3/8-16UNC,GDG,ZN				
11	8011-222	4	BOLT,CARRIAGE,3/8-16 UNCx1.0,Z				
12	0090-382	2	ZERK 1/4-28 45 DEGREE LONG				
13	2010-554	8	BUSHING,LIFT ARM/TILT CYLINDER				
14	0310-567	8	ADARTER,8MFFOR-6MB				
15	2010-285	2	PIN LOADER WLMT				
16	8011-222	4	BOLT,CARRIAGE,3/8-16 UNCx1.0,ZN				
17	2030-328	2	WLMT PIN BUCKET				
18	0300-607	4	ZERK,GREASE,1/4-28 1103K21				
19	8102-219	2	CAPSCREW,HH 3/8-16x 1/2 GD 8				
20	8051-272	2	WASHER,SPRING LOCK,3/8,ZN				
21	2010-278	2	PIN QA WLMT				
22	2010-273	4	BUSHING, LOADER, QA				
23	2010-689	1	HARNESS AUX PWR ACT				
24	0201-770	1	CAP,W/CHAIN 82-00840				
25	0201-771	1	HARNESS,ELEC,AUX,RC100/85/60				
26	0090-562	4	PLUG				

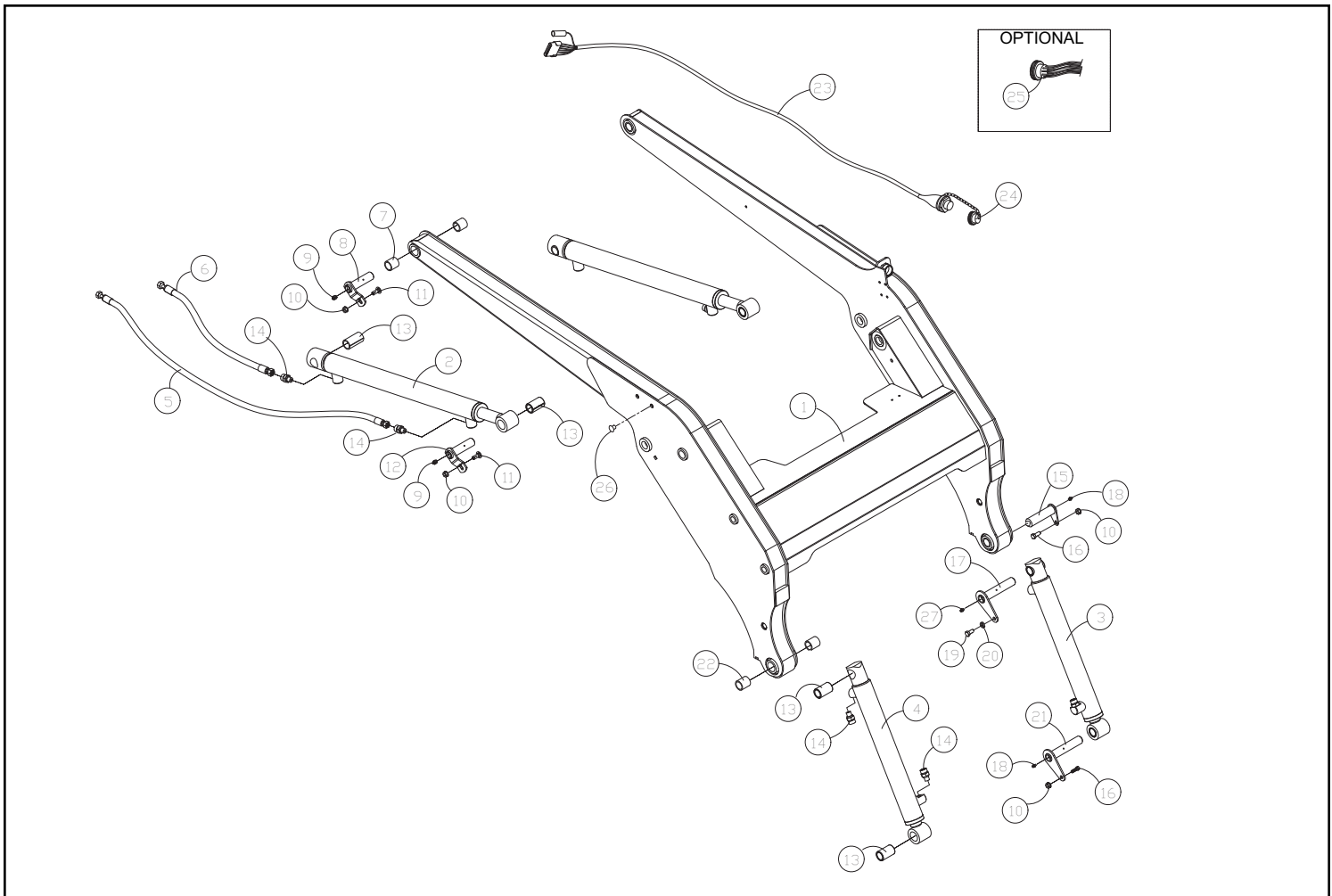

LIFT ARM ASSEMBLY

RT-30 valid from - 06870
RO70T valid from - 00375

Charter 3

REF. NO.	PART NUMBER	QTY.	DESCRIPTION	REF. NO.	PART NUMBER	QTY.	DESCRIPTION
1	2010-300	1	WLMT LOADER				
2	2010-832	2	CYLINDER BOOM				
3	2010-828	1	CYLINDER TILT LH				
4	2010-827	1	CYLINDER TILT RH				
5	2045-495	2	HOSE,6M4K,38.5"				
6	2010-430	2	HOSE -6 4000PSI 06FFOR 06FFOR 21.5"				
7	2010-272	4	BUSHING, LOADER, TOWER				
8	2010-147	4	WLMT PIN BIG				
9	0300-946	4	FITTING,GREASE,1/8 NRT				
10	0314-269	8	NUT,FLANGE,TOPLK,3/8-16UNC,GDG,ZN				
11	8011-222	4	BOLT,CARRIAGE,3/8-16 UNCx1.0,Z				
12	0090-382	2	ZERK 1/4-28 45 DEGREE LONG				
13	2010-554	8	BUSHING,LIFT ARM/TILT CYLINDER				
14	0310-329	4	ADAPTER,6MFFOR-6MB				
15	2010-285	2	PIN LOADER WLMT				
16	8011-222	4	BOLT,CARRIAGE,3/8-16 UNCx1.0,ZN				
17	2030-328	2	WLMT PIN BUCKET				
18	0300-607	4	ZERK,GREASE,1/4-28 1103K21				
19	8102-219	2	CAPSCREW,HH 3/8-16x 1/2 GD 8				
20	8051-272	2	WASHER,SPRING LOCK,3/8,ZN				
21	2010-278	2	PIN QA WLMT				
22	2010-273	4	BUSHING, LOADER, QA				
23	2010-689	1	HARNESS AUX PWR ACT				
24	0201-770	1	CAP,W/CHAIN 82-00840				
25	0201-771	1	HARNESS,ELEC,AUX,RC100/85/60				
26	0090-562	4	PLUG				
27	0315-011	4	ADAPTER, MORB, COUPLING: 3/8", CONNECTION				

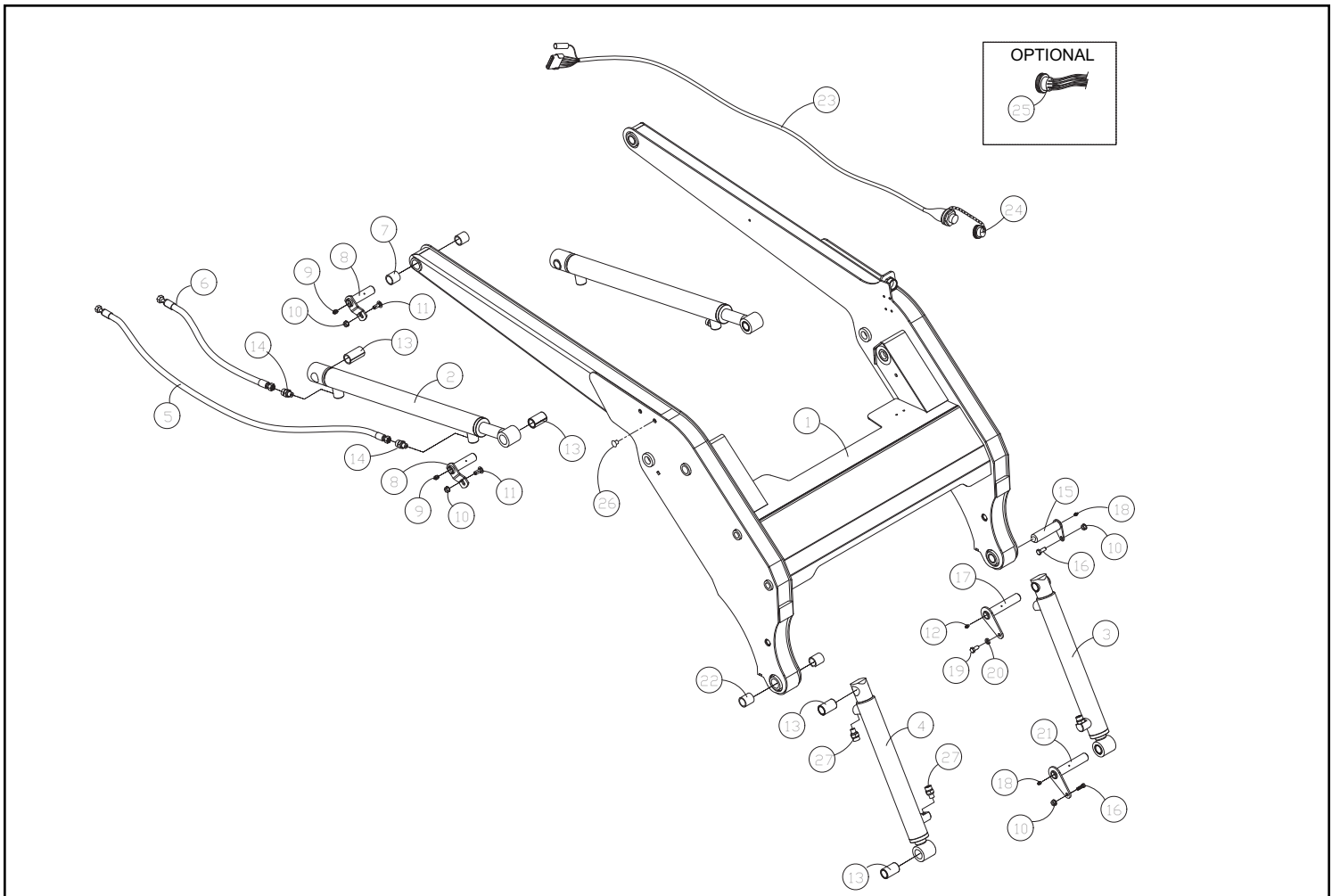

LIFT ARM TUBES AND FITTINGS

RO70T 00101 - 00374

Charter 3

REF. NO.	PART NUMBER	QTY.	DESCRIPTION	REF. NO.	PART NUMBER	QTY.	DESCRIPTION
1	0201-488	2	HOSE,8M4K-8FFORX-8FFORX-23.5"				
2	2010-565	2	HOSE -8 4000PSI 8FFORX 8FFORX 15				
3	2010-423	1	ASSY TUBE LOADER TILT BTM A				
4	2010-422	1	ASSY TUBE LOADER TILT TOP				
5	2010-409	1	ASSY TUBE CASE DRAIN				
6	2010-410	1	ASSY TUBE AUX TOP				
7	2010-411	1	ASSY TUBE AUX BOTTOM				
8	8102-135	3	CAPSCREW,HH,5/16-18X1.50ZN,GD8				
9	0310-583	2	CLAMP,SET,T2050-PP T2050-PP				
10	0304-340	1	CLAMP,OIL LINE,LOADER RC-30 48357 H				
11	0310-329	1	ADAPTER,6MFFOR-6MB				
12	0201-658	2	ADAPTER,10MFFOR-8MB-SV				
13	0304-614	1	VALVE,RELIEF,LOW FLOW,AUX				
14	0304-876	1	MANIFOLD,AUX,HYD				
15	0304-188	1	PLUG,6 ORING,HH				
16	0310-077	1	COUPLER,QUICK,FF,MALE				
17	0310-076	1	COUPLER,QUICK,FF				
18	0200-296	2	ADAPTER,O-RING HEX NIPPLE,10-8				
19	8051-212	4	WASHER,SPRING LOCK,1/4,ZN				
20	8102-049	4	CAPSCREW,HH 1/4-20 x 2.50 GD8				
21	0201-402	2	CLAMP,SET,2050-PP				
22	0201-224	2	COVER,CLAMP,COP-2				
23	8102-044	4	CAPSCREW,HH,1/4-20UNCx1.25,GD8,ZN				
24	0310-831	1	CLAMP, SET, T2062-PP BEHRINGER				
25	0310-584	3	PLATE,COVER TCP-T2 TCP-T2				

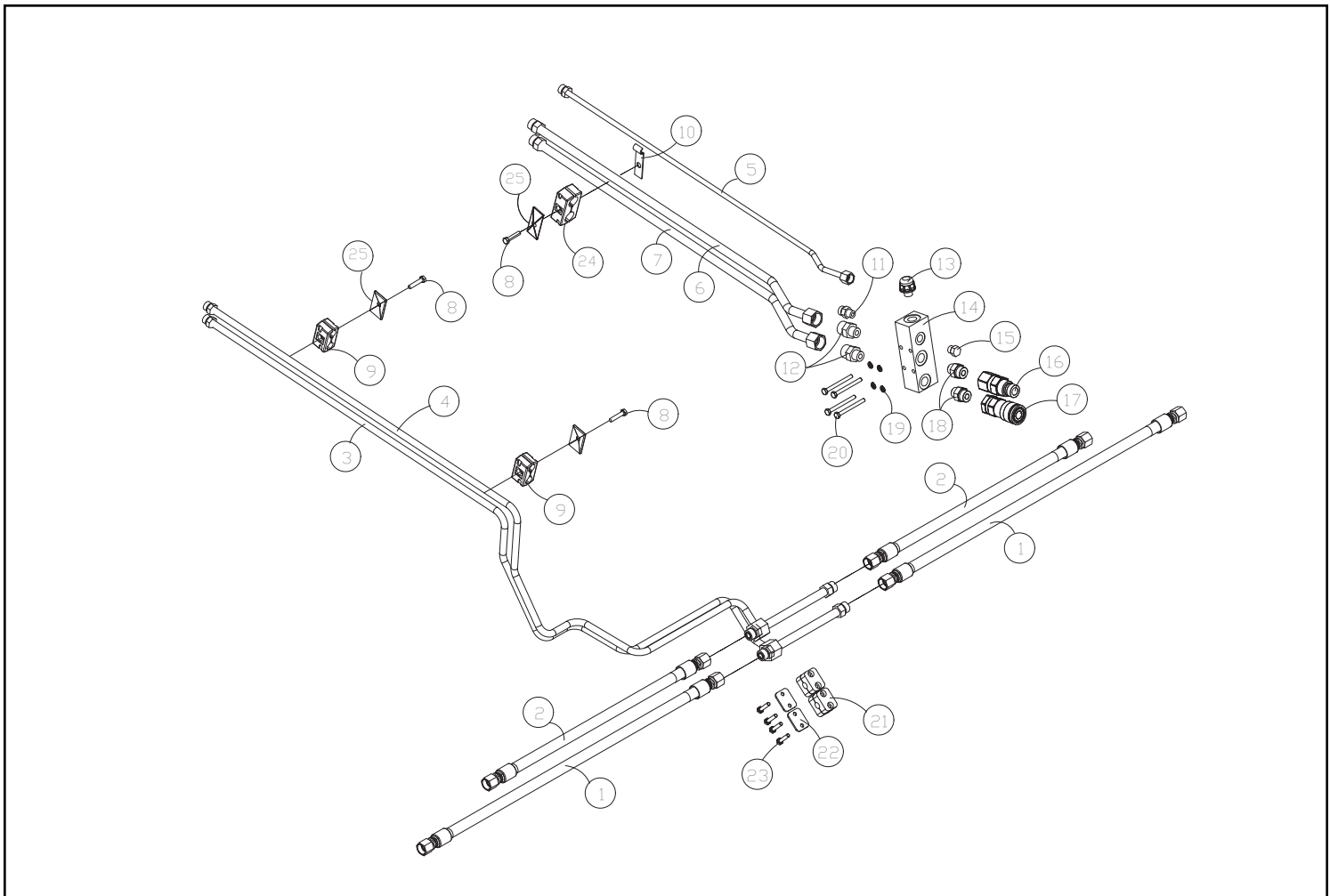

LIFT ARM TUBES AND FITTINGS

RT-30 valid from - 06870
RO70T valid from - 00375

Charter 3

REF. NO.	PART NUMBER	QTY.	DESCRIPTION	REF. NO.	PART NUMBER	QTY.	DESCRIPTION
1	2010-826	2	HOSE, -6, 4000 PSI, FFX-06-08-W				
2	2010-825	2	HOSE, -6, 4000 PSI, FFX-06-08-W, 0314-530, 15.89"				
3	2010-423	1	ASSY TUBE LOADER TILT BTM A				
4	2010-422	1	ASSY TUBE LOADER TILT TOP				
5	2010-409	1	ASSY TUBE CASE DRAIN				
6	2010-410	1	ASSY TUBE AUX TOP				
7	2010-411	1	ASSY TUBE AUX BOTTOM				
8	8102-135	3	CAPSCREW,HH,5/16-18X1.50ZN,GD8				
9	0310-583	2	CLAMP,SET,T2050-PP T2050-PP				
10	0304-340	1	CLAMP,OIL LINE,LOADER RC-30 48357 H				
11	0310-329	1	ADAPTER,6MFFOR-6MB				
12	0201-658	2	ADAPTER,10MFFOR-8MB-SV				
13	0304-614	1	VALVE,RELIEF,LOW FLOW,AUX				
14	0304-876	1	MANIFOLD,AUX,HYD				
15	0304-188	1	PLUG,6 ORING,HH				
16	0310-077	1	COUPLER,QUICK,FF,MALE				
17	0310-076	1	COUPLER,QUICK,FF				
18	0200-296	2	ADAPTER,O-RING HEX NIPPLE,10-8				
19	8051-212	4	WASHER,SPRING LOCK,1/4,ZN				
20	8102-049	4	CAPSCREW,HH 1/4-20 x 2.50 GD8				
21	0201-402	2	CLAMP,SET,2050-PP				
22	0201-224	2	COVER,CLAMP,COP-2				
23	8102-044	4	CAPSCREW,HH,1/4-20UNCx1.25,GD8,ZN				
24	0310-831	1	CLAMP, SET, T2062-PP BEHRINGER				
25	0310-584	3	PLATE,COVER TCP-T2 TCP-T2				

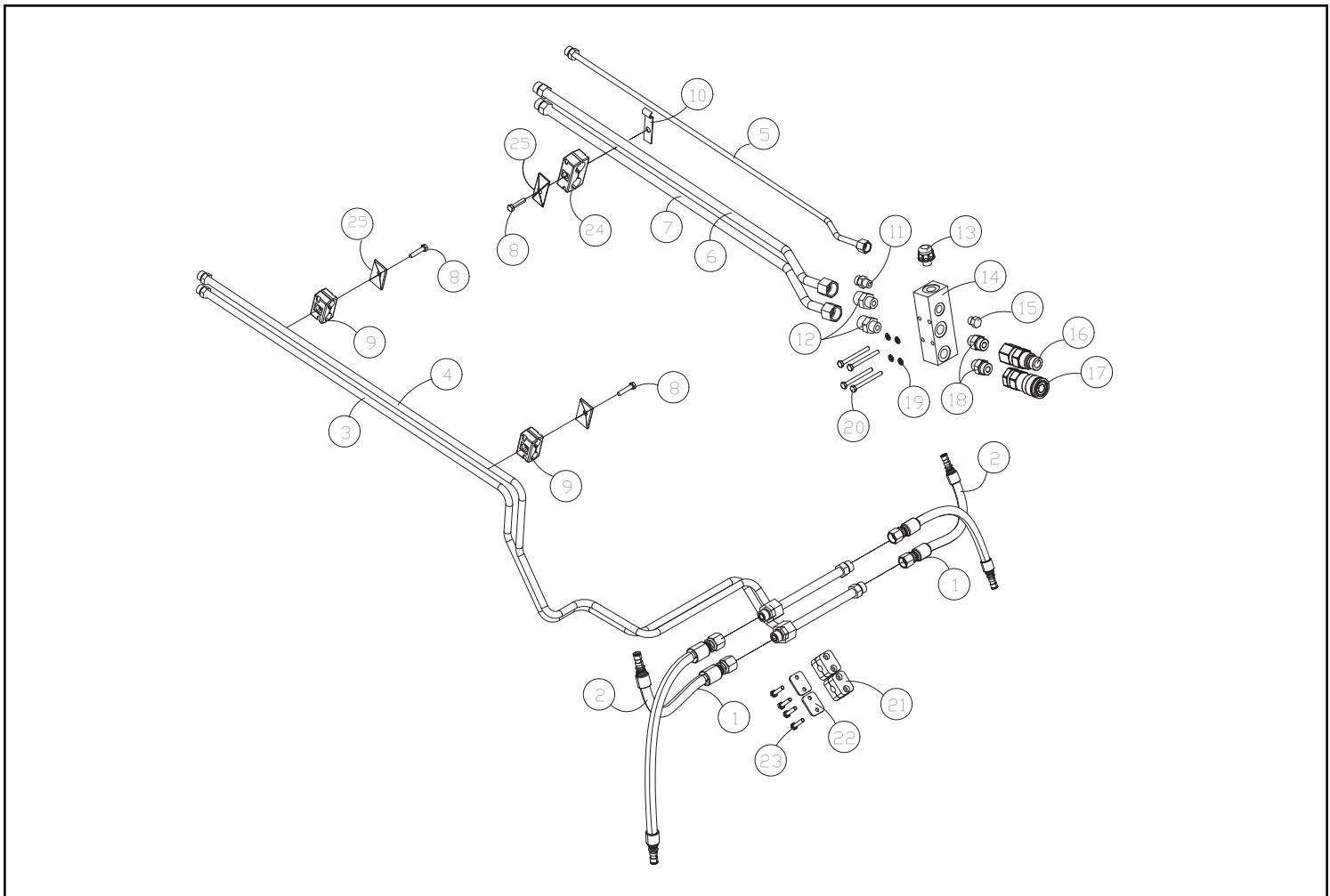

HYDRAULIC CONTROL ASSEMBLY

RT-30 valid from - 06870
RO70T valid from - 00101

Charter 3

REF. NO.	PART NUMBER	QTY.	DESCRIPTION	REF. NO.	PART NUMBER	QTY.	DESCRIPTION
1	2030-675	1	ASSY,JOYSTICK,LH	41	0201-668	1	ADAPTER,FS6801-10-10NW0
2	0307-882	2	TIE,CABLE,BLACK,18.1",W/STL INSERT BT-5L	42	0304-842	1	VALVE,ANTI-VOID 5475
3	0304-441	1	SWITCH,PRESSURE NASON	43	2010-470	1	HOSE -8 4000PSI 8FFORXL90 8-12FFORX 13.5
4	0201-309	13	ADAPTER,FS6400-04-06-0	44	0201-319	1	ADAPTER,FS6801-04-06-NW0
5	2010-708	1	HOSE, -4, 500 PSI, 4FFORX, 4FFORX90S, 49	45	0090-234	1	ADAPTER 8FFOR-12MB FS6400-08-12-O
6	2030-052	2	HOSE,4G1,4FFORX90S,4FFORX,47.5	46	2010-830	1	VALVE,LOADER
7	2010-488	2	HOSE -4 4000PSI 4FFORX 4FFORX90L 62"	47	2030-640	1	VALVE RELIEF 3000 PSI
8	2010-707	2	HOSE, -4, 500 PSI, 4FFORX, 4FFORX90S, 55	48	2010-419	1	ASSY TUBE BOOM BTM
9	2010-709	1	HOSE, -4, 500 PSI, 4FFORX, 4FFORX90S, 52	49	2010-734	4	ADAPTER ORIFICE .040" FS6400-04-06
10	2010-468	1	TUBE AUX BTM	50	0090-538	1	O-RING 116 BUNA-N 90 DURO
11	2010-692	1	PUMP TANDEM 17CC BONDIOLI & PAVESI	51	8102-225	2	CAPSCREW,HH,3/8-16 UNCx1.5,GD8,ZN
12	0201-311	9	ADAPTER,FS6400-04-04-0	52	8051-272	2	WASHER,SPRING LOCK,3/8,ZN
13	2030-036	1	HOSE,4G1,4FFORX90M,6FFORX,36.0	53	2013-436	1	BRACE PUMP
14	0310-329	1	ADAPTER,6MFFOR-6MB	54	0304-722	1	NUT,HEX,JAM,LOCKING,3/4-10UNC THIN
15	2010-486	1	HOSE -8 4000PSI 8FFORX 8FFORX 28	55	8050-436	1	WASHER,WROUGHT,3/4,STD,ZN
16	0201-309	2	ADAPTER,FS6400-04-06-0	56	2013-308	1	STUD PLUG
17	8005-498	2	CAPSCREW,SOC HH,1/4-20UNCx2.25	57	8040-426	2	NUT,HEX,NYLOCK,5/16-18 UNC,ZN
18	2010-638	1	PILOT GEN BLOCK #6 BRAKE PORTS	58	0310-583	2	CLAMP,SET,T2050-PP T2050-PP
19	8040-366	10	NUT,HEX,NYLOCK,1/4-20 UNC,ZN	59	0310-584	2	PLATE,COVER TCP-T2 TCP-T2
20	0314-043	1	COUPLING,PORT,TEST,MALE,#6SAE-M 6V3965	60	8102-137	2	CAPSCREW,HH,5/16-18UNCx2.0 GD8 ZN
21	0304-516	1	MAGNET,DETENT	61	8050-262	2	WASHER,WROUGHT,5/16,STD,ZN
22	0201-775	2	BOOT,JOYSTICK,RH				
23	0201-152	2	GRIP,CONTROL				
24	2030-661	1	ASSY,JOYSTICK,RH				
25	8102-040	8	CAPSCREW,HH,1/4-20 UNCx.75,GD8 ZN				
26	2010-485	1	HOSE -8 4000PSI 8FFORX 8FFORX 26				
27	0304-395	2	CLAMP,PILOT LINES				
28	2030-059	1	ASSY,LINE,CONTROL,DUMP,BUCKET				
29	2030-062	1	ASSY,LINE,CONTROL,UP,LOADER				
30	2030-067	1	ASSY,LINE,CONTROL,TOP,AUX				
31	2030-057	1	ASSY,LINE,CONTROL,DOWN,LOADER				
32	2030-055	1	ASSY,LINE,CONTROL,CURL,BUCKET				
33	2030-064	1	ASSY,LINE,CONTROL,BOTTOM,AUX.				
34	2010-469	1	TUBE AUX TOP				
35	2010-418	1	ASSY TUBE BOOM TOP				
36	2010-405	1	ASSY TUBE TILT BTM				
37	2010-404	1	ASSY TUBE TILT TOP				
38	0310-330	2	ADAPTER,10MFFOR-8MB-90				
39	0310-345	2	ADAPTER,8MFFOR--8MB				
40	0310-394	2	TUBE,HYD,FILTER,LF				

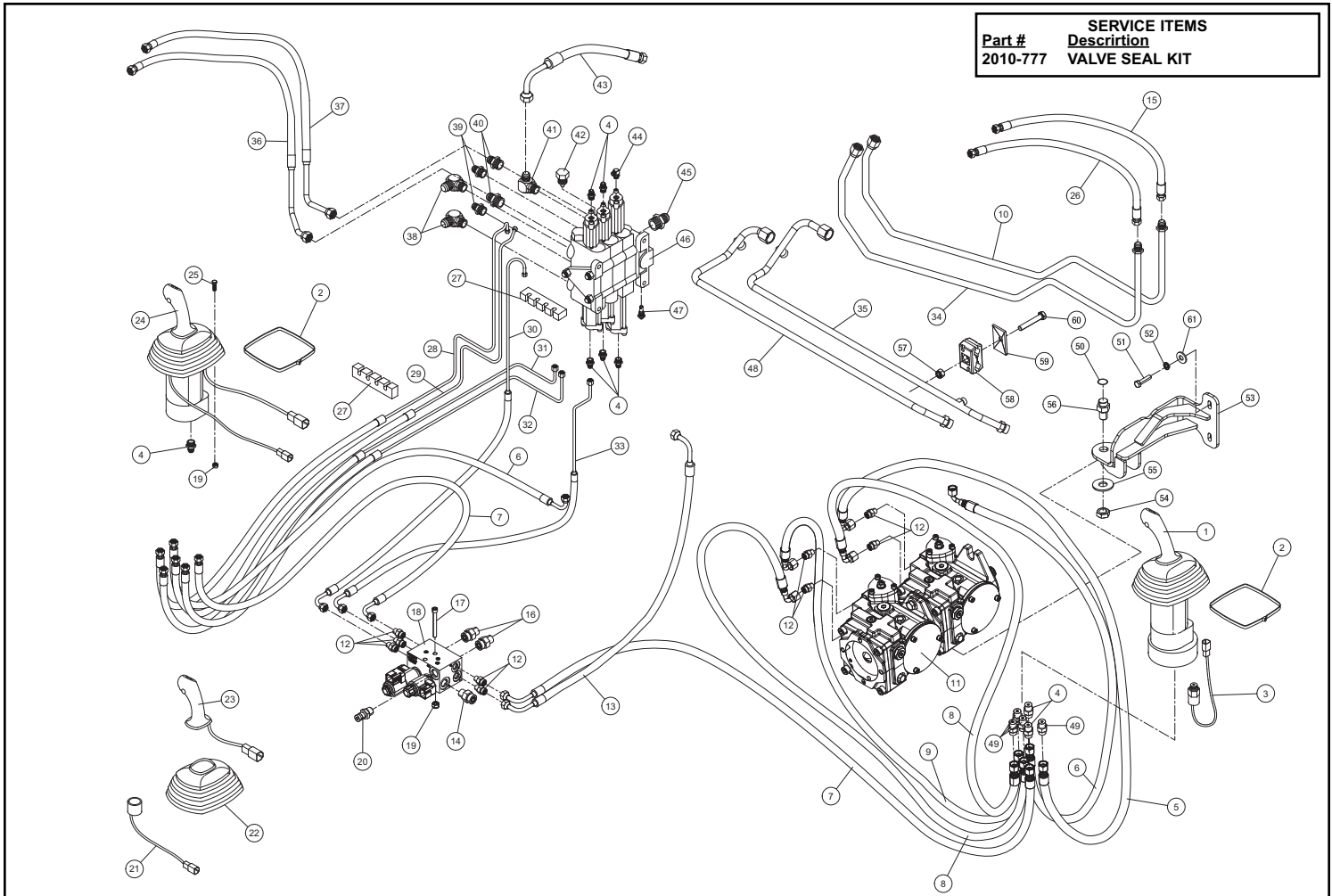

DRIVE/AUXILIARY PUMP ASSEMBLY

RT-30 valid from - 06870
RO70T valid from - 00101

Charter 3

REF. NO.	PART NUMBER	QTY.	DESCRIPTION	REF. NO.	PART NUMBER	QTY.	DESCRIPTION
1	7000-625	3	COIL PILOT GEN BLOCK	41	2010-700	1	HOSE, -10, 6000 PSI, 10FFORX, 10FFORX90S
2	2010-737	1	2-POS.3-WAY VALVE W/COIL	42	2010-829	1	HOSE, -8, 4000 PSI, 8FFORX90M, 8FFORX90S, 39"
3	2010-736	1	3-POS.4-WAY VALVE W/COILS	43	0304-384	2	CLAMP,HOSE # 16
4	2010-638	1	PILOT GEN BLOCK #6 BRAKE PORTS	44	8040-426	2	NUT,HEX,NYLOCK,5/16-18 UNC,ZN
5	2010-704	2	HOSE, -6, 500 PSI, 6FFORX, 6FFORX110, 27	45	8050-222	2	WASHER,WROUGHT,1/4,STD,ZN
6	2075-272	2	CLAMP,SET,T4100-PP	46	0310-584	2	PLATE,COVER TCP-T2 TCP-T2
7	0310-831	2	CLAMP, SET, T2062-PP BEHRINGER	47	0090-443	2	ROD THRD 5/16"-18 6"
8	2010-701	1	HOSE, -10, 6000 PSI, 10FFORX, 10FFORX110				
9	2010-702	1	HOSE, -10, 6000 PSI, 10FFORX, 10FFORX110				
10	2010-705	1	HOSE, -6, 500 PSI, 6FFORX, 6FFORX110, 38				
11	0315-010	10	ADARTER,10MFFOR-10MB				
12	2045-600	2	ADARTER FS6802-04-06-NWO				
13	0310-329	2	ADARTER,6MFFOR-6MB				
14	2010-571	2	MOTOR HYD MCR3F				
15	0200-282	10	NUT,FLANGE,M14x1.5				
16	0210-001	10	STUD,WHEEL,M14x1.5 174862				
17	0201-668	1	ADARTER,FS6801-10-10NWO				
18	0300-687	2	CLAMP,HOSE,1.5,#24 H24				
19	2010-757	1	TUBE SUCTION				
20	2010-761	1	HOSE INTAKE CHARGE				
21	2010-760	1	HOSE -6 500 PSI 6FFOX90S , 6FFOX90L				
22	2010-758	1	TUBE CHARGE				
23	0310-323	2	ADARTER,16MFFOR-12MB				
24	0304-133	2	CAPSCREW,12RT,1/2-13UNC X 1.5"				
25	0090-148	2	WASHER SPRING LOCK 1/2 ZN				
26	0304-404	2	WASHER,FLAT,1.125 OD x .5 ID x 1/4,ZN				
27	2013-253	1	DOUBLE PISTON PUMP BONDIOLI				
28	0310-934	2	ADARTER,8MFFOR-10MB,8-10 F5OLO-S				
29	2010-695	1	TUBE MANIFOLD CASE DRAIN				
30	2010-730	1	HOSE,RES.				
31	0303-095	2	CAPSCREW M10 x 1.5 x 25 HCS 10.9OZ				
32	0301-781	2	WASHER,SPLIT LOCK,10mm,ZN				
33	0304-188	1	PLUG,6 ORING,HH				
34	2013-254	1	DOUBLE GEAR PUMP BONDIOLI				
35	0090-228	1	ADARTER 8FFORX-10MB-90 NWO FS6801-08-10-				
36	0700-124	10	NUT,TOPLock,1/2-13UNC,ZN,GD8				
37	2035-597	10	WASHER WROUGHT .531 x .886 x 0118 HARD Z				
38	8102-406	10	CAPSCREW,HH,1/2-13UNCx1.75,GD8				
39	2010-703	1	HOSE, -6, 500 PSI, 6FFORX, 6FFORX110, 35				
40	2010-699	1	HOSE, -10, 6000 PSI, 10FFORX, 10FFORX90S				

If your machine has a bondioli brand drive pump (item 27), but item 34 is a single pump with 1 inlet and 1 outlet port (current has 2 of each), your configuration is no longer available. If pump replacement is required, you must purchase the following update kit.

PART # DESCRIPTION
0404-358 Kit, RT30 Pump Field Update

P/N: 2013-250 Pump Assembly
(includes items 27, 34)

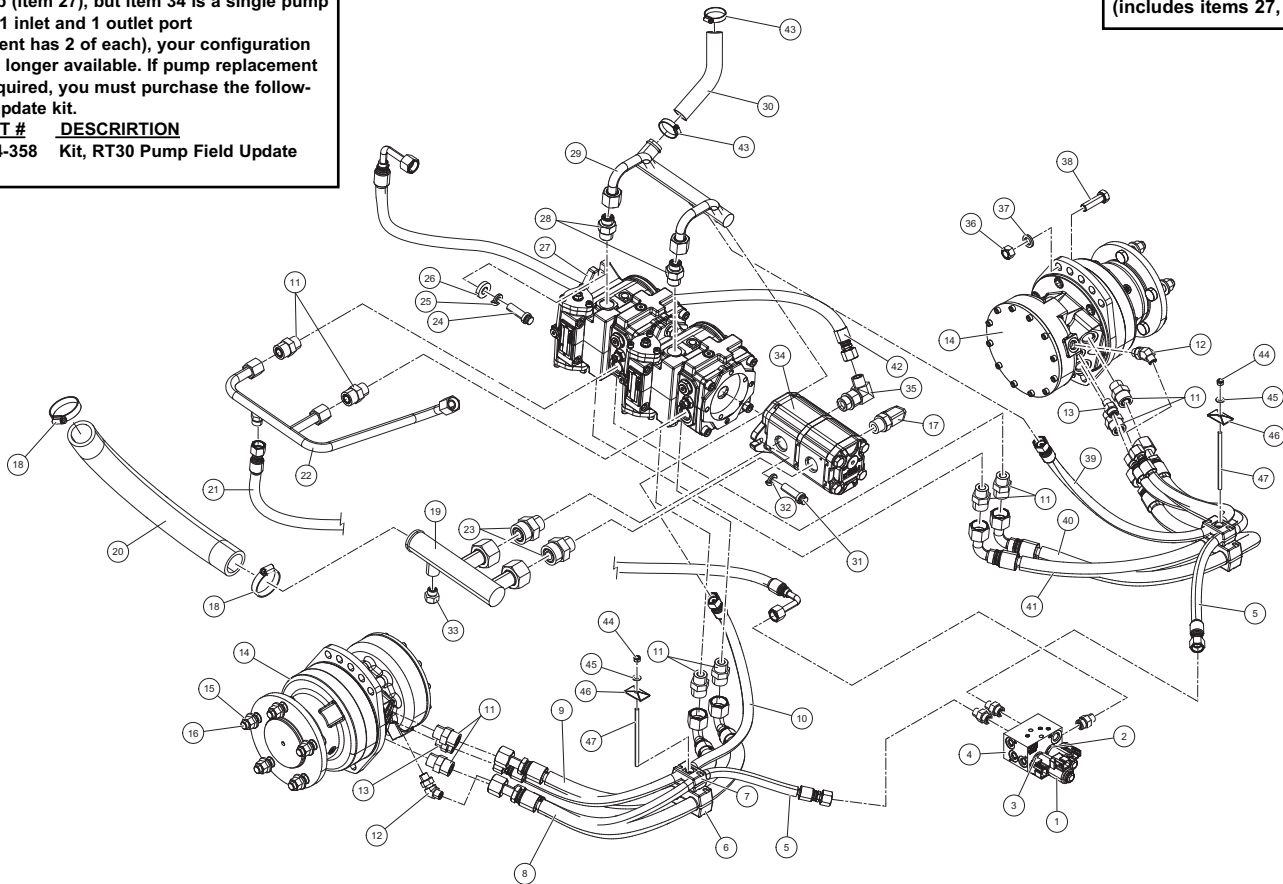

Charter 4

Electrical

4-1 Light Bar Assembly

RT-30 Serial # valid from - 06870. 4-1A

R070T Serial # valid from - 00101. 4-1A

RT-30 (Australia/ New Zealand)

Serial # valid from - 06870. 4-1B

4-2 Fuse Panel

RT-30 Serial # valid from - 06870. 4-2A

R070T Serial # valid from - 00101. 4-2A

- * **This manual covers illustrations and parts lists for U.S, Australian, and New Zealand machines, and is updated on a regular basis. Always refer to the current online version to ensure you have the most up to date information prior to ordering parts.**

NOTE: Ordering parts that are painted requires a specific part number format. Please refer to page II of this manual for paint code and ordering information.

LIGHT BAR ASSEMBLY

RT-30 valid from - 06870
RO70T valid from - 00101

Charter 4

REF. NO.	PART NUMBER	QTY.	DESCRIRTION	REF. NO.	PART NUMBER	QTY.	DESCRIRTION
1	2045-755	4	KIT LIGHTS 35W W/ HARNESS				
2	2045-756	4	LIGHT 35W W/BEZEL				
3	0201-595	2	HARNESS,LIGHT,DOUBLE				
4	2010-159	1	DECAL DASH PANEL				
5	2030-241	1	CONSOLE MACHINED				
6	2030-245	1	LIGHT DOME				
7	0304-411	1	PLUG, HOLE, 3/4", PLASTIC				
8	0310-128	1	SWITCH,HEATER				
9	8102-142	2	CAPSCREW,HH,5/16-18x3.25,GD8				
10	0303-099	2	WASHER,STAR,3/8,				
11	8050-262	4	WASHER,WROUGHT,5/16,STD,ZN				
12	2030-397	1	PLATE MOUNT HOUR METER				
13	2030-272	1	PLATE BACKING GAUGES				
14	2045-502	1	METER HOUR				
15	0304-028	1	SWITCH,IGNITION,RC				
16	0310-138	6	PLUG				
17	0310-126	1	SWITCH,LIGHT				
18	0310-136	4	FRAME,END				
19	0200-252	2	SWITCH,3 POSITION,LOCKING				
20	2045-432	1	KEY IGNITION				
21	2045-792	1	COVER KEY IGNITION				
22	0304-551	1	RING,KEY				
23	8008-217	2	SCREW,MACH#6-32x0.5,PH,PAN				
24	2030-244	1	GAUGE WARNING INDICATION				
25	4010-014	1	GAUGE FUEL				
26	2030-303	2	PLUG FINISHING 2"				
27	0310-137	4	FRAME,MID				
28	0310-133	1	SWITCH,BEACON				
29	0304-123	1	SWITCH,ON/OFF,WIPER				
30	0201-952	2	SPACER .625OD, .38 ID x 2 5/16"				
31	0090-105	2	NUT PUSH 5/16"				
32	2030-431	1	DECAL IGNITION				

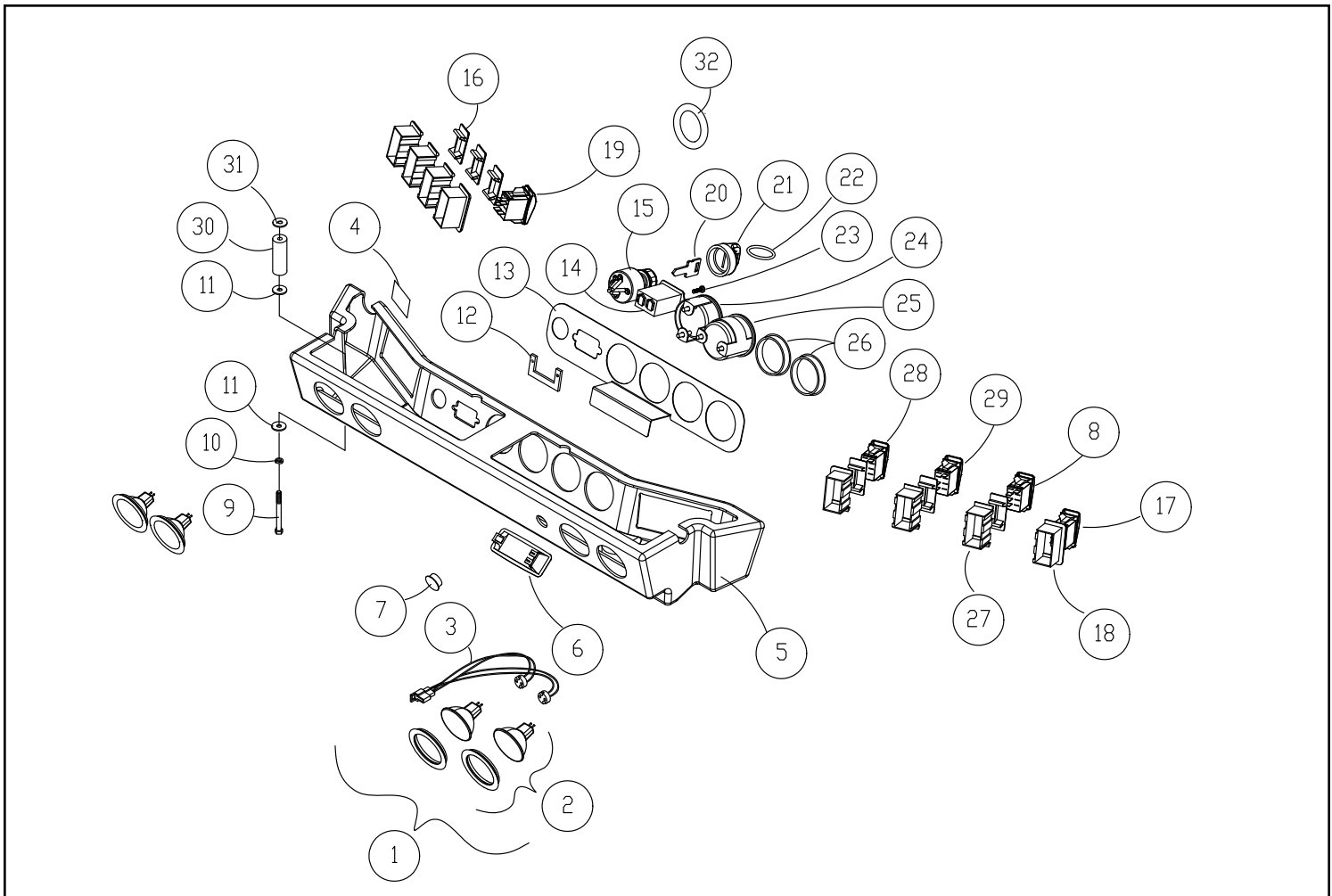

REF. NO.	PART NUMBER	QTY.	DESCRIPTION	REF. NO.	PART NUMBER	QTY.	DESCRIPTION
1	0090-105	2	NUT PUSH 5/16"				
2	0310-126	1	SWITCH 2 POSITION WORKLIGHT				
3	0310-138	6	PLUG				
4	0310-136	4	FRAME,END				
5	0310-137	4	FRAME,MID				
6	4030-025	2	SPACER LIGHTBAR				
7	4010-014	1	GAUGE FUEL				
8	8050-262	4	WASHER,WROUGHT,5/16,STD,ZN				
9	0303-099	2	WASHER,STAR,3/8,				
10	0310-133	1	SWITCH,BEACON				
11	8102-142	2	CAPSCREW,HH,5/16-18x3.25,GD8				
12	2030-303	2	PLUG FINISHING 2"				
13	4030-009	2	LIGHT SPEAKER				
14	2030-245	1	LIGHT DOME				
15	2030-397	1	PLATE MOUNT HOUR METER				
16	8008-217	2	SCREW,MACH#6-32x0.5,PH,PAN				
17	2045-502	1	METER HOUR				
18	2030-244	1	GAUGE WARNING INDICATION (/HARDWARE)				
19	2045-792	1	COVER KEY IGNITION				
20	0304-028	1	SWITCH,IGNITION,RC				
21	0304-551	1	RING,KEY				
22	2045-432	1	KEY IGNITION				
23	0200-252	1	SWITCH,3 POSITION,LOCKING				
24	2045-413	1	SWITCH LOCKING PARK				
25	4030-005	1	LIGHTBAR				

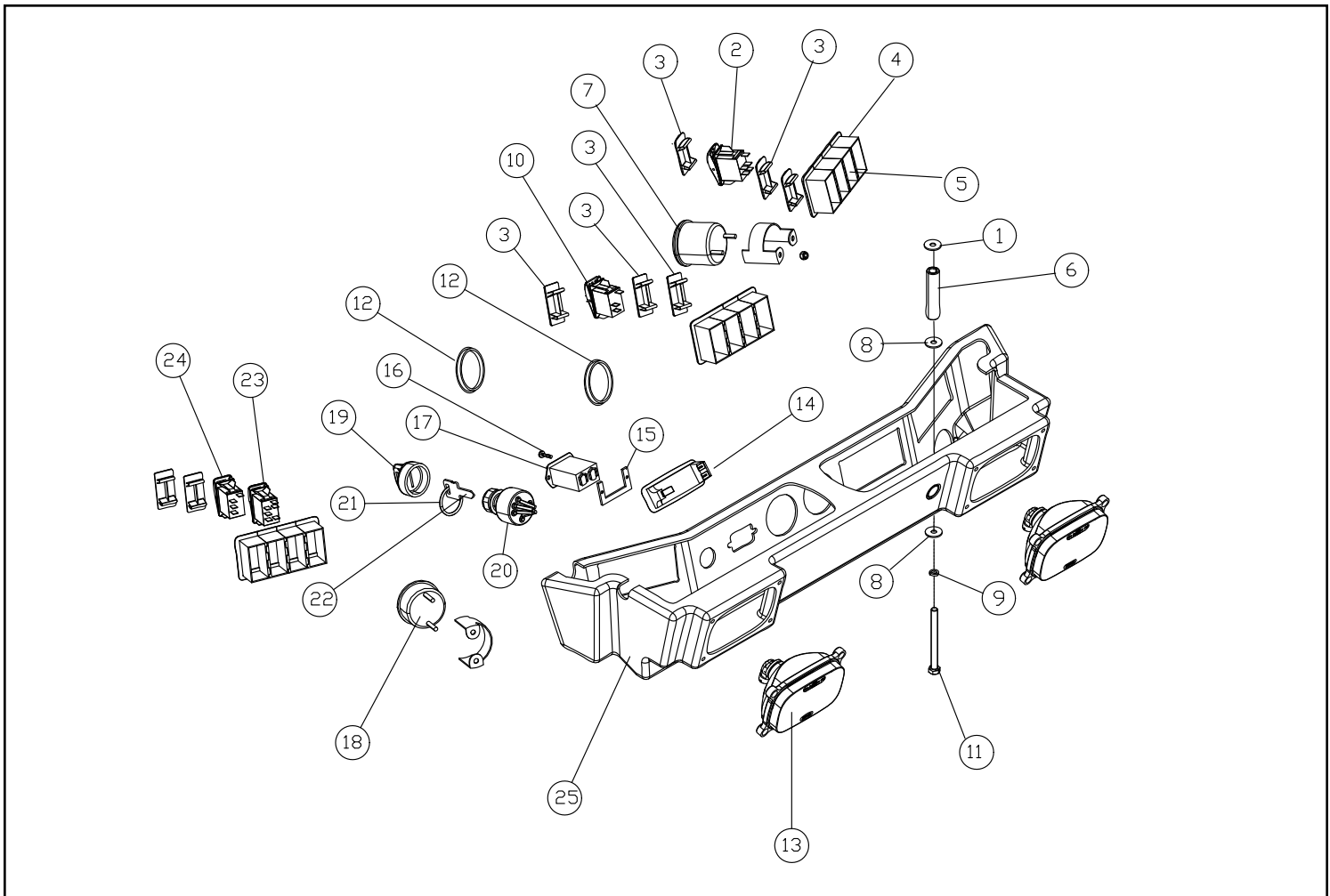

FUSE PANEL ASSEMBLY

RT-30 valid from - 06870
RO70T valid from - 00101

Charter 4

REF. NO.	PART NUMBER	QTY.	DESCRIRTION	REF. NO.	PART NUMBER	QTY.	DESCRIRTION
1	-----	1	HARNESS MAIN --SEE HARNESSES ON PAGE III				
2	0310-807	2	RELAY,MINI, 35 AMP				
3	0310-804	1	FUSE,MAXI, 60 AMP				
4	0304-519	6	RELAY,PLUG,GLOW				
5	0310-800	2	FUSE,MAXI,20 AMP				
6	0310-803	2	FUSE,MAXI, 50 AMP				
7	0310-802	2	FUSE,MAXI, 40 AMP				
8	0310-794	6	FUSE,MINI, 5 AMP				
9	0310-795	7	FUSE,MINI,10 AMP				
10	0310-796	2	FUSE,MINI,15 AMP				
11	0310-806	4	RELAY,MICRO, 20 AMP				
12	0310-811	1	DIODE, 3 AMP				
13	0200-510	1	RESISTOR,330HM/3WATT,OHMITE43F				
14	2010-089	1	COVER,PANEL,FUSE,W ITH DECALS				
15	0310-797	1	FUSE,MINI,20 AMP				

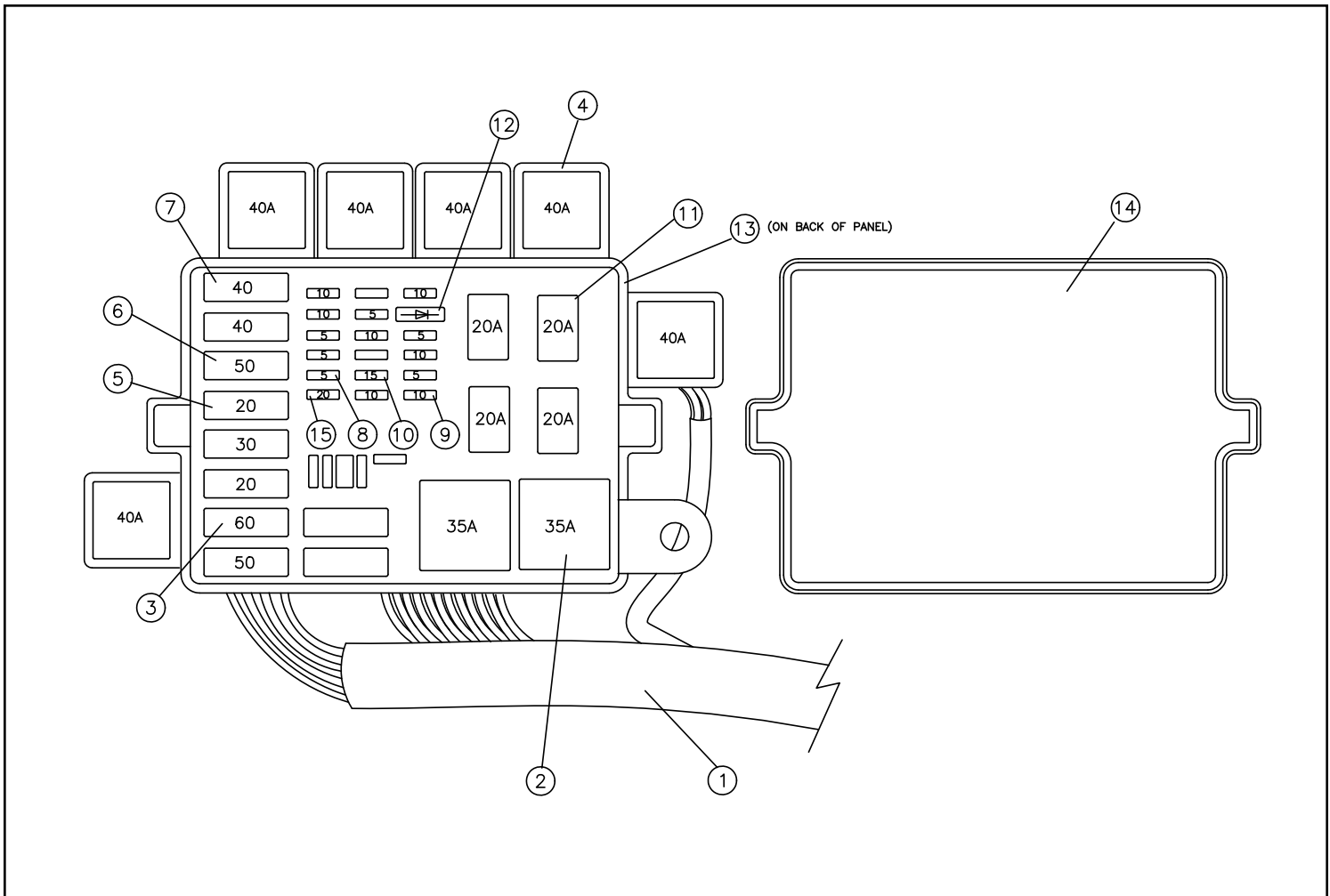

Charter 5

Undercarriage

5-1 Torsion Axle

RT-30 Serial # valid from - 06870.5-1A

R070T Serial # valid from - 00101.5-1A

5-2 Undercarriage Assembly RT

RT-30 Serial # valid from - 06870.5-2A

R070T Serial # valid from - 00101.5-2A

5-3 Undercarriage Assembly LT

RT-30 Serial # valid from - 06870.5-3A

R070T Serial # valid from - 00101.5-3A

- * **This manual covers illustrations and parts lists for U.S, Australian, and New Zealand machines, and is updated on a regular basis. Always refer to the current online version to ensure you have the most up to date information prior to ordering parts.**

NOTE: Ordering parts that are painted requires a specific part number format. Please refer to page II of this manual for paint code and ordering information.

TORSION AXLE ASSEMBLY

RT-30 valid from - 06870
RO70T valid from - 00101

Charter 5

REF. NO.	PART NUMBER	QTY.	DESCRIRTION	REF. NO.	PART NUMBER	QTY.	DESCRIRTION
1	2010-671	1	AXLE,TORSION,FRONT				
2	2010-672	1	AXLE,TORSION,REAR				
3	0304-100	4	WASHER,1/4"THICK				
4	8102-587	16	CAPSCREW,HH 5/8-11UNCx 2.0 GD8,ZN				
5	0402-621	16	NUT,TOP LOCK,STL,5/8-11UNC,ZN				
6	0700-287	32	WASHER,16mmX30mmX5mm				
7	2010-669	4	SPACER 1.50 X 2.25 X .134				
8	8102-404	4	CAPSCREW,HH 1/2-13UNCx1.25 GD8				
9	8051-332	4	WASHER,SPRING LOCK,1/2,ZN				

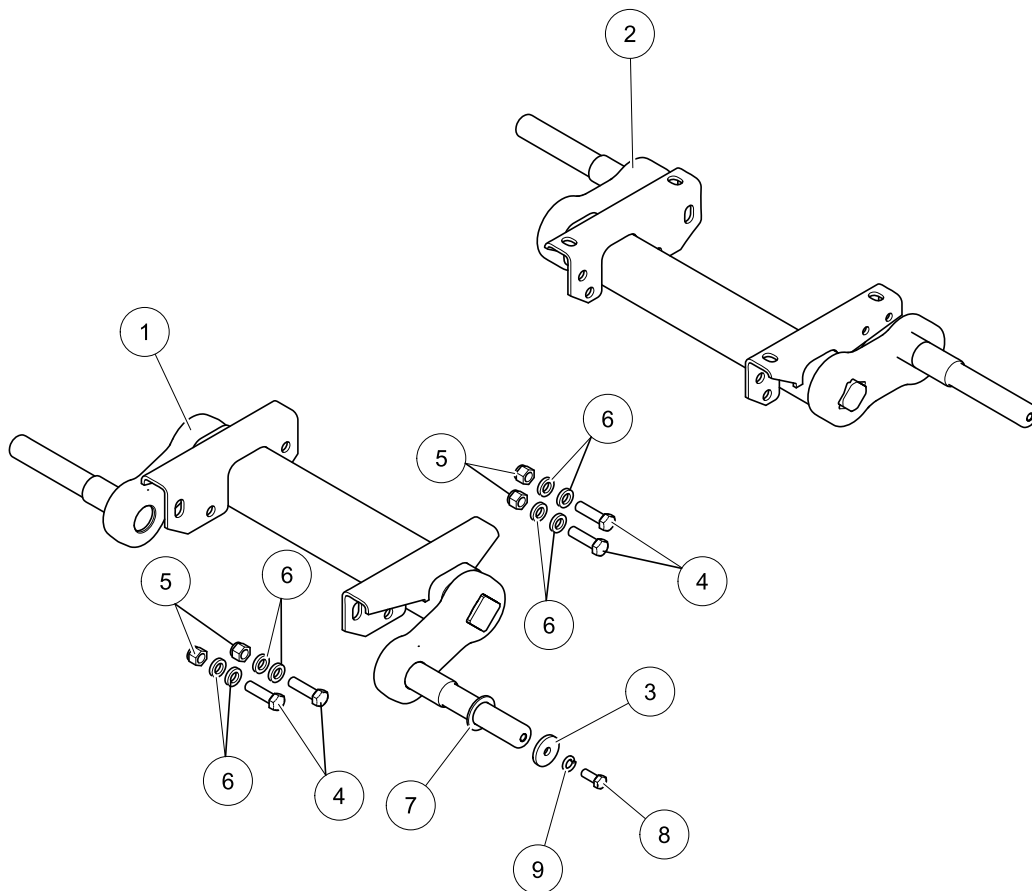

UNDERCARRIAGE ASSEMBLY RT

RT-30 valid from - 06870
RO70T valid from - 00101

Charter 5

REF. NO.	PART NUMBER	QTY.	DESCRIPTION	REF. NO.	PART NUMBER	QTY.	DESCRIPTION
1	0304-427	2	FITTING,GREASE,1/8 NRT x 45°	41	8042-490	1	NUT,HEX,3/8-16 UNC,GD8
2	2010-065	4	BUSHING,DU,1.50X1.66X2.00	42	0090-104	1	WASHER .402 x .728 x .098 HARD
3	2010-238	4	AXLE 1.25 X 9.5	43	2010-569	1	RING SPROCKET 10.623
4	0702-114	8	RING,RETAINER,INT	44	2010-034	1	RING,SPROCKET,10.623
5	0304-117	8	GUARD,BEARING	45	2010-783	1	ASSEMBLY, DRIVE SPROCKET, SERVICE
6	0303-141	8	SEAL,APY,1.250x2.062x.450	46	2010-247	8	ASSY RT30 WHEEL SERVICE
7	0302-591	16	BEARING,BALL,6205 W/O SEALS	47	2010-525	4	KIT END WHEEL 10" SERVICE
8	0304-097	8	SPACER,BEARING 1.0 ID X1.5 OD X 1/8 THI	48	0702-210	4	WASHER,4.41x2.00x.104
9	0304-101	8	WHEEL,10"	49	0090-477	2	RING SNAP EXT 1.5"
10	2010-572	1	WELDMENT RAIL RT30	50	2035-471	1	CAPSCREW SOC HD 3/8-16 x 1
11	0090-204	12	WASHER BEARING	51	2035-308	1	PIN,TENSIONER,THREADED
12	0304-722	12	NUT,HEX,JAM,LOCKING,3/4-10UNC				
13	2010-142	8	HUB CAP RUBBER BONDED				
14	0304-319	8	RING,SNAP,INNER WHEEL,PLATED				
15	0702-145	2	AXLE,MACHINED,10.32				
16	0702-115	8	RING,SNAP,INT,PLATED				
17	2010-517	4	WASHER 2.58 x 1.87 x .0897				
18	2060-044	4	SEAL 1.25 x 2.635 x .591				
19	0702-509	8	BEARING,CONE				
20	0702-508	8	BEARING,CUP				
21	0702-200	4	WHEEL,10",W/HUB				
22	8102-229	1	CAPSCREW,HH 3/8-16UNCx2.5,GD8				
23	0304-003	1	TRACK,11"WIDE,PROFILE2				
24	0702-111	4	CAP,WHEEL				
25	2010-766	1	SHAFT SWING JOINT				
26	2010-593	2	BUSHING DU 1.50 x 1.66 x 1.50				
27	2010-582	1	WELDMENT REAR PIVOT JOINT				
28	2035-308	1	PIN,TENSIONER,THREADED				
29	8102-225	1	CAPSCREW,HH,3/8-16 UNCx1.5,GD8,ZN				
30	2010-522	1	TABLE CAST MOTOR MACHINED RH				
31	0700-124	9	NUT,TOPLock,1/2-13UNC,ZN,GD8				
32	0304-098	9	TOOTH,DRIVE,SPROCKET				
33	0304-806	9	TUBE,SPROCKET				
34	8102-418	9	CAPSCREW,HH,1/2-13UNCx 6.0,GD8,ZN				
35	8040-786	1	NUT,HEX,NYLOCK,3/4-10 UNC,ZN				
36	0090-317	2	NUT HEX 1.25-7 UNC JAM ZINC				
37	0090-262	1	WASHER SAFETY S33-1.25"				
38	2035-448	1	CLEVIS END TENSIONER MACHINED				
39	2010-583	1	WELDMENT LOWER TENSIONER				
40	0304-408	1	CAPSCREW,HH,3/4-10UNC3.75,GD8				

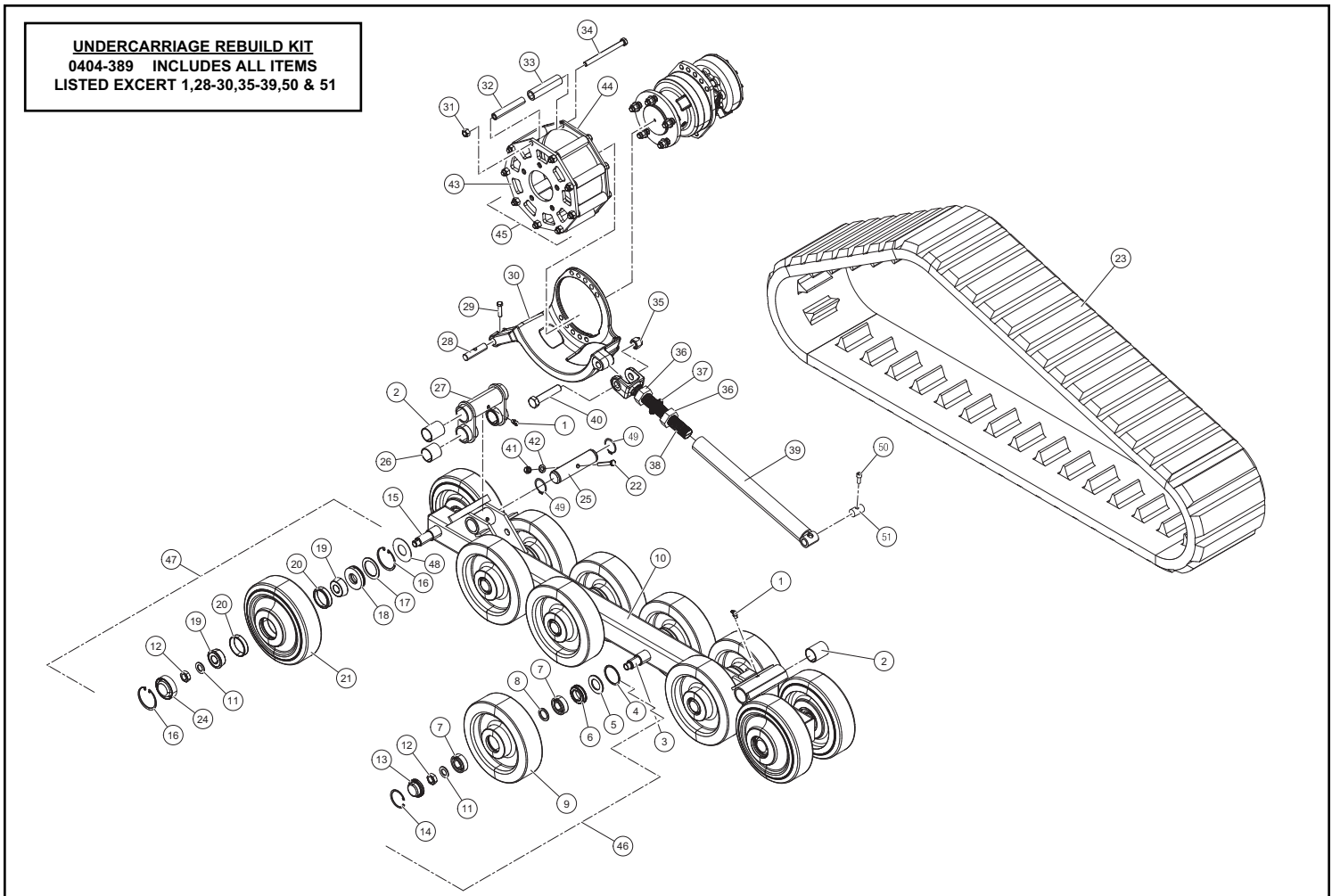

UNDERCARRIAGE ASSEMBLY LT

RT-30 valid from - 06870
RO70T valid from - 00101

Charter 5

REF. NO.	PART NUMBER	QTY.	DESCRIPTION	REF. NO.	PART NUMBER	QTY.	DESCRIPTION
1	0304-427	2	FITTING,GREASE,1/8 NRT x 45°	41	8042-490	1	NUT,HEX,3/8-16 UNC,GD8
2	2010-065	4	BUSHING,DU,1.50X1.66X2.00	42	0090-104	1	WASHER .402 x .728 x .098 HARD
3	2010-238	4	AXLE 1.25 X 9.5	43	2010-569	1	RING SPROCKET 10.623
4	0702-114	8	RING,RETAINER,INT	44	2010-034	1	RING,SPROCKET,10.623
5	0304-117	8	GUARD,BEARING	45	2010-783	1	ASSEMBLY, DRIVE SPROCKET, SERVICE
6	0303-141	8	SEAL,APY,1.250x2.062x.450	46	2010-247	8	ASSY RT30 WHEEL SERVICE
7	0302-591	16	BEARING,BALL,6205 W/O SEALS	47	2010-525	4	KIT END WHEEL 10" SERVICE
8	0304-097	8	SPACER,BEARING 1.0 ID X1.5 OD X 1/8 THI	48	0702-210	4	WASHER,4.41x2.00x.104
9	0304-101	8	WHEEL,10"	49	0090-477	2	RING SNAP EXT 1.5"
10	2010-572	1	WELDMENT RAIL RT30	50	2035-471	1	CAPSCREW SOC HD 3/8-16 x 1
11	0090-204	12	WASHER BEARING	51	2035-308	1	PIN,TENSIONER,THREADED
12	0304-722	12	NUT,HEX,JAM,LOCKING,3/4-10UNC				
13	2010-142	8	HUB CAP RUBBER BONDED				
14	0304-319	8	RING,SNAP,INNER WHEEL,PLATED				
15	0702-145	2	AXLE,MACHINED,10.32				
16	0702-115	8	RING,SNAP,INT,PLATED				
17	2010-517	4	WASHER 2.58 x 1.87 x .0897				
18	2060-044	4	SEAL 1.25 x 2.635 x .591				
19	0702-509	8	BEARING,CONE				
20	0702-508	8	BEARING,CUP				
21	0702-200	4	WHEEL,10",W/HUB				
22	8102-229	1	CAPSCREW,HH 3/8-16UNCx2.5,GD8				
23	0304-003	1	TRACK,11"WIDE,PROFILE2				
24	0702-111	4	CAP,WHEEL				
25	2010-766	1	SHAFT SWING JOINT				
26	2010-593	2	BUSHING DU 1.50 x 1.66 x 1.50				
27	2010-582	1	WELDMENT REAR PIVOT JOINT				
28	2035-308	1	PIN,TENSIONER,THREADED				
29	8102-225	1	CAPSCREW,HH,3/8-16 UNCx1.5,GD8,ZN				
30	2010-522	1	TABLE CAST MOTOR MACHINED RH				
31	0700-124	9	NUT,TOPLock,1/2-13UNC,ZN,GD8				
32	0304-098	9	TOOTH,DRIVE,SPROCKET				
33	0304-806	9	TUBE,SPROCKET				
34	8102-418	9	CAPSCREW,HH,1/2-13UNCx 6.0,GD8,ZN				
35	8040-786	1	NUT,HEX,NYLOCK,3/4-10 UNC,ZN				
36	0090-317	2	NUT HEX 1.25-7 UNC JAM ZINC				
37	0090-262	1	WASHER SAFETY S33-1.25"				
38	2035-448	1	CLEVIS END TENSIONER MACHINED				
39	2010-583	1	WELDMENT LOWER TENSIONER				
40	0304-408	1	CAPSCREW,HH,3/4-10UNC3.75,GD8.				

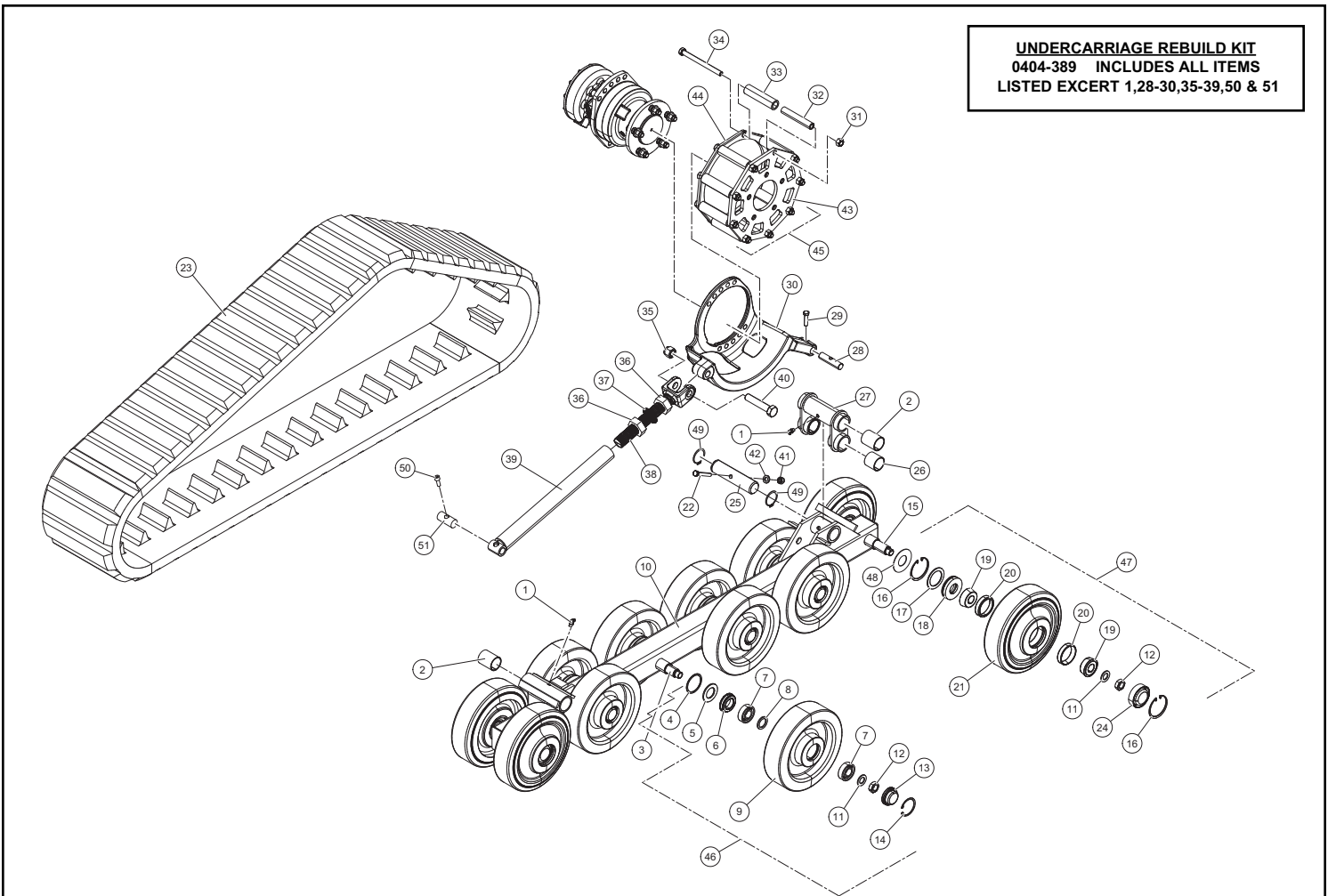

Charter 6

Mainframe

6-1 Chassis

RT-30 Serial # valid from - 06870.6-1A

R070T Serial # valid from - 00101.6-1A

6-2 Hood Assembly

RT-30 Serial # valid from - 06870.6-2A

R070T Serial # valid from - 00101.6-2A

- * **This manual covers illustrations and parts lists for U.S, Australian, and New Zealand machines, and is updated on a regular basis. Always refer to the current online version to ensure you have the most up to date information prior to ordering parts.**

NOTE: Ordering parts that are painted requires a specific part number format. Please refer to page II of this manual for paint code and ordering information.

CHASSIS ASSEMBLY

RT-30 valid from - 06870
RO70T valid from - 00101

Charter 6

REF. NO.	PART NUMBER	QTY.	DESCRIPTION	REF. NO.	PART NUMBER	QTY.	DESCRIPTION
1	2010-181	1	MAT FLOOR	41	2030-317	1	DOOR, FUEL
2	0304-045	1	SEAT	42	2010-107	1	PLATE,SKID,REAR
3	2076-409	1	BELT,SEAT 2" RETRACTABLE	43	2030-320	1	SPRING EXTENSION 2.36"
4	8050-282	6	WASHER,WROUGHT,3/8,STD,ZN	44	0090-137	2	SCREW SHOULDER-HSH 5/16-18 X 1.00
5	8102-404	6	CAPSCREW,HH 1/2-13UNCx1.25 GD8	45	2045-407	1	CAP FUEL GREEN
6	8040-606	8	NUT,HEX,NYLOCK,1/2-13 UNC,ZN	46	8102-128	7	CAPSCREW,HH 5/16-18UNCx7/8 GR8 ZN
7	8102-224	6	CAPSCREW,HH,3/8-16UNCx1.25,GD8	47	0304-241	1	SCREEN,BACK
8	0304-206	1	WLMT,MNT,SEAT,REAR	48	8102-039	3	CAPSCREW,HH,1/4-20UNCx.625,GD8
9	0200-390	4	CAPSCREW,HH,3/8-16x1.75",GD8	49	2010-457	1	SURROUND, ENGINE
10	2010-434	1	MOUNT SEAT FRONT	50	8050-342	1	WASHER,WROUGHT,1/2,ZN
11	8102-130	4	CAPSCREW,HH 5/16-18x3/4,GR8	51	8050-347	3	WASHER,WROUGHT,1/2,STD,ZN
12	0300-732	5	CLAMP,HOSE,#4	52	8102-412	2	CAPSCREW,HH 1/2-13UNCx3.25
13	0200-361	1	HOSE,FUEL,3/16IDx35.00"	53	8102-409	2	CAPSCREW,HH,1/2-13 UNCx2.5,GD8
14	0304-510	1	HOSE,FUEL,5/16x34"	54	2010-466	2	WEIGHT REAR
15	2010-210	1	ASSY SENDING UNIT	55	0304-662	1	HARNESSEAT
16	0304-447	1	HOSE,7/16X5/16POLY,1.30FT	56	2030-583	1	COVER FIREWALL
17	0301-375	1	WEIGHT,IN-TANK	57	8102-044	4	CAPSCREW,HH,1/4-20UNCx1.25,GD8,ZN
18	8102-130	1	CAPSCREW,HH 5/16-18x3/4,GR8	58	8051-212	2	WASHER,SPRING LOCK,1/4,ZN
19	8050-262	16	WASHER,WROUGHT,5/16,STD,ZN	59	8050-221	5	WASHER,FLAT,1/4,SAE
20	0200-367	1	HOSE,FUEL,VENT,3/8IDx30.00"	60	0090-534	1	CLAMP
21	0303-096	2	CLAMP,HOSE	61	0310-465	2	CLAMP,WIRE,5/8,RBC-5/8
22	2010-772	1	HOSE FILL DIESEL RT30	62	2046-070	1	CLAMP P 2"
23	8051-242	4	WASHER,SPRING LOCK,5/16,ZN	63	0402-263	4	NUT,HEX,NYLOCK5/16-18,INSERT/C
24	0200-437	2	PLUG,HOLE,6"	64	8050-247	4	WASHER,WROUGHT,5/16,SAE,ZN
25	2010-184	1	WLMT FUEL TANK	65	8102-128	4	CAPSCREW,HH 5/16-18UNCx7/8 GR8
26	8102-222	19	CAPSCREW,HH,3/8-16 UNCx1.0,GD8	66	0302-537	9	SCREW,HWH,TAPPING,5/16-18x3/4,
27	0300-980	4	WASHER,1.447 x .406 x .125	67	0310-467	8	CLAMP,WIRE,1.0,RBC-1
28	2010-559	1	WLMT FLOOR PAN	68	0090-623	2	PLUG RIBBED 1.21" -1.3" ID
29	0304-198	1	PLATE,SKID,CENTER				
30	8051-272	25	WASHER,SPRING LOCK,3/8,ZN				
31	2010-150	1	WLMT,CHASSIS,RT-30 (WHITE)				
32	0201-477	2	CPIN,LOCKING,D-RING,3.00"				
33	0304-157	5	SCREW,ORING,3/16-32x1/2,STAINL				
34	0090-139	2	BUSHING PLASTIC .5 OD X .38 ID				
35	2030-315	1	MOUNT,DOOR,FUEL				
36	0090-138	2	SCREW CAP HSFH 5/16-18 X .75 BLK ZC				
37	2010-443	1	STOP LOADER				
38	0090-003	2	NUT,WELD,HEX,5/16-18				
39	0304-617	1	GASKET,TANK,FUEL				
40	2010-127	1	SWITCH,SEAT (TWIST IN STYLE)				

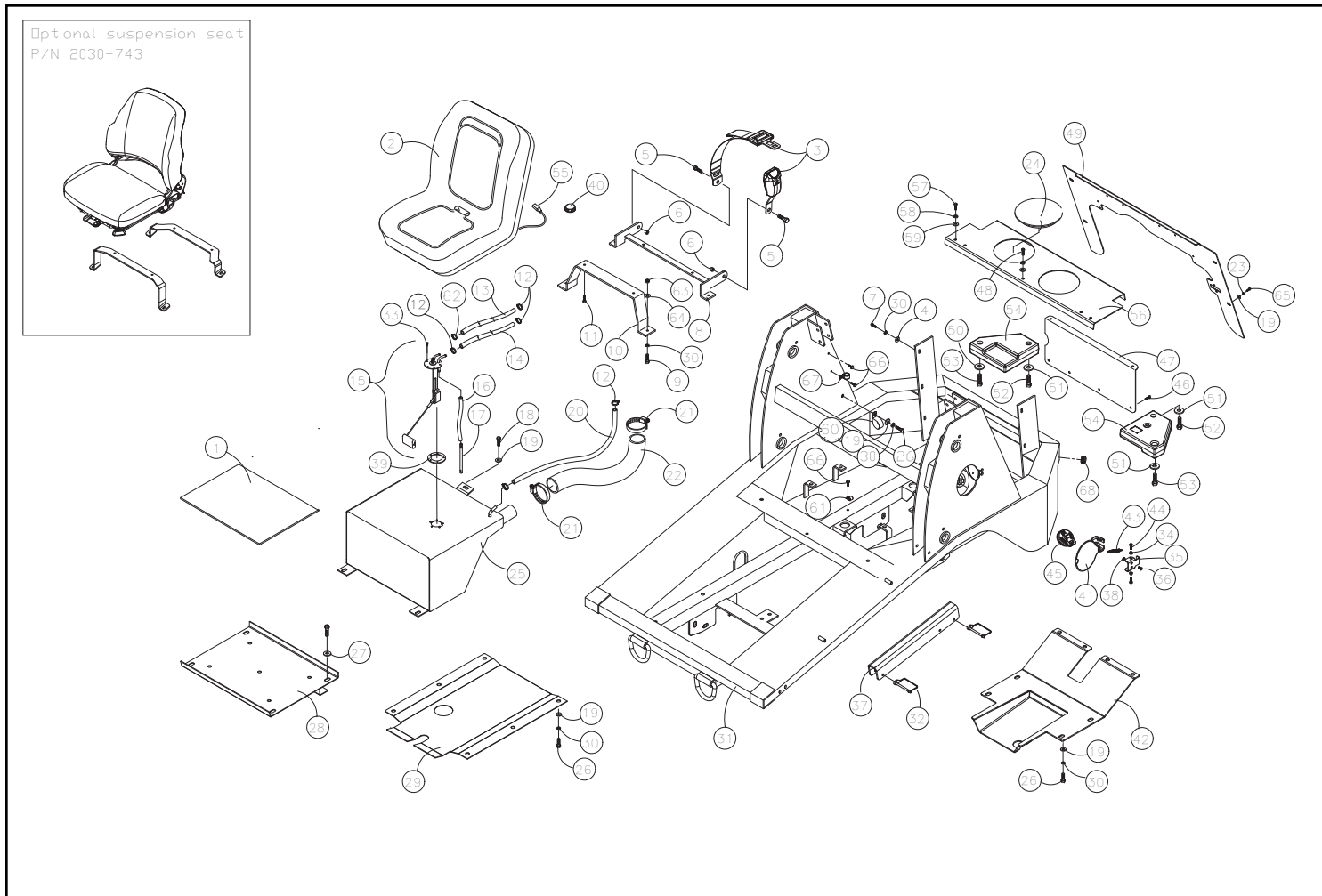

HOOD ASSEMBLY

RT-30 valid from - 06870
RO70T valid from - 00101

Charter 6

REF. NO.	PART NUMBER	QTY.	DESCRIRTION	REF. NO.	PART NUMBER	QTY.	DESCRIRTION
1	8061-648	4	RIVET,LARGE HEAD,3/16 x .575 A				
2	2010-196	1	PAWL LOCK				
3	2030-387	1	LOCK SOUTHCO				
4	0307-779	2	HINGE,DETACHABLE				
5	8060-728	4	RIVET,BLIND 3/16X.126-.250 Grip Range Stainless				
6	2010-754	1	TRIM LONG HOOD				
7	2010-753	1	TRIM SHORT HOOD				
8	0200-232	2	SPRING,GAS ASSIST				
9	0314-528	2	MOUNT GAS SPRING BALL 10MM				
10	0090-459	4	RIVET BLIND - 3/16 DIA- RANGE .251" - .375"				
11	0403-977	2	KEEPER				
12	8402-040	4	CAPSCREW,HH,1/4-20 UNCx.75,GD8 ZN				
13	2010-764	2	DEFLECTOR HOOD				
14	8050-222	8	WASHER,WROUGHT,1/4,STD,ZN				
15	8040-366	4	NUT,HEX,NYLOCK,1/4-20 UNC,ZN				

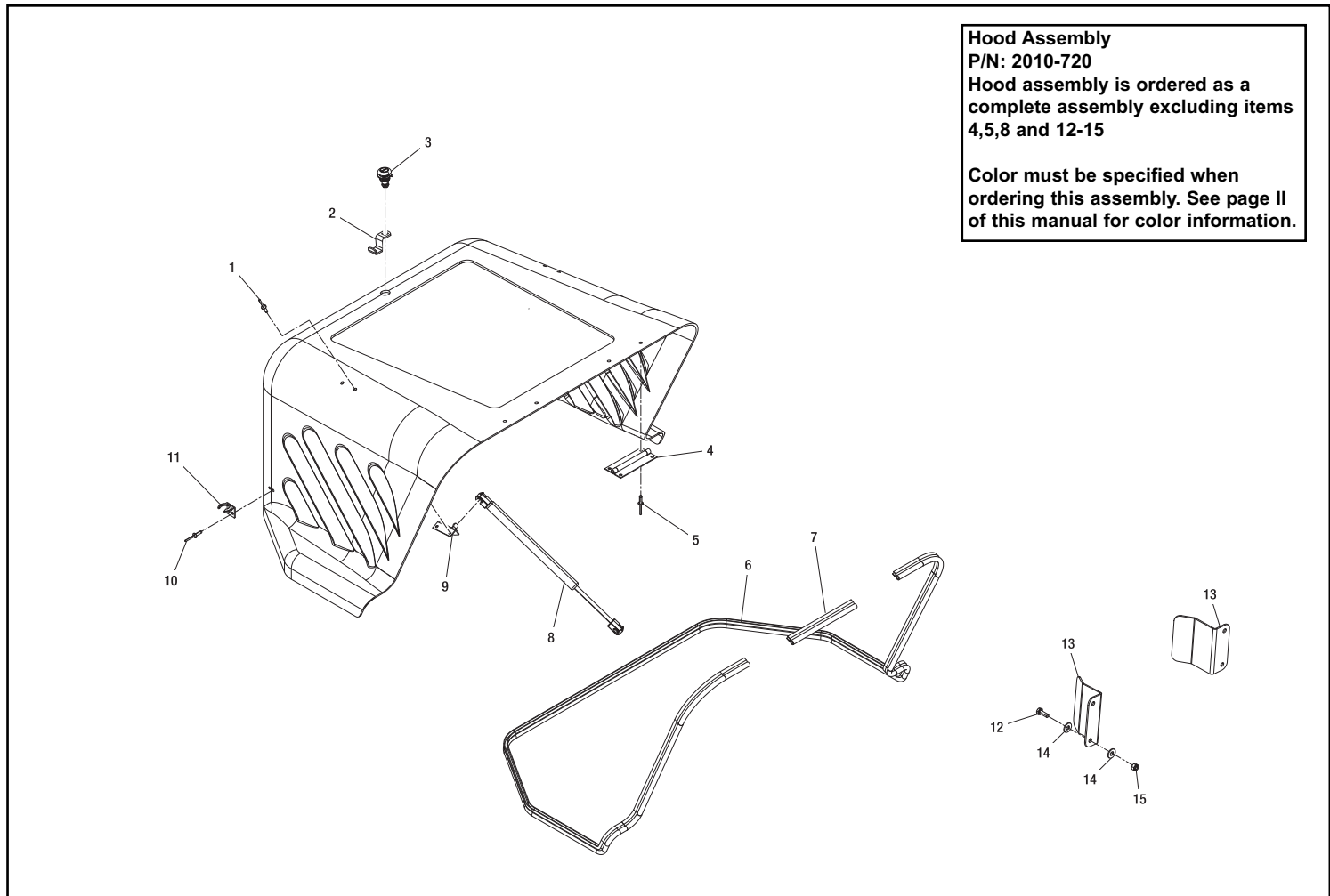

Charter 7

Cab / Heating

7-1 Cab

RT-30 Serial # valid from - 06870.7-1A

R070T Serial # valid from - 00101.7-1A

7-2 Enclosed Cab

RT-30 Serial # valid from - 06870.7-2A

R070T Serial # valid from - 00101.7-2A

7-3 Heater

RT-30 Serial # valid from - 06870.7-3A

R070T Serial # valid from - 00101.7-3A

- * **This manual covers illustrations and parts lists for U.S, Australian, and New Zealand machines, and is updated on a regular basis. Always refer to the current online version to ensure you have the most up to date information prior to ordering parts.**

NOTE: Ordering parts that are painted requires a specific part number format. Please refer to page II of this manual for paint code and ordering information.

CAB (R.O.P.S.) ASSEMBLY

RT-30 valid from - 06870
RO70T valid from - 00101

Charter 7

REF. NO.	PART NUMBER	QTY.	DESCRIPTION	REF. NO.	PART NUMBER	QTY.	DESCRIPTION
1	0304-318	1	BOX,OWNERS MANUAL	41	0304-473	1	SENSOR,SWITCH,LAPBAR
2	2010-688	1	HARNES CAB RT30 PWR ACT	42	0310-308	4	NUT,HEX,NYLOCK 4-40,91831A005
3	0304-019	1	ASSY,LAP BAR	43	0412-036	1	BRACKET LAP BAR ACTIVATION SWITCH
4	0310-307	4	SCREW,MACHINE,4-40x.50 92314A110	44	0200-288	1	BULB,HALOGEN
5	0200-600	2	MNTS JOYSTICK	45	0200-290	1	INSULATION, TOP
6	0304-496	1	PAD,SKID	46	0090-172	5	TIE CABLE TREE MOUNT 50 LB
7	0200-588	1	CONSOLE RH	47	2030-511	1	WROPS RT30/50/60
8	0200-587	1	CONSOLE LH	48	0301-637	1	GROMMET (1840)
9	0302-546	1	KNOB,PLASTIC,1-7/8 DIA,1/2-13	49	0304-247	1	LIGHT,REAR
10	0314-269	6	NUT,FLANGE,TOPLK,3/8-16UNC,GDG,ZN	50	8051-212	5	WASHER,SPRING LOCK,1/4,ZN
11	0303-071	2	WASHER,NYLON,BLACK,1" OD	51	0200-320	2	WLMT,STOP LAP BAR
12	8040-486	1	NUT,HEX,NYLOCK,3/8-16 UNC,ZN	52	0200-321	2	PAD,RUBBER,W/ADHESIVE
13	0303-099	2	WASHER,STAR,3/8,INT/EXT TOOTH	53	8102-040	4	CAPSCREW,HH,1/4-20 UNCx.75,GD8 ZN
14	0304-485	4	SCREW,MACH,10-24x3/4,STAINLESS	54	0090-325	4	WASHER 3/4"-5/16" RUBBER BONDED
15	0090-165	4	SCREW MACHINE #10-24 X 1-1/4" ZN	55	8050-222	4	WASHER,WROUGHT,1/4,STD,ZN
16	0090-163	4	NUT U 10-24 UNC	56	8040-366	4	NUT,HEX,NYLOCK,1/4-20 UNC,ZN
17	8102-222	6	CAPSCREW,HH,3/8-16 UNCx1.0,GD8,ZN				
18	0200-291	1	INSULATION,MIDDLE				
19	2030-520	1	PLATE,FIREWALL				
20	0200-264	1	HOUSING,POWER SOURCE				
21	0304-579	6	PLUG,HOLE,PLASTIC,5/16				
22	0201-549	1	WLMT,LEVER,THRITTLE				
23	0304-501	1	TUBING, SPACER				
24	8011-227	1	BOLT,CARRIAGE,3/8-16 UNC x 2.0				
25	0090-012	8	WASHER FINISHING #10 SS				
26	2045-510	2	PLUG HOLE 1.375" P				
27	0200-292	1	INSULATION,BOTTOM				
28	0304-466	1	STOP,LAPBAR				
29	8050-240	4	WASHER,STAINLESS,1/4",MS				
30	0304-465	4	CAPSCREW,HH,M6-1.0x16mm				
31	0304-467	1	BRKT,LAPBAR				
32	8040-606	4	NUT,HEX,NYLOCK,1/2-13 UNC,ZN				
33	0304-468	2	RING,SNAP,LAPBAR				
34	8102-404	4	CAPSCREW,HH 1/2-13UNCx1.25 GD8				
35	8102-044	5	CAPSCREW,HH,1/4-20UNCx1.25,GD8				
36	0304-470	1	MNT,LAPBAR				
37	0304-477	2	SPACER,LAPBAR				
38	0304-471	2	SPRING,GAS,ASSIST				
39	0304-472	1	MNT,LAPBAR,SWITCH				
40	0304-476	1	GROMMET,RUBBER				

Interior Panels

P/N: 2030-629 RH Side Panel
P/N: 2030-630 LH Side Panel
P/N: 4030-124 Headliner
P/N: 0200-457 RT-RR Corner Panel
P/N: 0200-458 LT-RR Corner Panel
P/N: 0200-460 Rear Deck Panel (Top)
P/N: 0200-459 Back Panel (Firewall)
P/N: 0200-455 RT Side Console Mat
P/N: 0200-456 LT Side Console Mat

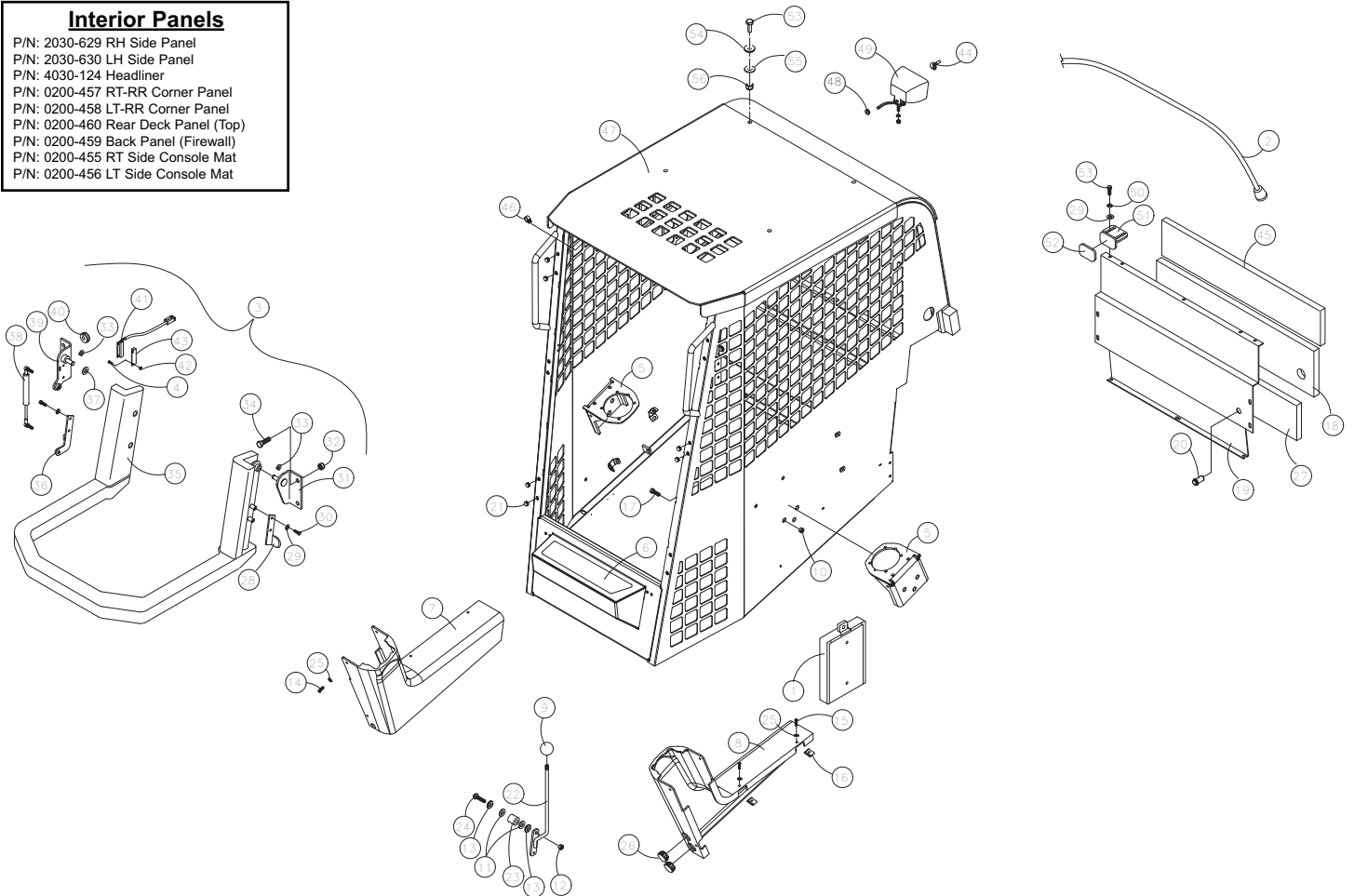

ENCLOSED CAB (R.O.P.S.) ASSEMBLY

RT-30 valid from - 06870
RO70T valid from - 00101

Charter 7

REF. NO.	PART NUMBER	QTY.	DESCRIPTION	REF. NO.	PART NUMBER	QTY.	DESCRIPTION
1	0403-762	2	WINDOW UPPER CORNER	41	0403-842	1	WINDOW REAR
2	0402-769	1	GLASS,SLIDER,SINGLE,RH	42	0402-758	1	GLASS,SLIDER,SINGLE,LH
3	4010-125	2	PANEL PLASTIC LOWER SCREENS	43	0403-854	1	CATCH WINDOW RH
4	2075-406	1	HANDLE PUSH BUTTON	44	0090-304	1	KNOB STAR 1.75" RED
5	0403-503	2	BUSHING,HINGE	45	0403-767	1	SEAL RH UPPER WINDOW
6	2075-409	1	MOUNT DOOR LATCH	46	8050-222	5	WASHER,WROUGHT,1/4,STD,ZN
7	8040-426	8	NUT,HEX,NYLOCK,5/16-18 UNC,ZN	47	8051-212	5	WASHER,SPRING LOCK,1/4,ZN
8	0304-619	1	MOTOR,WIPER,85^	48	8050-262	8	WASHER,WROUGHT,5/16,STD,ZN
9	0310-495	12'	STRIP,LOCK	49	0090-055	7'	SEAL BULB 1.00 x 1.00
10	0304-674	1	SEAL,WINDOW,10FT	50	0403-847	1	LATCH ARM LH
11	0402-243	1	ARM,WIPER,15-19"	51	0403-913	1	T-HANDLE NON LOCKING
12	0304-557	1	BLADE,FLAT,14"	52	0403-845	1	WLMT FRAME WINDOW REAR
13	4030-106	1	WINDOW DOOR RT30/60 CE	53	0403-850	2	HINGE REAR WINDOW MALE
14	8102-040	4	CAPSCREW,HH,1/4-20 UNCx.75,GD8	54	0403-846	1	T-HANDLE LOCKING
15	8050-222	4	WASHER,WROUGHT,1/4,STD,ZN	55	8061-604	5	RIVET,ALUMINUM,3/16x.575
16	8040-426	2	NUT,HEX,NYLOCK,5/16-18 UNC,ZN	56	0310-641	1	MOUNT,SHOCK,90^
17	0304-495	2	STUD,BALL,10MM STUD	57	2045-503	1	SPRING GAS ASSIST
18	0090-123	11'	TRIM,CAB	58	0200-552	1	MNT,BRACKET,BALLSTUD
19	2030-348	1	MOUNT SPRING	59	0200-545	4	CLIP,SAFETY,GAS SPRING
20	8050-240	1	WASHER,STAINLESS,1/4",MS	60	0200-606	1	PANEL ROOF LEXAN
21	0304-486	1	CAPSCREW,HH,M6-1.0x14	61	0403-478	1	WLMT,DOOR,W/HINGES (SEE NOTE)
22	0403-481	2	ASSY HINGE DOOR CAST LH	62	0403-766	1	SEAL LH UPPER WINDOW
23	2075-408	1	STRIKE	63	0403-853	1	CATCH WINDOW LH
24	0090-059	2	SCREW MACHINE #10 x .63 PH SELF DRILLING	64	0403-764	1	SEAL LH UPPER WINDOW
25	8102-136	6	CAPSCREW,HH,5/16-18x1.75 ZN GD	65	0403-765	1	SEAL LH LOWER WINDOW
26	0403-848	1	LATCH ARM RH	66	8102-039	5	CAPSCREW,HH,1/4-20UNCx.625,GD8
27	2075-407	1	HANDLE INSIDE	67	0090-347	10	SCREW TH PH 1/4-20 X 1.25 ZN
28	2075-416	1	MOUNT STRIKE	68	0090-622	1	MACH, PH PAN HD, M6-1.0 X 10MM CLR ZNC
29	0403-896	1	SWITCH DOOR PUSH BUTTON				
30	0090-135	1	NUT NYLOCK M12 X 1.0 ZC				
31	0304-573	1	HARNES, WIPER, B				
32	0403-630	1	SPRING DAMPENED DOOR				
33	0090-167	4	TIE CABLE MOUNT				
34	8102-135	2	CAPSCREW,HH,5/16-18X1.50ZN,GD8				
35	0200-607	1	SEAL PANEL ROOF				
36	8102-042	32	CAPSCREW, HH 1/4-20UNC 1" GD8				
37	2030-511	1	ROPS RT30/50/60				
39	0310-495	5.1'	STRIP,LOCK				
38	0201-748	2	ASSY,TAG,EMERGENCY EXIT				
40	1059-015	5.1'	SEAL,WINDOW				

**NOTE: Australian & New Zealand Machines
Part # 4030-016**

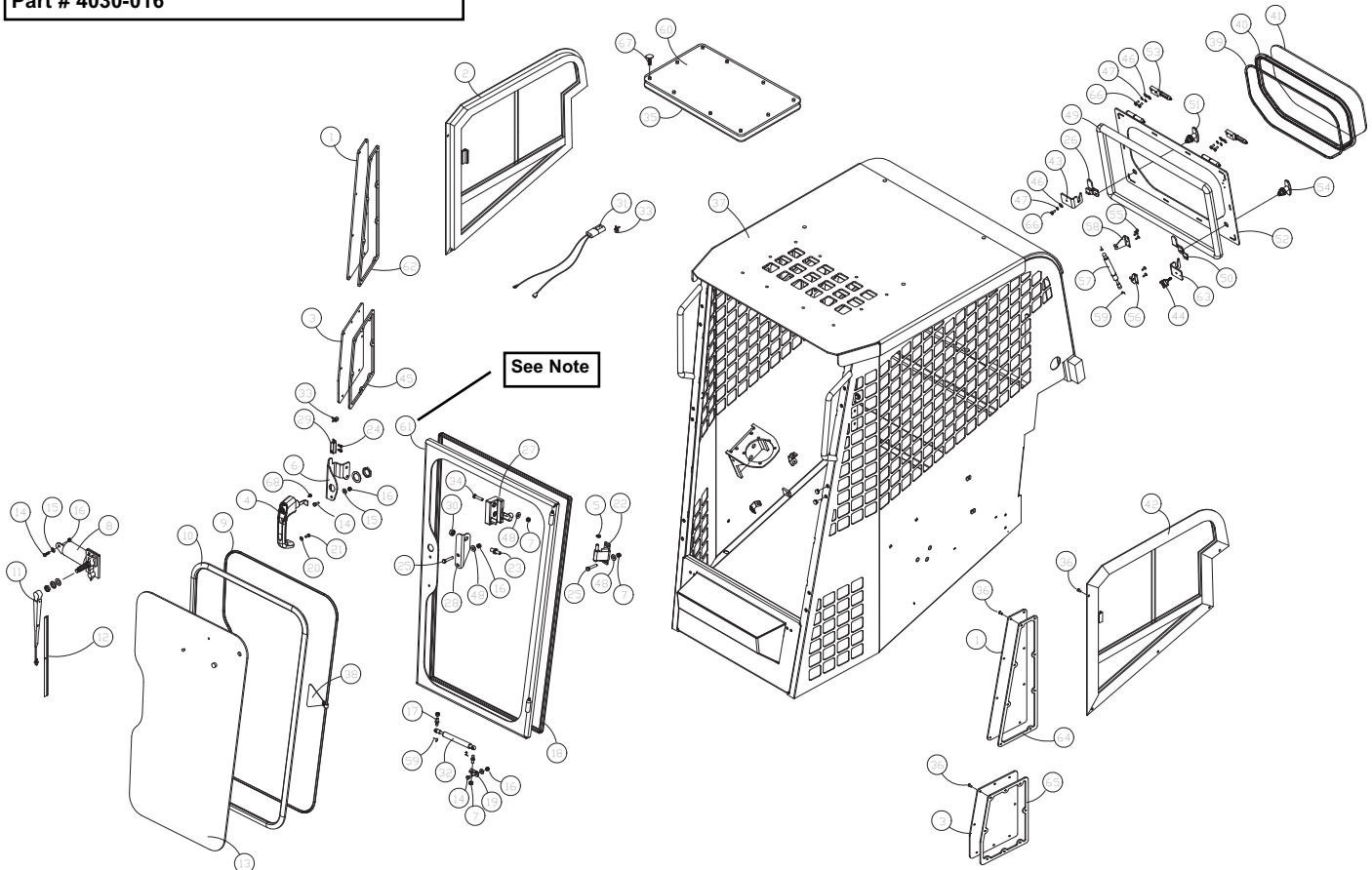

CAB HEATER ASSEMBLY

RT-30 valid from - 06870
RO70T valid from - 00101

Charter 7

REF. NO.	PART NUMBER	QTY.	DESCRIRTION	REF. NO.	PART NUMBER	QTY.	DESCRIRTION
1	0304-546	1	HEATER,CAB, RC-30				
2	0304-548	2	MNT,HEATER				
3	0305-214	1	HOSE,HEATER,5/8 x 33"				
4	0304-553	1	HOSE,HEATER,5/8,72"				
5	0304-554	1	HOSE,HEATER,5/8,38"				
6	0301-558	1	VALVE,FLOW,HEATER				
7	0401-975	1	CABLE,PUSH-PULL,HEATER				
8	0301-514	1	KNOB,SWITCH,HEATER				
9	8102-038	2	CAPSCREW,HH 1/4-20UNCx7/8 GRD8				
10	8040-366	2	NUT,HEX,NYLOCK,1/4-20 UNC,ZN				
11	0301-654	1	NUT,JAM,3/8-24 UNF				
12	0301-110	6	CLAMP,HOSE,#8				
13	2045-748	2	GROMMET,RUBBER,1-3/8"				
14	0304-670	1	ADARTER,5/8BARB-3/8MRT-90^				
15	0304-570	1	ADARTER,6MP-10HOSE,BARB				
16	8051-212	4	WASHER,SPRING LOCK,1/4,ZN				
17	8102-039	4	CAPSCREW,HH,1/4-20UNCx.625,GD8				
18	0310-713	1	GASKET, SWITCH				
19	0304-575	1	HARNES,HEATER				
20	0304-122	1	SWITCH,ON/OFF,HEATER				
21	0310-587	4	CLAMP,WIRE,3/8,ADHESIVE				
22	8050-222	6	WASHER,WROUGHT,1/4,STD,ZN				

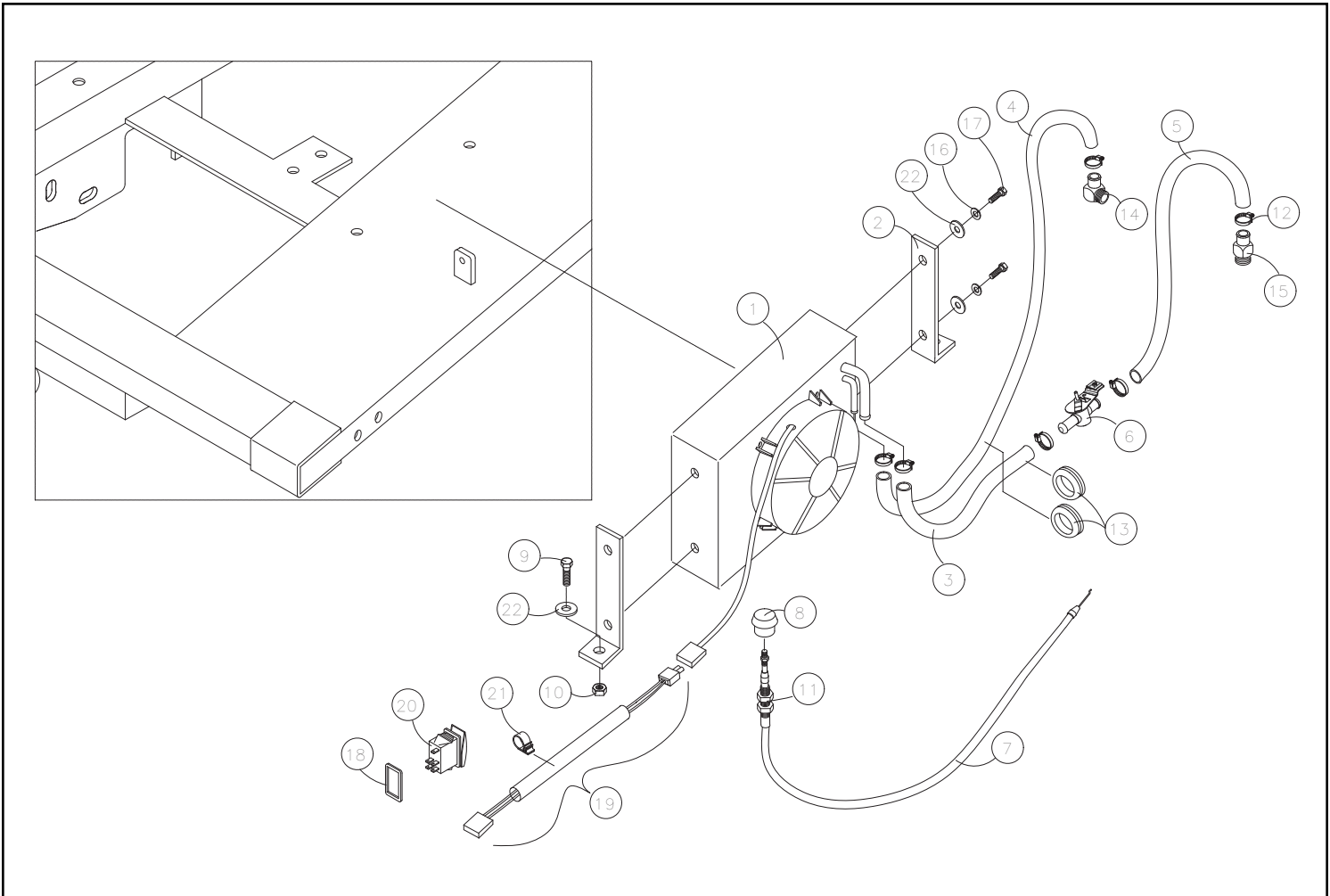

Charter 8

Quick Attach

8-1 Quick Attach

RT-30 Serial # valid from - 06870.8-1A

R070T Serial # valid from - 00101.8-1A

8-1 Quick Attach Adarter

RT-30 Serial # valid from - 06870.8-2A

R070T Serial # valid from - 00101.8-2A

- * **This manual covers illustrations and parts lists for U.S, Australian, and New Zealand machines, and is updated on a regular basis. Always refer to the current online version to ensure you have the most up to date information prior to ordering parts.**

NOTE: Ordering parts that are painted requires a specific part number format. Please refer to page II of this manual for paint code and ordering information.

QUICK ATTACH ASSEMBLY

RT-30 valid from - 06870
RO70T valid from - 00101

Charter 8

REF. NO.	PART NUMBER	QTY.	DESCRIRTION	REF. NO.	PART NUMBER	QTY.	DESCRIRTION
1	2010-527	1	WLMT QUICK ATTACH				
2	8102-229	2	CAPSCREW,HH 3/8-16UNCx2.5,GD8				
3	2010-538	2	TUBE LATCH				
4	0400-652	2	SPRING,COMPRESSION, .88 x .88 x .091				
5	2010-444	2	HANDLE QUICK ATTACH				
6	0400-617	2	BLOCK,LATCH				
7	8040-486	2	NUT,HEX,NYLOCK,3/8-16 UNC,ZN				
8	0400-651	2	SPRING,COMPRESSION PLATED				
9	0400-621	2	SPOOL,PIVOT				
10	2010-412	1	PIN QA WLMT LH				
11	8102-418	2	CAPSCREW,HH,1/2-13UNCx 6.0,GD8,ZN				
12	2010-413	1	PIN QA WLMT RH				
13	0400-653	2	CAPSCREW,SHOULDER,.5 x.63x3/8-				
14	0300-607	2	ZERK,GREASE,1/4-28				
15	2010-526	8	PIN BOSS				

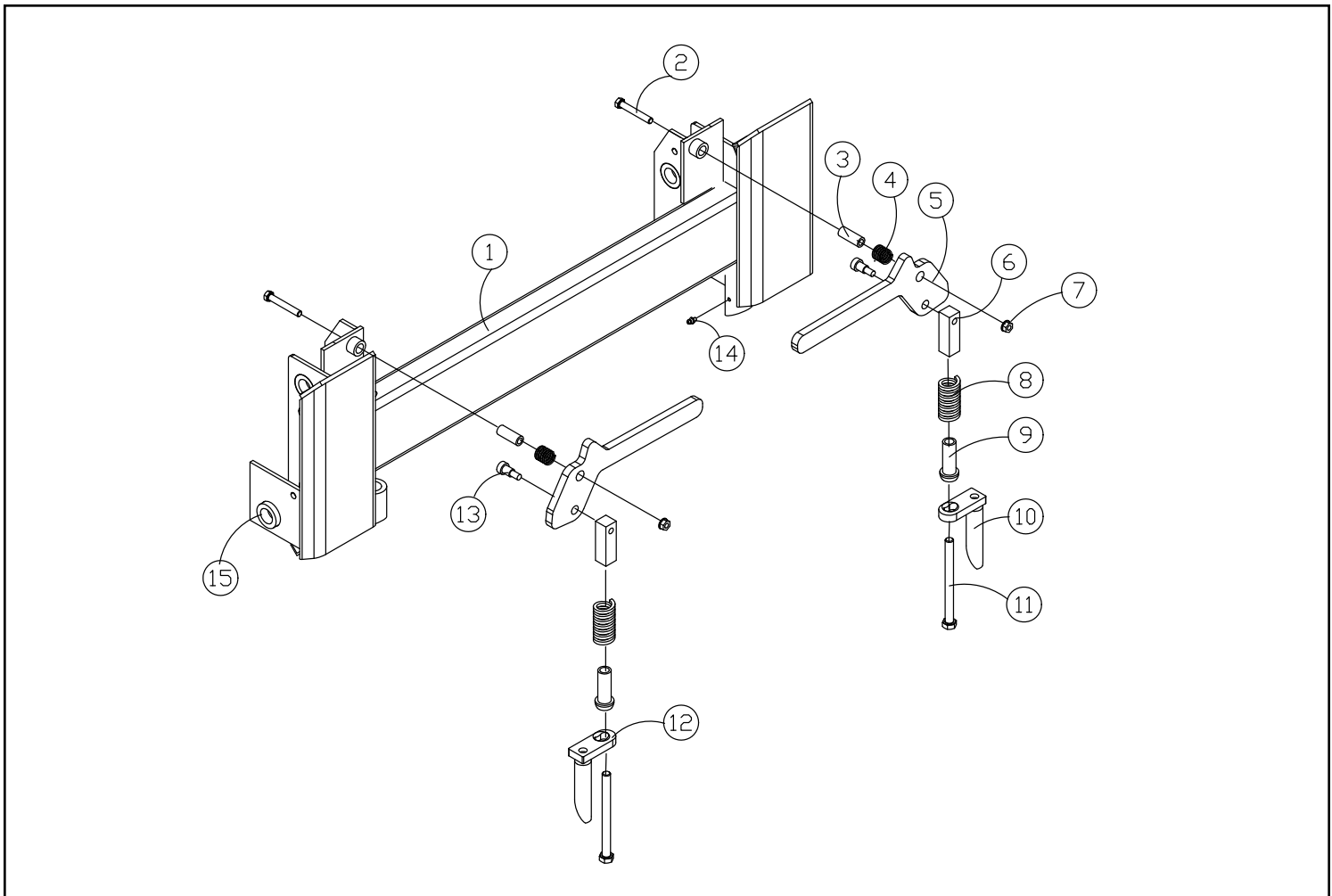

QUICK ATTACH ADAPTER

RT-30 valid from - 06870
RO70T valid from - 00101

Charter 8

REF. NO.	PART NUMBER	QTY.	DESCRIPTION	REF. NO.	PART NUMBER	QTY.	DESCRIPTION
1	8102-418	2	CAPSCREW,HH,1/2-13UNCx 6.0,GD8				
2	0400-676	1	WLMT,PIN,LATCH,RH				
3	0400-621	2	SPOOL,PIVOT				
4	0400-651	2	SPRING,COMPRESSION				
5	8050-347	8	WASHER,WROUGHT,1/2,STD,ZN				
6	0400-653	2	CAPSCREW,SHOULDER,.5 x.63x3/8-				
7	0400-617	2	BLOCK,LATCH				
8	8102-222	2	CAPSCREW,HH,3/8-16 UNCx1.0,GD8				
9	8051-272	2	WASHER,SPRING LOCK,3/8,ZN				
10	8050-262	2	WASHER,WROUGHT,5/16,STD,ZN				
11	0400-697	1	LEVER,LATCH,LH				
12	0400-652	2	SPRING,COMPRESSION,.88 x .88 x				
13	0304-941	1	CONVERTER,QUICK ATTACH,RC30				
14	0400-698	1	LEVER,LATCH,RH				
15	0400-620	1	WLMT,PIN,LATCH,LH				
16	0400-634	4	SLIDE,PLASTIC,QUICK-ATTACH				
17	0400-629	2	STAND-OFF,LEVER,LATCH				

Quick Attach Adapter Assembly

P/N: 0402-581

Includes all items needed to convert Quick Attach to universal size.

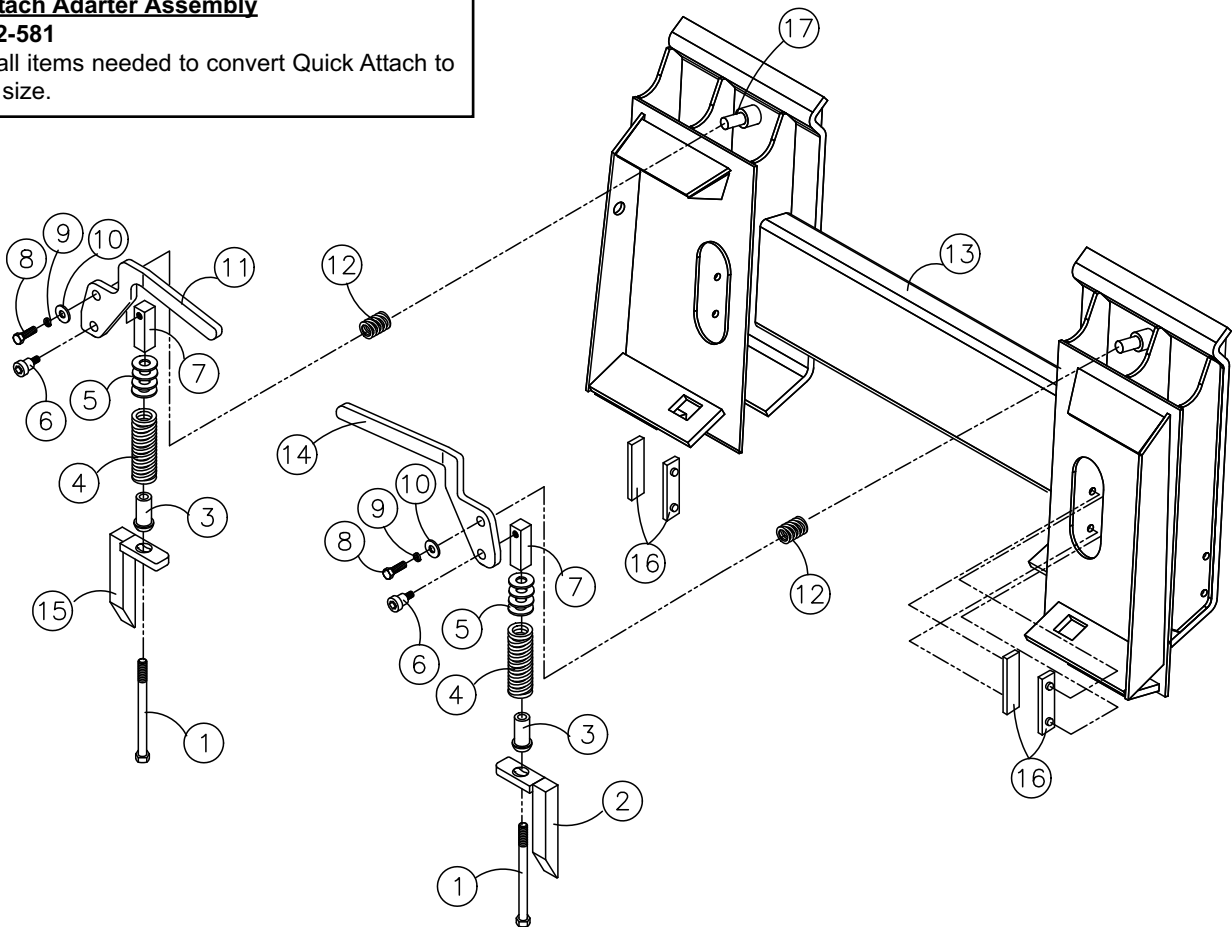

Charter 9

Graphics / Safety Decals

9-1 Safety Decals U.S (ANSI)

RT-30 Serial # valid from - 06870. 9-1A

R070T Serial # valid from - 00101. 9-1A

9-2 Safet Decals R.O.W. (ISO)

RT-30 Serial # valid from - 06870. 9-2A

R070T Serial # valid from - 00101. 9-2A

9-3 Compact Power Equipment Safety Decals

R070T Serial # valid from - 00101. 9-3A

9-4 Machine Graphics

RT-30 (ASV) Serial # valid from - 06870. . 9-4A

RT-30 (Australia/New Zealand)

Serial # valid from - 06870. 9-4B

R070T (Terex) Serial # valid from - 06870. . 9-4C

- * **This manual covers illustrations and parts lists for U.S, Australian, and New Zealand machines, and is updated on a regular basis. Always refer to the current online version to ensure you have the most up to date information prior to ordering parts.**

SAFETY DECALS US (ANSI)

RT-30 valid from - 06870
RO70T valid from - 00101

Charter 9

REF. NO.	PART NUMBER	QTY.	DESCRIRTION	REF. NO.	PART NUMBER	QTY.	DESCRIRTION
1	0304-320	1	DECAL MANUAL BOX				
2	2030-599	1	DECAL ANSI FIRE HAZARD (BRUSHCUTTING)				
3	2030-602	2	DECAL ANSI SKIN INJECTION HAZARD				
4	4046-078	1	DECAL DIESEL FUEL ONLY				
5	2030-593	2	DECAL ANSI RUN OVER HAZARD				
6	2030-603	1	DECAL ANSI BATTERY EXPLOSION HAZARD				
7	2030-595	1	DECAL ANSI RADIATOR HAZARD				
8	2030-600	1	DECAL ANSI BELT FAN HAZARD				
9	2030-601	1	DECAL ANSI HOT SURFACES HAZARD				
10	4046-079	1	DECAL CE HYDRAULIC OIL ONLY				
11	0310-197	4	DECAL, TIE DOWN 156-5762				
12	0304-305	1	DECAL, THROTTLE				
13	2030-628	1	DECAL ANSI 2 SPEED				
14	2030-598	1	DECAL ANSI READ O&M ROLLOVER FALL HAZARD				
15	2030-596	1	DECAL ANSI ROLLOVER FALL HAZARD				
16	2030-424	1	DECAL CONTROLS RIGHT (NO TEXT)				
17	2030-423	1	DECAL CONTROLS LEFT (NO TEXT)				
18	2030-597	1	DECAL ANSI FALL HAZARD (3 POINT ENTRY)				
19	2030-592	2	DECAL ANSI LOADER CRUSH HAZARD				
20	2030-594	2	DECAL ANSI LIFT ARM BRACE				
21	2010-592	1	DECAL EMERGENCY EXIT ANSI				
22	2085-253	2	DECAL ANSI CLEAN UNDERCARRIAGES NOTICE				

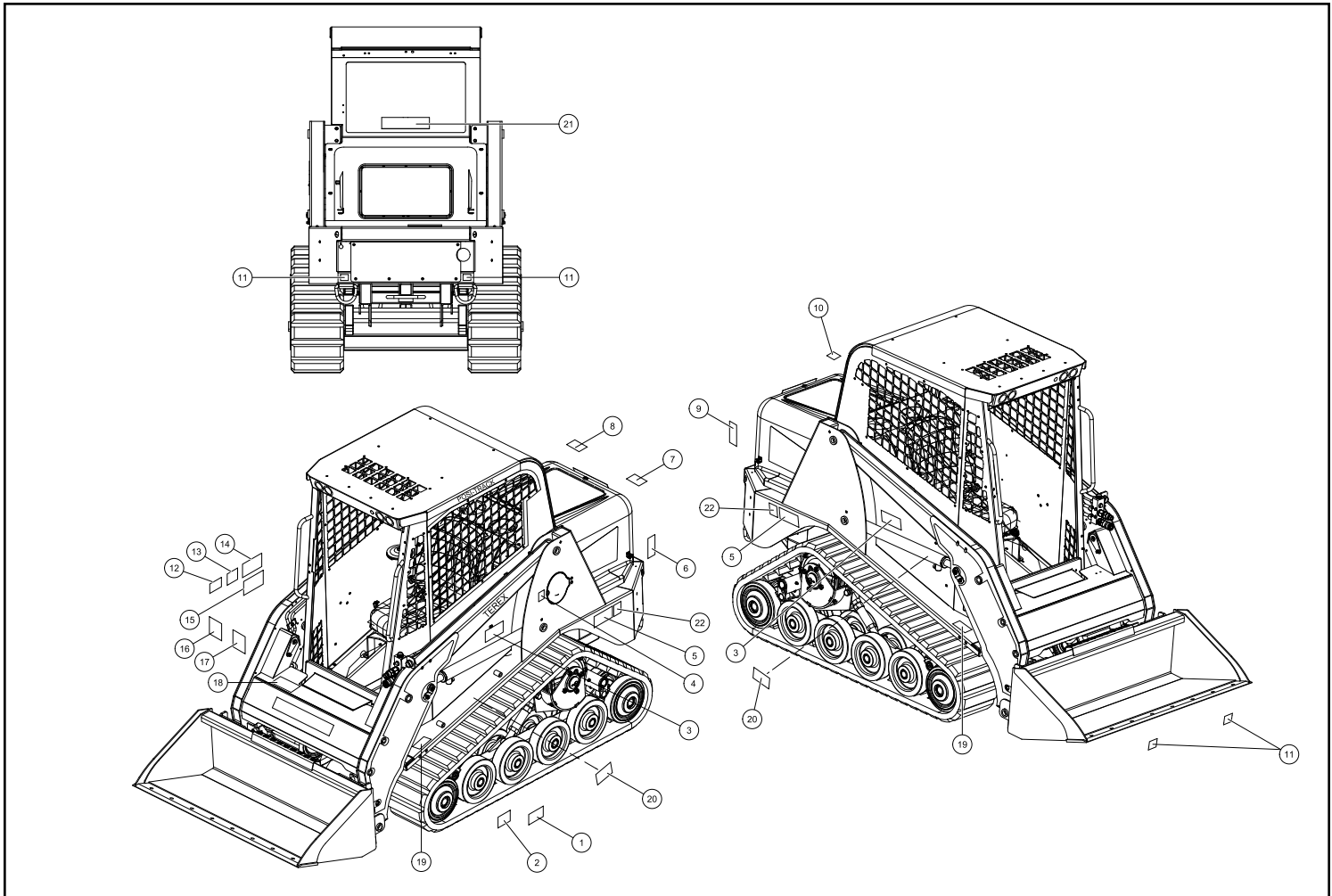

SAFETY DECALS ROW (ISO)

RT-30 valid from - 06870
RO70T valid from - 00101

Charter 9

REF. NO.	PART NUMBER	QTY.	DESCRITION	REF. NO.	PART NUMBER	QTY.	DESCRITION
1	2030-422	1	DECAL,OWNER'S MANUAL				
2	2030-427	1	DECAL BRUSHCUTTING				
3	2030-553	2	DECAL ISO SAFETY SKIN OIL INJECTION				
4	4046-078	1	DECAL DIESEL FUEL ONLY				
5	2030-416	2	DECAL MOVING PARTS (TRACK WARNING)				
6	2030-565	1	DECAL ISO SAFETY BATTERY				
7	2030-418	1	DECAL ENGINE COMPARTMENT				
8	2030-551	1	DECAL ISO SAFETY FAN AND BELT				
9	2030-552	1	DECAL ISO SAFETY EXHAUST HOT				
10	4046-079	1	DECAL CE HYDRAULIC OIL ONLY				
11	0310-197	4	DECAL,TIE DOWN 156-5762				
12	2030-419	1	DECAL THROTTLE (NO TEXT)				
13	2030-428	1	DECAL 2 SPEED				
14	2030-426	1	DECAL NO RIDERS/WORK PLATFORM				
15	2030-420	1	DECAL CARRY LOADS/KEEP INSIDE				
16	2030-424	1	DECAL CONTROLS RIGHT (NO TEXT)				
17	2030-423	1	DECAL CONTROLS LEFT (NO TEXT)				
18	2030-425	1	DECAL 3 POINT (NO TEXT)				
19	2030-415	2	DECAL BOOM CRUSH RT (NO TEXT)				
20	2030-417	2	DECAL LOADER LOCK (NO TEXT)				
21	2010-592	1	DECAL EMERGENCY EXIT ANSI				

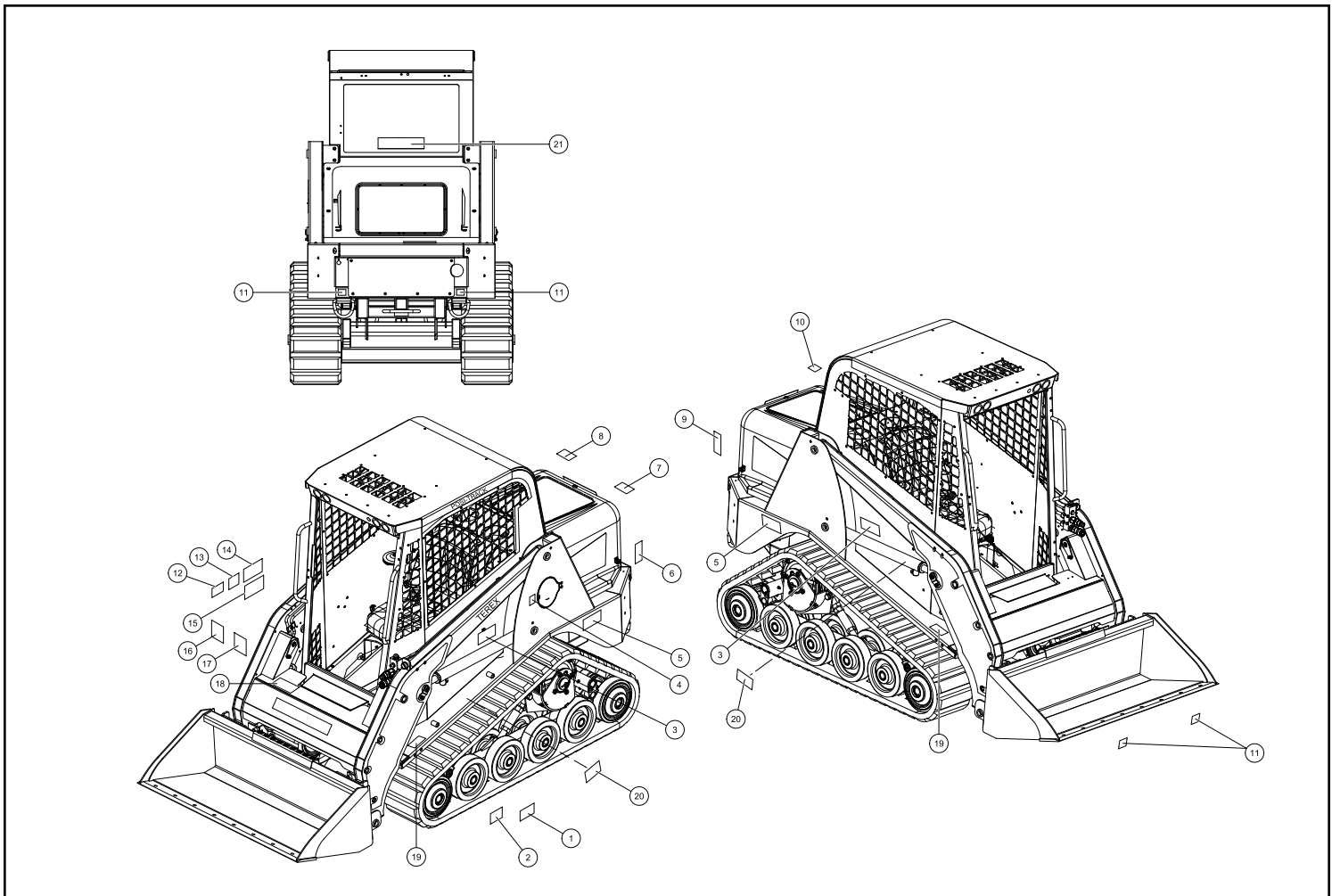

COMPACT POWER EQUIPMENT SAFETY DECALS

RO70T valid from - 00101

Charter 9

REF. NO.	PART NUMBER	QTY.	DESCRIPTION	REF. NO.	PART NUMBER	QTY.	DESCRIPTION
1	0090-637	1	DECAL CPE CHECK OIL				
2	0090-635	1	DECAL CPE REAR HOOD 2X11				
3	0090-639	1	DECAL CPE TIPPING HAZARD				
4	0090-632	2	DECAL CPE RENT ME 3X7				
5	0090-633	2	DECAL CPE RENT ME 4X8				
6	0090-638	1	DECAL CPE CLEANING FEE				
7	0090-640	1	DECAL CPE DIESEL FUEL ONLY				
8	0090-641	1	DECAL CPE DECAL 811				
9	0090-636	1	DECAL CPE CUSTOMER RESPONSIBILITIES				

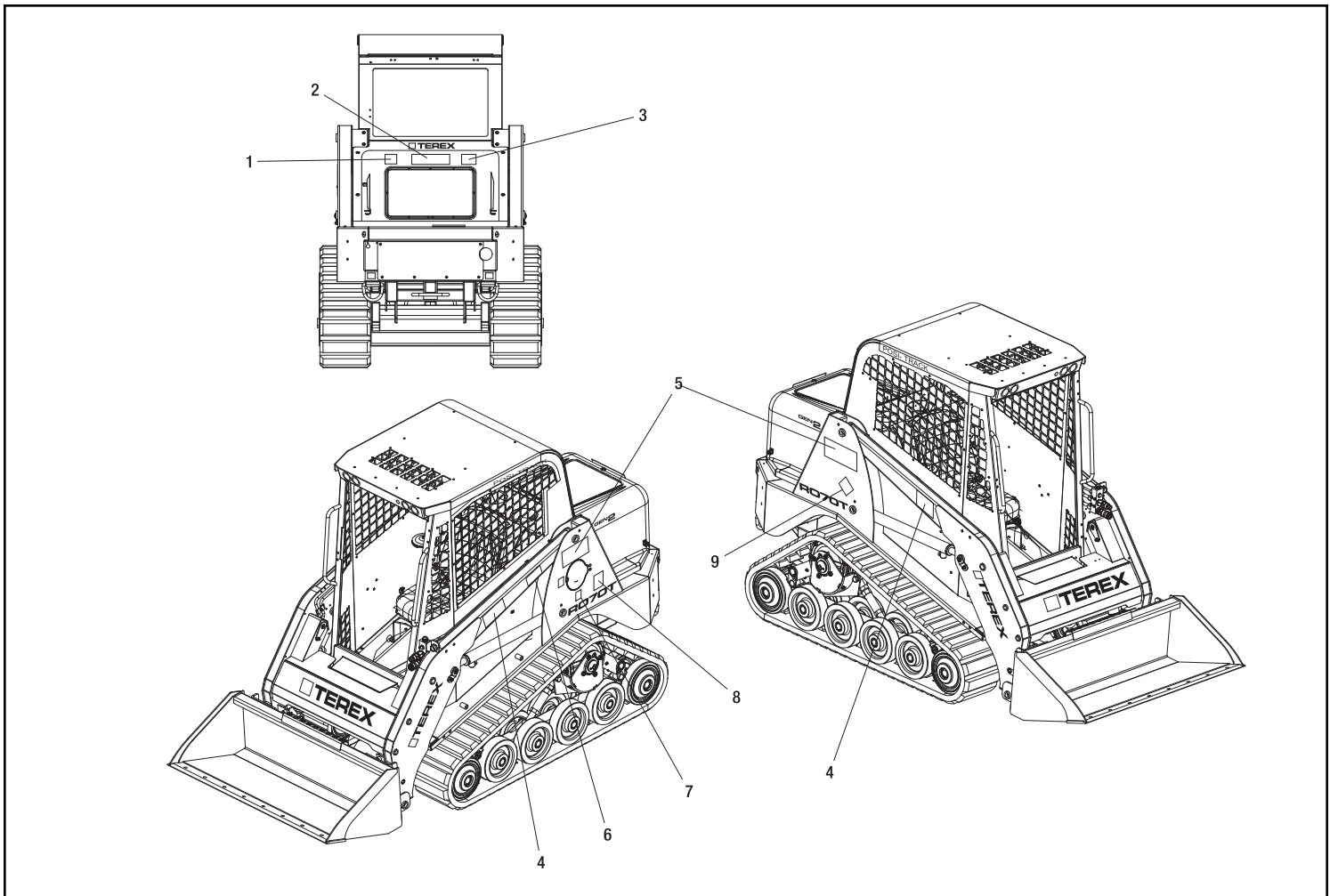

MACHINE GRAPHICS (ASV)

RT-30 valid from - 06870
ASV

Charter 9

REF. NO.	PART NUMBER	QTY.	DESCRITION
1	2030-912	1	DECAL LOADER FRONT
2	2010-867	1	DECAL RT-30 LOADER FRONT LH
3	2010-865	1	DECAL POSI-TRACK LOADER REAR LH
4	2010-883	2	DECAL TOWER ASV
5	2010-864	1	DECAL RT-30 LOADER FRONT RH
6	2010-866	1	DECAL POSI-TRACK LOADER REAR RH

REF. NO.	PART NUMBER	QTY.	DESCRITION

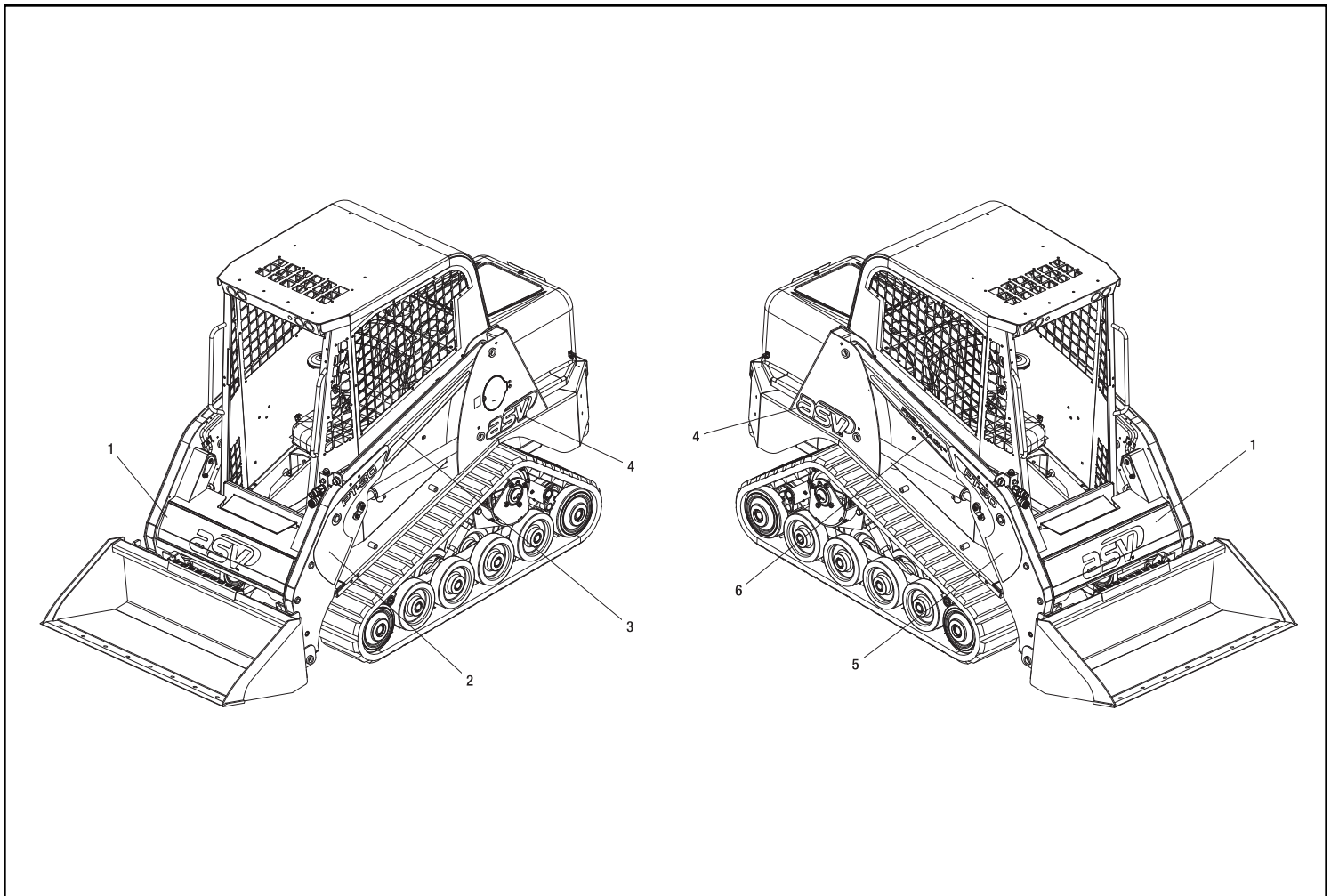

REF. NO.	PART NUMBER	QTY.	DESCRIPTION	REF. NO.	PART NUMBER	QTY.	DESCRIPTION
1	2010-912	1	DECAL LOADER FRONT				
2	2010-882	1	DECAL RT-30 LOADER FRONT LH				
3	2010-880	1	DECAL POSI-TRACK LOADER REAR LH				
4	2010-883	2	DECAL TOWER ASV				
5	2010-881	1	DECAL RT-30 LOADER FRONT RH				
6	2010-879	1	DECAL POSI-TRACK LOADER REAR RH				

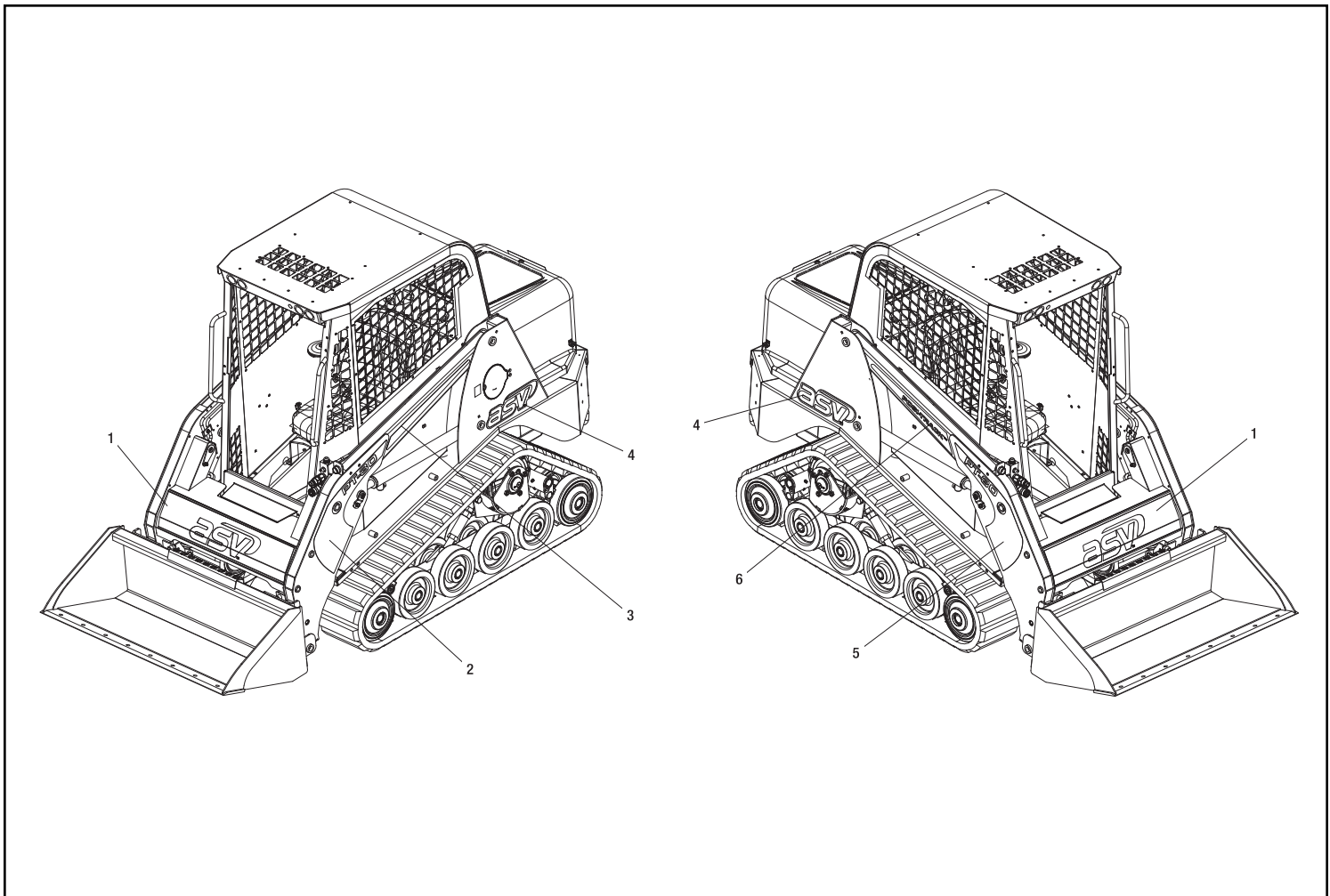

MACHINE GRAPHICS

R070T valid from - 00101
TEREX

Charter 9

REF. NO.	PART NUMBER	QTY.	DESCRIRTION	REF. NO.	PART NUMBER	QTY.	DESCRIRTION
1	2010-261	1	DECAL 1.5" TEREX				
2	2030-334	2	DECAL POSI TRACK				
3	2075-965	2	DECAL LOADER				
4	0090-580	2	DECAL R070T				
5	2030-492	1	DECAL CROSS MEMBER BLACK TEREX				
6	0090-615	2	DECAL GEN 2 BLACK				

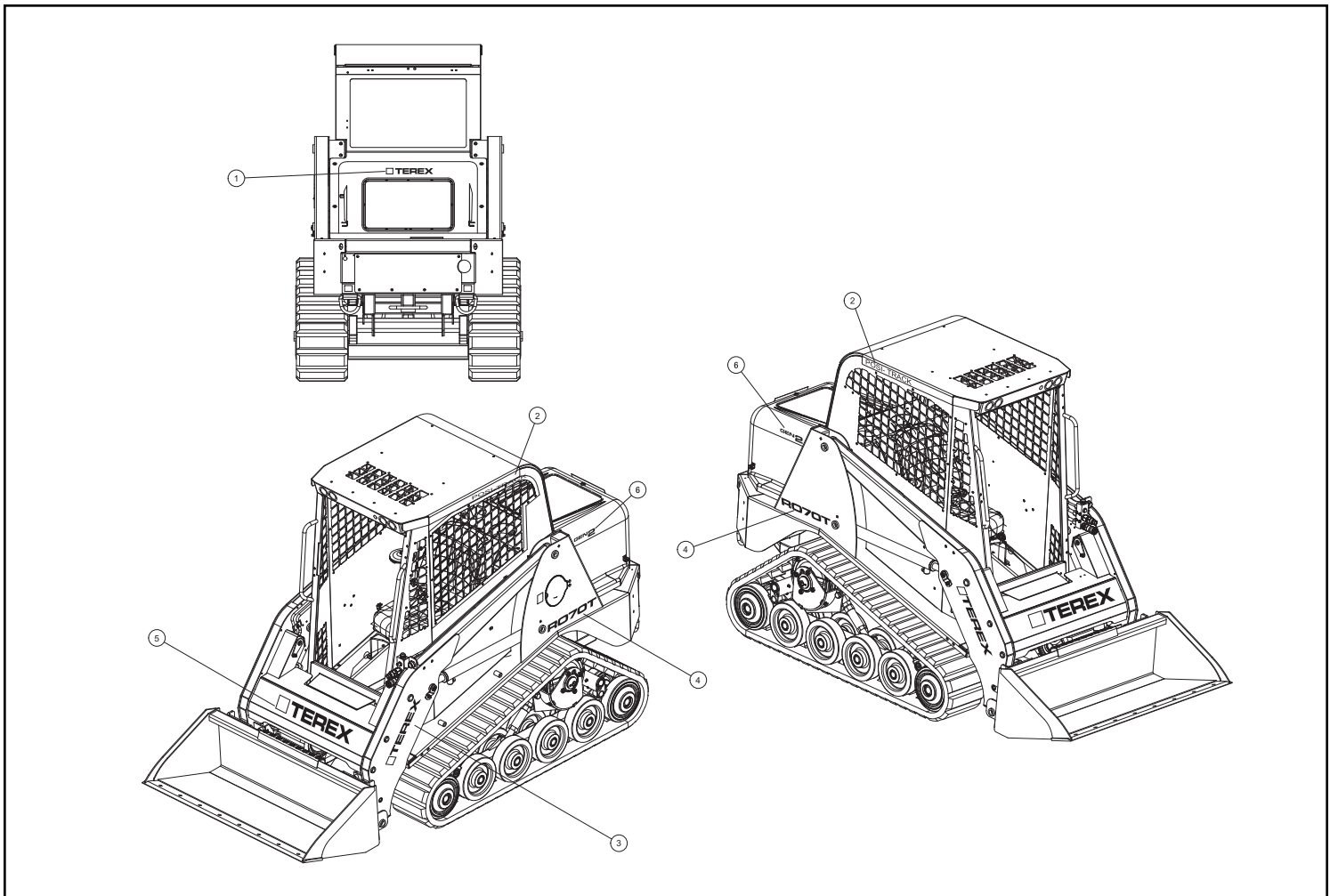



ASV L.L.C.

840 Lily Lane

Grand Rapids MN. 55744

1-800-205-9913