



en **Parts Manual**
MAXI-POWER™ 15XR



www.discount-equipment.com

PARTS FINDER

**Search Website
by Part Number**



**Search Manual
Library For Parts
Manual & Lookup Part
Numbers – Purchase
or Request Quote**

**Can't Find Part or
Manual? Request Help
by Manufacturer,
Model & Description**

Discount-Equipment.com is your online resource for quality parts & equipment.

Florida: **561-964-4949** Outside Florida TOLL FREE: **877-690-3101**

Need parts?

Click on this link: <http://www.discount-equipment.com/category/5443-parts/> and choose one of the options to help get the right parts and equipment you are looking for. Please have the machine model and serial number available in order to help us get you the correct parts. If you don't find the part on the website or on one of the online manuals, please fill out the request form and one of our experienced staff members will get back to you with a quote for the right part that your machine needs.

We sell worldwide for the brands: Genie, Terex, JLG, MultiQuip, Mikasa, Essick, Whiteman, Mayco, Toro Stone, Diamond Products, Generac Magnum, Airman, Haulotte, Barreto, Power Blanket, Nifty Lift, Atlas Copco, Chicago Pneumatic, Allmand, Miller Curber, Skyjack, Lull, Skytrak, Tsurumi, Husquvarna Target, Stow, Wacker, Sakai, Mi-T-M, Sullair, Basic, Dynapac, MBW, Weber, Bartell, Bennar Newman, Haulotte, Ditch Runner, Menegotti, Morrison, Contec, Buddy, Crown, Edco, Wyco, Bomag, Laymor, EZ Trench, Bil-Jax, F.S. Curtis, Gehl Pavers, Heli, Honda, ICS/PowerGrit, IHI, Partner, Imer, Clipper, MMD, Koshin, Rice, CH&E, General Equipment, Amida, Coleman, NAC, Gradall, Square Shooter, Kent, Stanley, Tamco, Toku, Hatz, Kohler, Robin, Wisconsin, Northrock, Oztec, Toker TK, Rol-Air, APT, Wylie, Ingersoll Rand / Doosan, Innovatech, Con X, Ammann, Mecalac, Makinex, Smith Surface Prep, Small Line, Wanco, Yanmar

TABLE OF CONTENTS

1.0 AXLE/TONGUE/OUTRIGGERS

Axle and Wheels	(1.1)
Skid Mount	(1.2)
Fenders	(1.3)
Tongue	(1.4)
Tongue Couplers	(1.5)

2.0 TRAILER BASE PARTS

Engine Cradle	(2.1)
Rear Panel	(2.2)
Stringer	(2.3)
Front Panels with Standard Air Vent Deflectors	(2.4)
Front Panels with Optional Air Vent Covers	(2.5)
Front Cover	(2.6)
Quarters Panels	(2.7)
Doors	(2.8)
Manual Canister	(2.9)

3.0 CONTROL BOX GROUP

Control Box Install Group	(3.1)
Control Box Door	(3.2)
DSE 4520 MK II Control Box Assembly Group	(3.3)
DSE 4520 MK II Fuse Box	(3.4)
DSE L401 Bussman PDM Control Box Assembly Group	(3.5)
DSE L401 Bussman PDM Fuse Box	(3.6)
DSE L401 Chief PDM Control Box Assembly Group	(3.7)
DSE L401 Chief PDM Fuse Box	(3.8)
2-30A RV 2-50A RV NEMA Outlet Package	(3.9)
2-30A Twistlock 2-50A CS6369 Twistlock Outlet Package	(3.10)
2-30A Twistlock 2-50A RV NEMA Outlet Package	(3.11)

MAXI-POWER™ 15XR

TABLE OF CONTENTS

4.0 TRAILER ELECTRICAL

Battery Cables	(4.1)
Battery Disconnect Cables	(4.2)
Battery Charger and Battery Blanket Options	(4.3)
Side Marker Lights and Tail Lights	(4.4)
Breakaway Kit	(4.5)
Emergency Stop	(4.6)

5.0 ENGINE AND FUEL TANK PARTS

Engine Isolator Mounts	(5.1)
Fluid Containment Drain Cap	(5.2)
Fuel Tanks	(5.3)
Fuel Level Sender	(5.4)
Heated Fuel/Water Separator	(5.5)
Radiator Coolant Recovery Tank	(5.6)
Radiator Coolant Drain Group	(5.7)
Radiator Cold Front Group	(5.8)
Oil Drain Group	(5.9)

6.0 CAT C1.5 TURBO ENGINE GROUP

CAT C1.5 Turbo Engine Assembly Group	(6.1)
CAT C1.5 Turbo Engine Fuel Lines	(6.2)
CAT C1.5 Turbo Engine Shocker Group	(6.3)
15kW 1PH Marathon Generator	(6.4)
15kW 1PH Marathon Generator Cord Install Group	(6.5)

7.0 DECAL GROUP

Door Branding Decals	(7.1)
Domestic English Safety Decals	(7.2)
International Wordless Safety Decals	(7.3)
Electrical Decals	(7.4)

1.1 - Axle and Wheels

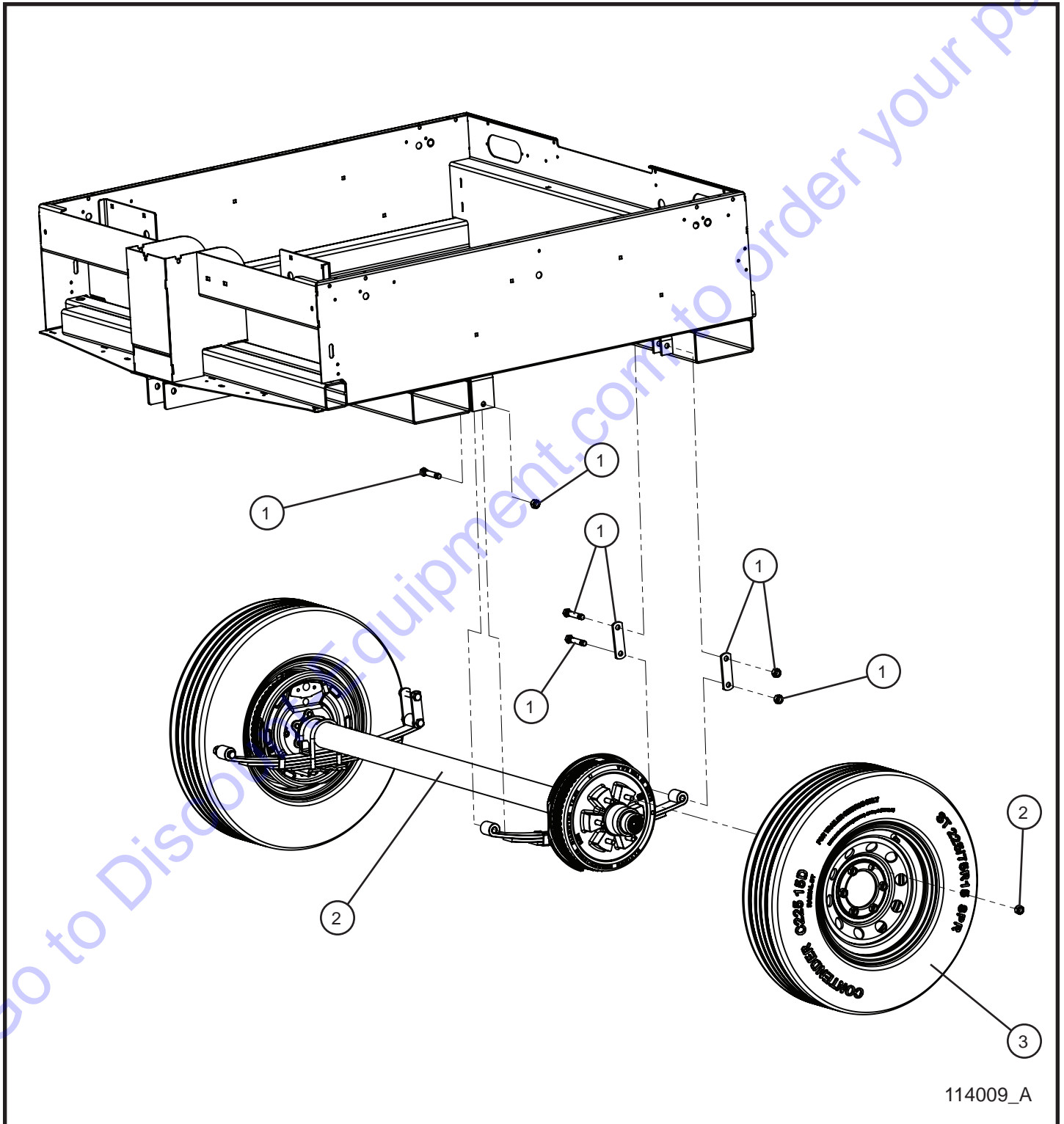

MAXI-POWER™ 15XR

SN 44-000001 and UP

1.1 - Axle and Wheels

Item	Part No.	Part Description	Qty.
1	117120	SUSPENSION KIT SINGLE AXLE	1
2	110278	AXLE 5200LBS ELECTRIC BRAKE MAXI-LITE	1
3	110331	WHEEL-6 BOLT ST225/75R15 LOAD RANGE D	2
NS	022200	1/4 LOOM FLEX GUARD x 23.0	1

*NS - NOT SHOWN

Go to Discount-Equipment.com to order your parts

1.2 - Skid Mount

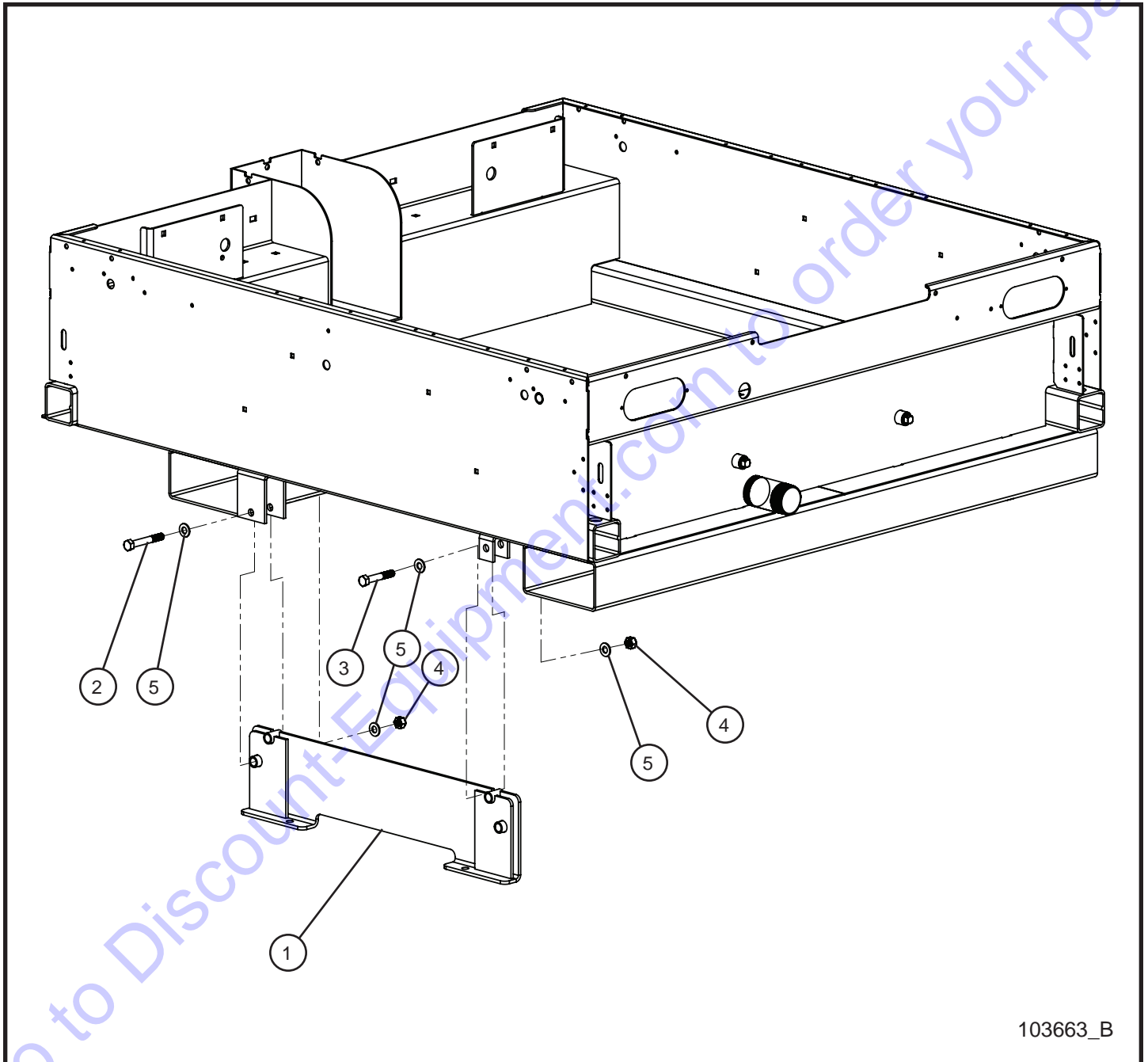

MAXI-POWER™ 15XR

SN 44-000001 and UP

1.2 - Skid Mount

Item	Part No.	Part Description	Qty.
1	113141P	SKID MOUNT MAXI II	2
2	046215	1/2-13 x 3 1/2 HEX HEAD BOLT	2
3	046210	1/2-13 x 3 HEX HEAD BOLT	2
4	044048	1/2-13 NYLOCK HEX NUT	4
5	047025	1/2 FLAT WASHER	8

Go to Discount-Equipment.com to order your parts

1.3 - Fenders

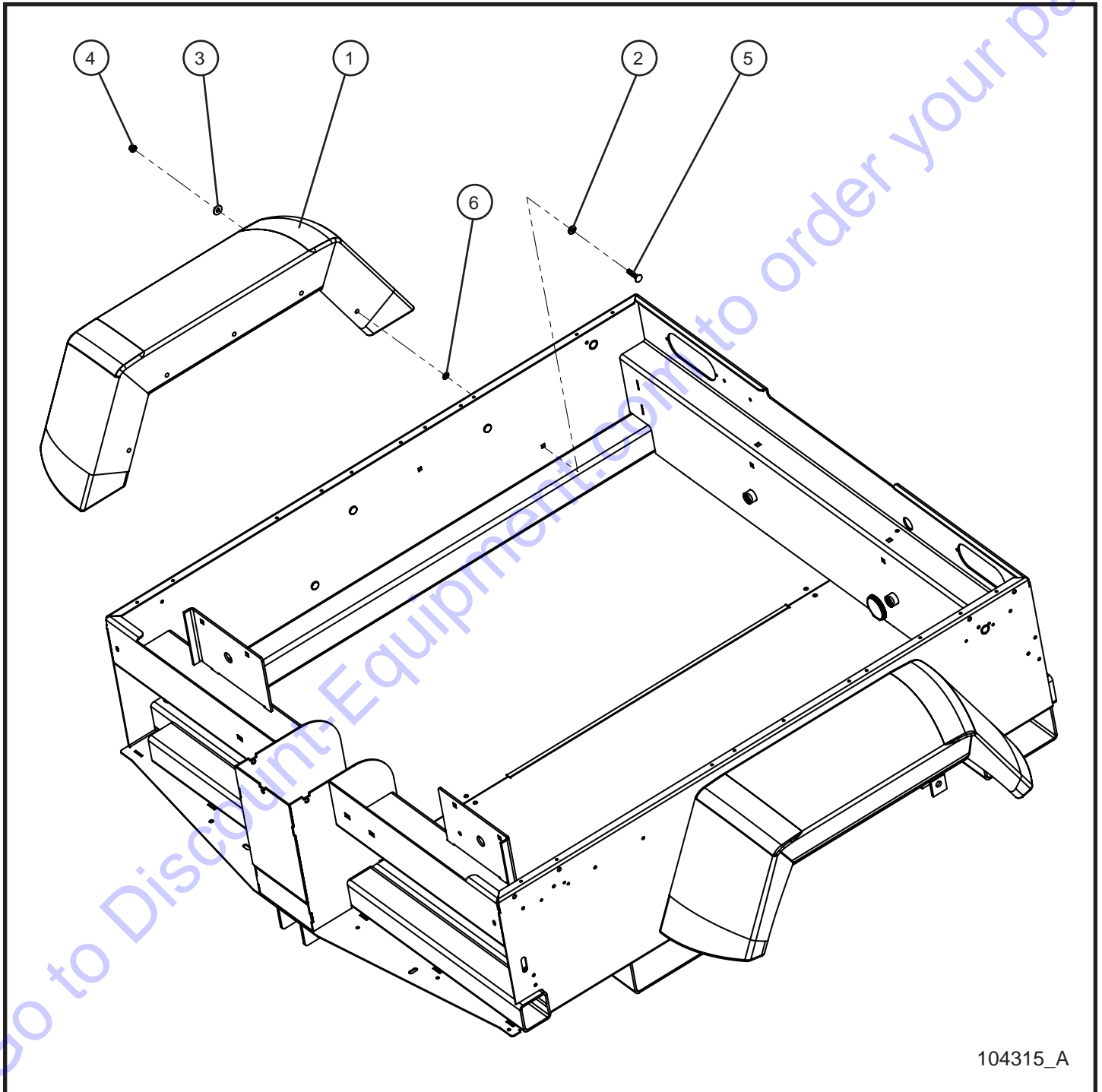

104315_A

MAXI-POWER™ 15XR

SN 44-000001 and UP

1.3 - Fenders

Item	Part No.	Part Description	Qty.
1	103066	FENDER ROTATION MOLDED 15 INCH EMBEDDED DECAL	2
2	100644	RUBBER WASHER BLACK NEOPRENE	8
3	047010	5/16 FLAT WASHER PL	8
4	044031	5/16-18 KEPS HEX NUT PL	8
5	053023	5/16-18 x 1 1/2 CARRIAGE BOLT PL	8
6	045217	5/16 PUSH NUT	8

Go to Discount-Equipment.com to order your parts

1.4 - Tongue

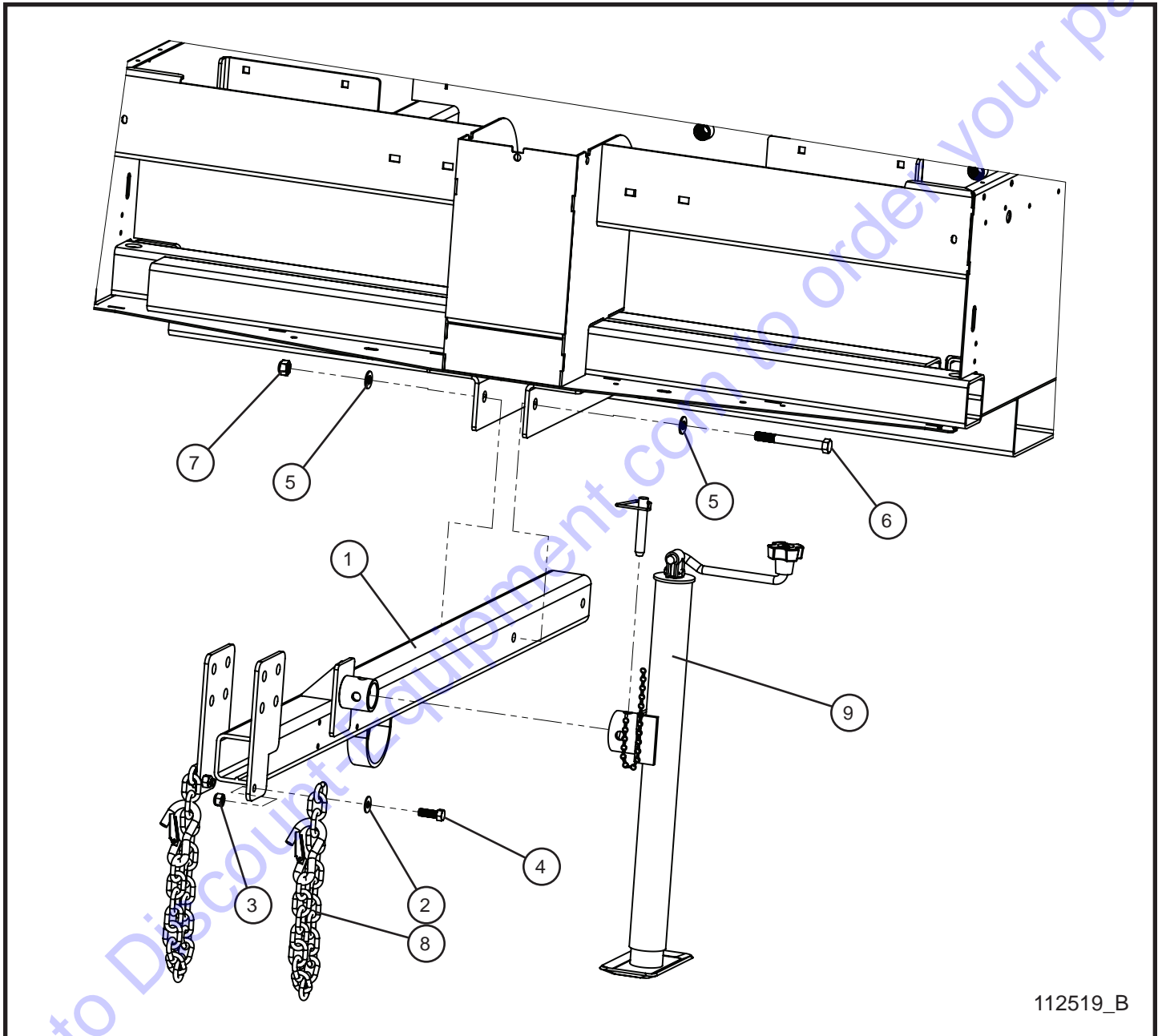

112519_B

MAXI-POWER™ 15XR

SN 44-000001 and UP

1.4 - Tongue

Item	Part No.	Part Description	Qty.
1	112377P	TONGUE WELDMENT REVERSIBLE COUPLER	1
2	047015	3/8 FLAT WASHER	2
3	044043	7/16-14 NYLOCK HEX NUT	2
4	046159	7/16-14 x 1 1/4 HEX HEAD BOLT	2
5	047025	1/2 FLAT WASHER	4
6	046225	1/2-13 x 4 1/2 HEX HEAD BOLT	2
7	044048	1/2-13 NYLOCK HEX NUT	2
8	049040	SAFETY CHAIN	2
9	108727	TOP CRANK JACK TUBE MOUNT	2

Go to Discount-Equipment.com to order your parts

1.5 - Tongue Couplers

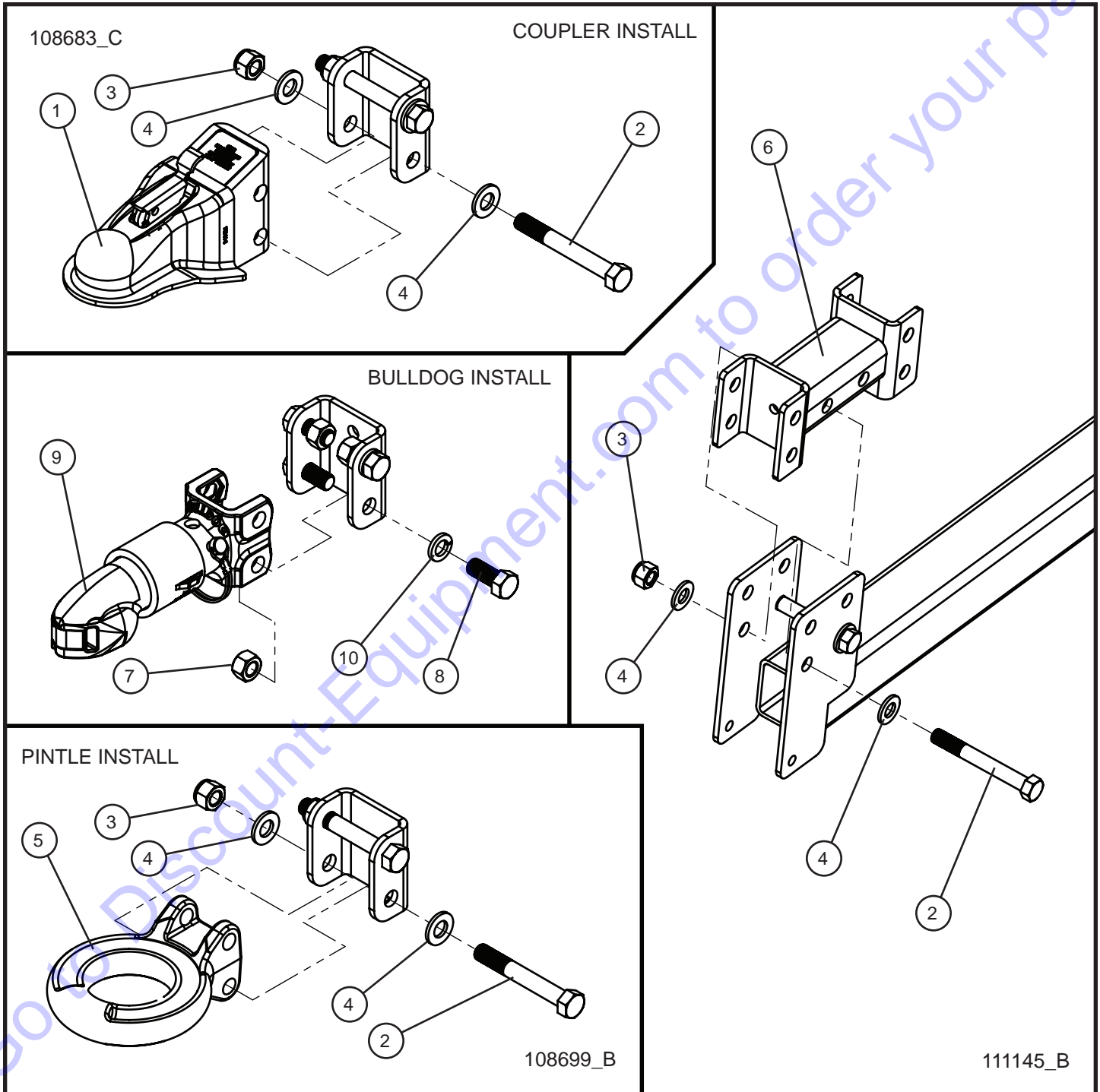

MAXI-POWER™ 15XR

SN 44-000001 and UP

1.5 - Tongue Couplers

Item	Part No.	Part Description	Qty.
1	109977	COUPLER BALL 2.00 ADJUSTABLE STAMPED	1
	109976	COUPLER BALL 2.313 ADJUSTABLE STAMPED	1
2	046255	5/8-11 x 5 HEX HEAD BOLT	4
3	044053	5/8-11 NYLOCK HEX NUT	4
4	047031	5/8 FLAT WASHER	10
5	106720	RING PINTLE 3.00 ADJUSTABLE	1
6	111148P	REVERSIBLE COUPLER TONGUE MOUNT	1
7	044050	5/8-11 HEX NUT	4
8	046245	5/8-11 x 1 1/2 HEX HEAD BOLT	4
9	109978	COUPLER BALL 2.00 BULLDOG HITCH 7,000 LBS	1
	109979	COUPLER BALL 2.313 BULLDOG HITCH 12,500 LBS	1
10	043101	5/8 SPLITLOCK WASHER	4

Go to Discount-Equipment.com to order your parts

2.1 - Engine Cradle

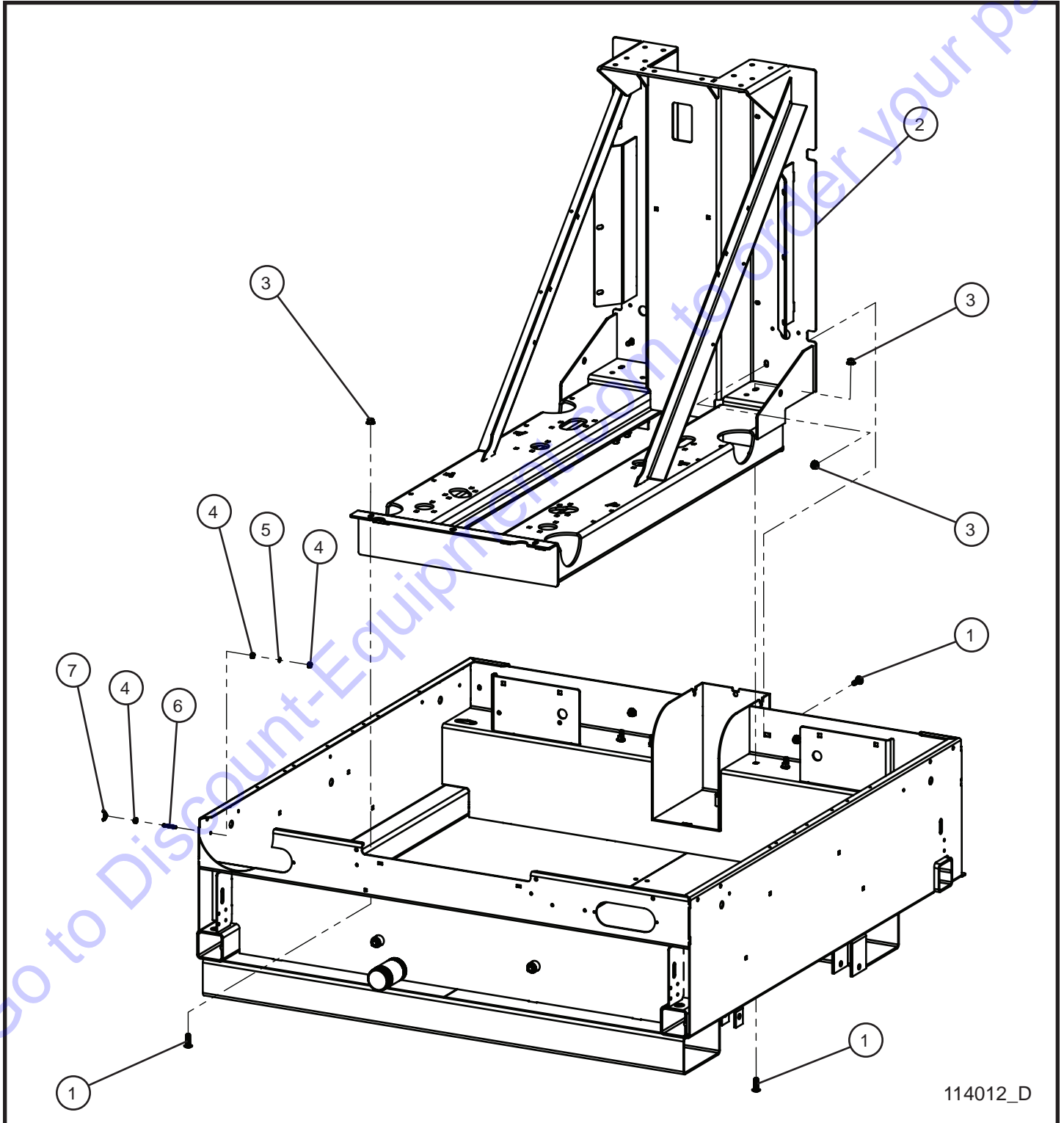

MAXI-POWER™ 15XR

SN 44-000001 and UP

2.1 - Engine Cradle

Item	Part No.	Part Description	Qty.
1	100670	3/8-16 x 1 1/4 CARRIAGE BOLT	22
2	120060P	ENGINE CRADLE REINFORCED MAXI-LITE II	1
3	044029	3/8-16 SERRATED FLANGLE NUT	22
4	044021	1/4-20 KEPS HEX NUT	3
5	043050	1/4 INTERNAL TOOTH LOCK WASHER	1
6	045003	1/4-20 x 1-1/2 STUD	1
7	330494	1/4-20 WING NUT	1

Go to Discount-Equipment.com to order your parts

2.2 - Rear Panel

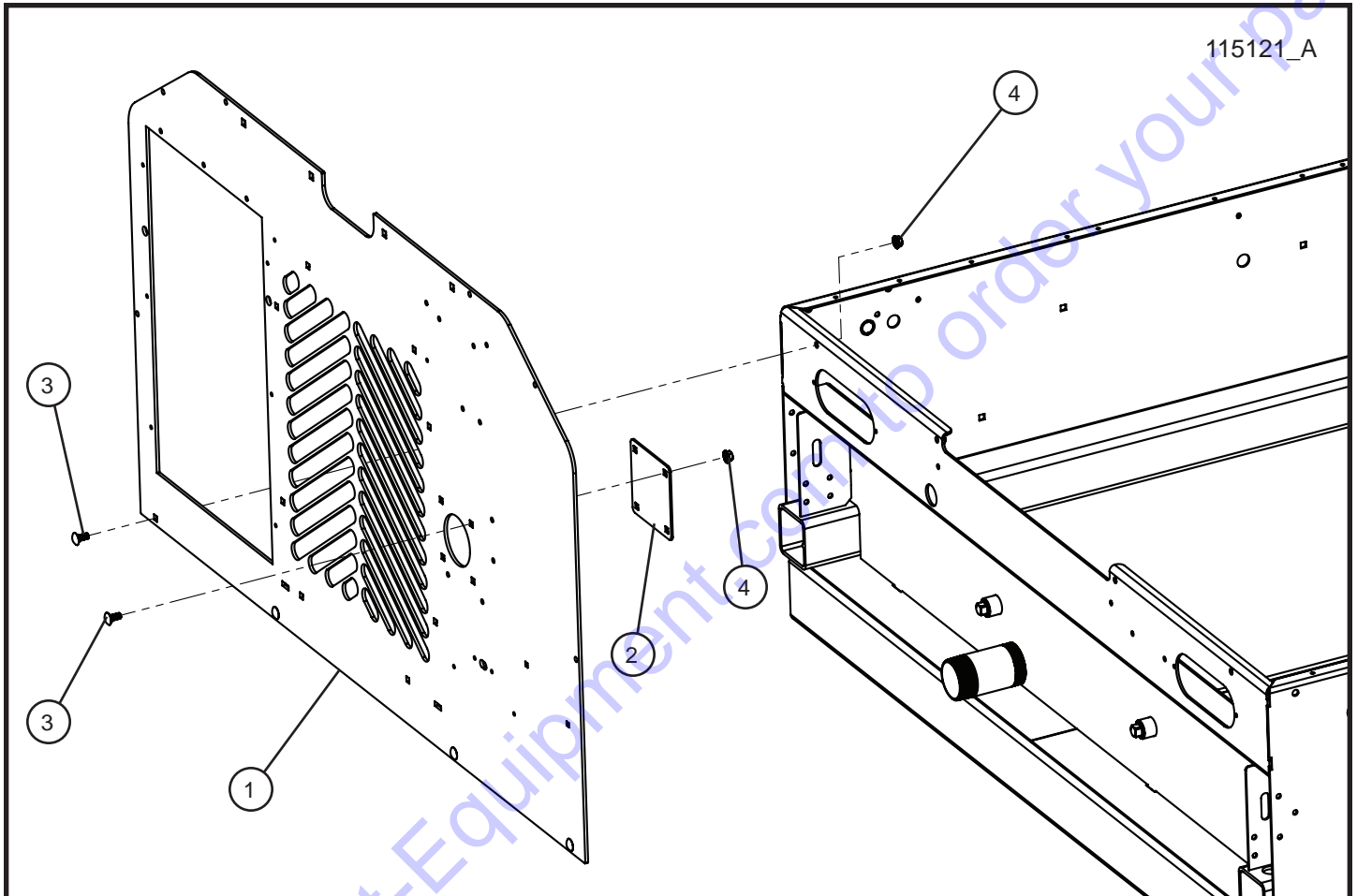

MAXI-POWER™ 15XR

SN 44-000001 and UP

2.2 - Rear Panel

Item	Part No.	Part Description	Qty.
1	115161P	STANDARD RADIATOR MOUNTED REAR PANEL	1
2	106250P	STANDARD MUFFLER HOLE PLATE	1
3	102081	5/16-18 x 3/4 CARRIAGE BOLT	8
4	057006	5/16-18 SERRATED FLANGE NUT	8

Go to Discount-Equipment.com to order your parts

2.3 - Stringer

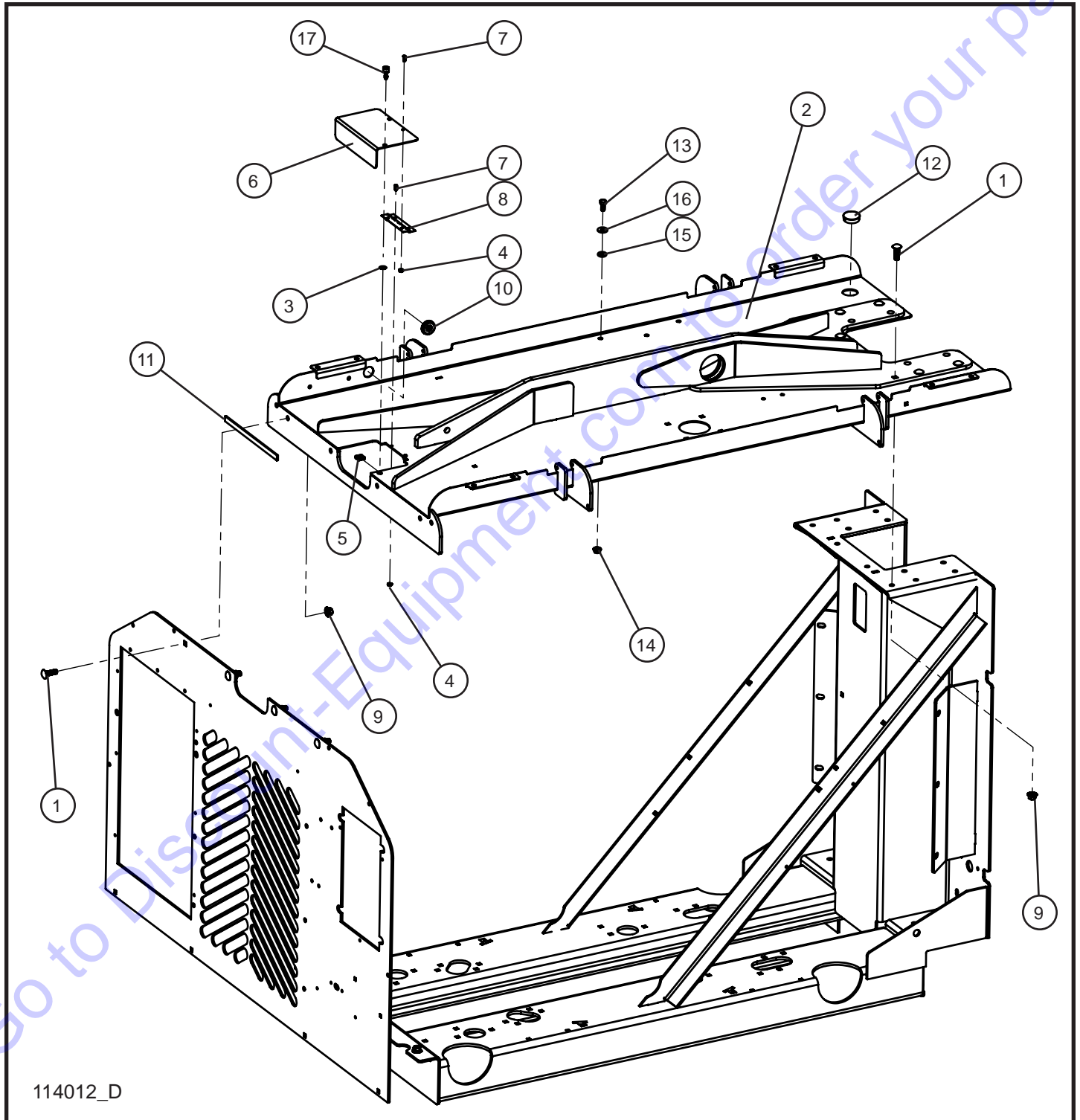

114012_D

MAXI-POWER™ 15XR

SN 44-000001 and UP

2.3 - Stringer

Item	Part No.	Part Description	Qty.
1	100670	3/8-16 x 1 1/4 CARRIAGE BOLT	22
2	113415P	STRINGER WELDMENT 15/20kW MAXI II	1
3	115243	RETAINER PUSH ON	1
4	044004	#6-32 KEPS HEX NUT	4
5	045216	1/4-20 TINNERMAN NUT	1
6	109871P	RADIATOR CAP ACCESS PANEL	1
7	041259	#6-32 x 1/2 PH-FLAT HEAD MACHINE SCREW	4
8	045023	HINGE CONTROLLER COVER	1
9	044029	3/8-16 SERRATED FLANGE NUT	22
10	100859	7/8 ID x 1 1/4 OD GROMMET	1
11	115259	SEAL 1/8 x 1/2 x 9.5	1
12	108911	LOCKING DOME	1
13	046045	5/16-18 x 3/4 HEX HEAD BOLT	3
14	057006	5/16-18 SERRATED FLANGE NUT	3
15	100644	RUBBER WASHER	3
16	047010	5/16 FLAT WASHER	3
17	115244	FAST THREAD KNURLED KNOB	1

2.4 - Front Panels with Standard Air Vent Deflectors

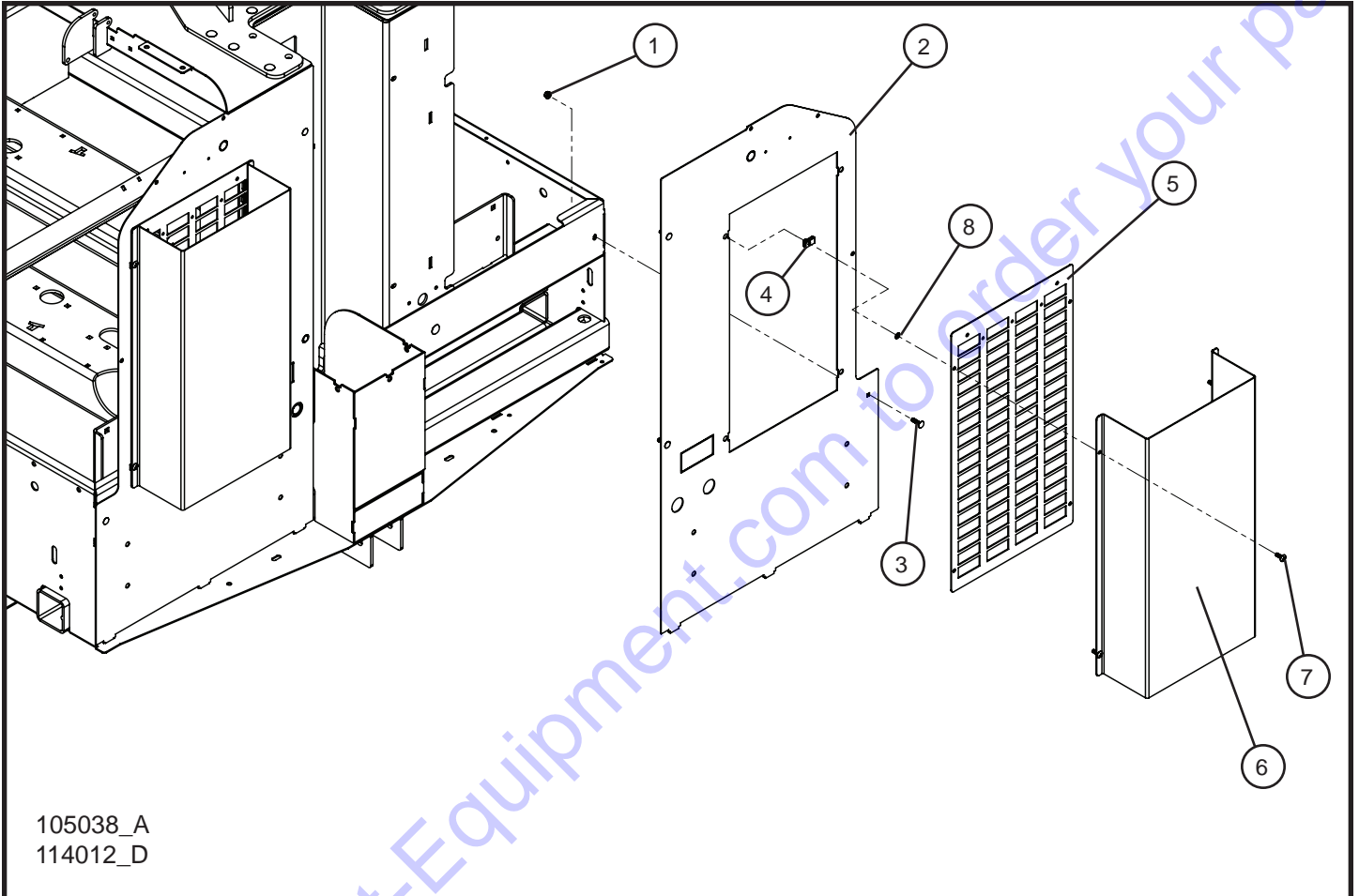

MAXI-POWER™ 15XR

SN 44-000001 and UP

2.4 - Front Panels with Standard Air Vent Deflectors

Item	Part No.	Part Description	Qty.
1	057001	1/4-20 HEX NYLOCK FLANGE NUT	6
2	115139P	MULTI OPTION FRONT PANEL MAXI II	2
3	100342	1/4-20 x 1 CARRIAGE BOLT	6
4	044106	1/4-20 TINNERMAN NUT	8
5	104800P	PLATE AIR VENT GRID MAXI II	2
6	104799P	AIR VENT DEFLECTORS MAXI II (SPECIFY CHIP RESISTANT)	2
7	041050	1/4-20 x 3/4 PH-TRUSS HEAD MACHINE SCREW	8
8	101701	1/4 PUSH NUT	8

Go to Discount-Equipment.com to order your parts

2.5 - Front Panels with Optional Air Vent Covers

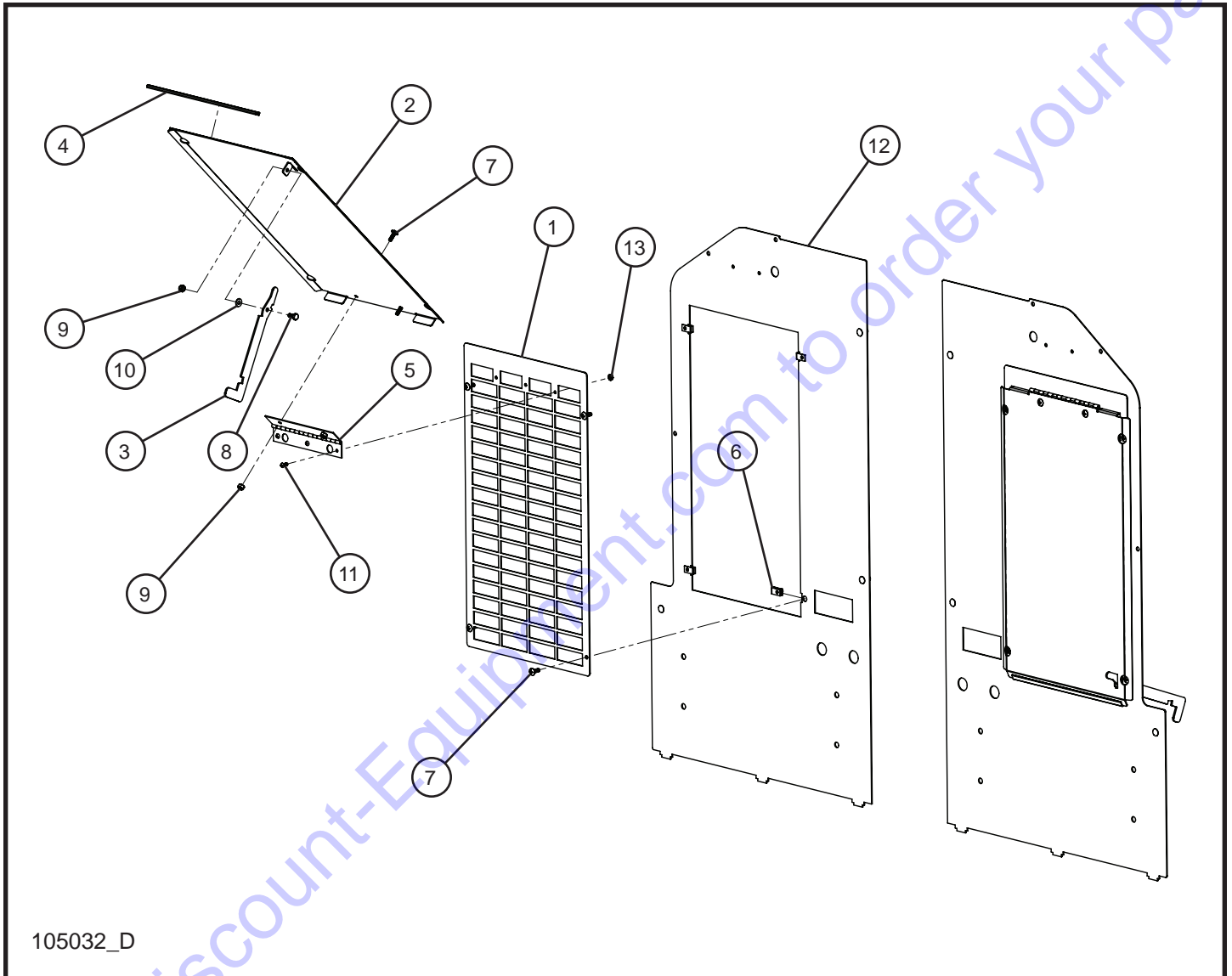

MAXI-POWER™ 15XR

SN 44-000001 and UP

2.5 - Front Panels with Optional Air Vent Covers

Item	Part No.	Part Description	Qty.
1	104800P	PLATE AIR VENT GRID MAXI II	2
2	105001P	SOLID COVER DOOR AIR INLET MAXI II	2
3	105029P	LOCK PLATE SOLID COVER	2
4	030053	5/64 x 7/16 TRIM LOCK 12 INCH	2
5	105028	COVER HINGE AIR INTAKE	2
6	044106	1/4-20 TINNEMAN NUT	8
7	041050	1/4-20 x 3/4 PH-TRUSS HEAD MACHINE SCREW	8
8	046006	1/4-20 x 5/8 HEX HEAD BOLT	2
9	044023	1/4-20 NYLOCK HEX NUT	6
10	047009	1/4 FLAT WASHER	2
11	041021	#10-24 x 1/2 PH-ROUND HEAD MACHINE SCREW	6
12	115139P	MULTI OPTION FRONT PANEL MAXI II	2
13	044016	#10-24 KEPS HEX NUT	6

Go to Discount-Equipment.com to order your parts

2.6 - Front Cover

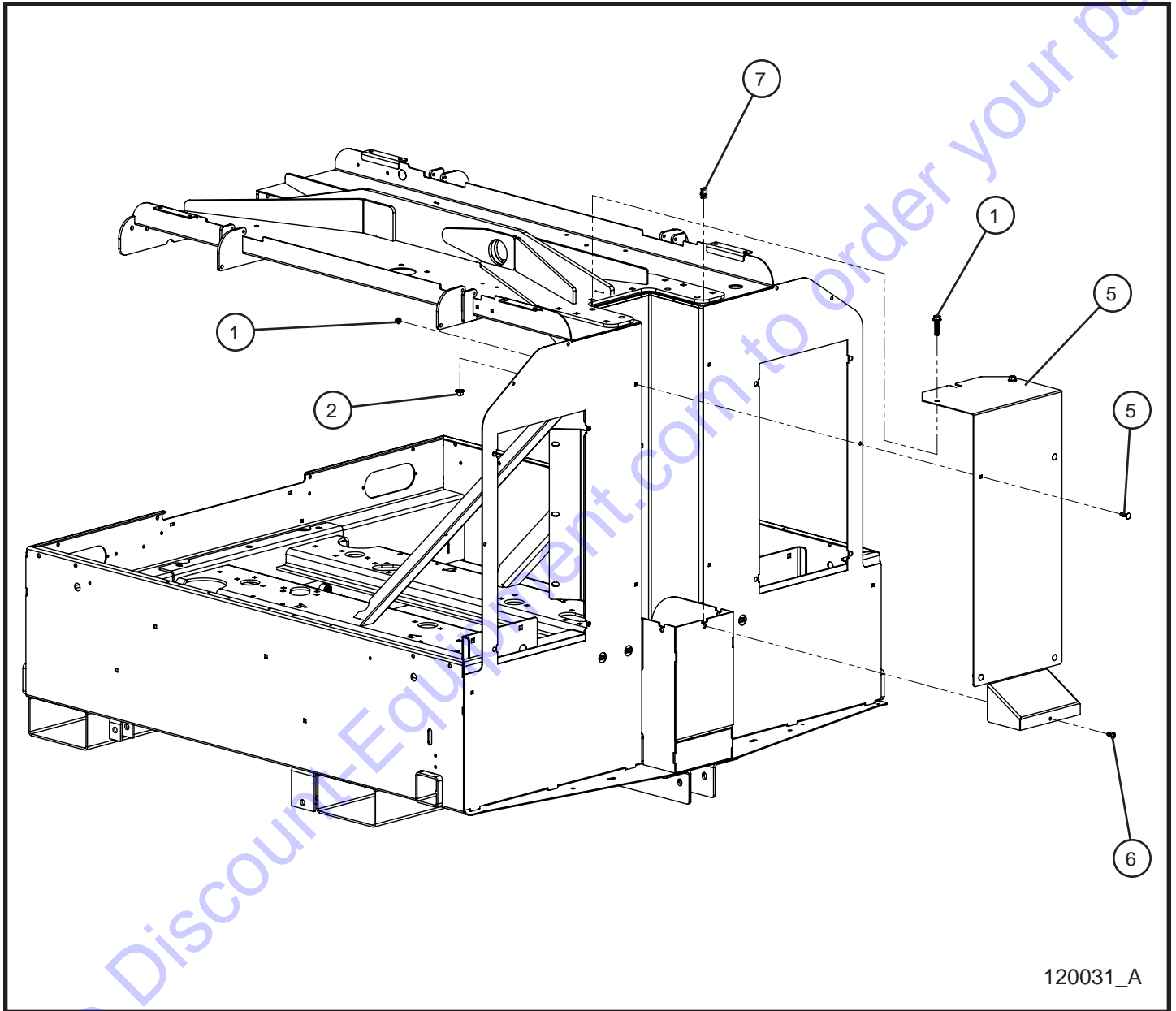

MAXI-POWER™ 15XR

SN 44-000001 and UP

2.6 - Front Cover

Item	Part No.	Part Description	Qty.
1	056015	3/8-16 x 1 1/2 HEX FLANGE SCREW	2
2	044029	3/8-16 SERRATED FLANGE NUT	2
3	100342	1/4-20 x 1 CARRIAGE BOLT	4
4	057001	1/4-20 HEX NYLOCK FLANGE NUT	4
5	041050	1/4-20 x 3/4 PH-TRUSS HEAD MACHINE SCREW	1
6	044106	1/4-20 NUT U EXTRUDED	1
7	120032P	COVER MAXI-POWER 15XR	1

Go to Discount-Equipment.com to order your parts

2.7 - Quarter Panels

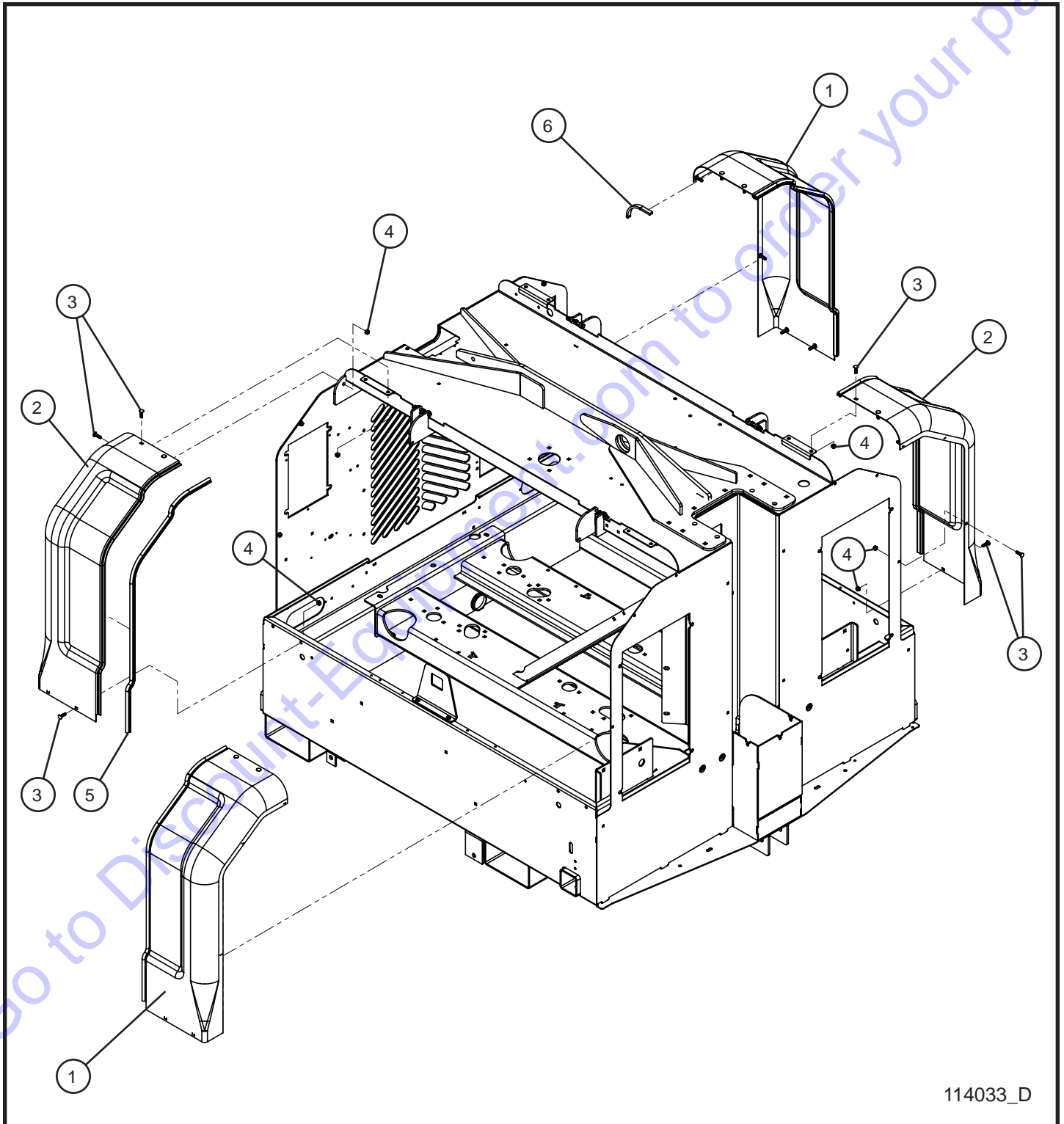

114033_D

MAXI-POWER™ 15XR

SN 44-000001 and UP

2.7 - Quarter Panels

Item	Part No.	Part Description	Qty.
1	103642P	PANEL QUARTER LEFT REAR/RIGHT FRONT	2
2	103643P	PANEL QUARTER LEFT FRONT/RIGHT REAR	2
3	100342	1/4-20 x 1 CARRIAGE BOLT	28
4	057001	1/4-20 HEX NYLOCK FLANGE NUT	28
5	105998	TRIM GASKET 1/16" x 41" WITH 3/8 BULB	4
6	115260	SEAL 1/4 x 1/2 x 5.5	4

Go to Discount-Equipment.com to order your parts

2.8 - Doors

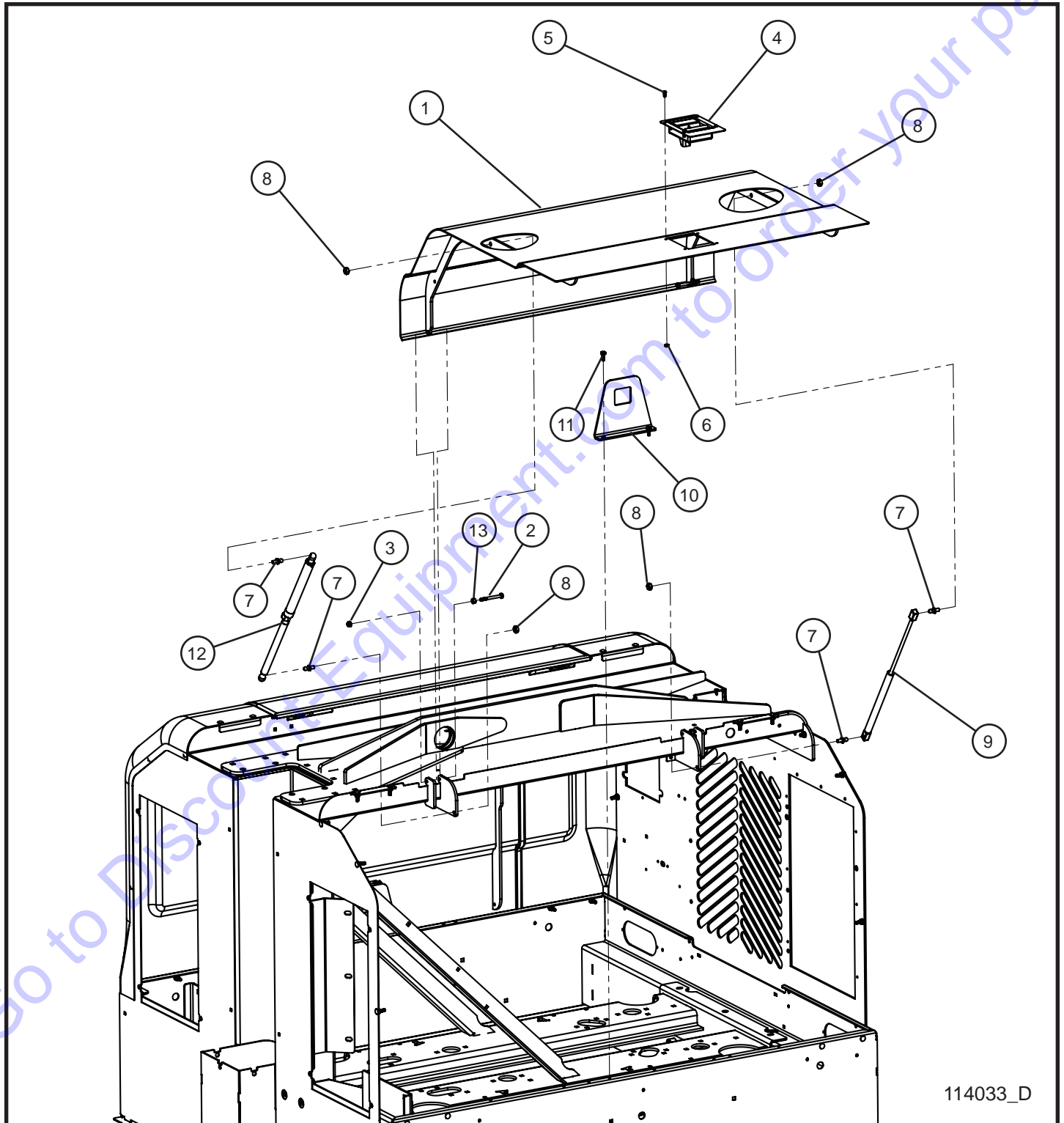

MAXI-POWER™ 15XR

SN 44-000001 and UP

2.8 - Doors

Item	Part No.	Part Description	Qty.
1	104540P	MAXI II DOOR	2
2	046036	1/4-20 x 2 1/2 HEX HEAD BOLT	4
3	057001	1/4-20 HEX NYLOCK FLANGE NUT	32
4	680459	SLAM LATCH	2
5	041021	#10-24 x 1/2 PH-ROUND HEAD MACHINE SCREW	8
6	044018	#10-24 NYLOCK HEX NUT	8
7	330437	BALL STUD M10	8
8	044090	5/16-18 TOP LOCK HEX NUT	8
9	680813	LIFT SUPPORT	2
10	104313P	BRACKET DOOR SLAM LATCH	2
11	041070	1/4-20 x 3/4 SL-HEX WASHER HEAD MACHINE SCREW	4
12	105245	CYLINDER GAS SPRING LOCKING	2
13	105362	COLLAR LOCKING .25 ID	4

Go to Discount-Equipment.com to order your parts

2.9 - Manual Canister

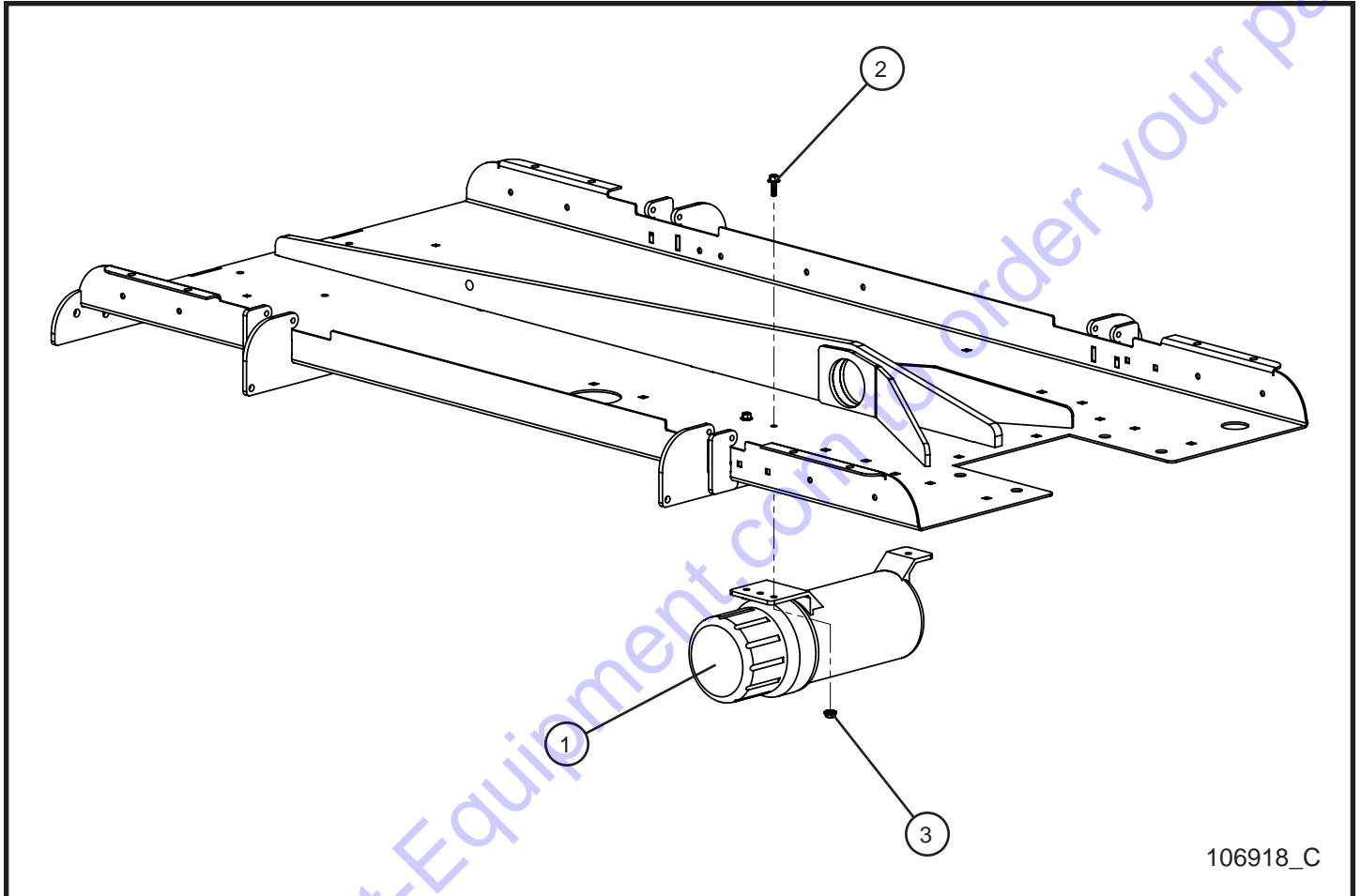

106918_C

MAXI-POWER™ 15XR

SN 44-000001 and UP

2.9 - Manual Canister

Item	Part No.	Part Description	Qty.
1	106916	MEGA CANISTER	1
2	056002	1/4-20 x 3/4 HEX SERRATED FLANGE SCREW	3
3	057000	1/4-20 HEX SERRATED FLANGE NUT	3
NS	118348	OPERATOR'S MANUAL MAXI-POWER 15XR	4

Go to Discount-Equipment.com to order your parts

3.1 - Control Box Install Group

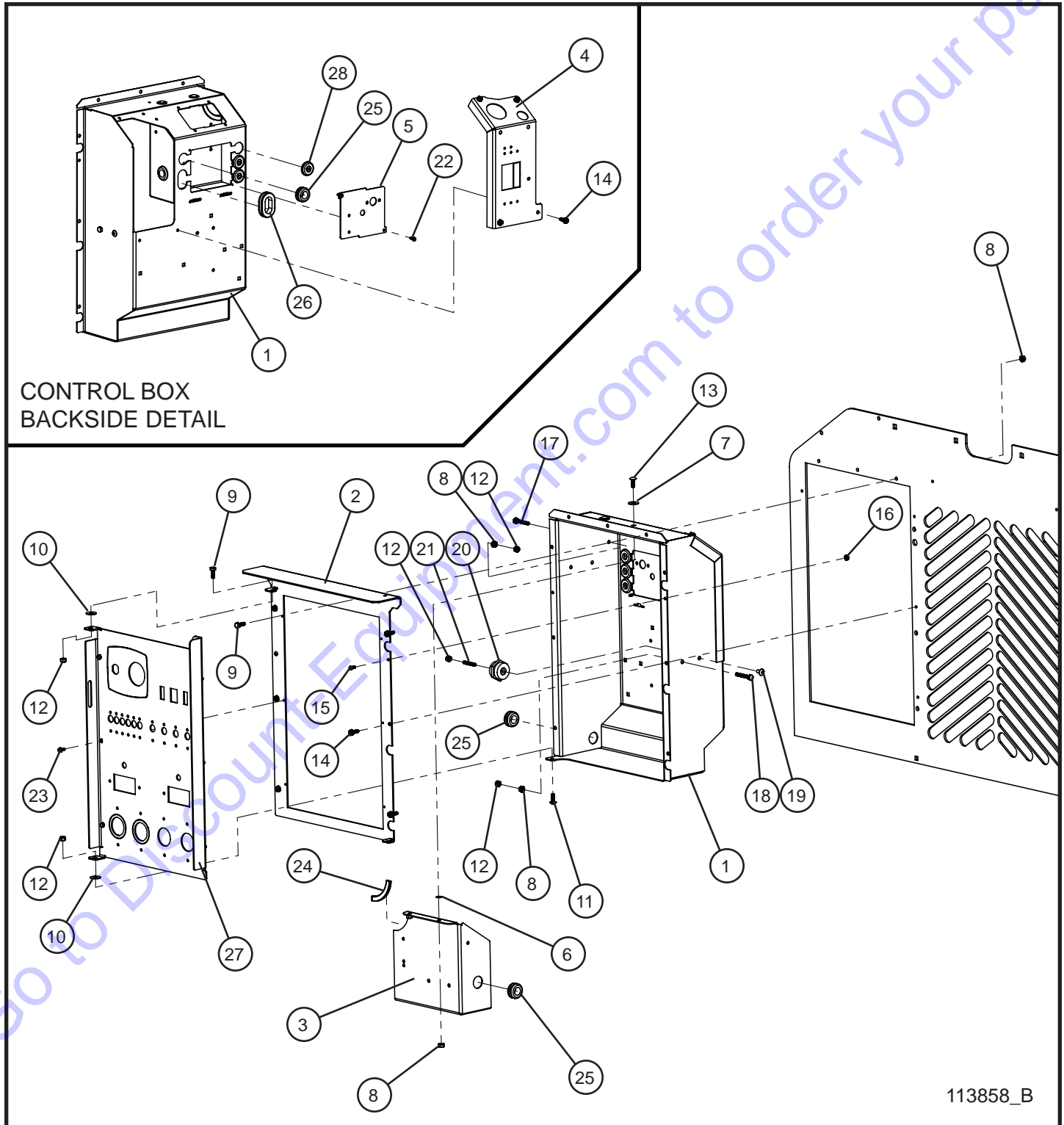

113858_B

MAXI-POWER™ 15XR

SN 44-000001 and UP

3.1 - Control Box Install Group

Item	Part No.	Part Description	Qty.
1	111222P	MAXI-LITE COMPONENT BOX SHELL	1
2	113480P	MAXI-LITE COMPONENT BOX DOOR MOUNT	1
3	111227P	MAXI-LITE COMPONENT BOX DIVIDER PANEL	1
4	112434P	MAXI-LITE MAIN BREAKER PANEL	1
5	111228P	MAXI-LITE COMPONENT BOX BACK COVER	1
6	101701	1/4 PUSH NUT	2
7	047010	5/16 FLAT WASHER	2
8	044021	1/4-20 KEPS HEX NUT	7
9	046010	1/4-20 x 3/4 HEX HEAD BOLT	4
10	711036	3/8 NYLON WASHER 7/8 OD x 11/32 ID	3
11	041050	1/4-20 x 3/4 PH-TRUSS HEAD MACHINE SCREW	3
12	044023	1/4-20 NYLON HEX NUT	7
13	053006	1/4-20 x 3/4 CARRIAGE BOLT	2
14	041070	1/4-20 x 3/4 SL-HEX WASHER HEAD MACHINE SCREW	10
15	041021	#10-24 x 1/2 PH-ROUND HEAD MACHINE SCREW	10
16	044016	#10-24 KEPS HEX NUT	2
17	046016	1/4-20 x 1-1/4 HEX HEAD BOLT	1
18	046029	1/4-20 x 1-3/4 HEX HEAD BOLT	1
19	122452	1/4-20 X 1/2 HEX SERRATED FLANGE BOLT W/ THREAD LOCK	1
20	106318	1/4-20, 1-1/4" LOW VOLTAGE INSULATOR	1
21	122454	1/4-20 X 1-1/2 STUD W/ THREAD LOCK	1
22	041029	#8-32 x 1/2 HEX WASHER HEAD MACHINE SCREW	2
23	041031	#10-24 x 1/2 HEX HEAD MACHINE SCREW	6
24	030053	5/64 x 7/16 x 2 7/8 TRIMLOCK	1
25	330463	11/16 ID x 1 OD GROMMET	3
26	650542	1 1/4 ID x 1 1/2 OD GROMMET	1
27	112565P	MAXI-LITE COMPONENT BOX DSE 4520 MK II OUTLET PANEL	1
28	100859	7/8 ID x 1 1/4 OD WEBBED GROMMET	3

3.2 - Control Box Door

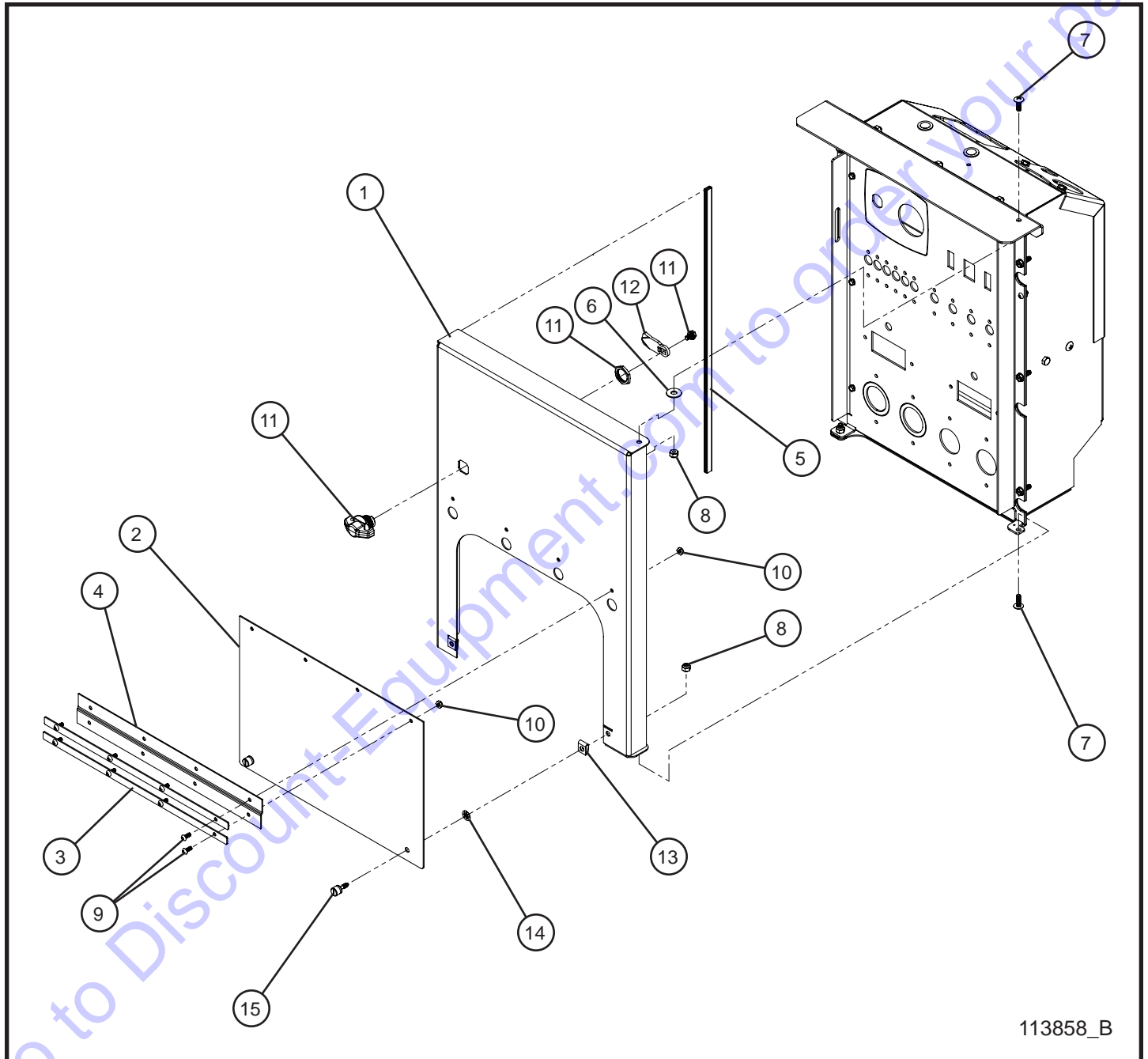

MAXI-POWER™ 15XR

SN 44-000001 and UP

3.2 - Control Box Door

Item	Part No.	Part Description	Qty.
1	111226P	MAXI-LITE COMPONENT BOX DOOR PANEL	1
2	112431P	MAXI-LITE COMPONENT BOX DOOR FLAP	1
3	112433P	MAXI-LITE COMPONENT BOX HINGE STRAP	2
4	115115	HINGE	1
5	030053	5/64 x 7/16 x 20 TRIMLOCK	1
6	711036	3/8 NYLON WASHER 7/8 OD x 11/32 ID	3
7	041050	1/4-20 x 3/4 PH-TRUSS HEAD MACHINE SCREW	3
8	044023	1/4-20 NYLOCK HEX NUT	7
9	041021	#10-24 x 1/2 PH-ROUND HEAD MACHINE SCREW	10
10	044018	#10-24 NYLOCK HEX NUT	8
11	111481	PADLOCKABLE BLACK WINGKNOB	1
12	111482	LATCH CAM STRAIGHT	1
13	045216	1/4-20 TINNEMAN NUT	1
14	115243	RETAINER PUSH ON	2
15	115244	FAST THREAD KNURLED KNOB	2

Go to Discount-Equipment.com to order your parts

3.3 - DSE 4520 MK II Control Box Assembly Group

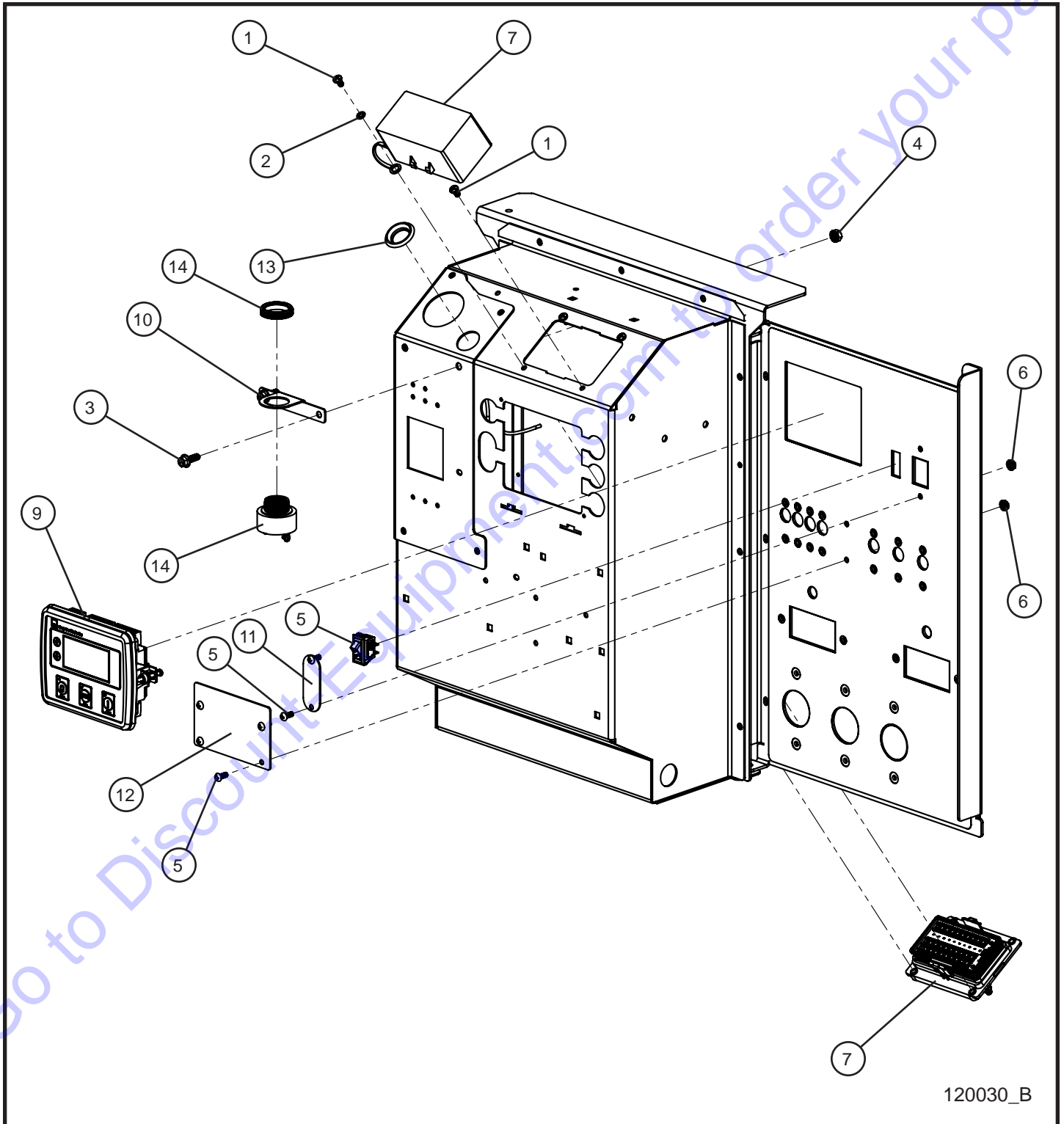

MAXI-POWER™ 15XR

SN 44-000001 and UP

3.3 - DSE 4520 MK II Control Box Assembly Group

Item	Part No.	Part Description	Qty.
1	041019	#10-32 x 3/8 PH-ROUND HEAD MACHINE SCREW	4
2	043017	#10 TOOTH LOCK WASHER	1
3	056019	1/4-20 X 3/4 HEX FLANGE SCREW GRADE 5	2
4	044021	1/4-20 KEPS HEX NUT	4
5	041021	#10-24 x 1/2 PH-ROUND HEAD MACHINE SCREW	6
6	044016	#10-24 KEPS HEX NUT	6
7	118342	HARNESS DEEP SEA CONTROL PANEL 4520 MP 15XR	1
8	113541	ROCKER SWITCH SPST ON / OFF	1
9	113504	DSE 4520 MK II CONTROL MODULE	1
10	120575P	ALARM BRACKET OLD HOLE PATTERN COMPATIBLE	1
11	117616P	COVER TOWER SWITCH	1
12	120099P	COVER LIGHT SWITCH MAXI-POWER 15XR	1
13	064025	1 1/16 PLASTIC PLUG	1
14	118086	AUDIBLE ALARM PANEL MOUNT	1
NS	103864	FUSE HOLDER INLINE BLADE	1
NS	104990	2 AMP ATO/ATC BLADE FUSE	1
NS	118347	WIRE SCHEMATIC HARNESS CONTROL MP15XR	1
NS	106037	AUTOSTART ALARM WIRE HARNESS	1

3.4 - DSE 4520 MK II PDM Fuse Box

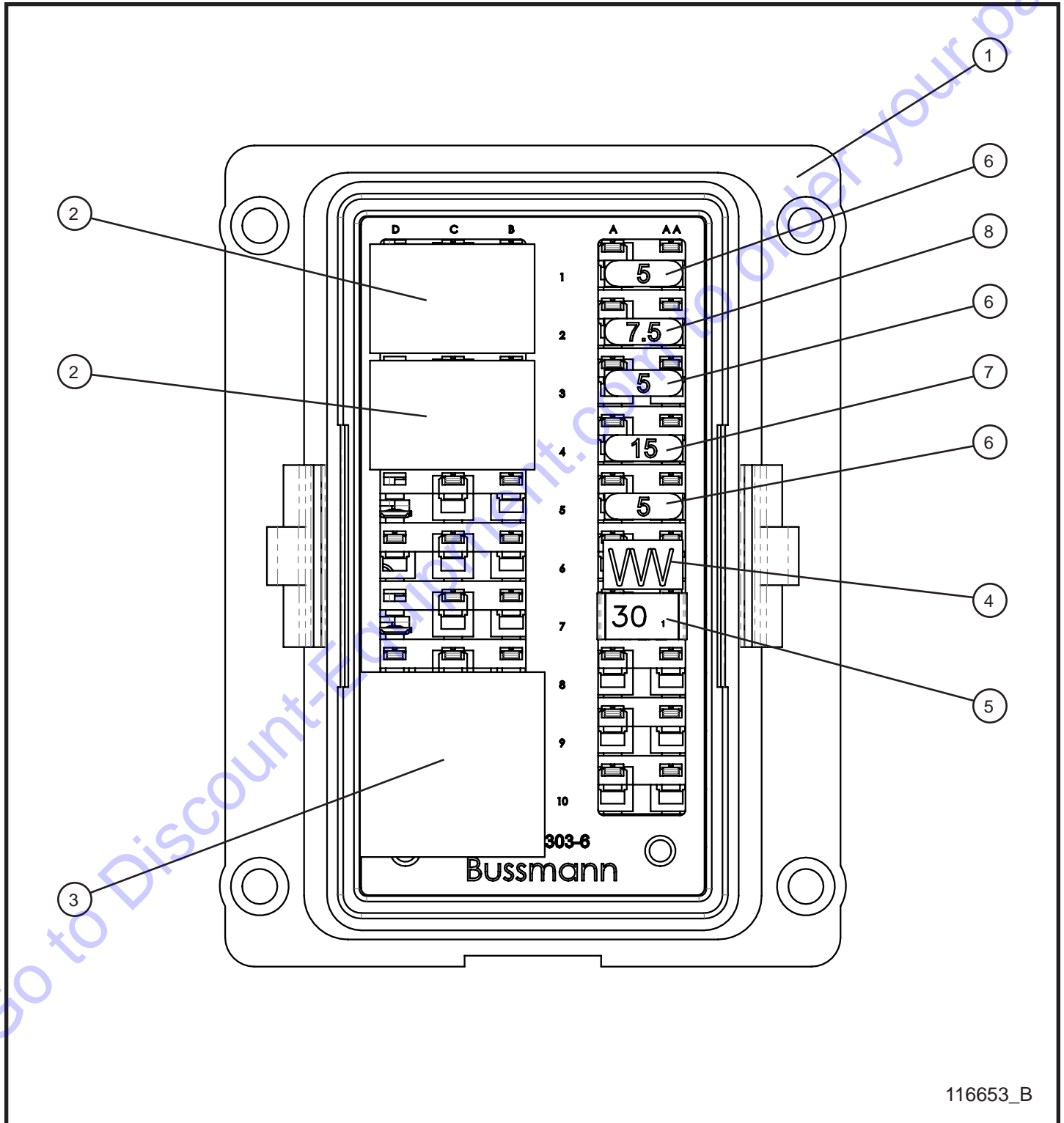

116653_B

MAXI-POWER™ 15XR

SN 44-000001 and UP

3.4 - DSE 4520 MK II PDM Fuse Box

Item	Part No.	Part Description	Qty.
--	118342	HARNESS DEEP SEA CONTROL PANEL 4520 MP 15XR	1
1	105199	BUSSMANN 45 PIN BOARD MODULE	1
2	105201	35 AMP SPST RELAY	3
3	105202	50 AMP SPST RELAY	1
4	105204	RESISTOR 68OHM	1
5	105832	CIRCUIT BREAKER 30A	1
6	105843	5A MINI FUSE	2
7	105844	15A MINI FUSE	1
8	105876	7.5A MINI FUSE	1

Go to Discount-Equipment.com to order your parts

3.5 - DSE L401 Bussman PDM Control Box Assembly Group

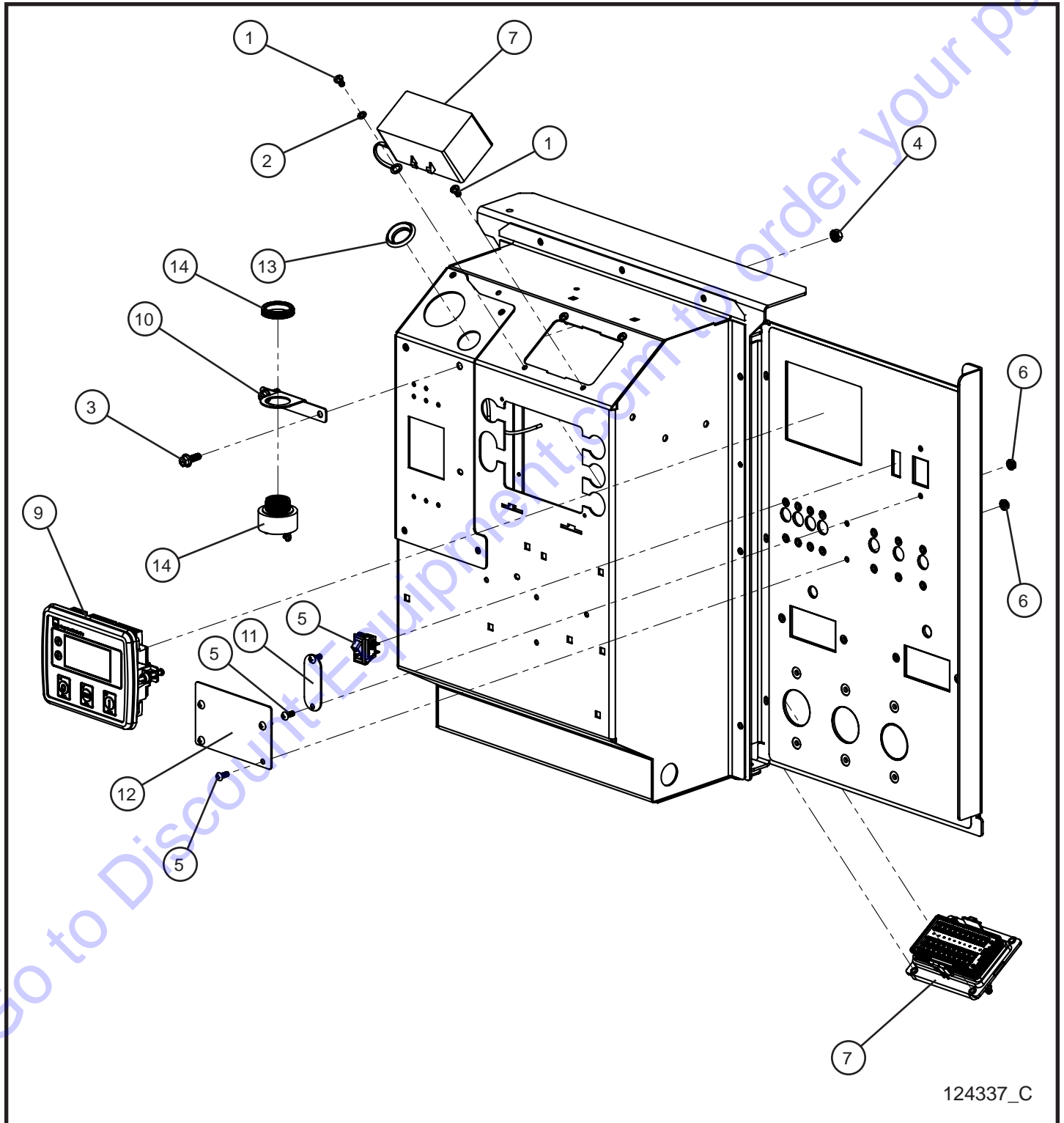

MAXI-POWER™ 15XR

SN 44-000001 and UP

3.5 - DSE L401 Bussman PDM Control Box Assembly Group

Item	Part No.	Part Description	Qty.
1	041019	#10-32 x 3/8 PH-ROUND HEAD MACHINE SCREW	4
2	043017	#10 TOOTH LOCK WASHER	1
3	056019	1/4-20 X 3/4 HEX FLANGE SCREW GRADE 5	2
4	044021	1/4-20 KEPS HEX NUT	4
5	041021	#10-24 x 1/2 PH-ROUND HEAD MACHINE SCREW	6
6	044016	#10-24 KEPS HEX NUT	6
7	123220	HARNESS DEEP SEA CONTROL PANEL L401 MP15XR	1
8	113541	ROCKER SWITCH SPST ON / OFF	1
9	110154	DSE L401 MK II CONTROL MODULE	1
10	120575P	ALARM BRACKET OLD HOLE PATTERN COMPATIBLE	1
11	117616P	COVER TOWER SWITCH	1
12	120099P	COVER LIGHT SWITCH MAXI-POWER 15XR	1
13	064025	1 1/16 PLASTIC PLUG	1
14	118086	AUDIBLE ALARM PANEL MOUNT	1
NS	103864	FUSE HOLDER INLINE BLADE	1
NS	104990	2 AMP ATO/ATC BLADE FUSE	1
NS	124336	WIRE SCHEMATIC HARNESS CONTROL MP15XR	1
NS	106037	AUTOSTART ALARM WIRE HARNESS	1

3.6 - DSE L401 Bussman PDM Fuse Box

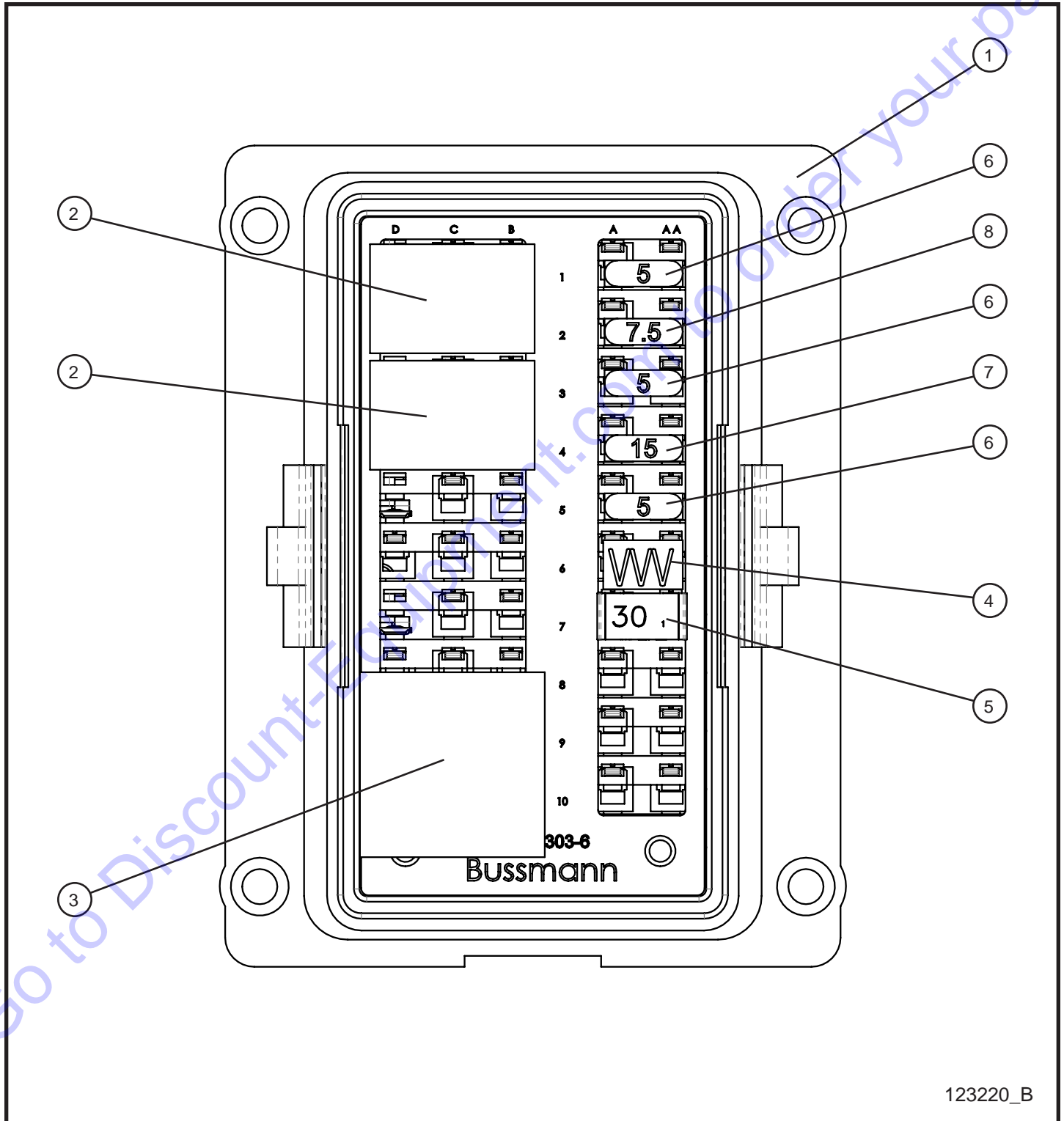

123220_B

MAXI-POWER™ 15XR

SN 44-000001 and UP

3.6 - DSE L401 Bussman PDM Fuse Box

Item	Part No.	Part Description	Qty.
--	123220	HARNESS DEEP SEA CONTROL PANEL L401 MP 15XR	1
1	105199	BUSSMANN 45 PIN BOARD MODULE	1
2	105201	35 AMP SPST RELAY	3
3	105202	50 AMP SPST RELAY	1
4	105204	RESISTOR 68OHM	1
5	105832	CIRCUIT BREAKER 30A	1
6	105843	5A MINI FUSE	2
7	105844	15A MINI FUSE	1
8	105876	7.5A MINI FUSE	1

Go to Discount-Equipment.com to order your parts

3.7 - DSE L401 Chief PDM Control Box Assembly Group

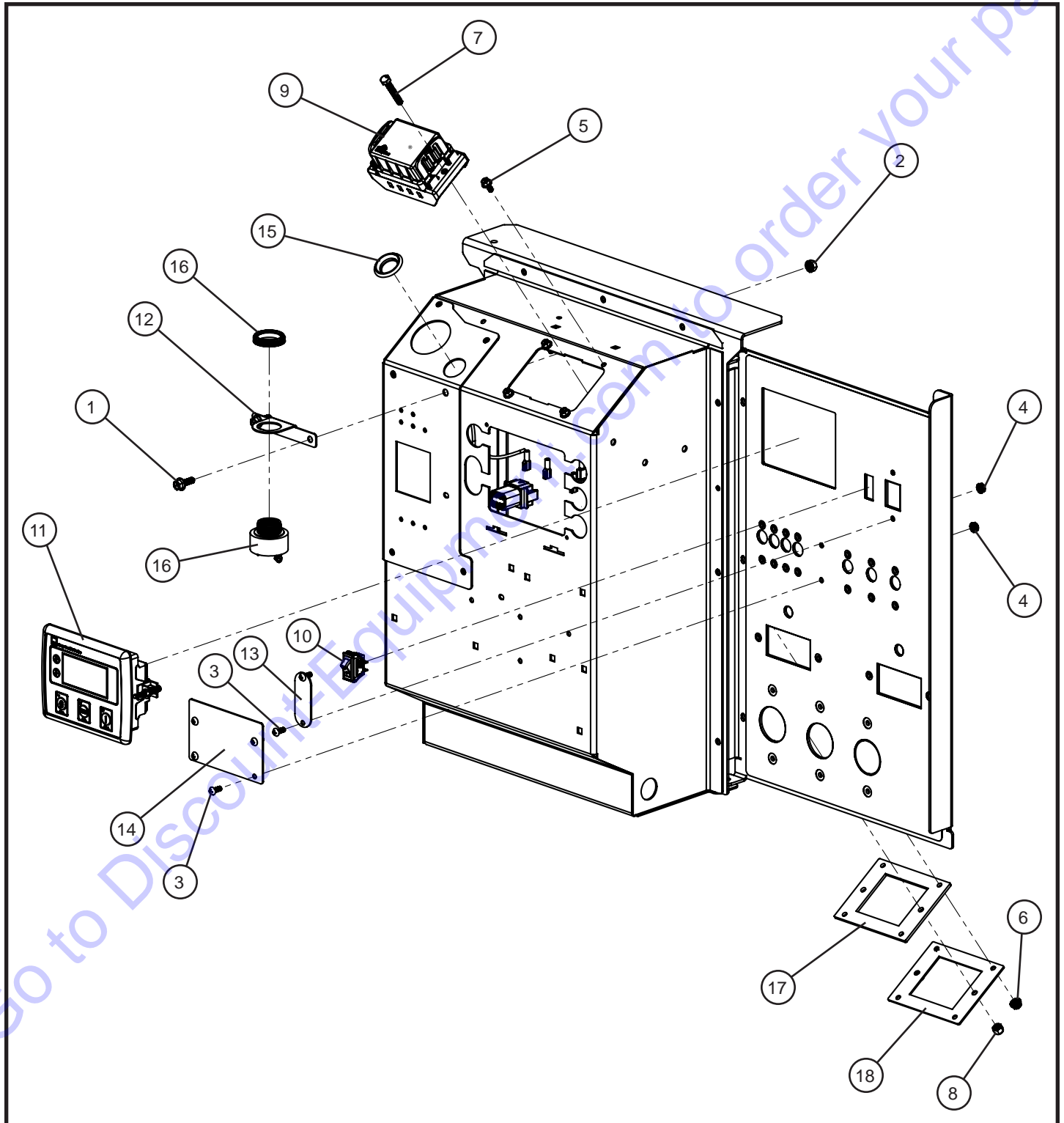

MAXI-POWER™ 15XR

SN 44-000001 and UP

3.7 - DSE L401 Chief PDM Control Box Assembly Group

Item	Part No.	Part Description	Qty.
1	056019	1/4-20 X 3/4 HEX FLANGE SCREW GRADE 5	2
2	044021	1/4-20 KEPS HEX NUT	2
3	041021	#10-24 x 1/2 PH-ROUND HEAD MACHINE SCREW	6
4	044016	#10-24 KEPS HEX NUT	6
5	056022	#10-24 X 1/2 SERRATED FLANGE HEX SCREW	4
6	057004	#10-24 SERRATED FLANGE HEX NUT	4
7	123301	M6 X 1 X40MM HEX HEAD BOLT	2
8	040013	M6 NYLOCK HEX NUT	2
9	123128	HARNESS DEEP SEA CONTROL PANEL L401 MP15XR	1
10	113541	ROCKER SWITCH SPST ON / OFF	1
11	110154	DSE L401 MK II CONTROL MODULE	1
12	120575P	ALARM BRACKET OLD HOLE PATTERN COMPATIBLE	1
13	117616P	COVER TOWER SWITCH	1
14	120099P	COVER LIGHT SWITCH MAXI-POWER 15XR	1
15	064025	1 1/16 PLASTIC PLUG	1
16	118086	AUDIBLE ALARM PANEL MOUNT	1
17	123238	FOAM GASKET PDM BOX ADAPTER PLATE	1
18	124307P	ADAPTER PLATE CHIEF PDM BOX	1
NS	123283	DECAL BILINGUAL DO NOT REMOVE	2
NS	103864	FUSE HOLDER INLINE BLADE	1
NS	104990	2 AMP ATO/ATC BLADE FUSE	1
NS	124336	WIRE SCHEMATIC HARNESS CONTROL MP15XR	1
NS	106037	AUTOSTART ALARM WIRE HARNESS	1

3.8 - DSE L401 Chief PDM Fuse Box

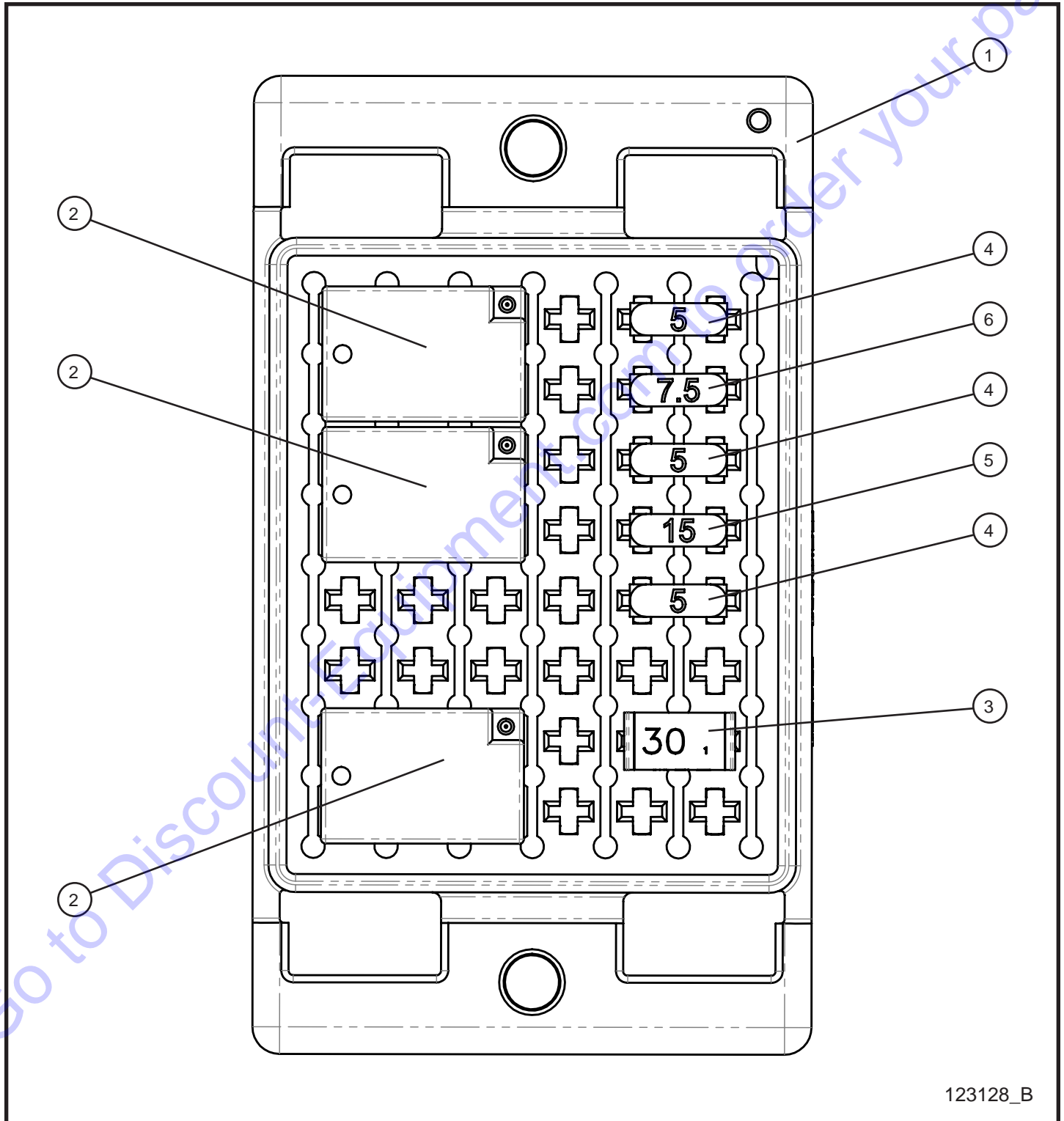

123128_B

MAXI-POWER™ 15XR

SN 44-000001 and UP

3.8 - DSE L401 Chief PDM Fuse Box

Item	Part No.	Part Description	Qty.
--	123128	HARNESS DEEP SEA CONTROL PANEL L401 MP 15XR	1
1	123116	POWER DISTRIBUTION MODULE BASE	1
2	123133	35 AMP SPST RELAY	3
3	105832	CIRCUIT BREAKER 30A	1
4	105843	5A MINI FUSE	2
5	105844	15A MINI FUSE	1
6	105876	7.5A MINI FUSE	1

Go to Discount-Equipment.com to order your parts

3.9 - 2-30A RV 2-50A RV NEMA Outlet Package

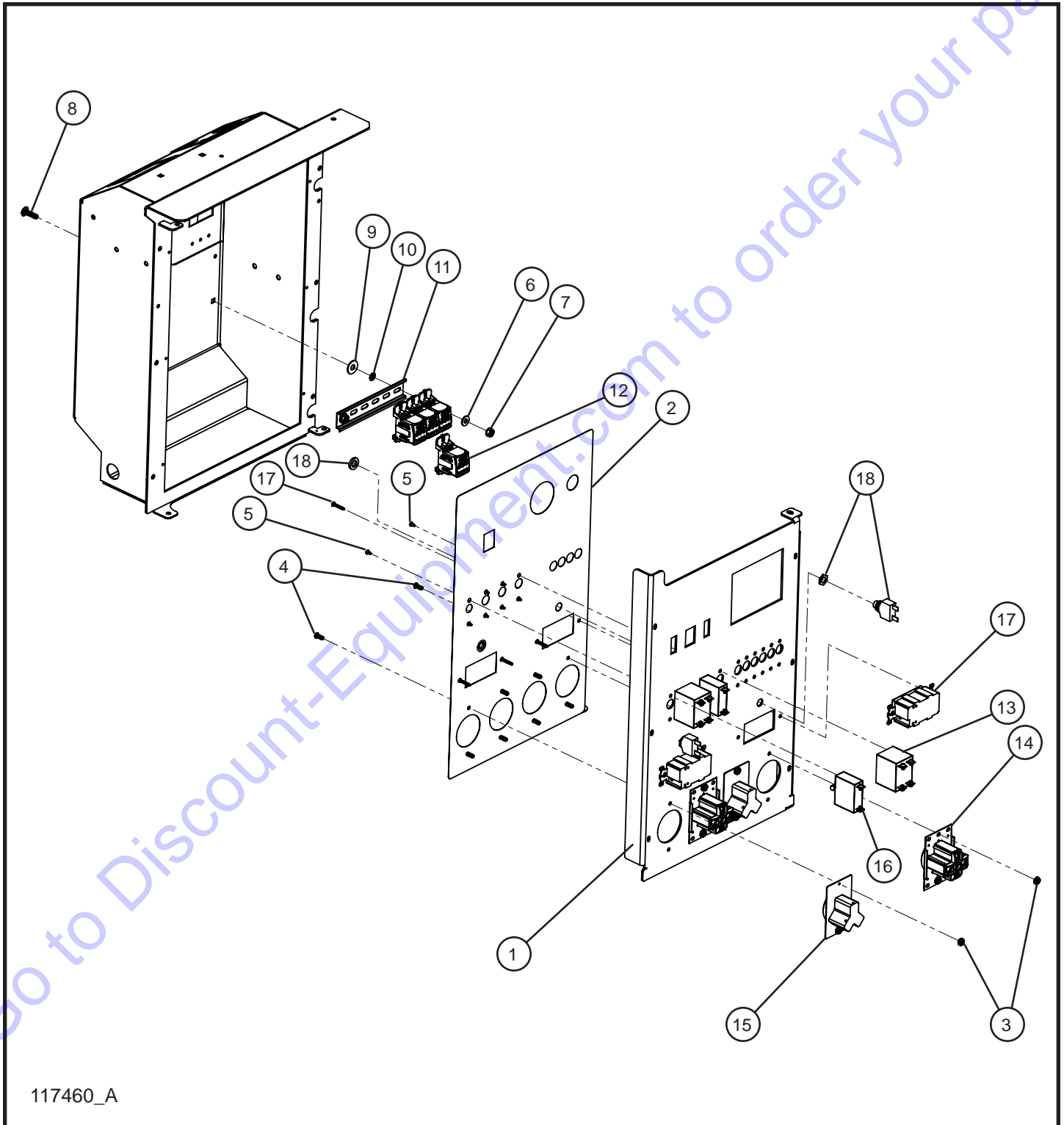

117460_A

MAXI-POWER™ 15XR

SN 44-000001 and UP

3.9 - 2-30A RV 2-50A RV NEMA Outlet Package

Item	Part No.	Part Description	Qty.
1	117546P	MAXI-LITE COMPONENT BOX DSE 4520 MK II OUTLET PANEL	1
2	116703	MAXI-LITE OUTLET PANEL DECAL	1
3	044016	#10-24 KEPS HEX NUT	8
4	041021	#10-24 x 1/2 PH-ROUND HEAD MACHINE SCREW	8
5	041018	#6-32 x 1/4 PH-ROUND HEAD MACHINE SCREW	8
6	047005	1/4 FLAT WASHER	2
7	044021	1/4-20 KEPS HEX NUT	2
8	100342	1/4-20 x 1 CARRIAGE BOLT	2
9	047010	5/16 FLAT WASHER	2
10	101701	1/4 PUSH NUT	2
11	114488	DIN RAIL 6 INCH	1
12	104779	ERIFLEX DISTRIBUTION BLOCK	4
13	353279	50A DPST CIRCUIT BREAKER	2
14	022351	50A 250V RV NEMA 14-50R RECEPTACLE	2
15	680815	30A 125V RV OUTLET	2
16	330472	30A SPST CIRCUIT BREAKER	2
17	330499	20A GFCI RECEPTACLE	2
18	650138	20A PUSH BUTTON CIRCUIT BREAKER	2
NS	117461	MAXI-LITE 2-RV 2-NEMA 2-GFCI OUTLET PANEL SCHEMATIC	1

3.10 - 2-30A Twistlock 2-50A CS6369 Twistlock Outlet Package

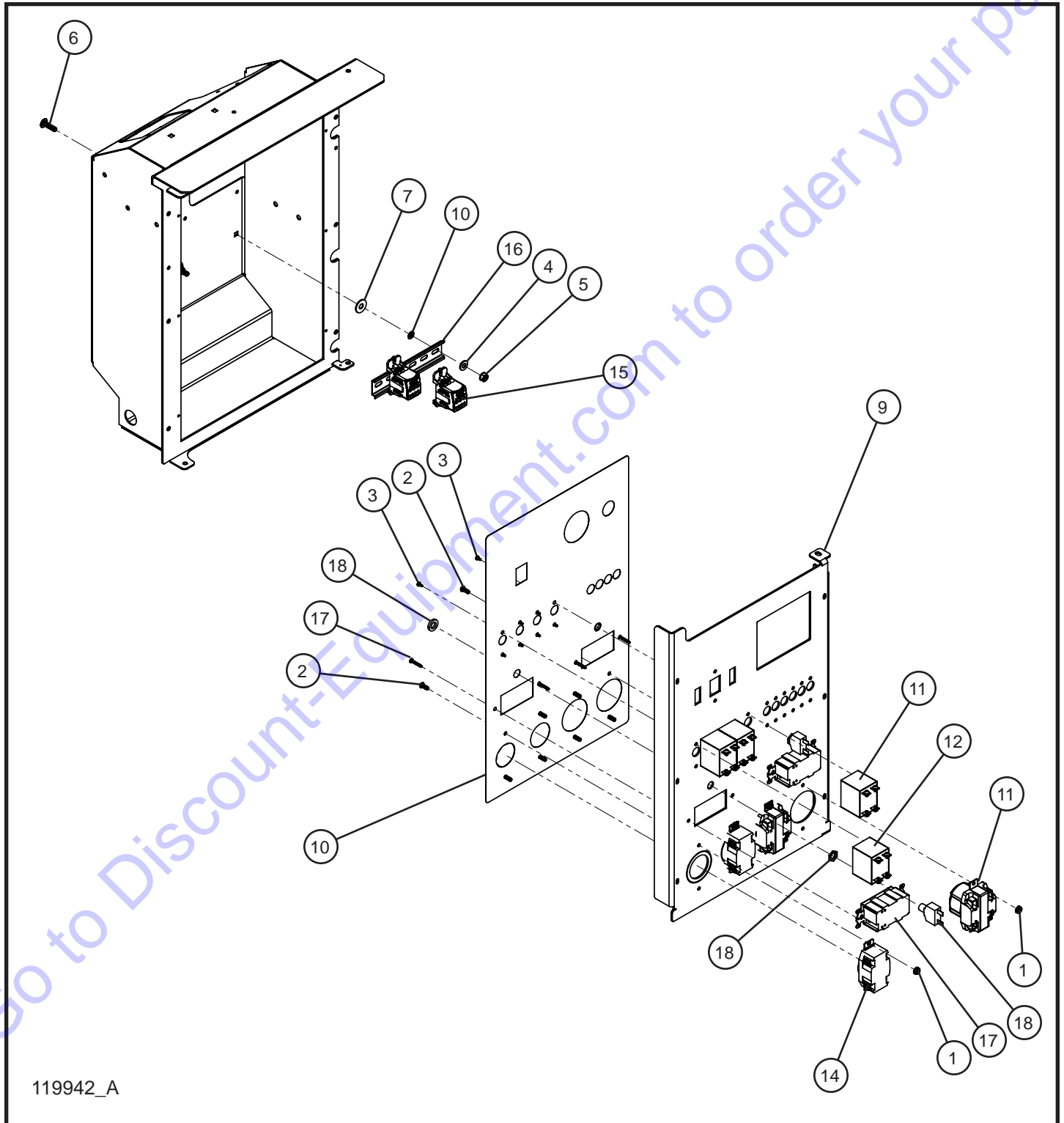

MAXI-POWER™ 15XR

SN 44-000001 and UP

3.10 - 2-30A Twistlock 2-50A CS6369 Twistlock Outlet Package

Item	Part No.	Part Description	Qty.
1	044016	#10-24 KEPS HEX NUT	8
2	041021	#10-24 x 1/2 PH-ROUND HEAD MACHINE SCREW	8
3	041018	#6-32 x 1/4 PH-ROUND HEAD MACHINE SCREW	8
4	047005	1/4 FLAT WASHER	2
5	044021	1/4-20 KEPS HEX NUT	2
6	100342	1/4-20 x 1 CARRIAGE BOLT	2
7	047010	5/16 FLAT WASHER	2
8	101701	1/4 PUSH NUT	2
9	117546P	MAXI-LITE COMPONENT BOX DSE 4520 MK II OUTLET PANEL	1
10	116703	MAXI-LITE OUTLET PANEL DECAL	1
11	104267	50A 125-250V CS6369 RECEPTACLE	2
12	353279	50A DPST CIRCUIT BREAKER	2
13	330456	30A DPST CIRCUIT BREAKER	2
14	653102	30A 125-250V TWISTLOCK RECEPTACLE	2
15	104779	ERIFLEX DISTRIBUTION BLOCK	2
16	114488	DIN RAIL 6 INCH	1
17	330499	20A GFCI RECEPTACLE	2
18	650138	20A PUSH BUTTON CIRCUIT BREAKER	2
NS	117524	50A CS6369 TO 50A RV NEMA INSTALLATION KIT	1
NS	118325	SCHEMATIC OUTLET PANEL 2-30A 2-50A TWISTLOCKS MP 15XR	1

3.11 - 2-30A Twistlock 2-50A RV NEMA Outlet Package

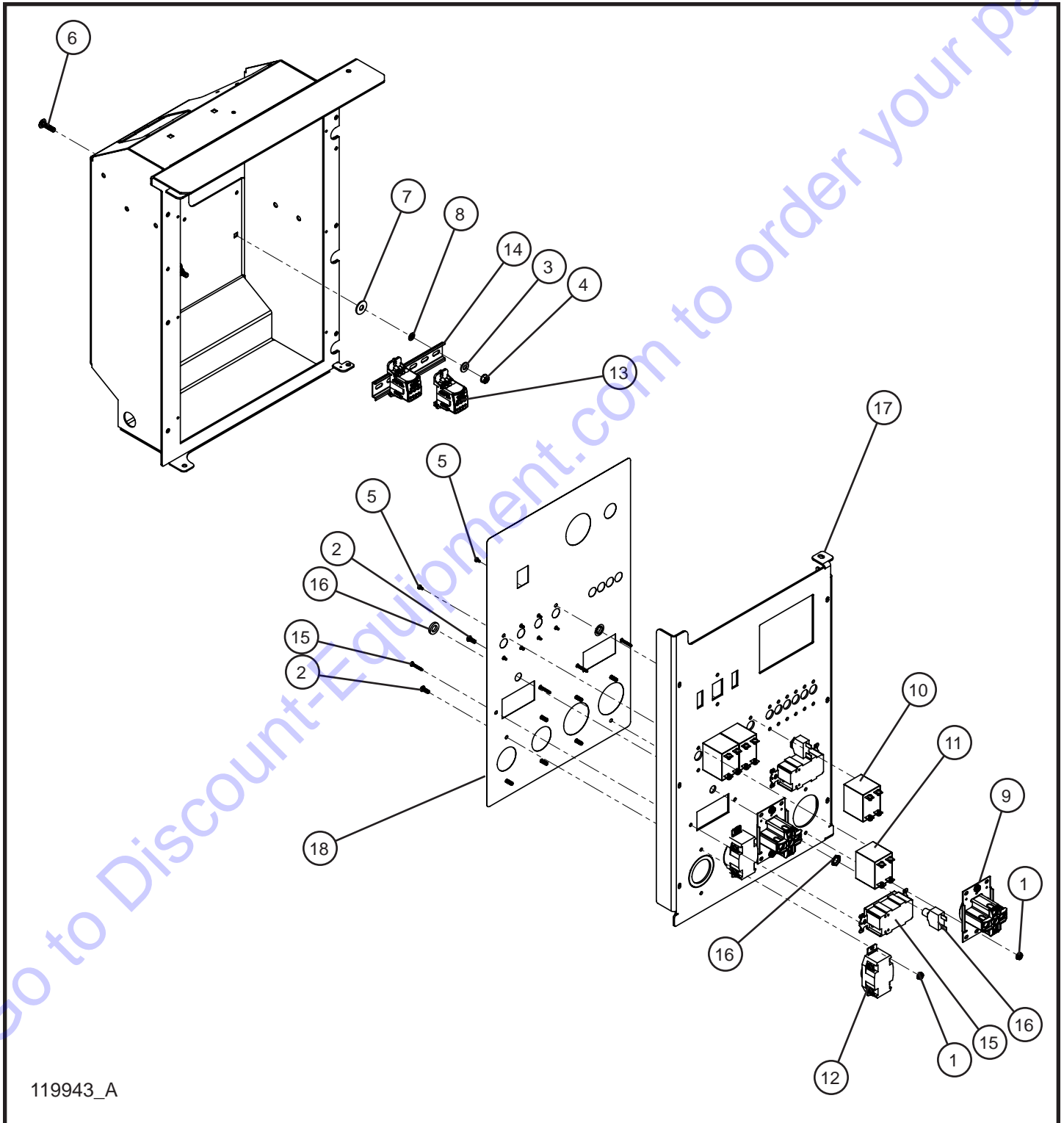

MAXI-POWER™ 15XR

SN 44-000001 and UP

3.11 - 2-30A Twistlock 2-50A RV NEMA Outlet Package

Item	Part No.	Part Description	Qty.
1	044016	#10-24 KEPS HEX NUT	8
2	041021	#10-24 x 1/2 PH-ROUND HEAD MACHINE SCREW	8
3	047005	1/4 FLAT WASHER	2
4	044021	1/4-20 KEPS HEX NUT	2
5	041018	#6-32 x 1/4 PH-ROUND HEAD MACHINE SCREW	8
6	100342	1/4-20 x 1 CARRIAGE BOLT	2
7	047010	5/16 FLAT WASHER	2
8	101701	1/4 PUSH NUT	2
9	022351	50A 250V RV NEMA 14-50R RECEPTACLE	2
10	353279	50A DPST CIRCUIT BREAKER	2
11	330456	30A DPST CIRCUIT BREAKER	2
12	653102	30A 125-250V TWISTLOCK RECEPTACLE	2
13	104779	ERIFLEX DISTRIBUTION BLOCK	2
14	114488	DIN RAIL 6 INCH	1
15	330499	20A GFCI RECEPTACLE	2
16	650138	20A PUSH BUTTON CIRCUIT BREAKER	2
17	117546P	MAXI-LITE COMPONENT BOX DSE 4520 MK II OUTLET PANEL	1
18	116703	MAXI-LITE OUTLET PANEL DECAL	1
NS	118326	SCHEMATIC OUTLET PANEL 2-50A RV MP 15XR	1

4.1 - Battery Cables

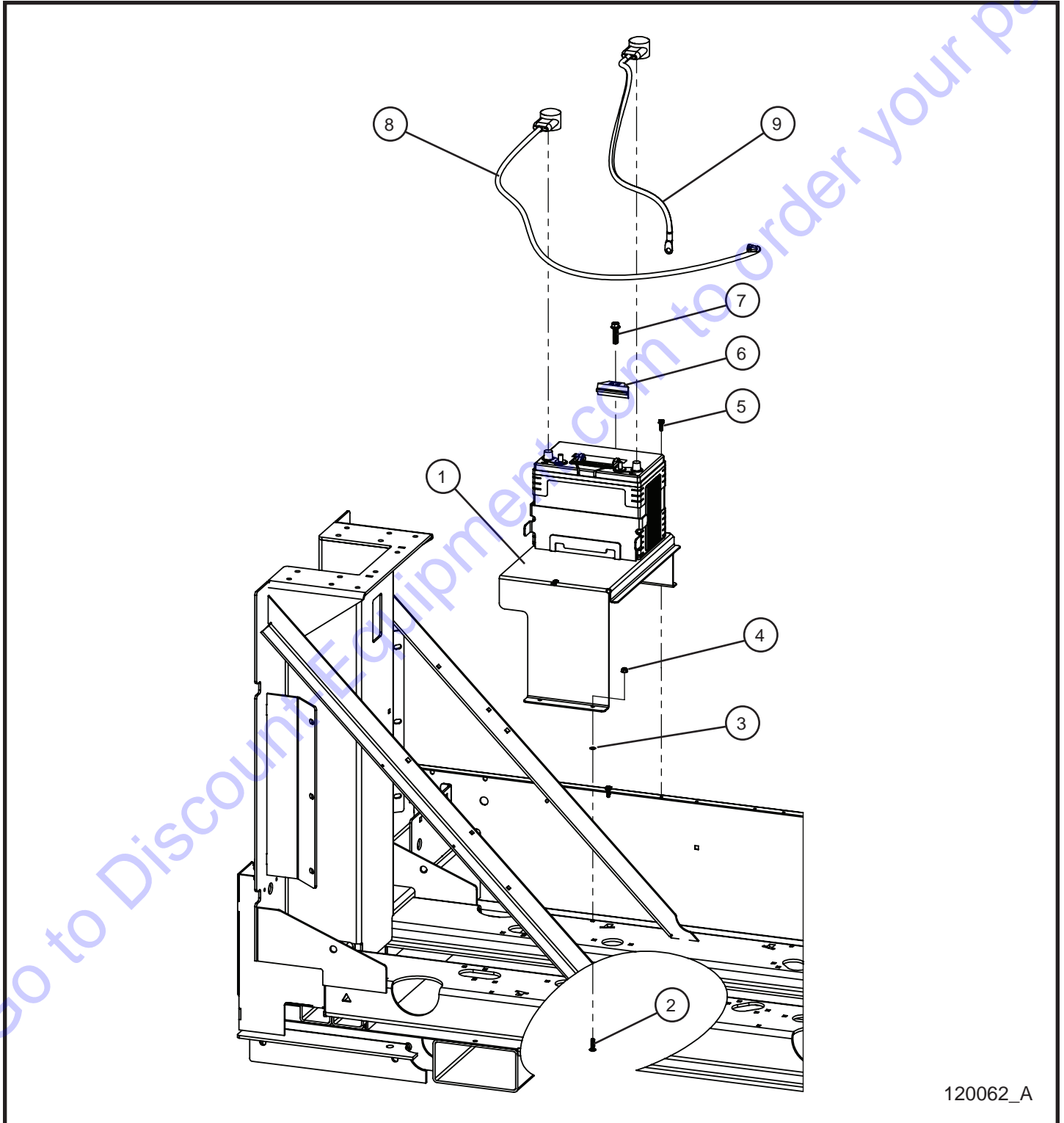

120062_A

MAXI-POWER™ 15XR

SN 44-000001 and UP

4.1 - Battery Cables

Item	Part No.	Part Description	Qty.
1	120059P	MAXI-LITE DUAL BATTERY MOUNT	1
2	100342	1/4-20 x 1 CARRIAGE BOLT	2
3	101701	1/4 PUSH NUT	2
4	057001	1/4-20 HEX NYLOCK FLANGE NUT	2
5	041070	1/4-20 x 3/4 SL-HEX WASHER HEAD MACHINE SCREW	2
6	107115	BATTERY HOLD DOWN	1
7	056015	3/8-16 x 1 1/2 HEX FLANGE SCREW	1
8	113656	2GA x 42.00 RED BATTERY CABLE	1
9	027015	2GA x 27.00 BLACK BATTERY CABLE	1

Go to Discount-Equipment.com to order your parts

4.2 - Battery Disconnect Cables

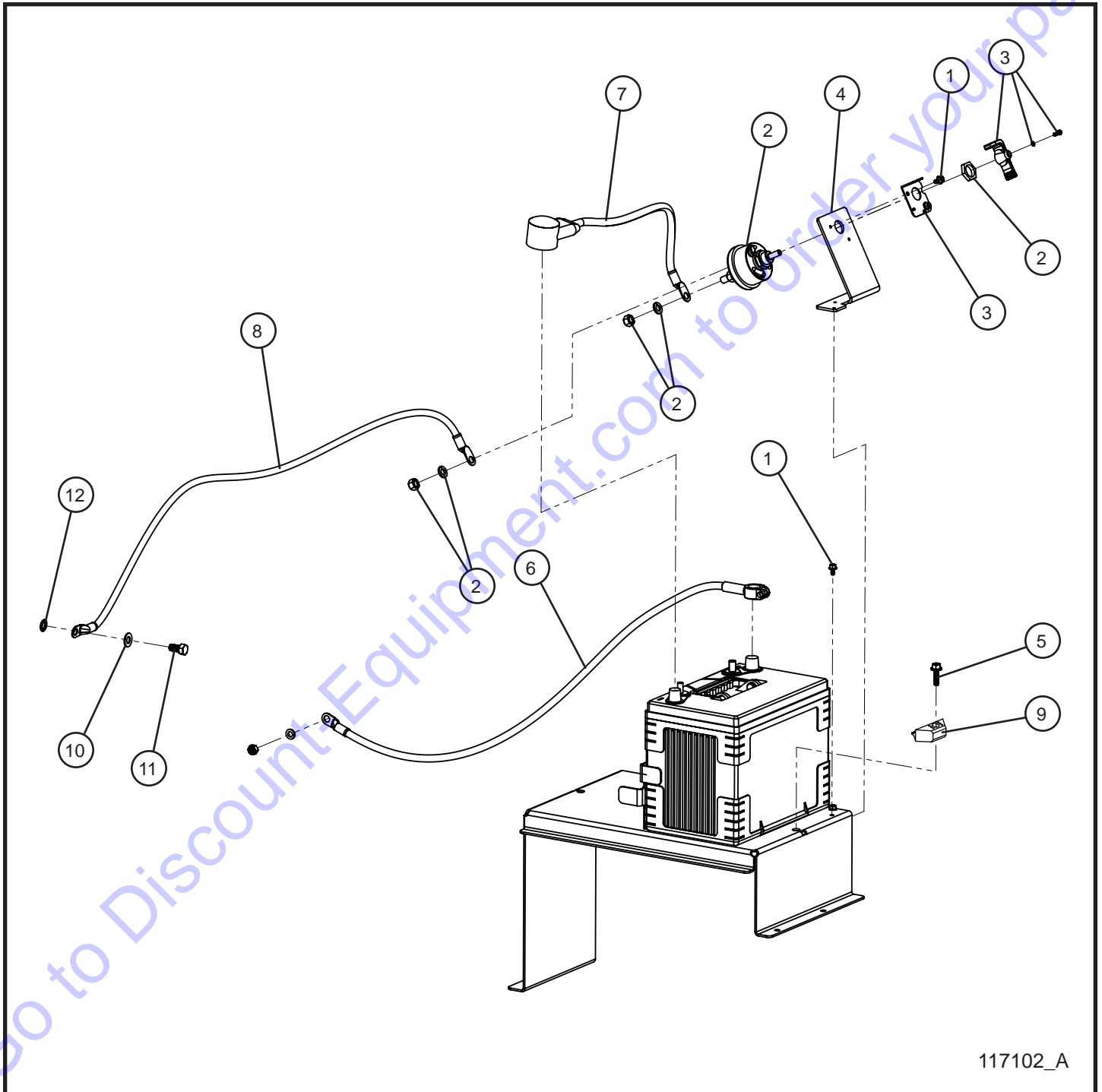

117102_A

MAXI-POWER™ 15XR

SN 44-000001 and UP

4.2 - Battery Disconnect Cables

Item	Part No.	Part Description	Qty.
1	056016	#10-24 x 3/8 SERRATED FLANGE HEX BOLT	4
2	102534	4 TERMINAL BATTERY DISCONNECT SWITCH	1
3	103483	LOCK OUT BATTERY DISCONNECT	1
4	114659P	MAXI-LITE BATTERY DISCONNECT MOUNT	1
5	056015	3/8-16 x 1 1/2 HEX FLANGE SCREW	1
6	113656	2GA x 42.00 RED BATTERY CABLE	1
7	110373	2GA x 16.00 BLACK BATTERY CABLE	1
8	105111	2GA x 42.00 BLACK BATTERY CABLE	1
9	107115	BATTERY HOLD DOWN	1
10	047016	3/8 FLAT WASHER	1
11	046105	3/8-16 x 3/4 HEX HEAD BOLT	1
12	043070	3/8 INTL TOOTH LOCK WASHER	1
NS	105301	BATTERY DISCONNECT SCHEMATIC	1

Go to Discount-Equipment.com to order your parts

4.3 - Battery Charger and Battery Blanket Options

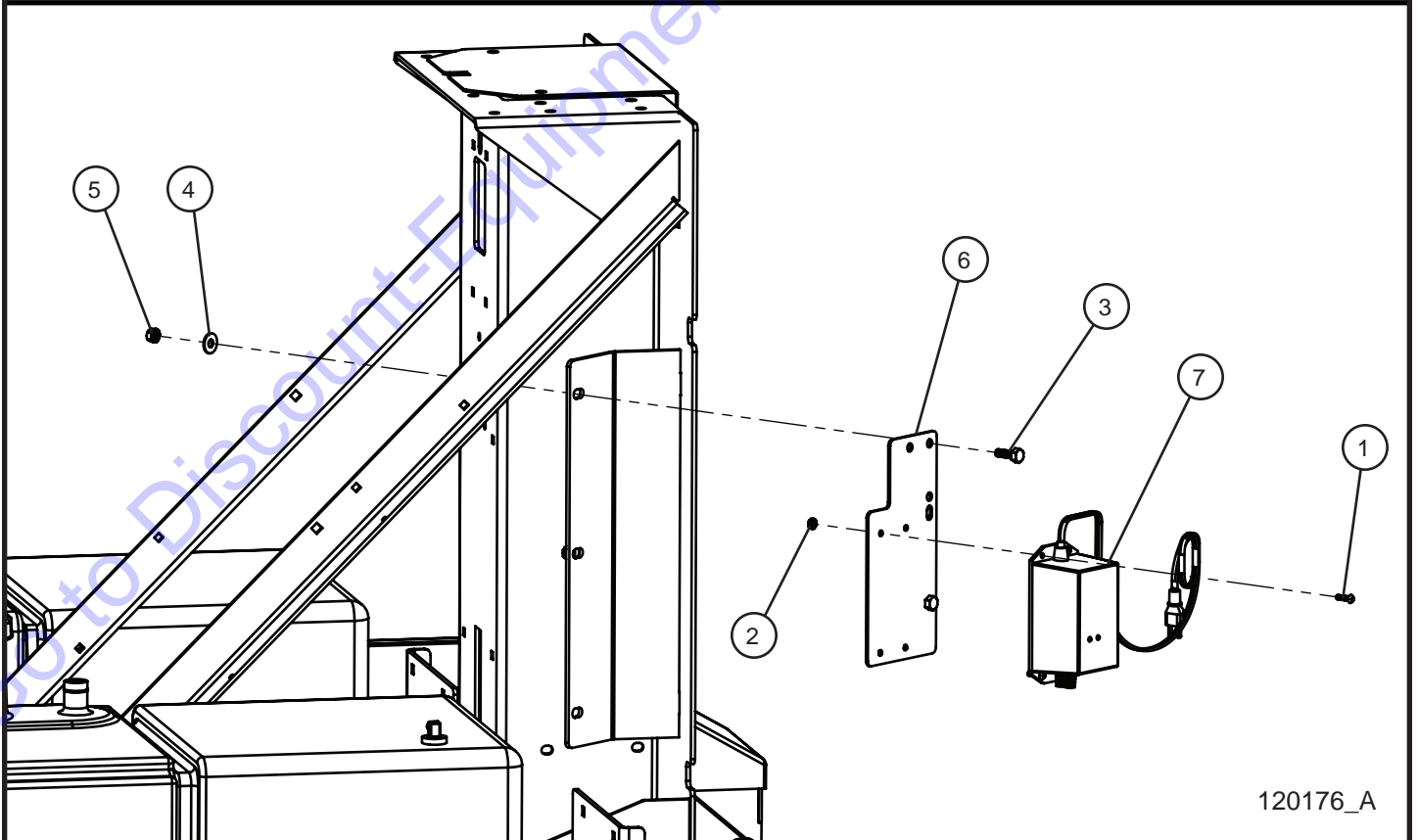
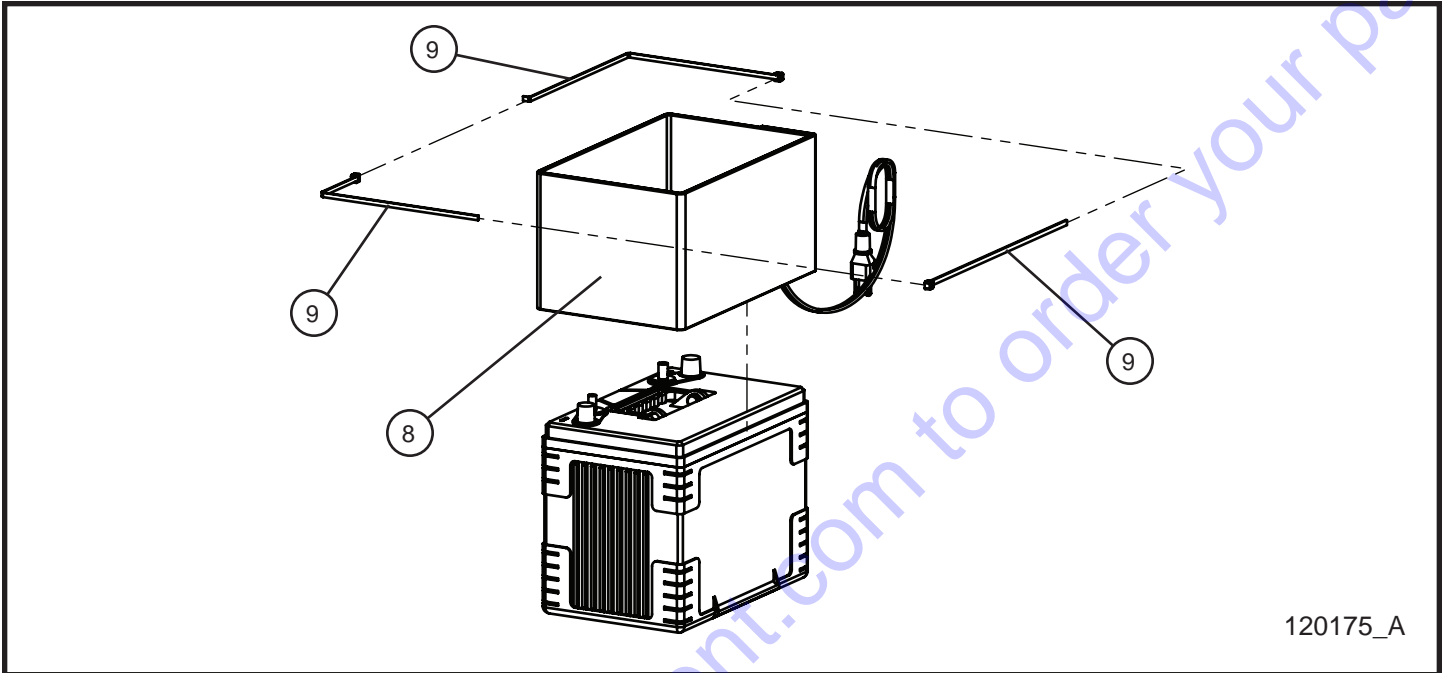

MAXI-POWER™ 15XR

SN 44-000001 and UP

4.3 - Battery Charger and Battery Blanket Options

Item	Part No.	Part Description	Qty.
1	041027	#10-24 x 3/4 PH-ROUND HEAD	4
2	044016	#10-24 KEPS HEX NUT	4
3	046050	5/16-18 x 1 HEX HEAD	2
4	047010	5/16 FLAT WASHER	2
5	044031	5/16-18 KEPS HEX NUT	2
6	114785P	MOUNT BATTERY CHARGER MAXI-AIR	1
7	120198	BATTERY CHARGER MAXI-POWER 15XR	1
8	024010	80 WATT BATTERY BLANKET	1
9	068046	15 INCH BLACK CABLE TIE	3
NS	105843	5A MINI FUSE	1
NS	120199	SCHEMATIC SINGLE BATTERY CHARGER MAXI-POWER 15XR	1

Go to Discount-Equipment.com to order your parts

PARTS FINDER

**Search Website
by Part Number**



**Search Manual
Library For Parts
Manual & Lookup Part
Numbers – Purchase
or Request Quote**

**Can't Find Part or
Manual? Request Help
by Manufacturer,
Model & Description**

Discount-Equipment.com is your online resource for quality parts & equipment.

Florida: **561-964-4949** Outside Florida TOLL FREE: **877-690-3101**

Need parts?

Click on this link: <http://www.discount-equipment.com/category/5443-parts/> and choose one of the options to help get the right parts and equipment you are looking for. Please have the machine model and serial number available in order to help us get you the correct parts. If you don't find the part on the website or on one of the online manuals, please fill out the request form and one of our experienced staff members will get back to you with a quote for the right part that your machine needs.

We sell worldwide for the brands: Genie, Terex, JLG, MultiQuip, Mikasa, Essick, Whiteman, Mayco, Toro Stone, Diamond Products, Generac Magnum, Airman, Haulotte, Barreto, Power Blanket, Nifty Lift, Atlas Copco, Chicago Pneumatic, Allmand, Miller Curber, Skyjack, Lull, Skytrak, Tsurumi, Husquvarna Target, Stow, Wacker, Sakai, Mi-T-M, Sullair, Basic, Dynapac, MBW, Weber, Bartell, Bennar Newman, Haulotte, Ditch Runner, Menegotti, Morrison, Contec, Buddy, Crown, Edco, Wyco, Bomag, Laymor, EZ Trench, Bil-Jax, F.S. Curtis, Gehl Pavers, Heli, Honda, ICS/PowerGrit, IHI, Partner, Imer, Clipper, MMD, Koshin, Rice, CH&E, General Equipment, Amida, Coleman, NAC, Gradall, Square Shooter, Kent, Stanley, Tamco, Toku, Hatz, Kohler, Robin, Wisconsin, Northrock, Oztec, Toker TK, Rol-Air, APT, Wylie, Ingersoll Rand / Doosan, Innovatech, Con X, Ammann, Mecalac, Makinex, Smith Surface Prep, Small Line, Wanco, Yanmar

4.4 - Side Marker Lights and Tail Lights

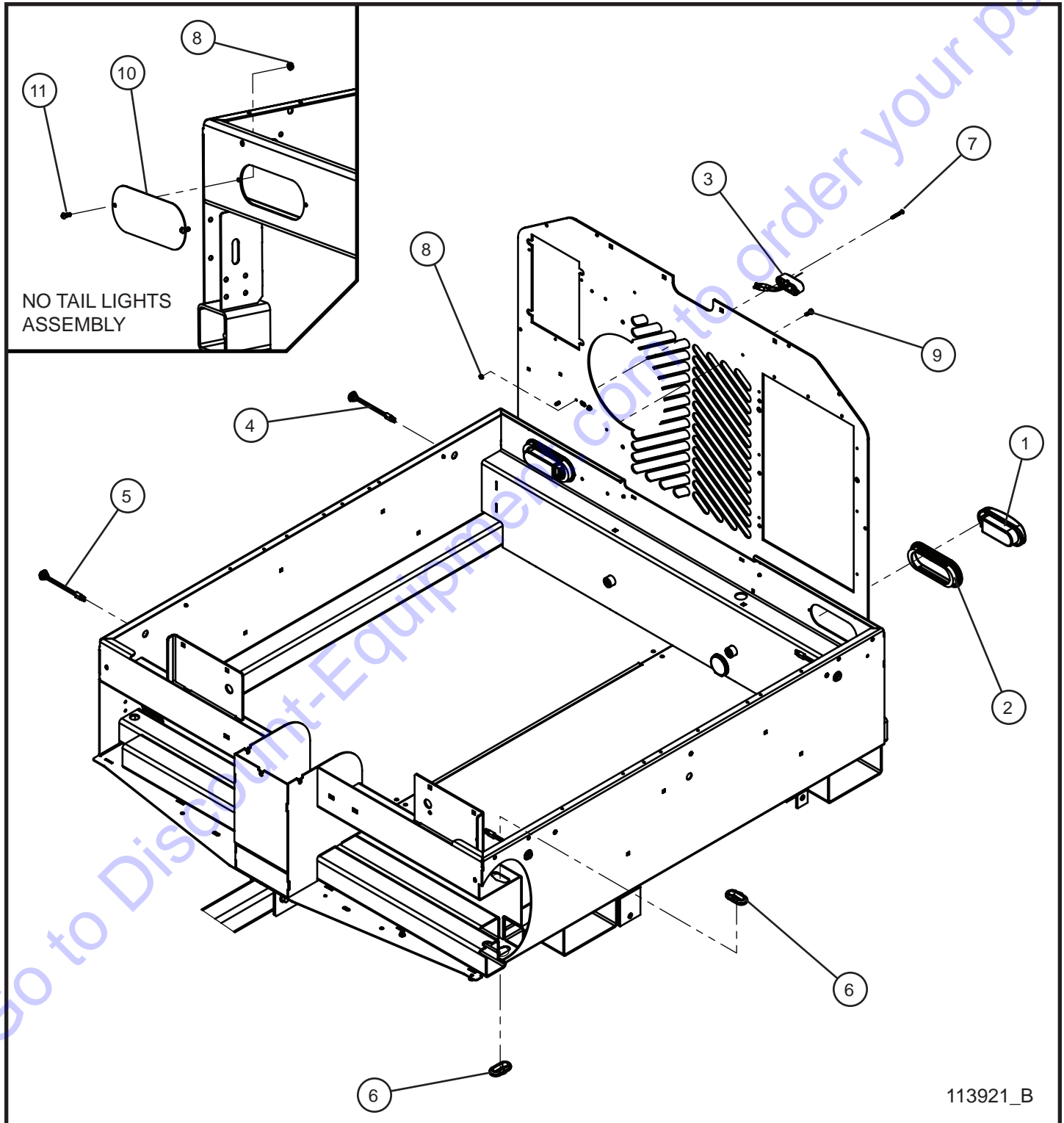

MAXI-POWER™ 15XR

SN 44-000001 and UP

4.4 - Side Marker Lights and Tail Lights

Item	Part No.	Part Description	Qty.
1	102721	LED TAIL LAMP	2
2	102825	GROMMET	2
3	115116	LICENSE PLATE LED LIGHT	1
4	106211	RED BULLET LED MARKER LIGHT	2
5	106212	AMBER BULLET LED MARKER LIGHT	2
6	106542	RUBBER GROMMET	2
7	041040	#10-24 x 1 1/2 PH-ROUND HEAD MACHINE SCREW	2
8	044016	#10-24 KEPS HEX NUT	6
9	041070	1/4-20 x 3/4 SL-HEX WASHER HEAD MACHINE SCREW	2
10	105414P	COVER PLATE OVAL TAILLIGHT HOLE	2
11	041021	#10-24 x 1/2 PH-ROUND MS PL	4
NS	113663	MAXI-LITE TAIL LIGHT BASE HARNESS	1
NS	113861	BREAK AWAY KIT TAIL LIGHT HARNESS	1
NS	114032	MAXI-LITE ELECTRIC BRAKE TAIL LIGHT HARNESS SCHEMATIC	1

Go to Discount-Equipment.com to order your parts

4.5 - Breakaway Kit

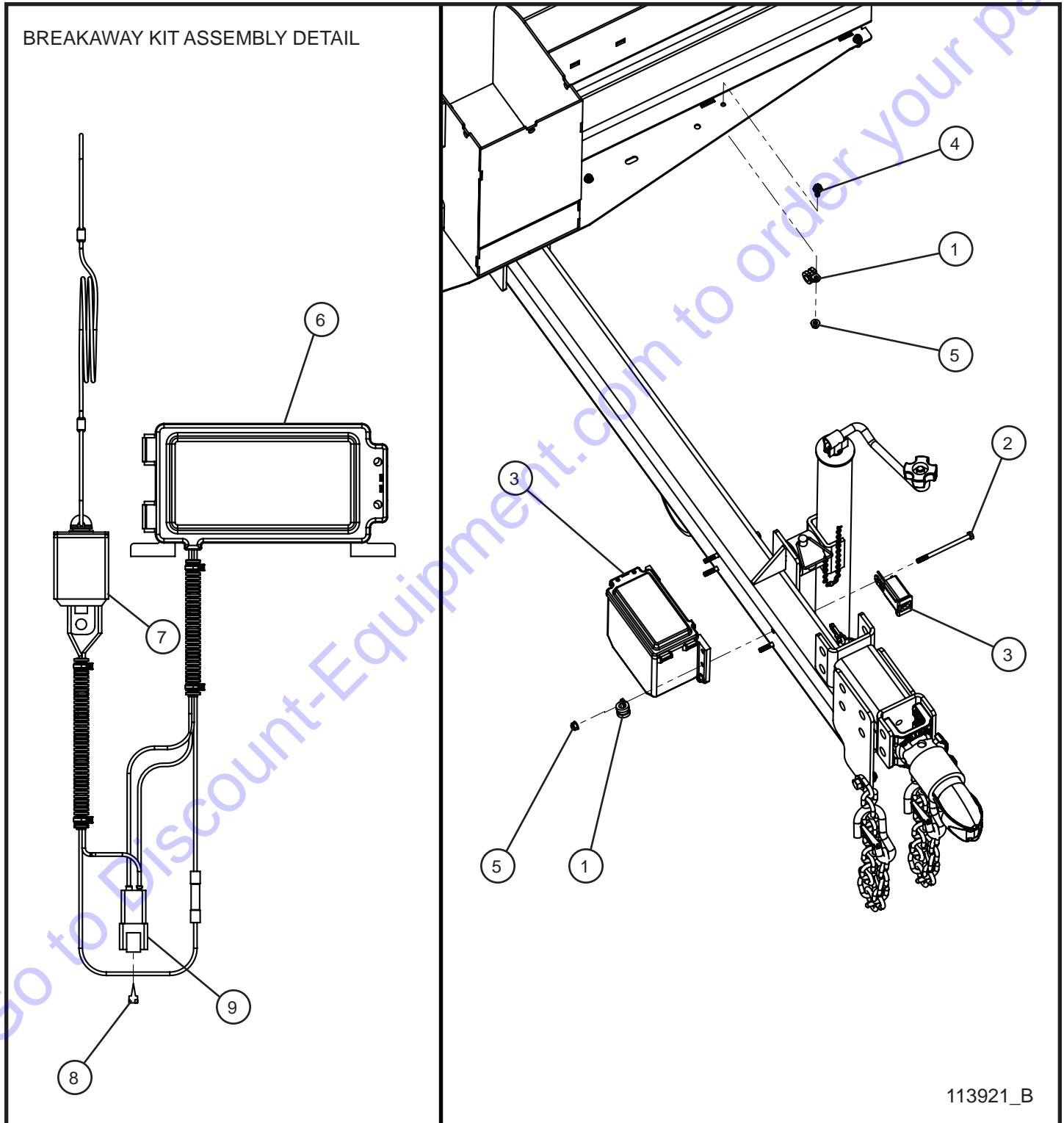

MAXI-POWER™ 15XR

SN 44-000001 and UP

4.5 - Breakaway Kit

Item	Part No.	Part Description	Qty.
1	310212	#10 CUSH CLAMP 1/4 HOLE	4
2	046039	1/4-20 x 4 HEX HEAD BOLT	4
3	113855	MAXI-LITE BREAK AWAY KIT ASSEMBLY	1
4	056002	1/4-20 x 3/4 HEX SERRATED FLANGE SCREW	3
5	057001	1/4-20 HEX NYLOCK FLANGE NUT	7
6	106578	BREAKAWAY KIT	1
7	113065	BREAKAWAY SWITCH AND LANYARD ASSEMBLY	1
8	105847	4-WAY RECEPTACLE WEDGELOCK	1
9	105207	4-WAY RECEPTACLE	1
NS	113663	MAXI-LITE TAIL LIGHT BASE HARNESS	1
NS	113861	BREAK AWAY KIT TAIL LIGHT HARNESS	1
NS	114032	MAXI-LITE ELECTRIC BRAKE TAIL LIGHT HARNESS SCHEMATIC	1

4.6 - Emergency Stop

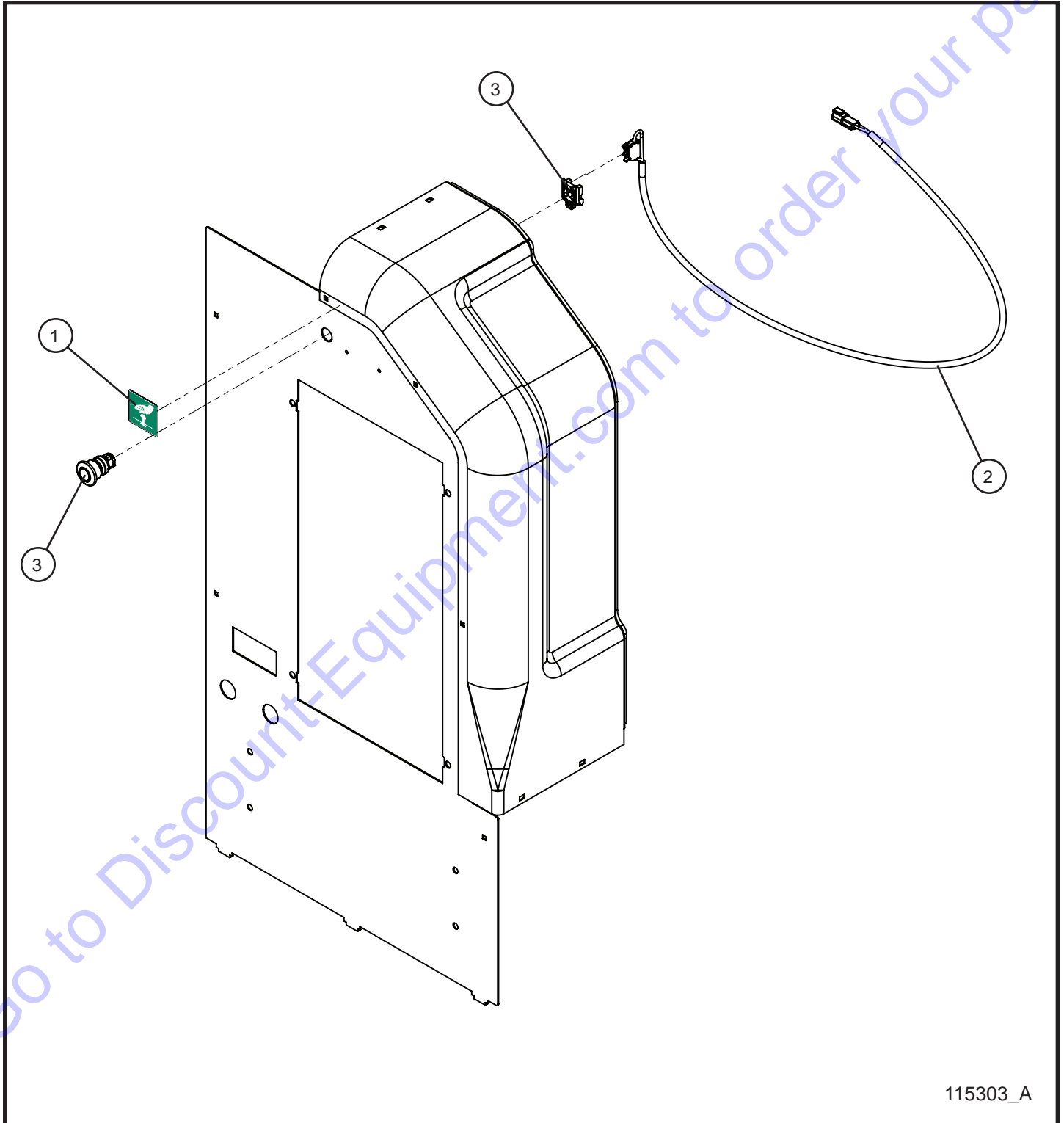

115303_A

MAXI-POWER™ 15XR

SN 44-000001 and UP

4.6 - Emergency Stop

Item	Part No.	Part Description	Qty.
1	105567	EMERGENCY STOP DECAL	1
2	105991	MAXI-LITE EMERGENCY STOP WIRE HARNESS	1
3	108912	40mm PUSH-PULL EMERGENCY STOP 22mm MOUNTING	1

Go to Discount-Equipment.com to order your parts

5.1 - Engine Isolator Mounts

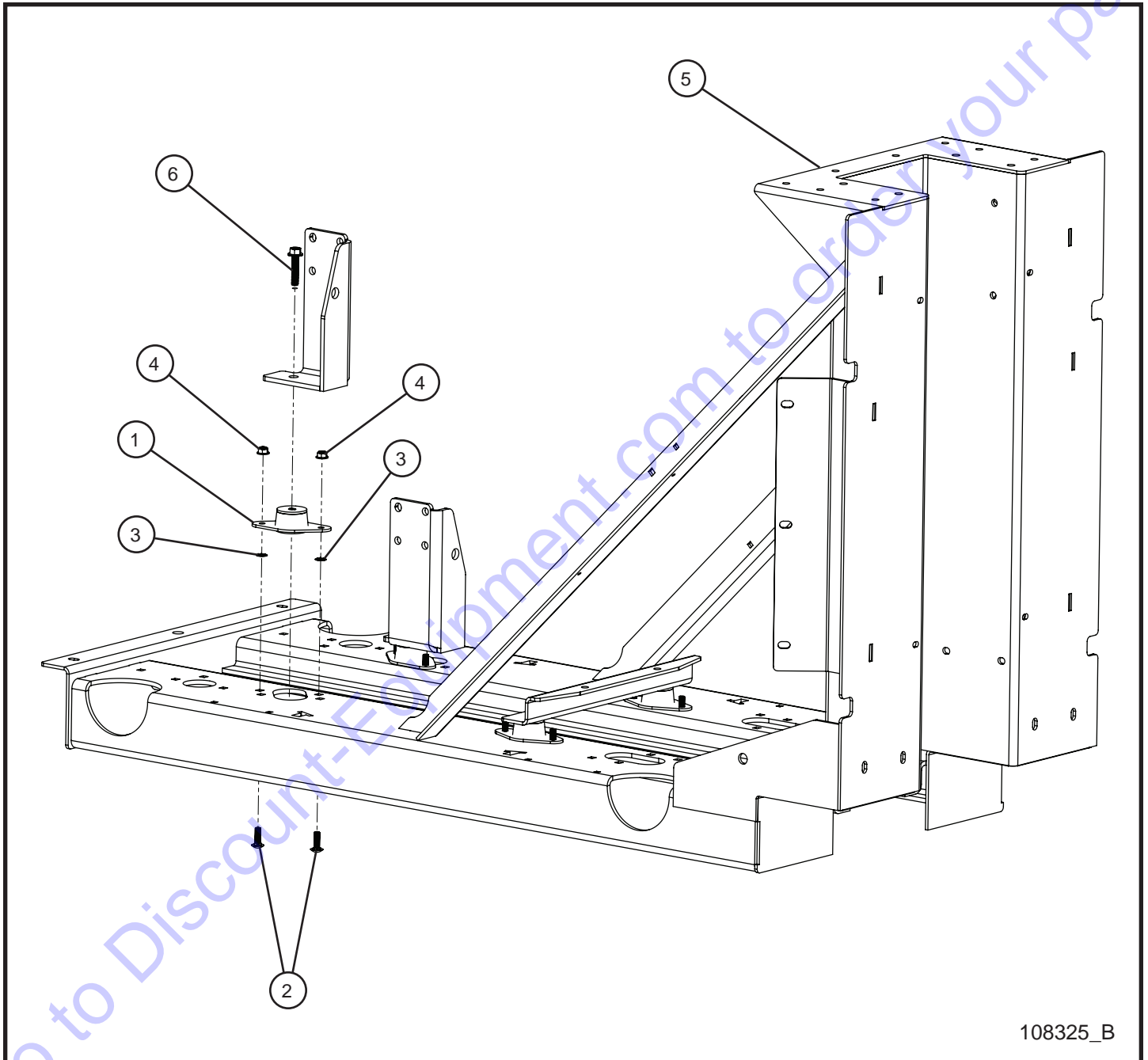

MAXI-POWER™ 15XR

SN 44-000001 and UP

5.1 - Engine Isolator Mounts

Item	Part No.	Part Description	Qty.
1	107029	HEAVY DUTY ENGINE ISOLATOR MOUNT	4
2	053020	5/16-18 x 1 CARRIAGE BOLT	8
3	045217	5/16 PUSH NUT	8
4	057008	5/16-18 HEX NYLOCK FLANGE NUT	8
5	113631P	ENGINE CRADLE REINFORCED MAXI-LITE II	1
6	056013	3/8-16 x 1 3/4 SERRATED FLANGE BOLT WITH THREAD LOCK	4

Go to Discount-Equipment.com to order your parts

5.2 - Fluid Containment Drain Cap

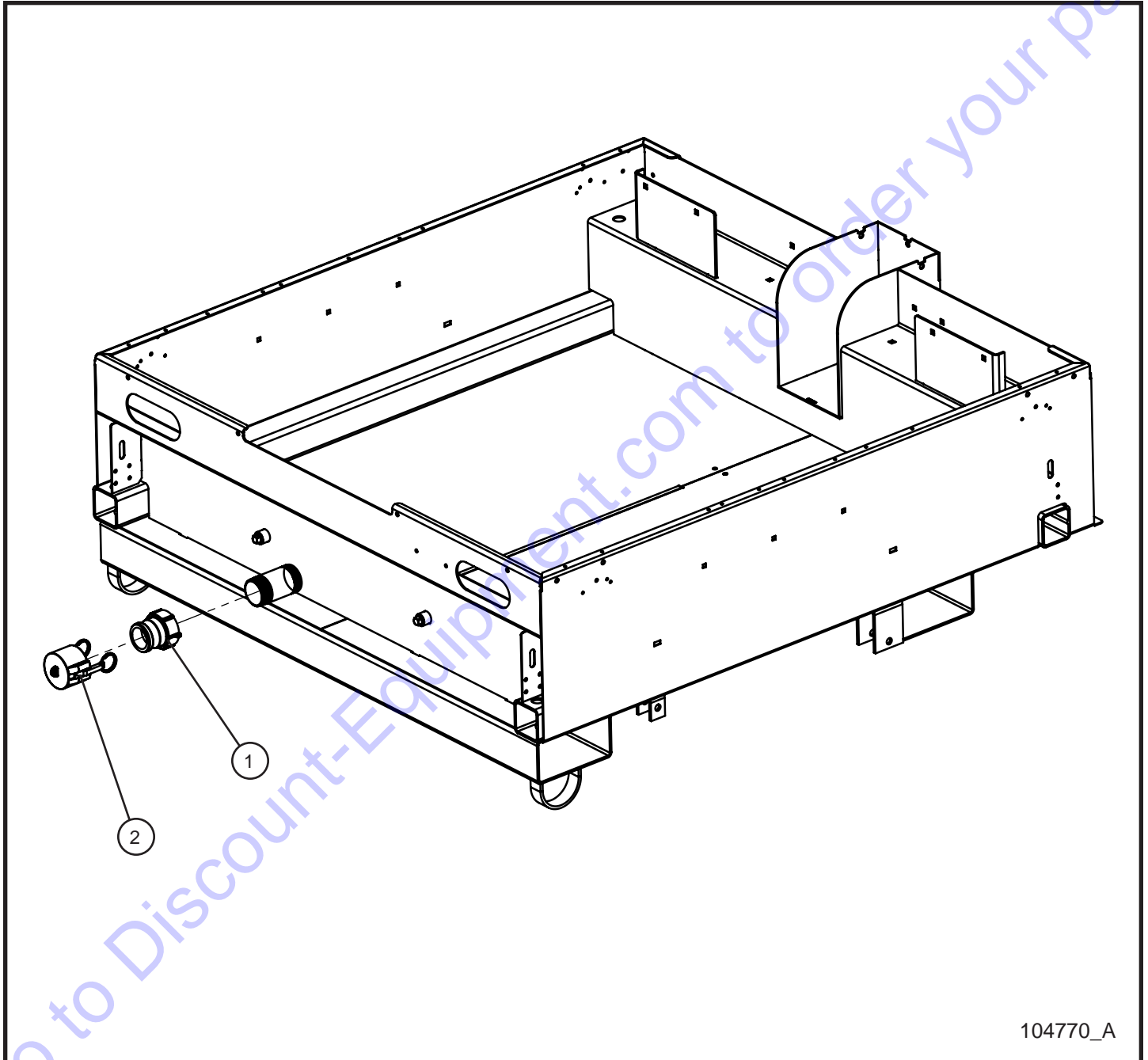

MAXI-POWER™ 15XR

SN 44-000001 and UP

5.2 - Fluid Containment Drain Cap

Item	Part No.	Part Description	Qty.
1	104464	PIPE CONNECTION 2 INCH COUPLING	1
2	104463	CAP 2 INCH COUPLING	1

Go to Discount-Equipment.com to order your parts

5.3 - Fuel Tanks

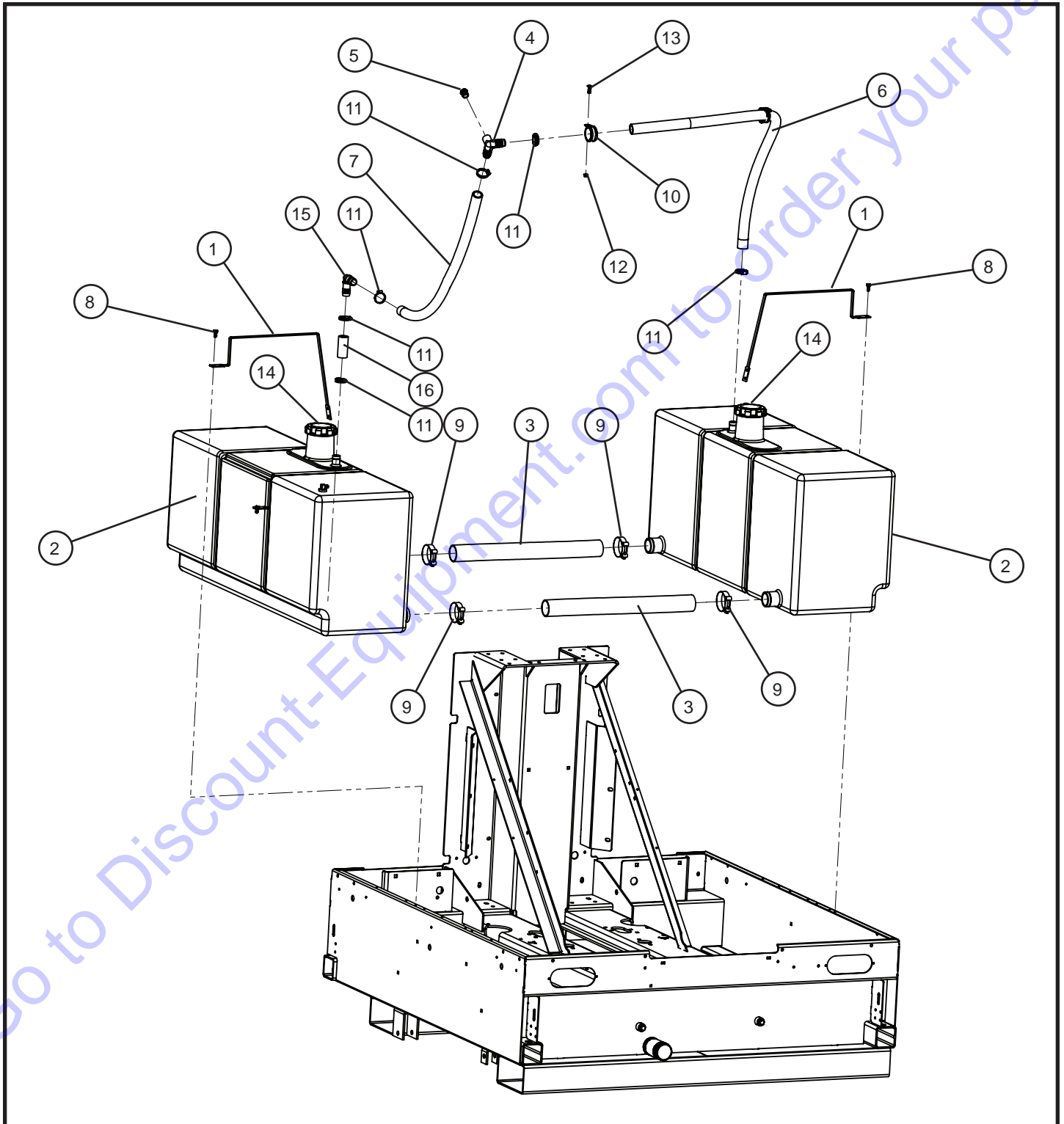

MAXI-POWER™ 15XR

SN 44-000001 and UP

5.3 - Fuel Tanks

Item	Part No.	Part Description	Qty.
1	104698P	STRAP TIEDOWN FUEL TANK	3
2	107062	FUEL TANK 51.5 GALLON FAST FILL	2
3	104383	CROSSOVER HOSE FUEL TANKS	2
4	106131	PVC Y FITTING 1 x 1 x 1/2 NPT	1
5	106132	FITTING BREATHER 1/2 NPT	1
6	106129	VENT HOSE x 53.00	1
7	106129	VENT HOSE x 26.00	1
8	041070	1/4-20 x 3/4 SL-HEX WASHER HEAD MACHINE SCREW	3
9	114176	2.13 STAINLESS STEEL T-BOLT CLAMP	4
10	106144	1 1/2 CUSH CLAMP W/ 3/8 HOLE	2
11	045034	#16 HOSE CLAMP	6
12	100342	1/4-20 x 1 CARRIAGE BOLT	2
13	057001	1/4-20 HEX NYLOCK FLANGE NUT	2
14	104532	FUEL CAP NON-VENTED	2
15	123282	1 X 1 90 DEGREE PVC HOSE BARB ELBOW	1
16	106129	VENT HOSE X 3.00	1
NS	106153	FUEL SUCTION TUBE ASSEMBLY	2
	340025C	DAPCO GROMMET	2
NS	047010	5/16 FLAT WASHER	3
NS	101701	1/4 PUSH NUT	2

5.4 - Fuel Level Sender

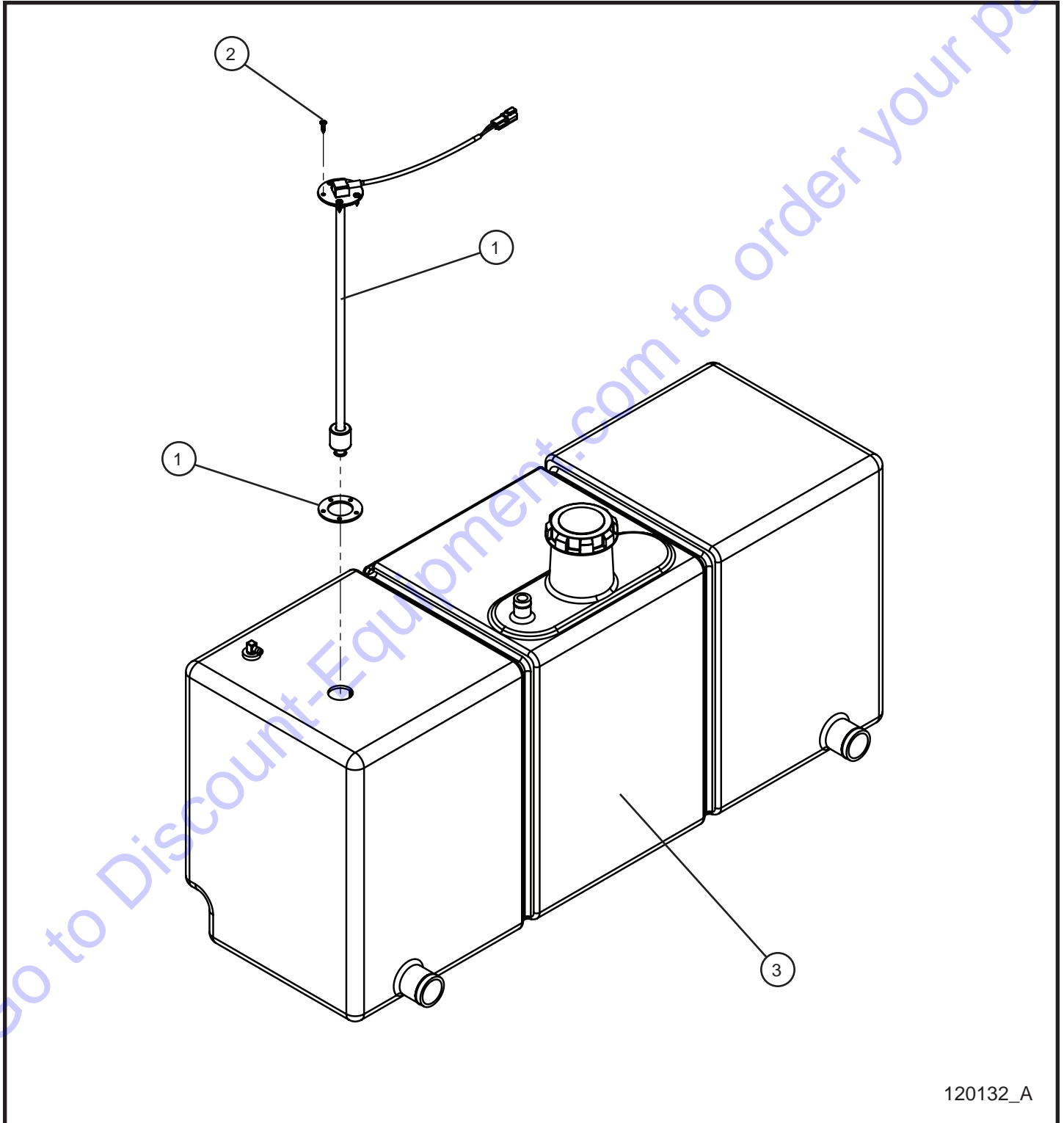

120132_A

MAXI-POWER™ 15XR

SN 44-000001 and UP

5.4 - Fuel Level Sender

Item	Part No.	Part Description	Qty.
1	110088	VERTICAL SHAFT FUEL LEVEL SENDER	1
2	102556	SCREW #8 x 3/4	5
3	107062	FUEL TANK 51.5 GALLON FAST FILL	2
NS	110090	HARNESS SENDER FUEL LEVEL	1
NS	110089	WIRE SCHEMATIC LOW FUEL SENDER	1

Go to Discount-Equipment.com to order your parts

5.5 - Heated Fuel/Water Separator

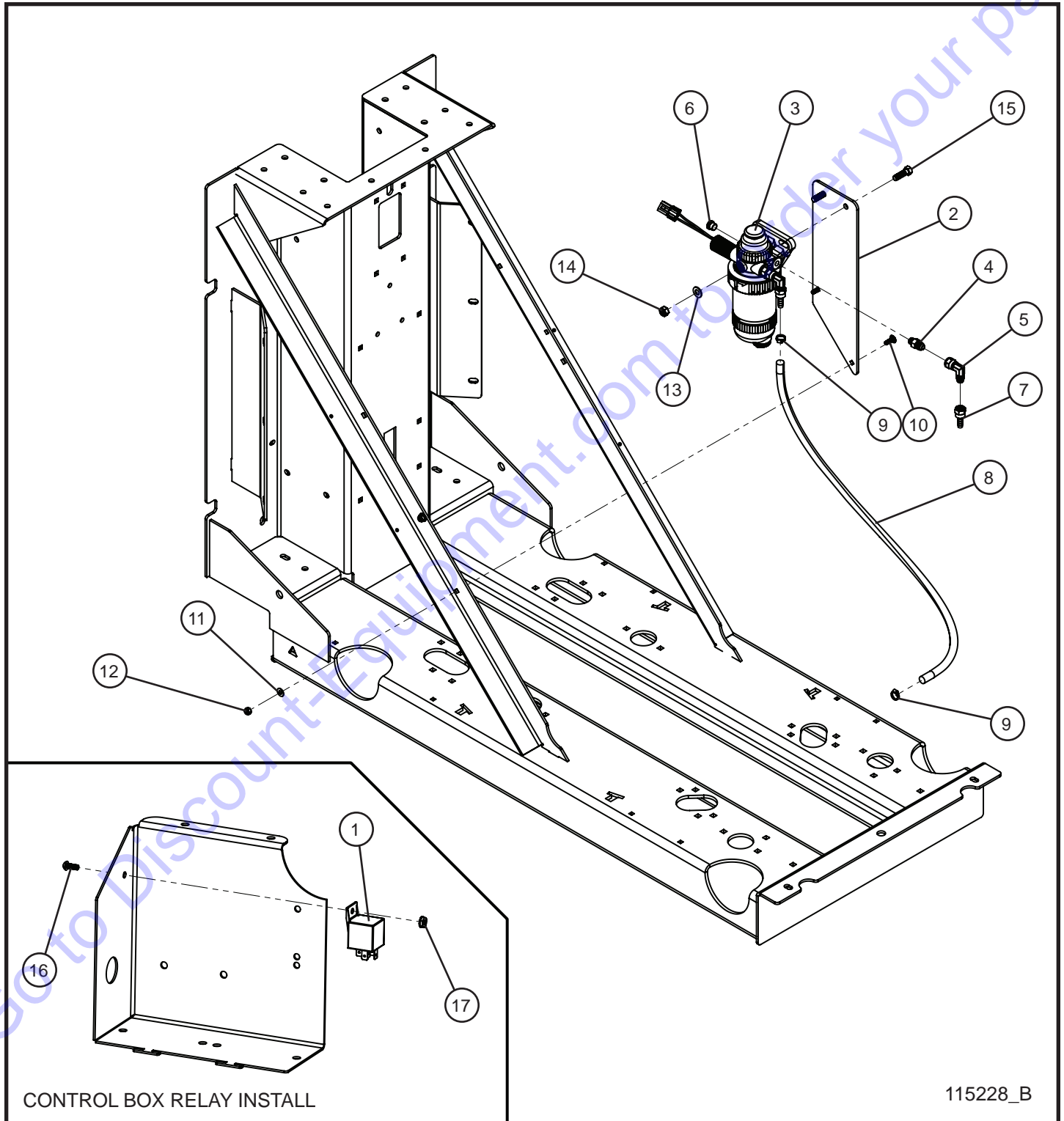

MAXI-POWER™ 15XR

SN 44-000001 and UP

5.5 - Heated Fuel/Water Separator

Item	Part No.	Part Description	Qty.
1	104254	RELAY 12V 40AMP	1
2	104630P	PLATE MOUNT WATER SEPARATOR	1
3	118676	HEATER PREFILTER ASSY STANADYNE	1
4	100655	1/2-20 x -6 JIC STRAIGHT CONNECTOR	2
5	101263	-6 JIC 90° SWIVEL FITTING	2
6	101267	1/2-20 HOLLOW HEX PLUG	1
7	106030	-6 JIC 5/16 FITTING HOSE BARB	2
8	081018	HOSE 5/16 x 40.0	1
9	433400	#4 HOSE CLAMP	2
10	053102	1/4-20 x 3/4 CARRIAGE BOLT	2
11	047009	1/4 FLAT WASHER	2
12	044023	1/4-20 NYLOCK HEX NUT	2
13	047016	3/8 FLAT WASHER	2
14	044038	3/8-16 NYLOCK HEX NUT	2
15	046115	3/8-16 x 1 1/4 HEX HEAD BOLT	2
16	041021	#10-24 x 1/2 PH-ROUND HEAD MACHINE SCREW	1
17	044016	#10-24 KEPS HEX NUT	1
NS	118686	REPLACEMENT FILTER ELEMENT	1
NS	100613	STANDADYNE HEATER ELEMENT	1
NS	105886	HEATED FUEL WATER SEPARATOR SCHEMATIC	1

5.6 - Radiator Coolant Recovery Tank

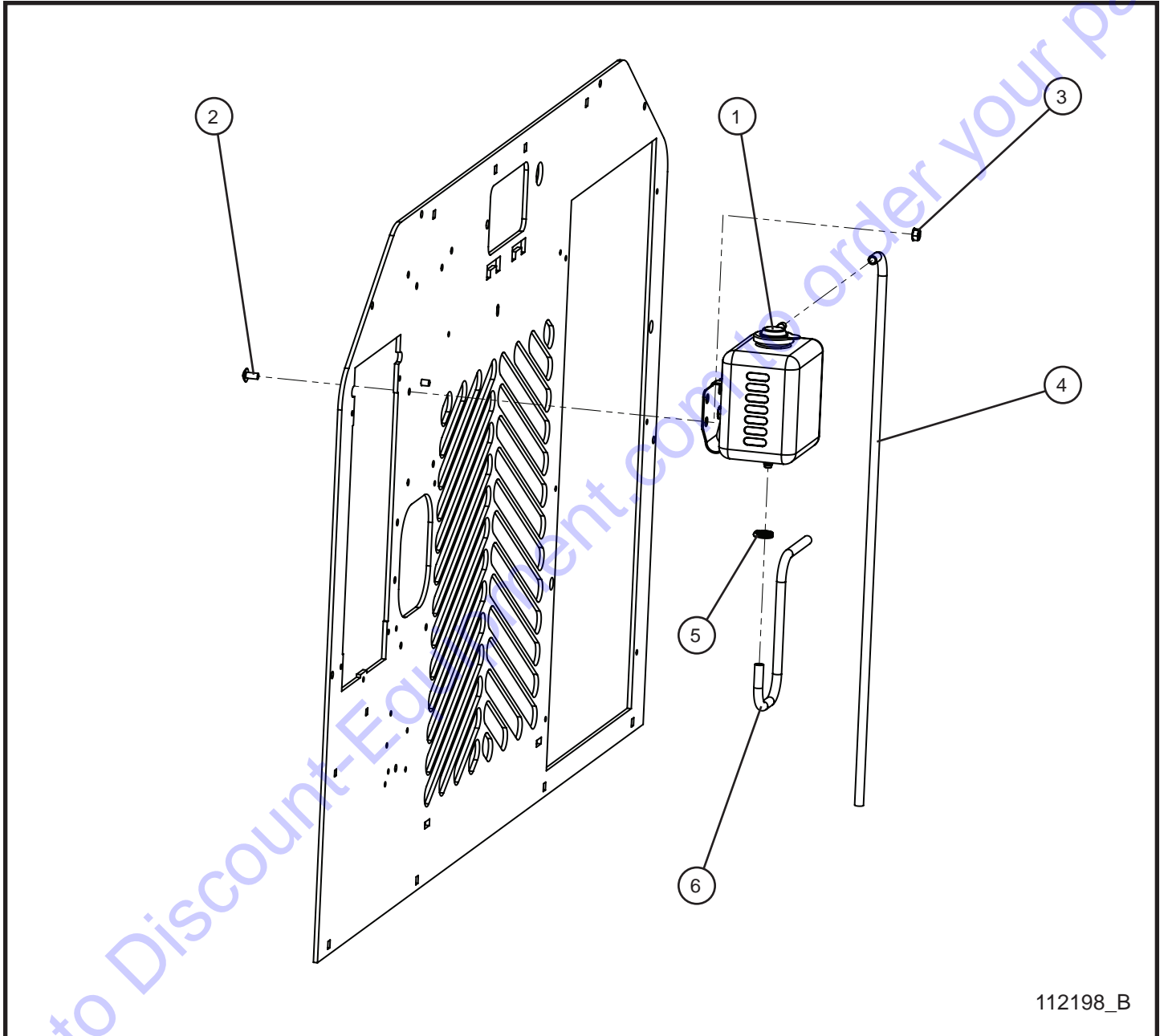

MAXI-POWER™ 15XR

SN 44-000001 and UP

5.6 - Radiator Coolant Recovery Tank

Item	Part No.	Part Description	Qty.
1	650027	RESERVOIR WITH BRACKET	1
2	041078	1/4-20 x 1/2 PH-TRUSS HEAD MS SS	2
3	044021	1/4-20 KEPS HEX NUT PL	2
4	102268	COOLANT HOSE 1/4 x 44.0	1
5	433400	#4 HOSE CLAMP	1
6	102268	COOLANT HOSE 1/4 x 28.0	1

Go to Discount-Equipment.com to order your parts

5.7 - Radiator Coolant Drain Group

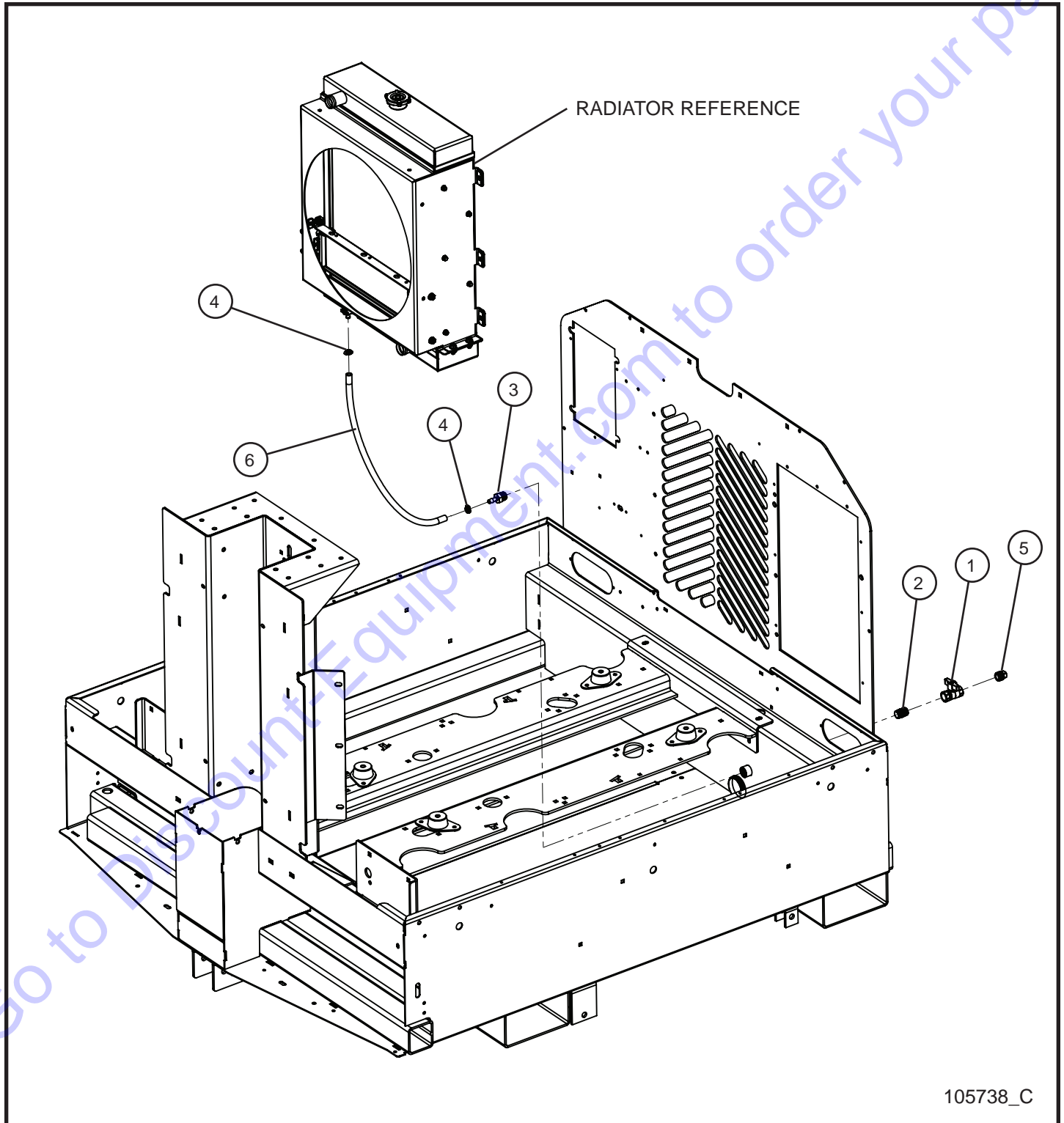

MAXI-POWER™ 15XR

SN 44-000001 and UP

5.7 - Radiator Coolant Drain Group

Item	Part No.	Part Description	Qty.
1	104133	1/2 BALL VALVE	1
2	610215	1/2 NPT NIPPLE	1
3	104381	1/2 NPT - 3/8 HOSE BARB FITTING	1
4	433400	#4 HOSE CLAMP	2
5	026106	1/2 NPT SQUARE HEAD PLUG	1
6	101266	3/8 COOLANT HOSE x 21.00 (JB/RCP RADIATOR)	1
NS	105352	DRAIN COCK	1

Go to Discount-Equipment.com to order your parts

5.8 - Radiator Cold Front Group

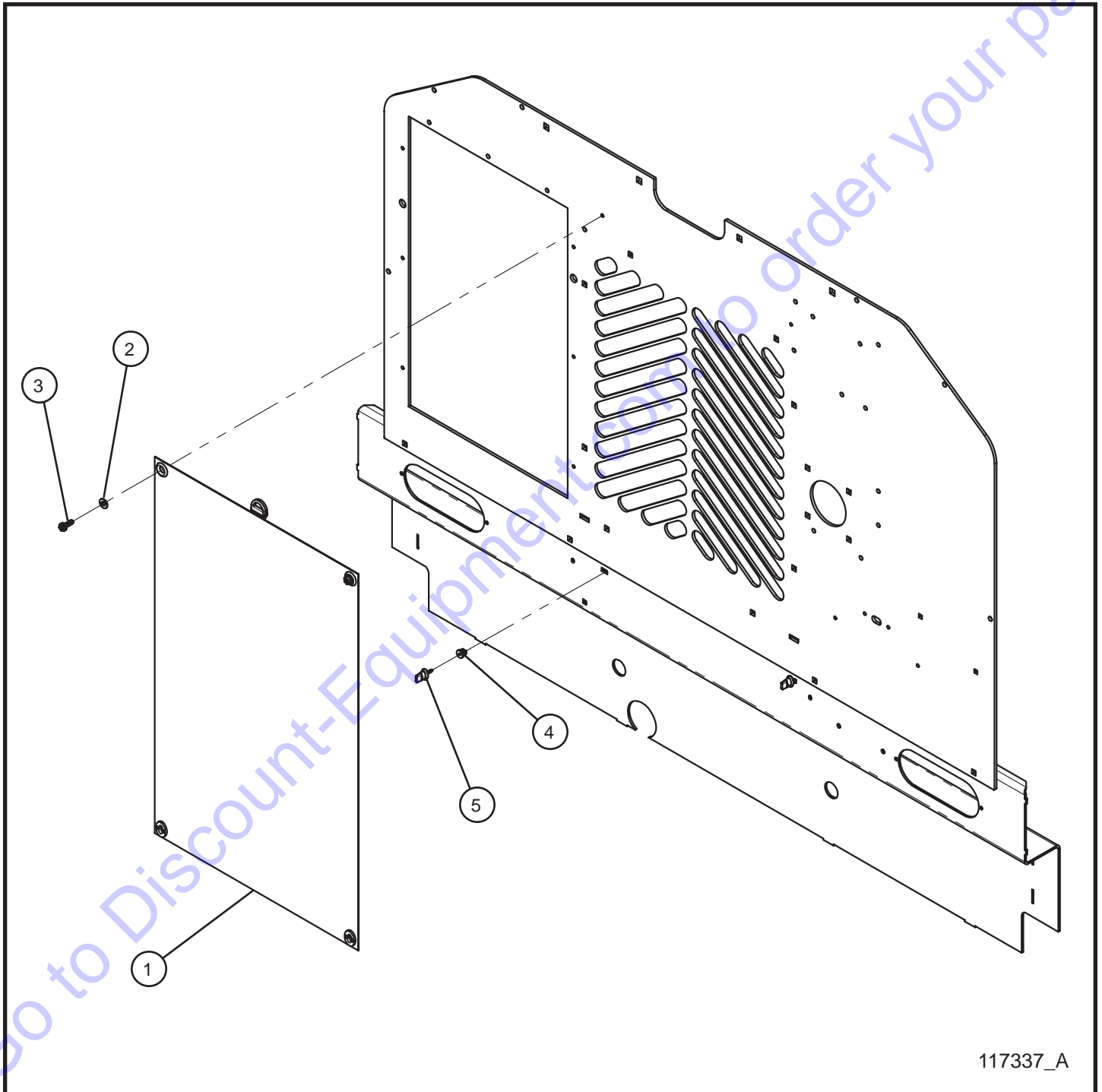

117337_A

MAXI-POWER™ 15XR

SN 44-000001 and UP

5.8 - Radiator Cold Front Group

Item	Part No.	Part Description	Qty.
1	116156	MAXI-LITE UNIVERSAL COLD FRONT	1
2	047005	1/4 FLAT WASHER	2
3	041070	1/4-20 x 3/4 SL-HEX WASHER HEAD MACHINE SCREW	2
4	106052	NYLON NUT	2
5	106056	TURN BUTTON	2
NS	116155	MAXI-LITE UNIVERSAL COLD FRONT KIT	1

Go to Discount-Equipment.com to order your parts

5.9 - Oil Drain Group

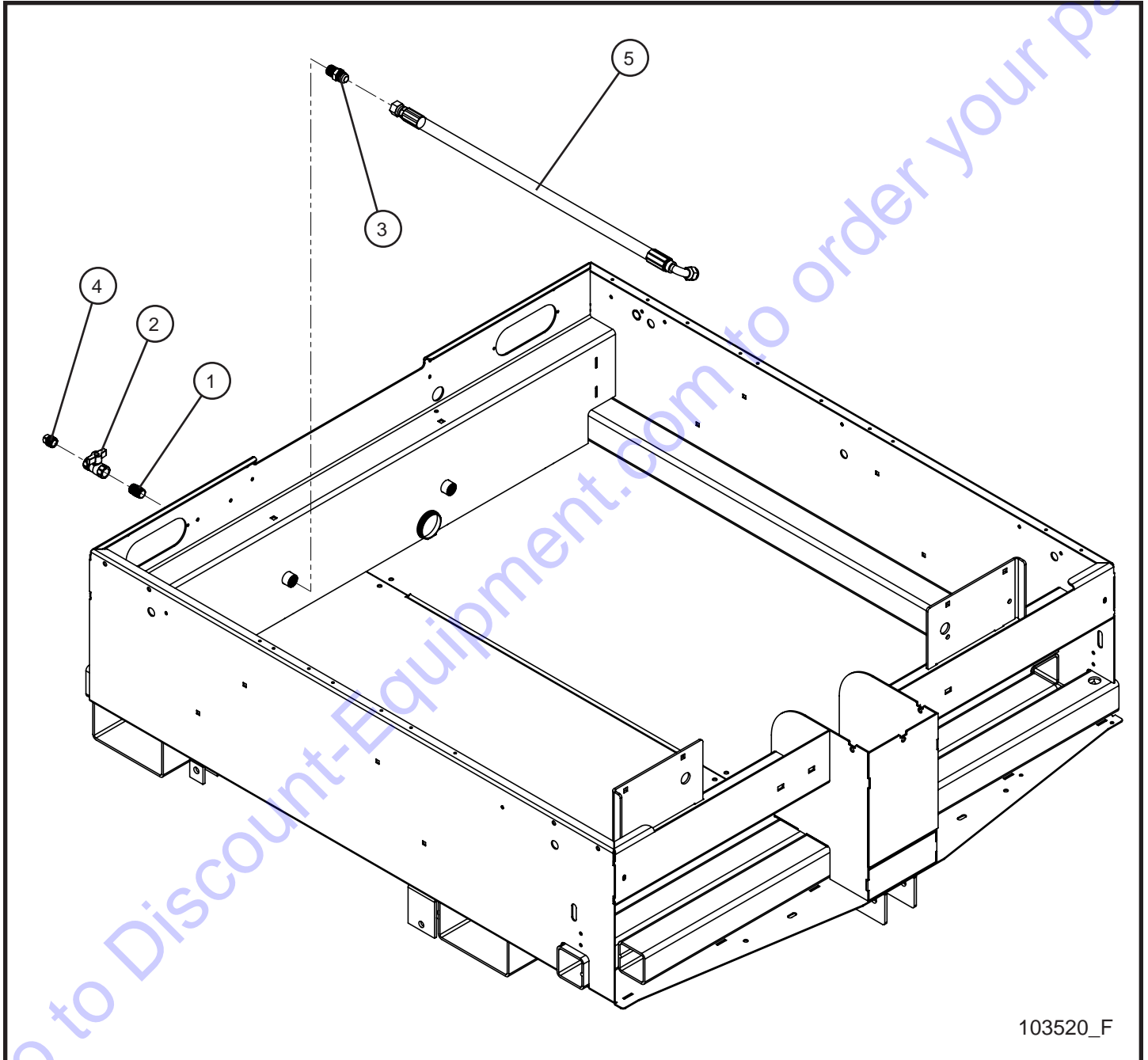

MAXI-POWER™ 15XR

SN 44-000001 and UP

5.9 - Oil Drain Group

Item	Part No.	Part Description	Qty.
1	610215	1/2 NPT NIPPLE	1
2	104133	1/2 BALL VALVE	1
3	104131	MALE ADAPTER 1/2-20 NPT #10 JIC FLARE	1
4	026106	1/2 NPT SQUARE HEAD PLUG	1
5	103325	OIL DRAIN HOSE 10TOC-10FJX-BT-10FJX90-32.5	1

Go to Discount-Equipment.com to order your parts

6.1 - CAT C1.5 Turbo Engine Assembly Group (1 of 4)

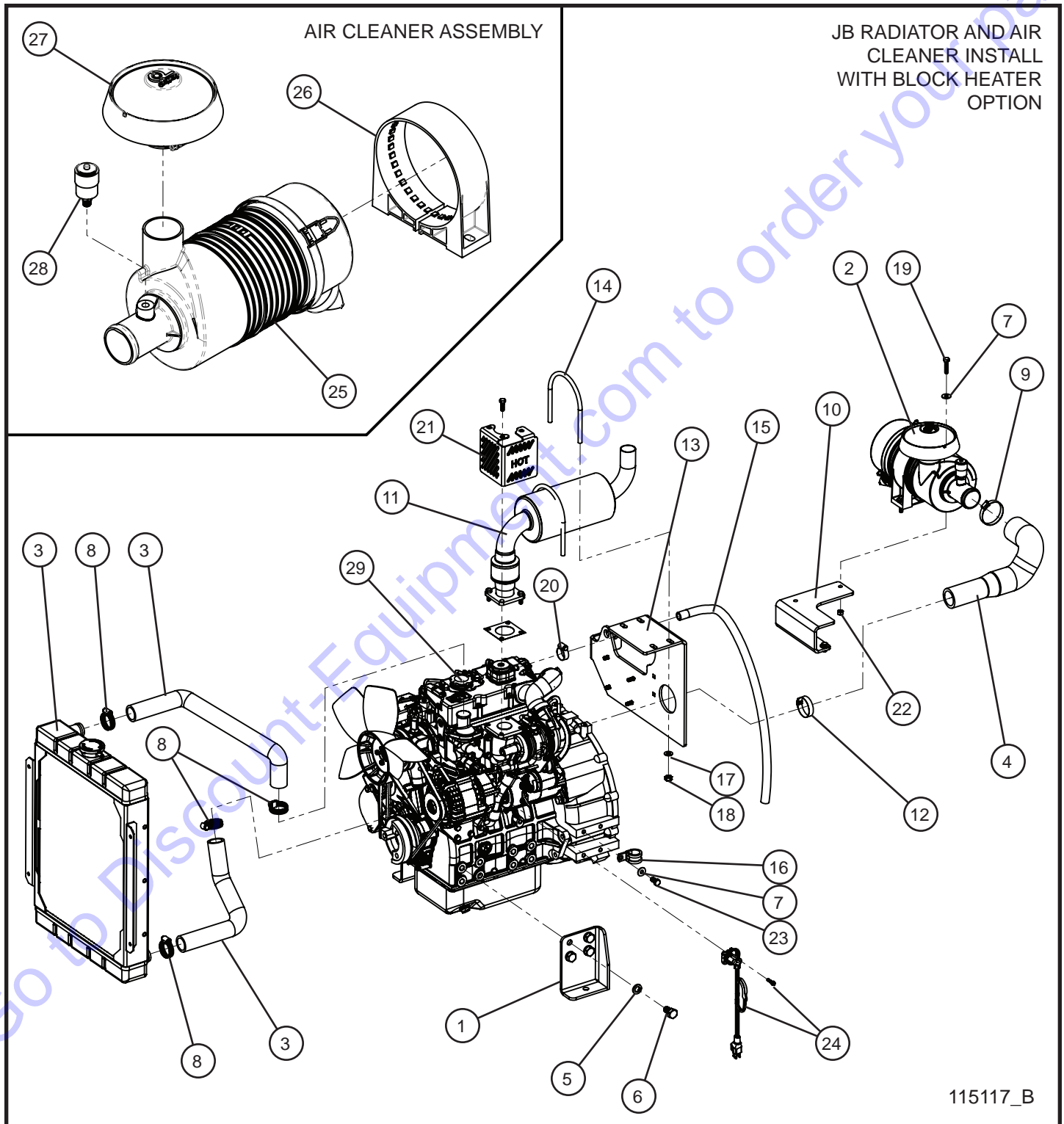

115117_B

MAXI-POWER™ 15XR

SN 44-000001 and UP

6.1 - CAT C1.5 Turbo Engine Assembly Group (1 of 4)

Item	Part No.	Part Description	Qty.
1	106218P	ENGINE RIGHT FOOT WELDMENT CAT C1.5T	1
2	106072	AIR CLEANER ASSEMBLY CAT C1.5T	1
3	106221	RADIATOR KIT JB CAT C1.5T	1
4	106073	HOSE AIR INTAKE CAT C1.5T	1
5	043095	9/16 SPLITLOCK WASHER PL	4
6	046430	M14 x 1.5 x 25 HEX HEAD CS GR8.8 PL	4
7	047010	5/16 FLAT WASHER PL	3
8	045035	#20 HOSE CLAMP	4
9	043038	#32 HOSE CLAMP	1
10	106264P	AIR CLEANER BRACKET CAT C1.5T	1
11	106252	MUFFLER CAT C1.5T	1
12	046036	#24 HOSE CLAMP	1
13	105745P	MUFFLER BRACKET CAT C1.5T	1
14	105744	4.75" MUFFLER U-BOLT	2
15	081020	HOSE J30R6 RUBBER x 26.0	1
16	022083	#16 CLAMP CUSH 3/8 HOLE	1
17	047016	3/8 FLAT WASHER SAE ZINC	4
18	044080	3/8-16 TOP LOCK HEX NUT PL	4
19	102127	8MM x 35MM x 1.25 HEX GR8.8 PLATED	2
20	045032	#12 HOSE CLAMP	1
21	106233P	FINGER GUARD TURBO CAT C1.5T	1
22	042081	M8 x 1.25MM NYLOCK HEX NUT PL METRIC	2
23	046105	3/8-16 x 3/4 HEX HEAD CS GR8 PL	1
24	103322	400W 120V 40mm BLOCK HEATER	1
25	104061	DONALDSON AIR CLEANER ASSEMBLY	1
	15-000125	PRIMARY FILTER	1
	104071	SAFETY FILTER	1
26	921140	AIR CLEANER BAND MOUNT	1
27	340032	AIR CLEANER 2" ID CAP	1
28	104795	AIR FILTER SERVICE INDICATOR KIT	1
29	104778	CAT C1.5 TURBO ENGINE 50/60Hz ELECTRONIC GOVERNOR	1
NS	106230	ELECTRONIC GOVERNOR HARNESS CAT C1.5T	1
NS	105190	HARNESS ENGINE CAT C1.5T	1
NS	105874	CAT 1.5 CHARGE CIRCUIT FUSE	1
NS	106553	SCHEMATIC CAT C1.5T ENGINE	1

6.1 - CAT C1.5 Turbo Engine Assembly Group (2 of 4)

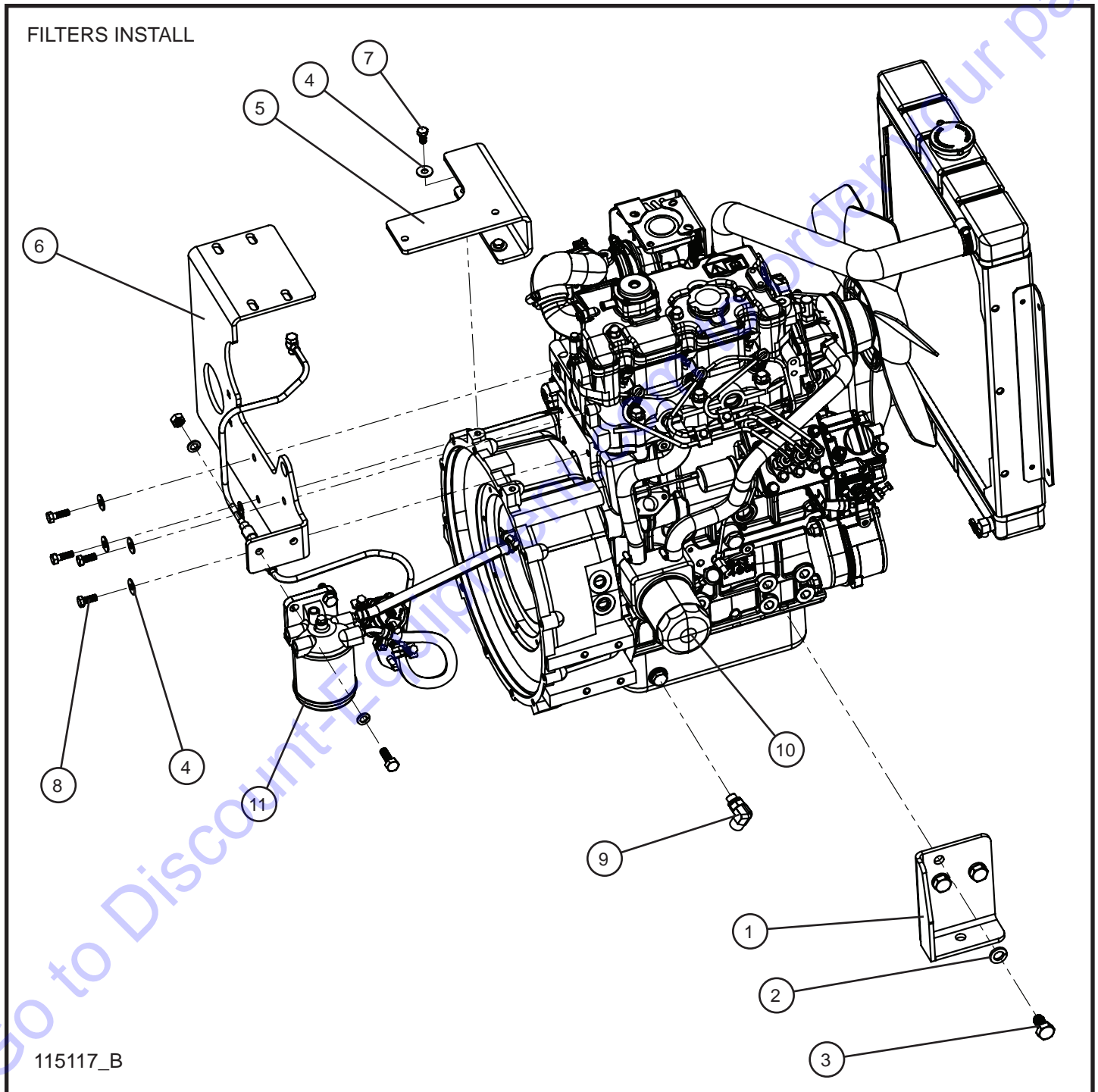

MAXI-POWER™ 15XR

SN 44-000001 and UP

6.1 - CAT C1.5 Turbo Engine Assembly Group (2 of 4)

Item	Part No.	Part Description	Qty.
1	106219P	ENGINE LEFT FOOT WELDMENT CAT C1.5T	1
2	043095	9/16 SPLITLOCK WASHER PL	3
3	046430	M14 x 1.5 x 25 HEX HEAD CS GR8.8 PL	3
4	047010	5/16 FLAT WASHER PL	6
5	106264P	AIR CLEANER BRACKET CAT C1.5T	1
6	105745P	MUFFLER BRACKET CAT C1.5T	1
7	042027	M8 x 16MM x 1.25MM HEX HEAD CS GR10.9 PL	2
8	042033	M8 x 20MM x 1.25MM HEX HEAD CS GR10.9 PL	2
9	108981	10JIC X 16mm HYDRAULIC 90° FITTING	1
10	650304	CAT C1.5T OIL FILTER	1
11	103155	CAT C1.5T FUEL FILTER	1

Go to Discount-Equipment.com to order your parts

6.1 - CAT C1.5 Turbo Engine Assembly Group (3 of 4)

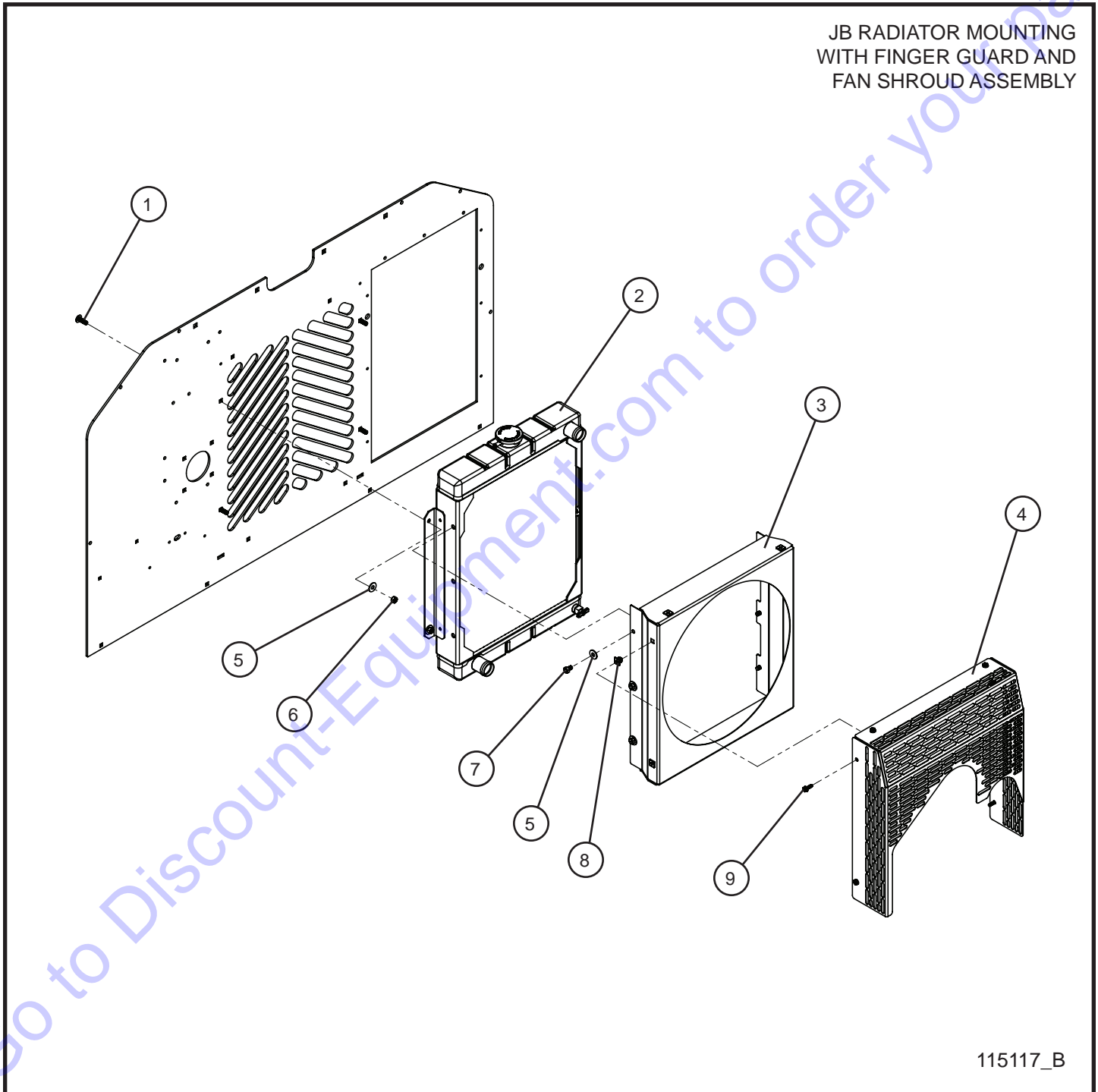

MAXI-POWER™ 15XR

SN 44-000001 and UP

6.1 - CAT C1.5 Turbo Engine Assembly Group (3 of 4)

Item	Part No.	Part Description	Qty.
1	053020	5/16-18 x 1 CARRIAGE BOLT	4
2	106221	RADIATOR KIT JB C1.5T	1
3	105739P	FAN SHROUD CAT C1.5T	1
4	105740P	FINGER GUARD CAT C1.5T	1
5	047010	5/16 FLAT WASHER PL	10
6	044033	5/16-18 NYLOCK HEX NUT PL	4
7	046046	5/16-18 x 1/2 HEX HEAD CS GR5 PL	6
8	105408	GROMMET NUT DOUBLE SPLIT	6
9	041070	1/4-20 x 3/4 SL-HEX WASHER HEAD MS TP F	6

Go to Discount-Equipment.com to order your parts

6.1 - CAT C1.5 Turbo Engine Assembly Group (4 of 4)

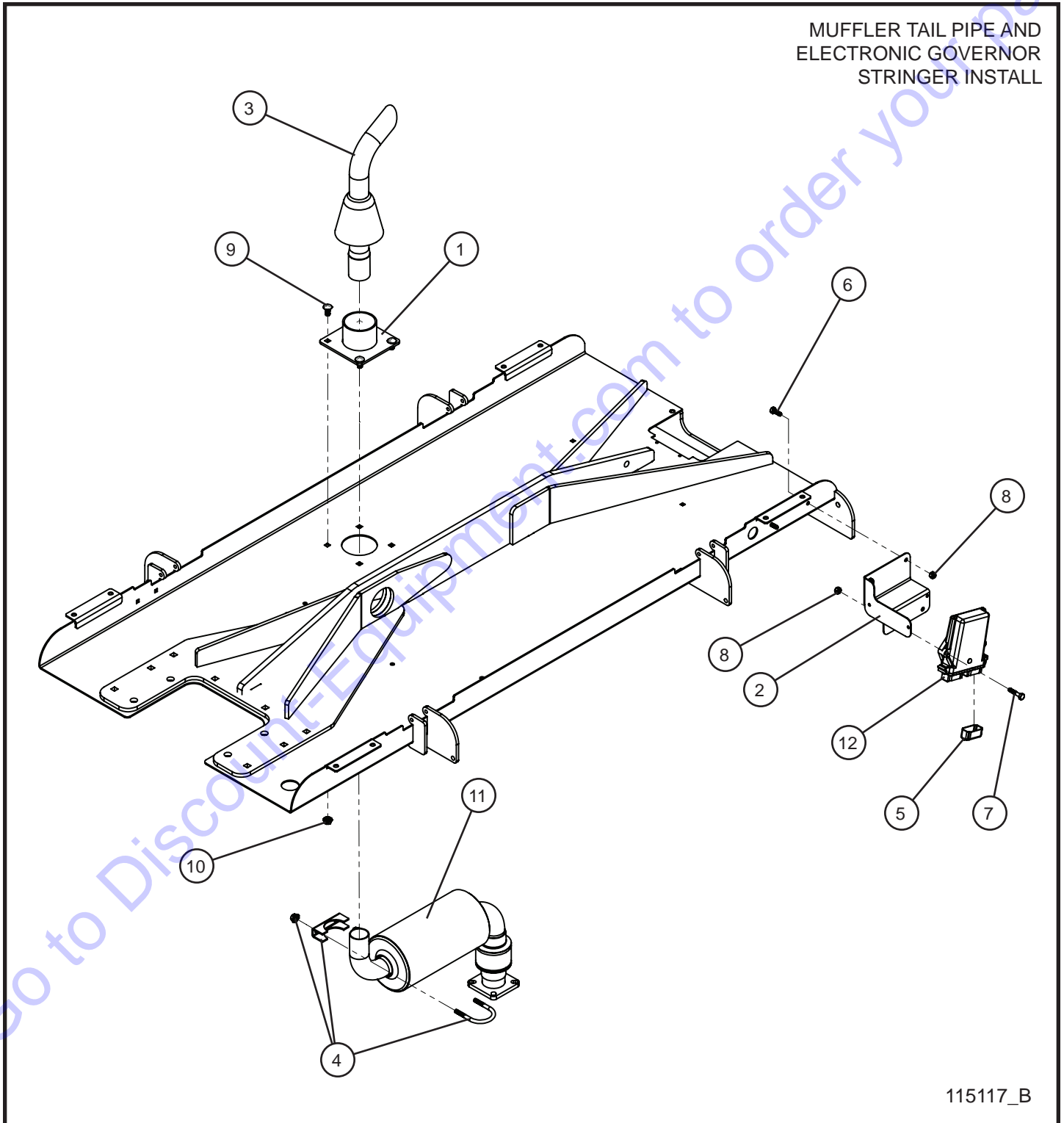

MAXI-POWER™ 15XR

SN 44-000001 and UP

6.1 - CAT C1.5 Turbo Engine Assembly Group (4 of 4)

Item	Part No.	Part Description	Qty.
1	106249P	CAT C1.5T STRINGER TOP EXHAUST WELDMENT	1
2	113476P	MAXI-LITE SHOCKER CONTROLLER BRACKET	1
3	106253	CAT C1.5T TAILPIPE VERTICAL	1
4	112211	1-5/8 EXHAUST MUFFLER CLAMP	1
5	106229	DUST CAP DTM12P-DC	1
6	046010	1/4-20 x 3/4 HEX HEAD CS GR5 SS	2
7	046020	1/4-20 x 1 1/4 HEX HEAD CS GR5 PL	2
8	044023	1/4-20 NYLOCK HEX NUT PL	4
9	102081	5/16-18 x 3/4 CARRIAGE BOLT	4
10	057006	5/16-18 SERRATED FLANGE BOLT	4
11	106252	MUFFLER CAT C1.5T	1
12	***	CAT C1.5T ELECTRONIC GOVERNOR	1

Go to Discount-Equipment.com to order your parts

6.2 - CAT C1.5 Turbo Engine Fuel Lines

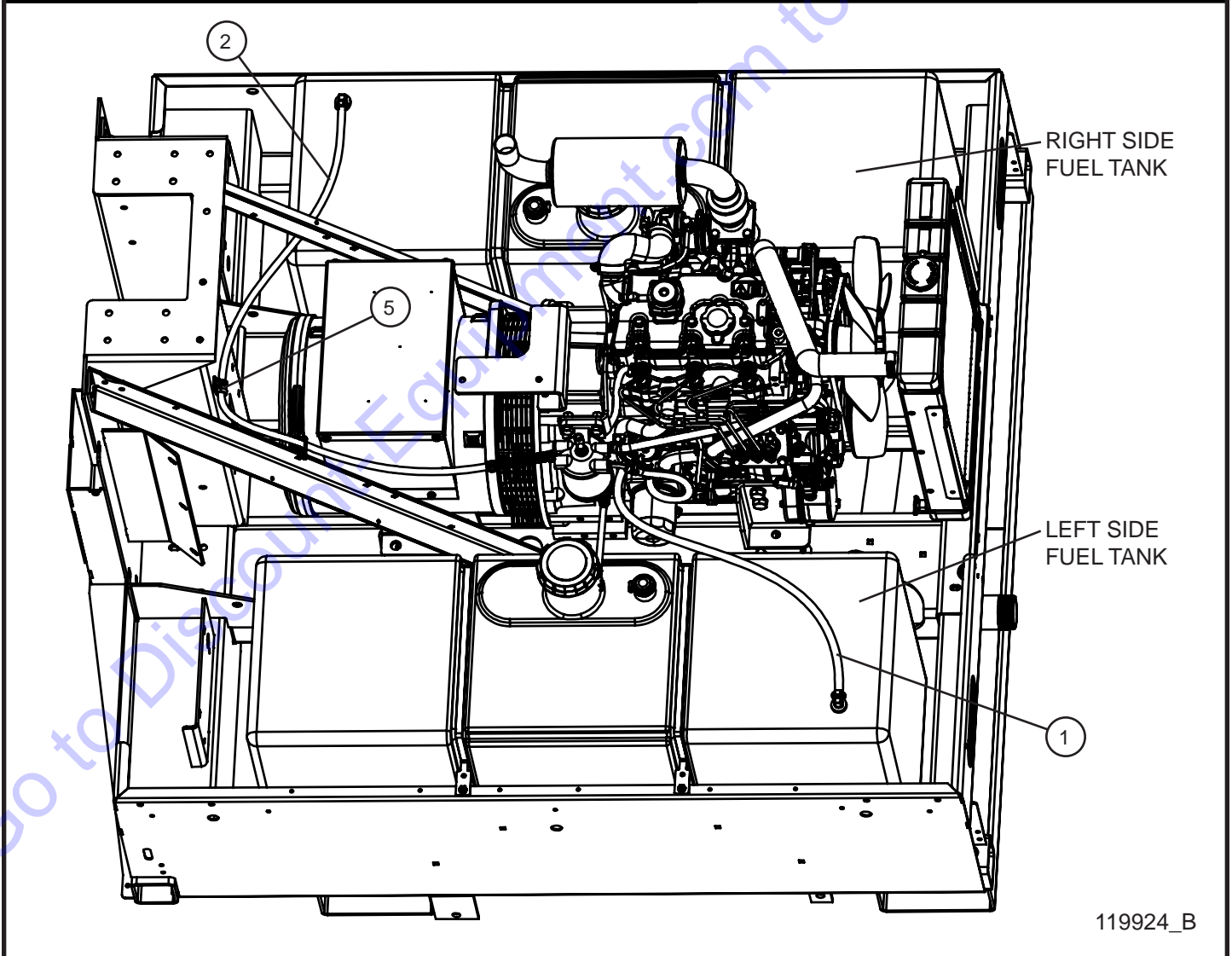
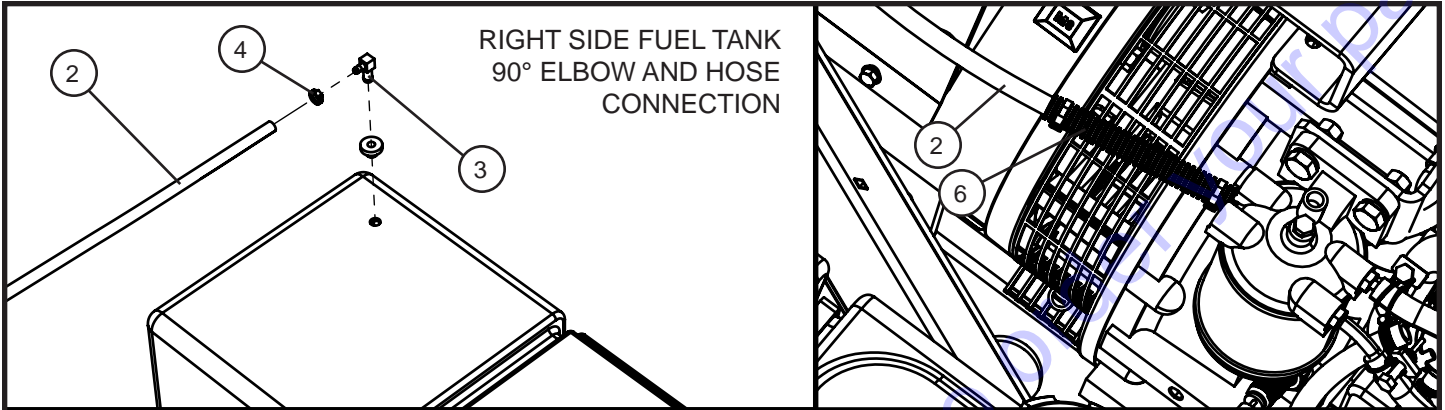

119924_B

MAXI-POWER™ 15XR

SN 44-000001 and UP

6.2 - CAT C1.5 Turbo Engine Fuel Lines

Item	Part No.	Part Description	Qty.
1	081018	HOSE 5/16 FUEL LINE x 35.00	1
2	081005	HOSE 1/4 FUEL LINE X 70.00	1
3	105106	DAPCO 90° ELBOW	1
4	433400	#4 HOSE CLAMP	4
5	022018	#8 CUSH CLAMP	1
	053020	5/16-18 X 1 CARRIAGE BOLT	1
	057006	5/16-18 SERRATED FLANGE NUT	1
6	022205	1/2" SPLIT LOOM X 5.00	1

Go to Discount-Equipment.com to order your parts

6.3 - CAT C1.5 Turbo Engine Shocker Group (1 of 2)

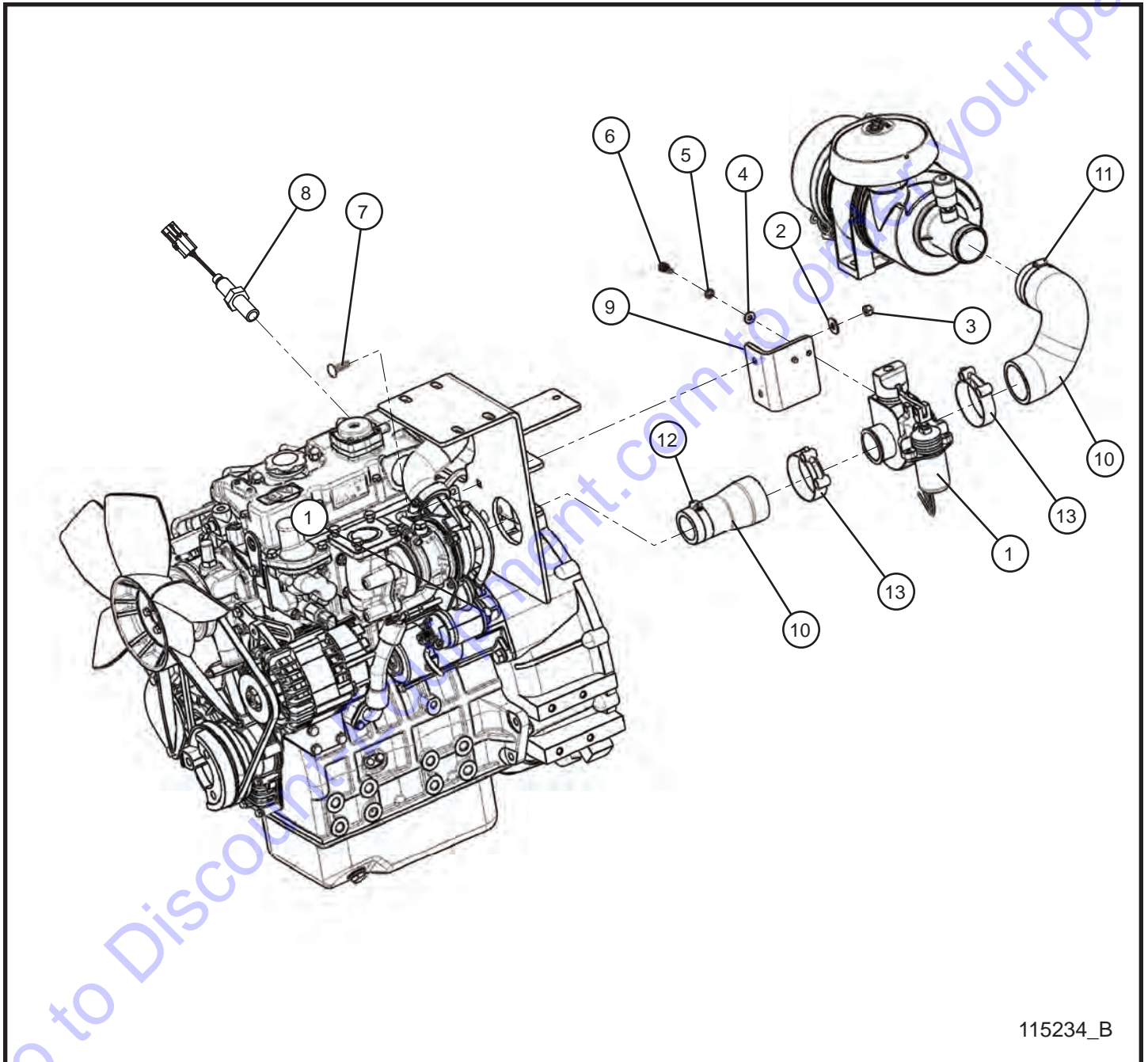

MAXI-POWER™ 15XR

SN 44-000001 and UP

6.3 - CAT C1.5 Turbo Engine Shocker Group (1 of 2)

Item	Part No.	Part Description	Qty.
1	105810	SHOCKER 2" VALVE DELPHI 3 PIN CONNECTOR	1
2	047010	5/16 FLAT WASHER	2
3	044033	5/16-18 NYLOCK HEX NUT	2
4	047005	1/4 FLAT WASHER PL	2
5	043020	1/4 SPLITLOCK WASHER	2
6	046006	1/4-20 x 5/8 HEX HEAD BOLT	2
7	053020	5/16-18 x 1 CARRIAGE BOLT PL	2
8	105536	RPM SENSOR 18mm x 1.5	1
9	106261P	BRACKET SHOCKER C1.5T	1
10	106073	HOSE AIR INTAKE CAT C1.5T	1
11	043038	#32 HOSE CLAMP	1
12	046036	#24 HOSE CLAMP	1
13	105649	2 INCH STAINLESS STEEL T-BOLT CLAMP	2
NS	105702	SHOCKER SETUP INSTRUCTIONS	1
NS	105705	SHOCKER 2" VALVE KIT	1
NS	105802	SHOCKER VALVE HARNESS	1
NS	106156	SHOCKER VALVE HARNESS SCHEMATIC	1

6.3 - CAT C1.5 Turbo Engine Shocker Group (2 of 2)

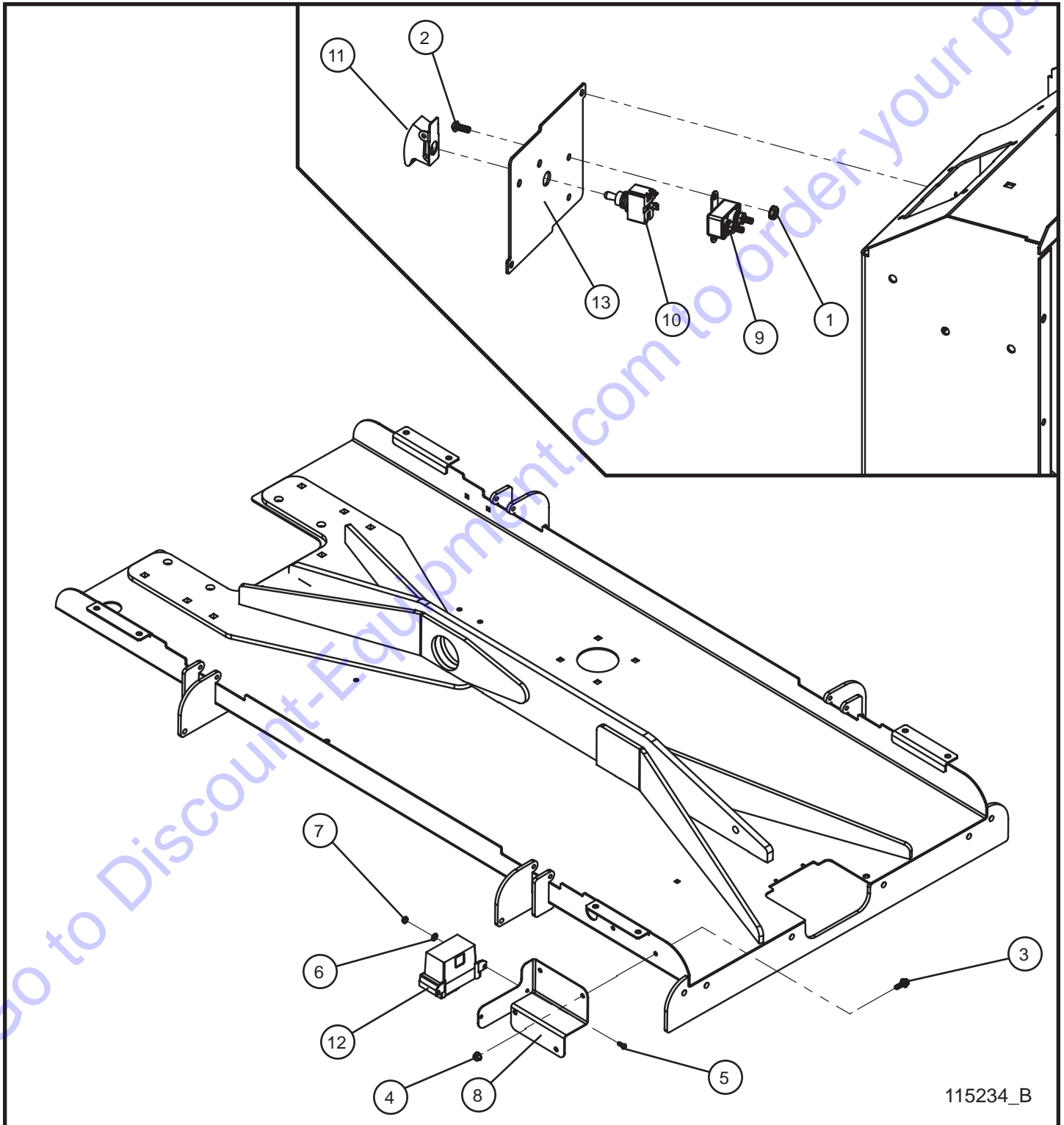

MAXI-POWER™ 15XR

SN 44-000001 and UP

6.3 - CAT C1.5 Turbo Engine Shocker Group (2 of 2)

Item	Part No.	Part Description	Qty.
1	044016	#10-24 KEPS HEX NUT	2
2	041024	#10-24 x 1/2 PH-ROUND HEAD MACHINE SCREW	2
3	056002	1/4-20 x 3/4 HEX SERRATED FLANGE SCREW	2
4	057001	1/4-20 HEX NYLOCK FLANGE NUT	2
5	041021	#10-24 x 1/2 PH-ROUND HEAD MACHINE SCREW	2
6	047070	#10 FLAT WASHER	2
7	044018	#10-24 NYLOCK HEX NUT	2
8	113476P	MAXI-LITE SHOCKER CONTROLLER BRACKET	1
9	105636	20 AMP BREAKER	1
10	340009	15A 125V ON/OFF TOGGLE SWITCH	1
11	105645	CONTROLLER PASS TOGGLE SWITCH GUARD	1
12	105692	R5 SHOCKER CONTROLLER	1
13	111228P	MAXI-LITE COMPONENT BOX BACK COVER	1
NS	105702	SHOCKER SETUP INSTRUCTIONS	1
NS	105705	SHOCKER 2" VALVE KIT	1
NS	105802	SHOCKER VALVE HARNESS	1
NS	106156	SHOCKER VALVE HARNESS SCHEMATIC	1

Go to Discount-Equipment.com to order your parts

6.4 - 15kW 1PH Marathon Generator

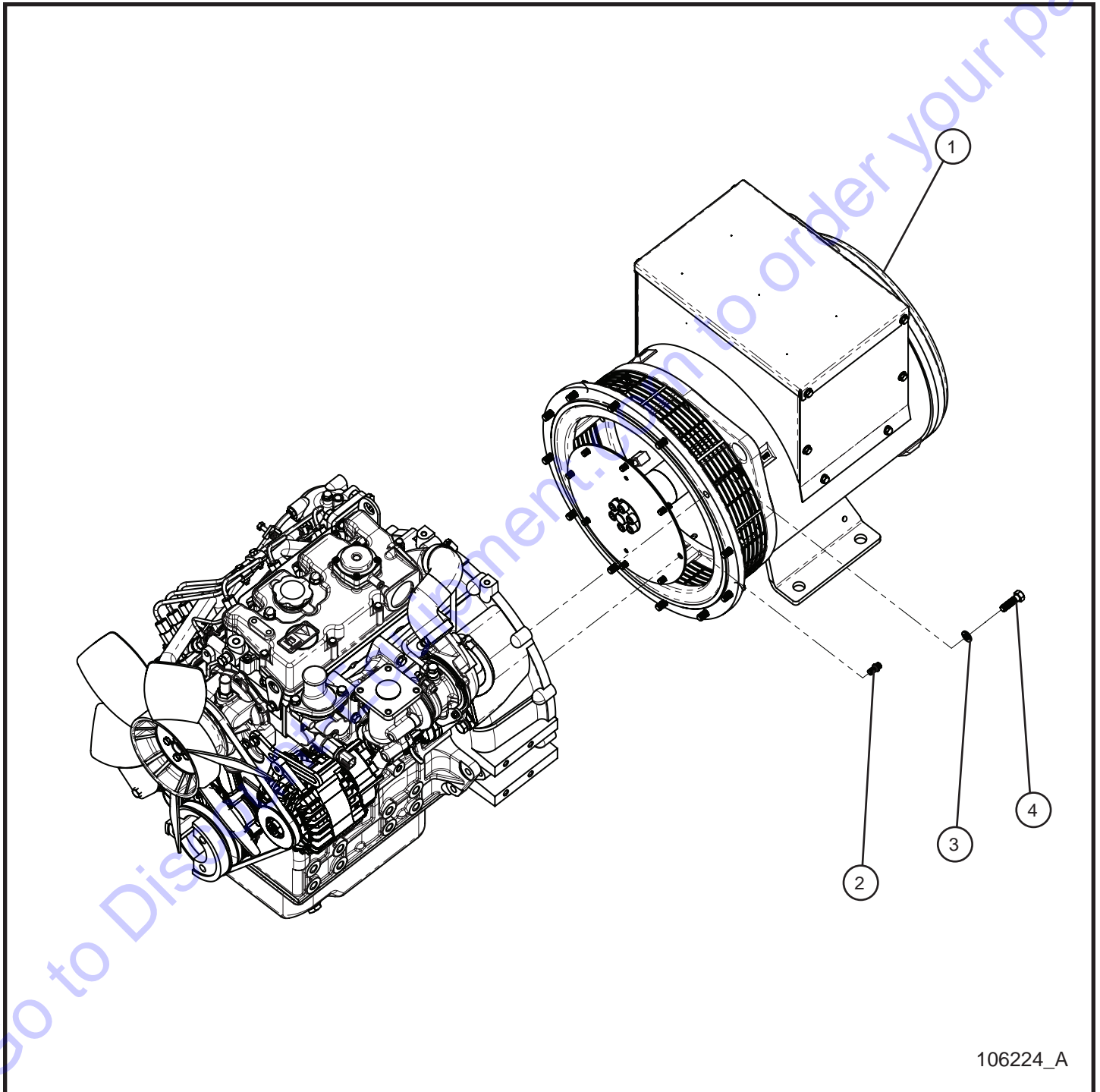

106224_A

MAXI-POWER™ 15XR

SN 44-000001 and UP

6.4 - 15kW 1PH Marathon Generator

Item	Part No.	Part Description	Qty.
1	106214	GEN MARATHON 15kW 60Hz	1
2	046041	5/16-18 x 1/2" 12 PT FLANGE HEAD BOLT	8
3	043065	3/8 SPLITLOCK WASHER PL	12
4	046115	3/8-16 x 1 1/4 HEX HEAD CS GR5 PL	12

Go to Discount-Equipment.com to order your parts

6.5 - 15kW 1PH Marathon Generator Cord Install Group

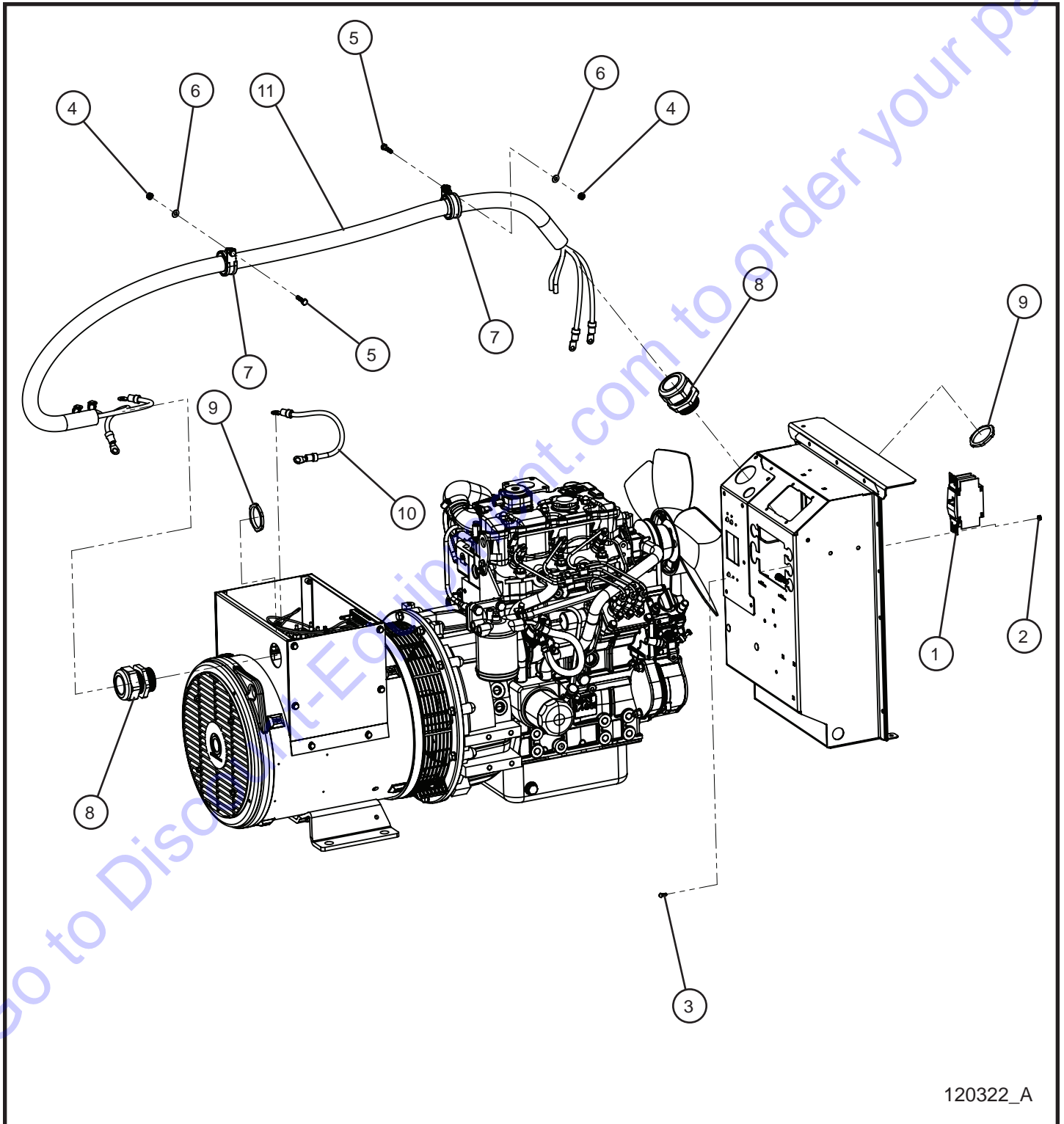

MAXI-POWER™ 15XR

SN 44-000001 and UP

6.5 - 15kW 1PH Marathon Generator Cord Install Group

Item	Part No.	Part Description	Qty.
1	353280	70 AMP DOUBLE POLE BREAKER	1
2	044003	#8-32 NC KEPS NUT	4
3	041012	#8-32 x 1/2 MACHINE SCREW	4
4	044021	1/4-20 KEPS HEX HUT	2
5	046015	1/4-20 x 1 HEX HEAD BOLT	2
6	047009	1/4 FLAT WASHER	2
7	106144	1 1/2 CUSH CLAMP W/ 3/8 HOLE	2
8	105629	1-1/2 CORD GRIP	2
9	022232	1-1/2 LOCKNUT	2
10	106067	4 AWG GREEN/YELLOW WIRE x 14.00	1
11	114472	4/4 MAXI-LITE GENERATOR CORD	1
NS	115225	11/15kW 50/60Hz 4/4 MAXI-LITE GENERATOR CORD SCHEMATIC	1

Go to Discount-Equipment.com to order your parts

7.1 - Door Branding Decals

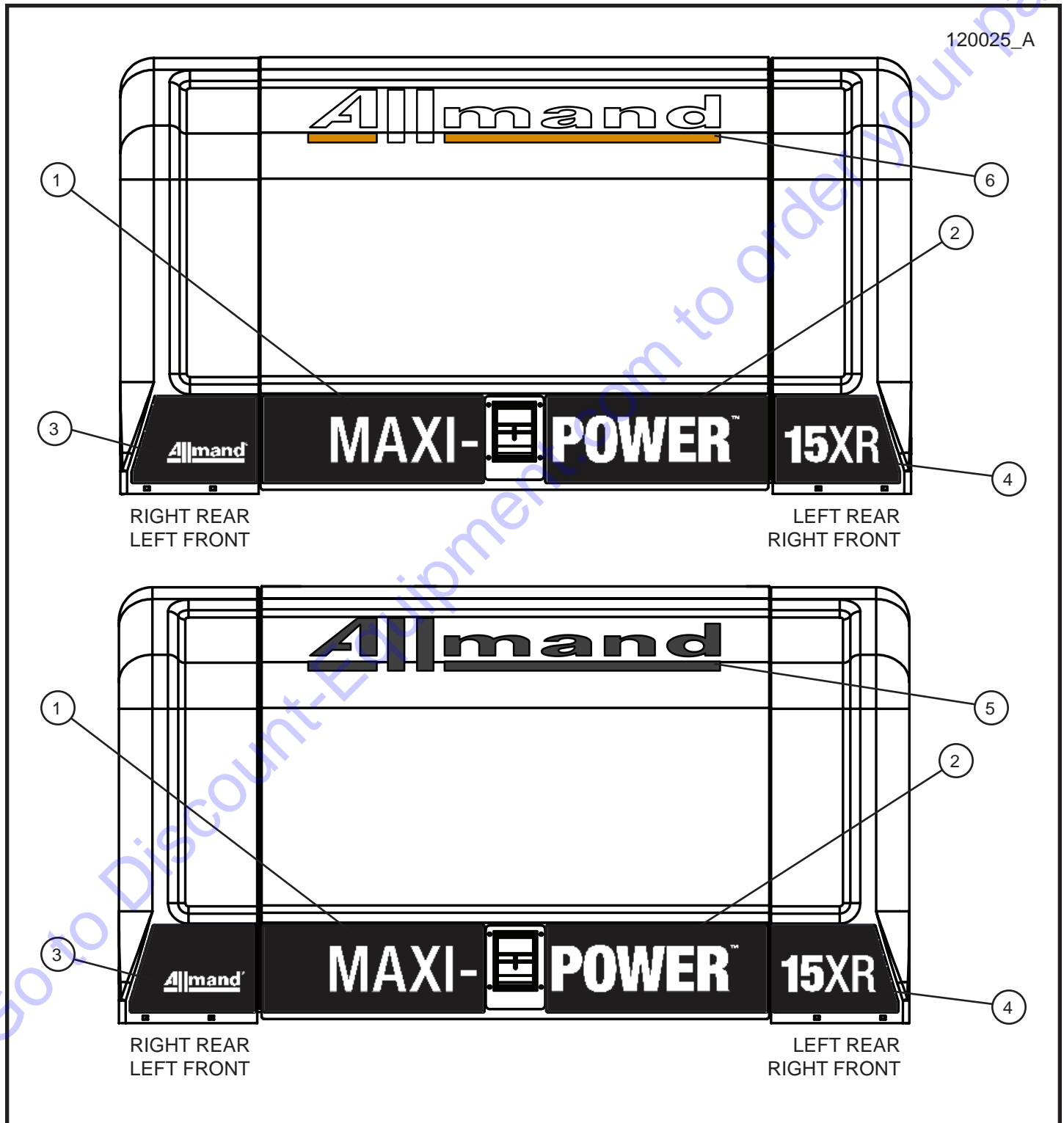

MAXI-POWER™ 15XR

SN 44-000001 and UP













7.1 - Door Branding Decals

Item	Part No.	Part Description	Qty.
1	118345	MAXI- DOOR STRIPE MAXI-POWER 15XR DECAL	2
2	118346	POWER DOOR STRIPE MAXI-POWER 15XR DECAL	2
3	118343	LEFT HAND DOOR STRIPE MAXI-POWER 15XR DECAL	2
4	118344	RIGHT HAND DOOR STRIPE MAXI-POWER 15XR DECAL	2
5	102939	ALLMAND BLACK LETTERING DOOR DECAL	2
6	110372	ALLMAND WHITE AND GOLD LETTERING DOOR DECAL	2

*NOTE: DOOR STRIPE DECALS ON THESE PAGES ARE SHOWN FOR PLACEMENT ONLY.

Go to Discount-Equipment.com to order your parts

7.2 - Domestic English Safety Decals (1 of 4)

<p>⚠ WARNING</p>  <p>Failure to follow warnings, instructions, and operator's manual could result in death or serious injury.</p>	<p>⚠ WARNING</p>  <p>Read and follow operator's manual before operating or servicing this equipment.</p>	<p>⚠ WARNING</p>  <p>Unexpected start of engine could result in death or serious injury.</p>	<p>⚠ WARNING</p>  <p>Read and follow electronic controller operator's manual before operating or servicing this equipment.</p>	<p>⚠ WARNING</p>  <p>Contact with hot exhaust gases and parts could cause serious injury.</p>	<p>⚠ WARNING</p>  <p>Contact with rotating parts could result in death or serious injury.</p>	<p>⚠ WARNING</p>  <p>Opening cap on hot radiator could result in death or serious injury.</p>	<p>⚠ WARNING</p>  <p>Allow radiator to cool down before opening cap.</p>	<p>⚠ WARNING</p>  <p>Exposure to corrosive material could result in death or serious injury.</p>	<p>⚠ WARNING</p>  <p>Wear protective gloves when handling battery.</p>	<p>⚠ WARNING</p>  <p>Smoking materials, open flames, or other forms of ignition near the battery could cause explosion resulting in death or serious injury.</p>	<p>⚠ WARNING</p>  <p>Keep smoking materials, open flames, and other forms of ignition away from the battery.</p>
<p>⚠ AVERTISSEMENT</p> <p>Consultez le manuel d'utilisation avant de faire fonctionner ou de faire l'entretien de cet équipement.</p>	<p>⚠ AVERTISSEMENT</p> <p>Le démarrage inattendu du moteur pourrait provoquer la mort ou des blessures graves.</p>	<p>⚠ AVERTISSEMENT</p> <p>Le contact avec les pièces et les gaz d'échappement chauds pourrait causer la mort ou des blessures graves.</p>	<p>⚠ AVERTISSEMENT</p> <p>Évitez les gaz d'échappement chauds. Tenir les mains et les pieds éloignés des pièces chaudes.</p>	<p>⚠ AVERTISSEMENT</p> <p>Le contact avec des pièces en mouvement pourrait résulter en de graves blessures voire la mort.</p>	<p>⚠ AVERTISSEMENT</p> <p>Si vous n'écoutez pas les pièces en mouvement, le contact avec des pièces en mouvement pourrait causer la mort ou des blessures graves.</p>	<p>⚠ AVERTISSEMENT</p> <p>Exposition à des produits corrosifs pourrait causer la mort ou des blessures graves.</p>	<p>⚠ AVERTISSEMENT</p> <p>Porter des gants de protection en manipulant la batterie.</p>	<p>⚠ AVERTISSEMENT</p> <p>Les articles de fumeur, les flammes nues ou d'autres formes d'allumage près de la batterie pourraient causer une explosion, causant la mort ou des blessures graves.</p>	<p>⚠ AVERTISSEMENT</p> <p>Tenir les articles de fumeur, les flammes nues ou les autres formes d'allumage à l'écart de la batterie.</p>		

1

NOTICE

Neutral bonded to frame.

Machine to be grounded in accordance with requirements as outlined by local inspection authorities.

AVIS

Neutre mis à la masse à la carcasse du moteur.

L'appareil doit être mis à la terre conformément aux exigences des services d'inspection locaux.

122470



122480

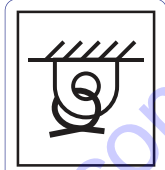

109005

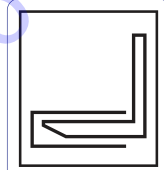

107254

5 2

LEFT SIDE

LIFT RING DETAIL



3

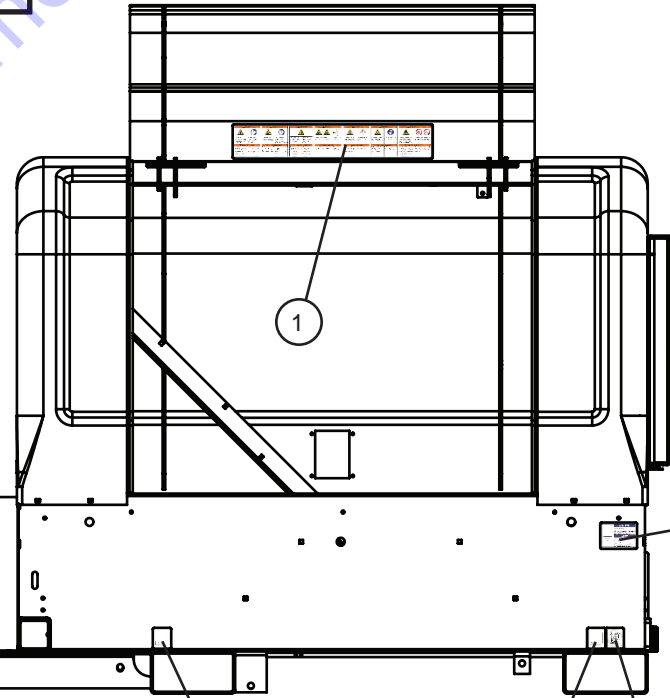

1

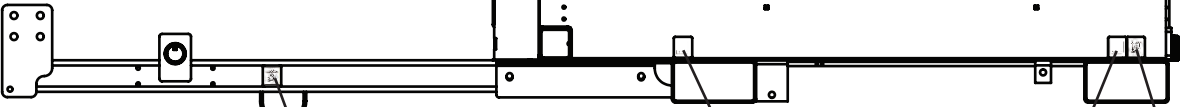

4

5 2 5

120026_A

MAXI-POWER™ 15XR

SN 44-000001 and UP

7.2 - Domestic English Safety Decals (1 of 4)

Item	Part No.	Part Description	Qty.
1	107246	DECAL MULTIPLE WARNINGS DOOR	1
2	107254	FORKLIFT POSITION DECAL	2
3	122480	DECAL LIFT HOOK	2
4	122470	DECAL NOTICE NEUTRAL BONDED & GROUNDED	1
5	109005	TIE DOWN POSITION DECAL	2

Go to Discount-Equipment.com to order your parts

7.2 - Domestic English Safety Decals (2 of 4)

⚠ WARNING	⚠ WARNING	⚠ WARNING	⚠ WARNING	⚠ WARNING	⚠ WARNING	⚠ WARNING
Failure to follow warnings, instructions, and operator's manual could result in death or serious injury.	Read and follow operator's manual before operating or servicing this equipment.	Unexpected start of engine could result in death or serious injury.	Contact with hot exhaust gases and parts could cause serious injury.	Contact with rotating parts could result in death or serious injury.	Opening cap on hot radiator could result in death or serious injury.	Exposure to corrosive material could result in death or serious injury.
⚠ AVERTISSEMENT	⚠ AVERTISSEMENT	⚠ AVERTISSEMENT	⚠ AVERTISSEMENT	⚠ AVERTISSEMENT	⚠ AVERTISSEMENT	⚠ AVERTISSEMENT
L'omission de respecter les avertissements, les instructions et le manuel de l'utilisateur pourrait entraîner des blessures graves ou la mort.	Lire et suivre le manuel d'utilisation avant de faire fonctionner ou de faire l'entretien de cet équipement.	Le démarrage inattendu du moteur pourrait provoquer la mort ou des blessures graves.	Toucher contact avec les pièces et les gaz d'échappement chauds pourrait causer la mort ou des blessures graves.	Le contact avec des pièces en mouvement pourrait entraîner en de graves blessures voire la mort.	L'ouverture du bouchon sur un radiateur chaud pourrait causer la mort ou des blessures graves.	Une exposition à des produits corrosifs pourrait causer la mort ou des blessures graves.

RIGHT SIDE

TOP OF TONGUE

109005
 4

107254
 2

118108
 1

120026_A

MAXI-POWER™ 15XR

SN 44-000001 and UP

7.2 - Domestic English Safety Decals (2 of 4)

Item	Part No.	Part Description	Qty.
1	118108	EXCESSIVE TOW SPEED WARNING ENGLISH/FRENCH DECAL	1
2	107254	FORKLIFT POSITION DECAL	2
3	107246	DECAL MULTIPLE WARNINGS DOOR	1
4	109005	TIE DOWN POSITION DECAL	2

Go to Discount-Equipment.com to order your parts

7.2 - Domestic English Safety Decals (3 of 4)

<div data-bbox="142 457 620 661"> <p>WARNING Opening cap on hot radiator could result in death or serious injury. Allow radiator to cool down before opening cap.</p> <p>AVERTISSEMENT L'ouverture du bouchon sur un radiateur chaud pourrait causer la mort ou des blessures graves. Laisser le radiateur refroidir avant de dévisser le bouchon.</p> <p>118651</p> </div> <p>5</p>	<div data-bbox="706 457 885 661"> <p>107973</p> </div> <p>1</p>	<div data-bbox="998 457 1177 661"> <p>104752</p> </div> <p>3</p>	<div data-bbox="1299 457 1477 661"> <p>104750</p> </div> <p>2</p>
<div data-bbox="142 814 332 1249"> <p>MAXI-POWER 15XR</p> <p>123248</p> </div> <p>4</p>	<p>BACK SIDE</p> <p>1 2 3 4 5</p>		

120026_A

MAXI-POWER™ 15XR

SN 44-000001 and UP

7.2 - Domestic English Safety Decals (3 of 4)

Item	Part No.	Part Description	Qty.
1	107973	OIL DRAIN DECAL	1
2	107971	DRAIN FLUID CONTAINMENT DECAL	1
3	104752	DRAIN ENGINE COOLANT DECAL	1
4	123243	DECAL QR CODE MAXI-POWER 15XR	1
5	118651	DECAL RADIATOR WARNING BI-LINGUAL	1

Go to Discount-Equipment.com to order your parts

7.2 - Domestic English Safety Decals (4 of 4)

<div data-bbox="154 462 885 766"> <table border="1"> <tr> <td data-bbox="154 462 365 598"> <p>⚠ WARNING Failure to follow warnings, instructions, and operator's manual could result in death or serious injury.</p> <p>Read and follow operator's manual before operating or servicing this equipment.</p> </td> <td data-bbox="292 472 365 598"> </td> <td data-bbox="365 462 527 598"> <p>⚠ AVERTISSEMENT L'omission de respecter les avertissements, les instructions et le manuel de l'utilisateur pourrait entraîner des blessures graves ou la mort.</p> <p>Lire et suivre le manuel d'utilisation avant de faire fonctionner ou de faire l'entretien de cet équipement.</p> </td> <td data-bbox="527 462 649 598"> <p>⚠ WARNING Breathing diesel engine exhaust exposes you to chemicals known to the State of California to cause cancer and birth defects or other reproductive harm.</p> </td> <td data-bbox="649 462 885 598"> <p>⚠ AVERTISSEMENT L'inspiration de gaz d'échappement du moteur vous expose à des produits chimiques connus selon l'État de Californie pour causer le cancer, des anomalies congénitales ou d'autres effets nuisibles à la reproduction.</p> </td> </tr> <tr> <td data-bbox="154 619 365 766"> <p>⚠ WARNING Engine exhaust contains carbon monoxide, a poisonous gas that could cause death or serious injury.</p> <p>Run equipment far from windows, doors and vents. Do not run equipment indoors or in partially enclosed spaces.</p> </td> <td data-bbox="292 619 365 766"> </td> <td data-bbox="365 619 527 766"> <p>⚠ AVERTISSEMENT Le moteur contient du monoxyde de carbone, un gaz toxique pouvant provoquer la mort ou de graves blessures.</p> <p>Faites tourner à l'extérieur, loin des fenêtres, des portes et des événements. Ne faites pas fonctionner à l'intérieur ni dans un espace partiellement fermé.</p> </td> <td colspan="2" data-bbox="527 598 885 766"> <ul style="list-style-type: none"> • Always start and operate the engine in a well-ventilated area. • If in an enclosed area, vent the exhaust to the outside. • Do not modify or tamper with the exhaust system. • Do not idle the engine except as necessary. <ul style="list-style-type: none"> • Toujours démarrer et faire fonctionner le moteur dans un endroit bien ventilé. • Si le moteur est utilisé dans un espace fermé, ventiler les gaz d'échappement à l'extérieur. • Ne pas modifier ni altérer le système d'échappement. • Ne pas mettre le moteur au ralenti sauf en cas de nécessité. <p>www.P65Warnings.ca.gov/diesel.</p> </td> </tr> </table> <p>122985</p> </div>	<p>⚠ WARNING Failure to follow warnings, instructions, and operator's manual could result in death or serious injury.</p> <p>Read and follow operator's manual before operating or servicing this equipment.</p>		<p>⚠ AVERTISSEMENT L'omission de respecter les avertissements, les instructions et le manuel de l'utilisateur pourrait entraîner des blessures graves ou la mort.</p> <p>Lire et suivre le manuel d'utilisation avant de faire fonctionner ou de faire l'entretien de cet équipement.</p>	<p>⚠ WARNING Breathing diesel engine exhaust exposes you to chemicals known to the State of California to cause cancer and birth defects or other reproductive harm.</p>	<p>⚠ AVERTISSEMENT L'inspiration de gaz d'échappement du moteur vous expose à des produits chimiques connus selon l'État de Californie pour causer le cancer, des anomalies congénitales ou d'autres effets nuisibles à la reproduction.</p>	<p>⚠ WARNING Engine exhaust contains carbon monoxide, a poisonous gas that could cause death or serious injury.</p> <p>Run equipment far from windows, doors and vents. Do not run equipment indoors or in partially enclosed spaces.</p>		<p>⚠ AVERTISSEMENT Le moteur contient du monoxyde de carbone, un gaz toxique pouvant provoquer la mort ou de graves blessures.</p> <p>Faites tourner à l'extérieur, loin des fenêtres, des portes et des événements. Ne faites pas fonctionner à l'intérieur ni dans un espace partiellement fermé.</p>	<ul style="list-style-type: none"> • Always start and operate the engine in a well-ventilated area. • If in an enclosed area, vent the exhaust to the outside. • Do not modify or tamper with the exhaust system. • Do not idle the engine except as necessary. <ul style="list-style-type: none"> • Toujours démarrer et faire fonctionner le moteur dans un endroit bien ventilé. • Si le moteur est utilisé dans un espace fermé, ventiler les gaz d'échappement à l'extérieur. • Ne pas modifier ni altérer le système d'échappement. • Ne pas mettre le moteur au ralenti sauf en cas de nécessité. <p>www.P65Warnings.ca.gov/diesel.</p>		<div data-bbox="958 451 1153 651"> <p>⚠ DANGER</p> <p>⚠ DANGER</p> <p>118074</p> </div> <p>2</p> <div data-bbox="966 777 1144 1018"> <p>15 kW</p> <p>60 Hz</p> <p>120/240 V</p> <p>125/63 A</p> <p>1 Ø</p> <p>112130</p> </div> <p>1</p>	<div data-bbox="1226 451 1485 756"> <p>113929</p> </div> <p>4</p>
<p>⚠ WARNING Failure to follow warnings, instructions, and operator's manual could result in death or serious injury.</p> <p>Read and follow operator's manual before operating or servicing this equipment.</p>		<p>⚠ AVERTISSEMENT L'omission de respecter les avertissements, les instructions et le manuel de l'utilisateur pourrait entraîner des blessures graves ou la mort.</p> <p>Lire et suivre le manuel d'utilisation avant de faire fonctionner ou de faire l'entretien de cet équipement.</p>	<p>⚠ WARNING Breathing diesel engine exhaust exposes you to chemicals known to the State of California to cause cancer and birth defects or other reproductive harm.</p>	<p>⚠ AVERTISSEMENT L'inspiration de gaz d'échappement du moteur vous expose à des produits chimiques connus selon l'État de Californie pour causer le cancer, des anomalies congénitales ou d'autres effets nuisibles à la reproduction.</p>								
<p>⚠ WARNING Engine exhaust contains carbon monoxide, a poisonous gas that could cause death or serious injury.</p> <p>Run equipment far from windows, doors and vents. Do not run equipment indoors or in partially enclosed spaces.</p>		<p>⚠ AVERTISSEMENT Le moteur contient du monoxyde de carbone, un gaz toxique pouvant provoquer la mort ou de graves blessures.</p> <p>Faites tourner à l'extérieur, loin des fenêtres, des portes et des événements. Ne faites pas fonctionner à l'intérieur ni dans un espace partiellement fermé.</p>	<ul style="list-style-type: none"> • Always start and operate the engine in a well-ventilated area. • If in an enclosed area, vent the exhaust to the outside. • Do not modify or tamper with the exhaust system. • Do not idle the engine except as necessary. <ul style="list-style-type: none"> • Toujours démarrer et faire fonctionner le moteur dans un endroit bien ventilé. • Si le moteur est utilisé dans un espace fermé, ventiler les gaz d'échappement à l'extérieur. • Ne pas modifier ni altérer le système d'échappement. • Ne pas mettre le moteur au ralenti sauf en cas de nécessité. <p>www.P65Warnings.ca.gov/diesel.</p>									
<p>CONTROL BOX DOOR</p> <p>5</p> <p>3</p> <p>2</p> <p>1</p>		<p>CONTROL BOX BACK SIDE</p> <p>4</p> <p>2</p>										

MAXI-POWER™ 15XR

SN 44-000001 and UP

7.2 - Domestic English Safety Decals (4 of 4)

Item	Part No.	Part Description	Qty.
1	112130	DECAL ELECTRICAL INFO 15kW 60Hz 1 PHASE	1
2	118074	DECAL BILINGUAL DANGER HAZARDOUS VOLTAGE VERTICAL	2
3	122985	DECAL MULTIPLE EXHAUST WARNING MAXI POWER	1
4	113929	MAXI-LITE MAIN BREAKER DECAL	1
5	118363	OPERATION MAXI-POWER 15XR DECAL	1

Go to Discount-Equipment.com to order your parts

7.3 - International Wordless Safety Decals (1 of 4)

The image displays a collection of 18 international wordless safety decals, numbered 1 through 6, and a diagram of a machine's left side with callouts for their installation.

Decal 1 (110310): A 2x4 grid of eight safety symbols: a bee, a person with a wheel, a hand with a slash, a person with a wheel, a person with a wheel, a person with a wheel, a person with a wheel, and a hand with a slash.

Decal 2 (109005): A symbol showing a hand being struck by a falling object.

Decal 3 (107978): A yellow triangle with a circular arrow and the word "AUTO", and a blue circle with a person sitting at a control panel.

Decal 4 (122480): A symbol showing a hook with an upward arrow.

Decal 5 (107969): A symbol showing a vertical line with a horizontal bar at the bottom.

Decal 6 (107254): A symbol showing a vertical line with a horizontal bar at the bottom.

Diagram: A line drawing of the left side of a machine. Callouts 1, 2, 3, 4, 5, and 6 point to specific locations where the corresponding safety decals should be placed. Callout 4 points to a lift ring detail.

LIFT RING DETAIL: A close-up diagram of a lift ring with callout 4 pointing to a specific location on the ring.

LEFT SIDE: Text label indicating the orientation of the machine diagram.

120027_B: Reference code for the decal kit.

MAXI-POWER™ 15XR

SN 44-000001 and UP

7.3 - International Wordless Safety Decals (1 of 4)

Item	Part No.	Part Description	Qty.
1	110310	DECAL WARNING ENGINE-RADIATOR-BATTERY	1
2	107254	FORKLIFT POSITION DECAL	2
3	107978	WORDLESS LSC ENGINE WARNING DECAL	1
4	122480	DECAL LIFT HOOK	2
5	107969	GROUND POSITION DECAL	1
6	109005	TIE DOWN POSITION DECAL	2

Go to Discount-Equipment.com to order your parts

7.3 - International Wordless Safety Decals (2 of 4)

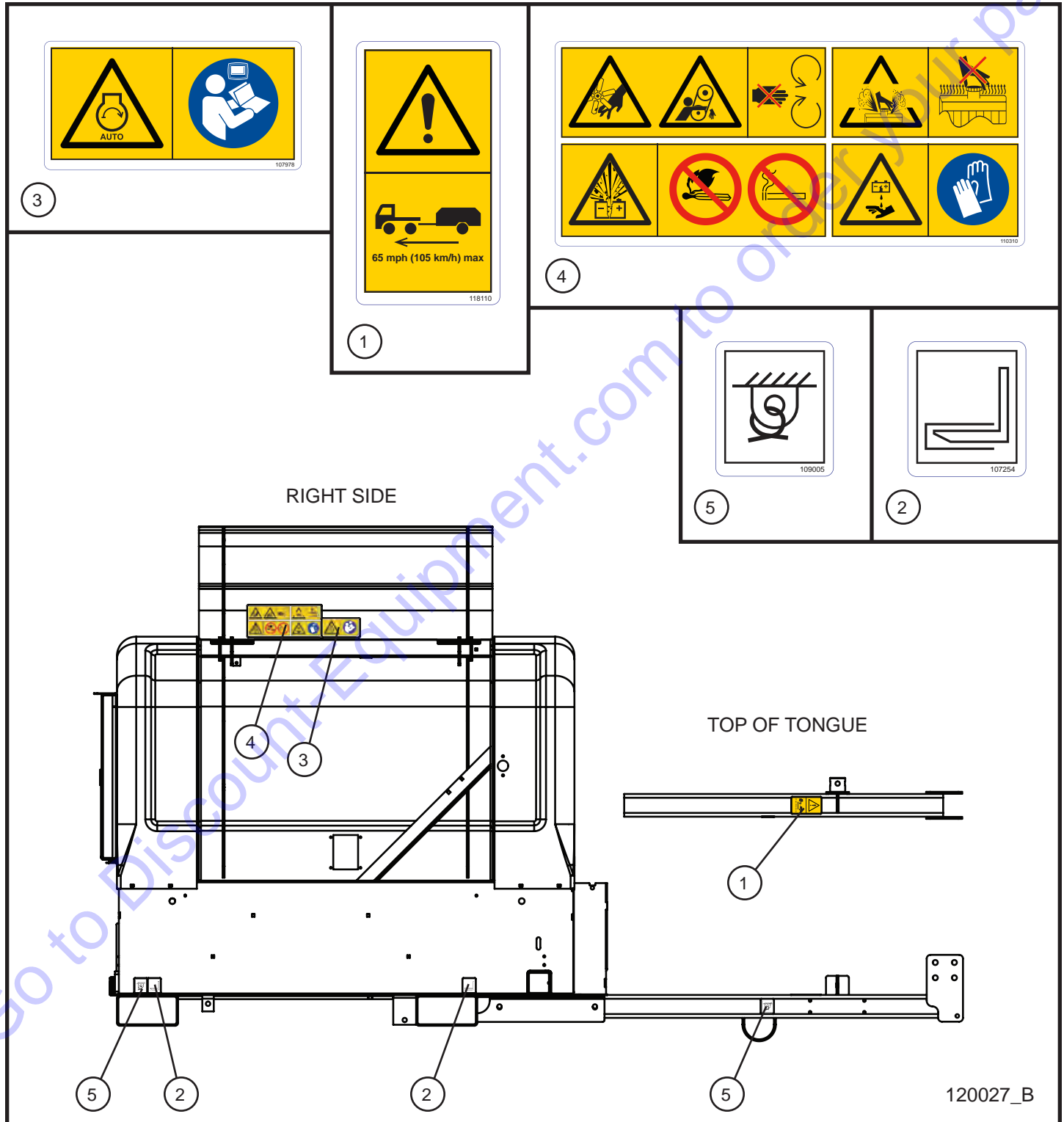

MAXI-POWER™ 15XR

SN 44-000001 and UP

7.3 - International Wordless Safety Decals (2 of 4)

Item	Part No.	Part Description	Qty.
1	118110	EXCESSIVE TOW SPEED WARNING WORDLESS DECAL	1
2	107254	FORKLIFT POSITION DECAL	2
3	107978	LSC ENGINE WARNING WORDLESS DECAL	1
4	110310	ENGINE-RADIATOR-BATTERY WARNING WORDLESS DECAL	1
5	109005	TIE DOWN POSITION DECAL	2

Go to Discount-Equipment.com to order your parts

7.3 - International Wordless Safety Decals (3 of 4)

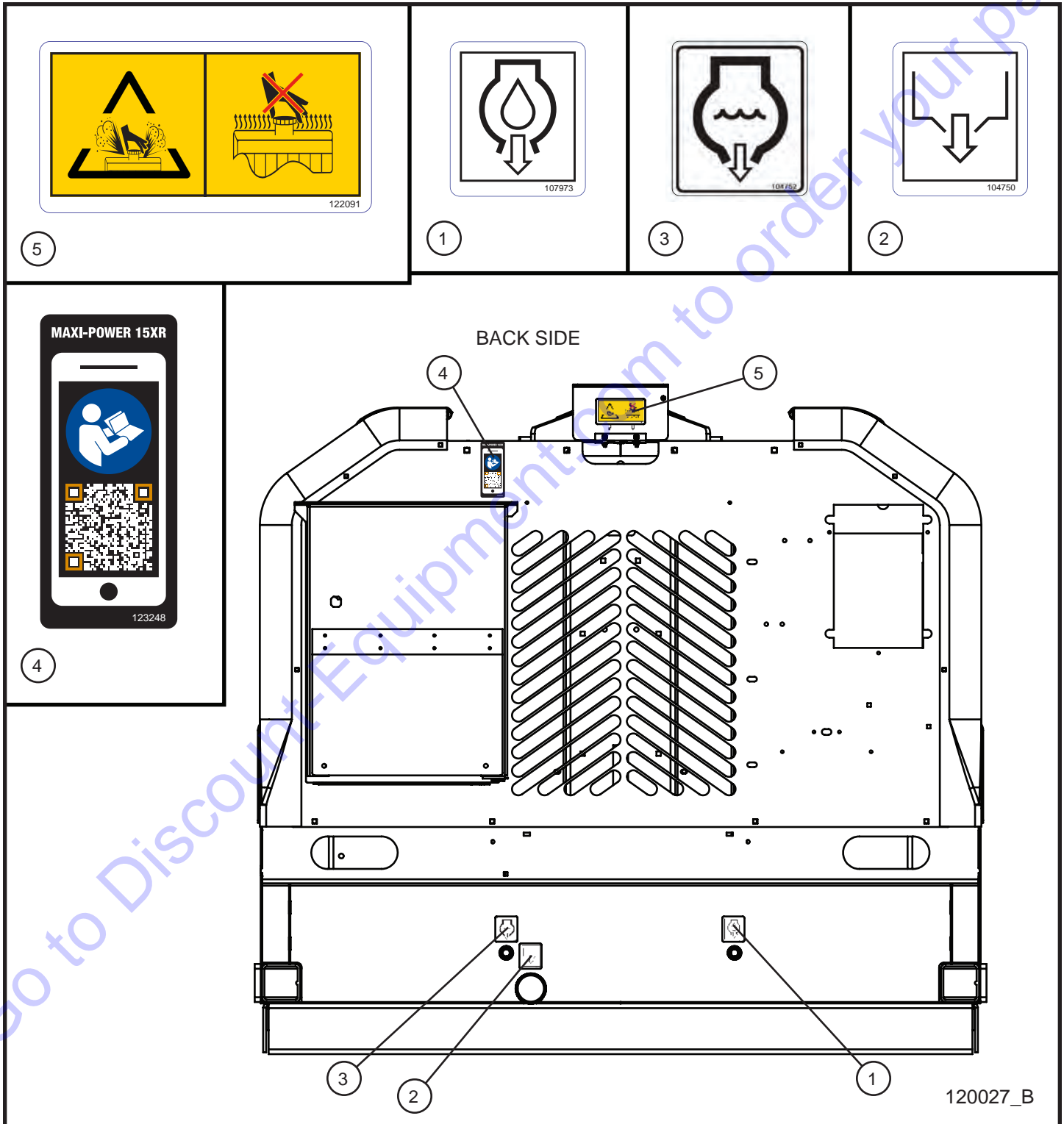

MAXI-POWER™ 15XR

SN 44-000001 and UP

7.3 - International Wordless Safety Decals (3 of 4)

Item	Part No.	Part Description	Qty.
1	107973	OIL DRAIN DECAL	1
2	107971	DRAIN FLUID CONTAINMENT DECAL	1
3	104752	DRAIN ENGINE COOLANT DECAL	1
4	123243	DECAL QR CODE MAXI-POWER 15XR	1
5	122091	RADIATOR WARNING WORDLESS DECAL	1

Go to Discount-Equipment.com to order your parts

7.3 - International Wordless Safety Decals (4 of 4)

1

15 kW
60 Hz
120/240 V
125/63 A
1 Ø

112130

2

3

113941

4

104880

113929

CONTROL BOX DOOR

CONTROL BOX BACK SIDE

120027_B

MAXI-POWER™ 15XR

SN 44-000001 and UP

7.3 - International Wordless Safety Decals (4 of 4)

Item	Part No.	Part Description	Qty.
1	112130	DECAL ELECTRICAL INFO 15kW 60Hz 1 PHASE	1
2	104880	ELECTRICAL VOLTAGE DANGER WORDLESS DECAL	2
3	113941	EXHAUST WARNING WORDLESS DECAL	1
4	113929	MAXI-LITE MAIN BREAKER DECAL	1
5	118363	OPERATION MAXI-POWER 15XR DECAL	1

Go to Discount-Equipment.com to order your parts

7.4 - Electrical Decals

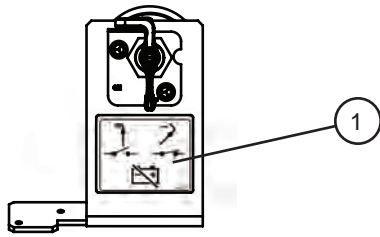

BATTERY DISCONNECT
DETAIL

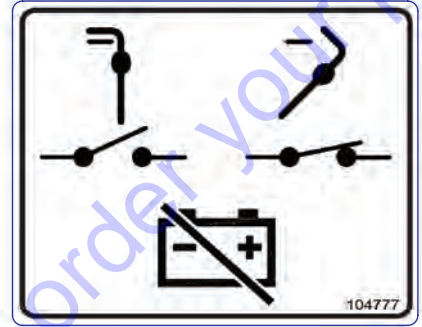

1

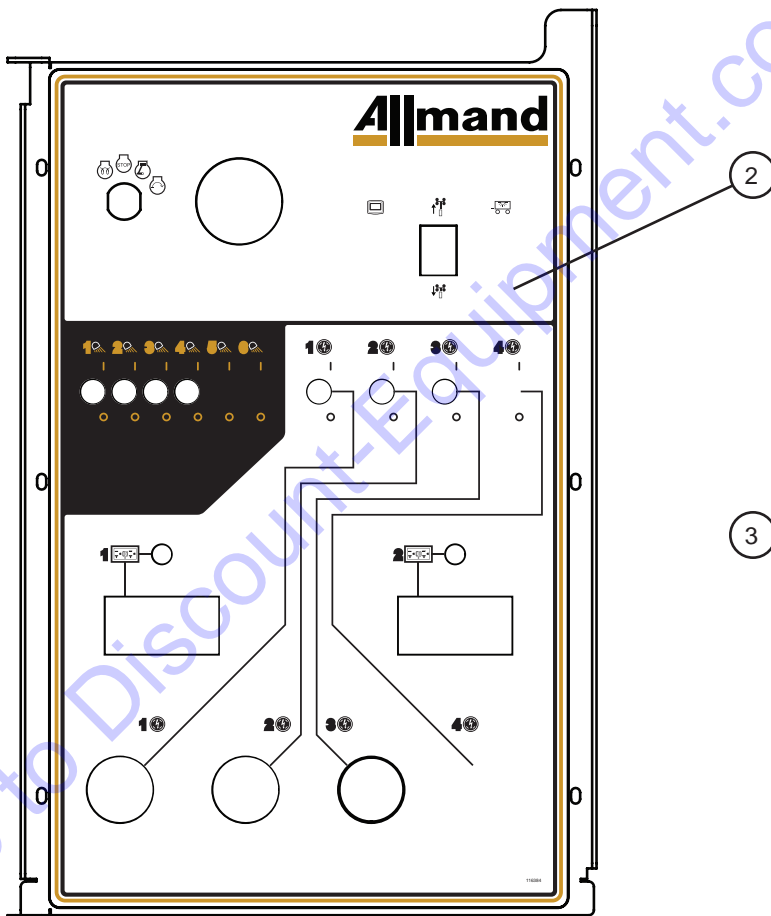

CONTROL PANEL
DETAIL



3

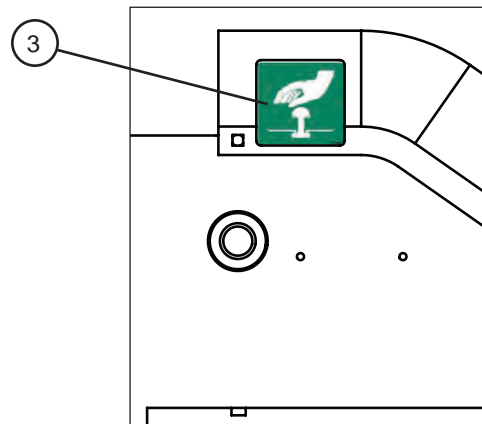

EMERGENCY STOP
DETAIL

MAXI-POWER™ 15XR

SN 44-000001 and UP

7.4 - Electrical Decals

Item	Part No.	Part Description	Qty.
1	104777	BATTERY DISCONNECT DECAL	1
2	116384	MAXI-LITE OUTLET PANEL DECAL	1
	116703	MAXI-LITE OUTLET PANEL DECAL	1
3	105567	EMERGENCY STOP DECAL	1

Go to Discount-Equipment.com to order your parts

PARTS FINDER

**Search Website
by Part Number**



**Search Manual
Library For Parts
Manual & Lookup Part
Numbers – Purchase
or Request Quote**

**Can't Find Part or
Manual? Request Help
by Manufacturer,
Model & Description**

Discount-Equipment.com is your online resource for quality parts & equipment.

Florida: **561-964-4949** Outside Florida TOLL FREE: **877-690-3101**

Need parts?

Click on this link: <http://www.discount-equipment.com/category/5443-parts/> and choose one of the options to help get the right parts and equipment you are looking for. Please have the machine model and serial number available in order to help us get you the correct parts. If you don't find the part on the website or on one of the online manuals, please fill out the request form and one of our experienced staff members will get back to you with a quote for the right part that your machine needs.

We sell worldwide for the brands: Genie, Terex, JLG, MultiQuip, Mikasa, Essick, Whiteman, Mayco, Toro Stone, Diamond Products, Generac Magnum, Airman, Haulotte, Barreto, Power Blanket, Nifty Lift, Atlas Copco, Chicago Pneumatic, Allmand, Miller Curber, Skyjack, Lull, Skytrak, Tsurumi, Husquvarna Target, Stow, Wacker, Sakai, Mi-T-M, Sullair, Basic, Dynapac, MBW, Weber, Bartell, Bennar Newman, Haulotte, Ditch Runner, Menegotti, Morrison, Contec, Buddy, Crown, Edco, Wyco, Bomag, Laymor, EZ Trench, Bil-Jax, F.S. Curtis, Gehl Pavers, Heli, Honda, ICS/PowerGrit, IHI, Partner, Imer, Clipper, MMD, Koshin, Rice, CH&E, General Equipment, Amida, Coleman, NAC, Gradall, Square Shooter, Kent, Stanley, Tamco, Toku, Hatz, Kohler, Robin, Wisconsin, Northrock, Oztec, Toker TK, Rol-Air, APT, Wylie, Ingersoll Rand / Doosan, Innovatech, Con X, Ammann, Mecalac, Makinex, Smith Surface Prep, Small Line, Wanco, Yanmar

MAXI-POWER™ 15XR

Allmand®

**Discount
Equipment**

www.discount-equipment.com

Go to Discount-Equipment.com to order your parts