

CONCRETE MIXERS

This equipment is designed for varied production capacities, handling small and large works.

Ideal for use of self-employed professionals and cement artifact companies.

- Quick and easy maintenance. *The segmented ring gear in six interchangeable pieces*, allows a better adjustment against the pinion and also economy on the replacement of the gear.
- Gravity center balanced with the chassis, assuring more efficiency and less engine efforts.
- Reinforced drum base, with 1/4" thick steel plate.
- Reinforcements on the chassis and yoke arm, increase the resistance for impacts and allow operation on uneven ground.
- Oversized dump wheel – easier to discharge material.



Reinforced structure, for heavy duty operation.



Segmented ring gear in 6 pieces.

HEAVY DUTY
11 Cu Ft



2 ½ " Tow bar, with 2" ball hitch or pintle hitch included.

**TRIPLE
BOTTOM
DRUM**



- 1 Superior Cone
- 2 Lower Cone
- 3 Drum Bottom

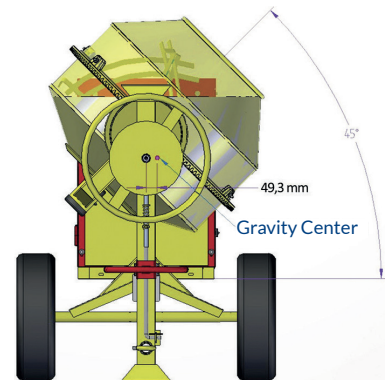

MODEL	11 Cu Ft Heavy Duty
Total Drum Volume	14 Cu Ft
Output Capacity (Mixed)	11 Cu Ft
Weight without Engine	485 Lbs
Drum Thickness	12g 5/64"
Flywheel Protection	Steel Plate
Wheels	Pneumatic Rim 14"
Towing	Tow bar for transport, with 2" ball tow hitch
Engine (optional)	Honda GX240



www.discount-equipment.com