

OWNERS MANUAL

Small Concrete Saw



Models:
C13PE
C14PEK



clipper

FORM: C13PE and C14PEK rev 3-2022

PARTS FINDER

**Search Website
by Part Number**



**Search Manual
Library For Parts
Manual & Lookup Part
Numbers – Purchase
or Request Quote**

Search Manuals

Enter your information to help us find the right parts manual for your machine.

* Brand:

* Model:

* Serial:

* Part Number:

SEARCH

**Can't Find Part or
Manual? Request Help
by Manufacturer,
Model & Description**

Parts Order Form

Please fill in the following information to help us find the right part for your machine.

Manufacturer:	<input type="text"/>
Model:	<input type="text"/>
Description:	<input type="text"/>
Part Number:	<input type="text"/>
Quantity:	<input type="text"/>
Notes:	<input type="text"/>

Discount-Equipment.com is your online resource for quality parts & equipment.

Florida: **561-964-4949** Outside Florida TOLL FREE: **877-690-3101**

Need parts?

Click on this link: <http://www.discount-equipment.com/category/5443-parts/> and choose one of the options to help get the right parts and equipment you are looking for. Please have the machine model and serial number available in order to help us get you the correct parts. If you don't find the part on the website or on one of the online manuals, please fill out the request form and one of our experienced staff members will get back to you with a quote for the right part that your machine needs.

We sell worldwide for the brands: Genie, Terex, JLG, MultiQuip, Mikasa, Essick, Whiteman, Mayco, Toro Stone, Diamond Products, Generac Magnum, Airman, Haulotte, Barreto, Power Blanket, Nifty Lift, Atlas Copco, Chicago Pneumatic, Allmand, Miller Curber, Skyjack, Lull, Skytrak, Tsurumi, Husquvarna Target, Stow, Wacker, Sakai, Mi-T-M, Sullair, Basic, Dynapac, MBW, Weber, Bartell, Bennar Newman, Haulotte, Ditch Runner, Menegotti, Morrison, Contec, Buddy, Crown, Edco, Wyco, Bomag, Laymor, EZ Trench, Bil-Jax, F.S. Curtis, Gehl Pavers, Heli, Honda, ICS/PowerGrit, IHI, Partner, Imer, Clipper, MMD, Koshin, Rice, CH&E, General Equipment, Amida, Coleman, NAC, Gradall, Square Shooter, Kent, Stanley, Tamco, Toku, Hatz, Kohler, Robin, Wisconsin, Northrock, Oztec, Toker TK, Rol-Air, APT, Wylie, Ingersoll Rand / Doosan, Innovatech, Con X, Ammann, Mecalac, Makinex, Smith Surface Prep, Small Line, Wanco, Yanmar

Table of Contents

CONTENTS	PAGE
I. Preparation	4-9
A. Safety Precautions	4-6
Dust and Silica Warning	5
B. Assembly	7
C. Specifications: C13PE and C14PEK Series Concrete Saws	8
D. Engine Precautions	9
E. Pointer Alignment	9
II. Operation	9-15
A. Blade Installation	9-10
B. Starting The Engine	10-11
C13PE 13HP Honda	10-12
C14PEK 14HP Kohler	12-14
C. Water Supply	14
D. Operating The Saw	14
E. Cutting Technique	14-15
III. Maintenance	15-26
A. Engine	15-18
C1318P Honda Powered	16-17
C1418P Kohler Powered	17-18
Dry Cutting Engine Maintenance (Honda and Kohler)	18
C. Bearings	18-19
D. V-Belts	19-23
Belt Tension C13PE and C14PEK	19-22
Belt Alignment	22
Main Causes of Belt Failures	23
E. Depth Control	24
F. Inspection and Cleaning	24
B. Wiring Diagrams C13PE and C14PEK	25-26
C1318P Honda Powered Wiring Diagram	25
C1418P Kohler Powered Wiring Diagram	26
IV. Parts List Section	27-41
A. Ordering Information	27
B. Parts Drawing and Service Parts List	28-41
Depth Control And Depth Lock Group	28-29
Blade Guard and water Control Group	30
Engine Group	31
Blade Shaft Group	32
Raise Axle Group	33
Main Frame and Belt Guard Group	34
Front Pointer Group	35
Optional Water Tank Group C13PE and C14PEK	36-37
Decals C13PE and C14PEK	38-41
Operator's Right Side C13PE and C14PEK	38-39
Operator's Left Side C13PE and C14PEK	40-41



Read Owner's Manual Before Use



Safety Alert Symbol: Information Following This Symbol Is Very Important.

Use Only Norton Diamond Blades

I. PREPARATION

A. Safety Precautions

Important! The following safety precautions must always be observed.

Hazard Symbols



Fuel (gasoline) is extremely flammable and its vapors can explode if ignited. Store gasoline only in approved containers, in well-ventilated, unoccupied approved areas, and away from sparks or flames. Do not fill the fuel tank while the engine is hot or running. Do not start the engine near spilled fuel. Never use the fuel as a cleaning agent



Engine components can get extremely hot from operation. To prevent burns, do not touch the engine or related parts while the engine is running or immediately after it is turned off. Never operate the engine with any heat shields or guards removed.



Keep all guards in place when operating any piece of equipment



Keep hands, feet, hair, and clothing away from all rotating parts



Lethal Exhaust Gas: use only in well ventilated areas. Engine exhaust gases contain poisonous carbon monoxide, which is odorless, colorless, and can cause death if inhaled. Avoid inhaling exhaust fumes, and never run the engine in a closed building or confined area.



Never tamper with the governor components of settings to increase the maximum speed. Severe personal injury and damage to the engine or equipment can result if operated at speed above maximum. Always obey the maximum speed rating of blade.



DO NOT LIFT THE SAW BY THE HANDLE BARS

WARNING

Dust and Silica Warning

Grinding/cutting/drilling of masonry, concrete, metal and other materials can generate dust, mists and fumes containing chemicals known to cause serious or fatal injury or illness, such as respiratory disease, cancer, birth defects or other reproductive harm. If you are unfamiliar with the risks associated with the particular process and/or material being cut or the composition of the tool being used, review the material safety data sheet and/or consult your employer, the material manufacturer/supplier, governmental agencies such as OSHA and NIOSH and other sources on hazardous materials and make certain to comply with all product warnings and instructions for the safe and effective use of the material being cut. California and some other authorities, for instance, have published lists of substances known to cause cancer, reproductive toxicity, or other harmful effects.

Control dust, mist and fumes at the source where possible. In this regard use good work practices and follow the recommendations of the manufacturer/supplier, OSHA/NIOSH, and occupational and trade associations. Water should be used for dust suppression when wet cutting is feasible. When the hazards from inhalation of dust, mists and fumes cannot be eliminated through engineering controls such as vacuum and/or water mist, the operator and any bystanders should always wear a respirator approved by NIOSH/MSHA for the material being cut.

Use Approved:



Eye Protection



Hearing Protection



Respiratory Protection



Head Protection

1. Before mounting any blade on the saw, the blade should be inspected for any damage which might have occurred during shipment, handling or previous use.
2. The blade collars and arbors should be cleaned and examined for damage before mounting the blade.
3. The blade must be properly fitted over the arbor with the drive pin on the outside collar projecting through the drive pin hole on the blade and inside collar.
4. The blade shaft nut, which is a left-hand thread nut, must be tightened securely against the outside blade shaft collar.
5. The blade must be operated within the specified maximum operating speed listed on the blade.
6. Turn water control valve to full to provide adequate coolant (4 to 6 gallons per minute) for diamond blades and wet cutting abrasive blades. Insufficient coolant could result in severe blade breakage or diamond segment separation.
7. The blade guard must be in place with the nose guard down and locked when the saw is running.
8. The operator should wear safety glasses and any other appropriate safety equipment.
9. When starting the saw, the operator should stand away and to the side of the blade.
10. If for any reason the saw should stall in the cut, raise the blade out of the cut. Check the outside blade shaft collar and nut for tightness. Inspect the blade for damage before restarting the saw. Use caution when resuming a cut. Be certain that the blade is in alignment with the previous cut.
11. During cutting operations do not exert excess side pressure on the handles as a method of steering. Do not force the blade into the cut by lowering the blade too fast or by pushing the saw too fast.



You Are Responsible For Your Safety!!!

I. PREPARATION

B. Assembly

The C13PE and C14PEK compact concrete saw is shipped completely assembled and ready for use except for diamond blade, gasoline, and oil. Inspect the saw for shipping damage. If any damage is found, contact the shipper immediately and file a freight claim. Norton Clipper is not responsible for any freight-related damages.

Remove the saw from the pallet. Inspect the machine for concealed shipping damaged. Read and understand ALL instruction included in this manual. Failure to understand and follow the instruction covered in this manual can result in injury or damage to the machine. Level the cutting frame and check the engine oil level and add if required (See Engine Manual) and add fuel (See Engine Manual).



C. Specifications: C13PE AND C14PEK Series Concrete Saws

	C13PE	C14PEK
Dimensions/Weight		
Length (Working)	63" (1,600mm)	63" (1,600mm)
Length (Transport)	42-3/4" (1,086mm)	42-3/4" (1,086mm)
Width	21-27/64" (544mm)	21-27/64" (544mm)
Height	38-13/16" (986mm)	38-13/16" (986mm)
Weight	220 lbs. (100 kg)	220 lbs. (100 kg)
Engine		
Engine Mfg.	Honda	Kohler
Model	GX390	CH440
Spec No.	GX390UT2QXC9	CH440-1349
Engine Type	Single Cylinder 4 Cycle	Single Cylinder 4 Cycle
Horse Power - Gross	13 hp* (9.5kW) @ 3,600 rpm	14 HP (10.5kW) @ 3,600
Max Torque – Gross	19.5 ft-lbs. (26.5 Nm) @ 2,500 rpm	22.7 ft-lbs. (30.8 Nm) @ 3,600
Cooling System	Air	Air
Oil Capacity	1.16 US qt (1.1 liter)	1.9 US qt (6.8 liter)
Fuel Capacity	1.79 US gal (6.5 liter)	1.4 US qt (1.3 liter)
Fuel Type	Unleaded Gasoline (86 pump octane)	Unleaded Gasoline (86 pump octane)
Low Oil Sensor	Yes	Yes
Air Filtration	Three Stage Cyclone	Three Stage Cyclone
Characteristics		
Max Blade	Ø18" (450 mm)	Ø18" (450 mm)
Depth of Cut	18" (406 mm)	6.75" (172 mm)
	16" (406 mm)	5.75" (146 mm)
	14" (356 mm)	4.75" (121 mm)
	12" (305 mm)	3.75" (95 mm)
Arbor Bore	1" (25.4 mm)	1" (25.4 mm)
Blade Shaft Locking Device	Machined Into Flats Of Tight Collar	Machined Into Flats Of Tight Collar
Blade Shaft Speed	2,700 rpm	2,700 rpm
Depth Control	Hand Wheel With Screw Feed	Hand Wheel With Screw Feed
Depth Lock	Standard	Standard
Depth Gauge	Customer Installed Accessory	Customer Installed Accessory
Number Of Belts	Three (3) 3VX300 Belts	Three (3) 3VX300 Belts
Blade Guard Type	Hinged, All Steel Construction	Hinged, All Steel Construction
Side of Cut	Right	Right
Lifting Bale	Yes	Yes
Water Hose Connector	Standard Garden Hose With Flow Control Valve	Standard Garden Hose With Flow Control Valve
Recessed Rear Wheels	Standard	Standard

* = Horse power and Torque ratings are Gross Horse power and are supplied by the engine manufacturer. Actual output of the engine will vary due to many factors including operational speed of engine, environmental conditions, maintenance, fuel, and other variables. Saint-Gobain Abrasives, Inc. makes NO claim to actual or gross horse power and torque ratings.

D. Engine Precautions

Prior to attempting to operate the engine, read the information contained in the engine owner's manual. An engine owner's manual is supplied with every gasoline powered concrete saw.

1. **Check Oil:** Add oil if low. Refer to the engine owner's manual for the recommended SAE viscosity grades. Capacity of oil is 1.16 US quarts (1.1 liters) for Honda GX390 powered machines and 1.9 US qt (6.8 liter) for Kohler CH440 powered machines. Verify the oil capacity with the engine owner's manual.
2. **Check Fuel:** Fill if low. Use only unleaded gasoline with a pump sticker octane rating of 86 or higher is recommended. **Never use an oil and gasoline mixture!**
3. **Air Cleaner:** Never run the engine without the air cleaner! Rapid engine wear will result from contaminants being drawn through the carburetor and into the engine.
4. **Engine Starting:** Refer to the engine owner's manual additional proper engine starting procedure.

E. Pointer Alignment

1. Use a straight edge, and carefully mark a line 12 feet long on a smooth level surface.
2. Place the saw blade on the marked line, move the saw to the center of the marked line and then lower the blade until it is about 1/16" above the marked line
3. Measure from each end of the saw frame to insure that the frame is parallel to the marked line. Adjust the saw as needed.
4. With the blade centered on the marked line and the saw frame parallel to the marked line, lower the front pointer.
5. Adjust the pointer by bending it until is aligned with the marked line.

II. OPERATION

A. Blade Installation

1. Disconnect the spark plug.
2. Remove the blade shaft nut, (Turn clockwise), and remove the outside collar.

3. Clean off any foreign particles on the clamping surfaces of both collars and on the mounting surface of the blade.
4. Place the blade on the blade shaft, lining up the drive pin hole in the blade with the drive pinhole in the inside collar.



For Best Performance Use Only Norton Diamond Blades Specified for the Material Being Cut.

5. Slide the outside blade shaft collar onto the blade shaft. The drive pin on the outside collar must project through the drive pin hole in the blade and into the inside collar.
6. Tighten the blade shaft nut (counter-clockwise) securely against the outside collar.
7. Reconnect the spark plug.

B. Starting the Engine C13PE 13HP Honda

1. Refer to the engine owner's manual for detail starting procedures.
2. Always cut with engine rpm in the full throttle setting.



Before starting, insure that the blade is properly installed, all guards are in place and in safe operating condition, and that the Blade is not in contact with any surface or object. Also verify that the area where the work is to be performed is clean, safe, and has proper ventilation and lighting. Always located and properly mark all water, gas, and electrical services before beginning any work.

3. Check Engine Oil level per the Honda Engine Manual. Add if needed. **DO NOT OVERFILL.**
4. Check Fuel Level and add fuel if needed.
 - a. Check fuel system for leaks. **DO NOT OVER FILL.**
5. Verify and clean engine cooling areas, air intake, and external surfaces of the engine.
6. Verify that the air cleaner components, all shrouds, machine blade guard, machine belt guard are in place and securely fastened.

	WARNING Carbon Monoxide can cause severe nausea, fainting or death. Avoid inhaling exhaust fumes.
	Engine exhaust gases contain poisonous carbon monoxide. Carbon monoxide is odorless, colorless, and can cause death if inhaled.

	WARNING Rotating Parts can cause severe injury. Stay away while engine is in operation.
	Keep hands, feet, hair, and clothing away from all moving parts to prevent injury. Never operate engine with covers, shrouds, or guards removed.

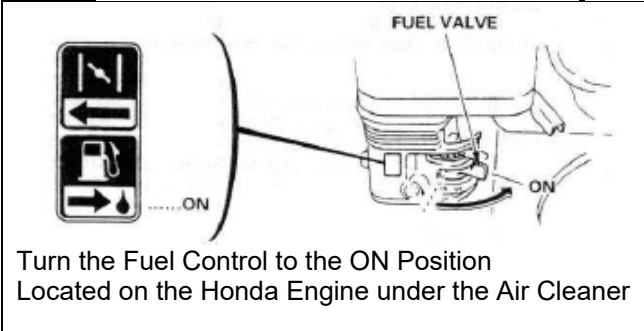

FUEL VALVE

Turn the Fuel Control to the ON Position
Located on the Honda Engine under the Air Cleaner

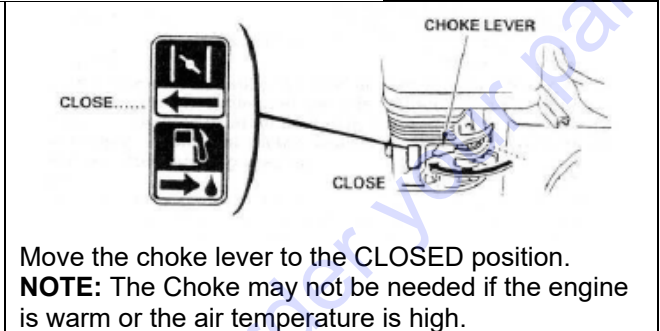

CHOKE LEVER

Move the choke lever to the CLOSED position.
NOTE: The Choke may not be needed if the engine is warm or the air temperature is high.

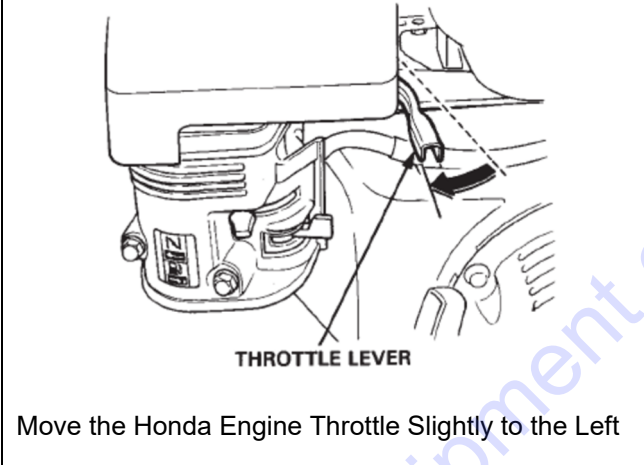

THROTTLE LEVER

Move the Honda Engine Throttle Slightly to the Left

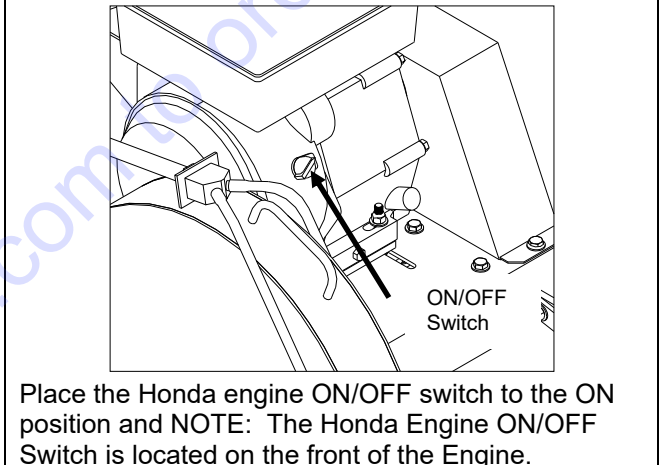

ON/OFF Switch

Place the Honda engine ON/OFF switch to the ON position and **NOTE:** The Honda Engine ON/OFF Switch is located on the front of the Engine.

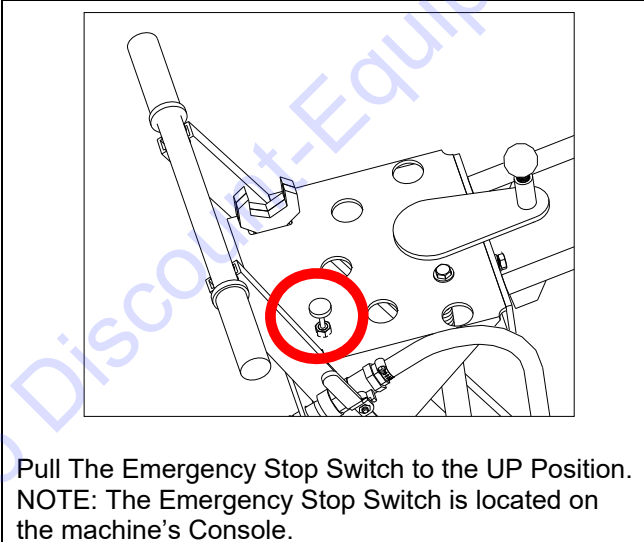

Emergency Stop Switch

Pull The Emergency Stop Switch to the UP Position.
NOTE: The Emergency Stop Switch is located on the machine's Console.

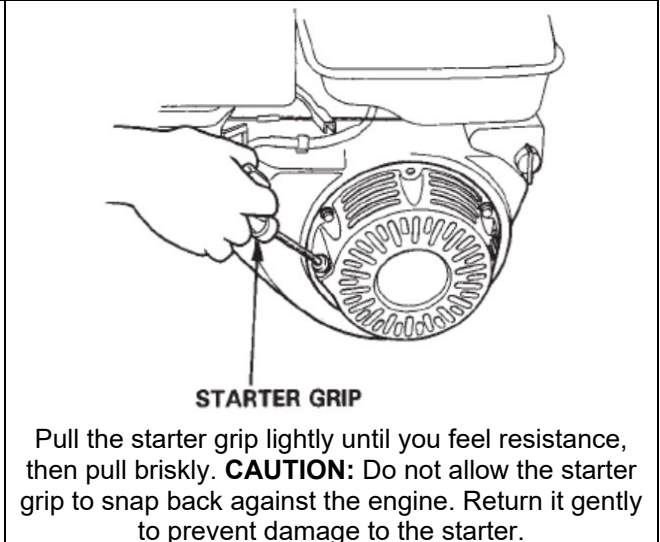

STARTER GRIP

Pull the starter grip lightly until you feel resistance, then pull briskly. **CAUTION:** Do not allow the starter grip to snap back against the engine. Return it gently to prevent damage to the starter.

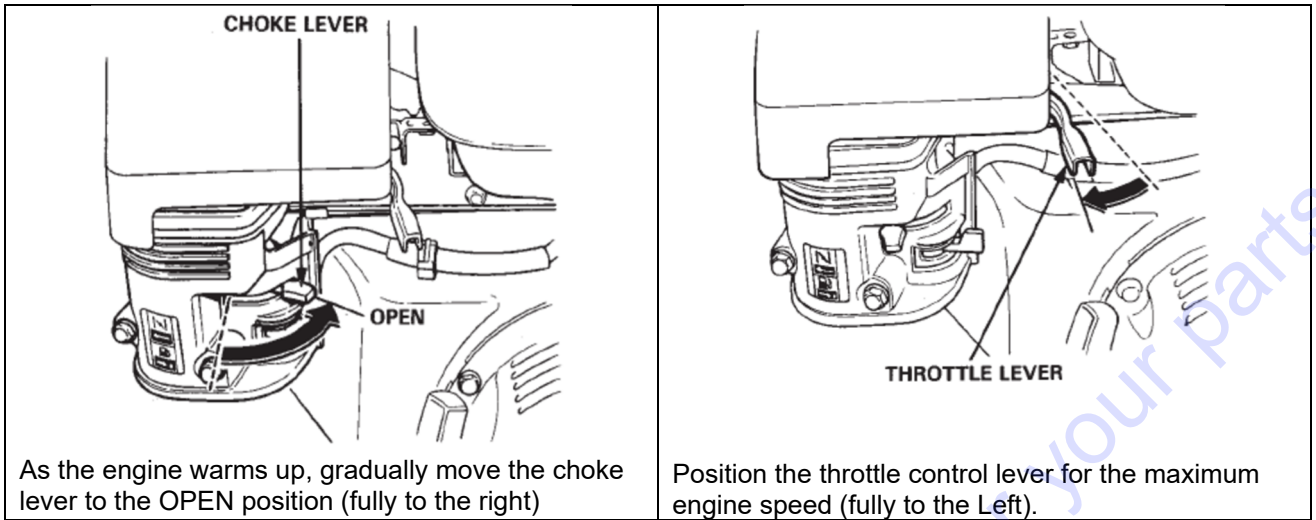



To stop the engine, move the Throttle Control Lever fully to the Forward Position (fully to the right), press the Emergency Stop Switch (Down Position), and then turn the engine switch to the OFF position. Turn the fuel valve to the OFF position.





Never transport the machine with the Fuel Valve in the ON position. Never Store the machine with the Fuel Valve in the ON position. Never Transport a machine with the blade installed.

C14PEK 14 HP Kohler

1. Refer to the engine owner's manual for detail starting procedures.
2. Always cut with engine rpm in the full throttle setting.
3. Check Engine Oil level per the Honda Engine Manual. Add if needed, DO NOT OVERFILL.
4. Check Fuel Level and add fuel if needed.
 - a. Check fuel system for leaks.
5. Verify and clean engine cooling areas, air intake, and external surfaces of the engine.
6. Verify that the air cleaner components, all shrouds, machine blade guard, machine belt guard are in place and securely fastened.

	 WARNING
	Carbon Monoxide can cause severe nausea, fainting or death. Avoid inhaling exhaust fumes.
Engine exhaust gases contain poisonous carbon monoxide. Carbon monoxide is odorless, colorless, and can cause death if inhaled.	

	 WARNING
	Rotating Parts can cause severe injury. Stay away while engine is in operation.
Keep hands, feet, hair, and clothing away from all moving parts to prevent injury. Never operate engine with covers, shrouds, or guards removed.	



Before starting, insure that the blade is properly installed, all guards are in place and in safe operating condition, and that the Blade is not in contact with any surface or object. Also verify that the area where the work is to be performed is clean, safe, and has proper ventilation and lighting. Always located and properly mark all water, gas, and electrical services before beginning any work.

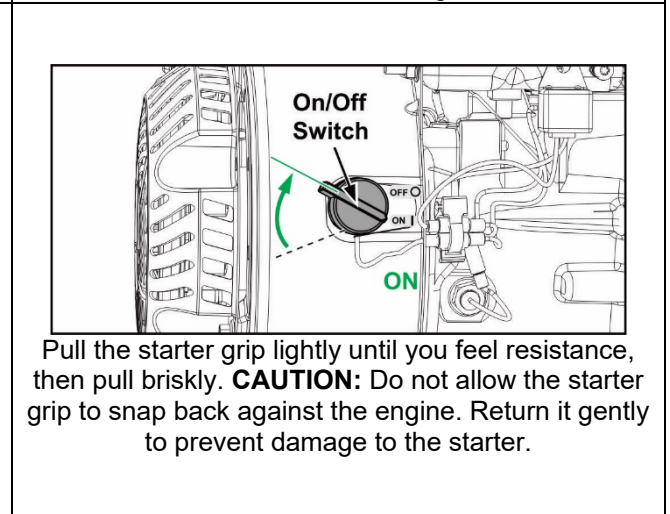
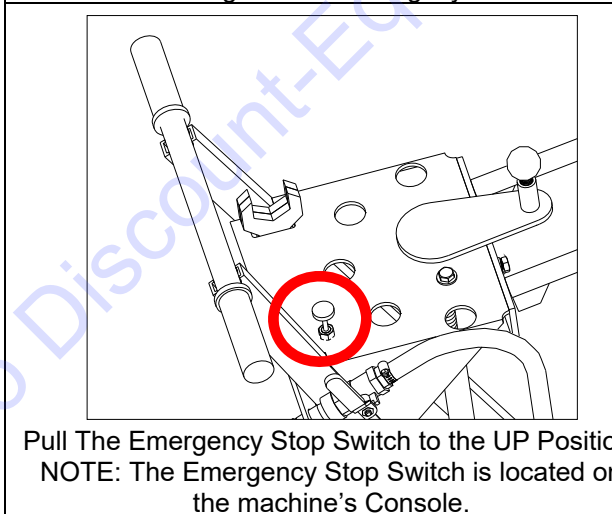
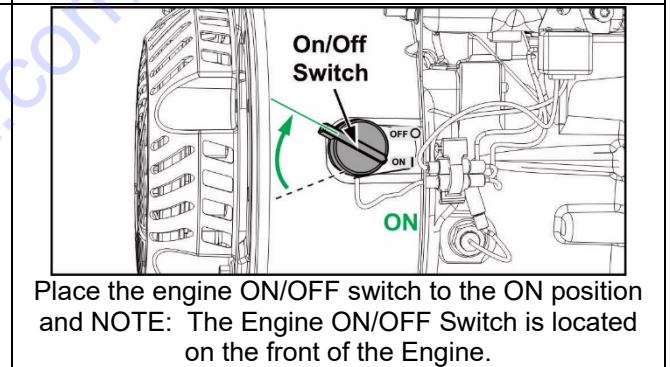
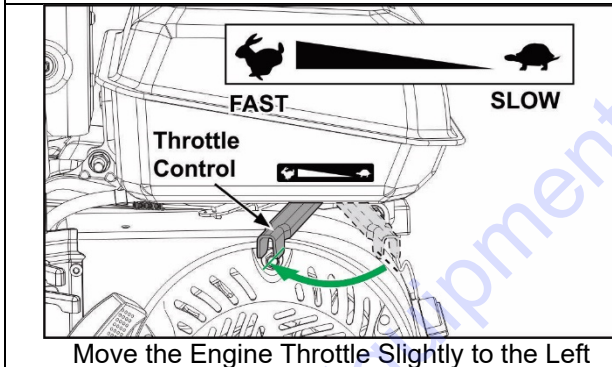
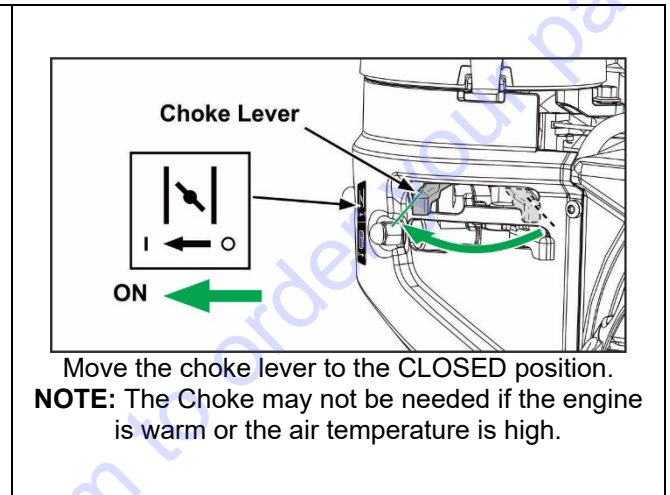
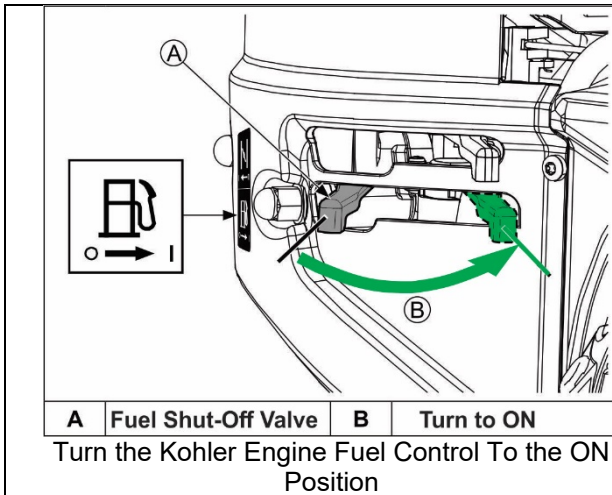

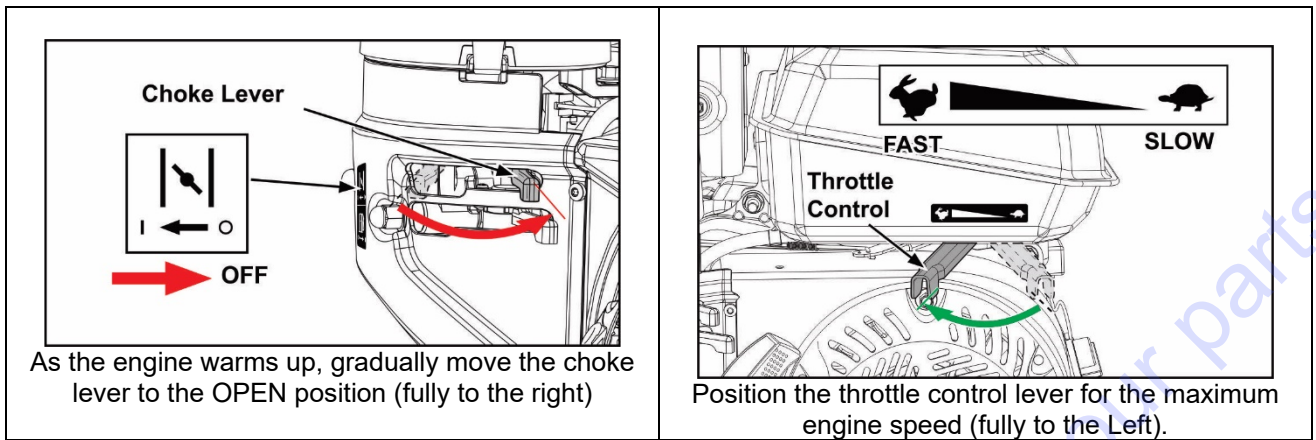

To stop the engine, move the Throttle Control Lever fully to the Slow Position (fully to the right), press the Emergency Stop Switch on the Console, turn the Kohler Engine On/Off switch to the OFF Position, press the Emergency Stop Switch (Down Position), and move the Fuel Control Lever fully to the Right (this will turn off the fuel), and Kohler Engine On/Off switch to the OFF Position. The



Never transport the machine with the Fuel Valve in the ON position. Never Store the machine with the Fuel Valve in the ON position. Never Transport a machine with the blade installed.

C. Water Supply

Pressurized source: Turn the water control to full "ON" when using wet cutting blades. The required flow rate is 4-6 gallons per minute.

D. Operating the Saw

1. For blade installation instructions **see section II. Operation sub heading A. Installing the Blade.** For the engine starting instructions, see the Engine manual and follow the instructions located in section II. **Operation sub heading B. Starting the Engine.**
2. Check the Engine Oil level. See Engine Manual for details.
3. Raise the saw to the full upright position. Do not let the blade come in contact with the ground.
4. Maneuver the saw to the desired starting point.
5. If wet cutting, connect the water supply to the saw.
6. Follow the instructions for starting the engine found in the Engine manual.
7. If wet cutting, turn on the water supply at the source and then open the water valves on the saw. Make sure that there is a minimum of 4-6 gallons per minute of water flow!!
8. Be sure the engine is running at full throttle!!!

9. Slowly lower the blade by rotating the hand wheel clockwise until the desired depth of cut is reached. Use a reasonable rate of feed. Do not force the blade into the cut!!
10. When the end of the cut is reached, slowly raise the blade out of the cut by rotating the Hand Wheel counter-clockwise until the blade is at least one (1) inch above the ground.
11. Only move the saw in reverse with the blade in the raised position.
13. When moving the saw to a new location, be sure the blade is not touching the ground. Always pay close attention to where you are moving and where the blade is at all times.

E. Cutting Technique

Lower the blade into the concrete to the required depth by turning the hand wheel clockwise.

Reduce the forward pressure if the saw begins to stall.

Note: For deeper cuts (4 inches or more), several cuts should be made in incremental steps of 1-1/2 to 2 inches until the desired depth of cut is reached.

Push the saw steadily forward using the front pointer as a guide. Exert enough forward pressure so that the engine begins to labor, but does not slow down. If the saw begins to stall, reduce the forward movement until full rpm is restored to the blade. If the saw stalls, raise the blade out of the cut before restarting. Avoid excessive side pressure or twisting of the blade in the cut.

Additional Guide Lines for Sawing:

- Understand and follow all of the instructions in this owner's manual.
- If wet cutting, turn on the water supply so that there is a minimum of 4-6 gallons per minute of water flow!!
- In critically hard aggregate, more than a single pass may be needed to cut the desired depth.
- If the saw stalls in the cut, immediately stop the forward speed and raise the blade out of the cut. If this is not done the belts can fail or the blade may be damaged.
- Go slowly with a new blade until it opens up, that is, until the diamonds can be seen and felt.

III. MAINTENANCE

A. Engine

Follow the below schedule for engine maintenance. NOTE: Check the Engine manual that came with the engine for any changes to the maintenance schedule. If the charts have any differences, follow the chart in the Honda or

Kohler Engine Manual. Norton does not warranty the engine. If any warranty or service of the engine is required contact Discount-equipment

C13PE with Honda GX390 engines
C14PEK with Kohler CH440 engines

Refer to the engine owner's manual for the engine that is equipped on your machine for owner's manual for complete maintenance, operation, and service information.

C13PE 13HP GX390 Honda Engine Maintenance Schedule

HONDA GX340 · GX390K1/R1/T1/U1/UT1 Maintenance Information

ITEM	REGULAR SERVICE PERIOD (1)					
	Each use	First month or 20 hrs.	Every 3 months or 50 hrs.	Every 6 months or 100 hrs.	Every year or 300 hrs.	Every year or 300 hrs.
Engine oil	A B	●	●	●	●	●
Air cleaner	C D	●	● (2)			● (3)
Sediment cup	E			●		
Spark plug	F					●
Spark arrester (applicable types)	G			● (5)		
Idle speed	H					● (4)
Valve clearance	I J K					● (4)
Combustion chamber	L					● (4)
Fuel tank and filter	M					● (4)
Fuel tube	N					● (4)

(1) For commercial use, log hours of operation to determine proper maintenance intervals.
 (2) Service more frequently when used in dusty areas.
 (3) Replace paper element type only.
 (4) These items should be serviced by your servicing dealer, unless you have the proper tools and are mechanically proficient. Refer to Honda shop manual for servicing procedures.
 (5) In Europe and other countries where the machinery directive 2006/42/EC is enforced, this cleaning should be done by your servicing dealer.

A OIL FILLER CAP/DIPSTICK
UPPER LIMIT
OIL DRAIN BOLT

B SAE Viscosity Grades
30
5W-30 · 10W-30
-20 -10 0 10 20 30 40 °C
-20 -10 0 10 20 30 40 °F
Recommended oil: SAE 10W-30 or SAE 30
API service category: SJ or later
Engine oil capacity: 1.1 ℓ (1.2 US qt)

C <LOW PROFILE TYPE> AIR FILTER ELEMENT
Wash the element in a solution of household detergent and warm water, then rinse thoroughly, or wash in nonflammable or high flash point solvent. Allow the element to dry thoroughly. Soak the air filter element in clean engine oil and squeeze out the excess oil.

D <DUAL ELEMENT TYPE> AIR FILTER ELEMENT
PAPER ELEMENT: Tap the element lightly several times on a hard surface to remove dirt, or blow compressed air (not exceeding 207 kPa, 2.1 kgf/cm², 30 psi) through the element from the inside. Never try to brush off dirt; brushing will force dirt into the paper fibers.
FOAM ELEMENT: SQUEEZE THOROUGHLY

E SPARK PLUG
Loosen the drain screw to drain the carburetor thoroughly before removal.
Standard spark plug:
BP6ES, BPR6ES (NGK)
W20EP-U, W20EPR-U (DENSO)
0.7 - 0.8 mm

G SPARK ARRESTER
Clean the carbon deposits from the spark arrester screen with a wire brush. Be careful not to damage the spark arrester screen.

H THROTTLE STOP SCREW
Specified idle speed: 1,400 ± 150 rpm
On some applications the engine speed is fixed and does not idle.
The standard idle speed may be different depending on the application.
Refer to the equipment manufacturer's instructions for specific idle speed setting.

I TOP HOLE
Set the piston at top dead center of the compression stroke (both valves fully closed).
ALIGN
TRIANGLE MARK

J FEELER GAUGE
Valve clearance: 0.15 mm ± 0.02 mm (IN)
0.20 mm ± 0.02 mm (EX)

K VALVE CLEARANCE
ROCKER ARM
ROCKER ARM PIVOT
ROCKER ARM PIVOT LOCK NUT
VALVE
To increase valve clearance, screw out.
To decrease valve clearance, screw in.

L WIRE BRUSH
Remove any carbon deposits from the combustion chamber using a soft wire brush.

M FUEL TANK AND FILTER
Clean the fuel tank with nonflammable solvent and allow the fuel tank to dry thoroughly. Clean the filter with nonflammable solvent. Inspect the fuel filter to be sure it is undamaged.

N FUEL TUBE
Check the fuel tubes for deterioration, cracks, and other damage. Replace fuel tube(s) if necessary.

Check the engine oil level before each use when the engine is cool and the engine is level. Add oil if the level is low. The oil level should be within the operating range (see the engine owner's manual for details).

Only use a high-detergent, premium quality motor oil certified to meet or exceed U.S. automobile manufacturer's requirements for Service Classification SG, SF/CC, or CD. Motor oils will show the classification on the container. A SAE viscosity of 10W-30 is recommend by Honda for general, all temperature use. Please consult the below chart or contact Discount-equipment for the proper viscosity for your temperature range.

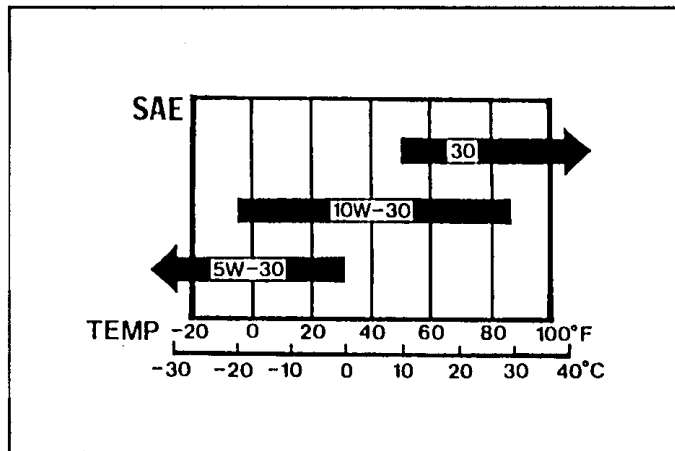

Always refer to the engine manual for more detailed information on checking the oil, changing oil, and oil capacity, air filter changes, and fuel type to use. Use only Honda air filters. Do not clean the air filter with gasoline or other flammable solvents. A fire or explosion could result. To clean, follow the instructions found in the Honda engine manual.

C14PEK 14HP CH440 Kohler Engine Maintenance Schedule

Maintenance Schedule
After first 5 Hours
<ul style="list-style-type: none"> • Change oil.
Every 50 Hours or Annually
<ul style="list-style-type: none"> • Service/replace Quad-Clean™ precleaner.
Every 100 Hours or Annually ¹
<ul style="list-style-type: none"> • Clean low-profile air cleaner element. • Change oil. • Clean cooling areas.
Every 200 Hours
<ul style="list-style-type: none"> • Replace Quad-Clean™ air cleaner element.
Every 300 Hours
<ul style="list-style-type: none"> • Replace low-profile air cleaner element. • Check fuel filters (tank outlet filter and in-line filter) and clean or replace if needed (if equipped).
Every 300 Hours ²
<ul style="list-style-type: none"> • Check and adjust valve clearance when engine is cold.
Every 500 Hours or Annually ¹
<ul style="list-style-type: none"> • Replace spark plug and set gap.
¹ Perform these procedures more frequently under severe, dusty, dirty conditions.
² Have a Kohler authorized dealer perform this service.

Check the engine oil level before each use when the engine is cool and the engine is level. Add oil if the level is low. The oil level should be within the operating range (see the engine owner's manual for details).

Kohler recommends the use of Kohler branded oils for best performance these are available from Discount-equipment. The use of other high quality detergent oils including synthetic that meet the API (American Petroleum Institute) service class of SJ or higher are acceptable. Please select a viscosity based on the environmental air temperature at the time of operation as shown in the table below. For additional information contact Discount-equipment.

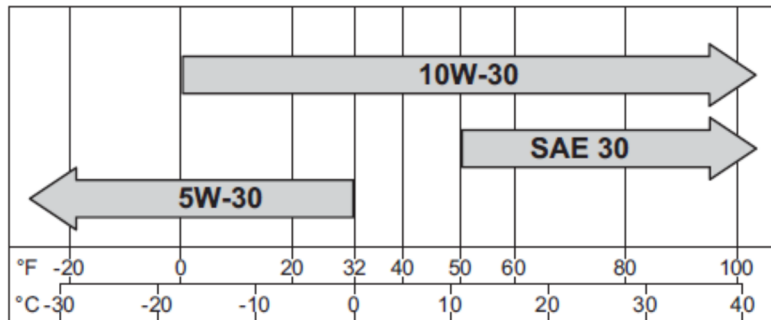

Dry Cutting Engine Maintenance

- When operating the engine in dry cutting or dusty environments the following is required:
- Engine oil changed more often.
- Every 50 hours (or more often if conditions require) clean all of the engine cooling fins.
- Every 25 hours (or more often if conditions require) clean the engine pre-cleaner.
- Every 100 hours (or more often if conditions require) replace the air filter. If the engine is equipped with a reusable air cleaner, clean and re-oil it.
- Check and clean the air filter after each use. Replace as needed.

C. Bearings

Re lubrication type bearings must be re-lubricated weekly to assure long life. The grease used should conform to the NLGI grade two and be free of any chemical impurities such as free acid or free alkali, dust, rust, metal particles or abrasives.

For best results, bearings should be re-lubricated while in operation. **Note: Due caution for personal safety must be observed when servicing rotating equipment.** The grease should be pumped in slowly until a slight bead forms around the seals. This bead, in addition to acting as an indicator of adequate re-lubrication, provides additional protection against the entry of foreign matter. If necessary to re-lubricate while the bearing is idle refer to re-lubrication table for maximum grease capacity for the various size bearings.

Shaft Size	Maximum Grease Capacity of Bearing Chamber in Ounces
1/2" to 3/4"	1/8
7/8" to 1-3/16"	3/8
1-1/4" to 1-1/2"	5/8



Improper Maintenance of Bearings Is Not Covered by Any Warranty. Over Lubrication Will Damage a Bearing. Grease Protruding from the Sides of the Bearing Is a Sign of Over Lubrication. Not Lubricating Bearings Will Damage the Bearing Unit. Damage Caused By Over or Under Lubricating Bearings Is Not Covered By Any Warranty.

D. V-Belts

Warning: Never make adjustments to belts or pulleys while engine is running!

The best tension for a belt drive is the lowest tension at which the belts will not slip under full load.

Belt Tension C13PE and C14PEK:

The C13PE and C14PEK uses a simple single point tensioning system for the belt tensioning. The Belt Tensioning Assembly can be found behind the engine and is located near the Operator's Left Side Rear Engine Mounting Bolt. The Belt Tensioning Device is designed to pull or push the engine from the center which helps to reduce the Engine from twisting during the Belt Tensioning process. This new system is designed to be simple to install and to maintain with the tools equipped with the machine.



Insure that the Engine ON/OFF Switch is in the OFF position and that the Spark Plug is disconnected before making any adjustment to the Belt tension.

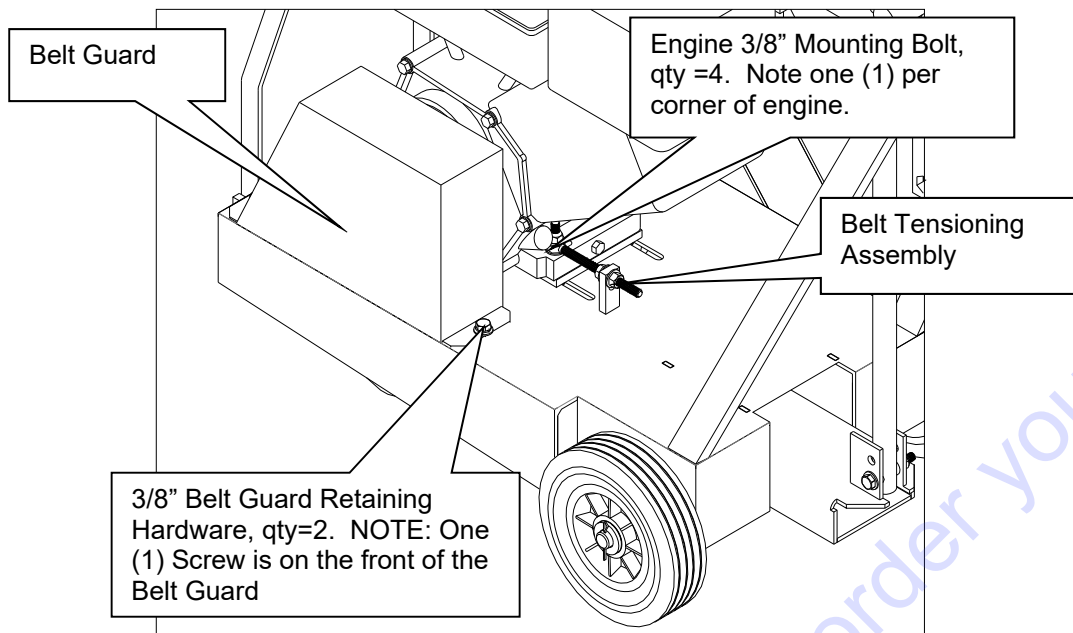

Figure: C13PE and C14PEK Belt Tensioning System

1. Review the locations of the C13PE and C14PEK Belt Tensioning system before proceeding. (See **Figure: C13PE and C14PEK Belt Tensioning System** on the previous page).
2. Remove the Belt Guard by loosening and removing the two (2) 3/8" Belt Guard Retaining Hardware sets.
3. Check belt tension by pushing up or down at the center top span of the belt. The belt should move around 3/8" to 1/2" up and down. If adjustment is needed go to step 4. If no adjustment is required, replace belt guard and tighten all of the 3/8" Belt Guard Retaining Hardware.
4. Slightly loosen the four (4) 3/8" Engine Mounting Bolts. NOTE: The four 3/8" Engine Mounting Bolts will need to remain snug during the belt tensioning process. Not keeping the 3/8" Engine Mounting Bolts snug may allow the engine to twist in the mounting slots which may result in the pulleys becoming missed aligned.
5. Loosen the two (2) 3/8" Jam Nuts on the C13PE and C14PEK Belt Tensioning Assembly (See **Figure: C13PE and C14PEK Belt Tensioning Assembly** below).

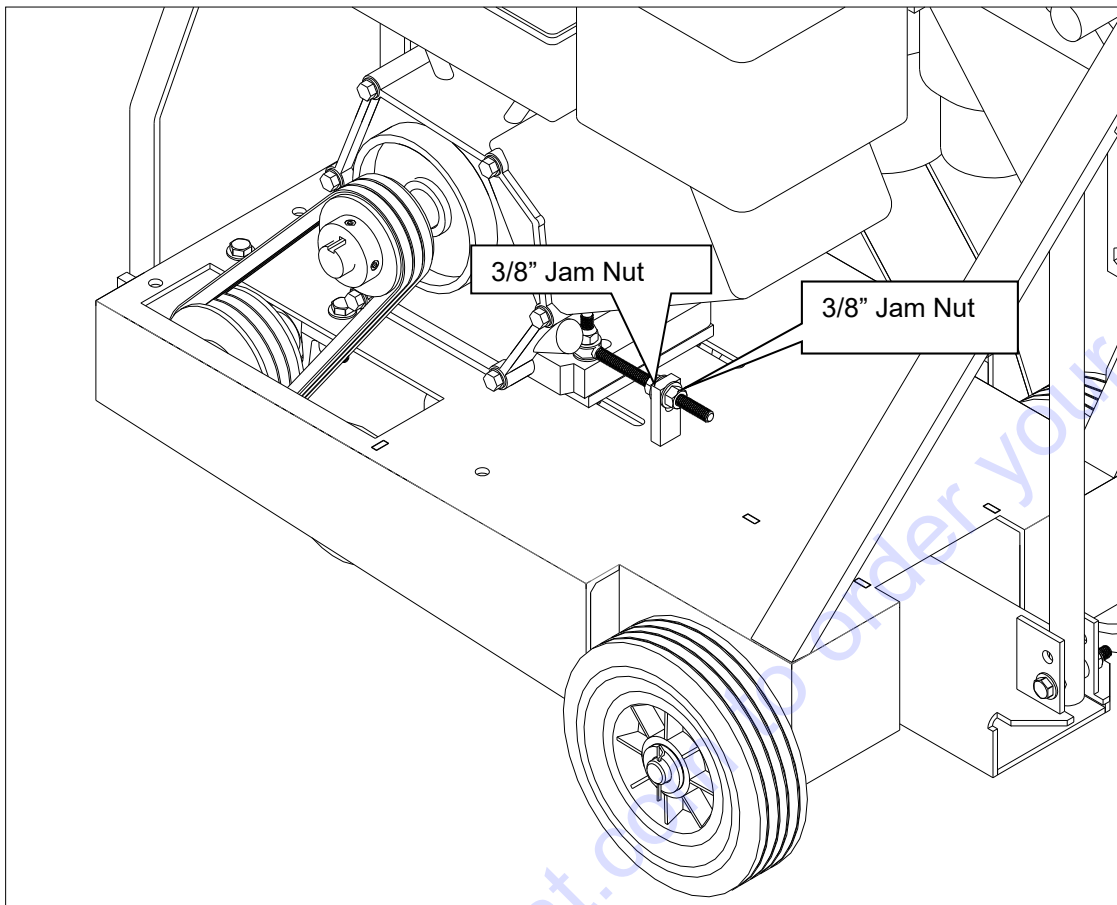

Figure: C13PE and C14PEK Belt Tensioning Assembly

6. To apply tension to the Belts, tighten (turn clockwise) the rear 3/8" Jam Nut until the required Belt Tension is achieved. To loosen the Belts, turn the front 3/8" Jam Nut counter clockwise until the required Belt Tension is achieved. (See **Figure: C13PE and C14PEK Belt Tensioning Jam Nut Directions**). NOTE: Do not over tighten the belts as too tight of belts can break Engine Output Shafts, Blade Shafts, Belts, and cause premature Bearing Failures. Failures due to too tight of Belts are not covered by any warranty. Too loose of Belts will cause the Belts to slip under load, and may cause burning of the Belts and is not covered under any warranty.

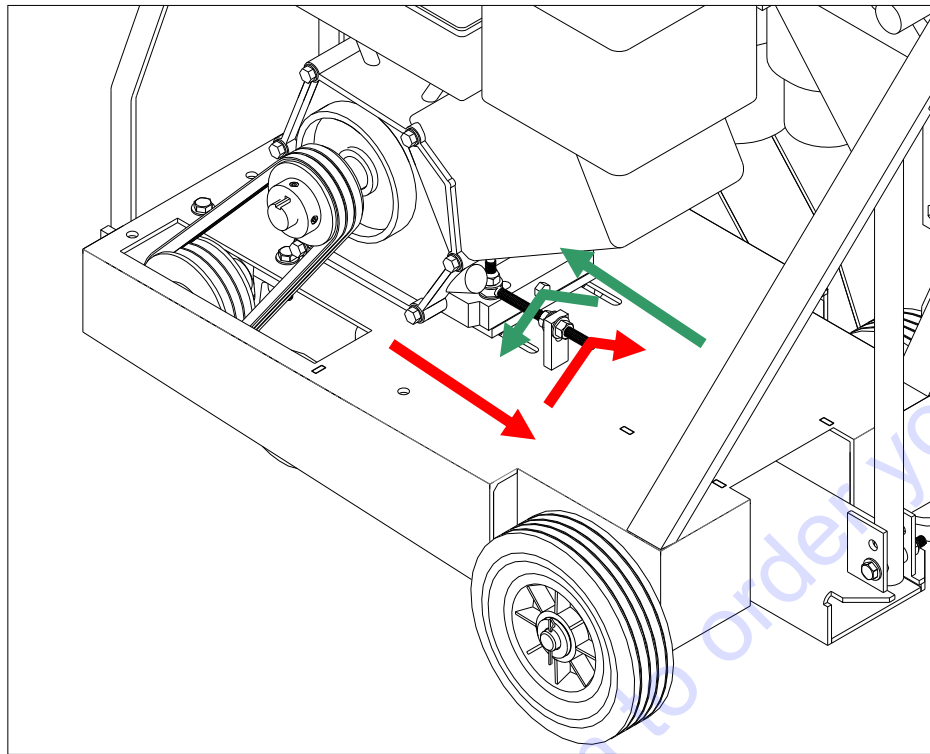

Figure: C13PE and C14PEK Belt Tensioning Jam Nut Directions

7. Tighten the four (4) 3/8" Engine Mounting Bolts.
8. Replace the Belt Guard and replace and tighten the 3/8" Belt Guard Retaining Hardware.
9. Run the machine for around 15 minutes and recheck the belt tension. If the Belts slip under load increase the belt tension.

Remember, too much tension shortens belt and bearing life!

Check the belt tension frequently during the first day of operation. Check the belt tension periodically thereafter and make any necessary adjustments.

Belt Alignment:

1. Review the locations of the C13PE and C14PEK Belt Tensioning system before proceeding. (See **Figure: C131PE and C14PEK Belt Tensioning System** on page 15).
2. Remove the Belt Guard by loosening and removing the three 3/8 Belt Guard Retaining Bolts.
3. Line up a straight edge along the outside face of both pulleys. (See **Figure: Pulley Alignment** to the right.)
4. Misalignment will show up as a gap between the pulley face and the straight edge.
5. To correct the misalignment, move one pulley in or out as required.

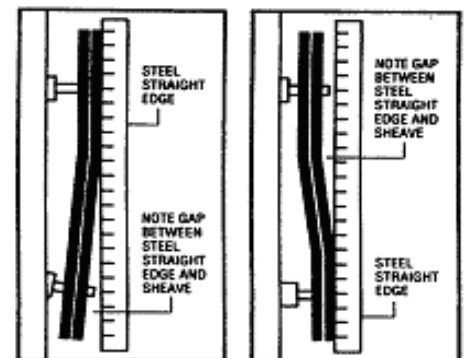

Figure: Pulley Alignment

Main Causes of Belt Failures:

Premature Belt failure can be attributed to the following issues: Tension (too much or too little), Pulley Misalignment, Damaged Pulleys, Improper Handling or Storage, Incorrect Blade Specification for Material Being Cut, and Cutting Too Deep.

Symptom	Possible Cause	Corrective Action
Belt Breakage	Too Much Tension	Re-tension Belts
	Excessive Shock Load	Reduce Load/ Check Blade Specification
	Pulley Out Of Round	Replace Pulley
Burning of Belt	Too Little Belt Tension	Increase Belt Tension
	Excessive Load (Cutting Full Depth)	For Best Performance Only Cut only 1-1/2" to 2" Per Pass
	Containments On Belts	Replace Belts and Find Source Of Containments
	Incorrect Blade Specification	Replace Blade With One Designed For Material Being Cut
Belt Tearing/Ripping	Pulley Misalignment	Align Pulleys
Belt Rolling Off Pulley	Pulley Misalignment	Align Pulleys
Belt Cracking	Extremely Low Temperature at Startup	Warm Machine Before Use
	Exposure To Chemicals or Lubricates	Locate Source of Containments and Replace Belts.



Belts are a normal wear item and are not covered under warranty.

E. Depth Control

The depth control (raising screw) consists of a threaded rod, which feeds into a steel nut. In order to keep the two parts working smoothly it is necessary to keep the rod free from dirt and sludge as much as possible. Cleaning the threaded rod with a rag after each use will prevent sludge from collecting in the tube assembly and protect the threads. It is a good practice to keep the raising screw threads lubricated, as the slurry generated during cutting will cause premature thread wear. Two (2) revolutions of the Raise Lower Handle will change the depth of cut by 1/4". The bearing used to support the raising screw should be checked after each use to make sure it is turning freely and lubricated. If the bearing requires re lubrication lithium base grease is recommended.



STOP turning the Depth Control Hand Wheel when resistance is felt. Resistance is a sign that either the full depth or fully raised positions are reached. Continuing to turn the Hand Wheel will result in the breakage of either the flange bearing or stripping of the raise screw which is not considered warranty.

F. Inspections and Cleaning

For long life and better machine performance follow the inspection and cleaning schedule below.

Regular Service Period Preformed
At Every Indicated Period →

		After First Hour of Work	Beginning Of Day	During Blade Change	End Of Day	Once A Week	After Failure	After Damage
Whole Machine	Inspect For Damaged or Missing Components	X	X			X	X	X
	Clean		X			X		
Blade Collars	Clean			X				
Belt Tension	Check	X				X	X	X
Water Hose, Water Fittings, and Nozzles	Clean		X			X		
	Inspect		X			X		X
Depth Screw	Grease					X		
Engine	Clean					X		
Reachable Hardware	Tighten					X		
Bearings (Blade Shaft and Depth Control)	Grease*					X		
Wheels	Inspect	X	X			X	X	X

* = See Bearing Maintenance of This Manual Before Greasing



Replace any damaged or missing components before using machine.

F. Wiring Diagram

C13PE 13HP Honda

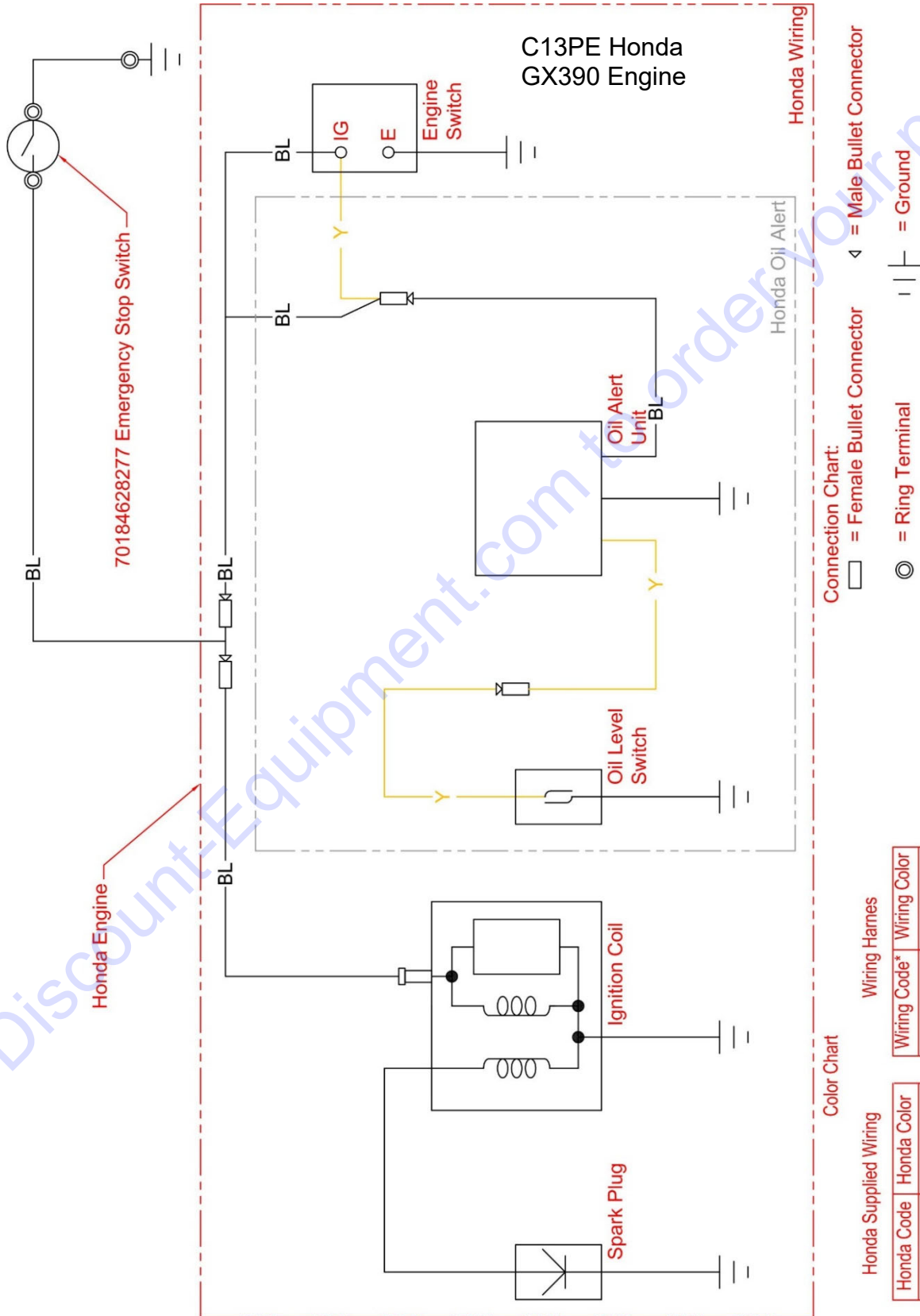

Connection Chart:
 ◻ = Female Bullet Connector ◁ = Male Bullet Connector
 ⊙ = Ring Terminal | | | = Ground

Color Chart

Honda Supplied Wiring		Wiring Harness	
Honda Code	Honda Color	Wiring Code*	Wiring Color
BL	Black	BL	Black
Y	Yellow		

F. Wiring Diagram

C14PEK 14HP Kohler

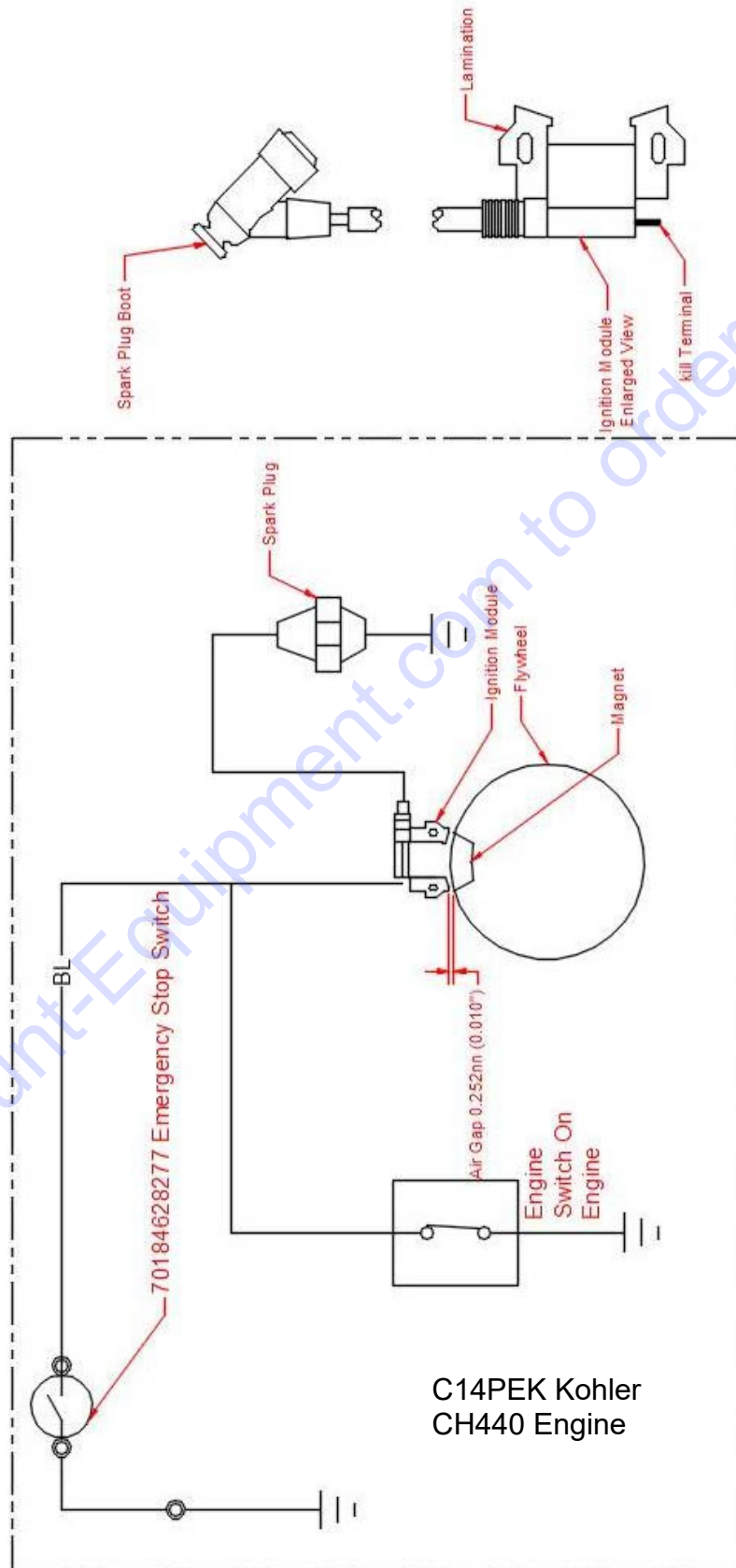

IV. PARTS LIST SECTION

A. Ordering Information

1. List model number and serial number of machine.
2. List UPC (Universal Product Code) number and description. Do not list the item number.
3. Wherever alternate parts are shown due to product improvement, inspect the part you have and provide additional description as necessary.
4. Specify mode of shipping desired, such as, parcel post, truck, UPS, FedEx, best way, etc.

Common Replacement Parts

UPC	Part Number	Description
70184647698	247304	3VX300 Set of three (3)
70184627158	105376	Nut 1-14 UNF Hex Jam Left Hand Thread
70184647703	247204	Tight Collar C13PE AND C14PEK
70184647702	247202	Loose Collar W/Pin C13PE AND C14PEK
70184673905	227175	Bearing Blade Shaft (1) (No Hardware)
70184674102	227162	Wheel 4X1-1/2X3/4 Front (1)
70184674103	227148	Wheel 8X2-1/2X3/4 Rear
70184628074	238213	Wrench Open End

NOTE: All Parts Are Sold as Individual (each) Unless Noted Otherwise

NOTE: All Parts Are Sold as Individual (each) Unless Noted Otherwise by A (x) In The Description Where x= The Quantity Included. For example, 70184647598 BELT 3VX300 (3) three (3) Belts are included.

Kitted items are shown in a phantom lined box within the parts drawing.

Blades Use Only Norton Diamond Blades. Contact Discount-equipment for the best blade for the application.

All parts are designated as either Service Parts (S) or Wear Parts (W) in the Type column in the parts listing. Wear parts are worn out through normal use of the machine. The wear period depends on the intensity of use of the machine, handling, and maintenance of the machine. Wear parts must be serviced and eventually changed following the indications of the manufacturer. Any wear due to normal use of the machine will not be considered as a case of warranty for items designated as Wear Parts (W). For best performance and life Genuine Norton Clipper replacement parts should always be used. Changes to part specifications, are subject to change without notice.

Depth Control and Depth Lock Group

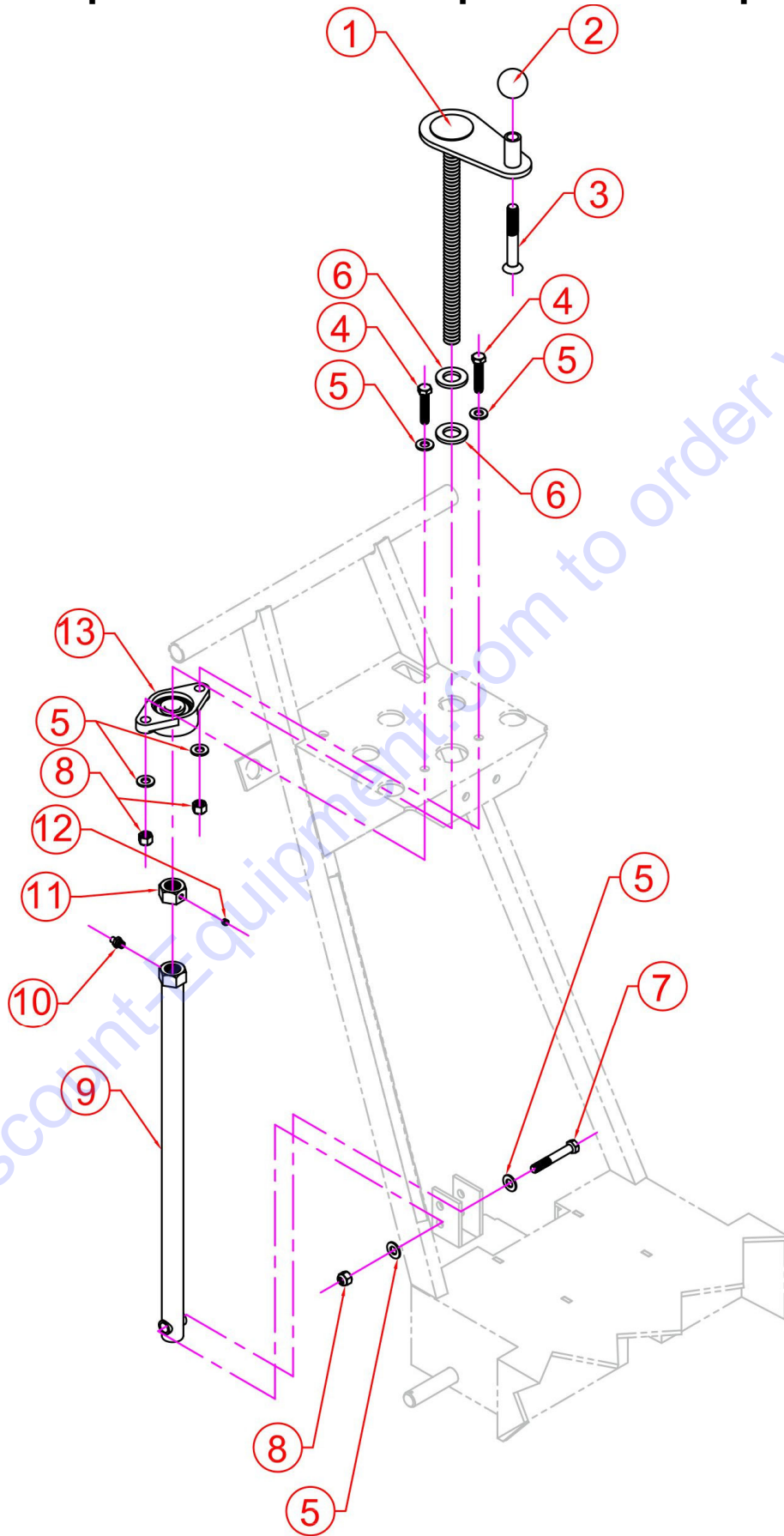

Depth Control and Depth Lock Group

POS	UPC No	Part No	Description	QTY	Type	NOTES
1	70184647692	247801	Hand Wheel Weldment C13PE/C14PEK	1	S	Hand Wheel Body and Raise Screw
2	70184628279	238202	Ball Knob	1	S	
3	70184647693	247805	Screw 1/2"-13 UNC x 3 Socket Head	1	S	Sold As Each
4	70184649906	8041056	Screw 3/8"-16 UNC x 2-1/2 Hex Head Cap	2	S	Sold As Each
5	70184650123	8172009	Washer 3/8" SAE	6	S	Sold As Each
6	70184650129	8172015	Washer 3/4 SAE	2	S	Sold As Each
7	70184649906	8041056	Screw 3/8"-16 UNC x 2-1/2 Hex Head Cap	1	S	Sold As Each
8	70184650373	8160003	Nut 3/8"-16 UNC Nylock	3	S	Sold As Each
9	70184628181	238164	Depth Screw Tube	1	S	Set Grease Zerk Not Included
10	70184628182	238234	Grease Fitting 1/8" NPT x 11/16"	1	S	1/8" National Pipe Thread Male x 11/16" Long
11	70184628265	238163	Nut 3/4"-10 Hex Head for Depth Screw	2	S	Sold As Each
12	70184682129	407035	Screw 1/4"-20 x 1/2" Set Cup Point	1	S	Sold As Each
13	70184650406	210071	Bearing Flange 3/4" Bore	1	W	Includes Set Screw

Type: S = Service Part, W = Wear Part, All Parts Are Sold As Individual (each) Unless Noted Otherwise

Blade Guard and Water Control Group

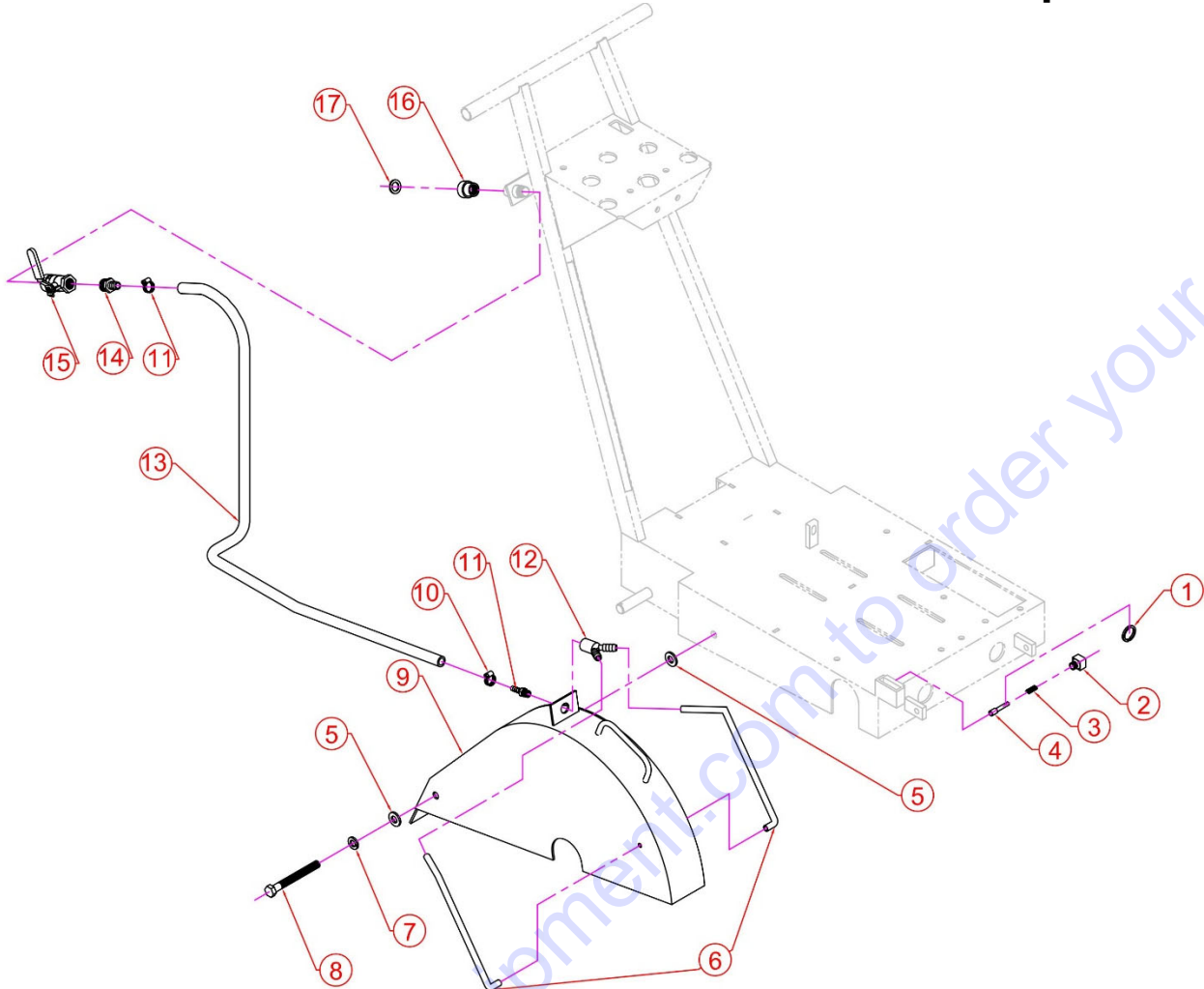

POS	UPC No	Part No	Description	QTY	Type	NOTES
1	70184628501	238223	Ring Guard Lock	1	S	
2	70184628498	238225	Guard Lock	1	S	
3	70184628499	238224	Spring Guard Lock	1	W	
4	70184628500	238222	Pin Guard Lock	1	S	
5	70184650124	8172011	Washer 1/2" SAE	2	S	Sold as Each
6	70184681299	082998	Nozzel Water (2)	1	W	Set of two (2) Nozzles 5/16" ID x 7/16" OD x 10" Long
7	70184650154	8177014	Washer 1/2" Spring Lock	1	S	Sold as Each
8	70184649929	8041107	Screw 1/2"-13 x 4-1/2" Hex Head Cap	1	S	Sold as Each
9	70184647694	247106	Blade Guard Weldment C13PE/C14PEK	1	S	Blade Guard Weldment Only
10	70184659232	N1C0113	Clamp Hose #10 1/2" Wide x 1/2" TO 29/32"	2	S	
11	70184650465	9600014	Fit Barb Hose 1/4MPT x 1/2"	1	S	
12	00310004233	072286	Fit Hose "Y"	1	S	
13	70184683507	0042521	Tube 1/2ID X 3/4OD 48" Long	1	S	Use 36
14	70184626501	9602012	Fit Barb Hose 1/2" MNPT x 1/2" Male Barb	1	S	1/2" Male National Pipe Thread Taper x 1/2" Male Barb Fitting
15	70184659097	N1C0021	Valve Water 1/2"	1	S	
16	70184659115	N1D0082	Swivel Hose 3/4" Garden Hose Female x 1/2" FNPT	1	S	1/2" Female National Pipe Thread Taper x 3/4" Garden Hose Swivel
17	70184650620	101868	Washer Hose 1.00OD x .625	1	W	

Type: S = Service Part, W = Wear Part, All Parts Are Sold As Individual (each) Unless Noted Otherwise

Engine Group

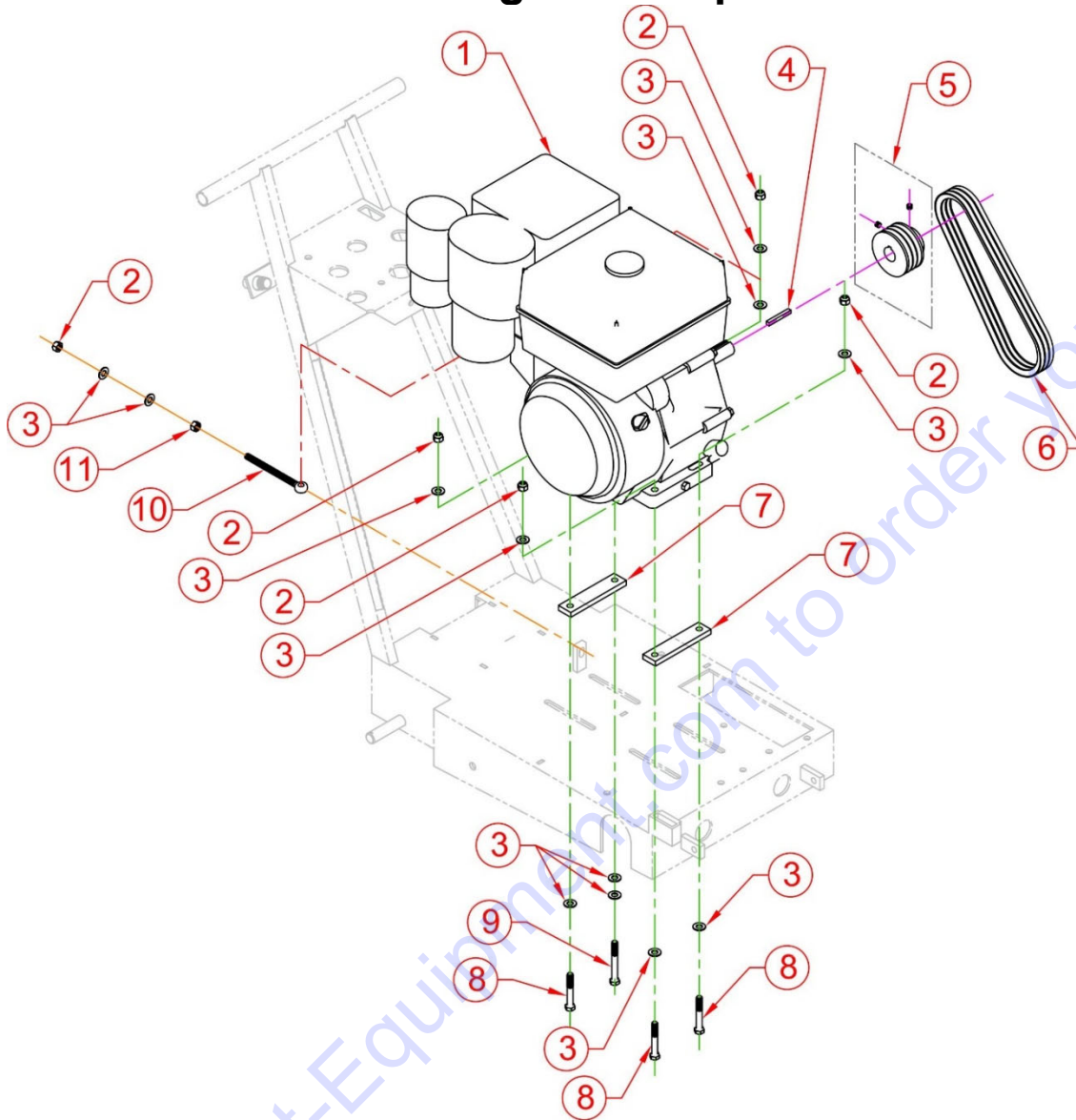

POS	UPC No	Part No	Description	QTY	Type	NOTES
1	70184671620	123327	Engine 13HP Honda Manual Start GX390UT2QXC9	1	S	Engine Only. C13PE Model Honda Specification GX390UT2QXC9
			Engine 14HP Honda Manual Start PA-CH440-1349	1	S	Engine Only. C14PEK Model Honda Specification PA-CH440-1349
2	70184650373	8160003	Nut 3/8"-16 UNC Nylock	5	S	
3	70184650123	8172009	Washer 3/8 SAE	12	S	Sold Individually (1)
4	70184649705	9201117	Key 1/4" x 1-1/2"	1	S	
5	70184647695	247303	Pulley 3.15OD x 1" B 3G 3V	1	S	Includes Set Screws 70184678503 QTY =2
	70184678503	231239	Screw 5/16"-18 UNC x 1/4" Set Cup Point	2	S	Sold Individually (1)
-NA-	70184647698	247304	Belt 3VX300 (3)	1	W	Set of Three (3) Matched 3VX300 Belts
7	70184647696	247305	Spacer Engine C13PE/C14PEK	2	S	Sold Individually (1)
8	70184649906	8041056	Screw 3/8"-16 x 2-1/2" Hex Head Cap	3	S	
9	70184649907	8041058	Screw 3/8"-16 x 3" Hex Head Cap	1	S	
10	70184647699	247306	Eye Bolt 3/8"-16 UNC x 5"	1	S	
11	70184650349	8142003	Nut 3/8"-16 UNC Hex Jam	1	S	

Type: S = Service Part, W = Wear Part, All Parts Are Sold As Individual (each) Unless Noted Otherwise

Blade Shaft Group

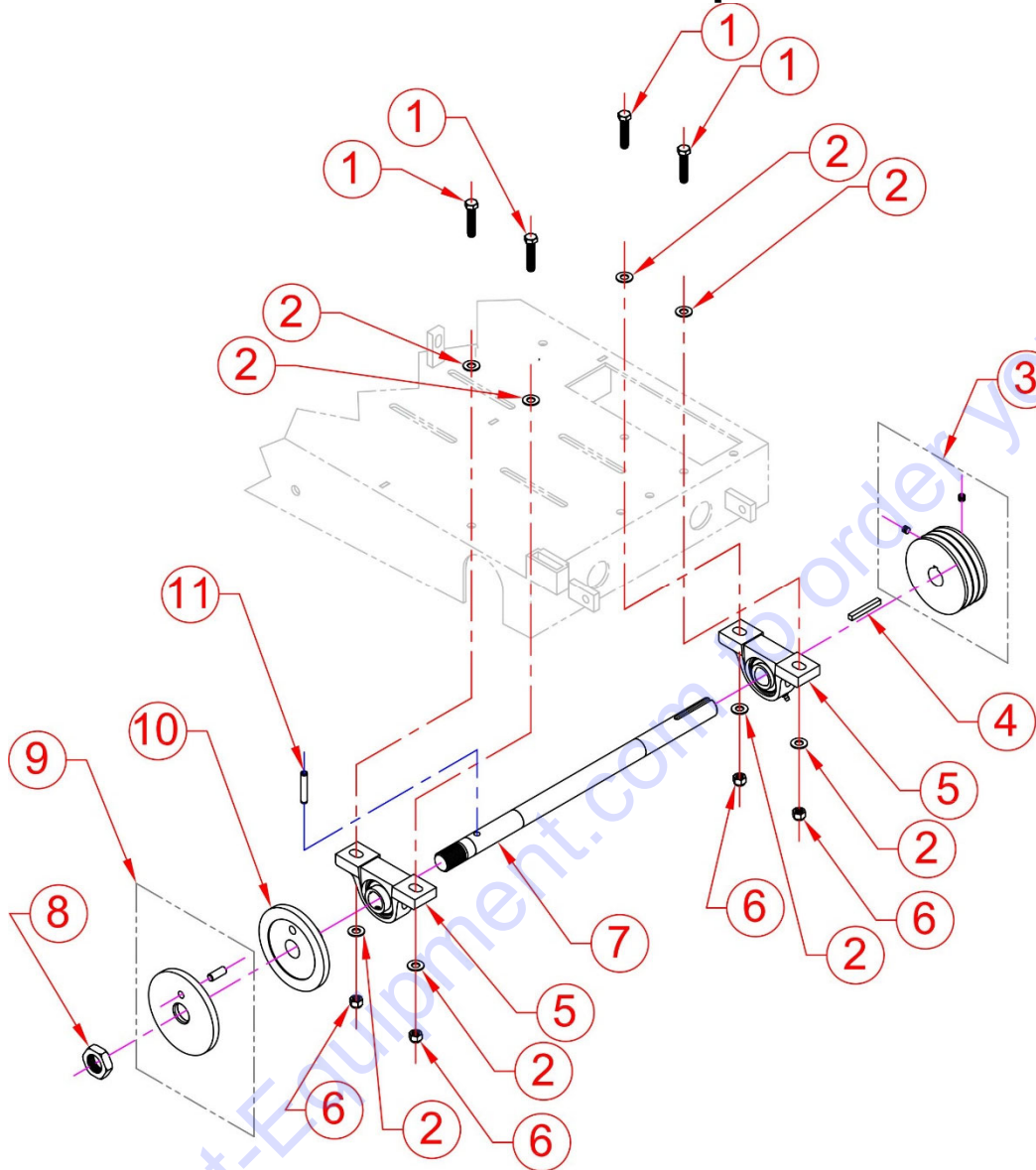

POS	UPC No	Part No	Description	QTY	Type	NOTES
1	70184649903	8041053	Screw 3/8" -16 x 1-3/4" Hex Head Cap	4	S	
2	70184650123	8172009	Washer 3/8" SAE	8	S	
3	70184647700	247302	Pulley 4.12OD x 1" B 3G 3V	1	S	Includes Set Screws 70184678503 QTY =2
	70184678503	231239	Screw 5/16"-18 UNC x 1/4" Set Cup Point	2	S	Sold Individually (1)
4	70184649705	9201117	Key 1/4" x1-1/2"	1	S	
5	70184673905	227175	Bearing Pillow Bock 1"	2	W	Sold Individually (1) Includes Set Screw and Grease Zerk. Does NOT Include:Mounting Hardware
6	70184650373	8160003	Nut 3/8"-16 UNC Nylock	4	S	
7	70184647701	247201	Blade Shaft C13PE AND C14PEK	1	S	Blade Shaft Only
8	70184627158	105376	Nut 1-14 UNF Hex Jam Left Hand Thread	1	W	
9	70184647702	247202	Loose Collar W/Pin C13PE AND C14PEK	1	W	Includes Pin 3/8" x 1" Dowel 70184650531
	70184650531	9196110	Pin 3/8 x 1 Dowel	1	W	
10	70184647703	247204	Tight Collar C13PE/C14PEK	1	W	
11	70184647704	9195250	Pin 5/16" x 1-3/4" Roll	1	W	

Type: S = Service Part, W = Wear Part, All Parts Are Sold As Individual (each) Unless Noted Otherwise

Raise Axle Group

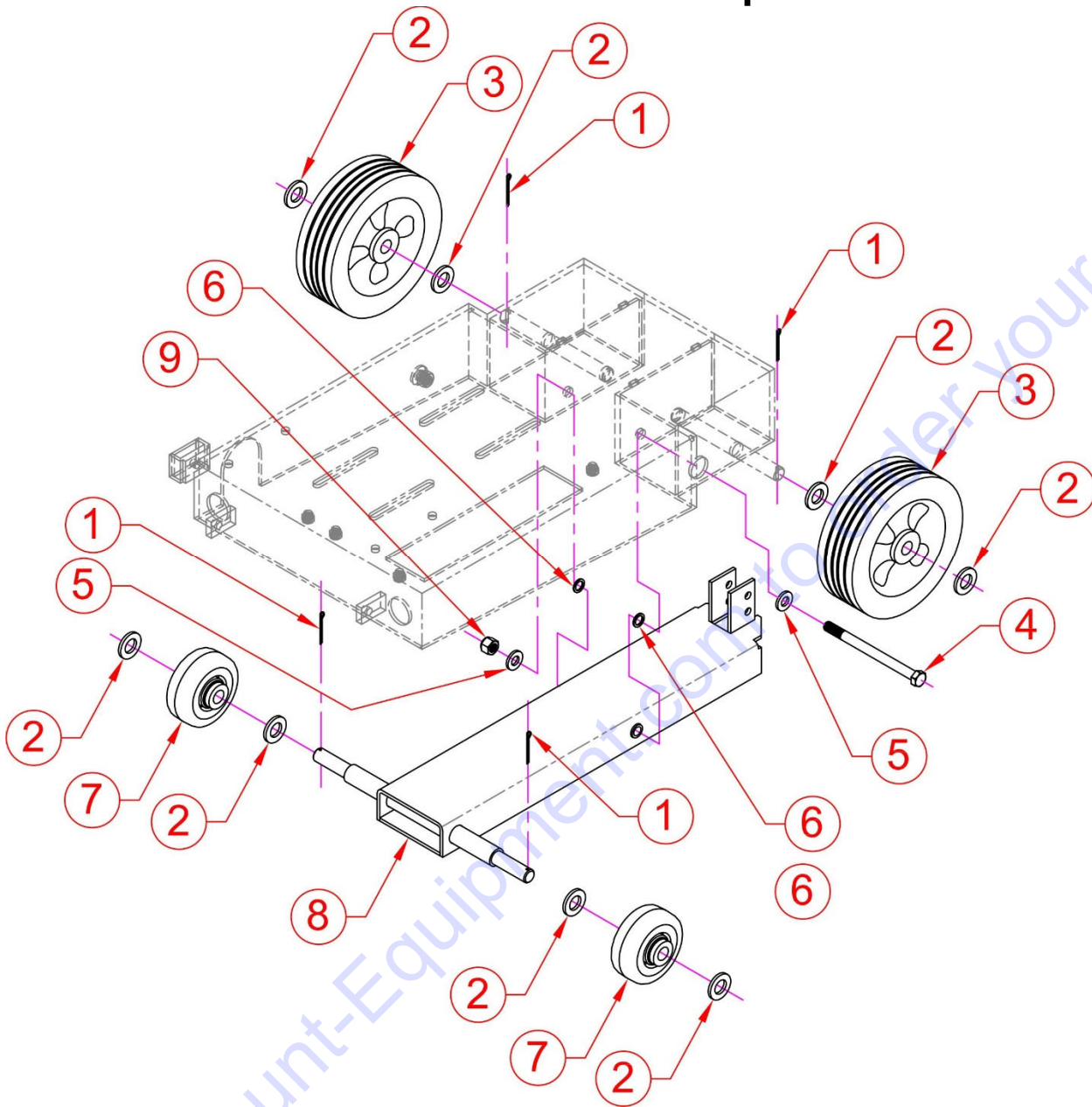

Item	UPC No	Part No	Description	QTY	Type	NOTES
1	70184674553	227146	Pin Cotter 1/8" x 1-1/2"	4	W	
2	70184650129	8172015	Washer 3/4" SAE	8	S	
3	70184674103	227148	Wheel 8" x 2"-1/2" x 3/4" Rear	2	W	Sold Individually (1)
4	70184647705	247409	Screw 1/2"-13 UNC x 6-1/2" Hex Head Cap	1	S	
5	70184650123	8172009	Washer 3/8" SAE	2	S	
6	70184647706	247406	Washer 1/2" Nylon Flat	2	W	
7	70184674102	227162	Wheel 4" x 1-1/2" x 3/4" Front (1)	2	W	Sold Individually (1)
8	70184647707	247401	Raise Axle Weldment C13PE AND C14PEK	1	S	Raise Axle Only
9	70184650373	8160003	Nut 3/8"-16 UNC Nylock	1	S	

Type: S = Service Part, W = Wear Part, All Parts Are Sold As Individual (each) Unless Noted Otherwise

Main Frame and Belt Guard Group

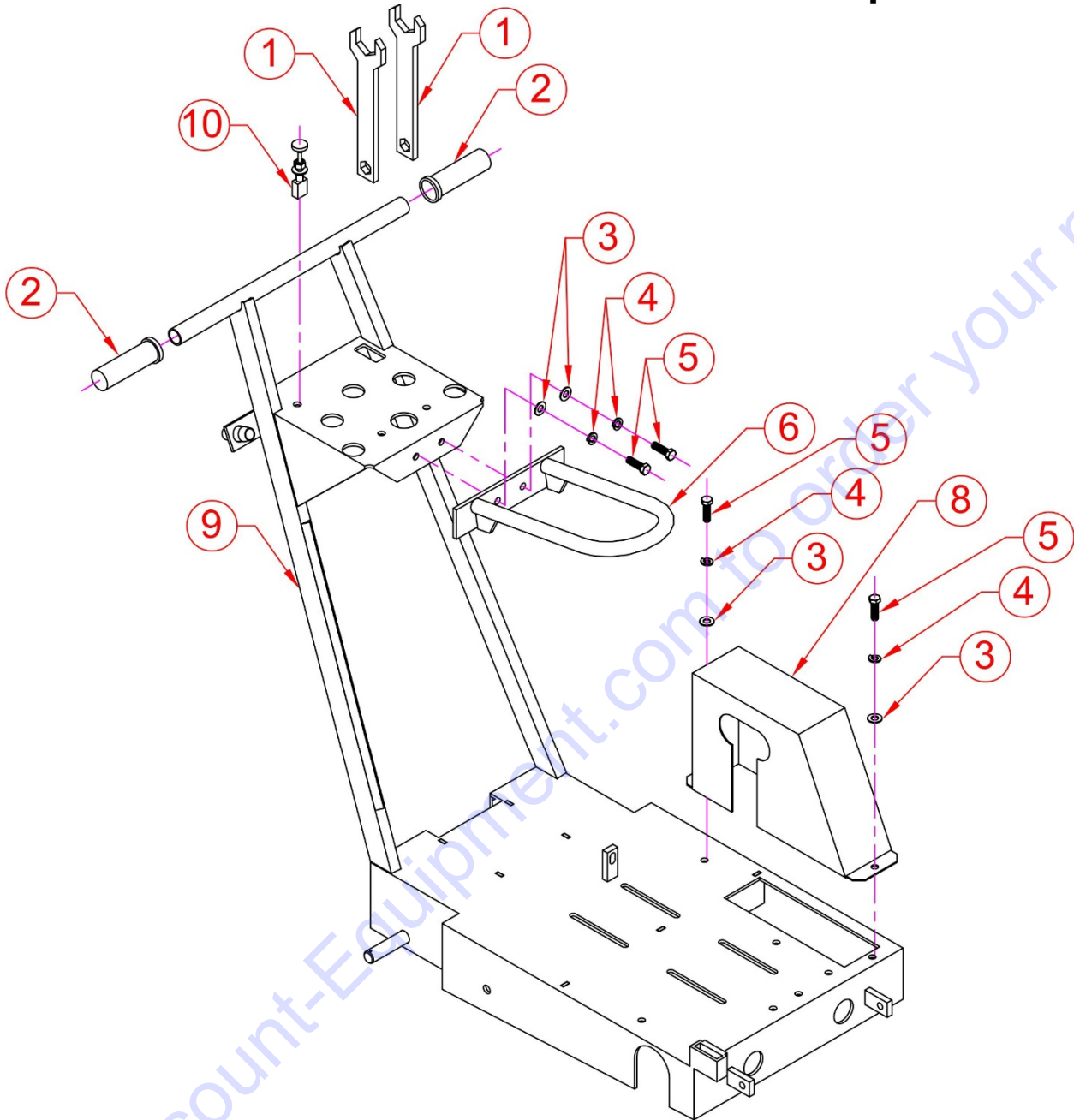

POS	UPC No	Part No	Description	QTY	Type	NOTES
1	70184628074	238213	Wrench Open End 1-1/2"	2	W	
2	70184674393	227101	Hand Grip	2	W	Sold Individually (1)
3	70184650123	8172009	Washer 3/8" SAE	4	S	Sold Individually (1)
4	70184650149	8177012	Washer 3/8" Spring Lock	4	S	Sold Individually (1)
5	70184649901	8041051	Screw 3/8"-16 X 1-1/4" Hex Head Cap	4	S	Sold Individually (1)
6	70184647708	247016	Lifting Bale Weldment C13PE/14PEK	1	S	
8	70184647709	247601	Belt Guard Weldment C13PE/C14PEK	1	S	
9	70184647710	247001	Main Frame Weldment C13PE/C14PEK	1	S	Main Frame Weldment Only
10	70184602385	247307	Emergency Kill Switch Honda Normally Open	1	W	Normally Open (NO)

Type: S = Service Part, W = Wear Part, All Parts Are Sold As Individual (each) Unless Noted Otherwise

Front Pointer Group

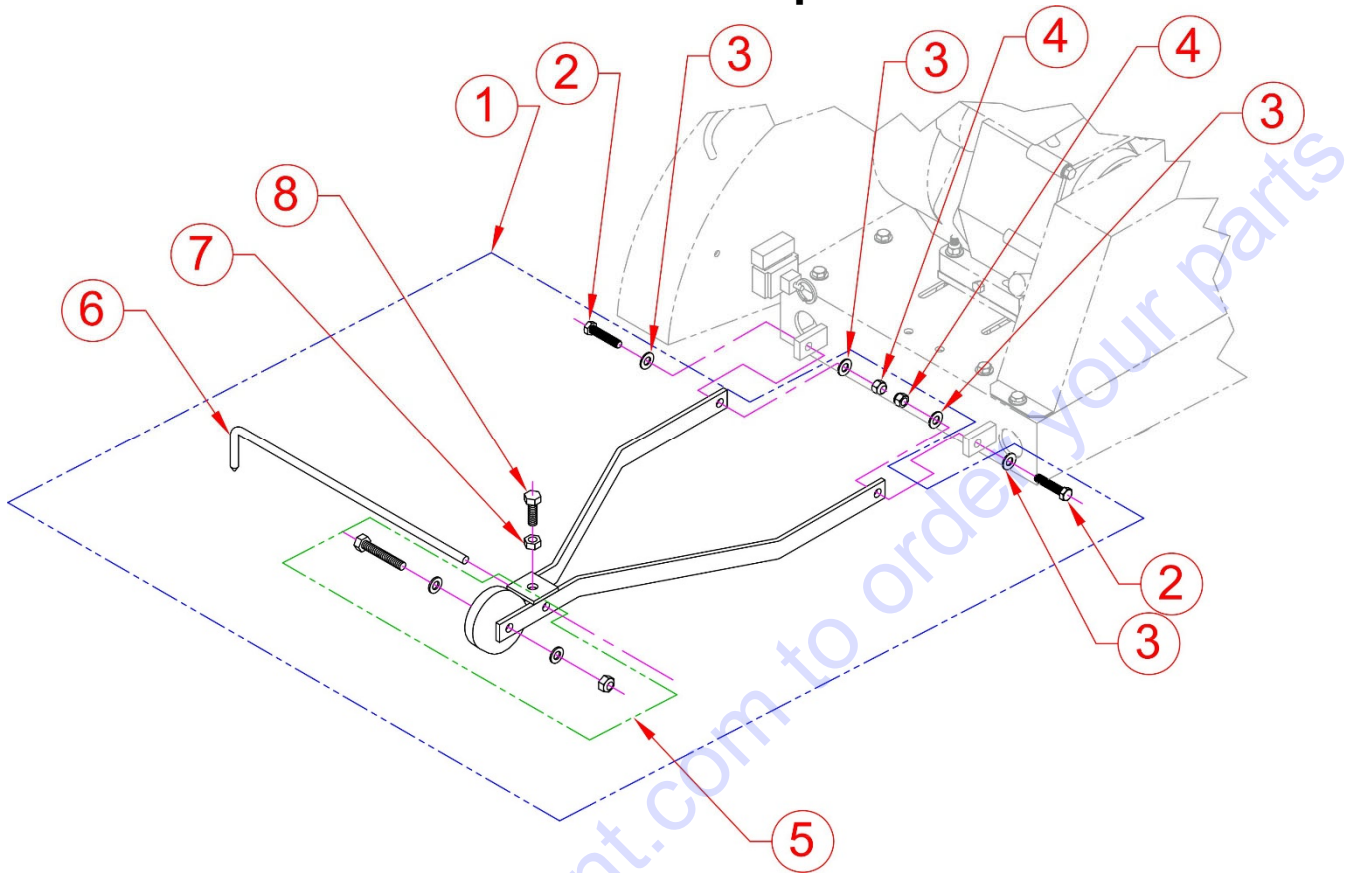

POS	UPC No	Part No	Description	QTY	Type	NOTES
1	00310024051	232127	Pointer Assembly	1	S	Includes: Front Pointer Rod, Pointer Frame, Wheel, and Hardware. NOTE: Hardware in 00310024051 is metric but will function without any issues. Pointer Frame Weldment is only available as part of 00310024051
2	70184649903	8041053	Screw 3/8"-16 X 1-3/4" Hex Head Cap	2	S	
3	70184650123	8172009	Washer 3/8" SAE	4	S	
4	70184650373	8160003	Nut 3/8-16 Hex Lock	2	S	
5	00310004622	232126	Wheel Pointer W/Hardware	1	S	
6	00310004244	232125	Pointer Rod	1	S	Pointer Rod Only
7	70184627482	237242	Screw M10 X 50 1.5 DIN933 Hex Head Cap Full Thread	1	S	
8	70184681615	27006	Nut M10 1.5 DIN934 Hex Jam	1	S	

Type: S = Service Part, W = Wear Part, All Parts Are Sold As Individual (each) Unless Noted Otherwise

Optional Water Tank Group C13PE/C14PEK

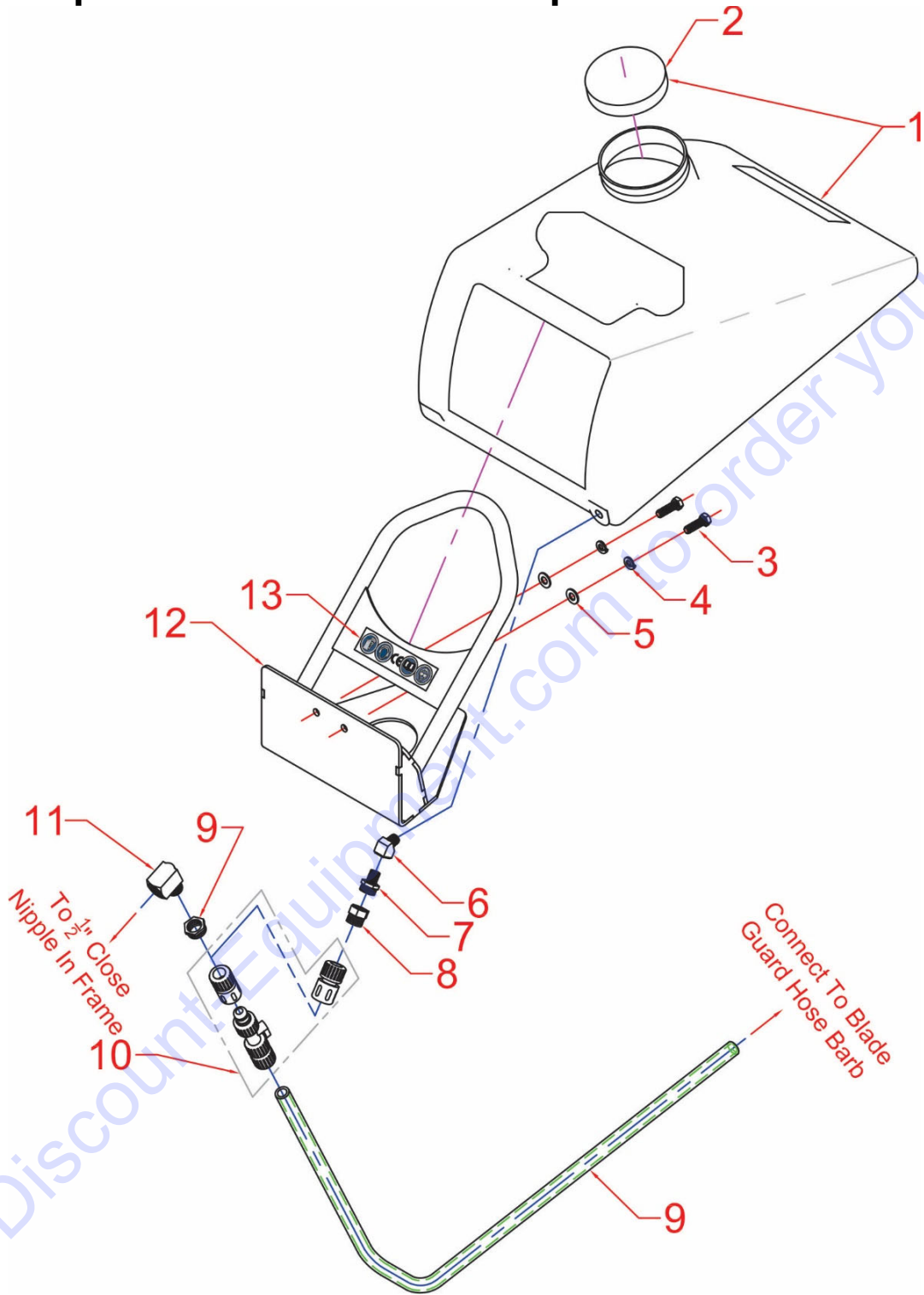

Optional Water Tank Group C13PE/C14PEK

POS	UPC No	Part No	Description	QTY	Type	NOTES
	70184631499	247120	WATER Tank Assembly C13PE	1	S	Optional Water Tank Kit Includes: Water Tank, Cap (Plug), All Fittings shown below, Hose to Blade Guard, and Mounting Hardware
1	00510069471	50941	WATER Tank Complete	1	S	Includes: Water Tank and Stopper (Cap)
2	00310006560	82794	Cap for Water Tank (Stopper)	1	S	
3	70184649901	8041051	SCR 3/8-16 X 1-1/4 HEXHDC	2	S	Sold as EACH (1)
4	70184650149	8177012	WASHER 3/8 SPRING LOCK ZN	2	S	Sold as EACH (1)
5	70184650123	8172009	WASHER 3/8 SAE ZN PLT	2	S	Sold as EACH (1)
6	70184602424	70184602424	Elbow 1/4MPT x 1/4FPT x 45 Brass	1	S	Sold as EACH (1)
7	70184682454	083218	Reducer Nipple 1/2MPT X 1/4MPT	1	S	Sold as EACH (1)
8	70184628020	238067	Reducer Fit 3/4MGH x 1/2FMPT	2	S	Sold as EACH (1)
9	70184683507	42521	Tube 1/2ID X 3/4OD 48" Long	1	S	1/2ID x 3/4" OD 48" Long Tube (Hose)
10	00310024053	232121	VALVE & CONNECTOR ASSY	1	S	Includes: Valve Assembly w/Hose Adapter (1), Male Quick Detach x 3/4" Garden Hose (1), Female Quick Detach (1) x 3/4" Garden Hose, Hex Bushing 3/4" Garden Hose x 1/2 FPT (1), and Reducing Bushing 1/2 MPT x 1/4MPT (1) NOTE: Valve Assembly w/ Hose Adapter, Male Quick Detach x 3/4" Garden Hose, and Female Quick Detach x 3/4" Garden Hose are not sold separately
11	70184632296	247129	Elbow 1/2" MPT x 1/2 FMPT x 90°	1	S	Sold as EACH (1)
12	-NA-	-NA0	USE 70184631499		S	NOT Sold Separately Only sold as part of complete water tank assembly 70184631499
13	70184632229	201203-129-0	DECAL PICTOGRAM	1	S	Center of Water Tank Bracket
14						

Decals C13PE and C14PEK

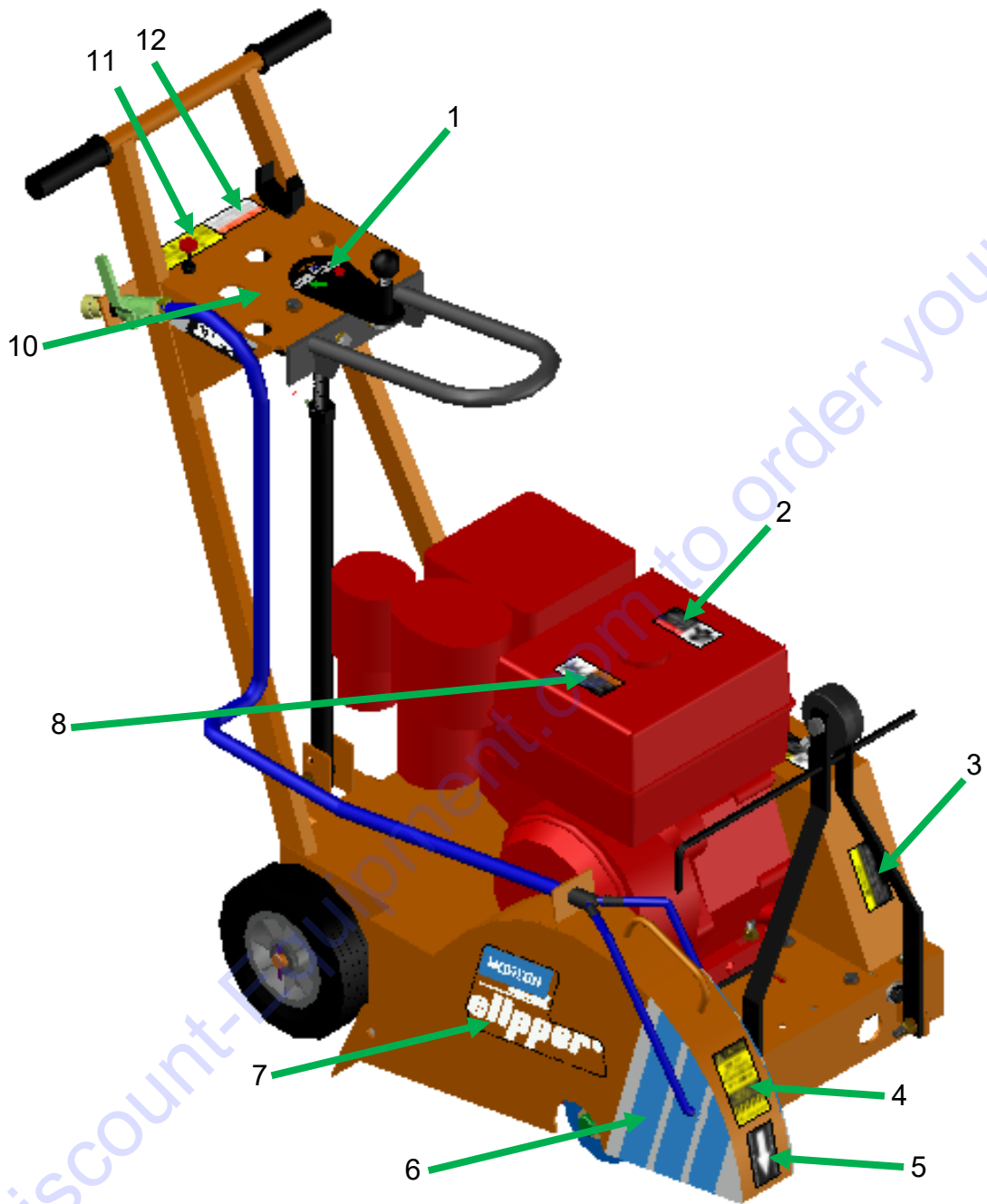

Operator's Right Side C13PE and C14PEK

Decals C13PE and C14PEK

Operator's Right Side C13PE and C14PEK					
POS	UPC	Description	QTY	NOTES	Decal Image
1	70184632317	DECAL RAISE/LOWER C13PE/C14PE	1	Top of Raise Screw Handle C13PE and C14PEK PN: 247306	
2	70184674649	DECAL DANGER LETHAL FUMES	1	Top Operator's Left Side of Fuel Tank ALL Models PN: 227243	
3	70184674634	DECAL CAUTION DISCONNECT	1	Front of Belt Guard ALL Models PN: 227239	
4	70184653268	DECAL GUARD LIFT CAUTION	1	Front of Blade Guard ALL Models PN: 108850	
5	70184632232	DECAL DIRECTIONAL ARROW BLADE GUARD	1	Front of Blade Guard ALL Models PN: 233462	
6	70184632322	DECAL NOSE STRIPE OPERATOR'S RIGHT C13PE/C14PEK	1	Blade Guard Nose Operator's RIGHT Side C13PE and C14PEK PN: 233463	
7	70184631637	DECAL NORTON CLIPPER LOGO 8.93x4.79"	1	Operators Right Side of Blade Guard and Belt Guard C13PE and C14PEK. PN: 233455	
8	70184674647	DECAL WARNING REFUELING	1	Top Operator's Right Side of Fuel Tank ALL Models PN: 227241	
9	70184632318	DECAL MODEL C13PE OPERATOR RIGHT	1	C13PE Operator's RIGHT PN: 233465	
	70184632320	DECAL MODEL C14PEK OPERATOR RIGHT		C14PEK Operator' RIGHT PN: 233906	
10	70184674481	DECAL SAFETY GEAR CAUTION	1	Top of Console ALL Models PN: 227234	
11	70184673104	DECAL PROPOSITION 65 WARNING	1	Top of Console ALL Models PN: 108934	

Decals C13PE and C14PEK

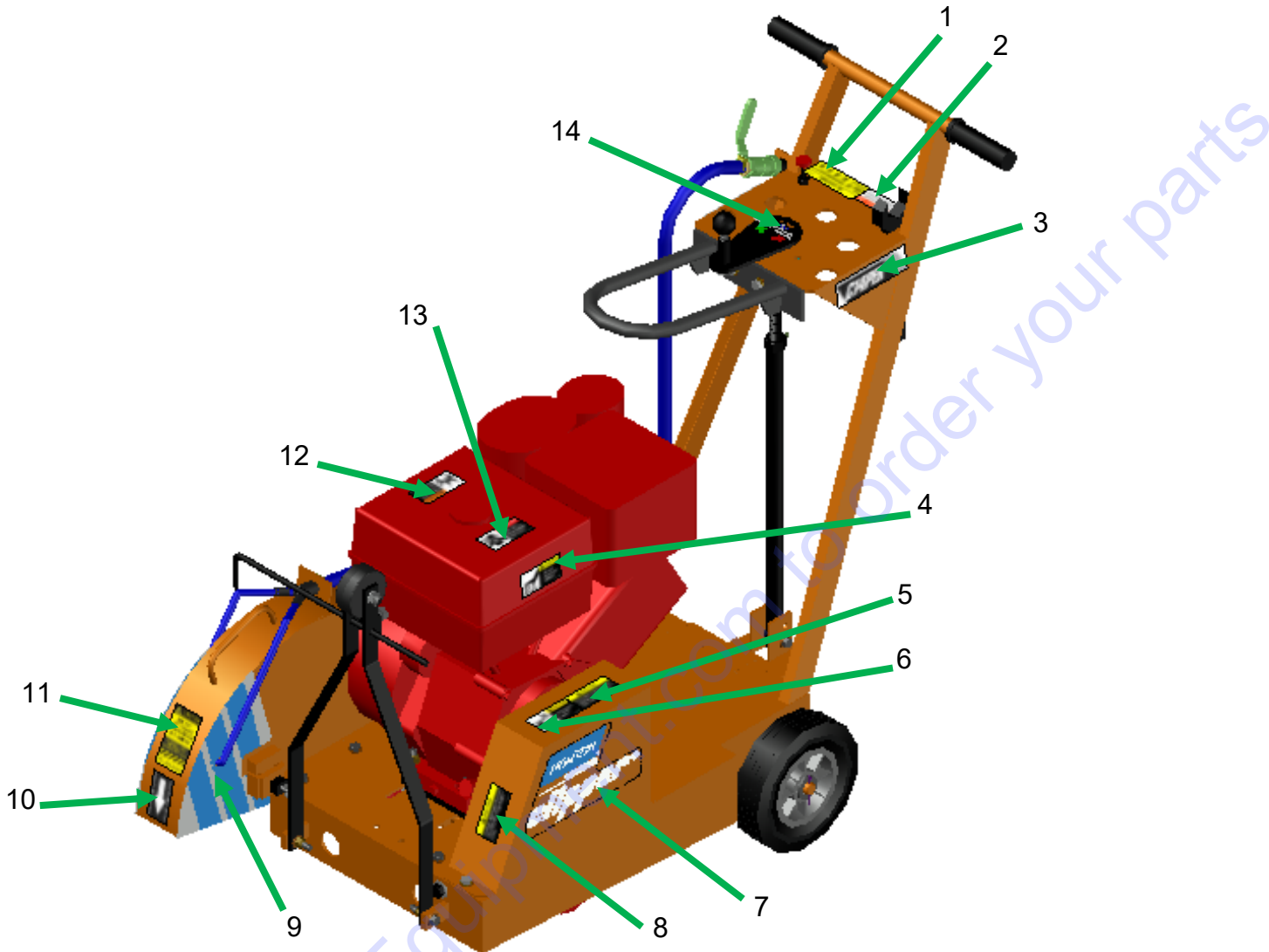

Operator's Left Side C13PE and C14PEK

Operator's Left Side C13PE and C14PEK						
POS	UPC	Description	QTY	NOTES	Decal Image	
1	70184674481	1. DECAL SAFETY GEAR CAUTION	1	Top of Console ALL Models PN: 227234		
2	70184673104	DECAL PROPOSITION 65 WARNING	1	Top of Console ALL Models PN: 108934		
3	70184632319	DECAL MODEL C13PE OPERATOR LEFT	1	C13PE Operator's LEFT PN: 233466		
	70184632321	DECAL MODEL C14PEK OPERATOR LEFT		C14PEK Operator's LEFT PN: 233907		
4	70184674630	DECAL CAUTION HOT SURFACE	1	Operator's Left Side of Fuel Tank ALL Models PN: 227235		

Decals C13PE and C14PEK

Operator's Left Side C13PE and C14PEK					
POS	UPC	Description	QTY	NOTES	Decal Image
5	70184674632	DECAL CAUTION GUARDS	1	Top of Belt Guard ALL Models PN: 227237	
6	70184674633	DECAL CAUTION BELTS	1	Top of Belt Guard ALL Models PN: 227238	
7	70184631637	DECAL NORTON CLIPPER LOGO 8.93x4.79"	2	Operators Right Side of Blade Guard and Belt Guard C13PE and C14PEK. PN: 233455	
8	70184674634	DECAL CAUTION DISCONNECT	1	Front of Belt Guard ALL Models PN: 227239	
9	70184632323	DECAL NOSE STRIPE OPERATOR'S LEFT C13PE/C14PEK	1	Blade Guard Nose Operator's LEFT Side C13PE and C14PEK PN: 233464	
10	70184632232	DECAL DIRECTIONAL ARROW BLADE GUARD	1	Front of Blade Guard ALL Models PN: 233462	
11	70184653268	DECAL GUARD LIFT CAUTION	1	Front of Blade Guard ALL Models PN: 108850	
12	70184674647	DECAL WARNING REFUELING	1	Top Operator's Right Side of Fuel Tank ALL Models PN: 227241	
13	70184674649	DECAL DANGER LETHAL FUMES	1	Top Operator's Left Side of Fuel Tank ALL Models PN: 227243	
14	70184632317	DECAL RAISE/LOWER C13PE/C14PE	1	Top of Raise Screw Handle C13PE and C14PEK PN: 247806	

PARTS FINDER

**Search Website
by Part Number**



**Search Manual
Library For Parts
Manual & Lookup Part
Numbers – Purchase
or Request Quote**

Search Manuals

Enter your information to help us find the right parts manual for your machine.

* Brand:

* Model:

* Serial:

* Part Number:

SEARCH

**Can't Find Part or
Manual? Request Help
by Manufacturer,
Model & Description**

Parts Order Form

Please fill in the following information to help us find the right part for your machine.

Manufacturer:	<input type="text"/>
Model:	<input type="text"/>
Description:	<input type="text"/>
Part Number:	<input type="text"/>
Quantity:	<input type="text"/>
Notes:	<input type="text"/>

Discount-Equipment.com is your online resource for quality parts & equipment.

Florida: **561-964-4949** Outside Florida TOLL FREE: **877-690-3101**

Need parts?

Click on this link: <http://www.discount-equipment.com/category/5443-parts/> and choose one of the options to help get the right parts and equipment you are looking for. Please have the machine model and serial number available in order to help us get you the correct parts. If you don't find the part on the website or on one of the online manuals, please fill out the request form and one of our experienced staff members will get back to you with a quote for the right part that your machine needs.

We sell worldwide for the brands: Genie, Terex, JLG, MultiQuip, Mikasa, Essick, Whiteman, Mayco, Toro Stone, Diamond Products, Generac Magnum, Airman, Haulotte, Barreto, Power Blanket, Nifty Lift, Atlas Copco, Chicago Pneumatic, Allmand, Miller Curber, Skyjack, Lull, Skytrak, Tsurumi, Husquvarna Target, Stow, Wacker, Sakai, Mi-T-M, Sullair, Basic, Dynapac, MBW, Weber, Bartell, Bennar Newman, Haulotte, Ditch Runner, Menegotti, Morrison, Contec, Buddy, Crown, Edco, Wyco, Bomag, Laymor, EZ Trench, Bil-Jax, F.S. Curtis, Gehl Pavers, Heli, Honda, ICS/PowerGrit, IHI, Partner, Imer, Clipper, MMD, Koshin, Rice, CH&E, General Equipment, Amida, Coleman, NAC, Gradall, Square Shooter, Kent, Stanley, Tamco, Toku, Hatz, Kohler, Robin, Wisconsin, Northrock, Oztec, Toker TK, Rol-Air, APT, Wylie, Ingersoll Rand / Doosan, Innovatech, Con X, Ammann, Mecalac, Makinex, Smith Surface Prep, Small Line, Wanco, Yanmar