

PARTS MANUAL



www.Discount-Equipment.com

Mikasa **SERIES**
MODEL MVB150H
PLATE COMPACTOR
(HONDA GX160UT2SMXE GASOLINE ENGINE)

Revision #1 (06/03/20)

THIS MANUAL MUST ACCOMPANY THE EQUIPMENT AT ALL TIMES.

PARTS FINDER

**Search Website
by Part Number**



**Search Manual
Library For Parts
Manual & Lookup Part
Numbers – Purchase
or Request Quote**

Search Manuals

Enter your information to search for manuals and parts.

* Brand:

* Model:

* Serial:

* Part Number:

SEARCH

**Can't Find Part or
Manual? Request Help
by Manufacturer,
Model & Description**

Parts Order Form

Please fill in the following information:

Manufacturer:

Model:

Description:

Quantity:

Part Number:

Part Name:

Part Description:

Part Category:

Part Location:

Part Status:

Part Condition:

Part Material:

Part Color:

Part Weight:

Part Dimensions:

Part Price:

Part Notes:

Submit

Discount-Equipment.com is your online resource for quality parts & equipment.

Florida: **561-964-4949** Outside Florida TOLL FREE: **877-690-3101**

Need parts?

Click on this link: <http://www.discount-equipment.com/category/5443-parts/> and choose one of the options to help get the right parts and equipment you are looking for. Please have the machine model and serial number available in order to help us get you the correct parts. If you don't find the part on the website or on once of the online manuals, please fill out the request form and one of our experienced staff members will get back to you with a quote for the right part that your machine needs.

We sell worldwide for the brands: Genie, Terex, JLG, MultiQuip, Mikasa, Essick, Whiteman, Mayco, Toro Stone, Diamond Products, Generac Magnum, Airman, Haulotte, Barreto, Power Blanket, Nifty Lift, Atlas Copco, Chicago Pneumatic, Allmand, Miller Curber, Skyjack, Lull, Skytrak, Tsurumi, Husquvarna Target, , Stow, Wacker, Sakai, Mi-T- M, Sullair, Basic, Dynapac, MBW, Weber, Bartell, Bennar Newman, Haulotte, Ditch Runner, Menegotti, Morrison, Contec, Buddy, Crown, Edco, Wyco, Bomag, Laymor, Barreto, EZ Trench, Bil-Jax, F.S. Curtis, Gehl Pavers, Heli, Honda, ICS/PowerGrit, IHI, Partner, Imer, Clipper, MMD, Koshin, Rice, CH&E, General Equipment, ,AMida, Coleman, NAC, Gradall, Square Shooter, Kent, Stanley, Tamco, Toku, Hatz, Kohler, Robin, Wisconsin, Northrock, Oztec, Toker TK, Rol-Air, Small Line, Wanco, Yanmar

TABLE OF CONTENTS

MVB150H Plate Compactor

Explanation Of Code In Remarks Column.....	4
Suggested Spare Parts	5

Compactor Component Drawings

Nameplate And Decals Assembly	6-7
Body Assembly.....	8-9
Vibrator Assembly	10-11
Roller Assembly.....	12-13
Clutch Assembly.....	14-15

Honda GX160UT2SMXE Engine

Cylinder Head Assembly	16-17
Cylinder Barrel Assembly	18-19
Crankcase Cover Assembly	20-21
Crankshaft Assembly.....	22-23
Piston Assembly	24-25
Camshaft Assembly.....	26-27
Recoil Starter Assembly	28-29
Fan Cover Assembly.....	30-31
Carburetor Assembly.....	32-33
Air Cleaner Assembly	34-35
Muffler Assembly	36-37
Fuel Tank Assembly.....	38-39
Flywheel Assembly.....	40-41
Ignition Coil Assembly	42-43
Control Assembly	44-45
Decals Assembly	46-47

NOTICE

Specifications and part numbers are subject to change without notice.

EXPLANATION OF CODE IN REMARKS COLUMN

The following section explains the different symbols and remarks used in the Parts section of this manual. Use the help numbers found on the back page of the manual if there are any questions.

NOTICE

The contents and part numbers listed in the parts section are subject to change **without notice**. Multiquip does not guarantee the availability of the parts listed.

SAMPLE PARTS LIST

NO.	PART NO.	PART NAME	QTY.	REMARKS
1	12345	BOLT	1	INCLUDES ITEMS W/%
2%		WASHER, 1/4 IN.		NOT SOLD SEPARATELY
2%	12347	WASHER, 3/8 IN. ...	1	MQ-45T ONLY
3	12348	HOSE	A/R	MAKE LOCALLY
4	12349	BEARING	1	S/N 2345B AND ABOVE

NO. Column

Unique Symbols — All items with same unique symbol (@, #, +, %, or >) in the number column belong to the same assembly or kit, which is indicated by a note in the “Remarks” column.

Duplicate Item Numbers — Duplicate numbers indicate multiple part numbers, which are in effect for the same general item, such as different size saw blade guards in use or a part that has been updated on newer versions of the same machine.

NOTICE

When ordering a part that has more than one item number listed, check the remarks column for help in determining the proper part to order.

PART NO. Column

Numbers Used — Part numbers can be indicated by a number, a blank entry, or TBD.

TBD (To Be Determined) is generally used to show a part that has not been assigned a formal part number at the time of publication.

A blank entry generally indicates that the item is not sold separately or is not sold by Multiquip. Other entries will be clarified in the “Remarks” Column.

QTY. Column

Numbers Used — Item quantity can be indicated by a number, a blank entry, or A/R.

A/R (As Required) is generally used for hoses or other parts that are sold in bulk and cut to length.

A blank entry generally indicates that the item is not sold separately. Other entries will be clarified in the “Remarks” Column.

REMARKS Column

Some of the most common notes found in the “Remarks” Column are listed below. Other additional notes needed to describe the item can also be shown.

Assembly/Kit — All items on the parts list with the same unique symbol will be included when this item is purchased.

Indicated by:

“INCLUDES ITEMS W/(unique symbol)”

Serial Number Break — Used to list an effective serial number range where a particular part is used.

Indicated by:

“S/N XXXXX AND BELOW”

“S/N XXXX AND ABOVE”

“S/N XXXX TO S/N XXX”

Specific Model Number Use — Indicates that the part is used only with the specific model number or model number variant listed. It can also be used to show a part is NOT used on a specific model or model number variant.

Indicated by:

“XXXXX ONLY”

“NOT USED ON XXXX”

“Make/Obtain Locally” — Indicates that the part can be purchased at any hardware shop or made out of available items. Examples include battery cables, shims, and certain washers and nuts.

“Not Sold Separately” — Indicates that an item cannot be purchased as a separate item and is either part of an assembly/kit that can be purchased, or is not available for sale through Multiquip.

SUGGESTED SPARE PARTS

MVB150H PLATE COMPACTOR WITH HONDA GX160UT2SMXE GASOLINE ENGINE

1 to 5 units

Qty.	P/N	Description
3.....	070100332.....	V-BELT, RPF3330
5.....	0650140480.....	SPARK PLUG, BPR6ES
1.....	28462ZH8003.....	ROPE, RECOIL STARTER
5.....	17210ZE1822.....	ELEMENT, AIR CLEANER
5.....	17218ZE0507.....	ELEMENT, AIR CLEANER OUTER
1.....	17620Z4H900.....	CAP COMPLETE, FUEL TANK
1.....	17672Z4H000.....	FUEL FILTER, FUEL TANK
4.....	930405011.....	SHOCK ABSORBER

NOTICE

Part numbers on this Suggested Spare Parts list may supersede/replace the part numbers shown in the following parts lists.

Go to Discount-Equipment.com to order your parts

NAMEPLATE AND DECALS ASSY.

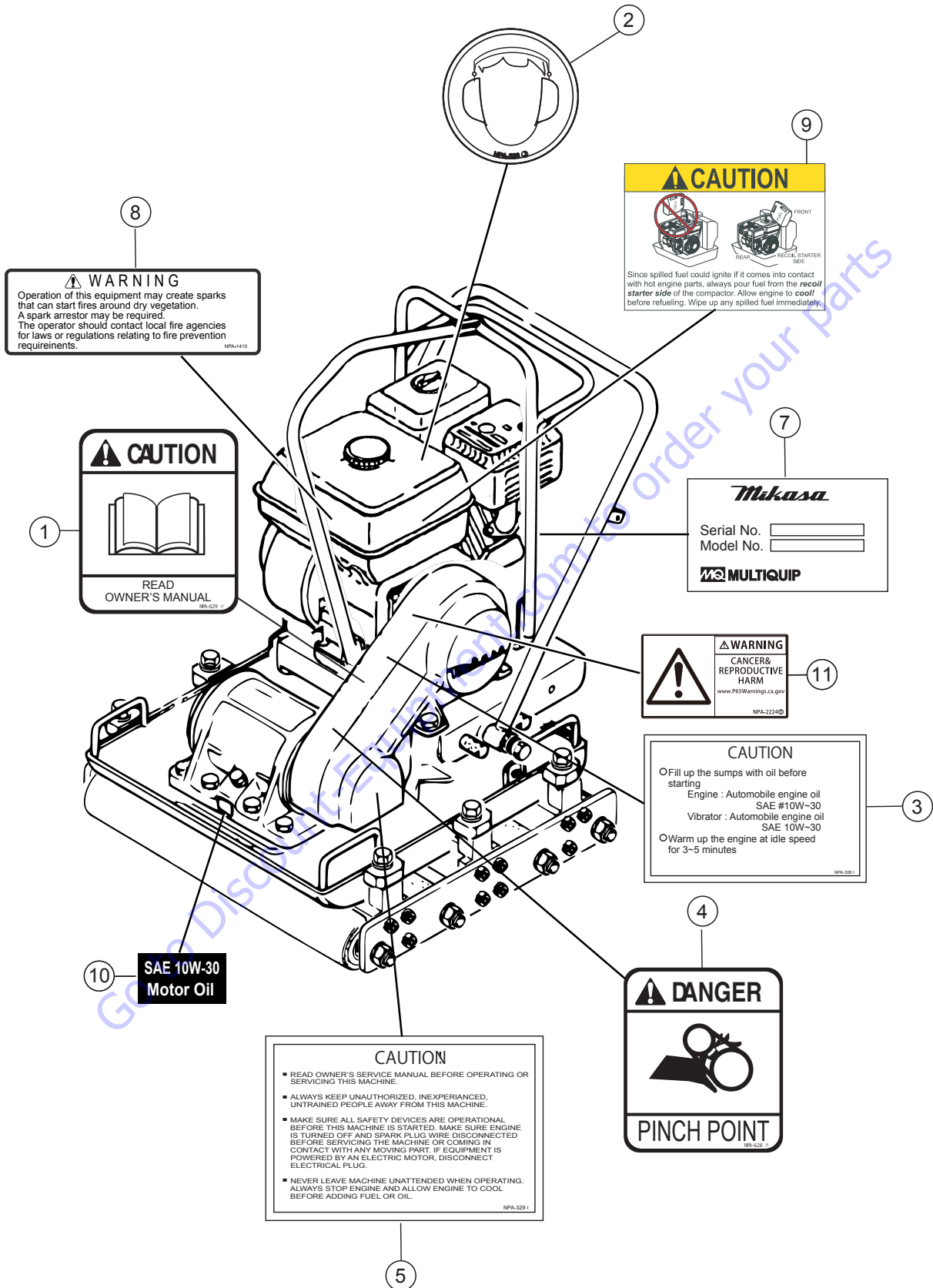

NAMEPLATE AND DECALS ASSY.

<u>NO.</u>	<u>PART NO.</u>	<u>PART NAME</u>	<u>QTY.</u>	<u>REMARKS</u>
1	920206290	DECAL, CAUTION, READ MANUAL	1	
2	920203330	EAR PROTECTION LABEL	1	
3	16089	DECAL, CAUTION, OIL FILL.....	1.....	REPLACES P/N 920203060
4	920206280	DECAL, DANGER, PINCH POINT	1	
5	920203290	DECAL, CAUTION , INSTRUCTIONS	1	
7	920223190	PLATE, SERIAL NO.....	1.....	CONTACT PARTS DEPT.
8	920214100	DECAL, E/G FIRE WARNING	1	
9	920212320	DECAL, FUEL CAUTION/MVC	1	
10	920201950	DECAL, OIL 10W-30	1	
11	920222240	DECAL, PROPOSITION 65	1	

Go to Discount-Equipment.com to order your parts

BODY ASSY.

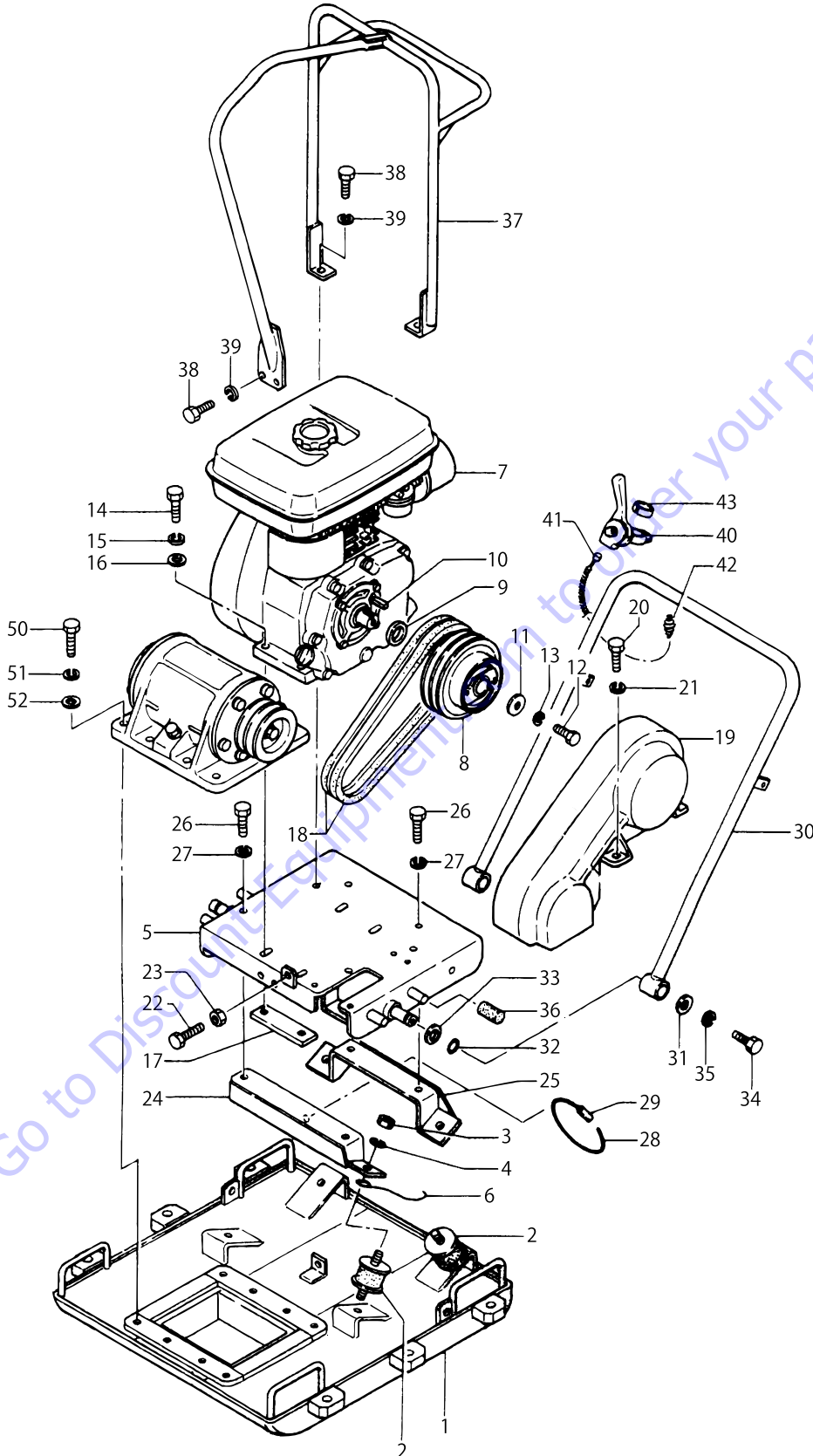

BODY ASSY.

<u>NO.</u>	<u>PART NO.</u>	<u>PART NAME</u>	<u>QTY.</u>	<u>REMARKS</u>
1	402110670	VIBRATING PLATE	1	
2	930405011	SHOCK ABSORBER	4	
3	020310080	NUT M10	4	
4	030210250	WASHER, LOCK M10	4	
5	402110680	BASE	1	
6	959404350	EARTH WIRE	1	
7	912216016	ENGINE ASSY., GX160UT2SMXE	1	
8	401326840	CLUTCH ASSY.	1	
9	952409870	CLUTCH SPACER	1	
10	0320050150	KEY	1	
11	952400130	WASHER 9304	1	
12	011208045	BOLT 8X45.....	1	REPLACES P/N 001220845
13	030208200	WASHER, LOCK M8	1	
14	011008040	BOLT 8X40.....	4	REPLACES P/N 001220840
15	030208200	WASHER, LOCK M8	4	
16	0401450080	WASHER, FLAT M8.....	4	REPLACES P/N 031108160
17	404412290	ENGINE NUT	2	
18	070100322	V-BELT, RPF-3320	2	
19	402106590	BELT COVER	1	
20	011208030	BOLT 8X30.....	4	REPLACES P/N 001220830
21	030208200	WASHER, LOCK M8	4	
22	001220840	BOLT 8X40.....	1	REPLACES P/N 011008040
23	020308060	NUT M8.....	1	REPLACES P/N 020108060
24	402211030	BRACKET, FRONT	1	
25	402328340	BRACKET, REAR	1	
26	0105091025	BOLT 10X25.....	4	REPLACES P/N 001221025
27	030210250	WASHER, LOCK M10	4	
28	402440610	WIRE, STOPPER	1	
29	402440620	CLIP, STOPPER	1	
30	402207230	HANDLE	1	
31	952402610	WASHER, 8.5X25X3	2	
32	050200160	O-RING P-16	2	
33	952402281	WASHER	2	
34	014208020	BOLT 8X20.....	2	REPLACES P/N 001220820
35	030208200	WASHER, LOCK M8	2	
36	402412450	RUBBER PIPE	4	
37	402211020	HOOK	1	
38	0105091025	BOLT 10X25.....	4	REPLACES P/N 001221025
39	030210250	WASHER, LOCK M10	4	
40	956300130	THROTTLE LEVER ASSY.	1	
41	402010070	THROTTLE WIRE	1	
42	371467760	RETURN SPRING	1	
43	959403750	RUBBER, SLIP STOP	1	
50	012212035	BOLT 12X35.....	8	REPLACES P/N 001221235
51	030212300	WASHER, LOCK M12	8	
52	031112230	WASHER, FLAT M12	8	

VIBRATOR ASSY.

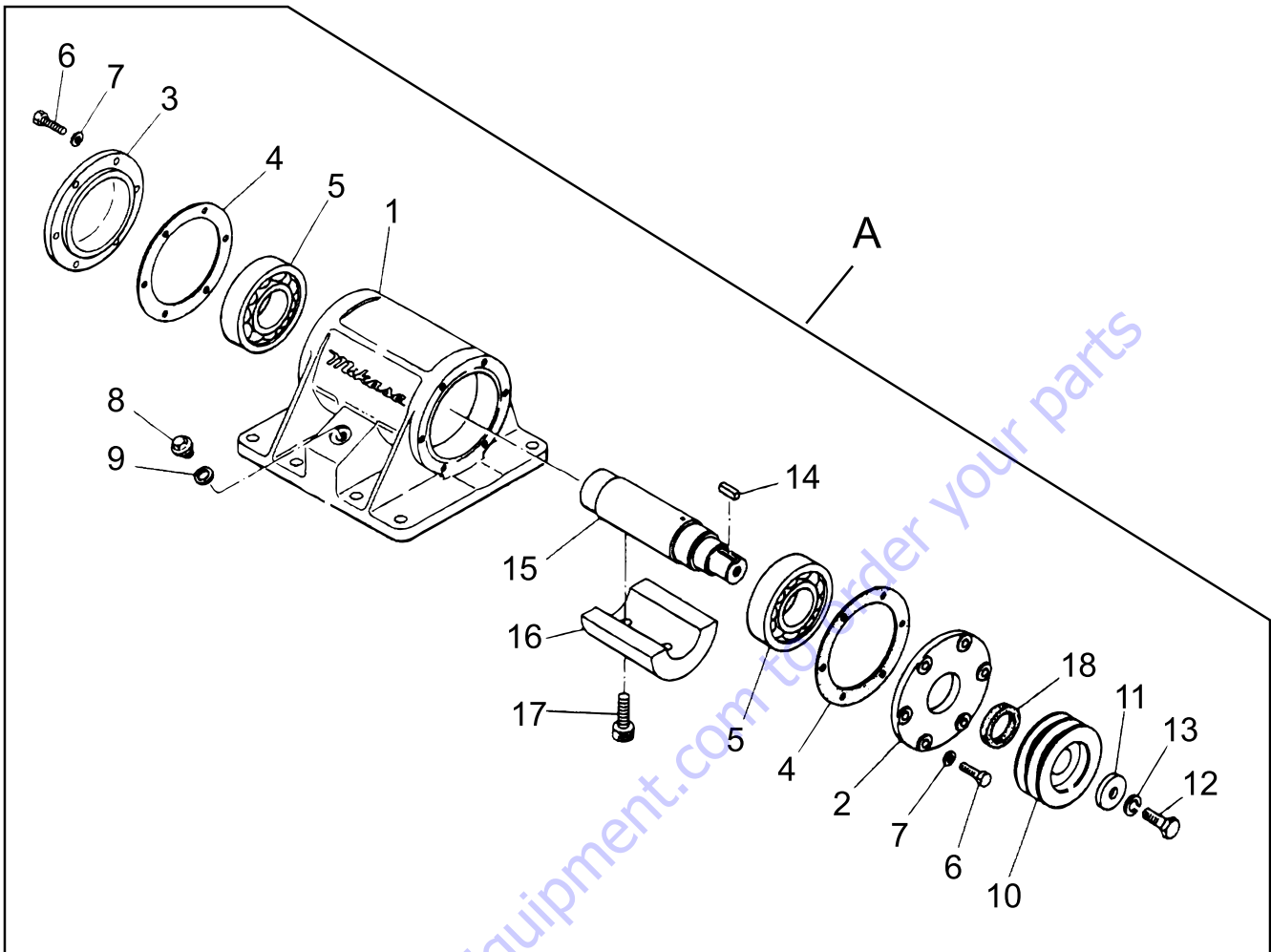

VIBRATOR ASSY.

<u>NO.</u>	<u>PART NO.</u>	<u>PART NAME</u>	<u>QTY.</u>	<u>REMARKS</u>
A	402910010	VIBRATOR ASSY.....	1.....	INCLUDES ITEMS W/\$
1\$	408010057	VIBRATING CASE	1	
2\$	401301260	CASE COVER A	1	
3\$	401301270	CASE COVER B	1	
4\$	401010190	PACKING	2	
5\$	040406309	BEARING 6309C4	2	
6\$	011208025	BOLT 8X25.....	12.....	REPLACES P/N 001220825
7\$	030208200	WASHER, LOCK M8	12	
8\$	953405270	PLUG 1/4X14X13L	1	
9\$	953405260	PACKING 1/4"	1	
10\$	401010210	PULLEY/VIB	1	
11\$	401010220	WASHER 13406	1	
12\$	001221325	BOLT 12X35 H	1	
13\$	030212300	WASHER, LOCK M12	1	
14\$	951010090	KEY 7X7X23	1	
15\$	401010200	ROTARY SHAFT	1	
16\$	401010240	ECCENTRIC ROTATOR	1	
17\$	014212030	SOCKET HEAD BOLT 12X30.....	2.....	REPLACES P/N 001521230
18\$	060403060	OIL SEAL, TC-35488	1	

Go to Discount-Equipment.com to order your parts

ROLLER ASSY.

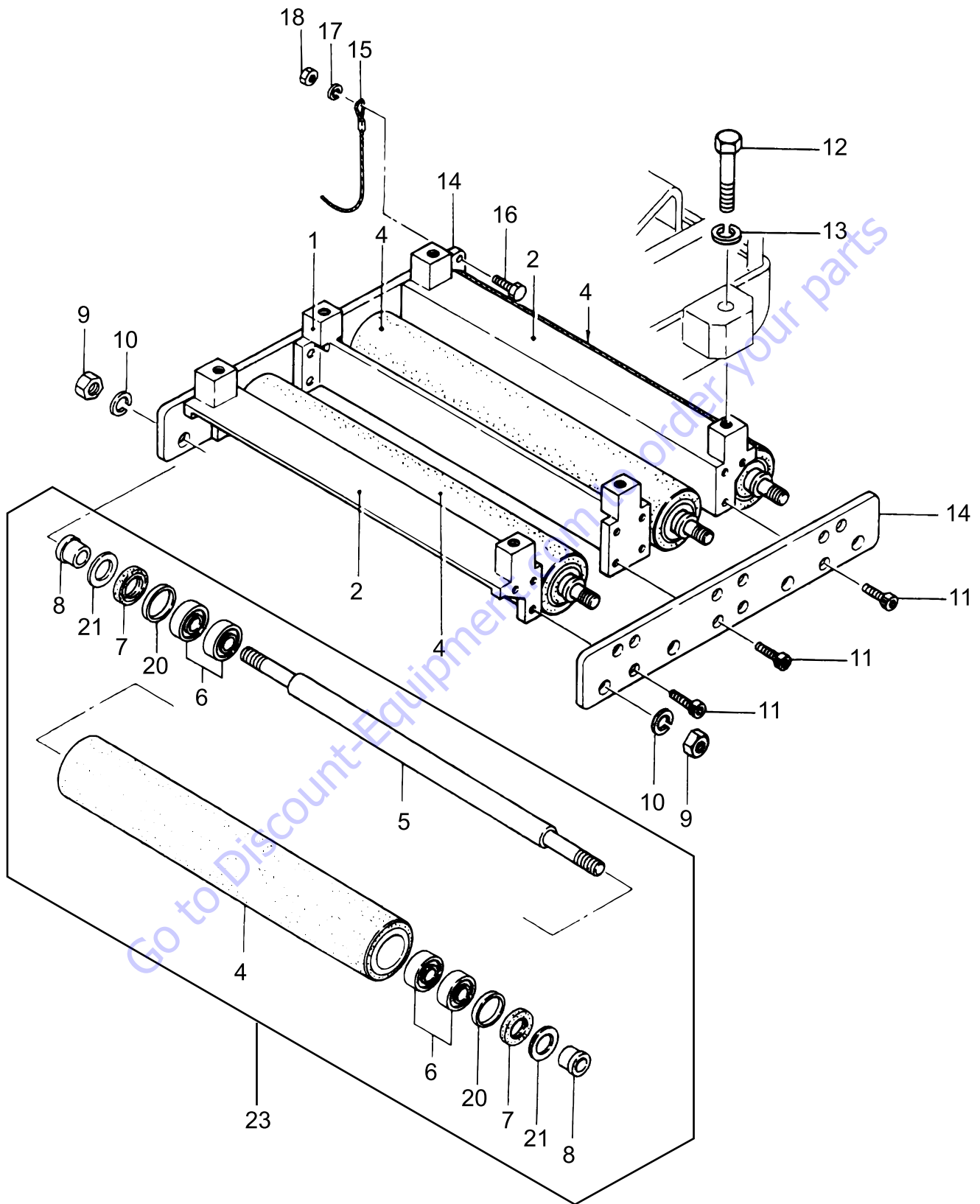

ROLLER ASSY.

<u>NO.</u>	<u>PART NO.</u>	<u>PART NAME</u>	<u>QTY.</u>	<u>REMARKS</u>
1	402328350	CENTER MEMBER	1	
2	402328360	FRAME MEMBER	2	
4\$	402329130	ROLLER	4	
5\$	402329140	ROLLER SHAFT	4	
6\$	046006304	BEARING 6304DDU	16	
7\$	060603020	OIL SEAL	8	
8\$	402441970	COLLAR	8	
9	020120160	NUT M20	8	
10	030220510	WASHER, LOCK M20	8	
11	014210020	SOCKET HEAD BOLT 10X20.....	20	REPLACES P/N 001521020
12	001222055	BOLT 20X75	6	
13	030220510	WASHER, LOCK M20	6	
14	402328550	SIDE PLATE	2	
15	959404350	EARTH WIRE	1	
16	011206020	BOLT 6X20.....	1	REPLACES P/N 001220620
17	030206150	WASHER, LOCK M6	1	
18	020106050	NUT M6.....	1	REPLACES P/N 020306050
20\$	952402180	COLLAR 46X52X5	8	
21\$	952403550	WASHER	8	
23	402910031	ROLLER ASSY.....	4	INCLUDES ITEMS W/\$

Go to Discount-Equipment.com to order your parts

CLUTCH ASSY.

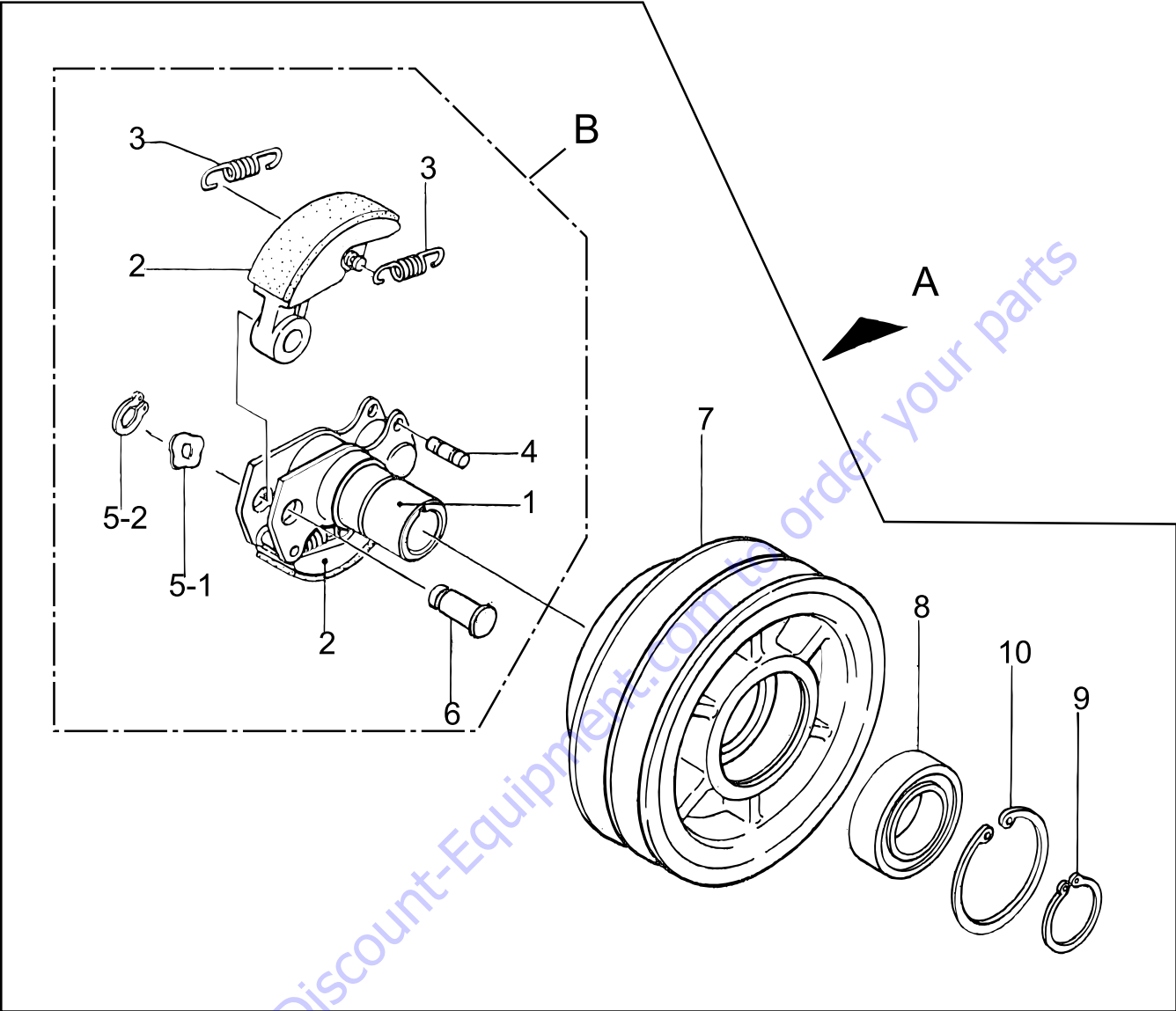

CLUTCH ASSY.

<u>NO.</u>	<u>PART NO.</u>	<u>PART NAME</u>	<u>QTY.</u>	<u>REMARKS</u>
A	402326850	CLUTCH ASSY.	1.....	INCLUDES ITEMS W/#
B#	943920110	CLUTCH SHOE ASSY.	1.....	INCLUDES ITEMS W/\$
1#\$	943040050	CLUTCH SHAFT D	1	
2#\$	943020030	CLUTCH SHOE	2	
3#\$	943030030	CLUTCH SPRING	4	
4#\$	943050080	SPRING PIN (A), CLUTCH	2	
5-1#\$	952010060	WAVE WASHER	2	
5-2#\$	080200120	STOP RING, S-12	2	
6#\$	943050071	ARM PIN	2	
7#	943010030	PULLEY DRUM	1	
8#	042006006	BEARING 6006DDU	1.....	REPLACES P/N 046006006
9#	080200300	STOP RING, S-30	1	
10#	080100550	STOP RING, R-55	1	

Go to Discount-Equipment.com to order your parts

HONDA GX160UT2SMXE ENGINE — CYLINDER HEAD ASSY.

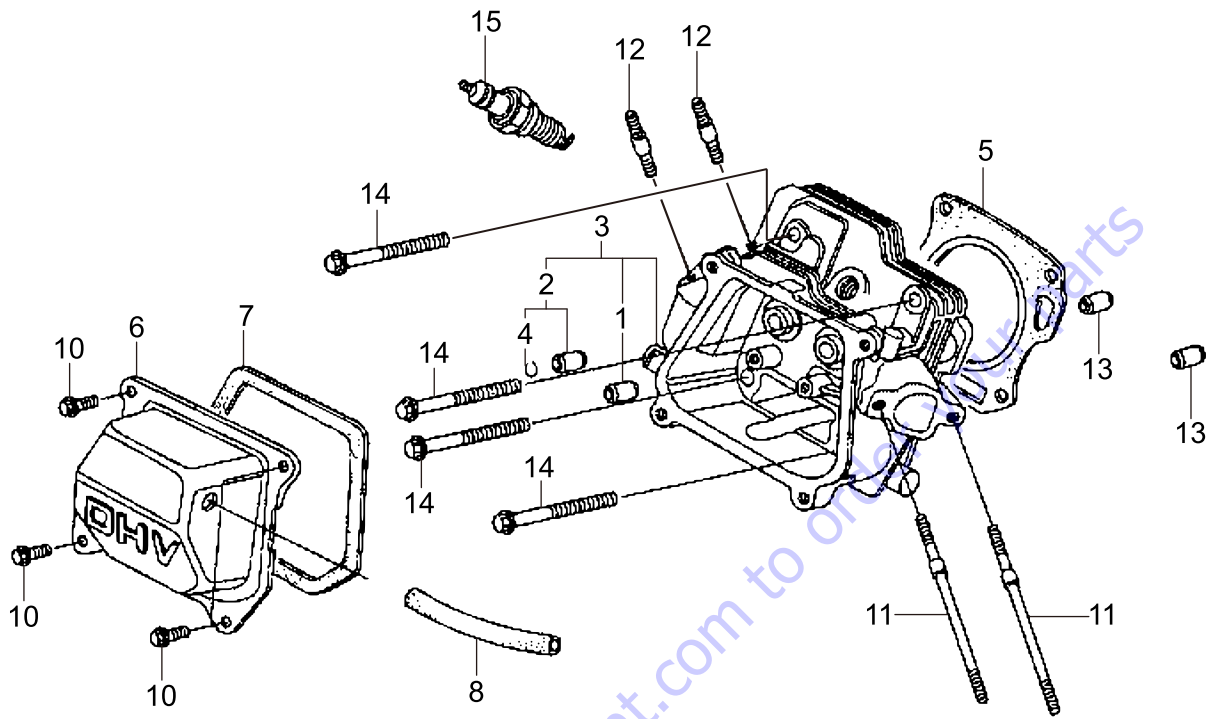

HONDA GX160UT2SMXE ENGINE — CYLINDER HEAD ASSY.

<u>NO.</u>	<u>PART NO.</u>	<u>PART NAME</u>	<u>QTY.</u>	<u>REMARKS</u>
1%	12204ZE1306	GUIDE, INLET VALVE (O.S.)	1	
2%	12205ZE1315	GUIDE, EXHAUST VALVE (O.S.).....	1.....	INCLUDES ITEM W/\$
3	12210Z4M405	HEAD COMPLETE, CYLINDER.....	1.....	INCLUDES ITEMS W/%
4\$%	12216ZE5300	CLIP, VALVE GUIDE	1	
5	12251ZL0003	GASKET, CYLINDER HEAD	1	
6	12310Z4M000	COVER COMPLETE, HEAD	1	
7	12391ZE1000	PACKING, HEAD COVER	1	
8	15721ZH8000	TUBE, BREATHER	1	
10	90013883000	FLANGE BOLT 6X12	4	
11	90043ZE1020	STUD BOLT 6X112	2	
12	90047ZE1000	STUD BOLT 8X32	2	
13	9430110160	KNOCK PIN 10X16	2	
14	957010806000	BOLT, FLANGE 8X60	4	
15	0650140480	SPARK PLUG, BPR6ES	1	

Go to Discount-Equipment.com to order your parts

HONDA GX160UT2SMXE ENGINE — CYL. BARREL ASSY.

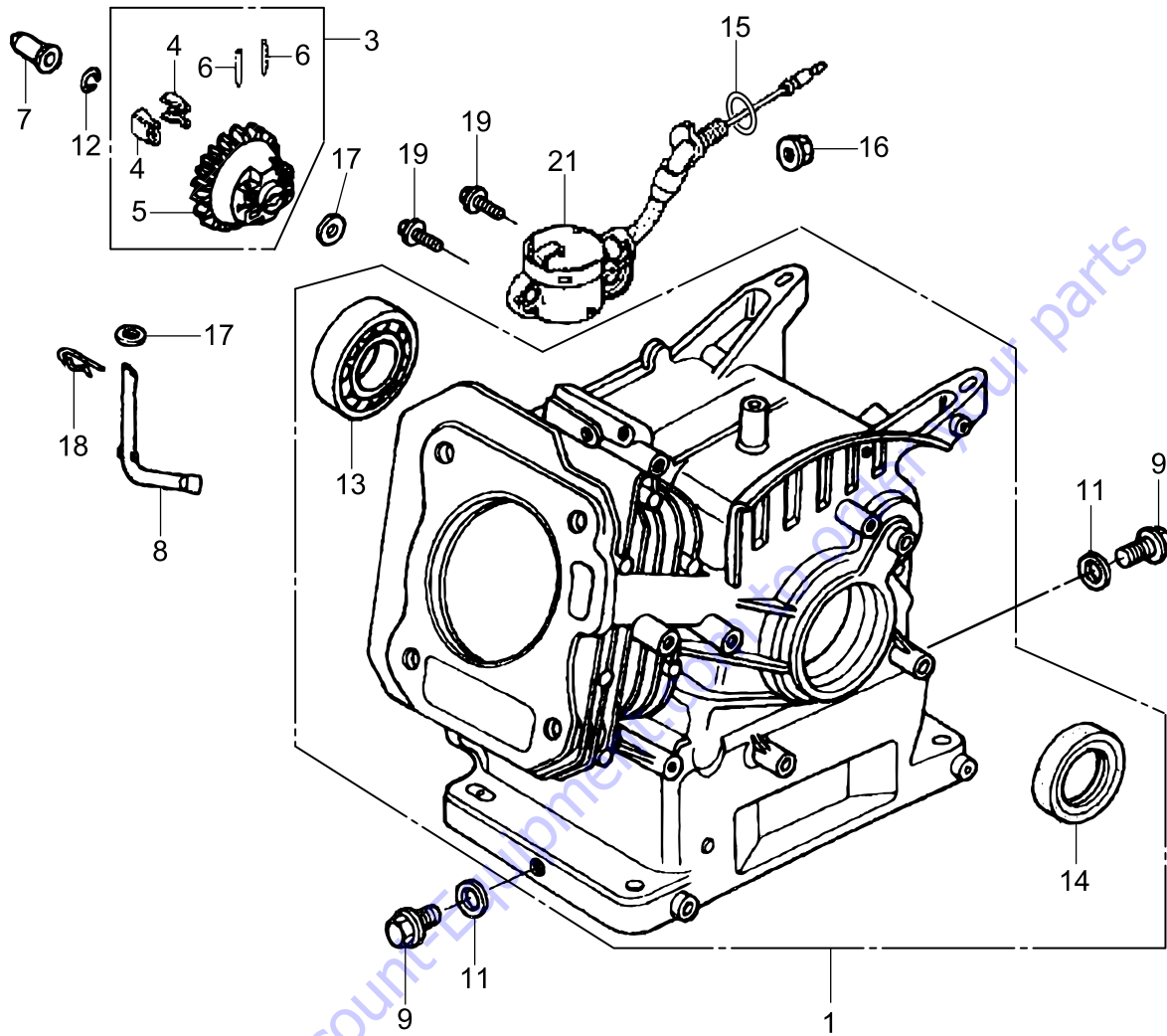

HONDA GX160UT2SMXE ENGINE — CYL. BARREL ASSY.

<u>NO.</u>	<u>PART NO.</u>	<u>PART NAME</u>	<u>QTY.</u>	<u>REMARKS</u>
1	12000Z4M416	CYLINDER BARREL ASSY. (OIL ALERT).....	1.....	INCLUDES ITEMS W/\$
3	16510Z4M000	GOVERNOR ASSY.....	1.....	INCLUDES ITEMS W/%
4%	16511Z4M000	WEIGHT, GOVERNOR	2	
5%	16512Z4M000	HOLDER, GOVERNOR WEIGHT	1	
6%	16512ZE1000	PIN, GOVERNOR WEIGHT	2	
7	16531Z4M000	SLIDER, GOVERNOR	1	
8	16541Z4M000	SHAFT, GOVERNOR ARM	1	
9	90131ZE1000	BOLT, DRAIN PLUG	2	
11	90601ZE1000	WASHER, DRAIN PLUG	2	
12	90602ZE1000	CLIP, GOVERNOR HOLDER	1	
13\$	91001ZF1003	BALL BEARING 6205	1	
14\$	91201Z0T801	OIL SEAL 25X41X6	1	
15	91353671003	O-RING, 14 MM.....	1.....	REPLACES 91353671004
16	9405010000	FLANGE NUT M10	1	
17	58176	WASHER, FLAT 6MM.....	2.....	REPLACES 9410106800
18	9425108000	LOCK PIN 8MM	1	
19	957010601200	BOLT, FLANGE 6X12	2	
21	35480Z0T003	SWITCH ASSY., OIL LEVEL	1	

Go to Discount-Equipment.com to order your parts

HONDA GX160UT2SMXE ENGINE — CRANKCASE COVER ASSY.

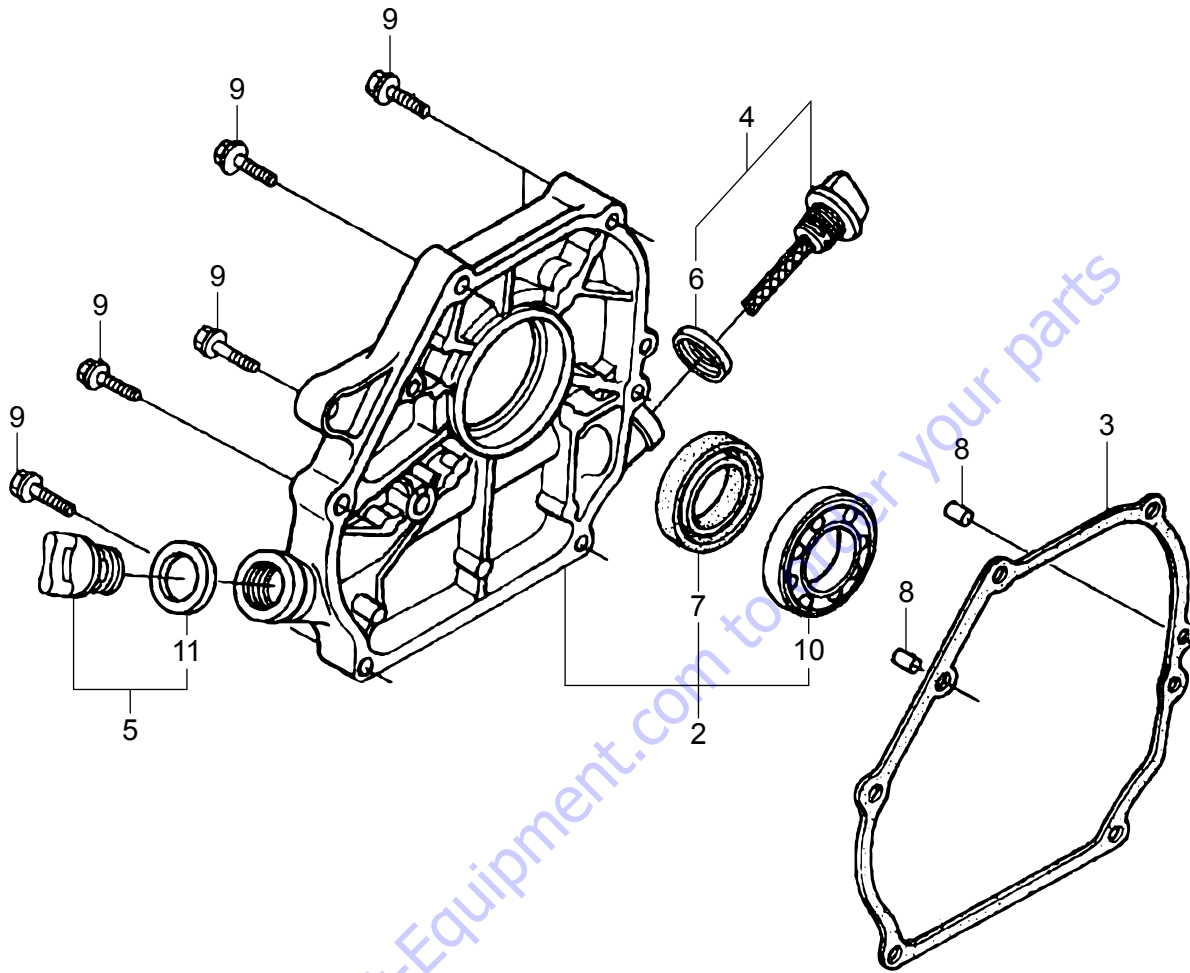

HONDA GX160UT2SMXE ENGINE — CRANKCASE COVER ASSY.

NO.	PART NO.	PART NAME	QTY.	REMARKS
2	11300Z4M630	COVER ASSY., CRANKCASE.....	1.....	INCLUDES ITEMS W/#
2	11300ZE1634	COVER ASSY., CRANKCASE.....	1.....	S/N 1043713 AND ABOVE INCLUDES ITEMS W/#
3	11381ZH8801	GASKET, CRANKCASE	1	
4	15600Z0T810	CAP ASSY., OIL FILLER, (GRAY)	1.....	INCLUDES ITEMS W/&
5	15600Z0T820	CAP ASSY., OIL FILLER	1.....	INCLUDES ITEMS W/%
6&	15625Z0T800	GASKET, OIL FILLER CAP	1	
7#	91201Z0T801	OIL SEAL 25X41X6	1	
8	9430108140	PIN A, DOWEL 8X14	2	
9	957010803200	BOLT, FLANGE 8X32	6	
10#	961006205010	BALL BEARING 6205.....	1.....	REPLACES P/N 961006205000
11%	15625Z0T800	GASKET, OIL FILLER CAP	1	

Go to Discount-Equipment.com to order your parts

HONDA GX160UT2SMXE ENGINE — CRANKSHAFT ASSY.

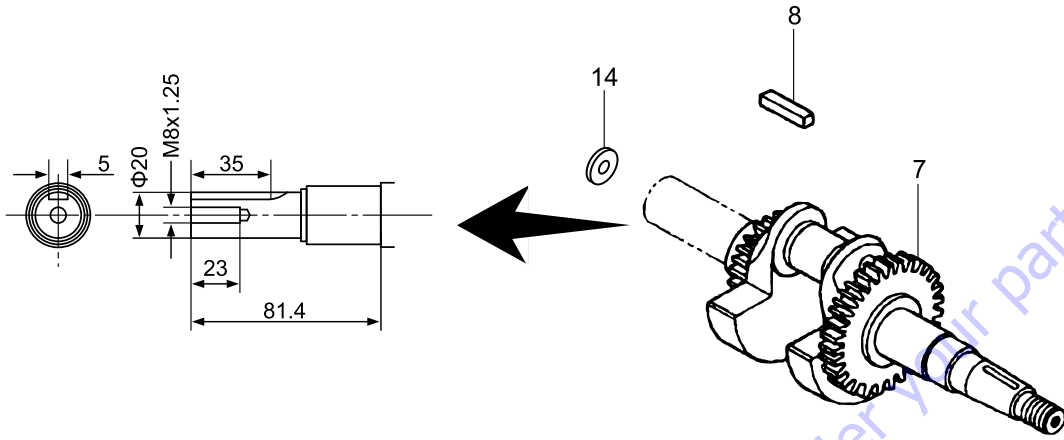

Go to Discount-Equipment.com to order your parts

HONDA GX160UT2SMXE ENGINE — CRANKSHAFT ASSY.

<u>NO.</u>	<u>PART NO.</u>	<u>PART NAME</u>	<u>QTY.</u>	<u>REMARKS</u>
7	13310Z4M880	CRANK SHAFT COMPLETE	1	
8	90741883810	KEY 5X5X33	1	
14	90473842000	WASHER 8MM	1	

Go to Discount-Equipment.com to order your parts

HONDA GX160UT2SMXE ENGINE — PISTON ASSY.

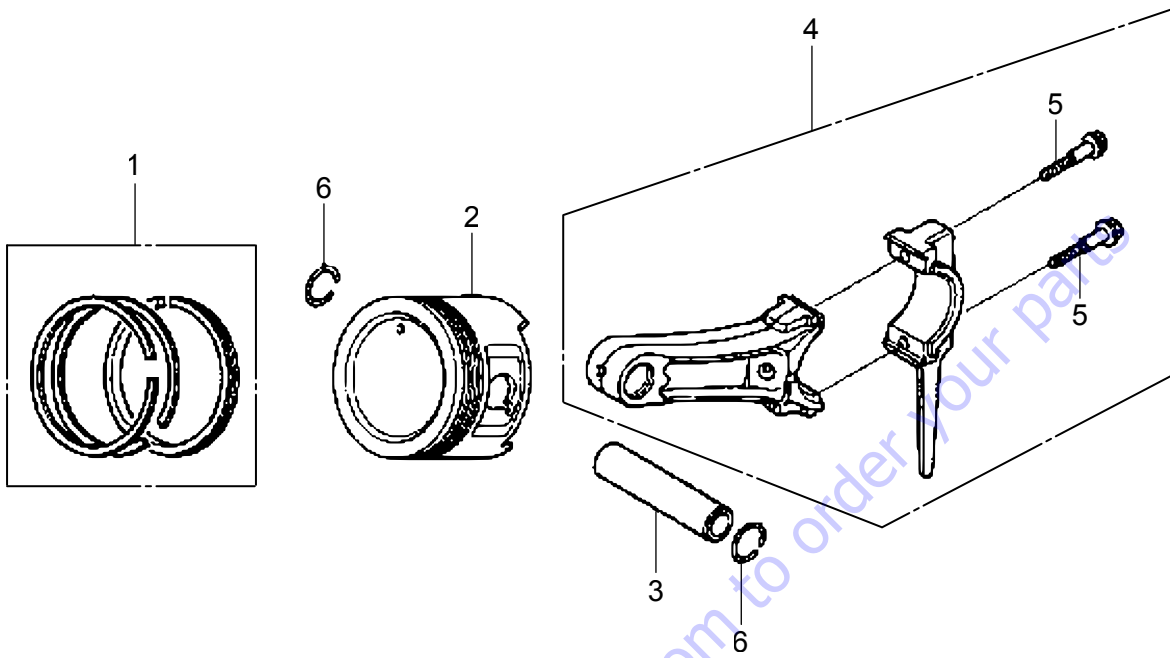

HONDA GX160UT2SMXE ENGINE — PISTON ASSY.

<u>NO.</u>	<u>PART NO.</u>	<u>PART NAME</u>	<u>QTY.</u>	<u>REMARKS</u>
1	13010Z4M801	RING SET, PISTON (STD)	1	
2	13101Z4M800	PISTON (STD)	1	
3	13111Z4M000	PIN, PISTON	1	
4	13200Z0T900	ROD ASSY., CONNECTING.....	1.....	INCLUDES ITEM W/\$
4	13210Z4M305	ROD ASSY., CONNECTING (UNDER).....	1.....	INCLUDES ITEM W/\$
5\$	90001Z4M000	BOLT, CONNECTING ROD	2	
6	90551ZE1000	CLIP, PISTON PIN 18MM	2	

Go to Discount-Equipment.com to order your parts

HONDA GX160UT2SMXE ENGINE — CAMSHAFT ASSY.

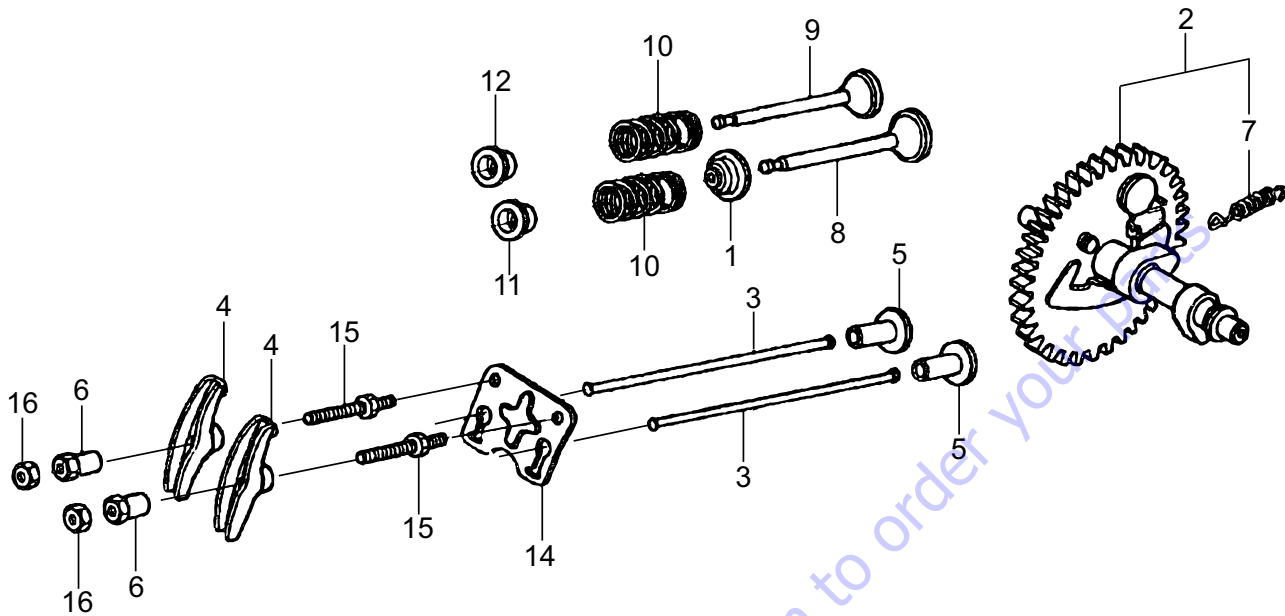

HONDA GX160UT2SMXE ENGINE — CAMSHAFT ASSY.

<u>NO.</u>	<u>PART NO.</u>	<u>PART NAME</u>	<u>QTY.</u>	<u>REMARKS</u>
1	12209Z4M801	SEAL, VALVE STEM	1	
2	14100Z4M000	CAMSHAFT ASSY.....	1	INCLUDES ITEM W/\$
3	14410Z4M000	ROD, PUSH COMPLETE	2	
4	14431ZE1000	ARM, VALVE ROCKER	2	
5	14441ZE1010	LIFTER, VALVE	2	
6	14451Z4M000	PIVOT, ROCKER ARM	2	
7\$	14568ZE1000	SPRING, WEIGHT RETURN	1	
8	14711Z4M000	VALVE, INTAKE	1	
9	14721Z4M000	VALVE, EXHAUST	1	
10	14751ZF1000	SPRING, VALVE	2	
11	14771ZE1000	RETAINER, INTAKE/EXHAUST VALVE	1	S/N 1785060 AND BELOW
11	14771Z0T900	RETAINER, VALVE SPRING.....	1	S/N 1785061 AND ABOVE
12	14771ZE1000	RETAINER, EXHAUST VALVE.....	1	S/N 1785060 AND BELOW
12	14771Z0T900	RETAINER, EXHAUST VALVE.....	1	S/N 1785061 AND ABOVE
14	14791Z4M000	PLATE, PUSH ROD GUIDE	1	
15	90012ZE0010	BOLT, PIVOT 8MM	2	
16	90206ZE1000	NUT, PIVOT ADJUSTING	2	

Go to Discount-Equipment.com to order your parts

HONDA GX160UT2SMXE ENGINE — RECOIL STARTER ASSY.

NO.	PART NO.	PART NAME	QTY.	REMARKS
1	28400Z4M305ZD	STARTER ASSY., RECOIL	1.....	INCLUDES ITEMS W/\$
1	28400Z4M306ZC	STARTER ASSY., RECOIL	1.....	S/N 2530951 AND ABOVE INCLUDES ITEMS W/\$
2\$	28410Z4M003ZD	CASE COMPLETE, RECOIL STARTER	1	
3\$	28421Z0T003	REEL, RECOIL STARTER	1	
3\$	28421Z1T702	REEL, RECOIL STARTER.....	1.....	S/N 2530951 AND ABOVE
4\$	28422ZH8801	RATCHET, STARTER	2	
4\$	28422Z1T701	RATCHET, STARTER.....	2.....	S/N 2530951 AND ABOVE
5\$	28431ZH8801	PLATE, FRICTION	1	
6\$	28433ZH8801	RATCHET GUIDE	1	
6\$	28433Z1T702	RATCHET GUIDE	1.....	S/N 2530951 AND ABOVE
7\$	28441ZH8801	FRICTION SPRING	1	
8\$	28442ZH8003	SPRING, RECOIL STARTER	1	
9\$	28443ZH8801	SPRING, RETURN	2	
9\$	28443Z1T701	SPRING, RETURN	2.....	S/N 2530951 AND ABOVE
11\$	28462ZH8003	ROPE, RECOIL STARTER	1	
12\$	90003ZH8801	SET SCREW	1	
13	90008ZE2003	BOLT, FLANGE 6X10	3	
15\$	28461Z4M305	KNOB, RECOIL STARTER	1	
16\$	28463Z4M003	KNOB, REINFORCEMENT	1	

Go to Discount-Equipment.com to order your parts

HONDA GX160UT2SMXE ENGINE — FAN COVER ASSY.

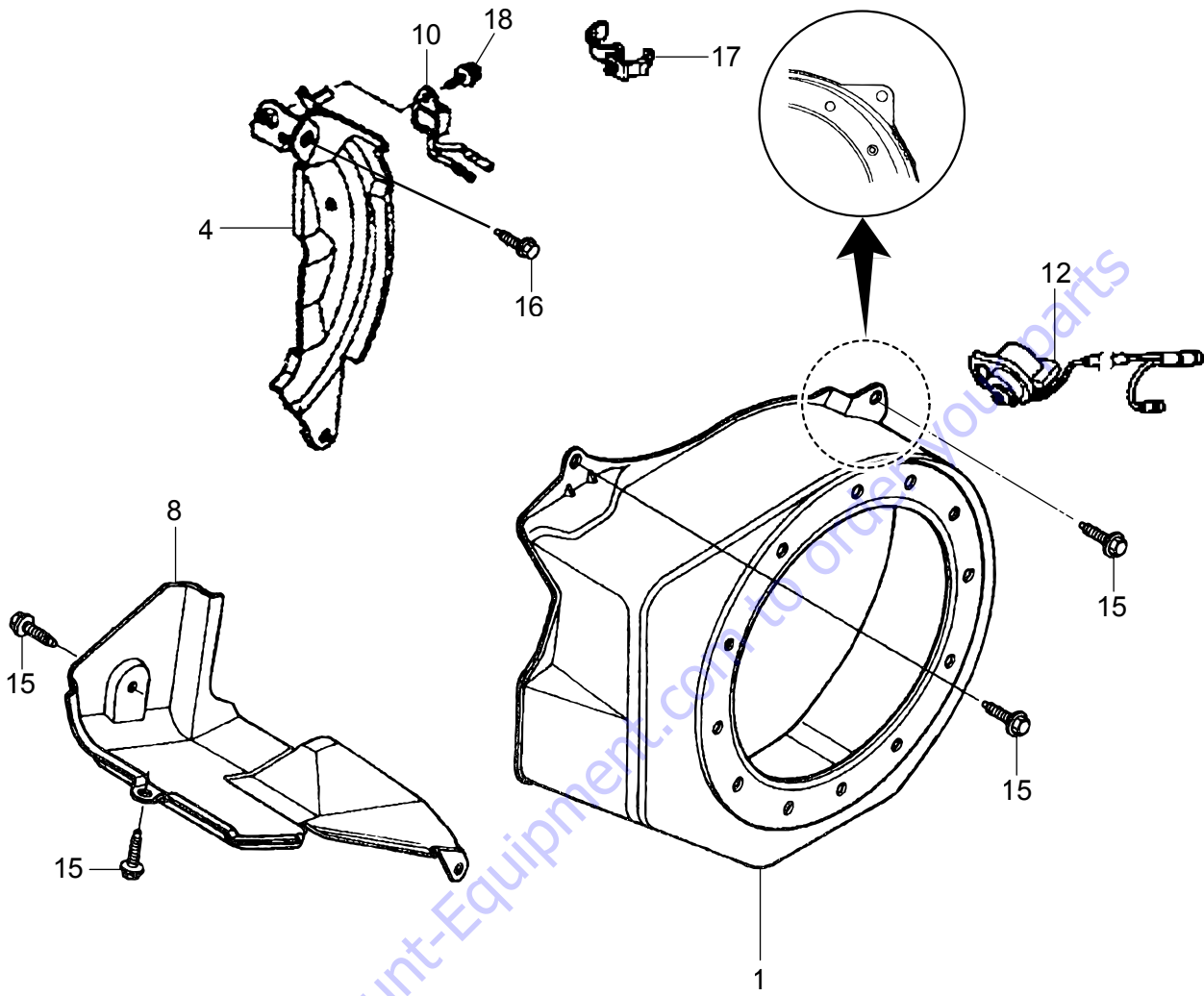

HONDA GX160UT2SMXE ENGINE — FAN COVER ASSY.

<u>NO.</u>	<u>PART NO.</u>	<u>PART NAME</u>	<u>QTY.</u>	<u>REMARKS</u>
1	19610ZE0000ZB	COVER COMPLETE, FAN BLACK	1	
4	19611Z4M810	PLATE COMPLETE, SIDE (OIL ALERT)	1	
8	19630Z4M000	SHROUD COMPLETE	1	
10	34150ZH7023	ALERT UNIT, OIL	1	
12	35120Z0T831	SWITCH ASSY., E/G STOP	1	
15	90013883000	FLANGE BOLT 6X12	6	
16	90022888010	FLANGE BOLT 6X20	1	
17	90601ZH7013	CLIP, HARNESS	1	
18	957010600800	FLANGE BOLT 6X8	1	

Go to Discount-Equipment.com to order your parts

HONDA GX160UT2SMXE ENGINE — CARBURETOR ASSY.

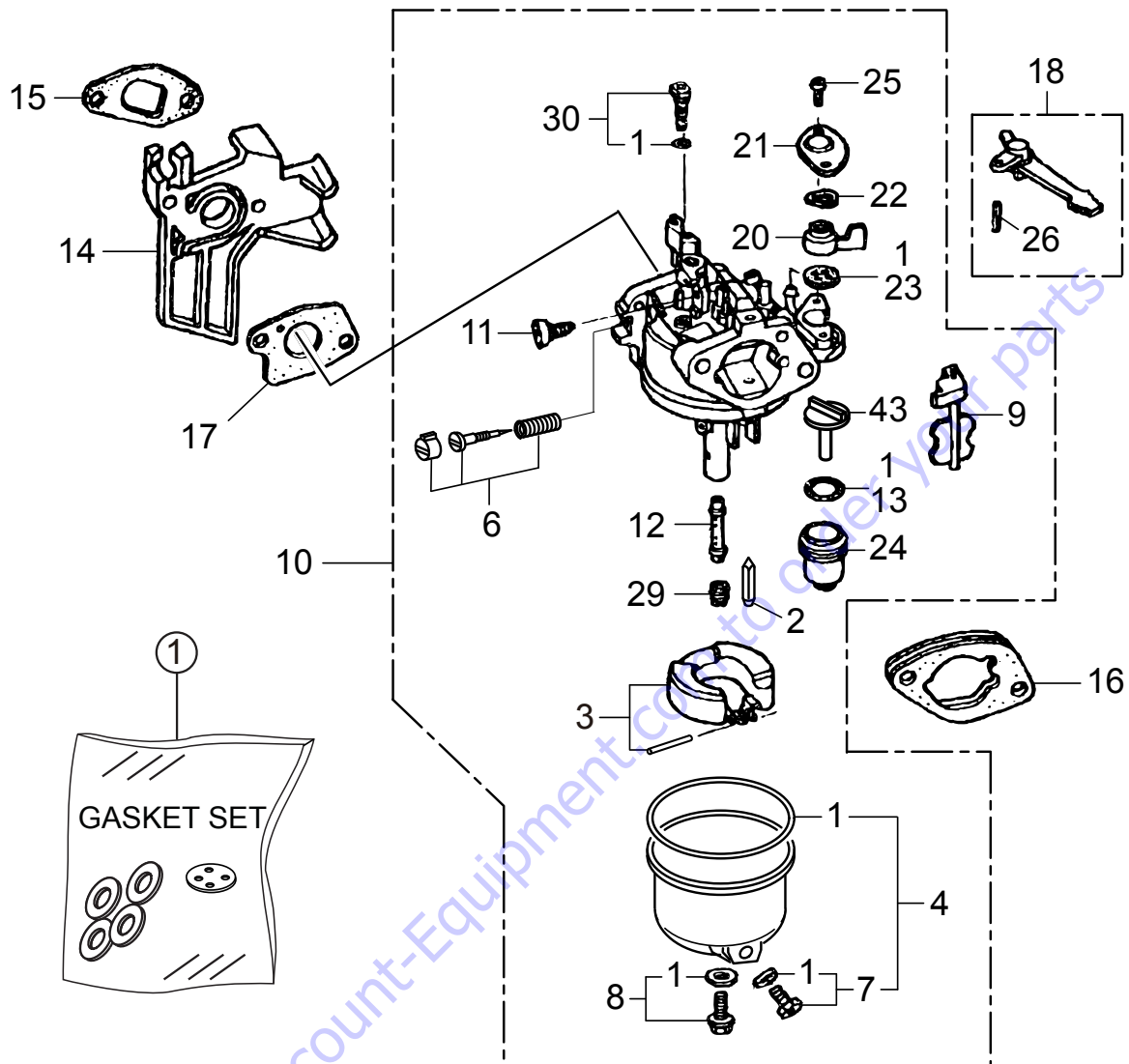

NOTICE

Gasket set, item 1 included with items 4, 7, 8, 13, 23 and 30.

HONDA GX160UT2SMXE ENGINE — CARBURETOR ASSY.

NO.	PART NO.	PART NAME	QTY.	REMARKS
1#%	16010ZE1812	GASKET SET	1	INCLUDES ITEMS W/@
2#	16011ZE0005	FLOAT VALVE SET	1	
3#	16013Z0SB01	FLOAT SET	1	
4@#	16015Z4M911	CHAMBER SET, FLOAT	1	INCLUDES ITEM W/%,&
6#	16016ZH7W01	SCREW SET, PILOT	1	
7@#&	16024Z5T901	SCREW SET, DRAIN.....	1	INCLUDES ITEM W/%
8@#	16028Z5T901	SCREW SET.....	1	INCLUDES ITEM W/%
9#	16044Z4M911	CHOKE SET	1	
10	16100Z4M922	CARBURETOR ASSY.....	1	INCLUDES ITEMS W/#
11#	16124ZE0005	SCREW, THROTTLE STOP	1	
12#	16166Z4M922	NOZZLE, MAIN	1	
13@#	16075GHBB00	O-RING.....	1	INCLUDES ITEM W/% REPLACES P/N 16955283000
14	16211Z4M000	INSULATOR, CARBURETOR	1	
15	16212ZH8800	PACKING, INSULATOR	1	
16	16220ZE1020	SPACER COMPLETE, CARBURETOR	1	
17	16221ZH8801	PACKING, CARBURETOR	1	
18	16610ZE1000	CHOKE LEVER COMPLETE.....	1	INCLUDES ITEM W/\$
20#	16953ZE1812	LEVER, COCK	1	
21#	16954ZE1812	PLATE, LEVER SETTING	1	
22#	16956ZE1811	SPRING, COCK LEVER	1	
23@#	16957ZE1812	PACKING, FUEL COCK.....	1	INCLUDES ITEM W/%
24#	16967ZE0811	CUP, FUEL STRAINER	1	
25#	93500030060H	SCREW 3X6	2	
26\$	9430520122	SPRING PIN 2X12	1	
29#	99101ZH80650	MAIN JET #65	1	
29#	99101ZH70650	MAIN JET #68.....	1	REPLACES P/N 99101ZH80650
30@#	99204ZE00350	PILOT, JET SET #35.....	1	INCLUDES ITEM W/%
43#	16959Z5T901	FILTER, CUP	1	

HONDA GX160UT2SMXE ENGINE — AIR CLEANER ASSY.

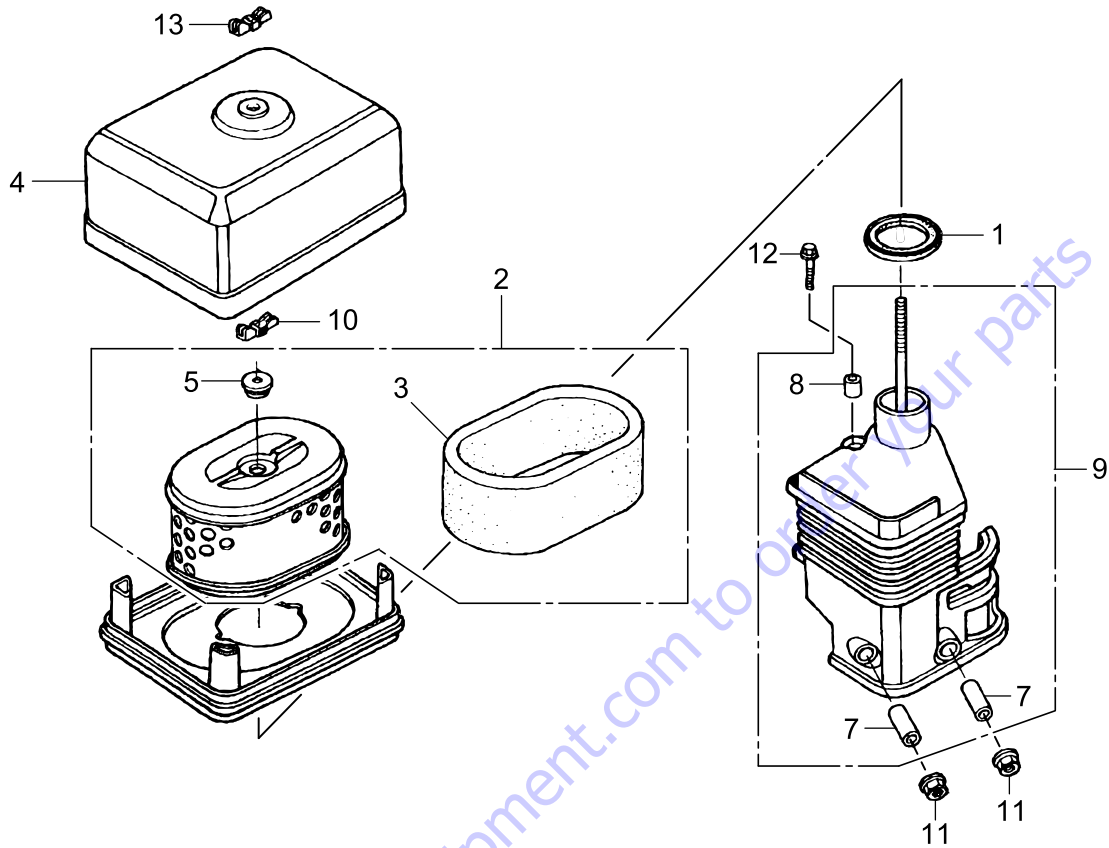

HONDA GX160UT2SMXE ENGINE — AIR CLEANER ASSY.

<u>NO.</u>	<u>PART NO.</u>	<u>PART NAME</u>	<u>QTY.</u>	<u>REMARKS</u>
1	16271ZE1000	PACKING, ELBOW	1	
2	17210ZE1517	ELEMENT, AIR CLEANER	1.....	INCLUDES ITEMS W/# REPLACES P/N 17210ZE1822
3#	17218ZE0507	OUTER ELEMENT	1	
4	17231Z4M010	COVER, AIR CLEANER	1	
5#	17232891000	GROMMET, AIR CLEANER	1	
7%	17238ZE7010	COLLAR, AIR CLEANER	2	
8%	17239ZE1000	COLLAR (B), AIR CLEANER	1	
9	17410Z4M000	ELBOW COMPLETE, AIR CLEANER	1.....	INCLUDES ITEMS W/%
10	90325044000	NUT, TOOL BOX SETTING	1	
11	9405006000	FLANGE NUT 6MM	2	
12	957010602000	FLANGE BOLT 6X20	1	
13	90300Z1V000	NUT, AIR CLEANER	1	

Go to Discount-Equipment.com to order your parts

HONDA GX160UT2SMXE ENGINE — MUFFLER ASSY.

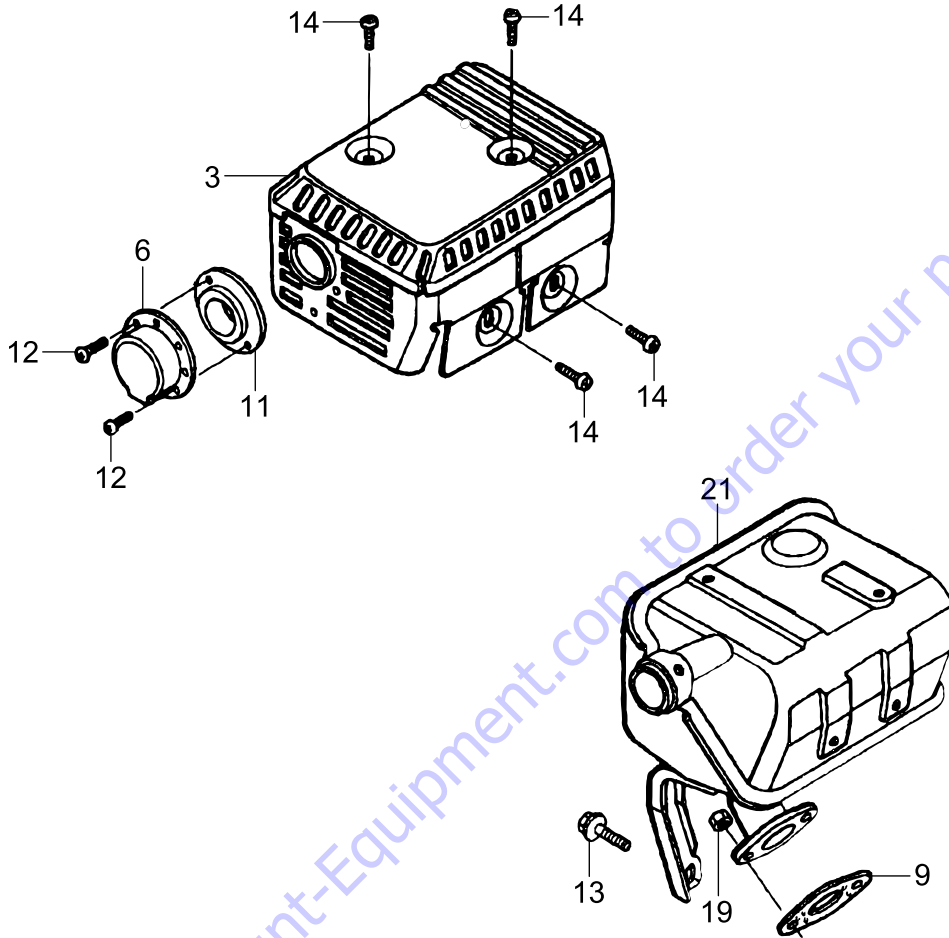

HONDA GX160UT2SMXE ENGINE — MUFFLER ASSY.

<u>NO.</u>	<u>PART NO.</u>	<u>PART NAME</u>	<u>QTY.</u>	<u>REMARKS</u>
3	18320Z4M000	PROTECTOR COMPL., MUFFLER (STD)	1	
6	18340ZE1010	DEFLECTOR COMPLETE	1	
7	18355ZE1000	ARRESTER, SPARK	1	
9	18381Z0T801	GASKET, MUFFLER	1	
11	18522ZE1000	GUIDE, MUFFLER	1	
12	90002Z0T800	SCREW, TAPPING, 4X8	2	
13	90016ZE1000	FLANGE BOLT 6X13	1	
14	90050ZE1000	SCREW, TAPPING, 5X8	4	
19	020108060	NUT 8MM.....	2	REPLACES P/N 94001080000S
21	18310Z4MV51	MUFFLER COMPLETE	1	

Go to Discount-Equipment.com to order your parts

HONDA GX160UT2SMXE ENGINE — FUEL TANK ASSY.

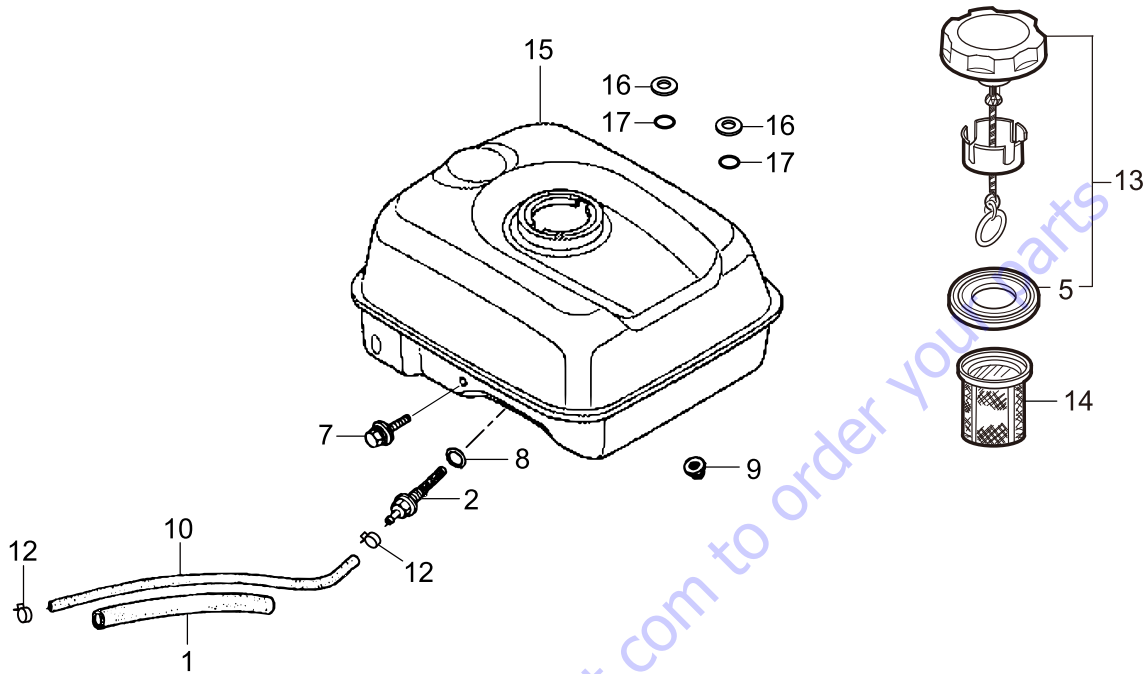

HONDA GX160UT2SMXE ENGINE — FUEL TANK ASSY.

<u>NO.</u>	<u>PART NO.</u>	<u>PART NAME</u>	<u>QTY.</u>	<u>REMARKS</u>
1	16854ZH8000	RUBBER, SUPPORT (107MM)	1	
2	16955ZE1010	JOINT, FUEL TANK	1	
5%	17631Z0T801	PACKING, FUEL FILLER CAP	1	
7	90004ZH7003	FLANGE BOLT, 6X29	1	
8	91353671003	O-RING, 14MM.....	1	REPLACES P/N 91353671004
9	9405006000	FLANGE NUT, 6MM	2	
10	91424Z4M003	TUBE, FUEL 4.5X145	1	
12	950024080008	CLAMP, TUBE (D8)	2	
13	17620Z4H900	CAP COMPLETE, FUEL TANK.....	1	INCLUDES ITEM W/%
14	17672Z4H000	FUEL FILTER, FUEL TANK	1	
15	17510Z4M000ZB	FUEL TANK COMPLETE, NH1, BLK	1	
16	90503898000	WASHER, TANK CUSHION 6.5X25X1.5	2	
17	91302Z4M003	O-RING 5.5X1.5	2	

Go to Discount-Equipment.com to order your parts

HONDA GX160UT2SMXE ENGINE — FLYWHEEL ASSY.

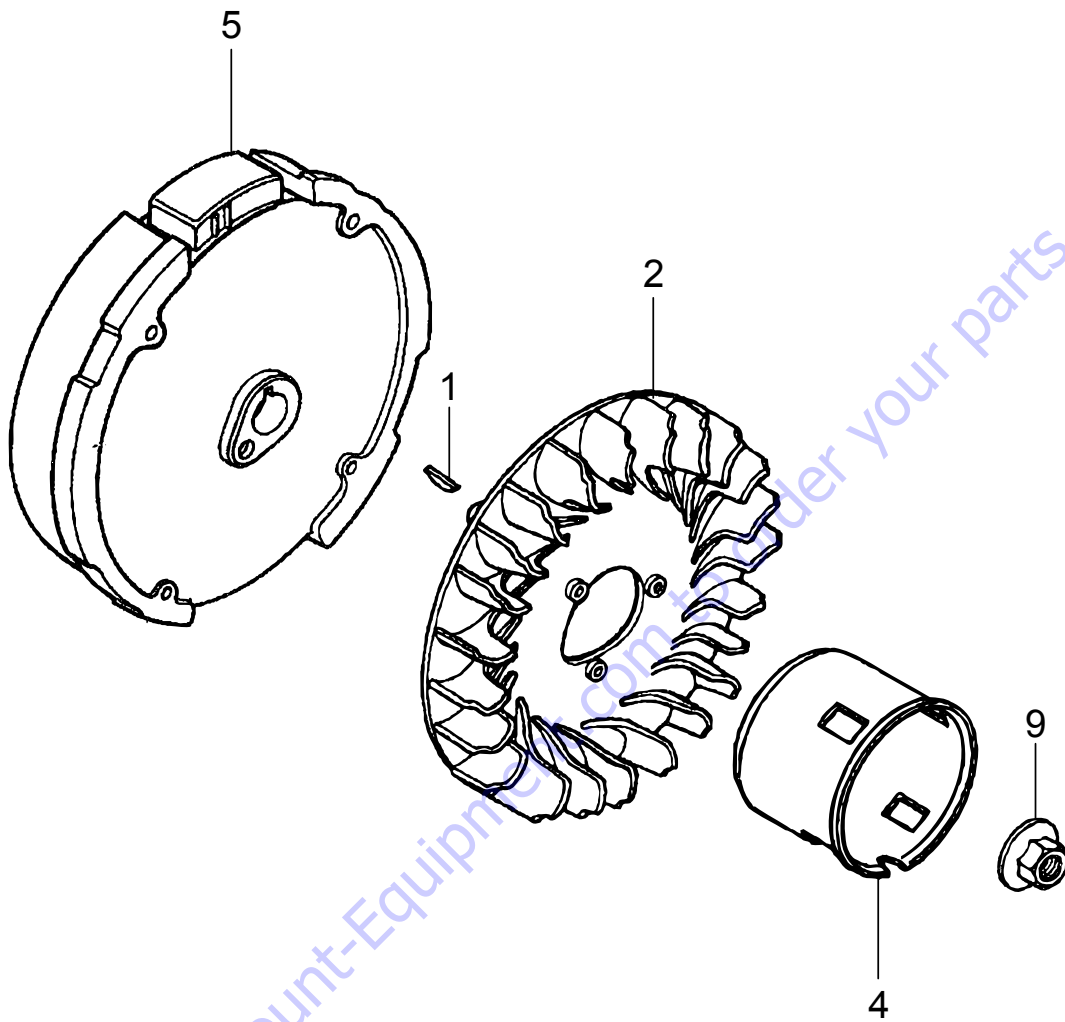

HONDA GX160UT2SMXE ENGINE — FLYWHEEL ASSY.

<u>NO.</u>	<u>PART NO.</u>	<u>PART NAME</u>	<u>QTY.</u>	<u>REMARKS</u>
1	13331357000	WOODRUFF KEY 25X18	1	
2	19511ZE1000	COOLING FAN	1	
4	28451ZH8801	STARTER, PULLEY	1.....	S/N 2530950 AND BELOW
4	28451Z4M003	STARTER, PULLEY	1.....	S/N 2530951 AND ABOVE
5	31100Z4M000	FLYWHEEL COMPLETE	1	
9	90201Z0T800	NUT, SPECIAL 14MM	1	

Go to Discount-Equipment.com to order your parts

HONDA GX160UT2SMXE ENGINE — IGNITION COIL ASSY.

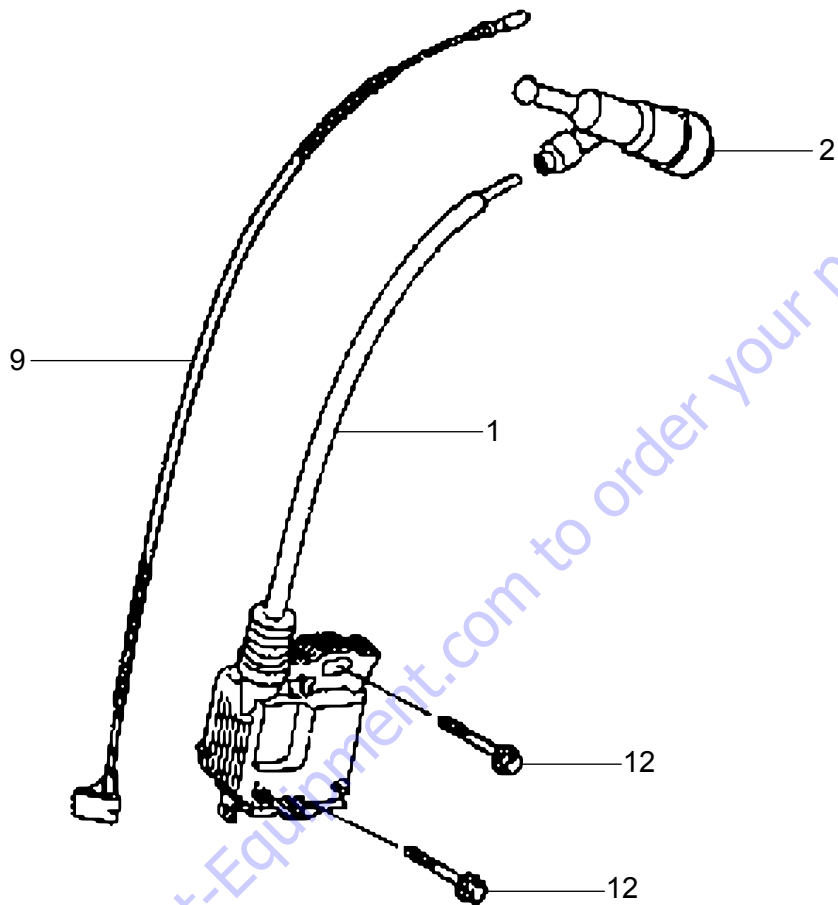

HONDA GX160UT2SMXE ENGINE — IGNITION COIL ASSY.

<u>NO.</u>	<u>PART NO.</u>	<u>PART NAME</u>	<u>QTY.</u>	<u>REMARKS</u>
1	30500Z0T003	COIL ASSY., IGNITION	1	
2	30700Z0T821	CAP ASSY., NOISE SUPPRESSOR	1	
9	36101ZE1010	CORD, STOP SWITCH 370MM.....	1.....	S/N 2204187 AND BELOW
9	32195Z0T003	CORD, STOP SWITCH 370MM.....	1.....	S/N 2204188 AND ABOVE
12	957010602500	BOLT, FLANGE 6X25.....	2.....	REPLACES P/N 90121952000

Go to Discount-Equipment.com to order your parts

HONDA GX160UT2SMXE ENGINE — CONTROL ASSY.

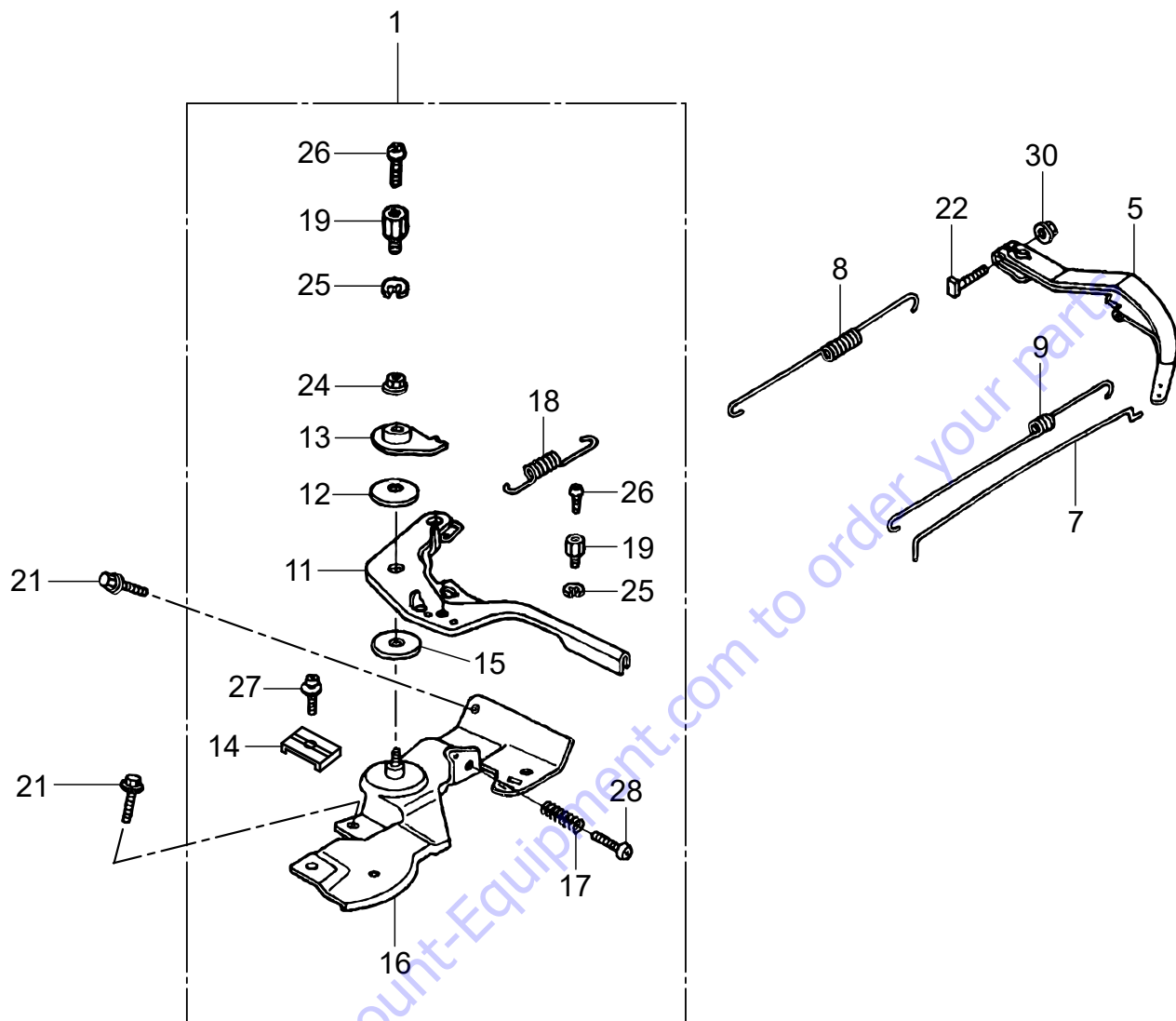

HONDA GX160UT2SMXE ENGINE — CONTROL ASSY.

<u>NO.</u>	<u>PART NO.</u>	<u>PART NAME</u>	<u>QTY.</u>	<u>REMARKS</u>
1	16500Z4M309	CONTROL ASSY.....	1	INCLUDES ITEMS W/#
5	16551Z4M000	ARM, GOVERNOR	1	
7	16555Z4M000	ROD, GOVERNOR	1	
8	16561Z4M010	SPRING, GOVERNOR	1	
9	16562Z4M000	SPRING, THROTTLE RETURN	1	
11#	16571Z4M000	LEVER, CONTROL	1	
12#	16574ZE1000	SPRING, LEVER	1	
13#	16575ZH8000	WASHER, CONTROL LEVER	1	
14#	16576891000	HOLDER, CABLE	2	
15#	16578ZE1000	SPACER, CONTROL LEVER	1	
16#	16580Z4M810	BASE CONTROL	1	
17#	16584883300	SPRING, CONTROL ADJUSTING	1	
18#	16592ZE1810	SPRING, CABLE RETURN	1	
19#	16594883010	HOLDER, WIRE	2	
21	90013883000	BOLT, FLANGE 6X12	1	
22	90015ZE5010	BOLT, GOVERNOR ARM.....	1	S/N 1451907 AND BELOW
22	90015Z5T000	BOLT, GOVERNOR ARM.....	1	S/N 1451908 AND ABOVE
24#	90114SA0000	NUT, SELF-LOCK 6MM	1	
25#	90605230000	CIRCLIP, 5 MM	2	
26#	0043504060	SCREW 4X6	2	REPLACES P/N 93500040060H
27#	0202005T125	SCREW, PAN 5X16	2	REPLACES P/N 93500050160A
28#	93500050250H	SCREW, PAN 5X25	1	
30	9405006000	NUT, FLANGE 6MM	1	

Go to Discount-Equipment.com to order your parts

HONDA GX160UT2SMXE ENGINE — DECALS ASSY.

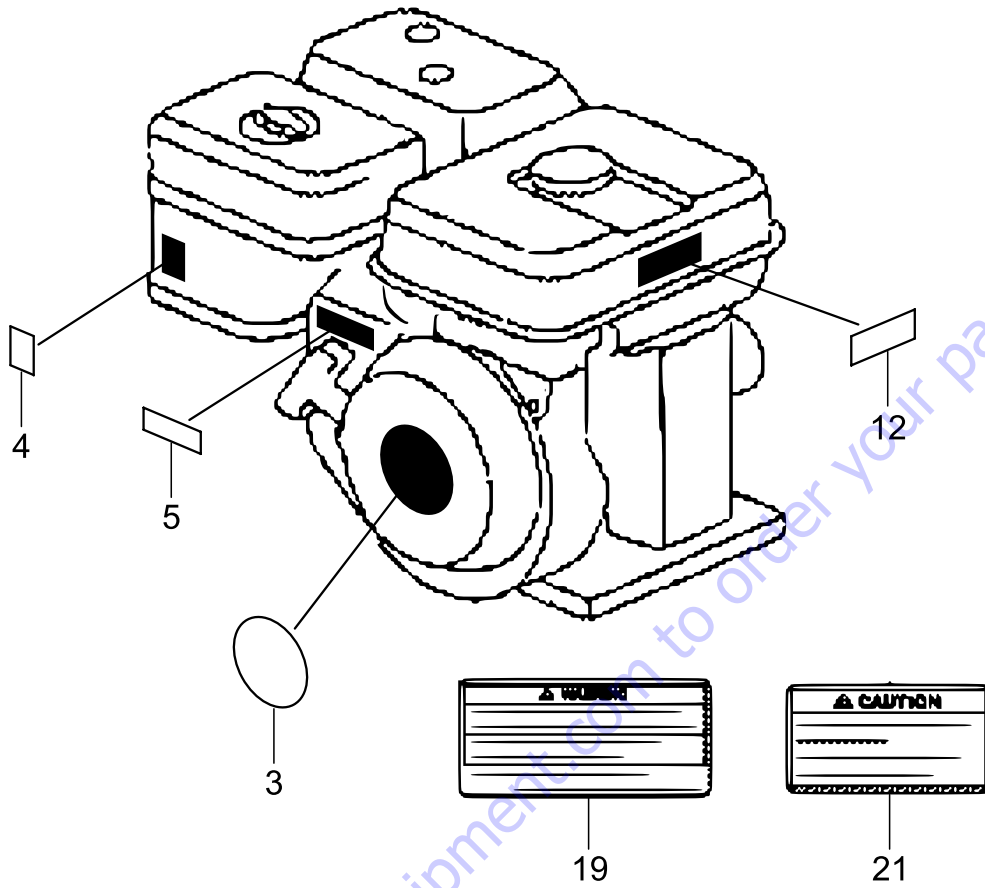

HONDA GX160UT2SMXE ENGINE — DECALS ASSY.

<u>NO.</u>	<u>PART NO.</u>	<u>PART NAME</u>	<u>QTY.</u>	<u>REMARKS</u>
3	87521Z4M000	EMBLEM (GX160)	1	
4	87528Z4M000	MARK, CHOKE	1	
5	87532ZH7000	MARK, THROTTLE INDICATION	1	
12	87519Z4H000	MARK, OP CAUTION (ENGLISH)	1	
19	87516Z4H010	MARK, EX. CAUTION (ENGLISH)	1	
21	87539Z4M000	MARK, EX. CAUTION	1	

Go to Discount-Equipment.com to order your parts

PARTS FINDER

**Search Website
by Part Number**



**Search Manual
Library For Parts
Manual & Lookup Part
Numbers – Purchase
or Request Quote**

Search Manuals

Enter your information to search for manuals and parts.

* Brand:

* Model:

* Serial:

* Part Number:

SEARCH

**Can't Find Part or
Manual? Request Help
by Manufacturer,
Model & Description**

Parts Order Form

Please fill in the following information:

Manufacturer:	<input type="text"/>
Model:	<input type="text"/>
Description:	<input type="text"/>
Part Number:	<input type="text"/>
Quantity:	<input type="text"/>
Notes:	<input type="text"/>

Discount-Equipment.com is your online resource for quality parts & equipment.

Florida: **561-964-4949** Outside Florida TOLL FREE: **877-690-3101**

Need parts?

Click on this link: <http://www.discount-equipment.com/category/5443-parts/> and choose one of the options to help get the right parts and equipment you are looking for. Please have the machine model and serial number available in order to help us get you the correct parts. If you don't find the part on the website or on one of the online manuals, please fill out the request form and one of our experienced staff members will get back to you with a quote for the right part that your machine needs.

We sell worldwide for the brands: Genie, Terex, JLG, MultiQuip, Mikasa, Essick, Whiteman, Mayco, Toro Stone, Diamond Products, Generac Magnum, Airman, Haulotte, Barreto, Power Blanket, Nifty Lift, Atlas Copco, Chicago Pneumatic, Allmand, Miller Curber, Skyjack, Lull, Skytrak, Tsurumi, Husquvarna Target, , Stow, Wacker, Sakai, Mi-T- M, Sullair, Basic, Dynapac, MBW, Weber, Bartell, Bennar Newman, Haulotte, Ditch Runner, Menegotti, Morrison, Contec, Buddy, Crown, Edco, Wyco, Bomag, Laymor, Barreto, EZ Trench, Bil-Jax, F.S. Curtis, Gehl Pavers, Heli, Honda, ICS/PowerGrit, IHI, Partner, Imer, Clipper, MMD, Koshin, Rice, CH&E, General Equipment, ,AMida, Coleman, NAC, Gradall, Square Shooter, Kent, Stanley, Tamco, Toku, Hatz, Kohler, Robin, Wisconsin, Northrock, Oztec, Toker TK, Rol-Air, Small Line, Wanco, Yanmar