

OPERATION AND PARTS MANUAL



www.Discount-Equipment.com

MODEL MGX Series CONCRETE VIBRATOR

Revision #0 (03/26/12)

THIS MANUAL MUST ACCOMPANY THE EQUIPMENT AT ALL TIMES.

PARTS FINDER

**Search Website
by Part Number**



**Search Manual
Library For Parts
Manual & Lookup Part
Numbers – Purchase
or Request Quote**

Search Manuals

Enter your information to help us find the right parts manual for your machine.

* Brand:

* Model:

* Serial:

* Part Number:

SEARCH

**Can't Find Part or
Manual? Request Help
by Manufacturer,
Model & Description**

Parts Order Form

Please fill in the following information to help us find the right part for your machine.

Manufacturer:	<input type="text"/>
Model:	<input type="text"/>
Description:	<input type="text"/>
Part Number:	<input type="text"/>
Quantity:	<input type="text"/>
Notes:	<input type="text"/>

Submit

Discount-Equipment.com is your online resource for quality parts & equipment.

Florida: **561-964-4949** Outside Florida TOLL FREE: **877-690-3101**

Need parts?

Click on this link: <http://www.discount-equipment.com/category/5443-parts/> and choose one of the options to help get the right parts and equipment you are looking for. Please have the machine model and serial number available in order to help us get you the correct parts. If you don't find the part on the website or on one of the online manuals, please fill out the request form and one of our experienced staff members will get back to you with a quote for the right part that your machine needs.

We sell worldwide for the brands: Genie, Terex, JLG, MultiQuip, Mikasa, Essick, Whiteman, Mayco, Toro Stone, Diamond Products, Generac Magnum, Airman, Haulotte, Barreto, Power Blanket, Nifty Lift, Atlas Copco, Chicago Pneumatic, Allmand, Miller Curber, Skyjack, Lull, Skytrak, Tsurumi, Husquvarna Target, Stow, Wacker, Sakai, Mi-T-M, Sullair, Basic, Dynapac, MBW, Weber, Bartell, Bennar Newman, Haulotte, Ditch Runner, Menegotti, Morrison, Contec, Buddy, Crown, Edco, Wyco, Bomag, Laymor, EZ Trench, Bil-Jax, F.S. Curtis, Gehl Pavers, Heli, Honda, ICS/PowerGrit, IHI, Partner, Imer, Clipper, MMD, Koshin, Rice, CH&E, General Equipment, Amida, Coleman, NAC, Gradall, Square Shooter, Kent, Stanley, Tamco, Toku, Hatz, Kohler, Robin, Wisconsin, Northrock, Oztec, Toker TK, Rol-Air, APT, Wylie, Ingersoll Rand / Doosan, Innovatech, Con X, Ammann, Mecalac, Makinex, Smith Surface Prep, Small Line, Wanco, Yanmar

SILICOSIS/RESPIRATORY WARNINGS

⚠ WARNING



SILICOSIS WARNING

Grinding/cutting/drilling of masonry, concrete, metal and other materials with silica in their composition may give off dust or mists containing crystalline silica. Silica is a basic component of sand, quartz, brick clay, granite and numerous other minerals and rocks. Repeated and/or substantial inhalation of airborne crystalline silica can cause serious or fatal respiratory diseases, including silicosis. In addition, California and some other authorities have listed respirable crystalline silica as a substance known to cause cancer. When cutting such materials, always follow the respiratory precautions mentioned above.

⚠ WARNING

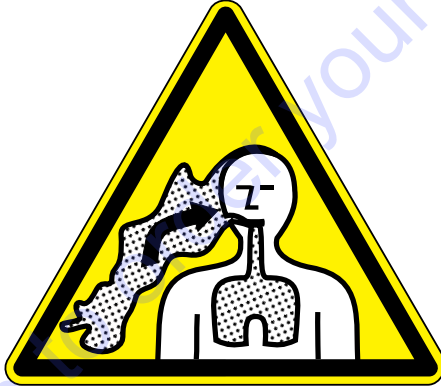

RESPIRATORY HAZARDS

Grinding/cutting/drilling of masonry, concrete, metal and other materials can generate dust, mists and fumes containing chemicals known to cause serious or fatal injury or illness, such as respiratory disease, cancer, birth defects or other reproductive harm. If you are unfamiliar with the risks associated with the particular process and/or material being cut or the composition of the tool being used, review the material safety data sheet and/or consult your employer, the material manufacturer/supplier, governmental agencies such as OSHA and NIOSH and other sources on hazardous materials. California and some other authorities, for instance, have published lists of substances known to cause cancer, reproductive toxicity, or other harmful effects.

Control dust, mist and fumes at the source where possible. In this regard use good work practices and follow the recommendations of the manufacturers or suppliers, OSHA/NIOSH, and occupational and trade associations. Water should be used for dust suppression when wet cutting is feasible. When the hazards from inhalation of dust, mists and fumes cannot be eliminated, the operator and any bystanders should always wear a respirator approved by NIOSH/MSHA for the materials being used.

TABLE OF CONTENTS

MGX Series Concrete Vibrator

Silicosis/Respiratory Warnings	3
Table Of Contents	4
Parts Ordering Procedures	5
Safety Information	6-9
Specifications	10
Dimensions	11
General Information	12-13
Components	14
Operation	15
Maintenance	16-18
Troubleshooting	19
Explanation Of Code In Remarks Column	20
Suggested Spare Parts	21

Component Drawings

Motor Assy.	22-23
Shaft/Head Assy.	24-27
Terms And Conditions Of Sale — Parts	28

NOTICE

Specifications and part numbers are subject to change without notice.

SAFETY INFORMATION

DO NOT operate or service the equipment before reading the entire manual. Safety precautions should be followed at all times when operating this equipment. Failure to read and understand the safety messages and operating instructions could result in injury to yourself and others.



SAFETY MESSAGES

The four safety messages shown below will inform you about potential hazards that could injure you or others. The safety messages specifically address the level of exposure to the operator and are preceded by one of four words: **DANGER**, **WARNING**, **CAUTION** or **NOTICE**.

SAFETY SYMBOLS

! DANGER

Indicates a hazardous situation which, if not avoided, **WILL** result in **DEATH** or **SERIOUS INJURY**.

! WARNING

Indicates a hazardous situation which, if not avoided, **COULD** result in **DEATH** or **SERIOUS INJURY**.

! CAUTION

Indicates a hazardous situation which, if not avoided, **COULD** result in **MINOR** or **MODERATE INJURY**.

NOTICE

Addresses practices not related to personal injury.

Potential hazards associated with the operation of this equipment will be referenced with hazard symbols which may appear throughout this manual in conjunction with safety messages.

Symbol	Safety Hazard
	Burn hazards
	Electric shock hazards

PERSONAL SAFETY

! CAUTION

- Stay alert, watch what you are doing and use common sense when operating a power tool. Do not use a power tool while you are tired or under the influence of drugs, alcohol or medication. A moment of inattention while operating power tools may result in serious personal injury.



- Use personal protective equipment. Always wear eye protection. Protective equipment such as dust mask, non-skid safety shoes, hard hat, or hearing protection used for appropriate conditions will reduce personal injuries..



- Prevent unintentional starting. Ensure the switch is in the off position before connecting to power source, picking up or carrying the tool. Carrying power tools with your finger on the switch or energizing power tools that have the switch on can cause accidents.

- Remove any adjusting key or wrench before turning the power tool on. A wrench or a key left attached to a rotating part of the power tool may result in personal injury.

- DO NOT** overreach. Keep proper footing and balance at all times. This enables better control of the power tool in unexpected situations.

- Dress properly. Do not wear loose clothing or jewelry. Keep your hair, clothing and gloves away from moving parts. Loose clothes, jewelry or long hair can be caught in moving parts.

- If devices are provided for the connection of dust extraction and collection facilities, ensure these are connected and properly used. Use of dust collection can reduce dust-related hazards.

SAFETY INFORMATION

GENERAL POWER TOOL SAFETY WARNINGS

WARNING

- Read all safety warnings and all instructions. Failure to follow the warnings and instructions may result in electric shock, fire and/or serious injury.
- Save all warnings and instructions for future reference.



NOTICE

- The term "power tool" in the warnings refers to your mains-operated (corded) power tool.

WORK AREA SAFETY

NOTICE

- Keep work area clean and well lit. Cluttered or dark areas invite accidents.
- **DO NOT** operate power tools in **explosive atmospheres**, such as in the presence of flammable liquids, gases or dust. Power tools create sparks which may ignite the dust or fumes.
- Keep children and bystanders away while operating a power tool. Distractions can cause you to lose control.
- **ALWAYS** clear the work area of any debris, tools, etc. that would constitute a hazard while the equipment is in operation.
- No one other than the operator is to be in the working area when the equipment is in operation.
- **DO NOT** use the equipment for any purpose other than its intended purpose or application.
- This equipment should only be operated by trained and qualified personnel, 18 years of age and older.
- Whenever necessary, replace nameplate, operation and safety decals when they become difficult read.
- Manufacturer does not assume responsibility for any accident due to equipment modifications. Unauthorized equipment modification will void all warranties.

- **NEVER** use accessories or attachments that are not recommended by Multiquip for this equipment. Damage to the equipment and/or injury to user may result.

- **ALWAYS** know the location of the nearest **fire extinguisher**.



- **ALWAYS** know the location of the nearest **first aid kit**.



- **ALWAYS** know the location of the nearest phone or **keep a phone on the job site**. Also, know the phone numbers of the nearest **ambulance, doctor and fire department**. This information will be invaluable in the case of an emergency.



MOTOR AND FLEXSHAFT SAFETY

DANGER

- **ALWAYS** wear rubber insulated gloves and boots when holding the flexshaft during operation. The possibility of electrocution exists causing equipment damage and severe bodily harm even death!

DANGER

- If applicable, periodically check insulation resistance. The possibility of electrocution exists causing equipment damage and severe bodily harm even death!

WARNING

- **NEVER** attempt to run the core outside the casing assembly for any reason.

CAUTION

- **DO NOT** carry plugged-in motor with finger on the switch.
- **NEVER** carry the motor by the cord. Use the carrying handle.
- **ALWAYS** check the vibrator motor for loosened hardware such as nuts and bolts before starting.
- Keep the cord from heat, oil, and sharp objects.
- **DO NOT** overload the motor. It will do a better and safer job at the rate for which it was designed.

SAFETY INFORMATION

- **DO NOT** expose vibrator motor to rain.
- **DO NOT** use vibrator motor in damp or wet locations without proper electrical circuits.
- **DO NOT** immerse the motor part in concrete.
- **ALWAYS** keep clear of rotating or moving parts while operating the vibrator motor.
- **NEVER** leave the machine unattended while running.
- **ALWAYS** disconnect the motor from the power source when not in use, before servicing, and when changing flexible shafting and vibrator heads.
- Allow the vibrator motor to cool before servicing. Contact with hot components can cause serious burns.
- Before each use, **ALWAYS** check the motor to make certain that there are no damaged parts and that all parts function properly (such as switch, cord housing). If any damage or malfunctioning parts are found, have them repaired or replaced by an authorized service facility.



NOTICE

- Secure forms. Make sure the form work is well made and braced to withstand the stresses made by vibration.
- Keep vibrator motor clean for better and safer operation.
- **ALWAYS** store equipment properly when it is not being used. Equipment should be stored in a clean, dry location out of the reach of children and unauthorized personnel.
- Use only factory-authorized replacement parts.
- Store idle vibrator motor. When not in use, motor should be stored in a dry, safe storage area.

ELECTRICAL SAFETY

⚠ CAUTION

- Power tools must match the outlet. **NEVER** modify the plug in any way. **DO NOT** use any adapter plugs with earthed (grounded) power tools. Unmodified plugs and matching outlets will reduce risk of electric shock.
- Avoid body contact with earthed or grounded surfaces such as pipes, radiators, ranges and refrigerators. There is an increased risk of electric shock if your body is earthed or grounded.
- **DO NOT** expose power tools to rain or wet conditions. Water entering a power tool will increase the risk of electric shock.
- **DO NOT** abuse power cord. **NEVER** use the cord for carrying, pulling or unplugging the power tool. Keep cord away from heat, oil sharp edges or moving parts. Damaged or entangled cords increase the risk of electric shock.
- When operating a power tool outdoors, use an extension cord suitable for outdoor use. Use of a cord suitable for outdoor use reduces the risk of electric shock.
- This unit is double-insulated. The double-insulation between the electric-conducting part and the outside frame makes grounding unnecessary. However, if parts are replaced with wrong parts or assembled incorrectly, the vibrator may become unsafe to operate. Use only Multiquip recommended replacement parts.
- When applicable, use a protection wiring device, such as a Ground Fault Circuit Interrupter, for the protection of personnel.
- Operate electric motor only at the specified voltage indicated on the nameplate.
- **DO NOT** spray water onto electric motor.
- **DO NOT** yank the cord to disconnect it from the receptacle. Grasp the plug itself to disconnect it.
- **ALWAYS** make sure the ON/OFF switch on the electric motor is in the OFF position when not in use and before inserting the power plug into an AC receptacle.
- Before plugging the motor into a power source, **ALWAYS** remove any wrenches or other tools from the motor, shaft, and head that were used for assembly.

SAFETY INFORMATION

Power Cord/Cable Safety

DANGER

- **ALWAYS** use a grounded 3-wire extension cord that has a 3-prong grounding plug, and a 3-pole receptacle that accepts the plug on the concrete vibrator motor. **DO NOT REMOVE THE GROUNDING PIN FROM THE PLUG!**
- **NEVER** let power cords or cables lay in water.
- **NEVER** use **damaged** or **worn** cables or cords when connecting equipment to generator. Inspect for cuts in the insulation.
- **NEVER** grab or touch a live power cord or cable with wet hands. The possibility exists of **electrical shock, electrocution or death.**
- Make sure power cables are securely connected. Incorrect connections may cause electrical shock and damage to the vibrator motor.

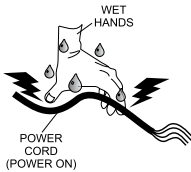

CAUTION

- Ensure that cables and cords will not be tripped over.

NOTICE

- **ALWAYS** make certain that proper power or extension cord has been selected for the job.
- Use only extension cords that are intended for outdoor use and so marked.
- Use only the gauge wire and length of cord recommended for the motor size. If in doubt, go to the next heavier gauge. (The smaller the gauge number, the heavier the cord.)

POWER TOOL USE AND CARE

- **DO NOT** force the power tool. Use the correct power tool for your application. The correct power tool will do the job better and safer at the rate for which it was designed.
- **DO NOT** use the power tool if the switch does not turn it on and off. Any power tool that cannot be controlled with the switch is dangerous and must be repaired.

- Disconnect the plug from the power source and/or the battery pack from the power tool before making any adjustments, changing accessories, or storing power tools. Such preventive safety measures reduce the risk of starting the power tool accidentally.
- Store idle power tools out of the reach of children and do not allow persons unfamiliar with the power tool or these instructions to operate the power tool. Power tools are dangerous in the hands of untrained users.
- Maintain power tools. Check for misalignment or binding of moving parts, breakage of parts and any other condition that may affect the power tool's operation. If damaged, have the power tool repaired before use. Many accidents are caused by poorly maintained power tools.
- Keep cutting tools sharp and clean. Properly maintained cutting tools with sharp cutting edges are less likely to bind and are easier to control.
- Use the power tool, accessories and tool bits etc. in accordance with these instructions, taking into account the working conditions and the work to be performed. Use of the power tool for operations different from those intended could result in a hazardous situation.

SERVICE

- Have your power tool serviced by a qualified repair person using only identical replacement parts. This will ensure that the safety of the power tool is maintained.

ENVIRONMENTAL SAFETY/DECOMMISSIONING

NOTICE

- **DO NOT** pour waste or oil directly onto the ground, down a drain or into any water source.
- Contact your country's Department of Public Works or recycling agency in your area and arrange for proper disposal of any electrical components, waste or oil associated with this equipment.
- When the life-cycle of this equipment is over it is recommended that the head casing and all other metal parts be sent to a recycling center.



SPECIFICATIONS

Table 1. Vibrator Specifications

120 Volt Models	240 Volt Models	Amps 120V (240V)	Watts	Head in. (mm)	Shaft Dia in. (mm)	Amplitude in. (mm)	Frequency Hz (rpm)	Shaft Length ft. (m)	Overall Length ft. (m)	Motor Weight lb. (kg)	Shaft/Head Weight lb. (kg)	Total Weight lb. (kg)
MGX12325	MGX22325	3.8 (2.1)	280	.905 (23)	.79 (20)	.047 (1.2)	12,000 to 15,500 (200 to 258)	8.2 (2.5)	9.5 (2.9)	6.4 (2.9)	5.07 (2.3)	11.5 (5.2)
MGX12810	MGX22810	3.8 (2.1)	280	1.10 (28)	.98 (25)	.070 (1.8)	12,000 to 15,500 (200 to 258)	3.2 (1.0)	4.7 (1.4)	6.4 (2.9)	3.08 (1.4)	9.5 (4.3)
MGX12825	MGX22825	3.8 (2.1)	280	1.10 (28)	.98 (25)	.070 (1.8)	12,000 to 15,500 (200 to 258)	8.2 (2.5)	9.5 (2.9)	6.4 (2.9)	5.07 (2.3)	11.5 (5.2)
MGX13225	MGX23225	3.8 (2.1)	280	1.25 (32)	.98 (25)	.075 (1.9)	12,000 to 15,500 (200 to 258)	8.2 (2.5)	9.5 (2.9)	6.4 (2.9)	3.08 (1.4)	9.5 (4.3)
MGX13810	MGX23810	3.8 (2.1)	280	1.5 (38)	.98 (25)	.079 (2.0)	12,000 to 15,500 (200 to 258)	3.2 (1.0)	4.7 (1.4)	6.4 (2.9)	5.07 (2.3)	11.5 (5.2)
MGX13825	MGX23825	3.8 (2.1)	280	1.5 (38)	.98 (25)	.079 (2.0)	12,000 to 15,500 (200 to 258)	8.2 (2.5)	9.5 (2.9)	6.4 (2.9)	3.08 (1.4)	9.5 (4.3)

Table 2. Replacement Heads and Shafts Specifications

Head/Shaft Model	Head Diameter in. (mm)	Shaft Length ft (m)
MGX2325	.9 (23)	8.2 (2.5)
MGX2810	1.10 (28)	3.2 (1.0)
MGX2825	1.10 (28)	8.2 (2.5)
MGX3225	1.25 (32)	8.2 (2.5)
MGX3810	1.5 (38)	3.2 (1.0)
MGX3825	1.5 (38)	8.2 (2.5)

DIMENSIONS

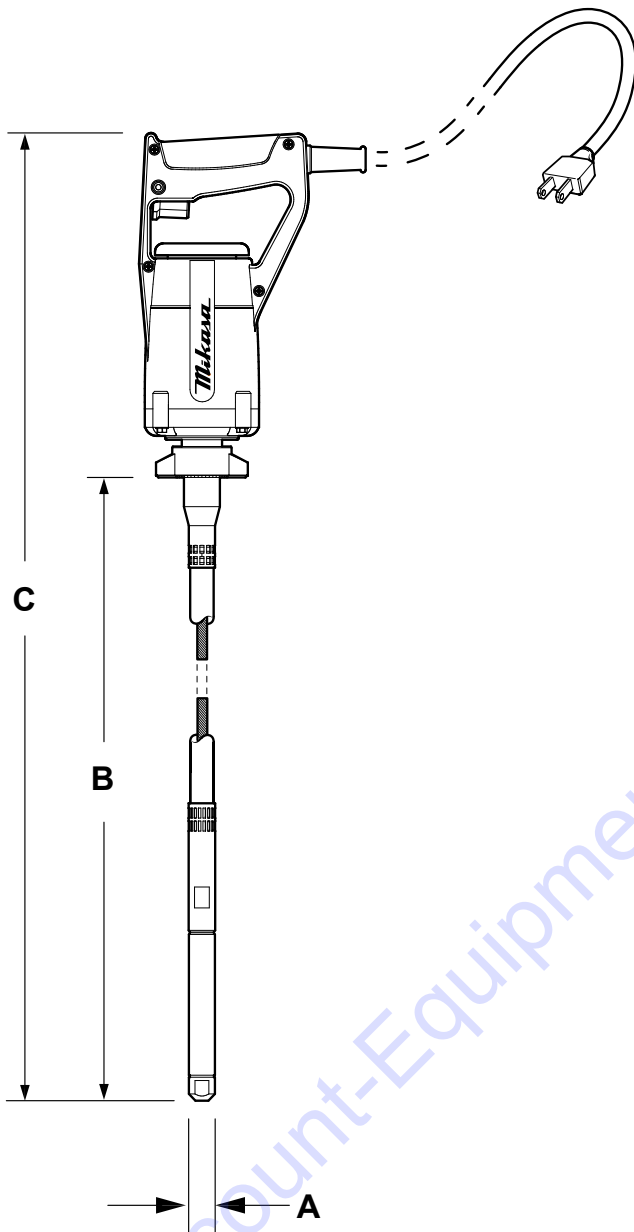

Table 3. Dimensions				
120 Volt Models	240 Volt Models	Head (A) in. (mm)	Shaft Length (B) ft. (m)	Overall Length (C) ft. (m)
MGX12325	MGX22325	.905 (23)	8.2 (2.5)	9.5 (2.9)
MGX12810	MGX22810	1.10 (28)	3.2 (1.0)	4.7 (1.4)
MGX12825	MGX22825	1.10 (28)	8.2 (2.5)	9.5 (2.9)
MGX13225	MGX23225	1.25 (32)	8.2 (2.5)	9.5 (2.9)
MGX13810	MGX23810	1.5 (38)	3.2 (1.0)	4.7 (1.4)
MGX13825	MGX23825	1.5 (38)	8.2 (2.5)	9.5 (2.9)

Figure 1. MGX Vibrator Dimensions

GENERAL INFORMATION

The MGX Vibrator has a double-insulated motor (no ground necessary) with advanced and user-friendly design. The motor is lightweight and durable with an aluminum motor case. The frontend closed-motor design prevents any invasion of mortar and foreign material from the front.

Vibration-dampening handle grip reduces operator fatigue.

Original cord protector gives flexibility to input cord for longer cord life.

Multiquip's shaft/heads are designed to work in medium to high slump concrete. Typical applications include small pours, slabs driveways, stem walls and footings.

A vibrating steel head is attached to one end of the flexshaft. This head generates vibration via an eccentric rotator that consolidates the concrete by removing air pockets. The round head design allows for the transmission of vibration in all directions.

WHY VIBRATE CONCRETE

To ensure optimum strength and durability, vibration of fresh concrete is an important requirement. Vibration or compaction is the principal method for consolidation of concrete.

CONSOLIDATION

Consolidation eliminates pockets of aggregate and air bubbles maximizing strength, eliminating surface voids. Vibrators consolidate concrete by transmitting shock waves which allow the aggregate to float freely while pushing lighter trapped air up and out of the concrete mix.

A properly consolidated concrete pour will display a thin line of mortar appearing along the form near the vibrator and the coarse aggregate has been dispersed evenly throughout the pour and is not visible.

VIBRATION TIME

Vibration time depends on frequency. The higher the frequency, the less vibration time is required for the job.

VIBRATION RANGE

Vibration range (Figure 2) can be defined as "Area of Influence". This area of influence (vibrating radius) is the distance from the center of the vibrator to the outer most edge.

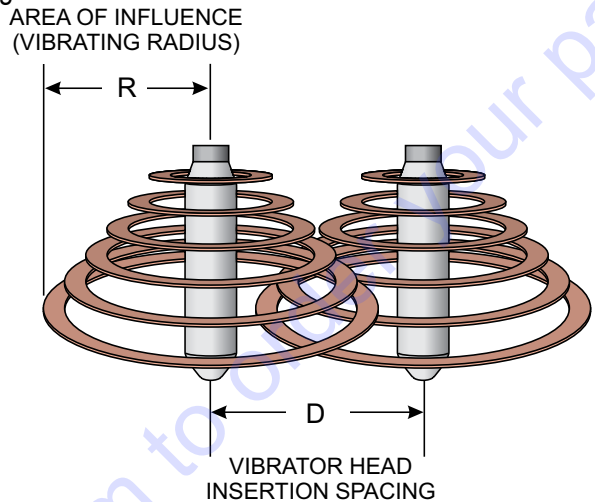

Figure 2. Vibrator Radius/Spacing

Table 4 shows the vibration radius and spacing for a given vibrator head diameter.

120 Volt Models	240 Volt Models	HeadDia. in. (mm)#	Vibration Radius (R) in. (mm)	Vibrator Spacing (D) in. (mm)
MGX12325	MGX22325	.9 (23)	4 (102)	6 (152)
MGX12810	MGX22810	1.1 (28)	5.5 (140)	8.25 (210)
MGX12825	MGX22825	1.1 (28)	5.5 (140)	8.25 (210)
MGX13225	MGX23225	1.25 (32)	8 (203)	12 (305)
MGX13810	MGX23810	1.5 (38)	12 (305)	18 (427)
MGX13825	MGX23825	1.5 (38)	12 (305)	18 (427)

NOTICE

Radius (area of influence **R**) and vibrator head spacing (**D**) are expressed in inches/millimeters. Radius and distance values expressed in Table 4 are only to be used as a general guide. Values are subject to change.

GENERAL INFORMATION

NOTICE

Vibrator head spacing distance (**D**) is calculated by multiplying the vibrating head radius (**R**) (area of influence) by 1.5.

When determining which head to choose it is important to access the application. Mainly what are the dimensions of the application. Select the vibrator head based on its radiating radius characteristics. Reference Table 4.

Select the vibrating head that covers the largest possible area without excessive overkill. This will allow for more efficient productivity. General rule of thumb is **DO NOT** select a vibrator head which has a vibration radius of more than twice the width of the form.

Example:

If the form width is 9 inches (229 mm) the selected vibrator head radius should not exceed an 18 inch (457 mm) radius.

In this example the MGX3810 and MGX3825 head/shaft would be the recommended choice. Refer to Table 4 and Figure 3.

NOTICE

Vibration techniques, vibrator head placement and spacing as referenced in the "General Information" and "Operation" sections of this manual is only to be **used as a guideline**. Multiquip assumes no responsibility for vibrator operating techniques referenced in this manual.

The consolidation of concrete has many mitigating factors that must be considered such as slump, mix, depth of vibrator, vibrator spacing, vibration time, vibration frequency, temperature. All of these factors must be considered when the consolidation (vibration) of concrete is required.

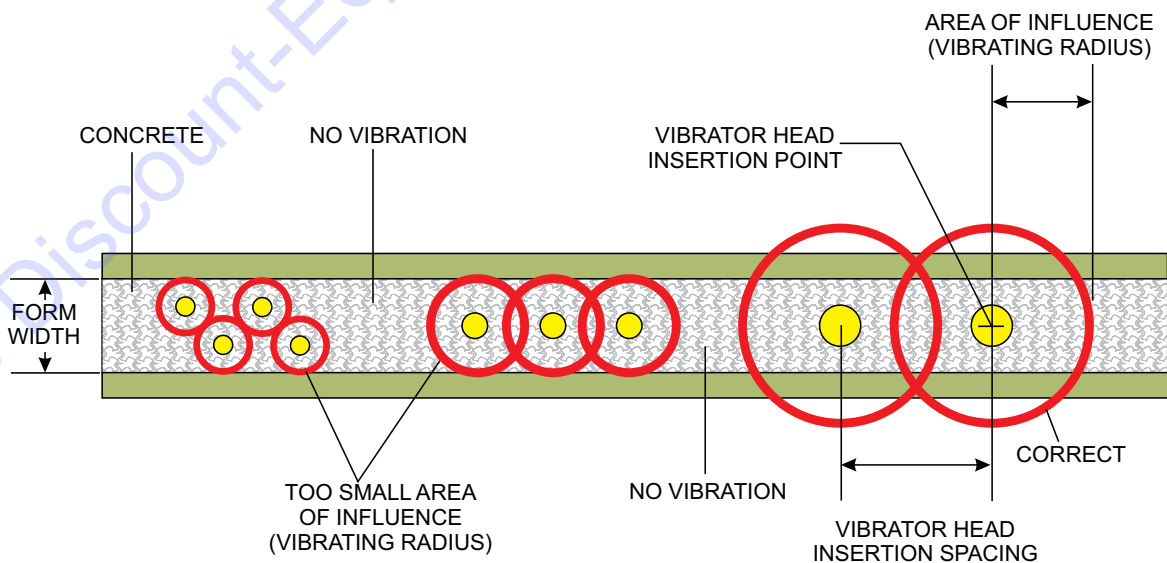

Figure 3. Head Selection

COMPONENTS

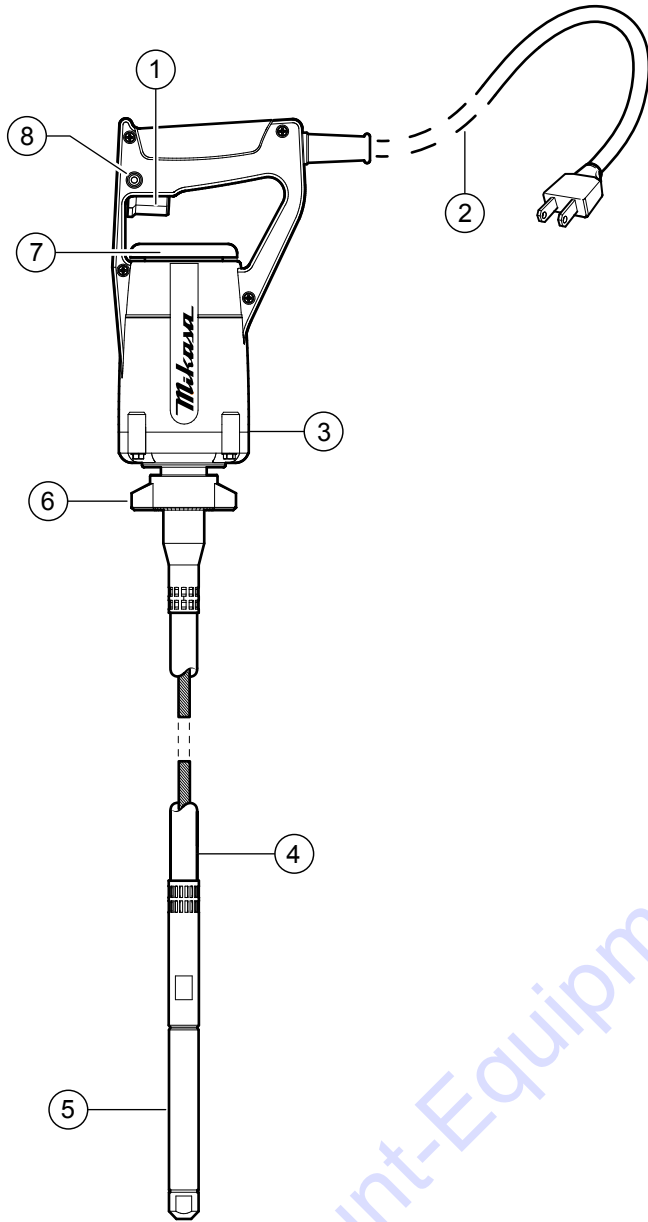

Figure 4. MGX Vibrator Components

1. **ON/OFF Switch** — Turns power on when pressed and off when released.
2. **Power Cord** — Connects to the power source. (120V or 220V depending on model). Make sure to check voltage on motor nameplate and connect to the appropriate power source.
3. **Motor** — 120V or 240V depending on model.
4. **Flexible Shaft** — Transmits rotary motion from the motor to the head.
5. **Vibrator Head** — Generates vibration via an eccentric rotator that consolidates the concrete by removing air pockets.
6. **Coupler** — Attaches the shaft/head assembly to the motor.
7. **Air Intake** — Air comes in and suctioned by the fan to cool the motor, then discharged at the rear of the motor.
8. **Power Lock Button** — Locks the **ON/OFF Switch** to the ON position. Lock is released when the **ON/OFF Switch** is pressed again.

OPERATION

1. Connect the vibrator to the proper power source.
2. If an extension cord is necessary, refer to Table 5 for the correct type of extension cord to use.

Table 5. Extension Cord Types

Current in Amperes	Load in Watts		Maximum Allowable Cable Length			
	At 100 Volts	At 200 Volts	#10 Wire	#12 Wire	#14 Wire	#16 Wire
2.5	300	600	1000 ft.	600 ft.	375 ft.	250 ft.
5	600	1200	500 ft.	300 ft.	200 ft.	125 ft.
7.5	900	1800	350 ft.	200 ft.	125 ft.	100 ft.
10	1200	2400	250 ft.	150 ft.	100 ft.	
15	1800	3600	150 ft.	100 ft.	65 ft.	
20	2400	4800	125 ft.	75 ft.	50 ft.	

3. Hold vibrator head above concrete pour when starting drive motor. This will prevent the vibrator head from bouncing on hard surfaces which could damage the bearings.
4. Push the ON/OFF switch to the ON position then immerse into the surface. Do not run the motor outside of the surface for long periods.

NOTICE

Pressing the Power Lock Button will lock the On/OFF switch to the ON position.

5. Keep flexshaft (Figure 5) straight as possible when operating. Sharp bends increase the load on the core and drive motor, which will result in early core failure and possible damage to the drive motor.

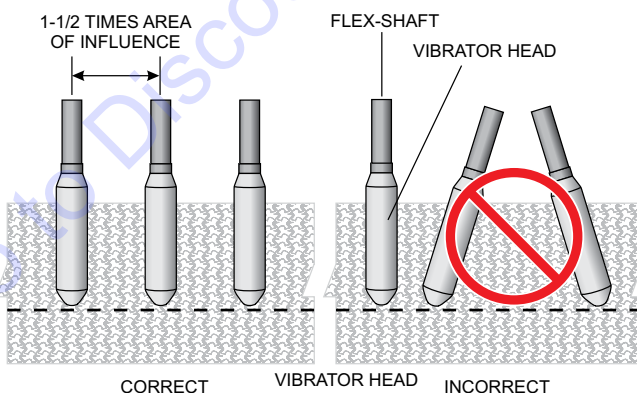

Figure 5. Vibrator Head Insertion

6. Completely immerse the vibrator head quickly into the concrete mix at a verticle rate of about one foot per second (0.3 meters/second). Vibrate concrete for about 5 to 15 seconds for wet mixes. For stiff mixes vibrate 2-3 minutes.
7. Stop vibration of concrete mix when concrete has a level, glossy surface and there are no breaking air bubbles.
8. Slowly lift the head out of the mix using an up and down movement. This slight up and down movement will close the hole formed by the vibrator.
9. When lifting the head out of the concrete, withdraw slowly at a rate of about 3 sec./ft. Using this technique will avoid the re-trapping of air.
10. When near the top of the mix, withdraw the vibrator quickly.
11. Re-insert vibrator into mix according to the "area of influence" See Figure 5. Establish a symmetrical overlapping pattern for inserting and removing the vibrator head.
12. If concrete is poured in layers, allow vibrator to pass within 3 to 6 inches (76 to 152 mm.) into next layer to ensure the knitting of the two layers. The complete bonding of layers will prevent "lift lines" when forms are removed.

NOTICE

DO NOT use vibrator to move concrete laterally. This will cause segregation of the concrete. Use a shovel or similar device to spread the concrete.

MAINTENANCE

DRIVE MOTOR INSPECTION

1. Visually inspect the motor daily before use for defective or missing parts, and have repairs made before use.

CARBON BRUSH REPLACEMENT

1. To gain access to the carbon brushes, remove the body cover from the motor (see Figure 6).

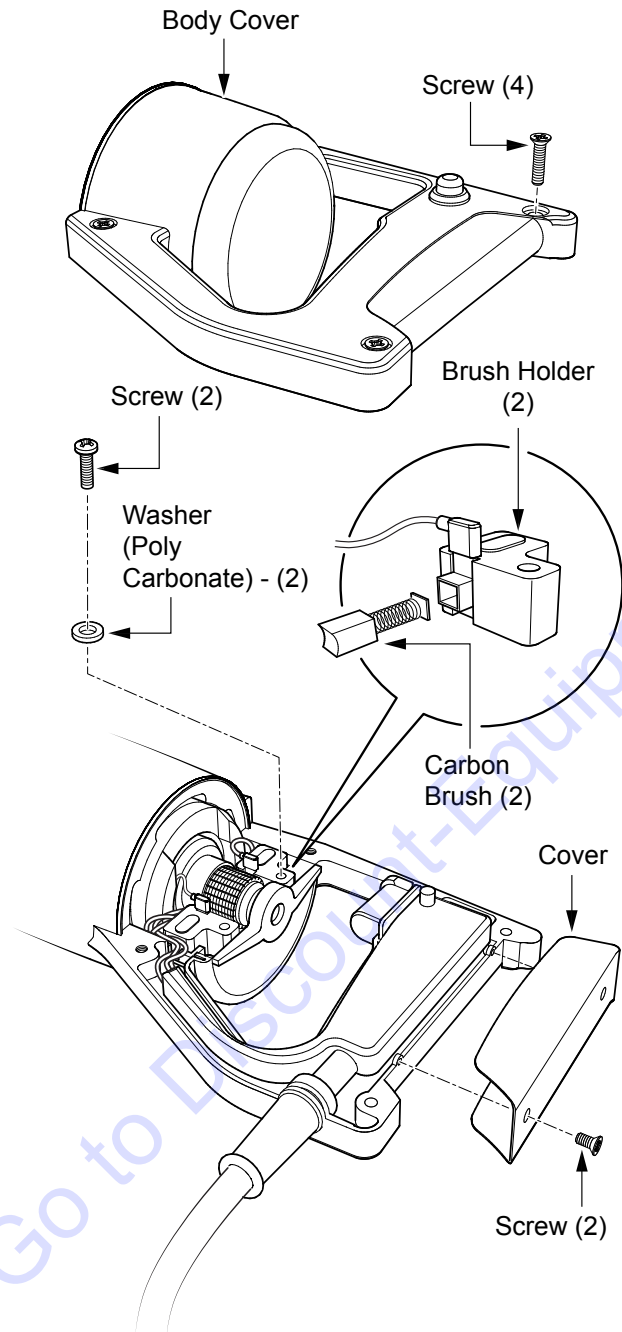

Figure 6. Carbon Brush Replacement

2. Remove the screw and washer securing the brush holder.
3. Inspect the brush and replace when they become worn to a length of 3/8".

VIBRATOR HEAD LUBRICATION (300 HOURS)

1. Using a wrench, remove vibrator head tip (Figure 7) from vibrator head body. Have a cloth handy to catch any spilled oil.

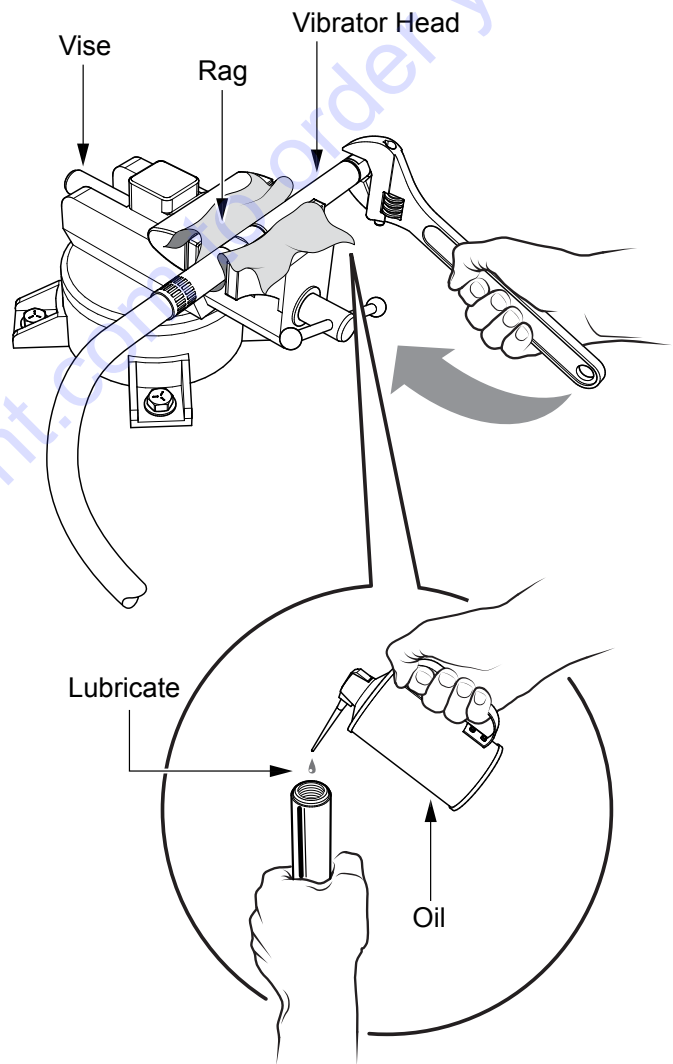

Figure 7. Adding Oil (Vibrator Head)

2. Drain old oil from vibrator head body (casing). Place oil in a suitable container. **DO NOT** pour oil on the ground.

NOTICE

Dispose used vibrator head oil in accordance with city, local and state environmental guidelines.

- Fill vibrator head body with SAE 15 or AW MV ISO 46 type oil or equivalent.
- DO NOT** fill head body beyond capacity. Reference Table 6.

NOTICE

DO NOT overfill. Too much oil in the vibrator head will overload the drive motor.

Table 6. Vibrator Head Oil Capacity

120 Volt Models	240 Volt Models	Oil Capacity. oz. (ml)#
MGX12325	MGX22325	2.4 (70)
MGX12810	MGX22810	0.5 (15)
MGX12825	MGX22825	2.4 (70)
MGX13225	MGX23225	2.4 (70)
MGX13810	MGX23810	0.5 (15)
MGX13825	MGX23825	2.4 (70)

VIBRATOR HEAD WEAR (300 HOURS)

- Periodically measure the outside diameter (Figure 8) of the vibrator head casing.

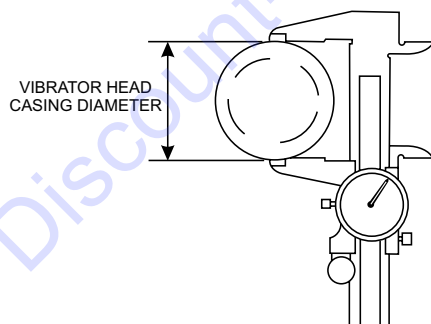

Figure 8. Vibrator Head Diameter

- Replace vibrator shaft/head assembly if head diameter is at maximum wear as specified in Table 7. See Table 2 for available models and specifications. Shaft/head assemblies should be replaced by a qualified technician.

Table 7. Vibrator Head Wear Diameter

120 Volt Models	240 Volt Models	New Head Dia. in. (mm)#	Head Dia. w/ Max Wear in. (mm)
MGX12325	MGX22325	.905 (23)	.842 (21.39)
MGX12810	MGX22810	1.1 (28)	1.02 (25.91)
MGX12825	MGX22825	1.1 (28)	1.02 (25.91)
MGX13225	MGX23225	1.25 (32)	1.16 (29.46)
MGX13810	MGX23810	1.5 (38)	1.39 (35.31)
MGX13825	MGX23825	1.5 (38)	1.39 (35.31)

SHAFT LUBRICATION (200 HOURS)

- Place the vibrator on a suitable workbench. Make sure the area is clear of clutter.
- Turn the plastic coupler holding the shaft to the motor clockwise until completely loose (Figure 9). If the coupler does not come off easily, place motor in a vise and hit the coupler with a rubber mallet to loosen.

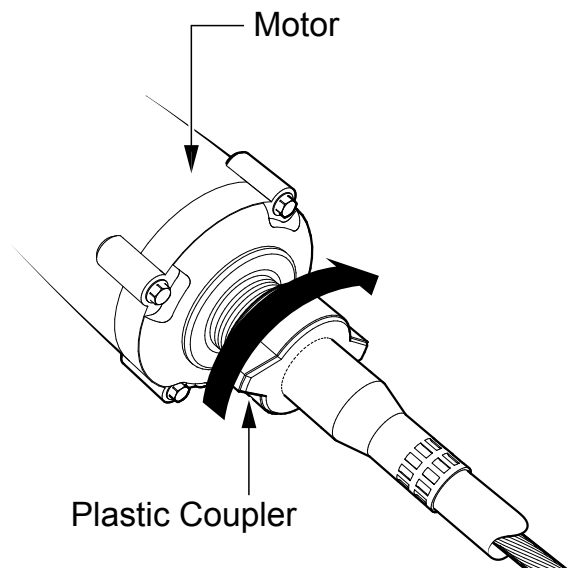

Figure 9. Loosening Shaft Coupler

- Gently pull out flexible shaft collar to access the flex shaft core crimp. See Figure 10.

4. Place a 5/16-inch wrench on the flat side of the motor shaft coupling.
5. Using a pair of pliers, grip the flex shaft core crimp.
6. Turn the motor coupling clockwise with the wrench to remove shaft from motor.

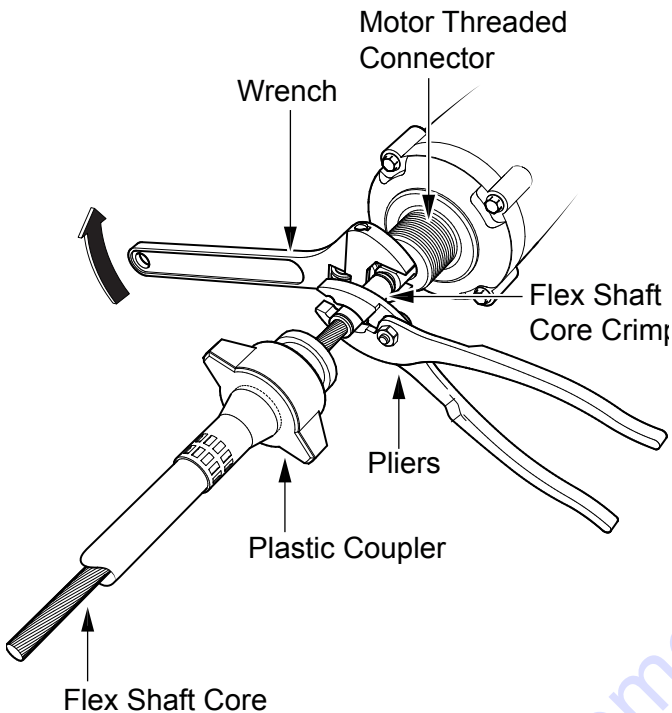

Figure 10. Removing Shaft from Motor

7. Slowly pull the wire core from the shaft.
8. Inspect the core for broken wires, permanent set or other damage such as an area that indicates high wear or having overheated. If any of these conditions exist, replace shaft/head assembly.
9. Use the core to push a cleaning patch through the casing to remove any old grease or foreign matter that may have accumulated inside the casing.

NOTICE

DO NOT use solvents to clean casing. Applying solvents to the core or casing may cause grease (lubricant) to breakdown, resulting in damage to the shaft.

10. Thoroughly clean wire core (Figure 11) if it is being reused. A wire brush may be required to remove hardened residue.

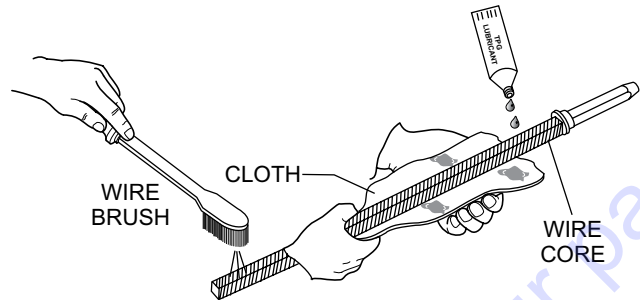

Figure 11. Cleaning Wire Core

11. Apply a light amount of DuBois "TPG" lubricant (Figure 11) or a good grade bearing grease to the entire length of the wire core.

NOTICE

DO NOT force casing full of grease. A tightly packed casing will load the drive motor which could lead to overheating.

12. Reinstall wire core back into casing.
13. Align the flexible shaft core to the motor shaft.
14. Using a pair of pliers, grip the flex shaft core crimp.
15. Place a 5/16-inch wrench on the flat side of the motor shaft.
16. Turn the motor coupling counterclockwise with the wrench until tight.
17. Align and push the flexible shaft into the motor threaded connector.
18. Tighten the plastic coupler making sure shaft/head assembly is connected securely to the motor.

TROUBLESHOOTING

Table 8. Vibrator Troubleshooting

Symptom	Possible Problem	Solution
Shaft Binding	Shaft kinked?	Straighten out shaft.
	Defective shaft?	Replace shaft/head.
Leaking Vibrator Head	Too much oil in head casing?	Fill head casing to recommended level.
	Head bearings/seals defective?	Replace shaft/head.

Go to Discount-Equipment.com to order your parts

EXPLANATION OF CODE IN REMARKS COLUMN

The following section explains the different symbols and remarks used in the Parts section of this manual. Use the help numbers found on the back page of the manual if there are any questions.

NOTICE

The contents and part numbers listed in the parts section are subject to change **without notice**. Multiquip does not guarantee the availability of the parts listed.

SAMPLE PARTS LIST

NO.	PART NO.	PART NAME	QTY.	REMARKS
1	12345	BOLT	1	INCLUDES ITEMS W/%
2%		WASHER, 1/4 IN.		NOT SOLD SEPARATELY
2%	12347	WASHER, 3/8 IN. ...	1	MQ-45T ONLY
3	12348	HOSE	A/R	MAKE LOCALLY
4	12349	BEARING	1	S/N 2345B AND ABOVE

NO. Column

Unique Symbols — All items with same unique symbol

(@, #, +, %, or >) in the number column belong to the same assembly or kit, which is indicated by a note in the “Remarks” column.

Duplicate Item Numbers — Duplicate numbers indicate multiple part numbers, which are in effect for the same general item, such as different size saw blade guards in use or a part that has been updated on newer versions of the same machine.

NOTICE

When ordering a part that has more than one item number listed, check the remarks column for help in determining the proper part to order.

PART NO. Column

Numbers Used — Part numbers can be indicated by a number, a blank entry, or TBD.

TBD (To Be Determined) is generally used to show a part that has not been assigned a formal part number at the time of publication.

A blank entry generally indicates that the item is not sold separately or is not sold by Multiquip. Other entries will be clarified in the “Remarks” Column.

QTY. Column

Numbers Used — Item quantity can be indicated by a number, a blank entry, or A/R.

A/R (As Required) is generally used for hoses or other parts that are sold in bulk and cut to length.

A blank entry generally indicates that the item is not sold separately. Other entries will be clarified in the “Remarks” Column.

REMARKS Column

Some of the most common notes found in the “Remarks” Column are listed below. Other additional notes needed to describe the item can also be shown.

Assembly/Kit — All items on the parts list with the same unique symbol will be included when this item is purchased.

Indicated by:

“INCLUDES ITEMS W/(unique symbol)”

Serial Number Break — Used to list an effective serial number range where a particular part is used.

Indicated by:

“S/N XXXXX AND BELOW”

“S/N XXXX AND ABOVE”

“S/N XXXX TO S/N XXX”

Specific Model Number Use — Indicates that the part is used only with the specific model number or model number variant listed. It can also be used to show a part is NOT used on a specific model or model number variant.

Indicated by:

“XXXXX ONLY”

“NOT USED ON XXXX”

“Make/Obtain Locally” — Indicates that the part can be purchased at any hardware shop or made out of available items. Examples include battery cables, shims, and certain washers and nuts.

“Not Sold Separately” — Indicates that an item cannot be purchased as a separate item and is either part of an assembly/kit that can be purchased, or is not available for sale through Multiquip.

SUGGESTED SPARE PARTS

MGX SERIES VIBRATORS

1 to 3 units

Qty.	P/N	Description
3	247458690	CARBON BRUSH 6X8

NOTICE

Part numbers on this Suggested Spare Parts list may supersede/replace the part numbers shown in the following parts lists.

Go to Discount-Equipment.com to order your parts

MOTOR ASSY.

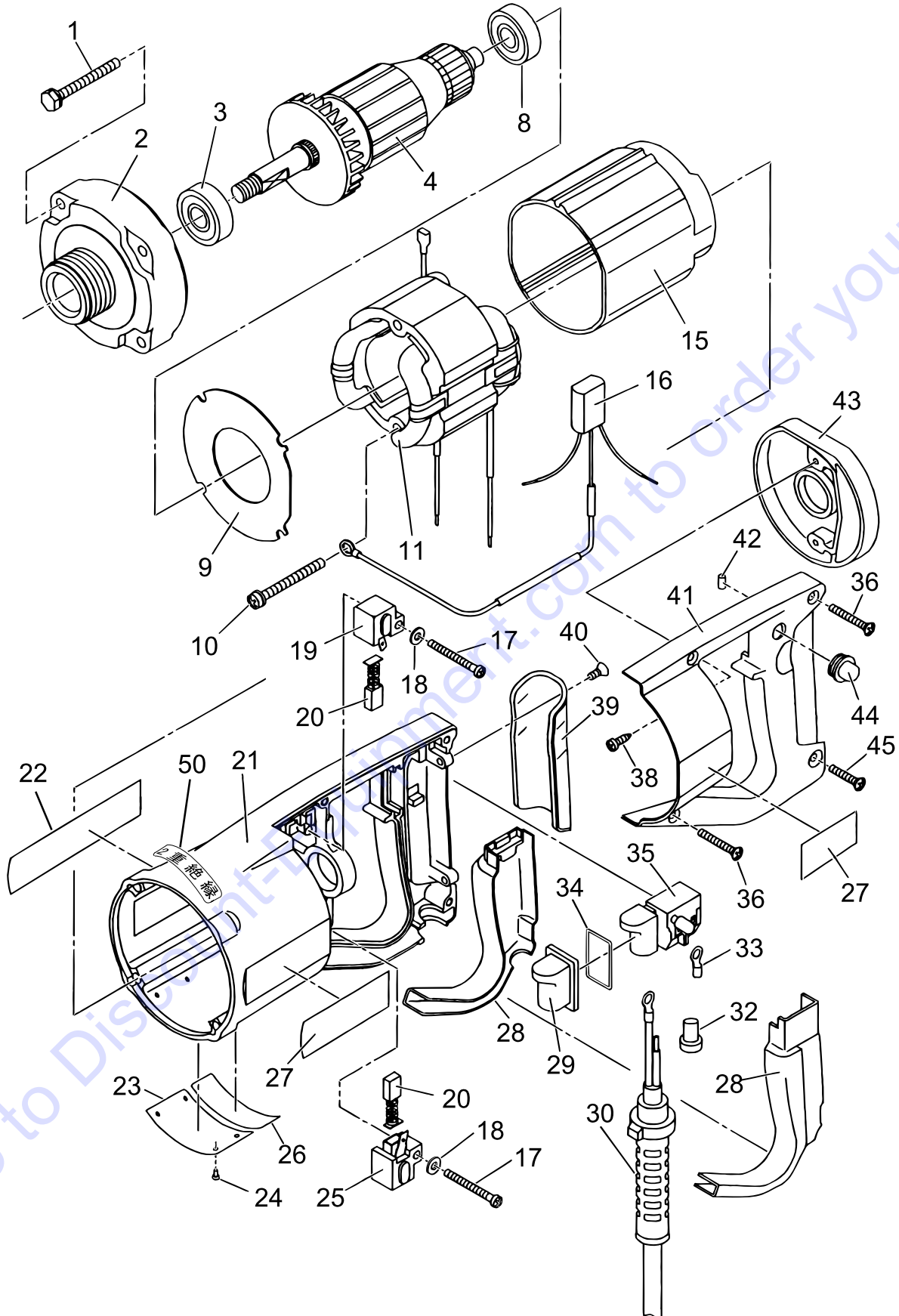

MOTOR ASSY.

<u>NO.</u>	<u>PART NO.</u>	<u>PART NAME</u>	<u>QTY.</u>	<u>REMARKS</u>
1	002240530	BOLT 5X30 SW/SUS	4	
2	247458630	L-BRACKET	1	
3	042506000	BEARING 6000ZZSG	1	
4	247010102	ARMATURE ASSY./110-120V	1	MGX1
4	247010104	ARMATURE ASSY./220-240V	1	MGX2
8	047110040	BEARING 609ZZ	1	
9	247458570	FAN GUIDE	1	
10	091505060	SCREW 5X60 W/SW	2	
11	247010202	STATOR ASSY. (110-120V)	1	MGX1
11	247010204	STATOR ASSY. (220-240V)	1	MGX2
15	247216910	STATOR INSULATION	1	
16	2474-58640	CONDENSER ASSY.	1	
17	01160402	SCREW 4X25	2	
18	033910180	POLY CARBONATE WASHER M4	2	
19	247458700	BRUSH HOLDER-L	1	
20	247458690	CARBON BRUSH 6X8	2	
21	247346140	FRAME	1	
23	920211100	NAMEPLATE	1	CONTACT MQ PARTS DEPT.
24	233010020	RIVET 2.3X5	4	
25	247458710	BRUSH HOLDER-R	1	
26	920110460	DECAL, CAUTION/COMBINATION	1	NP-1046
28	247910080	WIRE INSULATION (L,R SET)	1	INCLUDES ITEM W/#
29	247460060	SWITCH COVER	1	
30	247446150	CABTYRE CORD ASSY. W/PLUG	1	
32	261011090	TERMINAL 2-SD	1	
33	243011130	TERMINAL TGV1.25-4	1	
35	247346160	TRIGGER SWITCH	1	
36	092404022	SCREW 4X22 SUS	3	
38	094010027	TAPPING SCREW 4X10	2	
39	247458600	VIBRATION PROOF COVER	1	
40	092404008	SCREW 4X8 SUS	2	
41	247458620	BODY COVER	1	
42	247458680	RUBBER PIN	1	
43	247458660	CAP	1	
44	247458590	SWITCH LOCK COVER	1	
45	092404018	SCREW 4X18 SUS	1	
46#	247461180	CONTRACTION TUBE 25-40L	1	
47	247460080	DUST PROOF SEET1	2	
48	247460090	DUST PROOF SEET2	1	
50	920110550	DECAL, DOUBLE INSULATION	1	
60	920900030	DECAL, SET, MIKASA (L,R)	1	

SHAFT/HEAD ASSY.

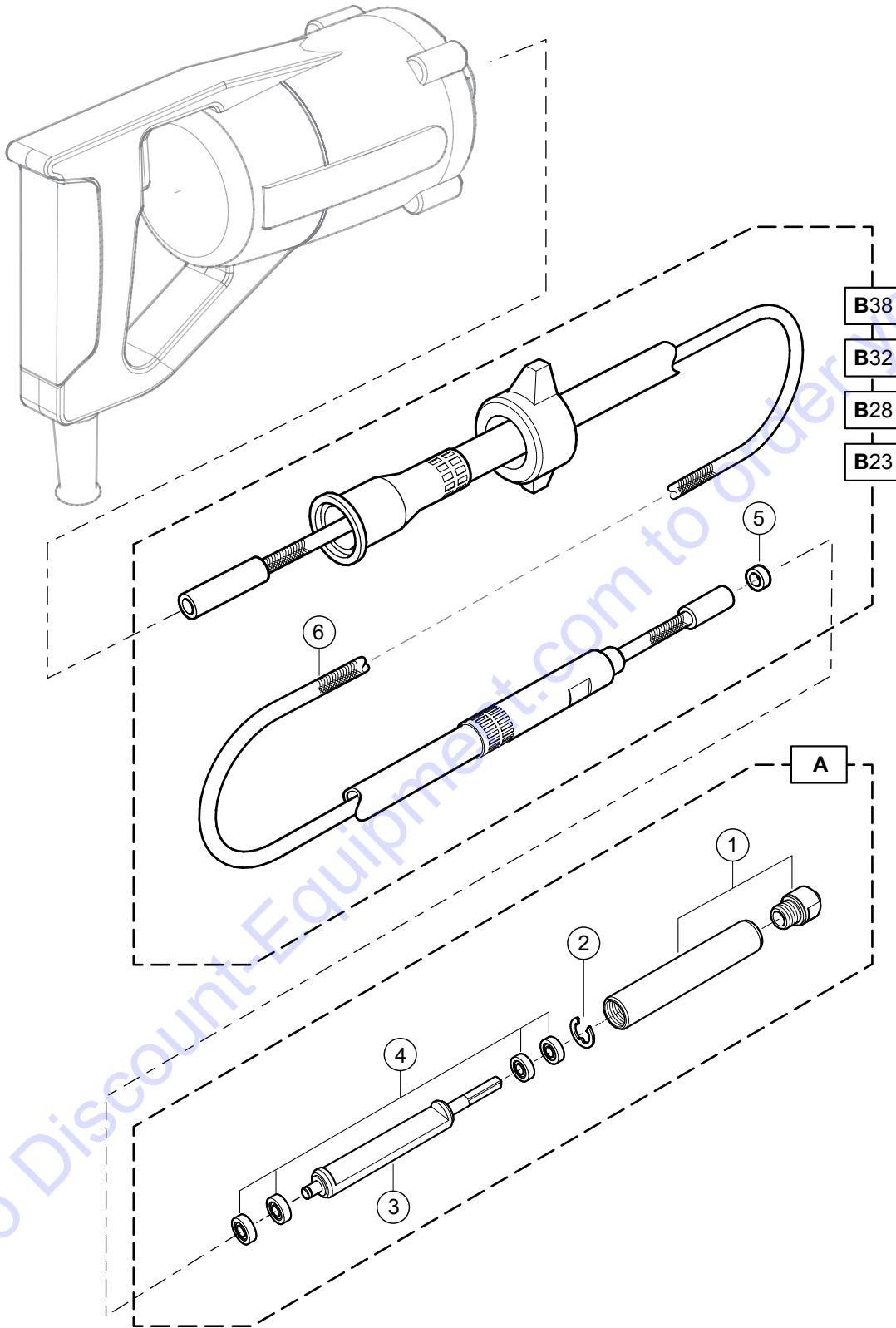

SHAFT/HEAD ASSY.

<u>NO.</u>	<u>PART NO.</u>	<u>PART NAME</u>	<u>QTY.</u>	<u>REMARKS</u>
A	242913040	VIBRATING HEAD ASSY., .905 IN. (23 MM)	1	MGX12325/MGX22325 INCLUDES ITEMS W/ #
A	242913010	VIBRATING HEAD ASSY., 1.1 IN. (28 MM)	1	MGX12810/MGX22810 MGX12825/MGX22825 INCLUDES ITEMS W/ \$
A	242913020	VIBRATING HEAD ASSY., 1.25 IN. (32 MM) 1		MGX13225/MGX23225 INCLUDES ITEMS W/ %
A	242913030	VIBRATING HEAD ASSY., 1.50 IN. (38 MM)	1	MGX13810/MGX23810 MGX13825/MGX23825 INCLUDES ITEMS W/ @
B23	242923330	LEAD SHAFT ASSY., 8.2 FT. (2.5 METERS).....	1	MGX12325/MGX22325 INCLUDES ITEM W/ +
B28	242923220	LEAD SHAFT ASSY., 3.2 FT. (1 METER)	1	MGX12810/MGX22810 INCLUDES ITEM W/ &
B28	242923340	LEAD SHAFT ASSY., 8.2 FT. (2.5 METERS).....	1	MGX12825/MGX22825 INCLUDES ITEM W/ &
B32	242923350	LEAD SHAFT ASSY., 8.2 FT. (2.5 METERS)	1	MGX13225/MGX23225 INCLUDES ITEM W/ ^
B38	242923300	LEAD SHAFT ASSY., 3.2 FT. (1 METER)	1	MGX13810/MGX23810 INCLUDES ITEM W/ *
B38	242923360	LEAD SHAFT ASSY., 8.2 FT. (2.5 METERS)	1	MGX13825/MGX23825 INCLUDES ITEM W/ *

SHAFT/HEAD ASSY.

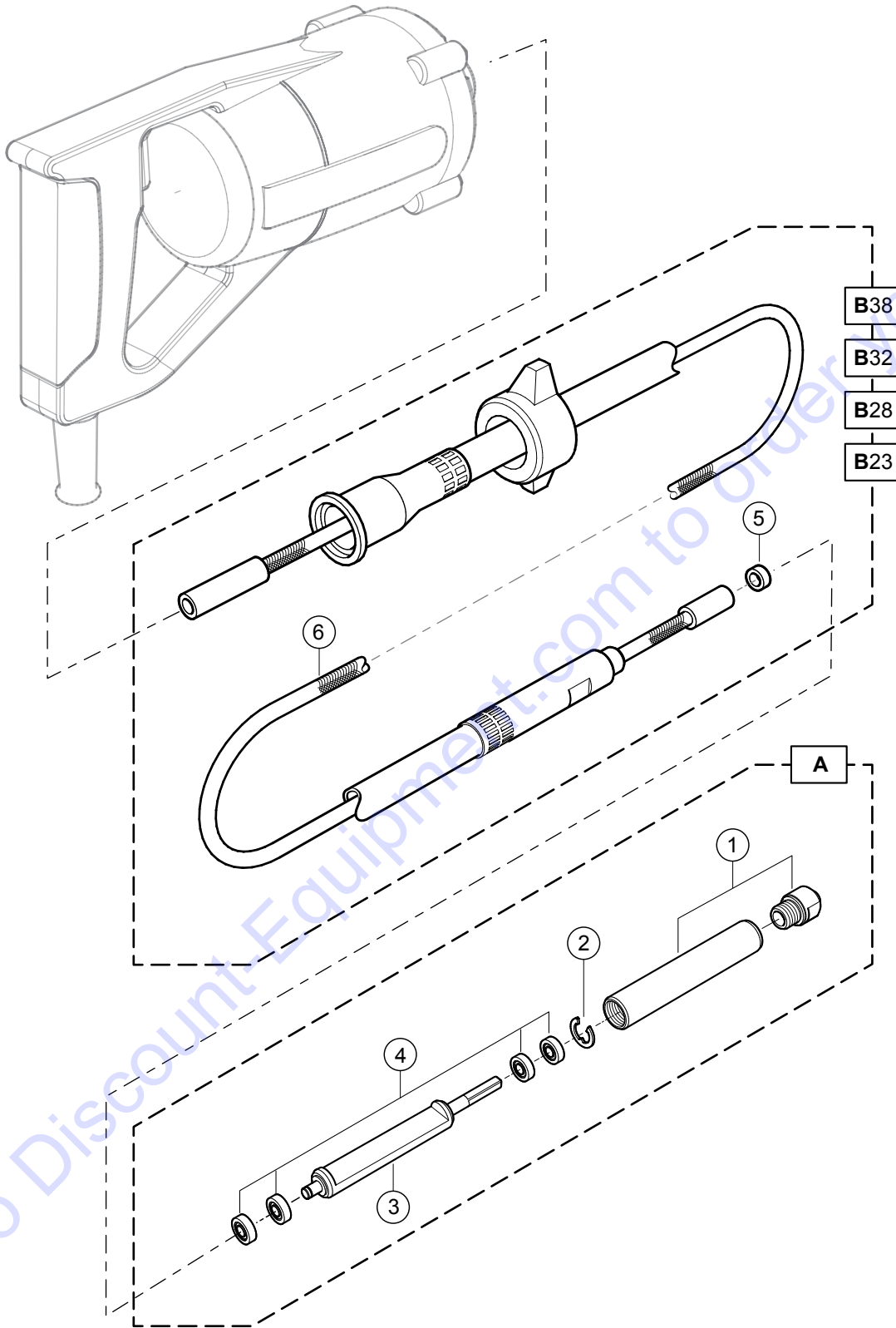

SHAFT/HEAD ASSY.

NO.	PART NO.	PART NAME	QTY.	REMARKS
1#	242953040	CASE ASSY.....	1.....	MGX12325/MGX22325
1\$	242953010	CASE ASSY.....	1.....	MGX12810/MGX22810 MGX12825/MGX22825
1%	242953020	CASE ASSY.....	1.....	MGX13225/MGX23225
1@	242953030	CASE ASSY.....	1.....	MGX13810/MGX23810 MGX13825/MGX23825
2#	080300060	SNAP RING.....	1.....	MGX12325/MGX22325
2\$	080300070	SNAP RING.....	1.....	MGX12810/MGX22810 MGX12825/MGX22825
2%	080300080	SNAP RING.....	1.....	MGX13225/MGX23225
2@	080300090	SNAP RING.....	1.....	MGX13810/MGX23810 MGX13825/MGX23825
3#	242336950	ECCENTRIC ROTATOR.....	1.....	MGX12325/MGX22325
3\$	242321540	ECCENTRIC ROTATOR.....	1.....	MGX12810/MGX22810 MGX12825/MGX22825
3%	242321550	ECCENTRIC ROTATOR.....	1.....	MGX13225/MGX23225
3@	242321560	ECCENTRIC ROTATOR.....	1.....	MGX13810/MGX23810 MGX13825/MGX23825
4#	042500697	BEARING 697ZZSG/MC3.....	4.....	MGX12325/MGX22325
4\$	040300608	BEARING 608/MC3.....	4.....	MGX12810/MGX22810 MGX12825/MGX22825
4%	040300629	BEARING 629/MC3.....	4.....	MGX13225/MGX23225
4@	040006200	BEARING 6200.....	4.....	MGX13810/MGX23810 MGX13825/MGX23825
5+	064901030	OIL SEAL, DS7144.....	1.....	MGX12325/MGX22325
5&	060600010	OIL SEAL, VC-8184.....	1.....	MGX12810/MGX22810 MGX12825/MGX22825
5^	060600020	OIL SEAL, VC-9225.....	1.....	MGX13225/MGX23225
5*	060201010	OIL SEAL, SC-10257.....	1.....	MGX13810/MGX23810 MGX13825/MGX23825
6+&^*		FLEXIBLE SHAFT.....	1.....	NOT SOLD SEPARATELY

PARTS FINDER

**Search Website
by Part Number**



**Search Manual
Library For Parts
Manual & Lookup Part
Numbers – Purchase
or Request Quote**

Search Manuals

Enter your information to help us find the right parts manual for your machine.

* Brand:

* Model:

* Serial:

* Part Number:

SEARCH

**Can't Find Part or
Manual? Request Help
by Manufacturer,
Model & Description**

Parts Order Form

Please fill in the following information to help us find the right part for your machine.

Manufacturer:	<input type="text"/>
Model:	<input type="text"/>
Description:	<input type="text"/>
Part Number:	<input type="text"/>
Quantity:	<input type="text"/>
Notes:	<input type="text"/>

Submit

Discount-Equipment.com is your online resource for quality parts & equipment.

Florida: **561-964-4949** Outside Florida TOLL FREE: **877-690-3101**

Need parts?

Click on this link: <http://www.discount-equipment.com/category/5443-parts/> and choose one of the options to help get the right parts and equipment you are looking for. Please have the machine model and serial number available in order to help us get you the correct parts. If you don't find the part on the website or on one of the online manuals, please fill out the request form and one of our experienced staff members will get back to you with a quote for the right part that your machine needs.

We sell worldwide for the brands: Genie, Terex, JLG, MultiQuip, Mikasa, Essick, Whiteman, Mayco, Toro Stone, Diamond Products, Generac Magnum, Airman, Haulotte, Barreto, Power Blanket, Nifty Lift, Atlas Copco, Chicago Pneumatic, Allmand, Miller Curber, Skyjack, Lull, Skytrak, Tsurumi, Husquvarna Target, Stow, Wacker, Sakai, Mi-T-M, Sullair, Basic, Dynapac, MBW, Weber, Bartell, Bennar Newman, Haulotte, Ditch Runner, Menegotti, Morrison, Contec, Buddy, Crown, Edco, Wyco, Bomag, Laymor, EZ Trench, Bil-Jax, F.S. Curtis, Gehl Pavers, Heli, Honda, ICS/PowerGrit, IHI, Partner, Imer, Clipper, MMD, Koshin, Rice, CH&E, General Equipment, Amida, Coleman, NAC, Gradall, Square Shooter, Kent, Stanley, Tamco, Toku, Hatz, Kohler, Robin, Wisconsin, Northrock, Oztec, Toker TK, Rol-Air, APT, Wylie, Ingersoll Rand / Doosan, Innovatech, Con X, Ammann, Mecalac, Makinex, Smith Surface Prep, Small Line, Wanco, Yanmar