

OPERATION AND PARTS MANUAL



FCG1 SERIES CONCRETE SAW

Revision #3 (03/15/10)



THIS MANUAL MUST ACCOMPANY THE EQUIPMENT AT ALL TIMES.

PARTS FINDER

**Search Website
by Part Number**



**Search Manual
Library For Parts
Manual & Lookup Part
Numbers – Purchase
or Request Quote**

Search Manuals

Enter your information to help us find the right parts manual for your machine.

* Brand:

* Model:

* Serial:

* Part Number:

SEARCH

**Can't Find Part or
Manual? Request Help
by Manufacturer,
Model & Description**

Parts Order Form

Please fill in the following information to help us find the right part for your machine.

Manufacturer:	<input type="text"/>
Model:	<input type="text"/>
Description:	<input type="text"/>
Part Number:	<input type="text"/>
Quantity:	<input type="text"/>
Notes:	<input type="text"/>

Submit

Discount-Equipment.com is your online resource for quality parts & equipment.

Florida: **561-964-4949** Outside Florida TOLL FREE: **877-690-3101**

Need parts?

Click on this link: <http://www.discount-equipment.com/category/5443-parts/> and choose one of the options to help get the right parts and equipment you are looking for. Please have the machine model and serial number available in order to help us get you the correct parts. If you don't find the part on the website or on one of the online manuals, please fill out the request form and one of our experienced staff members will get back to you with a quote for the right part that your machine needs.

We sell worldwide for the brands: Genie, Terex, JLG, MultiQuip, Mikasa, Essick, Whiteman, Mayco, Toro Stone, Diamond Products, Generac Magnum, Airman, Haulotte, Barreto, Power Blanket, Nifty Lift, Atlas Copco, Chicago Pneumatic, Allmand, Miller Curber, Skyjack, Lull, Skytrak, Tsurumi, Husquvarna Target, Stow, Wacker, Sakai, Mi-T-M, Sullair, Basic, Dynapac, MBW, Weber, Bartell, Bennar Newman, Haulotte, Ditch Runner, Menegotti, Morrison, Contec, Buddy, Crown, Edco, Wyco, Bomag, Laymor, EZ Trench, Bil-Jax, F.S. Curtis, Gehl Pavers, Heli, Honda, ICS/PowerGrit, IHI, Partner, Imer, Clipper, MMD, Koshin, Rice, CH&E, General Equipment, Amida, Coleman, NAC, Gradall, Square Shooter, Kent, Stanley, Tamco, Toku, Hatz, Kohler, Robin, Wisconsin, Northrock, Oztec, Toker TK, Rol-Air, APT, Wylie, Ingersoll Rand / Doosan, Innovatech, Con X, Ammann, Mecalac, Makinex, Smith Surface Prep, Small Line, Wanco, Yanmar



WARNING



CALIFORNIA — Proposition 65 Warning

Engine exhaust and some of its constituents, and some dust created by power sanding, sawing, grinding, drilling and other construction activities contains chemicals known to the State of California to cause cancer, birth defects and other reproductive harm.

Some examples of these chemicals are:

- Lead from lead-based paints.
- Crystalline silica from bricks.
- Cement and other masonry products.
- Arsenic and chromium from chemically treated lumber.

Your risk from these exposures varies, depending on how often you do this type of work. To reduce your exposure to these chemicals: **ALWAYS** work in a well ventilated area, and work with approved safety equipment, such as dust masks that are specially designed to filter out microscopic particles.

Go to DiscountAutoPart.com to order your parts

FCG1 CONCRETE SAW—TABLE OF CONTENTS

MULTIQUIP— FCG1 CONCRETE SAW

Here's How To Get Help	3
Table Of Contents	4
Specifications	5
Dimensions	6
Safety Message Alert Symbols	7-8
Rules For Safe Operation	9-11
Operation And Safety Decals	12
General Information	13
Components	14-15
Basic Engine	16
Guards, Covers and V-Belts	17-18
Blades	19
Blade Placement	20-22
Pre-Inspection	23
Operation	24-27
Maintenance	28-29
Troubleshooting (Saw)	30
Troubleshooting (Engine)	31-32
Explanation Of Codes In Remarks Column	34
Suggested Spare Parts	35

Component Drawings

Decal Locator	36-37
Guards Assembly	38-39
Guides Assembly	40-41
Undercarriage Assembly	42-43
Handle & Depth Adjuster Assembly	44-45
Engine & Blade Drive Assembly	46-47

Honda GX200QXC9 Engine

Air Cleaner Assembly	48-49
Camshaft Assembly	50-51
Carburetor Assembly	52-53
Control Assembly	54-55
Crankcase Cover Assembly	56-57
Crankshaft Assembly	58-59
Cylinder Barrel Assembly	60-61
Cylinder Head Assembly	62-63
Fan Cover Assembly	64-65
Flywheel Assembly	66-67
Fuel Tank Assembly	68-69
Ignition Assembly	70-71
Muffler Assembly	72-73
Piston Assembly	74-75
Recoil Starter Assembly	76-77
Gasket Kit Assembly	79
Labels Assembly	80-81
Terms and Conditions of Sale	82

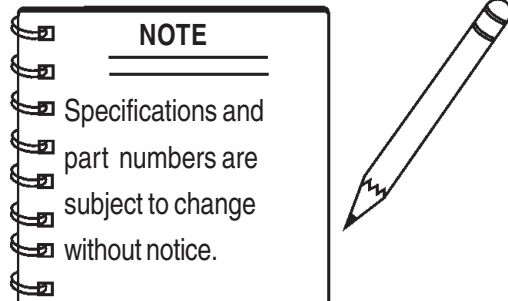

FCG1 CONCRETE SAW— SPECIFICATIONS

Table 1. FCG1 Concrete Saw Specifications

Arbor Size in. (mm)	0.75 In. (19.1 mm)
Blade Capacity in. (mm)	10 In. (254 mm)
Cutting Depth in. (mm)	3.25 In. (82.6 mm)
Nominal Mass* lbs. (kg)	103 Lb. 47 Kg)
Maximum Operating Mass** lbs. (kg)	113 Lb. (51 Kg)
A-Weighted Sound Pressure Level at Operator's Position	88.3 dB (A)
Guaranteed Sound Power Level	110.0 dB (A)
Hand/Arm Vibration (At Handle)***	7.14 m/s2

* **Nominal Mass:** Mass without blade, all fluid tanks empty, any optional parts removed.

** **Maximum Operating Mass:** Includes blade, all fluid tanks full, any necessary components installed.

*** **Hand/Arm Vibration** (at handle) results with FCG1 Saw cutting cured concrete at a depth of 1/2" (12.7 mm) with a 10" (254 mm) blade at FULL THROTTLE.

Table 2. Specifications (Engine)

	Model	HONDA GX200QXC9	ROBIN EX21
Engine	Type	Air-cooled 4 stroke, Single Cylinder, OHV, Gasoline Engine	Air-cooled 4 stroke, Single Cylinder, OHV, Gasoline Engine
	Bore X Stroke	2.7 in. X 2.1 in. (68 mm x 54 mm)	2.64 in. X 2.36 in. (67 mm x 60 mm)
	Displacement	12.0 cu-in. (196 cc)	12.87 cu-in. (211 cc)
	Max Output	6.4 H.P./3600 R.P.M. (4.8 kW, 6.5 PS)	7.0 H.P./4000 R.P.M. (5.1 kW, 7.0 PS)
	Fuel Tank Capacity	Approx. 0.95 U.S. Gallons (3.6 Liters)	Approx. 0.95 U.S. Gallons (3.6 Liters)
	Fuel	Unleaded Automobile Gasoline 86 Octane or higher	Unleaded Automobile Gasoline 86 Octane or higher
	Lube Oil Capacity	0.63 US qt (0.60 liter)	0.624 US qt (0.60 liter)
	Speed Control Method	Centrifugal Fly-weight Type	Centrifugal Fly-weight Type
	Starting Method	Recoil Start	Recoil Start
	Dimension (L x W x H)	12.3 x 14.8 X 13.2 in. (313 X 376 X 335 mm)	12.24 x 14.4 X 13.19 in. (311 X 366 X 335 mm)
Dry Net Weight	35.3 lbs (16 Kg.)	35.28 lbs (16 Kg.)	

FCG1 CONCRETE SAW— DIMENSIONS

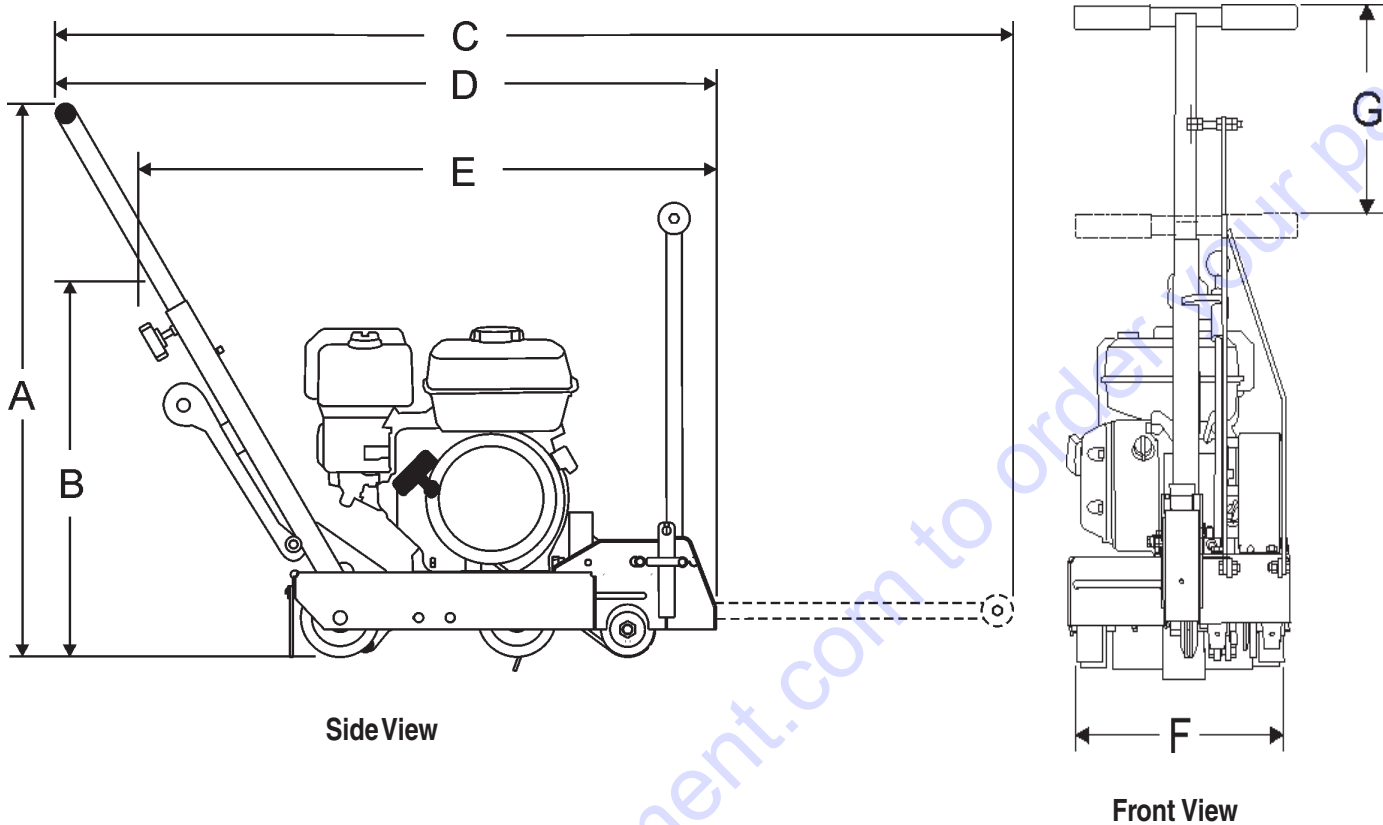

Figure 1. FCG1 Concrete Saw Dimensions

Table 3. FCG1 Concrete Saw Dimensions

REFERENCE LETTER	DESCRIPTION	DIMENSION (CM)
A	Max Height (Handle Bars Fully Raised)	118.7 CM (46.75 In.)
B	Max Height (Handle Bars Fully Lowered)	81.3 CM (32.0 In.)
C	Max Length (Handle Bars Fully Raised & Front Pointer Lowered)	172.7 CM (68 In.)
D	Max Length (Handle Bars Fully Raised & Front Pointer Raised)	121.9 CM (48 In.)
E	Max Length (Handle Bars Fully Lowered & Front Pointer Raised)	99 CM (39 In.)
F	Max Overall Width	34.3 CM (13.5 In.)
G	Max Handle Bar Deflection	37.5 CM (14.75 In.)
Crated Dimension (L x W x H)		87.6 CM x 34.3 CM x 58.4 CM (34.5 In. x 13.5 In. x 23 In.)

FCG1 CONCRETE SAW— SAFETY MESSAGE ALERT SYMBOLS

FOR YOUR SAFETY AND THE SAFETY OF OTHERS!

Safety precautions should be followed at all times when operating this equipment. Failure to read, understand and comply with the Safety Messages and Operating Instructions could result in injury to yourself and others.

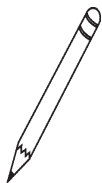
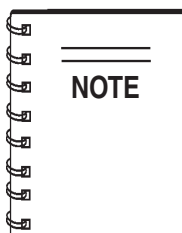

This Owner's Manual has been developed to provide instructions for the safe and efficient operation of the FCG1 Concrete Saw. For engine maintenance information, please refer to the engine manufacturer's instructions for data relative to its safe operation.

Before using this Concrete Saw, ensure that the operating individual has read, understands, and complies with all instructions in this manual.

SAFETY MESSAGE ALERT SYMBOLS

The three (3) Safety Messages shown below will inform you about potential hazards that could injure you or others. The Safety Messages specifically address the level of exposure to the operator, and are preceded by one of three words: **DANGER**, **WARNING**, or **CAUTION**.

DANGER

You **WILL** be **KILLED** or **SERIOUSLY INJURED** if you **DO NOT** follow these directions.

WARNING

You **CAN** be **KILLED** or **SERIOUSLY INJURED** if you **DO NOT** follow these directions.

CAUTION

You **CAN** be **INJURED** if you **DO NOT** follow these directions.

Potential hazards associated with FCG1 Concrete Saw operation will be referenced with Hazard Symbols which appear throughout this manual, and will be referenced in conjunction with Safety Message Alert Symbols.

HAZARD SYMBOLS

Lethal Exhaust Gases



Engine exhaust gases contain poisonous carbon monoxide. This gas is colorless and odorless, and can cause death if inhaled. **NEVER** operate this equipment in a confined area or enclosed structure that does not provide ample free flow air.

Explosive Fuel



Gasoline is extremely flammable, and its vapors can cause an explosion if ignited. **DO NOT** start the engine near spilled fuel or combustible fluids. **DO NOT** fill the fuel tank while the engine is running or hot. **DO NOT** overfill tank, since spilled fuel could ignite if it comes into contact with hot engine parts or sparks from the ignition system. Store fuel in approved containers, in well-ventilated areas and away from sparks and flames. **NEVER** use fuel as a cleaning agent.

Burn Hazards



Engine components can generate extreme heat. To prevent burns, **DO NOT** touch these areas while the engine is running or immediately after operations. **NEVER** operate the engine with heat shields or heat guards removed.

Rotating Parts



NEVER operate equipment with covers, or guards removed. Keep fingers, hands, hair and clothing away from all moving parts to prevent injury.

FCG1 CONCRETE SAW— SAFETY MESSAGE ALERT SYMBOLS



Accidental Starting



ALWAYS place the **ON/OFF** switch in the **OFF** position, when the saw is not in use.



Respiratory Hazard



ALWAYS wear approved respiratory protection.



Over Speed Conditions



NEVER tamper with the factory settings of the engine governor. Personal injury and damage to the engine or equipment can result if operating in speed ranges above maximum allowable.



Sight and Hearing hazard

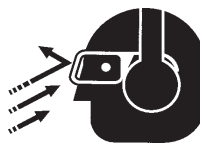

ALWAYS wear approved eye and hearing protection.



Guards and Covers In Place



NEVER operate the saw without blade guards and covers in place. Adhere to safety guidelines or other applicable local regulations.



Equipment Damage Messages

Other important messages are provided throughout this manual to help prevent damage to your slab saw, other property, or the surrounding environment.



CAUTION

This concret/asphalt saw, other property, or the surrounding environment could be damaged if you do not follow instructions.

FCG1 CONCRETE SAW— RULES FOR SAFE OPERATION

RULES FOR SAFE OPERATION

WARNING

Failure to follow instructions in this manual may lead to serious injury or even death! This equipment is to be operated by trained and qualified personnel only! This equipment is for industrial use only.

The following safety guidelines should always be used when operating the FCG1 Saw.

SAFETY

- **DO NOT** operate or service this equipment before reading this entire manual. The manual must be kept available and accessible to the operator. 
- This equipment should not be operated by persons under the minimum statutory age limit.
- **NEVER** use this machine for any purpose other than those described in this manual.
- **NEVER** operate the saw without proper protective clothing, shatterproof glasses, steel-toed boots and other protective devices required for the job.



- **NEVER** use accessories or attachments which are not recommended by Multiquip for this equipment. Damage to the equipment and/or injury to user may result.
- Manufacturer does not assume responsibility for any accident due to equipment modifications. Unauthorized equipment modification will void all warranties. Any modification which could lead to a change in the original characteristics of the machine should be made only by the manufacturer who shall confirm that the machine is in conformity with appropriate safety regulations.

- **NEVER** operate this equipment when not feeling well due to fatigue, illness or taking medicine.
- **NEVER** operate the saw under the influence of drugs or alcohol.
- Replace nameplate, operation and safety decals when they become difficult to read.
- **ALWAYS** check the saw for loosened hardware such as nuts and bolts before starting.

- **NEVER** touch the hot exhaust manifold, muffler or cylinder. Allow these parts to cool before servicing the saw.



- **High Temperatures** – Allow the engine to cool before adding fuel or performing service and maintenance functions. Contact with **hot!** components can cause serious burns.

- The engine of this saw requires an adequate free flow of cooling air. **NEVER** operate the saw in any enclosed or narrow area where free flow of the air is restricted. If the air flow is restricted it will cause serious damage to the saw's engine and may cause injury to people. Remember the saw's engine gives off **DEADLY** carbon monoxide gas.



- **ALWAYS** refuel in a well-ventilated area, away from sparks and open flames.

- **ALWAYS** use extreme caution when working with **flammable** liquids. When refueling, **STOP** the engine and allow it to cool.

- **NEVER** operate the saw in an explosive atmosphere where fumes are present, or near combustible materials. An explosion or fire could result in severe **bodily harm or even death**.

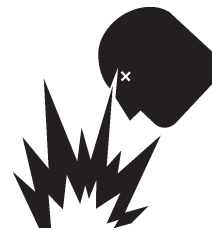

- **NEVER** smoke around or near the machine. Fire or explosion could result from **fuel vapors**, or if fuel is spilled on a **hot!** engine.



- Topping-off to filler port is dangerous, as it tends to spill fuel.
- **NEVER** use fuel as a cleaning agent.

FCG1 CONCRETE SAW— RULES FOR SAFE OPERATION

General Safety

- **ALWAYS** read, understand, and follow procedures in Operator's Manual before attempting to operate equipment.
- **ALWAYS** be sure the operator is familiar with proper safety precautions and operating techniques before using the saw.
- **NEVER** leave the machine *unattended* while running.
- Apply the brakes when leaving or when using on a slope.
- Maintain this equipment in a safe operating condition at all times.
- **ALWAYS** stop the engine before servicing, adding fuel and oil.
- **NEVER** run the engine without the air filter. Severe engine damage could occur.
- **ALWAYS** service air cleaner frequently to prevent carburetor malfunction.
- **AVOID** wearing jewelry or loose fitting clothing that may snag on the controls or moving parts, this can cause a serious injury.
- **ALWAYS** keep clear of *rotating* or *moving parts* while the saw is in operation.
- **ALWAYS** store equipment properly when it is not being used. Equipment should be stored in a clean, dry location out of the reach of children.
- **ALWAYS** keep the work area well organized.
- **ALWAYS** Clear the cutting area of any debris, tools, etc. that would constitute a hazard while the saw is in operation.

WARNING

ALWAYS check to make sure that the operating area is clear before starting the engine.

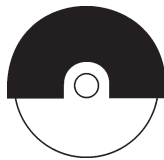

- No one other than the operator is to be in the working area when the saw is in operation.
- Always observe all applicable compulsory regulations relevant to environmental protection, especially, fuel storage, the handling of hazardous substances, and the wearing of protective clothing and equipment. Instruct the user as necessary, or, as the user, request this information and training.

Diamond Blade Safety

- Use appropriate steel centered diamond blades manufactured for use on concrete saws. See further blade information on pages 21 through 23.

WARNING

ALWAYS inspect diamond blades before each use. The blade should exhibit no cracks, dings, or flaws in the steel centered core and/or rim. Center (arbor) hole must be undamaged and true. All damaged blades must be discarded.



- Examine blade flanges for damage and excessive wear.
- Ensure the cleanliness of the blade before blade is installed. Blade should fit snugly on the shaft and against the inside/outside blade flanges.
- Ensure the blade is marked with an operating speed greater than the spindle speed of the saw.

WARNING

Only cut the material that is specified for the diamond blade. Read the specifications of the diamond blade to ensure the proper tool has been matched to the material being cut. The saw has been engineered for **DRY CUTTING**. Ensure a **DRY CUTTING** blade is being used.

- **ALWAYS** keep blade guards in place. Exposure of the diamond blade must not exceed 180 degrees.
- Ensure that the diamond blade does not come into contact with the ground or surface during transportation. **DO NOT** drop the diamond blade on ground or surface.
- The engine governor is set to regulate maximum engine speed in a no-load condition. Do not tamper with the engine governor to increase the speed. Increasing the engine speed could allow the maximum rated spindle speed to be exceeded, creating an unsafe condition.
- Ensure that the blade is mounted for proper operating direction. (See Figure 12)
- Adhere to the Blade Manufacturer's recommendations on handling, storage, and safe usage of blades.

FCG1 CONCRETE SAW— RULES FOR SAFE OPERATION

Maintenance Safety

- **NEVER** lubricate components or attempt service on a running machine.
- **ALWAYS** allow the machine a proper amount of time to cool before servicing.
- Keep the machinery in proper running condition.
- Fix damage to the machine immediately and **ALWAYS** replace broken parts.
- Dispose of hazardous waste properly. Examples of potentially hazardous waste are used motor oil, fuel and fuel filters.
- **DO NOT** use food or plastic containers to dispose of hazardous waste.

Saw Transportation Safety

- **DO NOT** use the handle bars and/or front pointer as lifting points.
- **ALWAYS** use ramps capable of supporting the weight of the saw and the operator to load and unload the saw.
- If the saw must be lifted, use the lifting bale and a crane or forklift with a rated lifting capacity for the saw. Never attempt to lift the saw by yourself.
- When transporting the saw, place the saw directly inside towing vehicle truck-bed or onto trailer and tie-down securely.
- **NEVER** attempt to tow the untrailerred saw behind a vehicle.
- **DO NOT** use on slopes or on extremely uneven surfaces.
- **NEVER** tip the engine to extreme angles as it may cause oil to gravitate into the cylinder head making the engine start difficult.
- **NEVER** load, unload, or transport the saw with the blade mounted.

WARNING

All displacement of the machine outside the cutting area shall be carried out with the tool not in rotation.

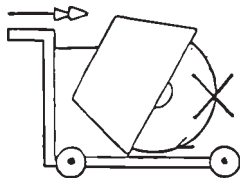

Emergencies

- **ALWAYS** know the location of the nearest **fire extinguisher**.



- **ALWAYS** know the location of the nearest **first aid kit**.



- In emergencies **ALWAYS** know the location of the nearest phone or **keep a phone on the job site**. Also know the phone numbers of the nearest **ambulance**, **doctor** and **fire department**. Knowing this information is invaluable in the case of an emergency and could keep a serious situation from becoming a tragic one.



FCG1 CONCRETE SAW— OPERATION AND SAFETY DECALS

Machine Operation And Safety Decals

The FCG1 Concrete Saw is equipped with a number of safety decals (Figure 2). These decals are provided for operator safety and maintenance information. Should any of these decals become unreadable, replacements can be obtained from your dealer.













 <p>P/N 15581</p>		 <p>P/N 15580</p>	
 <p>P/N 25485 (large)</p>		 <p>P/N 35137</p>	
 <p>P/N 25482 (large)</p>		 <p>P/N 25867</p>	
 <p>P/N 36099 (ISO Blue)</p>		 <p>P/N 25427</p>	
 <p>P/N: 13118</p>	 <p>P/N 25491</p>	 <p>CONTACT DISCOUNT-EQUIPMENT</p>	
 <p>P/N 25483 (small)</p>	 <p>P/N 20525</p>		
 <p>P/N 25484 (small)</p>	 <p>DECAL SHEET INTL STDS P/N 11246</p>		

Figure 2. FCG1 Concrete Saw Decals

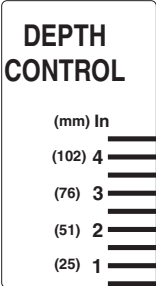
FCG1 CONCRETE SAW— GENERAL INFORMATION

Intended Use

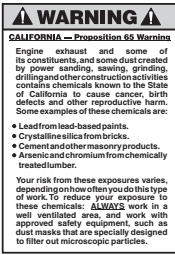
Operate the FCG1 Saw, tools and components in accordance with the manufacturer's instructions. Use of any other tools for stated operation is considered contrary to designated use. The risk of such use lies entirely with the user. The manufacturer cannot be held liable for damages as a result of misuse.

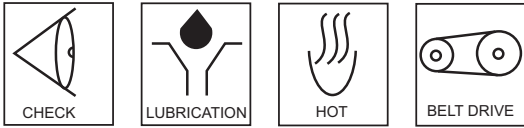
This saw is not intended for wet cutting. (The use of water sprayed onto the tool [blade] during the cutting operation).

FAMILIARIZATION

This FCG1 Saw is designed for dry sawing of concrete slabs utilizing diamond blades. The saw has been engineered for general and industrial flat sawing applications that include: **Joint Sawing** of Green Concrete, **Decorative Sawing** in Cured Concrete, **Light Demolition Sawing** and **"V" Groove Beveling**. The simple and compact nature of the SlabSaver makes it a perfect sawing tool for one person to operate and transport. The saw combines innovative features, top quality components, and a committed attention to state-of-the-art manufacturing.

For peak performance, the SlabSaver has been engineered to operate a powerful 6.5 HP (Honda) or 7 HP (Robin) Gasoline engine and 10" diameter diamond blades. This special design allows for fast/clean cuts in different materials at depths from 1/4" to 3 1/4".

For maximum performance and return on investment use:

Diamond Back

Diamond Blades.

The jig-welded reinforced heavy gauge steel frame and chassis assembly are designed to eliminate operational bending and/or flex that would lead to diminished blade performance. Also, the frame's general weight-to-strength ratio and center mounted blade design ensure accurate tracking in the cut.

A robust blade shaft bearing assembly ensures minimal flutter and shaft harmonics providing the most advantageous conditions for a diamond blade at operating speeds.

Heavy-duty front and rear axles, polyurethane wheels with permanently sealed ball bearings, and solid undercarriage assembly provide years of reliable use. The SlabSaver incorporates an innovative PosiLok raise/lower control assembly that provides fingertip control of blade orientation, infinitely adjustable locking blade depth control, and depth feed gauge.

Retractable front & rear pointers with "tracking wheels" are provided to support precise straight sawing. This system permits the operator to quickly adjust the blade cutting depth and safeguard against "blade-creep" during sawing operations. For operator comfort and ease of transportation & storage, an adjustable locking handle bar is provided.

Operator control of the saws is safely accomplished with adjustable handle bars, and a conveniently oriented raise/lower lever and depth adjustment wheel. An engine-off switch (Item 22 Fig. 3) located next to the handle lock allows the operator to safely turn the engine off from the operator's position and away from moving parts.

ENGINE

Pages 23-27 highlight fundamental aspects of engine inspection, starting, and shutdown. Refer to the engine Owner's Manual for specific instructions regarding operation, service and maintenance.

FCG1 CONCRETE SAW—COMPONENTS

CONTROLS & COMPONENTS

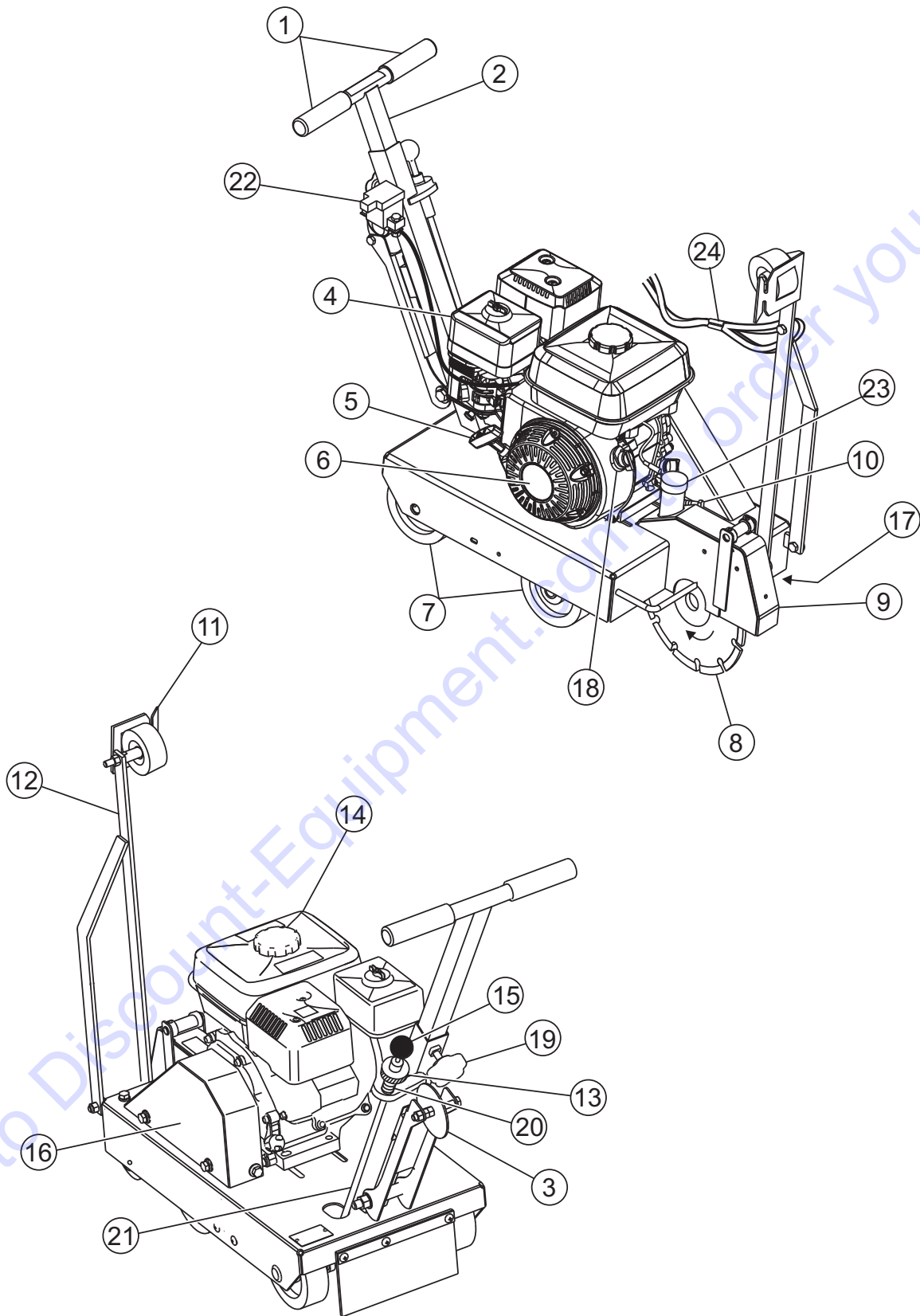

Figure 3. FCG1 Concrete Saw

FCG1 CONCRETE SAW—COMPONENTS

Figure 3 shows the location of the basic controls or components, for the FCG1 Concrete Saw. Listed below is a brief explanation of each control or component

1. **Hand Grips/Handlebar** – When operating the saw, place both hands on each grip to maneuver the saw.
2. **Adjustable Handle** – Set to comfortable operating position.
3. **Rear Guide** – Rear guide wheel drops into cut to assist in straight tracking.
4. **Air Filter** – Prevents dirt and debris from entering the engine air intake. Keep cleaned and replace when necessary.
5. **Recoil Starter Handle** – Pull to engage and start the engine.
6. **Recoil Starter Assembly** – Engages the engine when the handle is pulled and rewinds the starter rope when the handle is released.
7. **Wheels/Carrriage Assembly** – Heavy-duty polyurethane wheels with permanently sealed ball bearings.
8. **Diamond Blade** – 0.75" (19.1 mm) Arbor diameter. 10" blade capacity. 10" diameter provides for 1/4" to 3 1/4" depth of cut.
9. **Blade Guard** – Covers saw blade and flips up to allow blade to be changed.
10. **Belt Tension Adjuster** – Adjusts belt tension.
11. **Front Pointer** – Assists in straight tracking.
12. **Front Pointer Arm** – Pivots up for storage and pivots down for use.
13. **Depth Adjust Disk** – Turn disk clockwise or counter-clockwise to adjust the cutting depth up or down.
14. **Fuel Tank** – Use unleaded gasoline. Do not overfill.
15. **Shift Knob** – Moves Depth Stop Rod in or out of keyhole slot.
16. **V-Belt Cover** – Remove this cover to gain access to the V-belt. **NEVER** operate the saw with this cover removed.
17. **Arbor Shaft Grease Zerks** – Conveniently located for lubrication.
18. **On/Off Switch (Engine)**– Turn to the "ON" position to allow engine to be started and turn to the "OFF" position to prevent accidental starting.
19. **Handle Lock** – Lock handle height to a comfortable operating position.
20. **Screw Plunger** – Line up bottom edge of Depth Stop Rod on Screw Plunger across from desired depth line mark.
21. **Depth Stop Rod** – Holds blade above working surface or allows blade to cut into working surface at specified depth.
22. **Engine Shut-off Switch** – The Engine Shutdown Switch located next to the handle lock serves both as an Emergency Engine Shut-Off and as the primary Shutdown switch. This allows the operator to shutdown the saw safely away from moving parts.
23. **Dust Collection** – Provides for connection to suitable dust collection bag or vacuum system.
24. **Sash** – Allows for the lowering and raising of the front guide from the operator's position.

FCG1 CONCRETE SAW— BASIC ENGINE

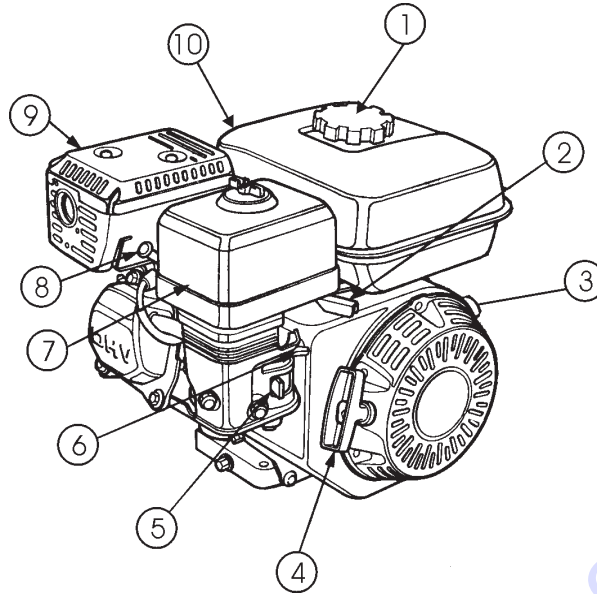

Figure 4. Engine Controls and Components

INITIAL SERVICING

The engine (Figure 4) must be checked for proper lubrication and filled with fuel prior to operation. Refer to the manufacturer's engine manual for instructions & details of operation and servicing.

1. **Fuel Filler Cap** – Remove this cap to add unleaded gasoline to the fuel tank. Make sure cap is tightened securely. **DO NOT** over fill.

6. **Choke Lever** – Used in the starting of a cold engine, or in cold weather conditions. The choke enriches the fuel mixture.
7. **Air Cleaner** – Prevents dirt and other debris from entering the fuel system. Remove wing-nut on top of air filter canister to gain access to filter element.

DANGER

Adding fuel to the tank should be done only when the engine is stopped and has had an opportunity to cool down. In the event of a fuel spill, **DO NOT** attempt to start the engine until the fuel residue has been completely wiped up, and the area surrounding the engine is dry.

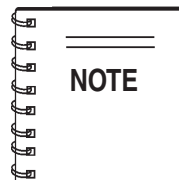
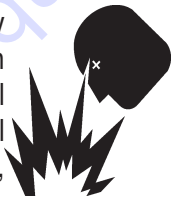

NOTE

Operating the engine without an air filter, with a damaged air filter, or a filter in need of replacement will allow dirt to enter the engine, causing rapid engine wear.

2. **Throttle Lever** – Used to adjust engine RPM speed (lever advanced forward **SLOW**, lever back toward operator **FAST**).
3. **Engine ON/OFF Switch** – **ON** position permits engine starting, **OFF** position stops engine operations.
4. **Recoil Starter (pull rope)** – Manual-starting method. Pull the starter grip until resistance is felt, then pull briskly and smoothly.
5. **Fuel Valve Lever** – **OPEN** to let fuel flow, **CLOSE** to stop the flow of fuel.

8. **Spark Plug** – Provides spark to the ignition system. Clean spark plug once a week.
9. **Muffler** – Used to reduce noise and emissions.

WARNING

Engine components can generate extreme heat. To prevent burns, **DO NOT** touch these areas while the engine is running or immediately after operating. **NEVER** operate the engine with the muffler removed.



10. **Fuel Tank** – Holds unleaded gasoline. For additional information refer to engine owner's manual.

FCG1 CONCRETE SAW — GUARDS, COVERS AND V-BELTS

WARNING

NEVER operate the saw without blade guards and covers in place. **DO NOT** operate with the front of the blade guard raised. The blade exposure cannot exceed 180 degrees during operation. Adhere to the safety guidelines of the **American National Standards Institute (ANSI) B7.1 and B7.5.**

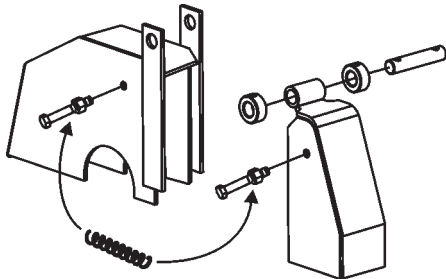

Figure 5. Blade Guard

V-belt Alignment and Tensioning

This concrete saw is equipped with a premium V-belt that has been aligned and tensioned by factory personnel. The V-belt must be aligned and tensioned for proper operation of the saw.

Use the following procedure to check the alignment of V-belt:

1. Remove the bolts that secure the V-belt cover (Figure 6) to the saw frame.

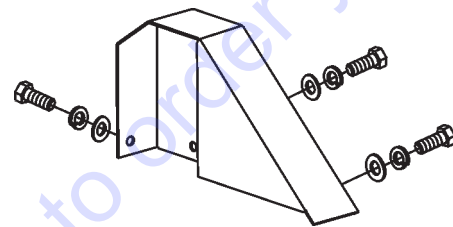

Figure 6. V-Belt Cover

CHECK the following on the "blade guard" (Figure 5):

- Ensure the capacity of the blade guard matches the diameter of your diamond blade.
- Check that the guard is bolted firmly upon the saw frame.
- Check that the spring tensioned front cover of the guard is firmly seated with the rear section of the guard, and there are no gaps. **NEVER** lift the blade guard while cutting.

2. Check uniform parallelism (Figure 7) of V-belt and pulley (sheaves). Use a straight-edge or machinist's square against both pulleys and adjust both pulleys until equally aligned.

V-belt Check

A worn or damaged V-belt can adversely affect the performance of the saw. If the V-belt is defective or worn, replace and the V-belt as outlined on page 20.

CAUTION

NEVER attempt to check the V-belt with the engine running. Severe injury can occur. Keep fingers, hands, hair and clothing away from all moving parts.

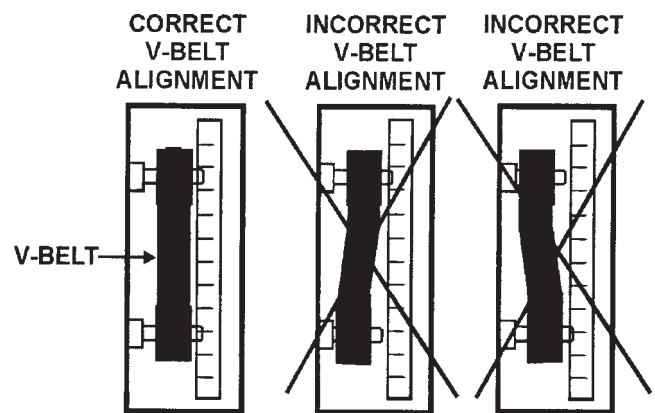

Figure 7. Pulley Alignment

3. Check V-belt tension by using a tension meter (6.0 - 9.0 lbs.) against the inside belt at a mid point between the two pulleys, or by deflecting the center belt at a mid point 3/8" (10 mm) to 1/2" (13 mm). See Figure 8.

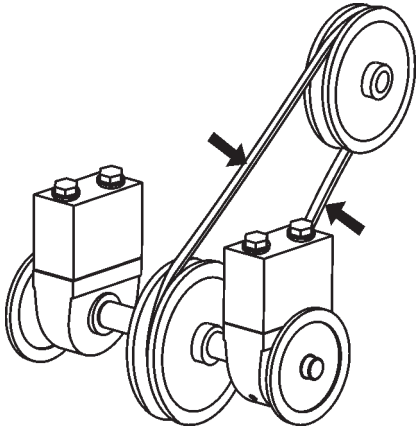
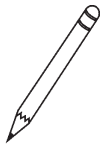
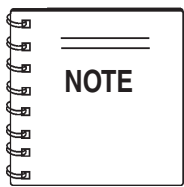

Figure 8. V-Belt Tension Check

- DO NOT** over or under tighten the V-belt. Severe damage can occur to the saw and engine crank shaft if the belt is over-tensioned. A decrease of power to the blade and poor performance will result if the belt is under-tensioned (loose on pulleys).



V-belt alignment must be rechecked after adjusting belt tension.

To Tighten the V-belt:

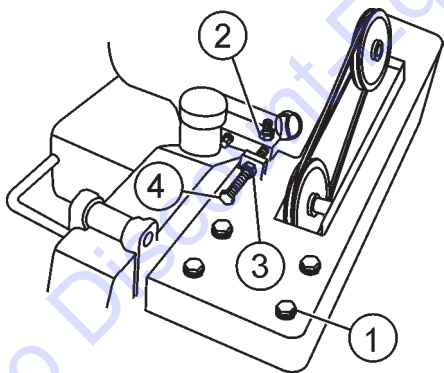

Figure 9. V-Belt Tension Adjust

- With V-belt guard removed, loosen the 4 engine mounting hex screws. (items 2 Figure 9)
- Loosen locking nut on the V-belt tension adjuster, (3).

- Tighten the adjusting hex screw (4) while holding the engine in place to maintain pulley alignment. (a screwdriver can be used as a lever at the rear belt guard mounting boss to hold the back of the engine while adjusting V-belt tension.)
- Re-tighten the locking nut (3).
- With V-belt held in proper alignment, (engine parallel with the frame), re-tighten the 4 engine mounting hex screws. Verify that all hex screws are properly tightened.

To Remove and Replace the V-belt:

If the V-belt become worn or damaged, replace it with P/N 15082 (Gates/Optibelt 3VX335).

- Remove the 3 hex screws holding the V-belt guard and remove the guard.
- Loosen the 4 engine mounting hex screws. (item 2, Figure 9)
- Loosen locking nut on the V-belt tension adjuster (item 3, Figure 9). Loosen the tension on the V-belt by turning the tension adjuster hex screw (item 4, Figure 9).
- Pull the engine ahead to provide slack in the V-belt.
- Loosen the 4 arbor shaft hex screws, (item 1, Figure 9).

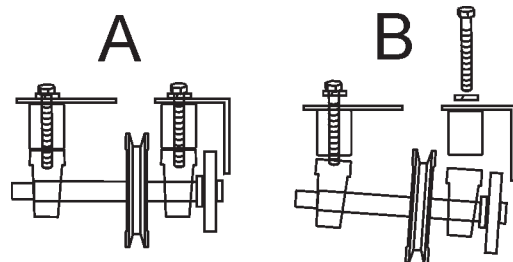

Figure 10. V-Belt Removal

- Remove the two outer arbor shaft hex screws allowing the outside of the shaft to drop, (B in Figure 10), allowing removal of the V-belt.
- Reinstall new V-belt.
- Re-install and tighten arbor shaft hex head screws.
- With V-belt held in proper alignment, re-tighten the 4 engine mounting hex screws. (Follow V-belt tightening procedures.)
- Re-install belt guard with 3 hex screws.

FCG1 CONCRETE SAW — BLADES

SPECIFIC TOOLS TO BE USED

This saw is to use tools (blades) as follows:

Steel Core Segmented or Continuous Diamond Rim Cutting Wheel.

Any other type of tool is not to be used. See Table 4 for specific blade usage for material.

WARNING

Failure to thoroughly inspect the diamond blade (Figure 11) for operational safety could result in damage to the blade, the saw, and may cause injury to the user or others in the operating area. All damaged blades must be discarded.



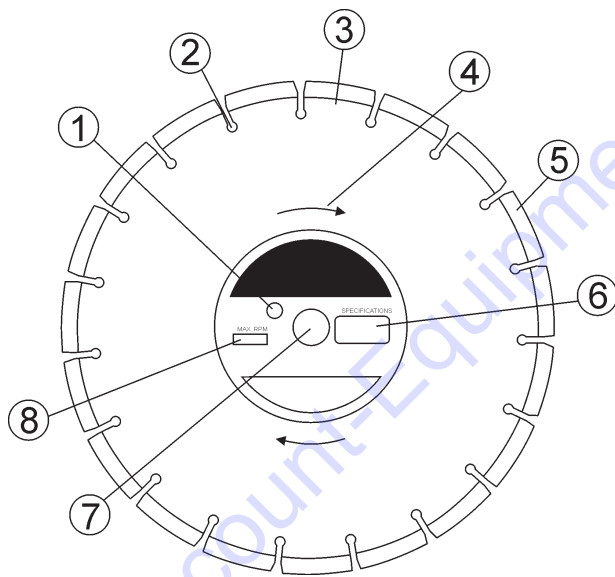
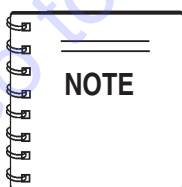

Figure 11. Diamond Blade



Adhere to the Blade Manufacturer's recommendations on handling, storage, and safe usage of blades.

1. **Drive Pin Hole** – A commonly located hole on the diamond blade core that prevents operational blade slippage between the inner & outer blade flanges (collars). Inspect the diameter of the hole to ensure there is no distortion, and that a snug fit develops between the hole and drive pin.
2. **Stress Relief Holes (Gullets)** – Check the steel core for cracks that may have propagated from the slots and/or gullets. Cracks indicate extreme fatigue failure and if sawing continues, catastrophic failure will occur.
3. **Edge Of The Steel Core** – Check the diameter edge for discoloration (blue oxidation) indicating an overheating condition caused by insufficient cooling water/air. Overheating of blades may lead to loss of core tension and/or increase the possibility for blade failure. Check to make sure the steel core's width is uniform about the rim of the blade, and not succumbing to an "under cutting" condition brought about by highly abrasive material or improper under cutting core protection.
4. **Directional Arrow** – Check to ensure that the blade is oriented properly on the blade shaft for sawing. Reference the directional arrow in the blade and place it so the direction of rotation "downcuts" with the turn of the shaft.
5. **Diamond Segment or Rim** – Ensure there are no cracks, dings, or missing portions of the diamond segment/rim. **DO NOT use a blade that is missing a segment or a portion of the rim.** Damaged and/or missing segments/rims may cause damage to your saw, and injury to the user or others in the operating area.
6. **Specifications** – Ensure that the blade specifications, size, and diameter properly match up to the sawing operation. Utilizing a diamond blade not matched properly to the task may result in poor performance and/or blade damage.
7. **Arbor Hole** – It is essential that the arbor hole diameter properly matches the blade, and that it is free from distortions. Correct blade flanges (collars) must be used. The inside face of the flanges must be clean & free of debris. An out of round arbor condition will cause damage to the blade and the saw.
8. **MAX RPM** – This RPM reference is the maximum safe operating speed for the blade selected. **DO NOT** use blades rated at a lower rotational speed than the rated RPM of the saw (6000 RPM). Exceeding the MAX RPM is dangerous, and may cause poor performance and may damage the blade. All blades must be designed to meet or exceed the maximum spindle RPM.

FCG1 CONCRETE SAW — BLADE PLACEMENT

Table 4. Material Listing And Blade Selection

Material	Blade
Cured Concrete	Cured Concrete Blade
Green Concrete	Green Concrete Blade
Asphalt	Asphalt Blade
Asphalt over Concrete	Asphalt/Concrete Blade
Block, Brick, Masonry, Refractories	Masonry Blade
Tile, Ceramic, Stone	Tile Blade

Diamond Blades

Selecting the diamond blade **TYPE** and **GRADE** defines how the blade will perform both in cutting speed and blade life.

Selection of the proper diamond blade consists of:

- Material to be Cut
- Type of Saw Being Used
- Spindle Speed of Saw
- Hardness Characteristics of the Material
- Performance Expectations

Factors for sawing economy:

- Type of Blade
- Depth of Cut
- Sawing Speed
- Characteristics of the Material Being Cut

Blade Speed

A diamond blade's performance is directly connected to specific peripheral (rim) speeds.

The following shaft rotational speeds have been factory set to ensure optimum blade performance.

- FCG1 - 10" (254 mm) Capacity - 6000 RPM.

WARNING

Operating saw blades at rotational speeds greater than those specified by the manufacturer can cause blade damage, and may injure the user or others in the operating area.

Cutting Depth

The FCG1 Concrete Saw has a capacity for a 10" blade with an 0.75" (19.1 mm) Arbor diameter. This allows a cutting range from 0" to 3 1/4".

BLADE PLACEMENT

WARNING

Failure to thoroughly inspect the diamond blade for operational safety could result in damage to the blades or the saw and may cause injury to the user or others in the operating area.

Refer to Figure 12 for the following components.

1. **Blade Guard** - Pivot the blade guard front cover all the way back. The guard tension spring will keep the front cover in position.
2. **Blade Hex Nut** - Unscrew the blade shaft nut (right side loosens clockwise and tightens counter-clockwise while the left side loosens counter-clockwise and tightens clockwise. **DO NOT** overtighten the nut (approximately 45-50 ft. lb/61-68 N/m) when finalizing the assembly.
3. **Outside Blade Flange (Collar)** - Ensure that the outside blade flange is placed flush against the diamond blade. The inside surface of the flange must be free of debris and permit a tight closure on the surface of the blade core.

FCG1 CONCRETE SAW — BLADE PLACEMENT

4. **Diamond Blade** - Ensure that the proper diamond blade has been selected for the job. Pay close attention to the directional arrows on the blade. The blade's operating directional arrows must point in a "down-cutting" direction to perform correctly. When placing the blade onto the blade shaft, ensure the arbor hole of the blade matches the diameter of the shaft.

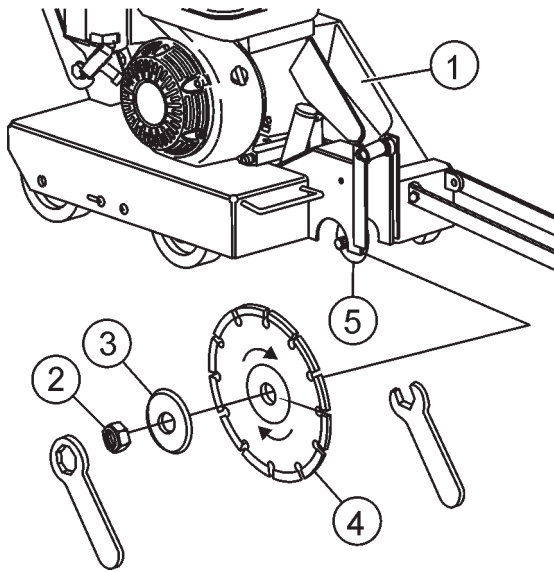
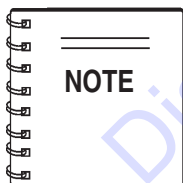



Figure 12. Diamond Blade Placement

5. **Inner Flange (Collar)** - This flange is fixed upon the blade shaft. The inside surface of the flange must be free of debris and permit a tight closure on the surface of the blade.



The following steps should be accomplished before using the FCG1 Saw on any cutting surface.



WARNING

Dropping or forcing the blade onto the cutting surface can severely damage the diamond blade and may cause serious damage to the saw and bodily harm.



Blade Removal and Replacement

1. Ensure the Engine Shutdown switch (Item 22, Fig.3) and the ON/OFF switch on the engine are turned to the "OFF" position. 
2. Place the FCG1 Saw on a stable level working surface.
3. Ensure the blade is raised and the raise/lower rod is locked into position.
4. Raise the blade by applying a downward pressure on the handlebars to raise the blade and allow the raise/lower rod to drop into the "raised-position" slot.

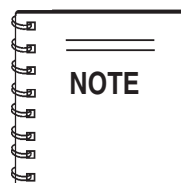

When removing or installing a diamond blade, please note that the blade retaining nuts are left and right-hand threaded.

5. Lift up the blade guard cover (item 1 Figure 12) to gain access to the diamond blade.
6. Use the provided blade nut and blade shaft locking wrenches (Figure 12) to install the diamond blade.
7. While holding the blade shaft with the locking wrench, remove the blade hex nut (clockwise direction) and outer blade flange.
8. Remove the old blade and install a new blade in the same rotational direction as marked on the blade.
9. Reinstall the outer blade flange and hex nut. Tighten the nut firmly (counter-clockwise direction). **DO NOT OVER TIGHTEN.**

FCG1 CONCRETE SAW — BLADE PLACEMENT

Cutting Depth Adjustment

The FCG1 Saw is equipped with a Raise/Lower Assembly that is supported by the following components (Figure 13).

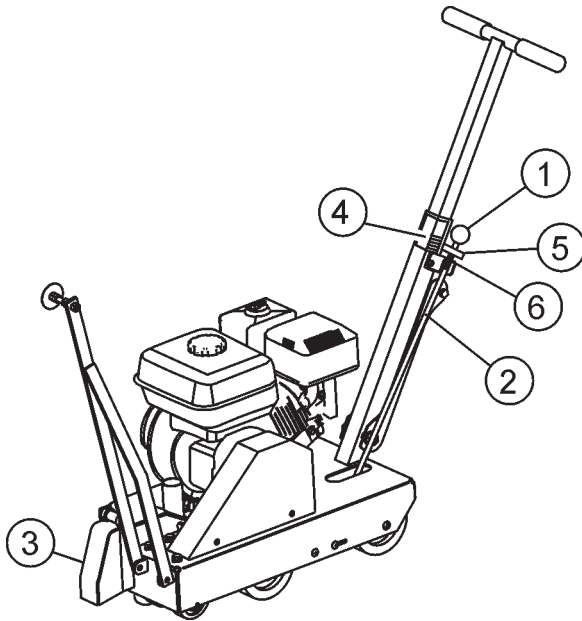

Figure 13. Raise/Lower Assembly

- (1) Shift Knob
- (2) Depth Stop Rod
- (3) Blade Guard
- (4) Depth Control Indicator
- (5) Depth Adjust Disk
- (6) Screw Plunger

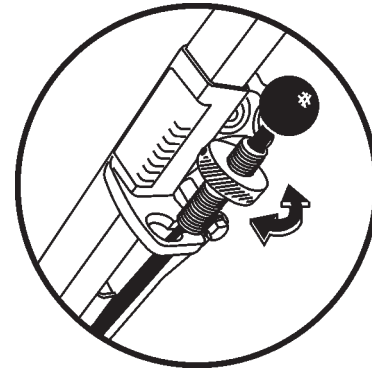
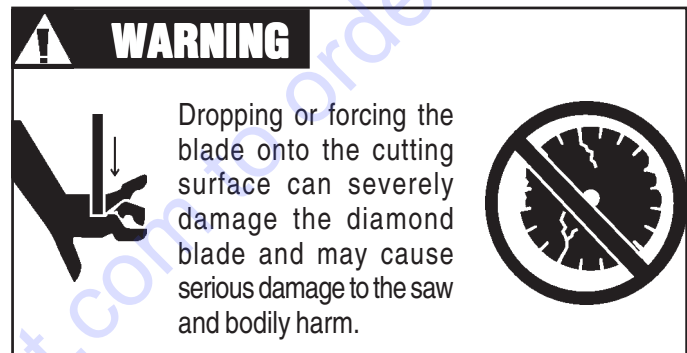

Figure 14. Raise/Lower Adjustment Wheel



To adjust the blade to the desired cutting depth, perform the following steps:

1. Mount the desired diamond blade on the shaft and secure as instructed in the Blade Removal and Replacement section.
2. While holding the handle bars to support the weight of the saw, grasp the knob of the Depth Stop Rod and move it forward out of its keyhole slot. (Figure 14)
3. Gently allow the blade to contact the surface.
4. Rotate the Depth Stop Disk about the Screw Plunger and line up the **bottom edge** of the Depth Stop Disk across from desired depth line mark.. **THIS LINE MARK WILL COINCIDE WITH THE BLADE CUTTING DEPTH REGARDLESS OF BLADE DIAMETER USED.**
5. Press down on the handlebars again to lift the blade until the Depth Stop Rod drops into the back portion of the keyhole slot.
6. You are ready to start cutting. Refer to the following pre-inspection and operation sections.
7. Test the depth of cut by cutting a short distance, then measure the depth of the cut.

WARNING

ALWAYS be certain the Shutdown switch and the engine ON/OFF switch are in the "OFF" position and the blade shaft has **COMPLETELY STOPPED ROTATING** before performing the following operations.

FCG1 CONCRETE SAW — INSPECTION — PRE-INSPECTION

Before Starting

1. Read safety instructions at the beginning of manual.
2. Clean the **saw**, removing dirt and dust, particularly the engine cooling air inlet, carburetor and air cleaner.
3. Check the air filter for dirt and dust. If air filter is dirty, replace air filter with a new one as required.
4. Check carburetor for external dirt and dust. Clean with dry compressed air.
5. Check fastening nuts and bolts for tightness.

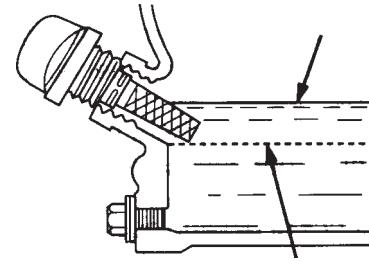

Figure 16. Engine Oil Dipstick (Oil Level)

Engine Oil Check

1. To check the engine oil level, place the saw on secure level ground with the engine stopped. The frame platform **must be level** to accurately check the engine oil.
2. Remove the filler dipstick from the engine oil filler hole (Figure 15) and wipe it clean.

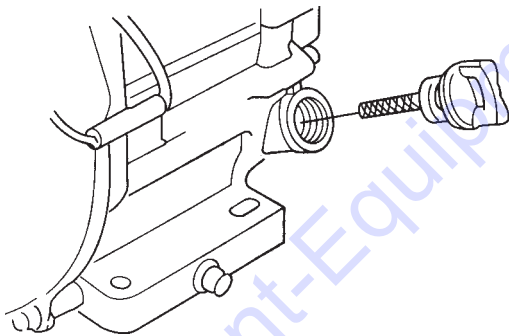
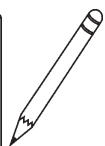
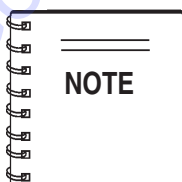

Figure 15. Engine Oil Dipstick (Removal)

3. Insert and remove the dipstick without screwing it into the filler neck. Check the oil level shown on the dipstick.
4. If the oil level is low (Figure 16), fill to the edge of the oil filler hole with the recommended oil type (Table 5).



Reference manufacturer engine manual for specific servicing instructions.

Table 5. Oil Type

Season	Temperature	Oil Type
Summer	25°C or Higher	SAE 10W-30
Spring/Fall	25°C~10°C	SAE 10W-30/20
Winter	0°C or Lower	SAE 10W-10

! WARNING

Motor fuels are highly flammable and can be dangerous if mishandled. **DO NOT** smoke while refueling. **DO NOT** attempt to refuel the saw if the engine is **hot** or **running**.

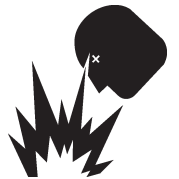

1. Remove the gasoline cap located on top of fuel tank.
2. Visually inspect to see if fuel level is low. If fuel is low, replenish with unleaded fuel.
3. When refueling, be sure to use a strainer for filtration. **DO NOT** top-off fuel. Wipe up any spilled fuel.

V-belt Check

A worn or damaged V-belt can adversely affect the performance of the trowel. If a V-belt is defective or worn, replace the V-belt as outlined on page 18.

Blade Check

Check for worn or damaged blades. Refer to BLADE PLACEMENT section on pages 20-22.

FCG1 CONCRETE SAW — OPERATION

OPERATION

CAUTION

DO NOT attempt to operate the saw until this manual has been read and thoroughly understood. Engine operating steps may vary. See included engine manufacturer's operating manual.



WARNING

When the engine is running the cutting blade is **ALWAYS rotating**. Keep hands and feet clear of rotating blade. Raise the saw to full height when maneuvering the saw within the cutting area.



All displacement of the machine outside the cutting area shall be carried out with the tool not in rotation.

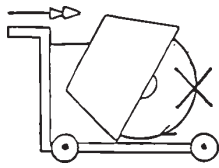

WARNING

NEVER place hands or feet inside the belt guard or blade guard while the engine is running. **ALWAYS** shut the engine down before performing any kind of maintenance service on the saw.



CAUTION

Ensure the work area is clear of tools, debris, and unauthorized people.

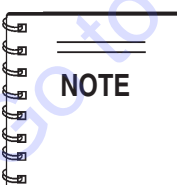

NOTE

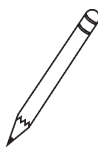

The saw is equipped with an outlet that provides a connection to a dust collection bag or vacuum system, (Item 23, Fig. 3). It is recommended that a dust collection bag or vacuum system is used while the saw is in operation.

1. Ensure the engine **Shutdown switch** and the engine **ON/OFF switch** on the engine are both in the **OFF** position to avoid accidental starting.

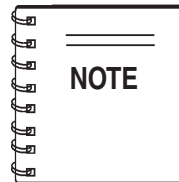

NOTE

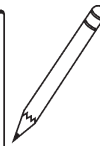

The **Engine Stop Switch** serves both as an **Emergency Engine Shut-Off** and as the **primary Shutdown switch**. This allows the operator to shutdown the saw safely away from moving parts.

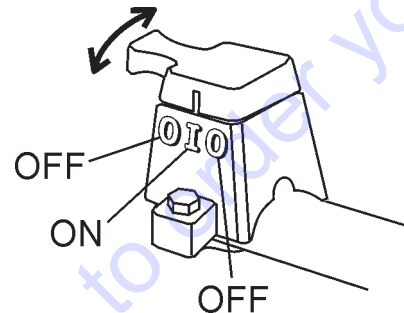

Figure 17. Engine Shutdown Switch

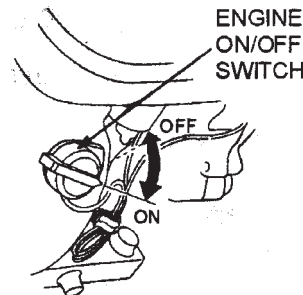

Figure 18. Engine ON/OFF Switch

2. Place the **fuel valve lever** (Figure 19) to the "ON" position.

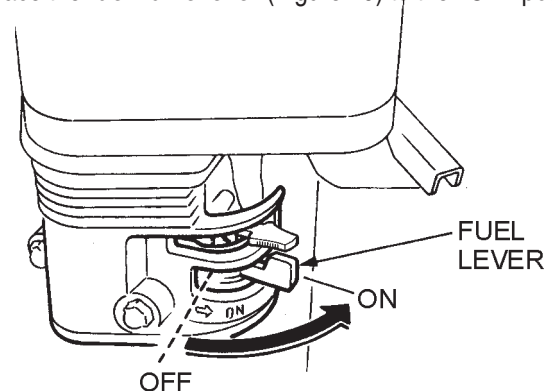
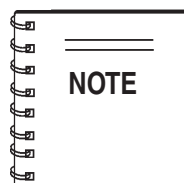

Figure 19. Engine Fuel Valve Lever

FCG1 CONCRETE SAW — OPERATION

- Place the engine **Shutdown switch** (next to the handle lock), and the engine **ON/OFF switch** on the engine to the "**ON**" position. Shutting the engine off using this switch confirms that it is functioning properly.



Always use the Engine Shutdown Safety Switch located next to the handle lock to shut down the engine. Shutting the engine off using this switch confirms that it is functioning properly.

- Place the **Choke Lever** (Figure 20) in the "**CLOSED**" position.

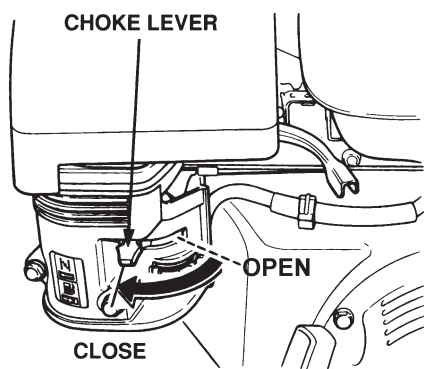

Figure 20. Choke Lever

CAUTION

The engine speed has been set at the factory. Changing the governor speed could damage the blade and/or the saw.



- Rotate the **throttle lever** (Figure 21) halfway between **fast** and **slow** for starting. All sawing is done at **full throttle**. The engine governor speed is factory set to ensure optimum blade operating speeds.

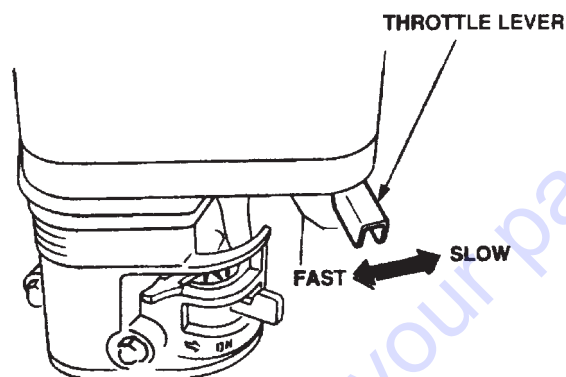

Figure 21. Throttle Lever

- Grasp the starter grip (Figure 22) and slowly pull it out. The resistance becomes the hardest at a certain position, corresponding to the compression point. Pull the starter grip briskly and smoothly for starting.

CAUTION

DO NOT pull the starter rope all the way to the end. DO NOT release the starter rope after pulling. Allow it to rewind as soon as possible.

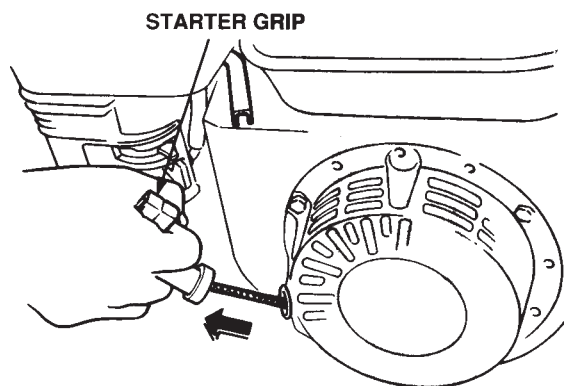

Figure 22. Starter Grip

FCG1 CONCRETE SAW — OPERATION

7. If the engine has started, slowly return the choke lever (Figure 20) to the "**OPEN**" position. If the engine has not started repeat steps 1 through 5.
8. Before the saw is placed into operation, run the engine for several minutes. Check for fuel leaks, and noises that would associate with a loose guards and/or covers.
9. Rotate the throttle lever (Figure 21) toward full throttle.

WARNING

ALWAYS cut with the saw at **FULL THROTTLE**. Attempting to cut with the saw at less than full throttle could cause the blade to bind or stop abruptly in the slab resulting in serious injury to the operator or others in the area.

WARNING

ALWAYS keep clear of **rotating** or **moving** parts while operating this equipment.

10. To begin sawing, lower the rotating blade allowing it to cut to the preset depth.
11. When blade has reached full cutting depth, slowly walk behind the saw at a rate that will allow the engine to operate without losing optimum RPM.

CAUTION

DO NOT try to cut faster than the blade will allow. Cutting too fast will cause the blade to rise up out of the cut. Improper cutting rate can decrease the life of the engine and blades.

12. When the end of the cut has been reached, raise the blade out of the cut by pulling back on the handlebars (using a downward pressure) until the raise/lower rod drops into its slot with the blade in the raised position.
13. If cutting is complete, shut the saw down using the following "Shutdown Procedures".

Stopping the Engine

Stopping the engine under normal conditions:

1. Place the **engine throttle lever** (Figure 23) in the **SLOW** position, and listen for the engine speed to decrease. Allow engine to run for 2 or 3 minutes for proper cooldown.

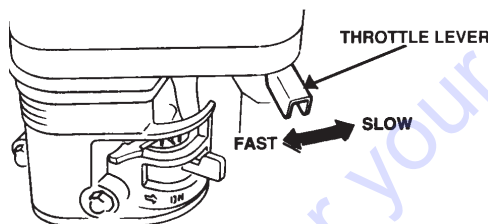

Figure 23. Throttle Lever

2. Turn the **engine Shutdown switch** (next to the handle lock) (Figure 24) to the "**OFF**" position. Shutting the engine off using this switch confirms that it is functioning properly.

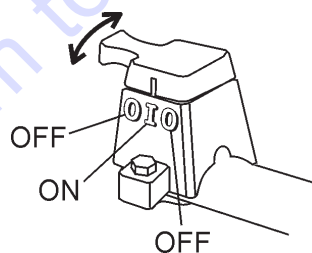

Figure 24. Engine Shutdown Switch

3. Turn the **engine ON/OFF switch** (Figure 25) to the "**OFF**" position.

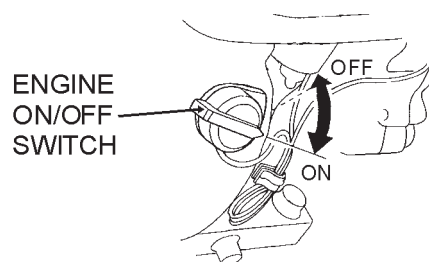

Figure 25. Engine ON/Off Switch (engine)

4. Place the fuel valve lever (Figure 26) to the **OFF** position.

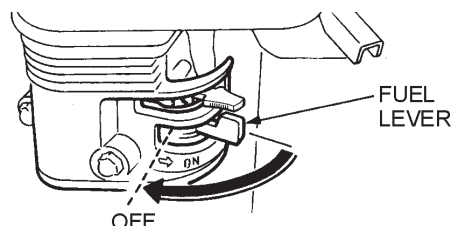

Figure 26. Fuel Valve Lever (Off Position)

Restarting After Intervention

If cutting is interrupted where the engine stops or is turned off while the blade is still in the cut:

- a. Turn engine Shutdown switch (next to the handle lock) to the "OFF" position.
- b. Raise the blade out of the cut
- c. Restart the engine as described in the Start-Up sections on page 24.



CAUTION

The only acceptable method for freeing a stuck blade is to remove the saw from the stuck or pinched blade. **DO NOT** try to get the blade unstuck using the Raise/Lower system or by lifting the saw by the lifting bale, etc.

If cutting is interrupted where the blade is stuck in the cut:

- a. Turn engine Shutdown switch (next to the handle lock) to the "OFF" position.
- b. Remove the blade guard.
- c. Remove blade mounting bolt and outer flange.
- d. Maneuver the saw away from the stuck blade.
- e. A parallel cut made next to the blade may be necessary to free it.
- f. Once the blade is freed inspect the blade for damage; discard if damaged.
- e. Ensure an undamaged, useable blade is installed on the saw before cutting is resumed with that saw.

FCG1 CONCRETE SAW — MAINTENANCE

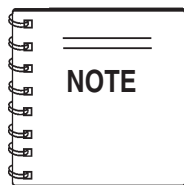

See the engine manual supplied with your machine for appropriate engine maintenance schedule and troubleshooting guide for problems.

CAUTION

ALWAYS allow the engine to cool before servicing. **NEVER** attempt any maintenance work on a **hot!** engine.



WARNING

ALWAYS ensure that the engine ON/OFF switch is in the "OFF" position and that the arbor shaft has **COMPLETELY STOPPED ROTATING** before performing any of the the following operations:



- **REMOVING** or **INSTALLING** blades
- **ADJUSTING** front or rear pointers
- **LUBRICATING** any components
- **REMOVING** engine mounting bolts
- **INSPECTING, ADJUSTING, OR REPLACING** drive belt, arbor shaft, arbor shaft bearings or **ANY** engine part



3. Adjust the front pointer so it just touches the side of the straight-edge or level.
4. Remove the straight-edge or level.
5. Position the front pointer and blade directly over the chalk line.
6. Start the saw and lower the blade onto the chalk line.
7. Begin cutting and make sure the blade follows the chalk line as closely as possible.
8. The pointer should follow the chalk line as well. If it does not, adjust the pointer by loosening then tightening the jam nuts on the pointer until the pointer follows the same path as the blade.

Rear Guide Adjustment

The rear guide is useful on long runs that allow the operator to follow the line with less effort as well as cutting up to a wall where the front pointer is lifted.

1. Chalk out a straight line on the prepared slab or cutting surface.
2. Cut a straight line about 10 - 12 feet (3 - 4 meters) in length.
3. Adjust the rear guide until it falls into the cut.
4. The rear guide should ride in the cut freely without the feel of it pushing the front pointer or blade off line. If it feels like it is doing so, turn the saw off and after the blade has **COMPLETELY STOPPED ROTATING**, adjust the rear guide by loosening then tightening the jam nuts on the guide until it rides freely in the cut.

Saw Blade Removal and Installation

Saw blade removal and installation is covered on pages 21.

Front Pointer Adjustment

The front pointer and rear guide have been set at the factory. Use these procedures only if the pointer or guide are suspect of being out of alignment.

1. Chalk out a straight line on the prepared slab or cutting surface.
2. Use a 4 foot straight-edge or level by placing it flat against the blade.

General Engine Care

Engine check:

Check daily for any oil and/or fuel leakage, thread nut & bolt tightness, and overall cleanliness.

Engine oil:

Check daily. Inspect with blade removed and saw frame level on a level surface. Keep the oil clean, and at the proper servicing level (Figure 8). **DO NOT OVERFILL!** SAE 10W-30 of SG is recommended for general use.

Engine oil change:

Change engine oil after the first month or 20 hours of operation, then every 3 months/or 50 HOURS of operation. See Engine Owner's Manual for detailed information.

FCG1 CONCRETE SAW — MAINTENANCE

Engine tank & strainer:

Clean every year/or 300 hours.

Fuel line:

Replace every two years/or as necessary.

Spark plug:

Clean/adjust every 6 months/or 100 hours. Replace every year/ or 300 hours.

Chassis Lubrication

Regular lubrication of various components of the FCG1 Saw are critical to ensure a reasonable service life. Lubricate the following components:

Drive Belt

Refer to pages 17 to 18 of this manual for Drive Belt adjustment procedures and Removal and Replacement procedures.

Blade Shaft Bearings

Two zerk fittings are located at the lower-front area of the saw. Lubricate before daily use. Use a good quality automotive or general purpose grease. Check and lubricate more often if unit is under heavy use. Do not overfill bearings. Overfilling can damage the grease seals which can result in bearing exposure to dirt and contaminants which can then shorten the life of the bearings. Excess grease can also drip onto the cutting surface.

Engine Oil Change

Drain the used oil while the engine is warm by the following:

Refer to Figure 27.

1. Place an oil pan or suitable container below the engine drain plug to catch the used oil.
2. Remove the filler cap/dipstick and the drain plug.
3. Drain the oil completely and reinstall the drain plug. Ensure the drain plug is tightened securely.

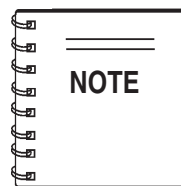

Dispose of used oil properly. **DO NOT** pour used oil on the ground, down a drain, or throw in the trash. Used oil can generally be taken to your local recycling center or service station for reclamation.

4. Make sure the engine is in a level position and fill to the outer edge of the oil filler hole with the recommended oil. (See Table 5.) Engine oil capacity is 0.63 US quart (0.60 liter).

CAUTION

Running the engine with a low oil level can cause engine damage.

5. Screw in the filler cap/dipstick securely.

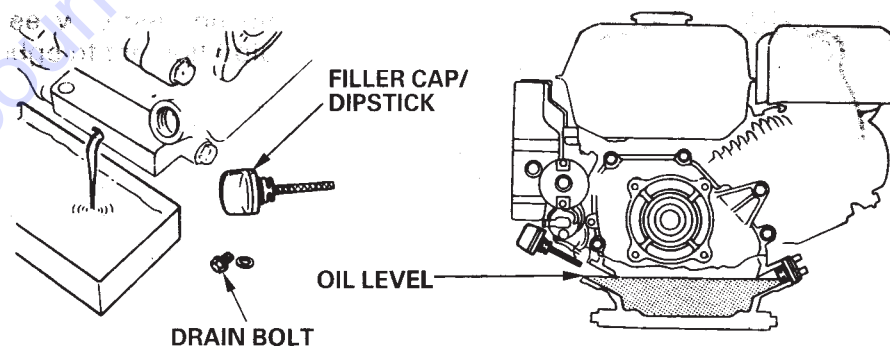

Figure 27. Engine Oil Change

FCG1 CONCRETE SAW — TROUBLESHOOTING (SAW)

TABLE 6. BLADE TROUBLESHOOTING

SYMPTOM	POSSIBLE PROBLEM	SOLUTION
Blade slows or stops cutting, still remains on blade	Blade too hard for the material being cut?	Consult Discount-equipment for correct blade. Try cutting very soft material (sandstone, silica brick, cinder block) to "Redress" the blade.
	Engine torque diminished because of loose V-belt?	Tighten and/or replace V-Belt.
	Insufficient Engine power?	Check throttle setting. Check Engine horsepower.
	Improper direction of rotation?	Check that the blade is properly oriented and rotational arrow points in a "Down-Cutting" direction.
	Blade is slipping on the blade shaft?	Check that the blade & flange pin are properly installed on the blade shaft.
Blade does not cut straight and/or true.	Blade being used on misaligned saw?	Check blade shaft bearings and alignment integrity.
	Blade is excessively hard for the material being cut?	Check specification of the blade with the material being cut. Consult Discount-equipment for information.
	Blade being used at improper RPM?	Ensure blade surface feet per minute speed (SFPM) is approximately 6,000.
	Blade improperly mounted on arbor shoulders and flanges?	Ensure blade is properly affixed on the blade shaft.
	Excessive force applied to blade while cutting?	DO NOT force the blade in the cut. Apply a slow and steady pace when sawing.
Blade discoloring, crackling and/or wearing excessively.	Blades too hard for the material being cut?	Consult Discount-equipment for correct blade. Try cutting very soft material (sandstone, silica brick, cinder block) to "Redress" the blade.
	Blade improperly mounted on arbor shoulders and flanges??	Ensure blade is properly affixed on the blade shaft.
	Blade not receiving enough cooling air?	Ensure proper flow & volume of water is provided for wet cutting blades. Ensure sufficient cooling air is circulated about a dry cutting blade.
	Arbor hole out of round?	Ensure blade is properly affixed on the blade shaft.
	Incorrect blade chosen for material being cut?	Check specification of the blade with the material being cut. Consult Discount-equipment for information.
	Excessive force applied to blade while cutting?	DO NOT force the blade in the cut. Apply a slow and steady pace when sawing.

FCG1 CONCRETE SAW — TROUBLESHOOTING (ENGINE)

TABLE 7. TROUBLESHOOTING (ENGINE)

SYMPTOM	POSSIBLE CAUSE	SOLUTION
Difficult to start, "fuel is available, but no SPARK at spark plug".	Spark plug bridging?	Check gap, insulation or replace spark plug.
	Carbon deposit on spark plug?	Clean or replace spark plug.
	Short circuit due to deficient spark plug insulation?	Check spark plug insulation, replace if worn.
	Improper spark plug gap?	Set to proper gap.
Difficult to start, "fuel is available, and SPARK is present at the spark plug".	ON/OFF switch is shorted?	Check switch wiring, replace switch.
	Ignition coil defective?	Replace ignition coil.
	Improper spark gap, points dirty?	Set correct spark gap and clean points.
	Condenser insulation worn or short circuiting?	Replace condenser.
	Spark plug wire broken or short circuiting?	Replace defective spark plug wiring.
Difficult to start, "fuel is available, spark is present and compression is normal".	Wrong fuel type?	Flush fuel system, and replace with correct type of fuel.
	Water or dust in fuel system?	Flush fuel system.
	Air cleaner dirty?	Clean or replace air cleaner.
	Choke Open?	Close Choke.
Difficult to start, "fuel is available, spark is present and compression is low".	Suction/exhaust valve stuck or protruded?	Re-seat valves.
	Piston ring and/or cylinder worn?	Replace piston rings and or piston.
	Cylinder head and/or spark plug not tightened properly?	Torque cylinder head bolts and spark plug.
	Head gasket and/or spark plug gasket damaged?	Replace head and spark plug gaskets.
No fuel present at the carburetor.	Fuel not available in fuel tank?	Fill with correct type of fuel.
	Fuel filter clogged?	Replace fuel filter.
	Fuel tank cap breather hole clogged?	Clean or replace fuel tank cap.
	Air in fuel line?	Bleed fuel line.

FCG1 CONCRETE SAW — TROUBLESHOOTING (ENGINE)

TABLE 7. TROUBLESHOOTING (ENGINE, CONTINUED)

SYMPTOM	POSSIBLE CAUSE	SOLUTION
"Weak in power" compression is proper and does not misfire.	Air cleaner not clean?	Clean or replace air cleaner.
	Improper level in carburetor?	Check float adjustment.
		Rebuild carburetor.
	Defective spark plug?	Clean or replace spark plug.
Improper spark plug gap?	Set to proper gap.	
"Weak in power" compression is proper but misfires.	Water in fuel system?	Flush fuel system and replace with correct type fuel.
	Ignition coil defective?	Replace ignition coil.
	Dirty spark plug?	Clean or replace spark plug.
Engine overheats.	Wrong fuel type?	Flush fuel system, and replace with correct type of fuel.
	Spark plug heat value improper?	Replace with correct type of spark plug.
	Cooling fins dirty?	Clean cooling fins.
Rotational speed fluctuates.	Governor adjusted correctly?	Adjust governor.
	Governor spring defective or missing?	Replace governor spring.
	Fuel flow restricted?	Check entire fuel system for leaks or clogs.
Recoil starter malfunction.	Recoil mechanism clogged with dust and dirt?	Clean recoil assembly with soap and water.
	Spiral spring loose?	Replace spiral spring.

EXPLANATION OF CODE IN REMARKS COLUMN

The following section explains the different symbols and remarks used in the Parts section of this manual. Use the help numbers found on the back page of the manual if there are any questions.

NOTICE

The contents and part numbers listed in the parts section are subject to change **without notice**. Multiquip does not guarantee the availability of the parts listed.

SAMPLE PARTS LIST

NO.	PART NO.	PART NAME	QTY.	REMARKS
1	12345	BOLT.....	1	INCLUDES ITEMS W/%
2%		WASHER, 1/4 IN.....		NOT SOLD SEPARATELY
2%	12347	WASHER, 3/8 IN....	1	MQ-45T ONLY
3	12348	HOSE	A/R	MAKE LOCALLY
4	12349	BEARING	1	S/N 2345B AND ABOVE

NO. Column

Unique Symbols — All items with same unique symbol

(@, #, +, %, or >) in the number column belong to the same assembly or kit, which is indicated by a note in the “Remarks” column.

Duplicate Item Numbers — Duplicate numbers indicate multiple part numbers, which are in effect for the same general item, such as different size saw blade guards in use or a part that has been updated on newer versions of the same machine.

NOTICE

When ordering a part that has more than one item number listed, check the remarks column for help in determining the proper part to order.

PART NO. Column

Numbers Used — Part numbers can be indicated by a number, a blank entry, or TBD.

TBD (To Be Determined) is generally used to show a part that has not been assigned a formal part number at the time of publication.

A blank entry generally indicates that the item is not sold separately or is not sold by Multiquip. Other entries will be clarified in the “Remarks” Column.

QTY. Column

Numbers Used — Item quantity can be indicated by a number, a blank entry, or A/R.

A/R (As Required) is generally used for hoses or other parts that are sold in bulk and cut to length.

A blank entry generally indicates that the item is not sold separately. Other entries will be clarified in the “Remarks” Column.

REMARKS Column

Some of the most common notes found in the “Remarks” Column are listed below. Other additional notes needed to describe the item can also be shown.

Assembly/Kit — All items on the parts list with the same unique symbol will be included when this item is purchased.

Indicated by:

“INCLUDES ITEMS W/(unique symbol)”

Serial Number Break — Used to list an effective serial number range where a particular part is used.

Indicated by:

“S/N XXXXX AND BELOW”

“S/N XXXX AND ABOVE”

“S/N XXXX TO S/N XXX”

Specific Model Number Use — Indicates that the part is used only with the specific model number or model number variant listed. It can also be used to show a part is NOT used on a specific model or model number variant.

Indicated by:

“XXXXX ONLY”

“NOT USED ON XXXX”

“Make/Obtain Locally” — Indicates that the part can be purchased at any hardware shop or made out of available items. Examples include battery cables, shims, and certain washers and nuts.

“Not Sold Separately” — Indicates that an item cannot be purchased as a separate item and is either part of an assembly/kit that can be purchased, or is not available for sale through Multiquip.

FCG1 CONCRETE SAW— SUGGESTED SPARE PARTS

FCG1 CONCRETE SAW 1 TO 3 UNITS WITH HONDA GX200QXC9 ENGINE

1 to 3 Units

Qty.....	P/N.....	Description
3	16052	BELT
2	25407	WHEELS
2	15028	COLLARS, WHEEL
2	15081	GRIP, HANDLE
1	25380	BLADE, SHAFT/FLANGE
2	15359	BEARING, PILLOW BLOCK
1	19710	NUT, BLADE
3	17210ZE1505	AIR FILTER
3	9807956846	SPARK PLUG
1	17620ZH7023	FUEL CAP, TANK
1	28462ZH8003	STARTER ROPE

Go to Discount-Equipment.com to order your parts

FCG1 CONCRETE SAW — DECAL LOCATOR

DECAL LOCATOR

<u>NO.</u>	<u>PART NO.</u>	<u>PART NAME</u>	<u>QTY.</u>	<u>REMARKS</u>
1	25485	DECAL, SLAB SAVER LARGE	1	
2	25482	DECAL, MQ LOGO 3.0 X 3-3/4	2	
3	36099	DECAL, SAFETY CLOTHING ISO BLUE	1	SAFETY ITEM
4	13118	DECAL, POWDER COATED	1	
5		SERIAL NUMBER PLATE	1	
6	25484	DECAL, SLAB SAVER SMALL	1	
7	25427	DECAL, DEPTH INDICATOR	1	
8	20525	DECAL, CA PROP 65	1	SAFETY ITEM
9	15580	DECAL, WARN RESPIRATORY 1-1/2 X 3	1	SAFETY ITEM
10	15581	DECAL, WARN BLADE GUARD 1-1/2 X 3	1	SAFETY ITEM
11	25483	DECAL, MQ LOGO	1	
12	25491	DECAL, BLADE ROTATION CW	1	SAFETY ITEM
13	11246	DECAL, INTL STDS ISO BLACK	1	SAFETY ITEM
14	25867	DECAL, ROTATION IN DISPLACEMENT	1	SAFETY ITEM
15	35137	DECAL, READ MANUAL	1	SAFETY ITEM

Go to Discount-Equipment.com to order your parts

FCG1 CONCRETE SAW — GUARDS ASSY.

GUARDS ASSY.

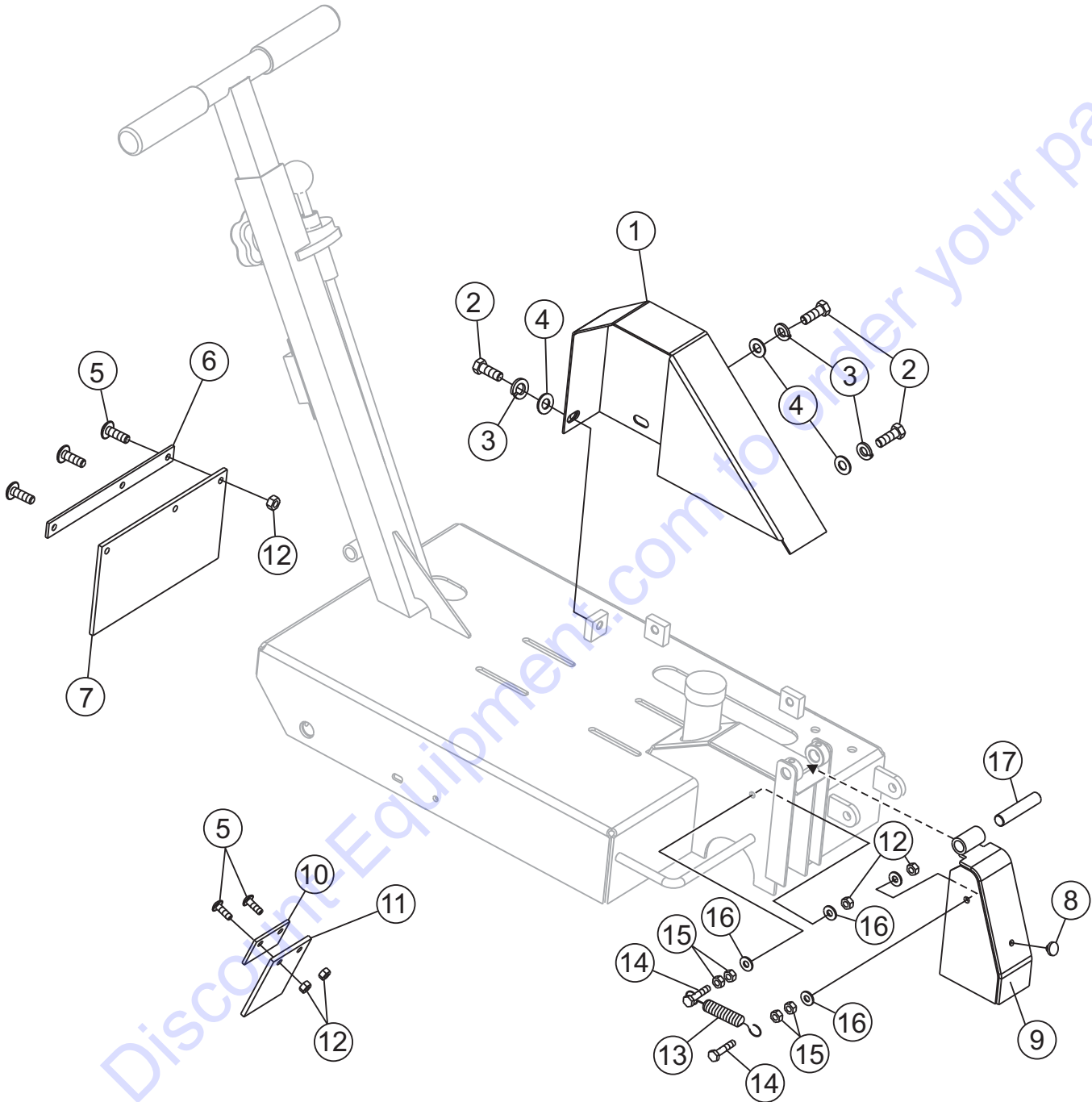

FCG1 CONCRETE SAW — GUARDS ASSY

GUARDS ASSY.

<u>NO.</u>	<u>PART NO.</u>	<u>PART NAME</u>	<u>QTY.</u>	<u>REMARKS</u>
1	25387	GUARD, BELT	1	SAFETY ITEM
2	4196	SCREW, HHC 3/8 - 16 X 0.75	3	
3	0166 A	WASHER, LOCK 3/8 MED	3	
4	10136	WASHER, FLAT 3/8 SAE	3	
5	12287	SCREW, THP 1/4 - 20 X 3/4 SS	3	
6	25430	SHEET, REAR WATER SHIELD	1	SAFETY ITEM
7	25431	FLAP, REAR WATER SHIELD	1	SAFETY ITEM
8	15161	STOP, RUBBER BUMPER	1	
9	25397	GUARD, BLADE 10" DOOR	1	SAFETY ITEM
10	25428	SHEET, FLAP MOUNT	1	SAFETY ITEM
11	25429	FLAP, FRONT WATER SHIELD	1	SAFETY ITEM
12	10024	NUT, NYLOC 1/4 - 20	7	
13	15509	SPRING, CENTURY	1	SAFETY ITEM
14	0424	SCREW, HHC 1/4 - 20 X 1-1/4	2	
15	0949	NUT, HEX FINISH 1/4 - 20	4	
16	0948	WASHER, FLAT 1/4 SA3	8	
17	25401	PIN, HINGE 0.5 X 2.5	1	

FCG1 CONCRETE SAW — GUIDES ASSY.

GUIDES ASSY.

DETAIL A

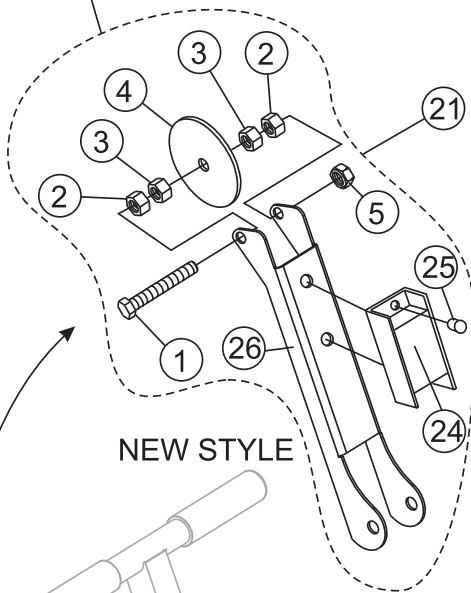

NEW STYLE

DETAIL A

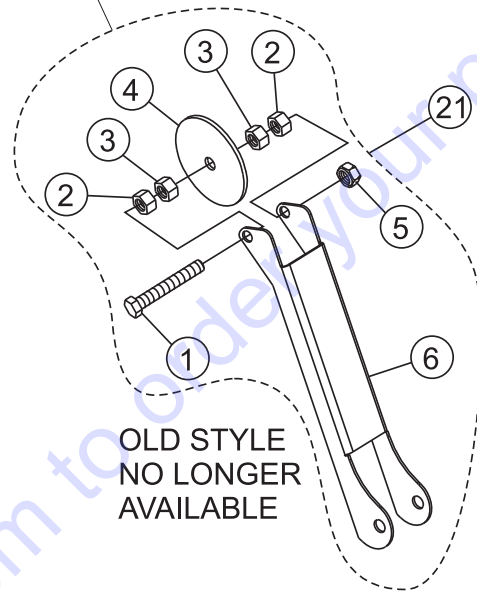

OLD STYLE
NO LONGER
AVAILABLE

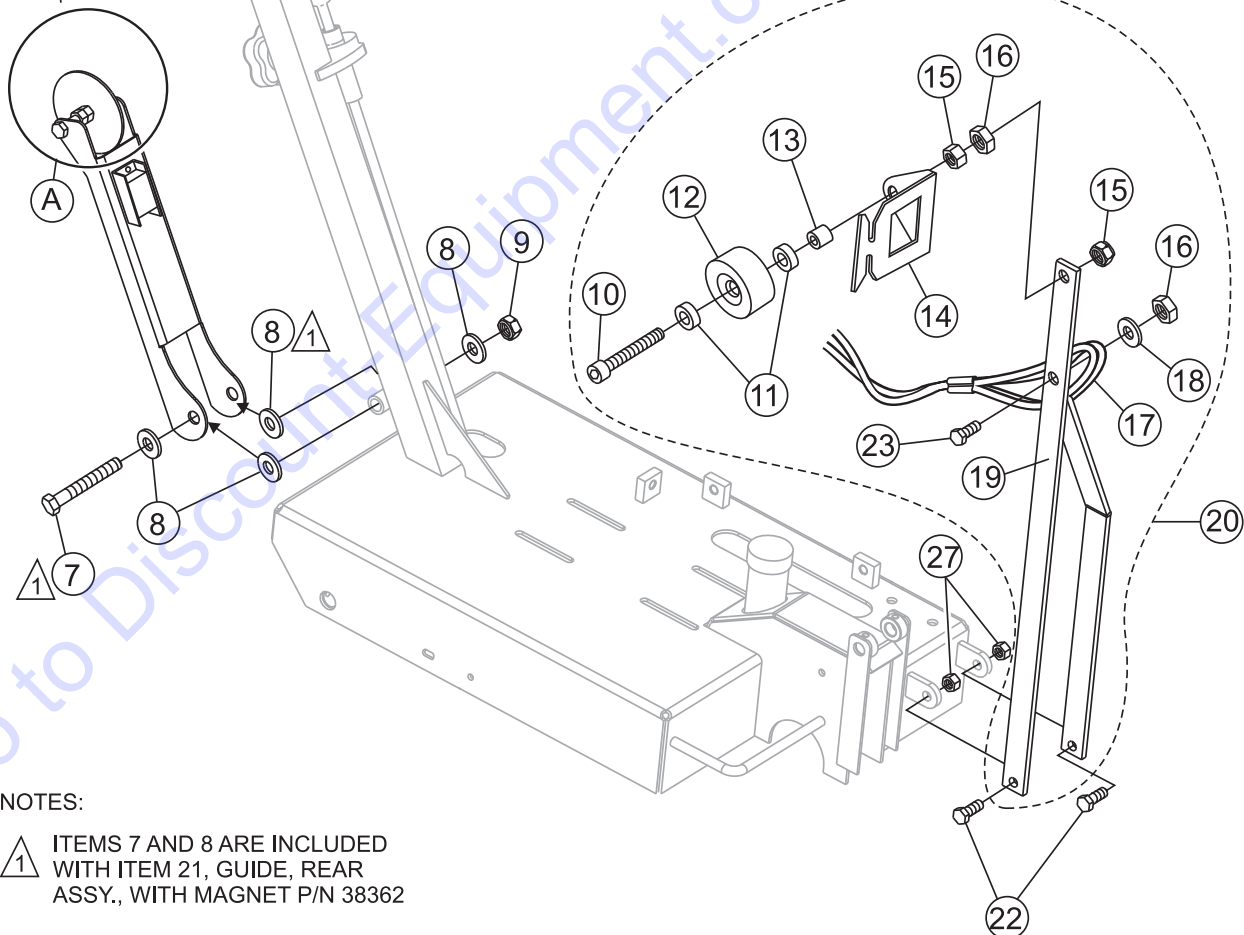

NOTES:

- ① ITEMS 7 AND 8 ARE INCLUDED WITH ITEM 21, GUIDE, REAR ASSY., WITH MAGNET P/N 38362

FCG1 CONCRETE SAW — GUIDESASSY.

GUIDES ASSY.

<u>NO.</u>	<u>PART NO.</u>	<u>PART NAME</u>	<u>QTY.</u>	<u>REMARKS</u>
1#	20473	SCREW, HHC 3/8 - 16 X 3 FULL THRD	1	
2#	1456	NUT, HEX FINISH 3/8 - 16	4	
3#	1007	NUT, HEX JAM 3/8 - 16	4	
4#	25449	WHEEL, GUIDE 3.5 OD X .41 ID FCG	1	
5#	10133	NUT, NYLOC 3/8 - 16	1	
6	25392	SHEET, REAR GUIDE	1	NO LONGER AVAILABLE
7#	3215	SCREW, HHC 1/2 - 13 X 3-1/2	1	
8#	36128	WASHER, NYLON 1/2" ID	4	
9#	10176	NUT, NYLOC 1/2 - 13	1	
10*	35476	SCREW, SHC 5/16-18 X 3.5 FULL THRD	1	
11*	21369	BEARING, SEALED 5/16 ID X 7/8 OD	2	
12*	21189	WHEEL, 2.13 OD X 1.25 W POLYURETHANE	1	
13*	21185	SPACER, 1/2 X 5/16 X 3/8 P33-3	1	
14*	21368	PLATE, POINTER (GUIDE) FCG	1	
15*	5283	NUT, NYLOC 5/16-18	2	
16*	0161 D	NUT, HEX FINISH 5/16-18	2	
17*	35096	SASH ASSY., WIRE ROPE	1	
18*	19470	WASHER, FLAT 5/16 USS	1	
19*	35093	ARM, FRONT POINTER (GUIDE) W/A, FCG	1	
20	35097	POINTER (GUIDE) ASSY., WHEEL STYLE	1	INCLUDES ITEMS W/*
21	25416	GUIDE, REAR ASSY.	1	NO LONGER AVAILABLE
21	38362	GUIDE, REAR ASSY.	1	FEB, 2010
			INCLUDES ITEMS W/#
22*	0205	SCREW, HHC 3/8 - 16 X 1.0	2	
23*	0202	SCREW, HHC 5/16 - 18 X 1 ZINC	1	
24#	38365	MAGNET, FCG REAR ARM	1	
25#	19847	RIVET, POP, ALUM, 3/16X1/8-1/4 GRIP	2	
26#	38366	ARM, REAR POINTER WHEEL	1	
27	10133	NUT, NYLOC 3/8 - 16	2	

PARTS FINDER

**Search Website
by Part Number**



**Search Manual
Library For Parts
Manual & Lookup Part
Numbers – Purchase
or Request Quote**

Search Manuals

Enter your information to help us find the right parts manual for your machine.

* Brand:

* Model:

* Serial:

* Part Number:

SEARCH

**Can't Find Part or
Manual? Request Help
by Manufacturer,
Model & Description**

Parts Order Form

Please fill in the following information to help us find the right part for your machine.

Manufacturer:	<input type="text"/>
Model:	<input type="text"/>
Description:	<input type="text"/>
Part Number:	<input type="text"/>
Quantity:	<input type="text"/>
Notes:	<input type="text"/>

Submit

Discount-Equipment.com is your online resource for quality parts & equipment.

Florida: **561-964-4949** Outside Florida TOLL FREE: **877-690-3101**

Need parts?

Click on this link: <http://www.discount-equipment.com/category/5443-parts/> and choose one of the options to help get the right parts and equipment you are looking for. Please have the machine model and serial number available in order to help us get you the correct parts. If you don't find the part on the website or on one of the online manuals, please fill out the request form and one of our experienced staff members will get back to you with a quote for the right part that your machine needs.

We sell worldwide for the brands: Genie, Terex, JLG, MultiQuip, Mikasa, Essick, Whiteman, Mayco, Toro Stone, Diamond Products, Generac Magnum, Airman, Haulotte, Barreto, Power Blanket, Nifty Lift, Atlas Copco, Chicago Pneumatic, Allmand, Miller Curber, Skyjack, Lull, Skytrak, Tsurumi, Husquvarna Target, Stow, Wacker, Sakai, Mi-T-M, Sullair, Basic, Dynapac, MBW, Weber, Bartell, Bennar Newman, Haulotte, Ditch Runner, Menegotti, Morrison, Contec, Buddy, Crown, Edco, Wyco, Bomag, Laymor, EZ Trench, Bil-Jax, F.S. Curtis, Gehl Pavers, Heli, Honda, ICS/PowerGrit, IHI, Partner, Imer, Clipper, MMD, Koshin, Rice, CH&E, General Equipment, Amida, Coleman, NAC, Gradall, Square Shooter, Kent, Stanley, Tamco, Toku, Hatz, Kohler, Robin, Wisconsin, Northrock, Oztec, Toker TK, Rol-Air, APT, Wylie, Ingersoll Rand / Doosan, Innovatech, Con X, Ammann, Mecalac, Makinex, Smith Surface Prep, Small Line, Wanco, Yanmar

FCG1 CONCRETE SAW — UNDERCARRIAGE ASSY.

UNDER CARRIAGE ASSY.

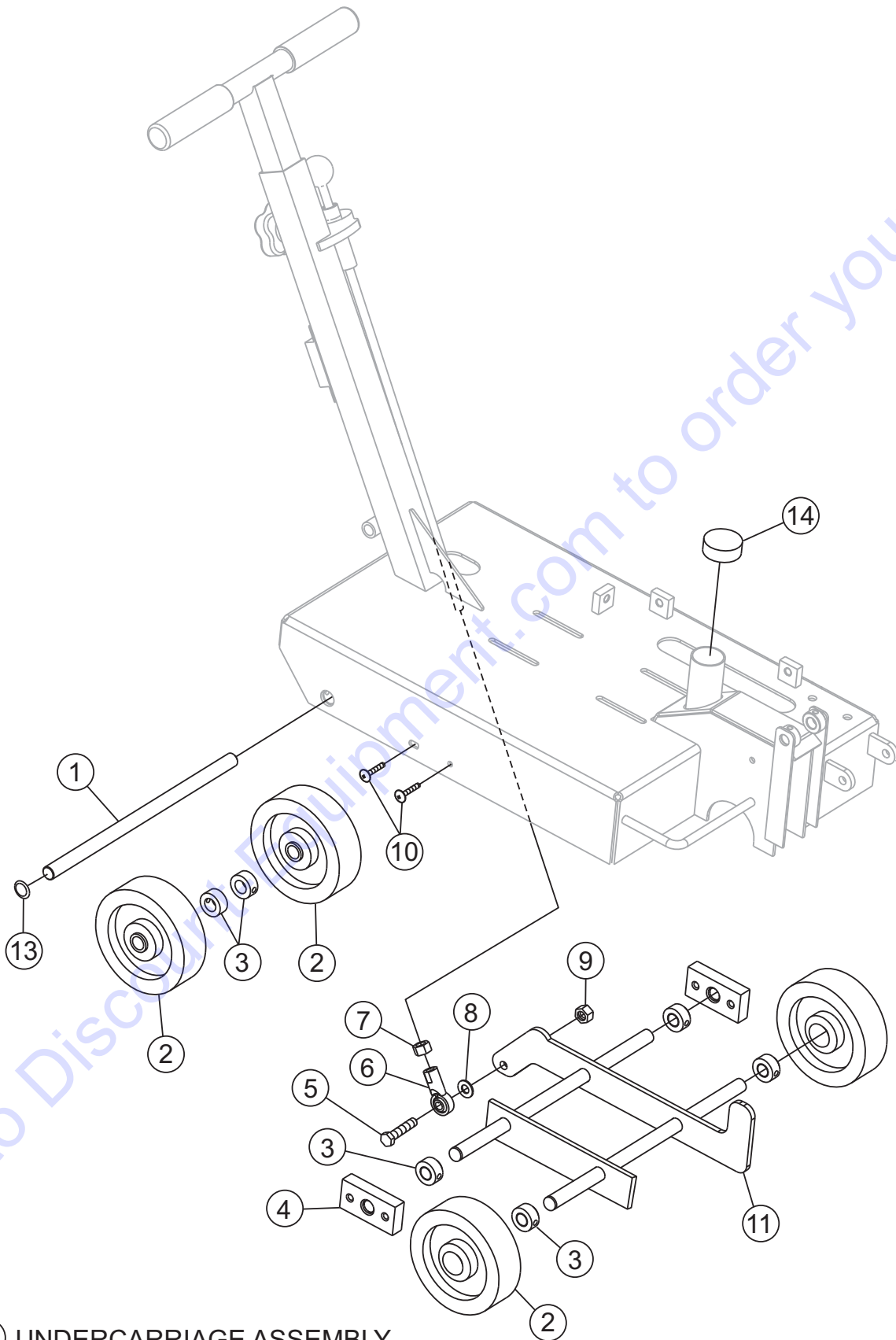

⑫ UNDERCARRIAGE ASSEMBLY

FCG1 CONCRETE SAW — UNDERCARRIAGE ASSY.

UNDER CARRIAGE ASSY.

<u>NO.</u>	<u>PART NO.</u>	<u>PART NAME</u>	<u>QTY.</u>	<u>REMARKS</u>
1	25368	BAR, PIVOT SHAFT	1	
2	25407	WHEEL, 5 X .625 X 1.5 BALL BRG	4	
3	15028	COLLAR, SET 5/8 DIA	4	
4	25379	BEARING, 5/8 FLANGE UHMW	2	
5	9154	SCREW, HHC 3/8 - 16 X 1-3/4	1	
6	2064	ROD END, 3/8 -24 FEM RH	1	
7	2199	NUT, HEX JAM 3/8 -24	1	
8	10136	WASHER, FLAT 3/8 SAE	AR	
9	10133	NUT, JAM 3/8 - 16	1	
10	29448	SCREW, THP 1/4 - 20 X X 1.25	4	
11	25365	RAISE-LOWER W/A	1	
12	15414	UNDERCARRIAGE ASSEMBLY	1	
13	25489	PLUG, 3/4 BLK PLASTIC	2	
14	25409	CAP, 1-1/2 ID BLACK	1	

FCG1 CONCRETE SAW — HANDLE & DEPTH ADJUSTER ASSY.

HANDLE & DEPTH ADJUSTER ASSY.

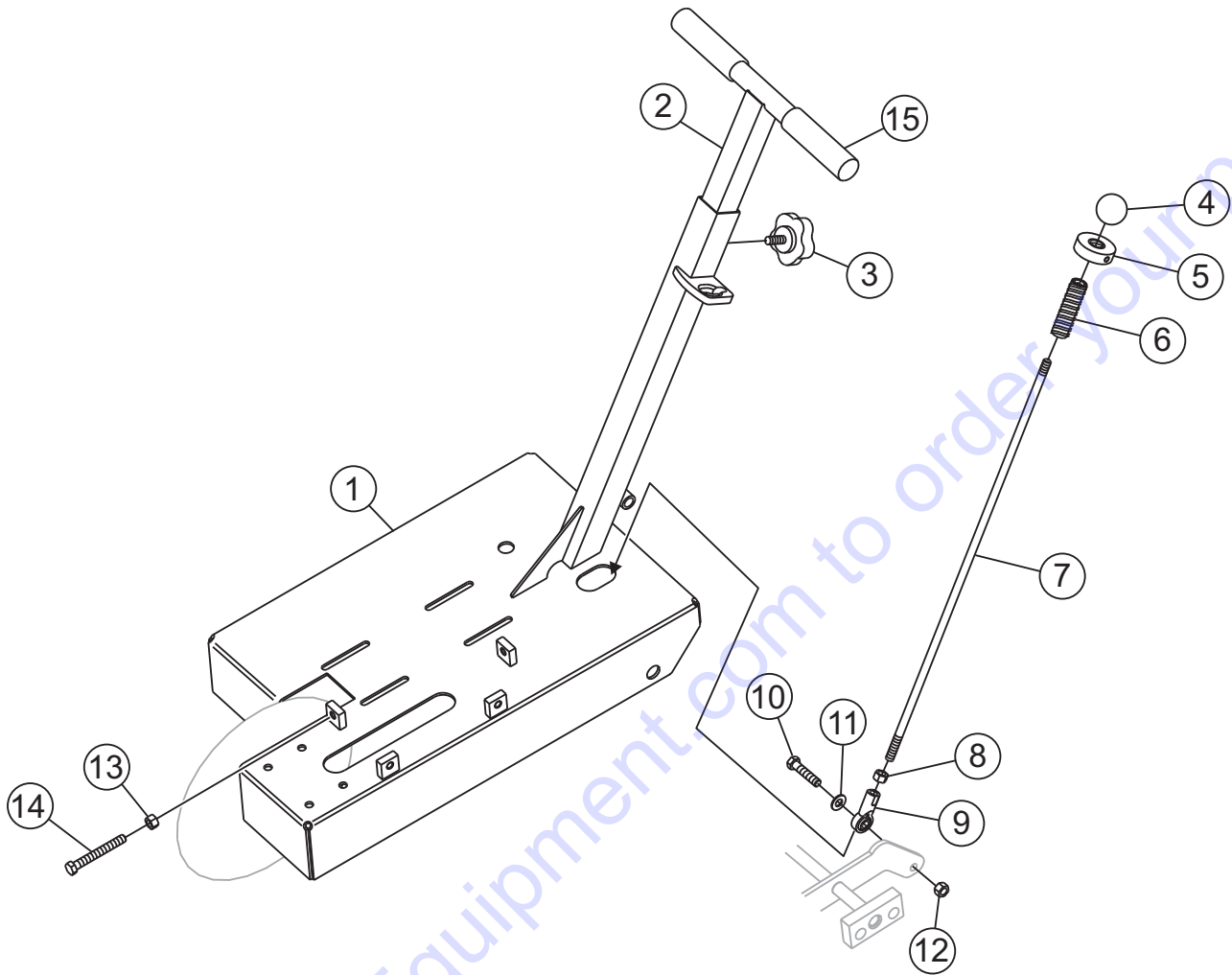

FCG1 CONCRETE SAW — HANDLE & DEPTH ADJUSTER ASSY.

HANDLE & DEPTH ADJUSTER ASSY.

<u>NO.</u>	<u>PART NO.</u>	<u>PART NAME</u>	<u>QTY.</u>	<u>REMARKS</u>
1	25357	FRAME	1	
2	25419	HANDLEBAR	1	
3	15503	KNOB, COMFORT GRIP	1	
4	4403	KNOB, SHIFT	1	
5	25448	DEPTH ADJUST DISK	1	
6	25480	SCREW PLUNGER, 1/4 - 20 X 17/32	1	
7	25446	ROD, DEPTH STOP	1	
8	2199	NUT, HEX JAM 3/8 -24	1	
9	2064	ROD END, 3/8 -24 FEM RH	1	
10	9154	SCREW, HHC 3/8 - 16 X 1-3/4	1	
11	10136	WASHER, FLAT 3/8 SAE	AR	
12	10133	NUT, NYLOC 3/8 - 16	1	
13	1007	NUT, HEX JAM 3/8 - 16	1	
14	9154	SCREW, HHC 3/8 - 16 X 3	1	
15	15081	GRIP, HANDLE	2	

Go to Discount-Equipment.com to order your parts

FCG1 CONCRETE SAW — ENGINE & BLADE DRIVE ASSY.

ENGINE & BLADE DRIVE ASSY.

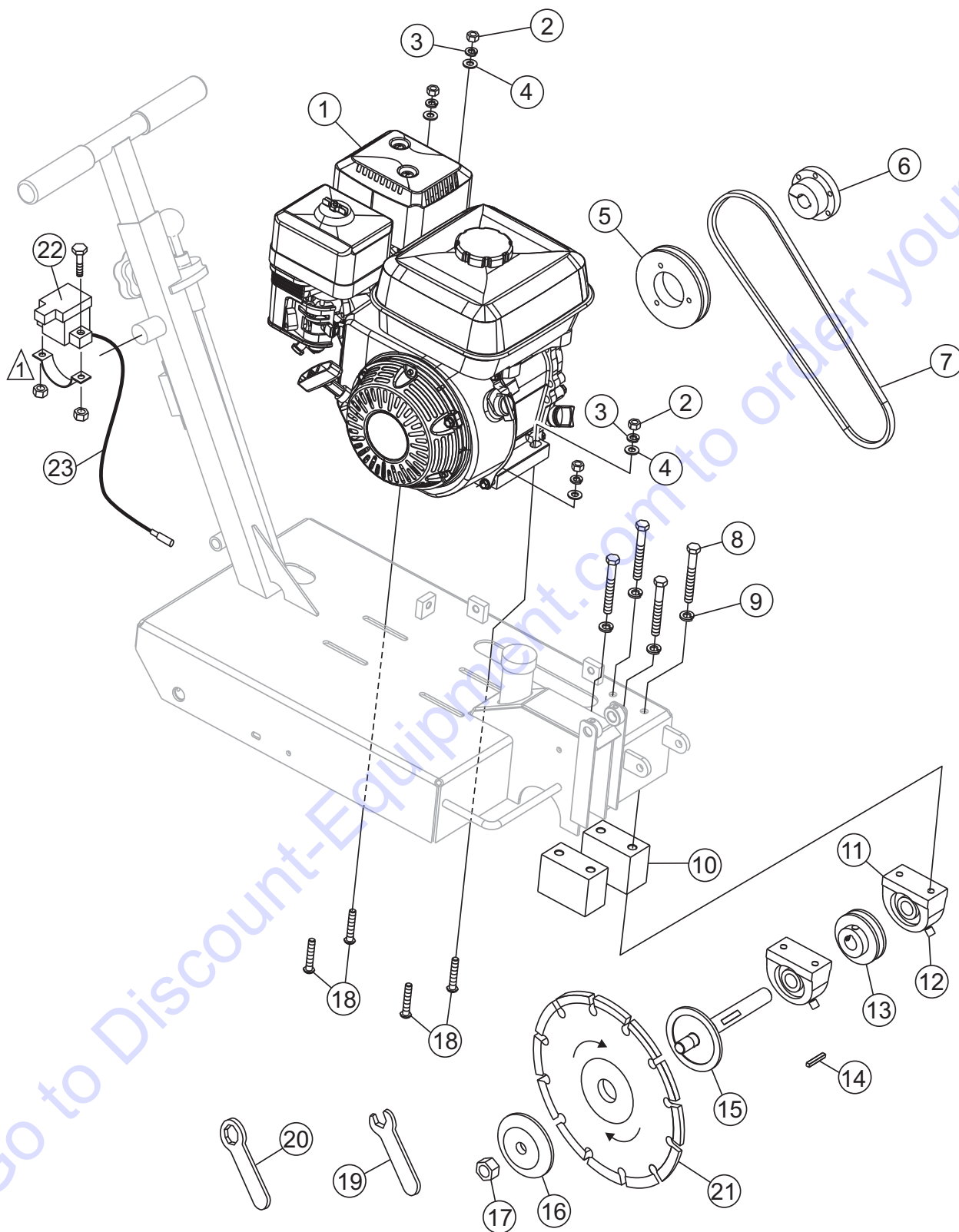

NOTES:

▲ SWITCH MOUNTING HARDWARE IS INCLUDED WITH SWITCH.

FCG1 CONCRETE SAW — ENGINE & BLADE DRIVE ASSY.

ENGINE & BLADE DRIVE ASSY.

NO.	PART NO.	PART NAME	QTY.	REMARKS
1	25378	ENGINE, 6.5 HP HONDA GX200QXC9 (SHOWN)	1	
2	25520	ENGINE, 7.0 HP ROBIN EX21	1	
2	0161 D	NUT, HEX FINISH 5/16 - 18	4	
3	0161 C	WASHER, LOCK 5/16 MED	4	
4	0300 B	WASHER, FLAT 5/16	4	
5	25356	PULLEY, 13V412SH	1	
6	25417	BUSHING, PULLEY SH - 3/4	1	
7	16052	BELT, 3VX335 GATES/OPTIPLEX	1	
8	0169	SCREW, HHC 3/8 - 16 X 3.0	4	
9	0166 A	WASHER, LOCK 3/8 MED	4	
10	25377	SPACER, BEARING	2	
11	15359	BEARING, PIL BLOCK, BRN. VTBS-212	2	
12	1162 A	CAP, GREASE ZERK #2	2	
13	25442	PULLEY, 1F3V26 3/4" BORE	1	
14	0627	KEY, SQ 3/16 X 1-1/4	1	
15	25380	BLADE, SHAFT/FLANGE ASM	1	
16	25418	FLANGE, 3.38 O.D.	1	
17	19710	NUT, HEX 5/8 - 11 LH THRD	1	
18	25410	BOLT, CARRAIGE 5/16 - 18 X 1.75	3	
19	25487	WRENCH, SERVICE 15/16 OPEN END	1	
20	25488	WRENCH, 5/8 COMBO	1	
21	9SWG	BLADE, DIAMOND BACK	1	ORDER FROM UNIT SALES DEPT.
22	35127	SWITCH, ENGINE SHUT-OFF MAGURA	1	SAFETY ITEM
23	35155	WIRE ASSY., ENGINE SHUT-OFF SWITCH	1	SAFETY ITEM

HONDA GX200QXC9 — AIR CLEANER (CYCLONE) ASSY.

AIR CLEANER (CYCLONE) ASSY.

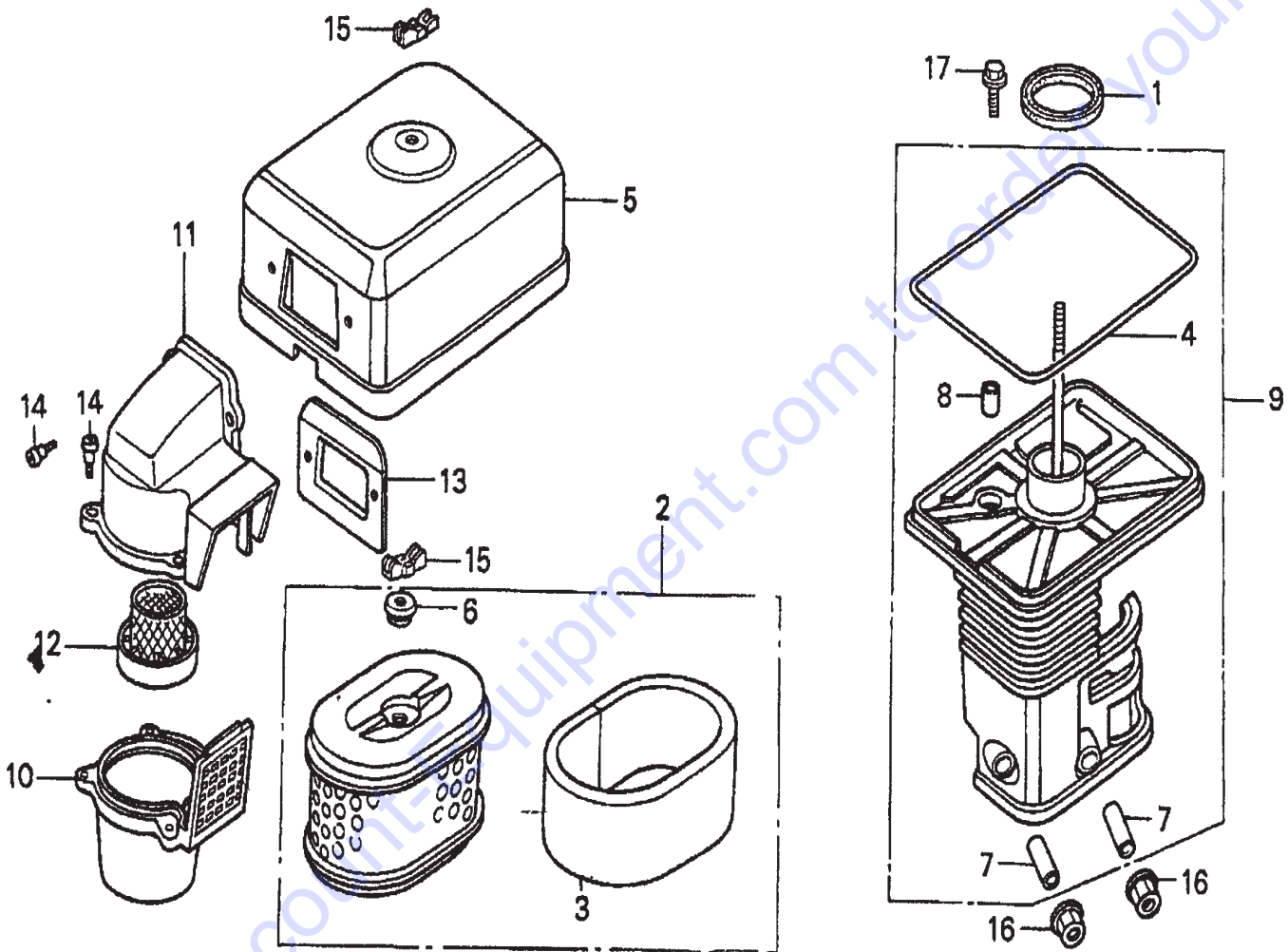

HONDA GX200QXC9 — AIR CLEANER (CYCLONE) ASSY.

AIR CLEANER (CYCLONE) ASSY.

<u>NO.</u>	<u>PART NO.</u>	<u>PART NAME</u>	<u>QTY.</u>	<u>REMARKS</u>
1	16271ZE1000	GASKET, ELBOW	1	
2	17210ZE1505	ELEMENT, AIR CLEANER (DUAL)	1	INCLUDES ITEMS W/*
3*	17218ZE1821	FILTER (OUTER)	1	
4*	17219733010	GASKET, AIR CLEANER COVER	1	
5	17230ZE1841	COVER, AIR CLEANER (DUAL)	1	
6*	17232891000	GROMMET, AIR CLEANER	1	
7+	17238ZE7010	COLLAR, AIR CLEANER	2	
8+	17239733000	COLLAR B, AIR CLEANER	1	
9	17410ZE1840	ELBOW, AIR CLEANER	1	INCLUDES ITEMS W/+
10	17470ZE1841	CASE, PRE AIR CLEANER	1	
11	17475ZE1841	CAP, PREAIR CLEANER	1	
12	17476ZE1841	GUIDE, PRE AIR CLEANER	1	
13	17478ZE1841	PLATE, PRE AIR CLEANER	1	
14	90300GB0900	BOLT, MUDGUARD	5	
15	90325044000	WINGNUT, TOOL BOX SETTING	2	
16	9405006000	NUT, FLANGE 6MM	2	
17	957010602000	BOLT, FLANGE 6 X 20	1	

Go to Discount-Equipment.com to order your parts

HONDA GX200QXC9 — CAMSHAFT ASSY.

CAMSHAFT ASSY.

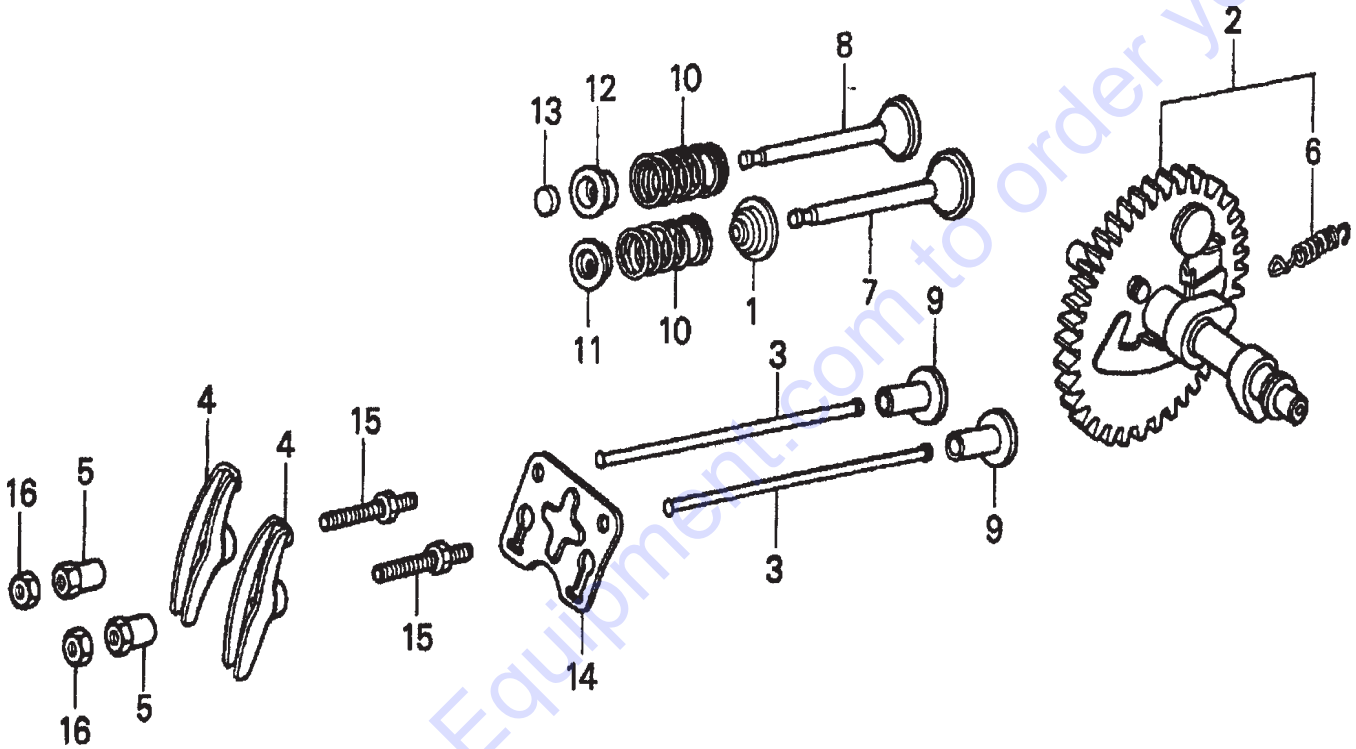

HONDA GX200QXC9 — CAMSHAFT ASSY.

CAMSHAFT ASSY.

<u>NO.</u>	<u>PART NO.</u>	<u>PART NAME</u>	<u>QTY.</u>	<u>REMARKS</u>
1	12209ZH8003	SEAL, VALVE STEM	1	
2	14100ZL0000	CAMSHAFT ASSEMBLY	1	INCLUDES ITEM W/*
3	14410ZE1010	ROD, PUSH	2	
4	14431ZE1000	ARM, VALVE ROCKER	2	
5	14451ZE1013	PIVOT, ROCKER ARM	2	
6*	14568ZE1000	SPRING, WEIGHT RETURN	1	
7	14711ZF1000	VALVE, INTAKE	1	
8	14721ZF1000	VALVE, EXHAUST	1	
9	14731ZL0000	LIFTER, VALVE	2	
10	14751ZF1000	SPRING, VALVE	2	
11	14771ZE1000	RETAINER, INTAKE VALVE SPRING	1	
12	14773ZE1000	RETAINER, EXHAUST VALVE SPRING	1	
13	14781ZE1000	ROTATOR, VALVE	1	
14	14791ZE1010	PLATE, PUSH ROD GUIDE	1	
15	90012ZE0010	BOLT, PIVOT 8MM	2	
16	90206ZE1000	NUT, PIVOT ADJ.	2	

Go to Discount-Equipment.com to order your parts

HONDA GX200QXC9 — CARBURETOR ASSY.

CARBURETOR ASSY.

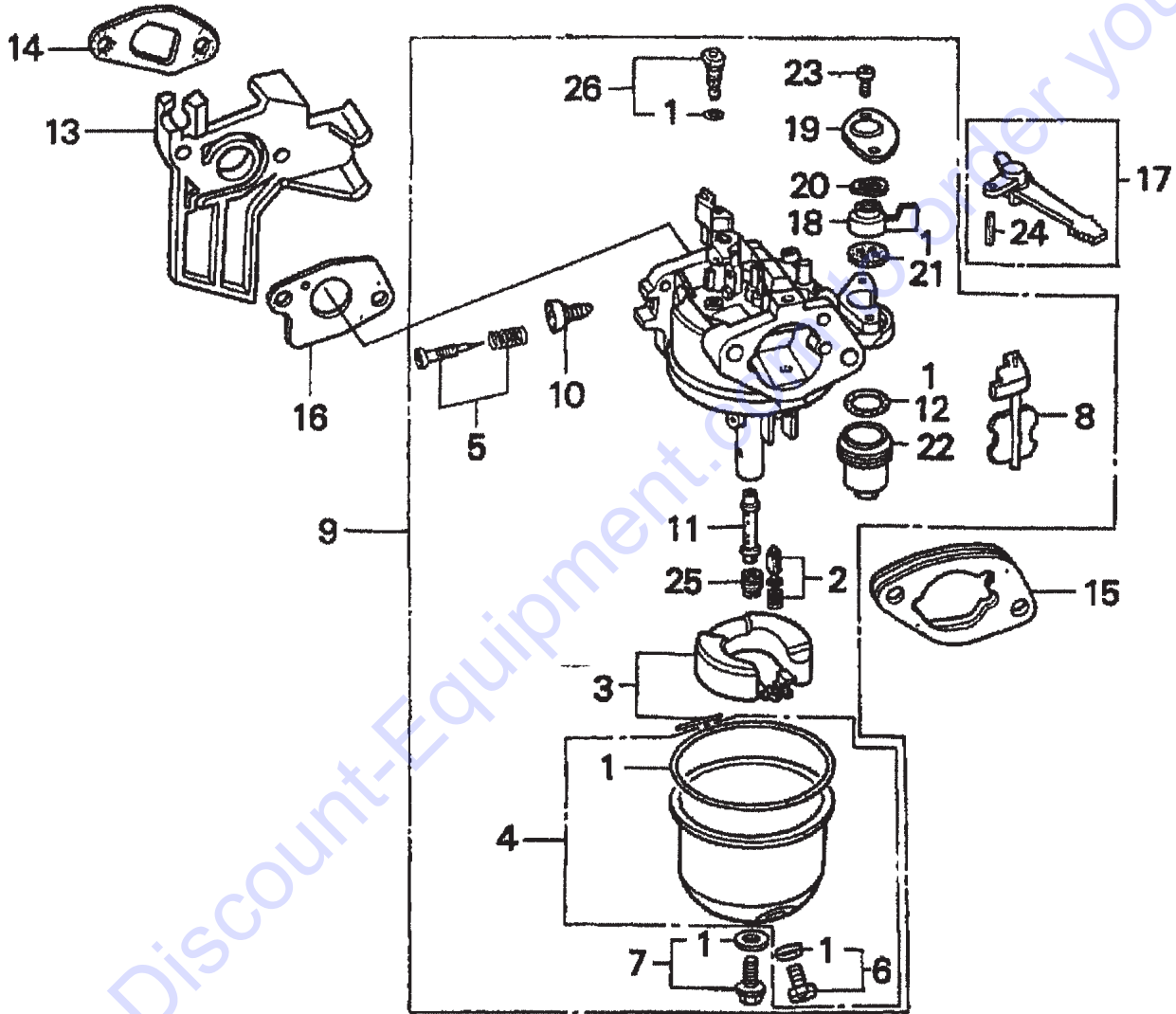

HONDA GX200QXC9 — CARBURETOR ASSY.

CARBURETOR ASSY.

<u>NO.</u>	<u>PART NO.</u>	<u>PART NAME</u>	<u>QTY.</u>	<u>REMARKS</u>
1*	16010ZE1812	GASKET SET	1	
2*	16011ZE0005	VALVE SET, FLOAT	1	
3*	16013ZE0005	FLOAT SET	1	
4*	16015ZE0831	CHAMBER SET, FLOAT	1	
5*	16016ZH7W01	SCREW SET	1	
6*	16024ZE1811	SCREW SET, DRAIN	1	
7*	16028ZE0005	SCREW SET B	1	
8*	16044ZE0005	CHOKE SET	1	
9	16100ZL0V21	CARBURETOR ASSEMBLY (BE64F B)	1	INCLUDES ITEMS W/*
10*	16124ZE0005	SCREW, THROTTLE STOP	1	
11*	16166ZL0V20	NOZZLE, MAIN	1	
12*	16173001004	GASKET, FUEL STRAINER CUP	1	
13	16211ZL0000	INSULATOR, CARBURETOR	1	
14	16212ZH8800	GASKET, INSULATOR	1	
15	16220ZE1020	SPACER, CARBURETOR	1	
16	16221ZH8801	GASKET, CARBURETOR	1	
17	16610ZE1000	LEVER, CHOKE (STANDARD)	1	INCLUDES ITEM W/ %
18*	16953ZE1812	LEVER, VALVE	1	
19*	16954ZE1812	PLATE, LEVER SETTING	1	
20*	16956ZE1811	SPRING, VALVE LEVER	1	
21*	16957ZE1812	GASKET, VALVE	1	
22*	16967ZE0811	CUP, FUEL STRAINER	1	
23*	93500030060H	SCREW, PAN 3 X 6	2	
24 %	9430520122	PIN, SPRING 2 X12	1	
25	99101ZH80700	JET, MAIN #70 (OPTIONAL)	1	
25*	99101ZH80720	JET, MAIN #72	1	
25*	99101ZH80750	JET, MAIN #75	1	
26*	99204ZA00450	JET SET, PILOT #45	1	

HONDA GX200QXC9 — CONTROL ASSY.

CONTROL ASSY.

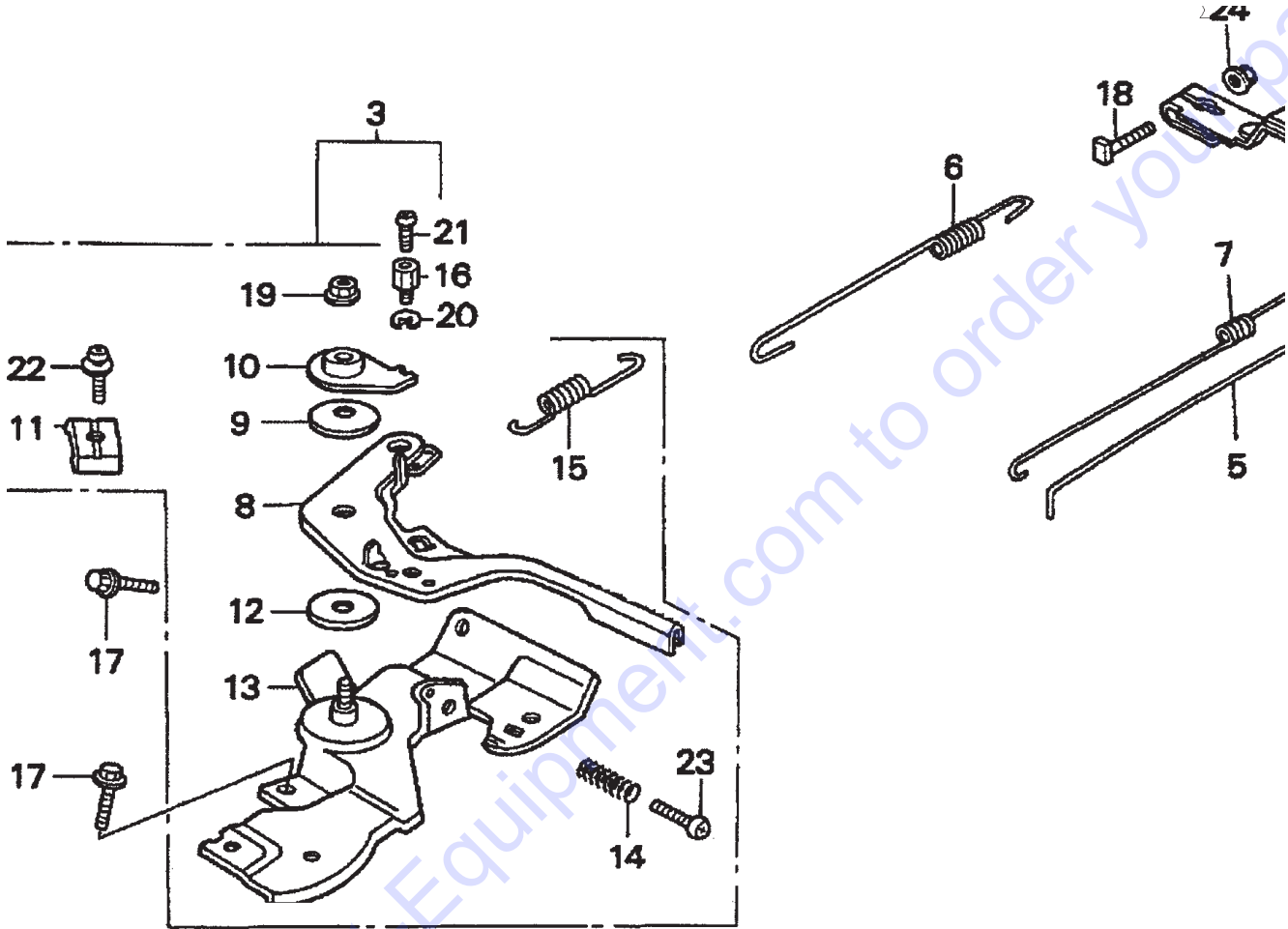

HONDA GX200QXC9 — CONTROL ASSY.

CONTROL ASSY.

<u>NO.</u>	<u>PART NO.</u>	<u>PART NAME</u>	<u>QTY.</u>	<u>REMARKS</u>
3	16500ZH8853	CONTROL ASSEMBLY (CYCLONE)	1	INCLUDES ITEMS W/*
4	16551ZL0000	ARM, GOVERNOR	1	
5	16555ZE1000	ROD, GOVERNOR	1	
6	16561ZL0000	SPRING, GOVERNOR	1	
7	16562ZE1020	SPRING, THROTTLE RETURN	1	
8*	16571ZH8020	LEVER, CONTROL	1	
9*	16574ZE1000	SPRING, LEVER	1	
10*	16575ZH8000	WASHER, CONTROL LEVER	1	
11*	16576891000	HOLDER, CABLE	1	
12*	16578ZE1000	SPACER, CONTROL LEVER	1	
13*	16580ZH8853	BASE, CONTROL (CYCLONE)	1	
14*	16584883300	SPRING, CONTROL ADJUSTING	1	
15*	16592ZE1810	SPRING, CABLE RETURN	1	
16*	16594883010	HOLDER, WIRE	1	
17	90013883000	BOLT, FLANGE 6 X12 (CT200)	2	
18	90015ZE5010	BOLT, GOVERNOR ARM	1	
19*	90114SA0000	NUT, SELF- LOCK 6MM	1	
20*	90605230000	CIRCLIP 5MM	1	
21*	93500040060H	SCREW, PAN 4 X6	1	
22*	93500050160A	SCREW, PAN 5 X16	1	
23*	93500050250H	SCREW, PAN 5 X25	1	
24	9405006000	NUT, FLANGE 6MM	1	

Go to Discount-Equipment.com to order your parts

HONDA GX200QXC9 — CRANKCASE COVER ASSY.

CRANKCASE COVER ASSY.

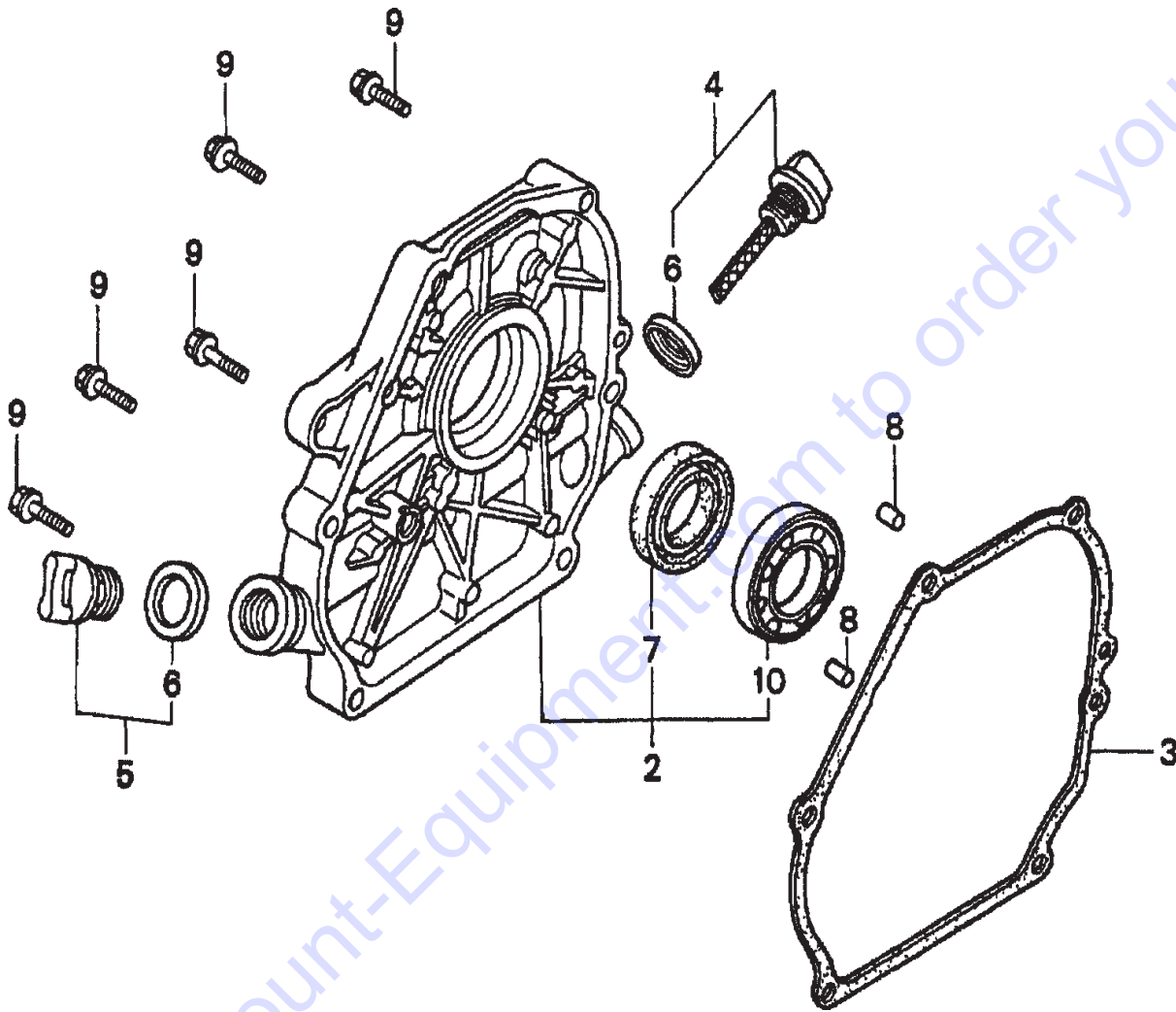

HONDA GX200QXC9 — CRANKCASE COVER ASSY.

CRANKCASE COVER ASSY.

<u>NO.</u>	<u>PART NO.</u>	<u>PART NAME</u>	<u>QTY.</u>	<u>REMARKS</u>
2	11300ZE1641	COVER ASSEMBLY, CRANKCASE (U- TYPE)	1	INCLUDES ITEMS W/*
3	11381ZH8801	GASKET, CASE COVER (NON- ASBESTOS)	1	USE UP TO ENGINE SN 1002566
3	11381ZL0000	GASKET, CASE COVER	1	USE FROM ENGINE SN 1002567
4	15600ZE1003	CAP ASSEMBLY, OIL FILLER	1	INCLUDES ITEM W/+
5	15600ZG4003	CAP ASSEMBLY, OIL FILLER	1	INCLUDES ITEM W/+
6+	15625ZE1003	GASKET, OIL FILLER CAP	2	
7*	91202883005	OIL SEAL 25 X41 X6	1	
8	9430108140	PIN A, DOWEL 8 X14	2	
9	957010803200	BOLT, FLANGE 8 X32	6	
10*	961006205000	BEARING, RADIAL BALL 6205	1	

Go to Discount-Equipment.com to order your parts

HONDA GX200QXC9 — CRANKSHAFT ASSY.

CRANKSHAFT ASSY.

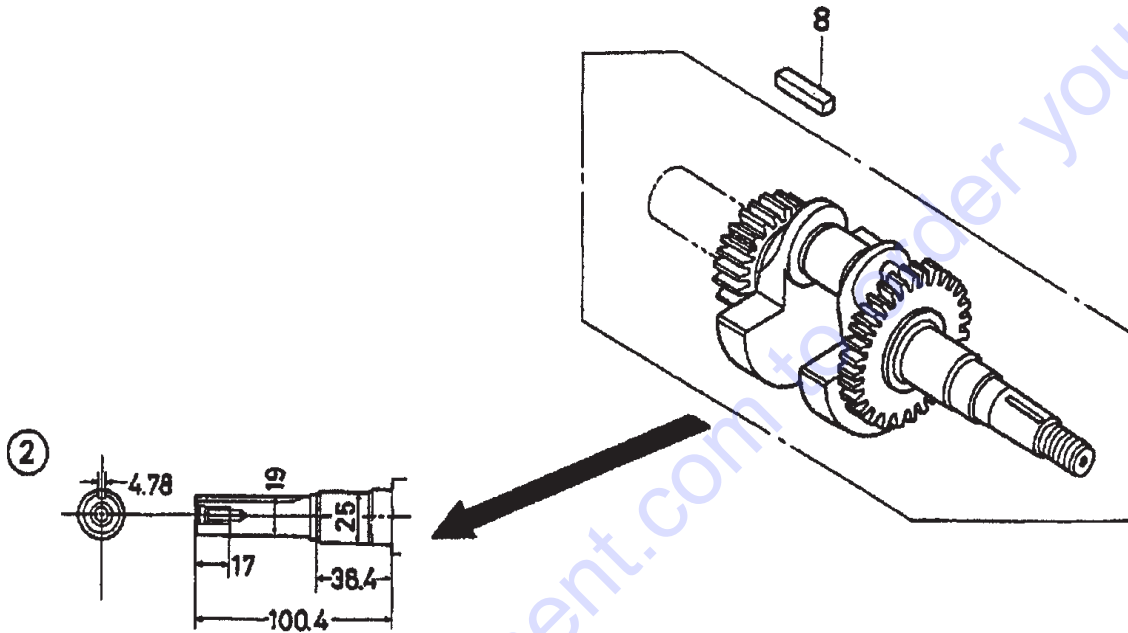

HONDA GX200QXC9 — CRANKSHAFT ASSY.

CRANKSHAFT ASSY.

<u>NO.</u>	<u>PART NO.</u>	<u>PART NAME</u>	<u>QTY.</u>	<u>REMARKS</u>
2	13310ZL0600	CRANKSHAFT (Q-TYPE)	1	
8	90745ZE1600	KEY 4.78 X4.78 X38	1	

Go to Discount-Equipment.com to order your parts

HONDA GX200QXC9 — CYLINDER BARREL ASSY.

CYLINDER BARREL ASSY.

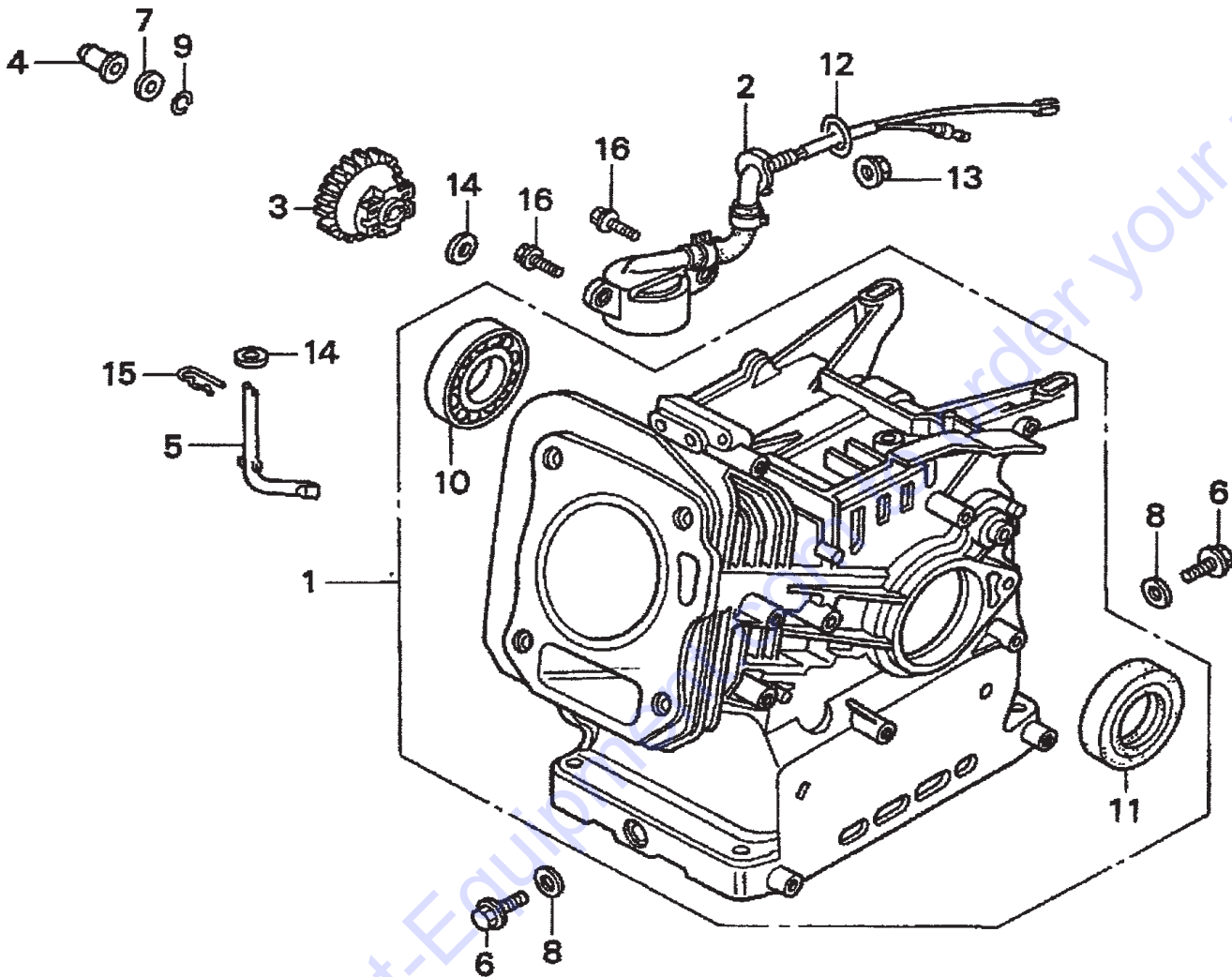

HONDA GX200QXC9 — CYLINDER BARREL ASSY.

CYLINDER BARREL ASSY.

<u>NO.</u>	<u>PART NO.</u>	<u>PART NAME</u>	<u>QTY.</u>	<u>REMARKS</u>
1	12000ZL0810	CYLINDER ASSEMBLY (OIL ALERT)	1	INCLUDES ITEMS W/*
2	15510ZE1033	SWITCH ASSEMBLY, OIL LEVEL	1	
3	16506ZL0000	GOVERNOR ASSEMBLY	1	
4	16531ZE1000	SLIDER, GOVERNOR	1	
5	16541ZE1000	SHAFT, GOVERNOR ARM	1	
6	90131ZE1000	BOLT, DRAIN PLUG	2	
7	90451ZE1000	WASHER, THRUST 6MM	1	
8	90601ZE1000	WASHER, DRAIN PLUG 10.2MM	2	
9	90602ZE1000	CLIP, GOVERNOR HOLDER	1	
10*	91001ZF1003	BEARING, RADIAL BALL 6205	1	
11*	91202883005	OIL SEAL 25 X41 X6	1	
12	91353671003	O- RING 13.5 X1.5 (ARAI)	1	
13	9405010000	NUT, FLANGE 10MM	1	
14	9410106800	WASHER, PLAIN 6MM	2	
15	9425108000	PIN, LOCK 8MM	1	
16	957010601200	BOLT, FLANGE 6 X12	2	

Go to Discount-Equipment.com to order your parts

HONDA GX200QXC9 — CYLINDER HEAD ASSY.

CYLINDER HEAD ASSY.

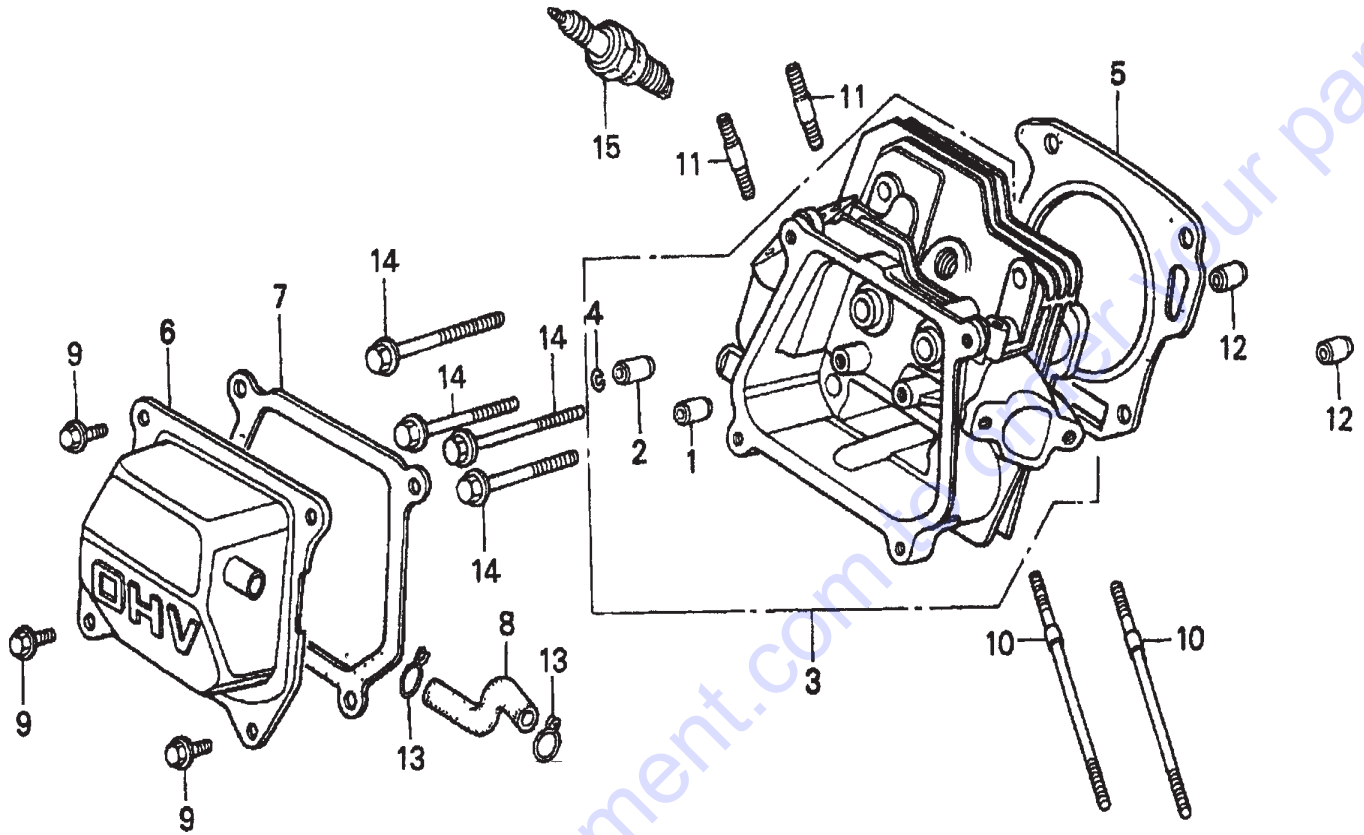

HONDA GX200QXC9 — CYLINDER HEAD ASSY.

CYLINDER HEAD ASSY.

<u>NO.</u>	<u>PART NO.</u>	<u>PART NAME</u>	<u>QTY.</u>	<u>REMARKS</u>
1*	12204ZE1306	GUIDE, VALVE OS (OPTIONAL)	1	
2*	12205ZE1315	GUIDE, EXHAUST VALVE OS (OPTIONAL)	1	
3	12210ZL0000	CYLINDER HEAD	1	INCLUDES ITEMS W/*
4*	12216ZE5300	CLIP, VALVE GUIDE	1	
5	12251ZL0003	GASKET, CYLINDER HEAD	1	
6	12310ZE1841	COVER, HEAD (BREATHER TUBE)	1	
7	12391ZE1000	GASKET, CYLINDER HEAD COVER	1	
8	15721ZE1840	TUBE, BREATHER	1	
9	90013883000	BOLT, FLANGE 6 X12 (CT200)	4	
10	90043ZE1020	BOLT, STUD 6 X109	2	
11	90047ZE1000	BOLT, STUD 8 X32	2	
12	9430110160	PIN A DOWEL 10 X16	2	
13	9500280000	CLIP, TUBE C12	2	
14	957230806000	BOLT, FLANGE 8 X60	4	
15	9807956846	SPARK PLUG BPR6ES (NGK)	1	
15	9807956855	SPARK PLUG W20EPR- U (DENSO)	1	

Go to Discount-Equipment.com to order your parts

HONDA GX200QXC9 — FAN COVER ASSY.

FAN COVER ASSY.

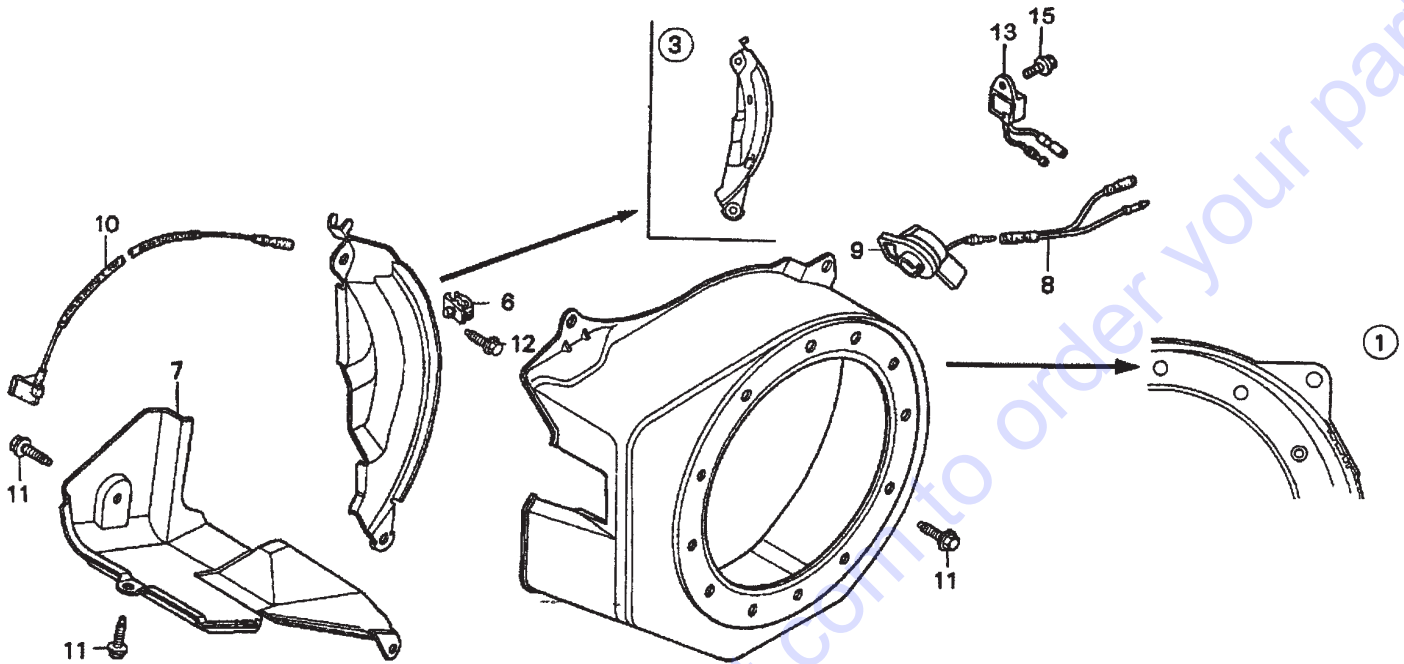

HONDA GX200QXC9 — FAN COVER ASSY.

FAN COVER ASSY.

<u>NO.</u>	<u>PART NO.</u>	<u>PART NAME</u>	<u>QTY.</u>	<u>REMARKS</u>
1	19610ZL0000ZB	COVER, FAN *R8* BRIGHT RED	1	
3	19611ZH8810	PLATE, SIDE (OIL ALERT)	1	
6	19613ZE1010	CLAMP, CORD	1	
7	19630ZH8000	SHROUD	1	
8	32197ZH8003	SUB- HARNESS	1	
9	36100ZH7003	SWITCH ASSEMBLY, ENGINE STOP	1	
10	36101ZE1010	WIRE, STOP SWITCH 370MM	1	
11	90013883000	BOLT, FLANGE 6 X12 (CT200)	6	
12	90022888010	BOLT, FLANGE 6 X20 (CT200)	1	
13	34150ZH7003	ALERT UNIT, OIL	1	
15	957010600800	BOLT, FLANGE 6 X8	1	

Go to Discount-Equipment.com to order your parts

HONDA GX200QXC9 — FLYWHEEL ASSY.

FLYWHEEL ASSY.

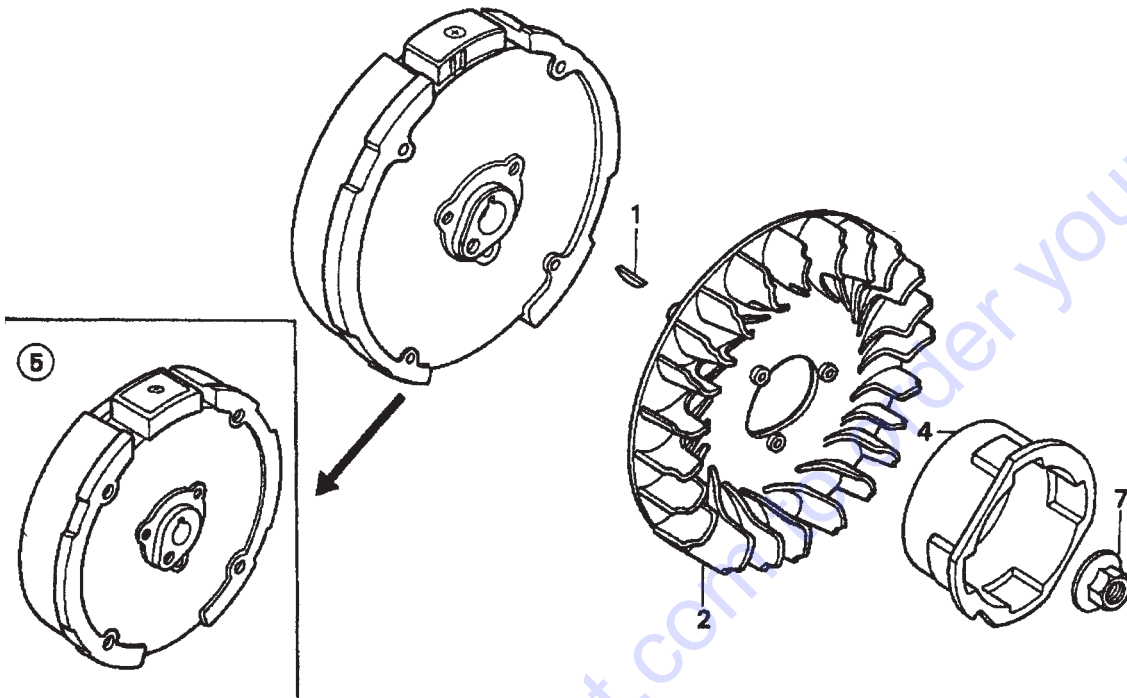

HONDA GX200QXC9 — FLYWHEEL ASSY.

FLYWHEEL ASSY.

<u>NO.</u>	<u>PART NO.</u>	<u>PART NAME</u>	<u>QTY.</u>	<u>REMARKS</u>
1	13331357000	KEY, SPECIAL WOODRUFF 25 X18	1	
2	19511ZE1000	FAN, COOLING	1	
4	28451ZL0000	PULLEY, STARTER	1	
5	31100ZE7010	FLYWHEEL, STANDARD	1	
7	90201878003	NUT, SPECIAL 14MM	1	

Go to Discount-Equipment.com to order your parts

HONDA GX200QXC9 — FUEL TANK ASSY.

FUEL TANK ASSY.

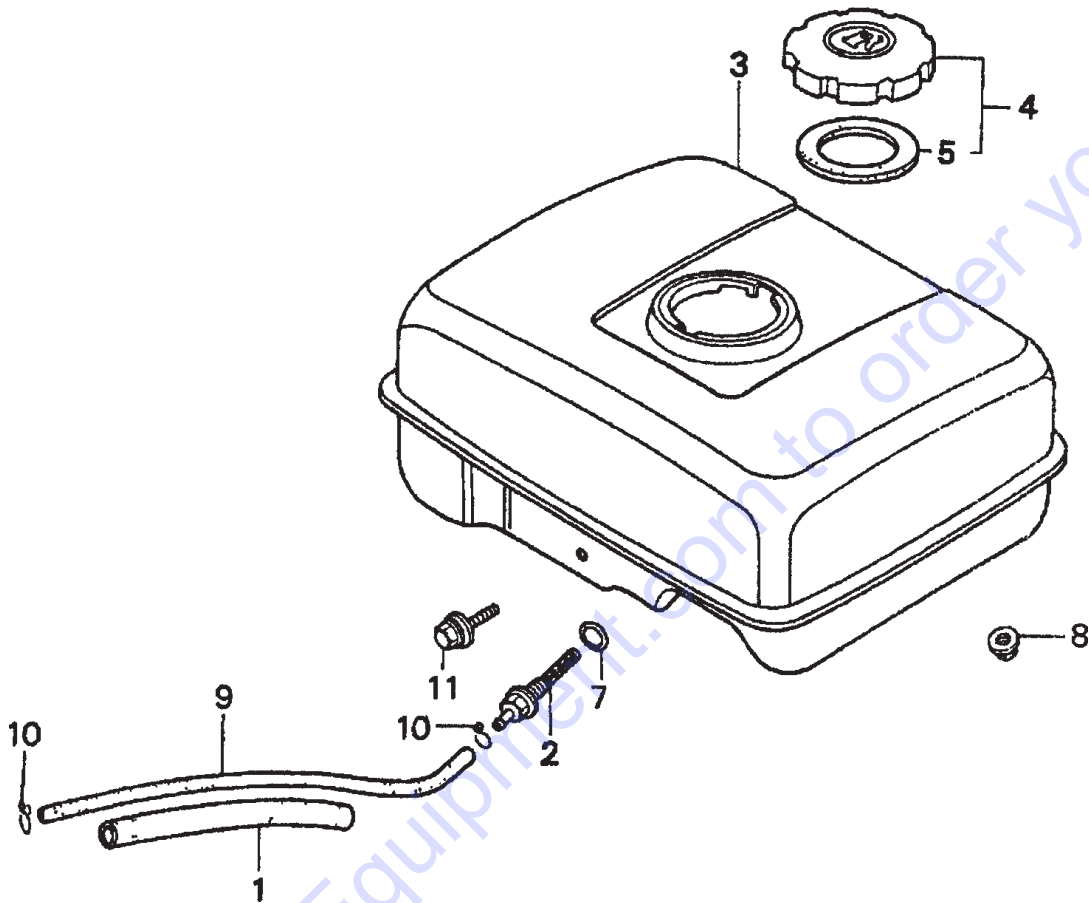

HONDA GX200QXC9 — FUEL TANK ASSY.

FUEL TANK ASSY.

<u>NO.</u>	<u>PART NO.</u>	<u>PART NAME</u>	<u>QTY.</u>	<u>REMARKS</u>
1	16854ZH8000	RUBBER, SUPPORTER 107MM	1	
2	16955ZE1000	JOINT, FUEL TANK	1	
3	17510ZE1020ZA	TANK, FUEL *NH31* MCKINLEY WHITE	1	
4	17620ZH7023	CAP, FUEL FILLER	1	INCLUDES ITEM W/*
5*	17631ZH7003	GASKET, FUEL FILLER CAP	1	
7	91353671003	O- RING 13.5 X1.5 (ARAI)	1	
8	9405006000	NUT, FLANGE 6MM	2	
9	950014500360M	BULK HOSE, FUEL (4.5 X3000) (4.5 X140)	1	
10	9500202080	CLIP, TUBE B8	2	
11	957010603000	BOLT, FLANGE 6 X30	1	

Go to Discount-Equipment.com to order your parts

HONDA GX200QXC9 — IGNITION COIL ASSY.

IGNITION COIL ASSY.

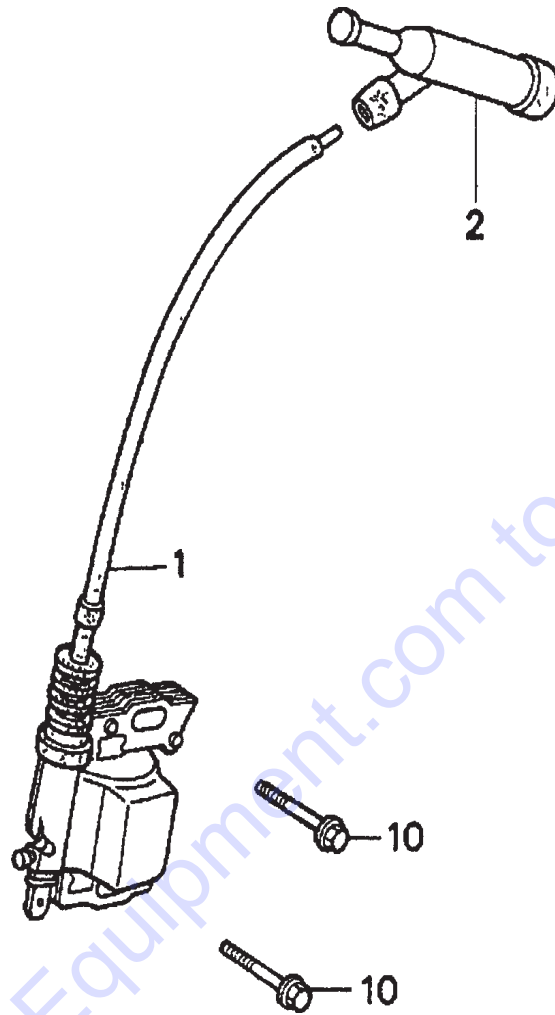

HONDA GX200QXC9 — IGNITION COIL ASSY.

IGNITION COIL ASSY.

<u>NO.</u>	<u>PART NO.</u>	<u>PART NAME</u>	<u>QTY.</u>	<u>REMARKS</u>
1	30500ZE1033	COIL ASSEMBLY, IGNITION	1	
2	30700ZE1013	CAP ASSEMBLY, NOISE SUPPRESSOR	1	
10	90121952000	BOLT, FLANGE 6 X25	2	

Go to Discount-Equipment.com to order your parts

HONDA GX200QXC9 — MUFFLER ASSY.

MUFFLER ASSY.

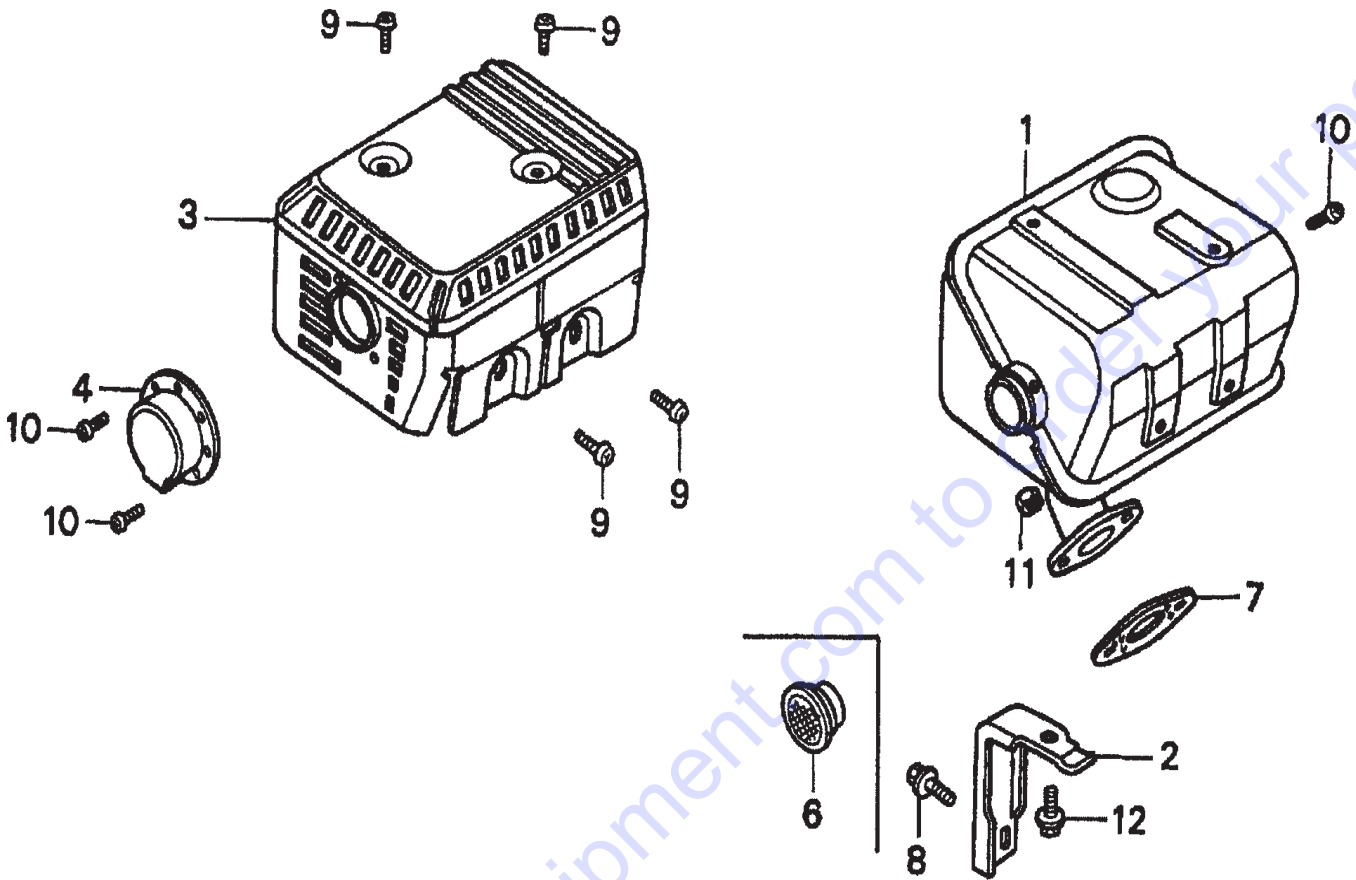

HONDA GX200QXC9 — MUFFLER ASSY.

MUFFLER ASSY.

<u>NO.</u>	<u>PART NO.</u>	<u>PART NAME</u>	<u>QTY.</u>	<u>REMARKS</u>
1	18310ZL0000	MUFFLER	1	
2	18315ZE1000	STAY, MUFFLER	1	
3	18320ZF1H51	PROTECTOR, MUFFLER	1	
4	18331883810	CAP, MUFFLER	1	
6	18361ZL0000	NETTING, WIRE FLANGE	1	
7	18381ZH8800	GASKET, MUFFLER	1	
8	90016ZE1000	BOLT, FLANGE 6 X13	1	
9	90050ZE1000	SCREW, TAPPING 5 X8	4	
10	90055ZE1000	SCREW, TAPPING 4 X6	3	
11	94001080000S	NUT, HEX. 8MM	2	
12	957010601200	BOLT, FLANGE 6 X12	1	

Go to Discount-Equipment.com to order your parts

HONDA GX200QXC9 — PISTON ASSY.

PISTON ASSY.

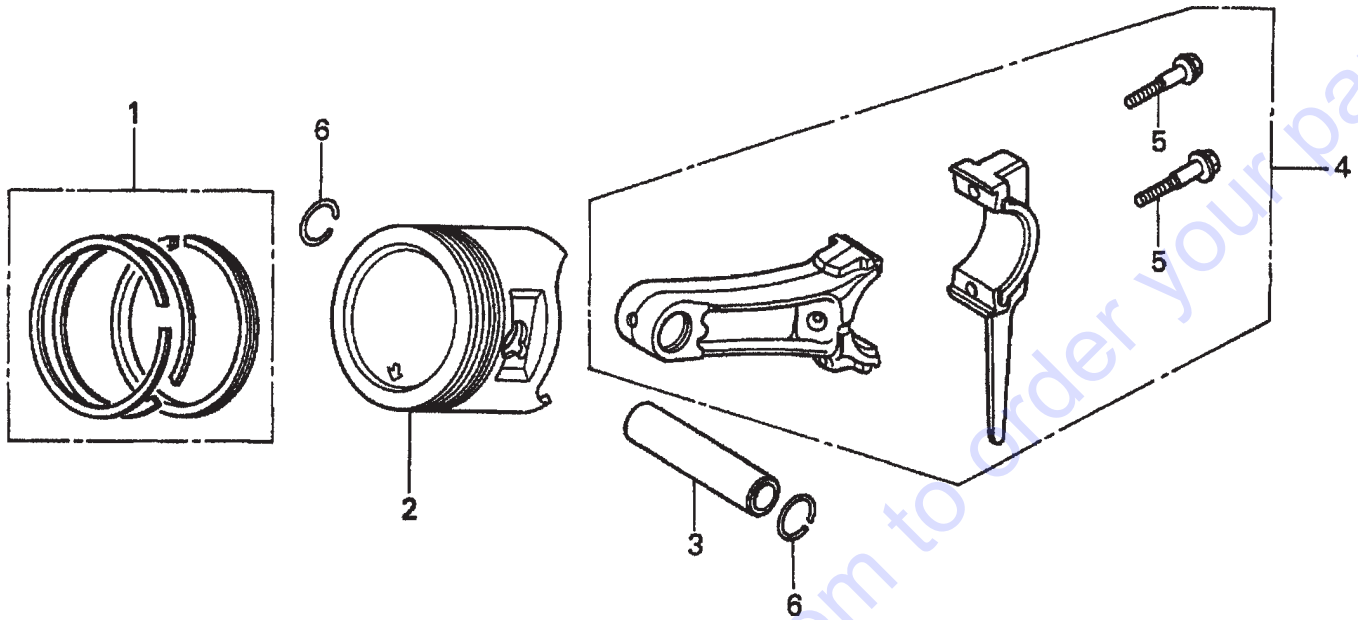

HONDA GX200QXC9 — PISTON ASSY.

PISTON ASSY.

<u>NO.</u>	<u>PART NO.</u>	<u>PART NAME</u>	<u>QTY.</u>	<u>REMARKS</u>
1	13010ZL0003	RING SET, PISTON (STANDARD)	1	
1	13011ZL0003	RING SET, PISTON (OS 0.25)	1	
1	13012ZL0003	RING SET, PISTON (OS 0.50)	1	
1	13013ZL0003	RING SET, PISTON (0.75)	1	
2	13101ZL0000	PISTON (STANDARD)	1	
2	13102ZL0000	PISTON (OS 0.25)	1	
2	13103ZL0000	PISTON (OS 0.50)	1	
2	13104ZL0000	PISTON (0.75)	1	
3	13111ZE1000	PIN, PISTON	1	
4	132A0ZE1000	ROD ASSEMBLY, CONNECTING (US 0.25)	1	
4	13200ZE1010	ROD ASSEMBLY, CONNECTING	1	
5	90001ZE1000	BOLT, CONNECTING ROD	2	
6	90551ZE1000	CLIP, PISTON PIN 18MM	2	

HONDA GX200QXC9 — RECOIL STARTER ASSY.

RECOIL STARTER ASSY.

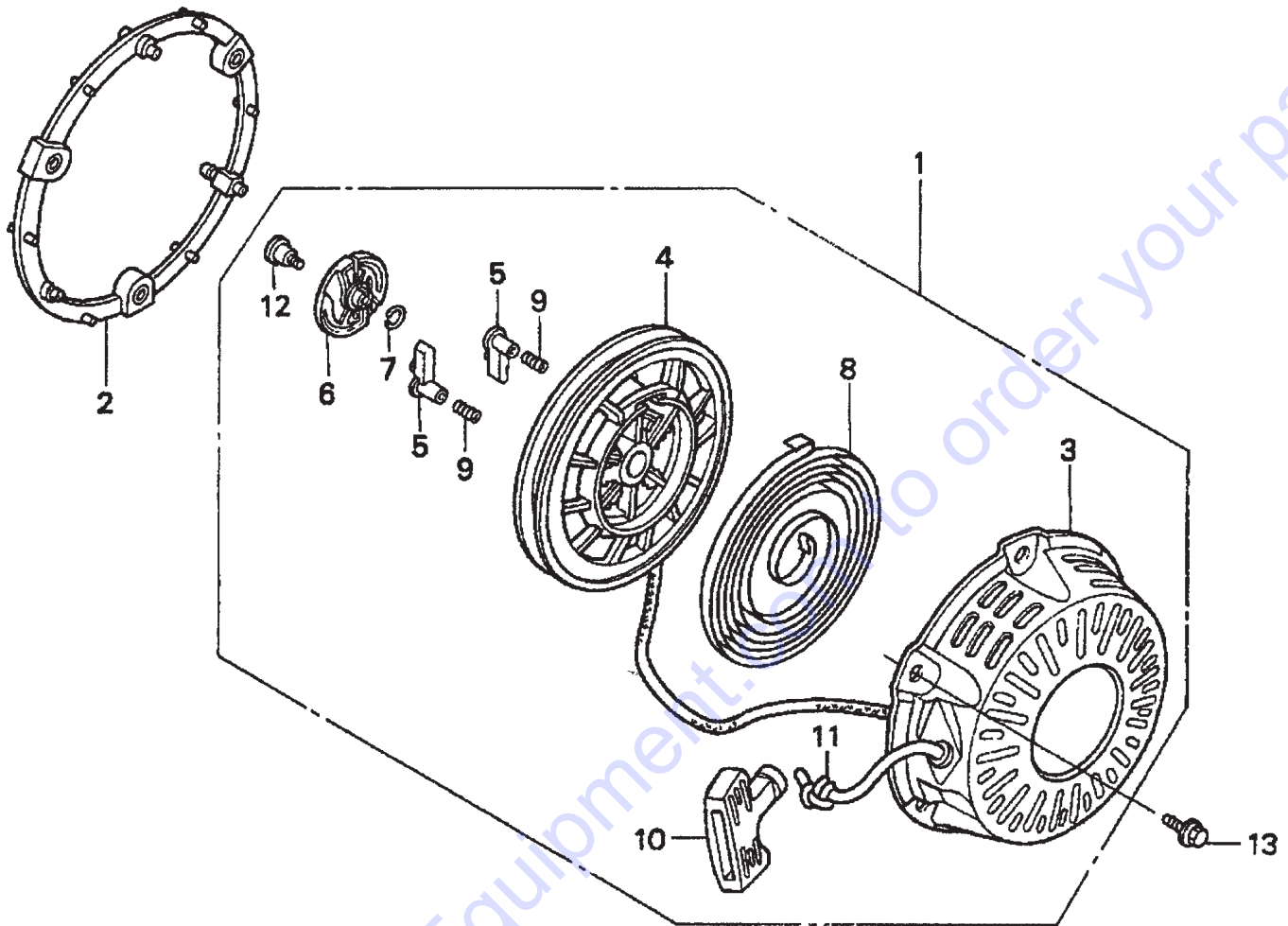

HONDA GX200QXC9 — RECOIL STARTER ASSY.

RECOIL STARTER ASSY.

<u>NO.</u>	<u>PART NO.</u>	<u>PART NAME</u>	<u>QTY.</u>	<u>REMARKS</u>
1	28400ZH8013ZA	STARTER ASSY., RECOIL *R8* BRIGHT RED	1	INCLUDES ITEMS W/*
2	28405ZL0000ZB	SPACER, RECOIL STARTER MOUNTING *R8* BRIGHT RED	1	
3*	28410ZH8003ZA	CASE, RECOIL STARTER *R8* BRIGHT RED	1	
4*	28420ZH8013	REEL, RECOIL STARTER	1	
5*	28422ZH8013	RATCHET, STARTER	2	
6*	28433ZH8003	GUIDE, RATCHET	1	
7*	28441ZH8003	SPRING, FRICTION	1	
8*	28442ZH8003	SPRING, RECOIL STARTER	1	
9*	28443ZH8003	SPRING, RETURN	2	
10*	28461ZH8003	KNOB, RECOIL STARTER	1	
11*	28462ZH8003	ROPE, RECOIL STARTER	1	
12*	90003ZH8003	SCREW, SETTING	1	
13	957000601800	BOLT, FLANGE 6 X18	3	

Go to Discount-Equipment.com to order your parts

HONDA GX200QXC9 — GASKET KIT ASSY.

GASKET KIT ASSY.

<u>NO.</u>	<u>PART NO.</u>	<u>PART NAME</u>	<u>QTY.</u>	<u>REMARKS</u>
	06111ZL0000	GASKET KIT	1	INCLUDES ITEMS W/*
1*	11381ZL0000	GASKET, CASE COVER	1	
2*	12251ZL0003	GASKET, CYLINDER HEAD	1	
3*	12391ZE1000	GASKET, CYLINDER HEAD COVER	1	
4*	15625ZE1003	GASKET, OIL FILLER CAP	1	
5*	16212ZH8800	GASKET, INSULATOR	1	
6*	16221ZH8800	GASKET, CARBURETOR	1	
7*	18381ZH8800	GASKET, MUFFLER	1	

Go to Discount-Equipment.com to order your parts

HONDA GX200QXC9 — LABELS ASSY.

LABELS ASSY.

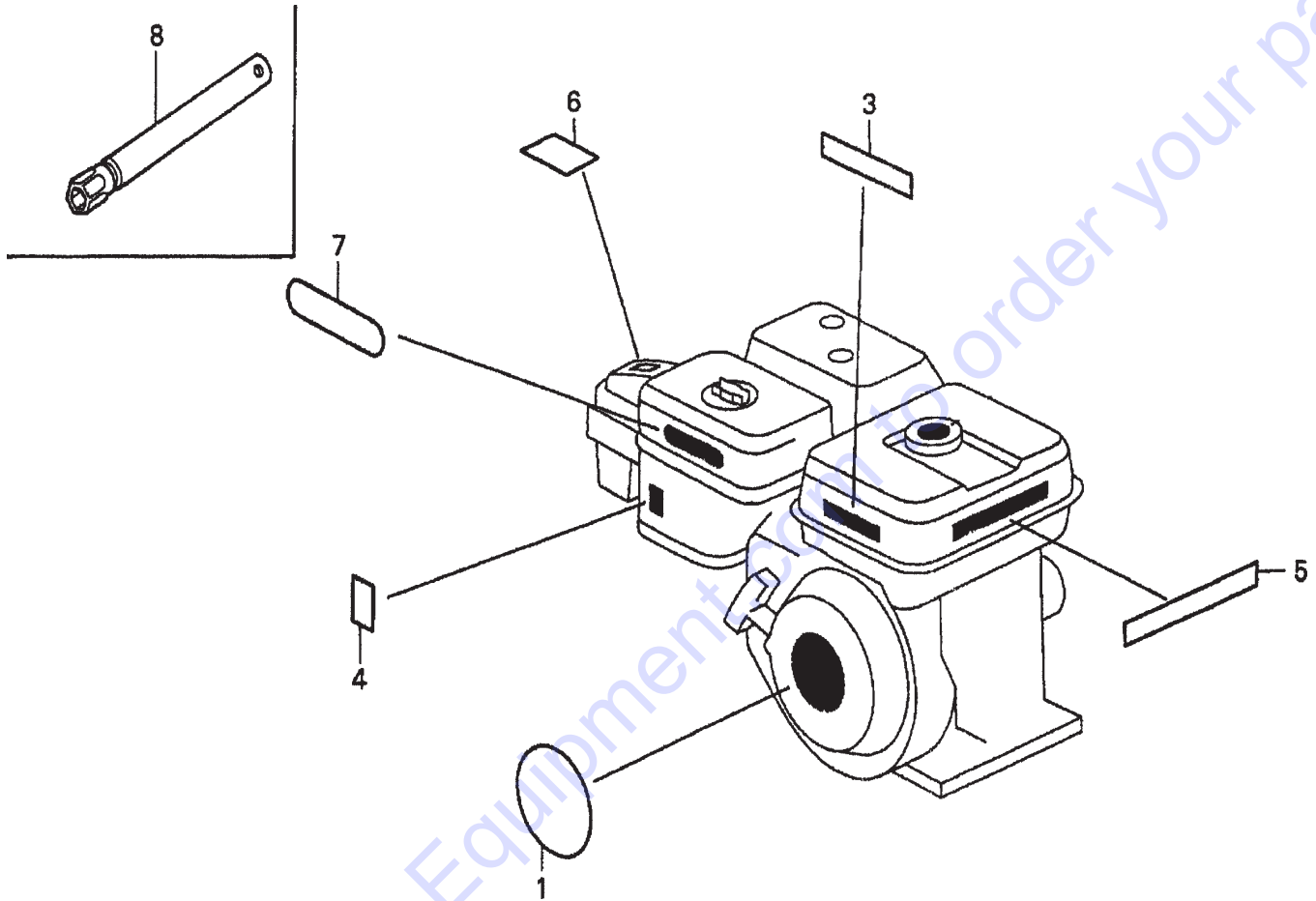

HONDA GX200QXC9 — LABELS ASSY.

LABELS ASSY.

<u>NO.</u>	<u>PART NO.</u>	<u>PART NAME</u>	<u>QTY.</u>	<u>REMARKS</u>
1	87521ZL0010	EMBLEM	1	
3	87522ZH9000	LABEL, CAUTION	1	
4	87528ZE1810	MARK, CHOKE	1	
5	87532ZH8810	MARK, OIL ALERT (E)	1	
6	87534ZE1841	LABEL, AIR CLEANER CAUTION	1	
7	87535ZE1840	MARK, AIR CLEANER SALES POINT	1	
8	89218ZE1000	WRENCH, SPARK PLUG	1	

Go to Discount-Equipment.com to order your parts

PARTS FINDER

**Search Website
by Part Number**



**Search Manual
Library For Parts
Manual & Lookup Part
Numbers – Purchase
or Request Quote**

Search Manuals

Enter your information to help us find the right parts manual for your machine.

* Brand:

* Model:

* Serial:

* Part Number:

SEARCH

**Can't Find Part or
Manual? Request Help
by Manufacturer,
Model & Description**

Parts Order Form

Please fill in the following information to help us find the right part for your machine.

Manufacturer:	<input type="text"/>
Model:	<input type="text"/>
Description:	<input type="text"/>
Part Number:	<input type="text"/>
Quantity:	<input type="text"/>
Notes:	<input type="text"/>

Submit

Discount-Equipment.com is your online resource for quality parts & equipment.

Florida: **561-964-4949** Outside Florida TOLL FREE: **877-690-3101**

Need parts?

Click on this link: <http://www.discount-equipment.com/category/5443-parts/> and choose one of the options to help get the right parts and equipment you are looking for. Please have the machine model and serial number available in order to help us get you the correct parts. If you don't find the part on the website or on one of the online manuals, please fill out the request form and one of our experienced staff members will get back to you with a quote for the right part that your machine needs.

We sell worldwide for the brands: Genie, Terex, JLG, MultiQuip, Mikasa, Essick, Whiteman, Mayco, Toro Stone, Diamond Products, Generac Magnum, Airman, Haulotte, Barreto, Power Blanket, Nifty Lift, Atlas Copco, Chicago Pneumatic, Allmand, Miller Curber, Skyjack, Lull, Skytrak, Tsurumi, Husquvarna Target, Stow, Wacker, Sakai, Mi-T-M, Sullair, Basic, Dynapac, MBW, Weber, Bartell, Bennar Newman, Haulotte, Ditch Runner, Menegotti, Morrison, Contec, Buddy, Crown, Edco, Wyco, Bomag, Laymor, EZ Trench, Bil-Jax, F.S. Curtis, Gehl Pavers, Heli, Honda, ICS/PowerGrit, IHI, Partner, Imer, Clipper, MMD, Koshin, Rice, CH&E, General Equipment, Amida, Coleman, NAC, Gradall, Square Shooter, Kent, Stanley, Tamco, Toku, Hatz, Kohler, Robin, Wisconsin, Northrock, Oztec, Toker TK, Rol-Air, APT, Wylie, Ingersoll Rand / Doosan, Innovatech, Con X, Ammann, Mecalac, Makinex, Smith Surface Prep, Small Line, Wanco, Yanmar