

ESCALATE[®] TRAILER

Model ET 12000 Operation and Service Manual

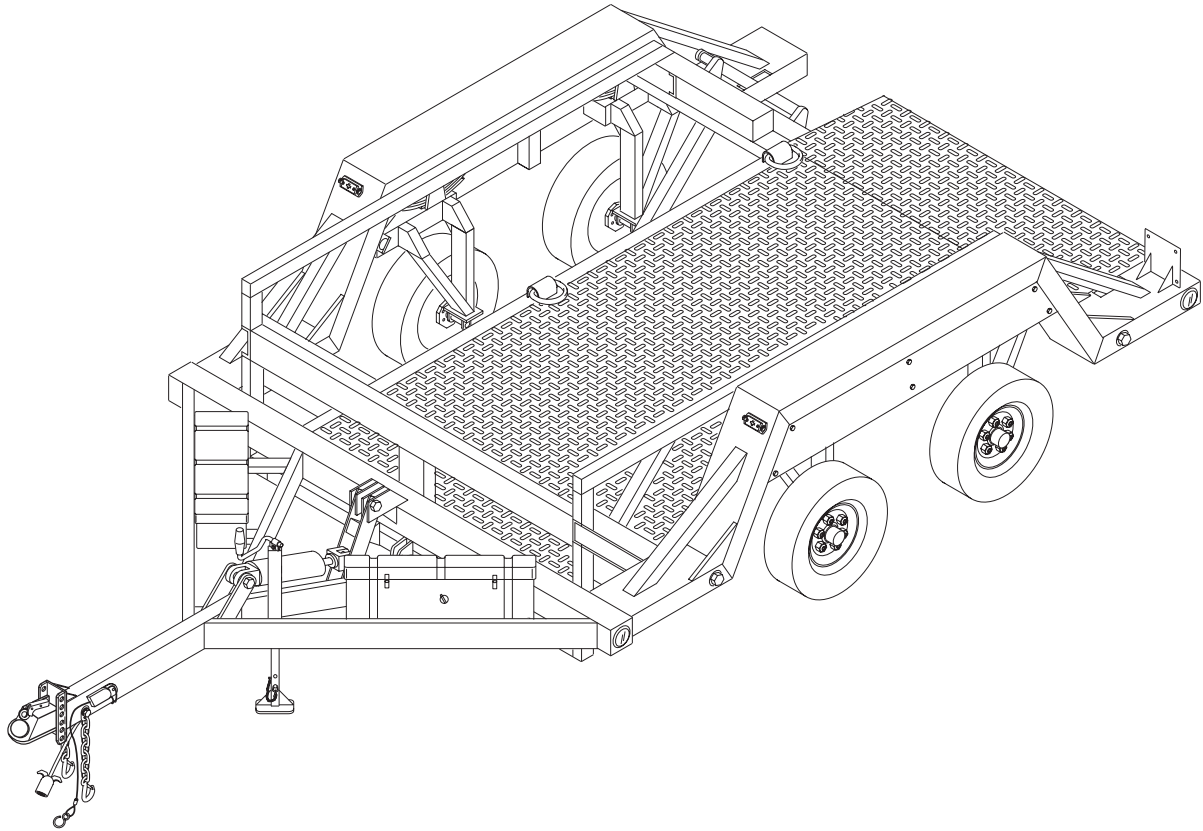

Load Capacity: 12000 lbs

The ET 12000 **ESCALATE[®] TRAILER** offers ground level roll-on loading and roll-off unloading of equipment with non-tilting lowering deck. The hydraulic lift deck allows one person to load and unload equipment.

Contents

SAFETY	2
SPECIAL FEATURES	2
SPECIFICATIONS	3
WARRANTY	3
TRAILER HITCHING	4
EQUIPMENT LOADING	5
SERVICE	7
PARTS LIST	10

SAFETY

Warnings and Cautions

Observe all warning labels on the trailer. The trailer warning labels are shown here as a reminder. Other warnings and cautions are included in this manual.

Failure to observe all warnings may result in serious injury or death. Failure to observe all cautions may result in equipment damage.



SPECIAL FEATURES

The Bil-Jax **ESCALATE**[®] **TRAILER** includes all the features of a heavy duty trailer, plus:

Escalator Deck and Hydraulic Lift

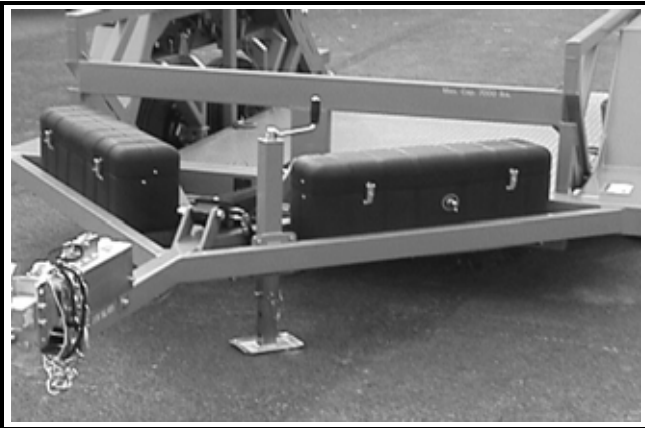

Heavy Duty Tie-Down Brackets



Adjustable Hitch



ESCALATE[®] TRAILER

Model Number ET 12000

Serial Number _____

Manufactured by: Bil-Jax, Inc.
125 Taylor Parkway
Archbold, Ohio 43502
800-537-0540

Specifications

Rated Capacity	12000 lbs. (5443 kg) max.
Weight (Empty)	4500 lbs. (2041 kg)
Overall Width	102 in. (259.1 cm)
Overall Length	263 in. (668.0 cm)
Overall Height (Bed Raised)	56 in. (142.2 cm)
Bed Height (Raised)	13 in. (33.0 cm)
Bed Size (Flat Surface)	75 in. wide x 144 in. long (190.5 cm wide x 365.8 cm long)
Overall Bed Size (Including Ramp)	75 in. wide x 168 in. long (190.5 cm wide x 426.7 cm long)
Ramp Grade	6 degrees
Hitch Size	2-5/16 in. (5.87 cm) ball
Suspension	Tandem Axle Leaf Spring
Brakes	Standard – Electric; Optional – Hydraulic Surge

WARRANTY

Bil-Jax warrants its trailers for one year from the date of delivery against all defects of material and workmanship, provided the unit is operated and maintained in compliance with Bil-Jax's operating and maintenance instructions; structural components are also warranted for one year. Bil-Jax will, at its option, repair or replace any unit or component part which fails to function properly in normal use.

This warranty does not apply if the trailer and/or its component parts have been altered, changed, or repaired without the consent of Bil-Jax or by anyone other than Bil-Jax or its factory trained personnel, nor if the trailer and/or its components have been subjected to misuse, negligence, accident or any conditions deemed other than those considered as occurring during normal use.

Components not manufactured by Bil-Jax are covered by their respective manufacturers warranties. A list of those components and their warranties is available upon written request to Bil-Jax.

Bil-Jax shall not in any event be liable for the cost of any special, indirect or consequential damages to anyone, product, or thing. This warranty is in lieu of all other warranties expressed or implied. We neither assume nor authorize any representative, or other person, to assume for us any other liability in connection with the sale, rental, or use of this product.

TRAILER HITCHING

Hook Up the Trailer

1. Raise trailer and open ball latch.

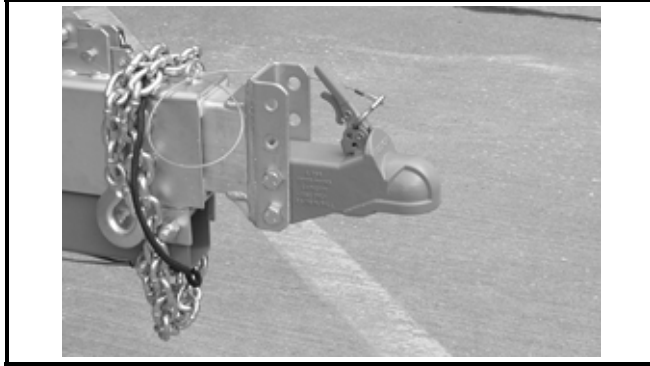

NOTE: The trailer hitch uses a 2-5/16 inch ball.

2. Line up ball with hitch.

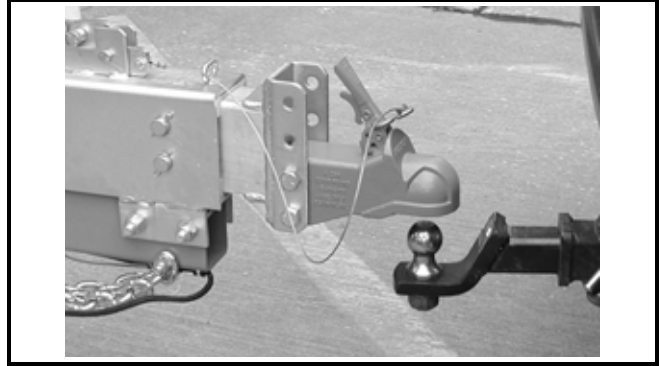

CAUTION

2-5/16 inch ball on tow vehicle must have a 20,000 lb. capacity rating.

3. Lower hitch onto ball and close ball latch.

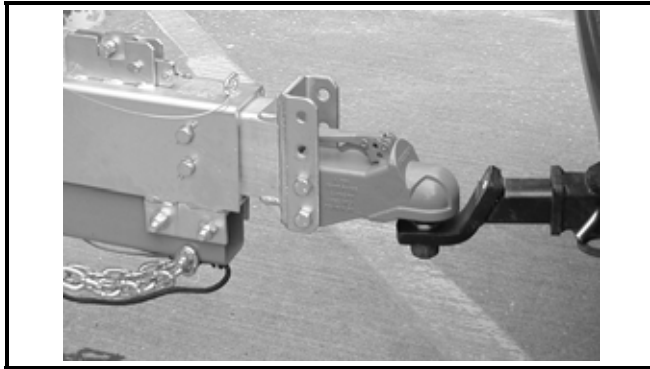

NOTE: Trailer frame should be level when hitch is on ball. See page 10 to adjust hitch height.

4. Raise the jack.



CAUTION

Always raise the jack before towing.

5. Hook safety chains and attach breakaway cable.

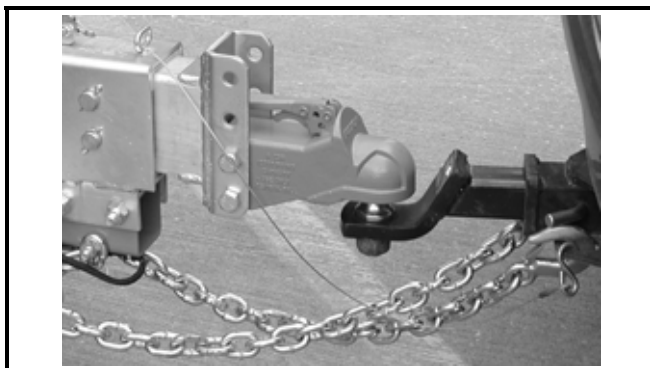

CAUTION

Always cross safety chains below tongue. Safety chains must hold tongue up if hitch fails.

6. Connect and check trailer lights.

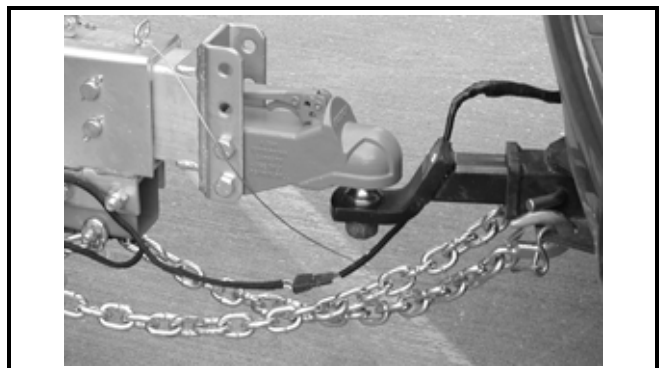

CAUTION

Always check the tail lights and brake lights before towing.

EQUIPMENT LOADING

Lower the Deck

NOTE: Trailer must be hitched to vehicle according to page 5 before lowering or raising the deck.

1. Turn power switch to ON position.
2. Hold control lever in the direction shown until the deck reaches ground level, then release.



NOTE: The trailer should be on a level surface when lowering the deck.

Load the Equipment

1. Load equipment so that the resulting tongue weight is 15 to 20% of the total load.
2. Install tie-down straps to keep the load from shifting. Use 8 tie-down anchors shown.

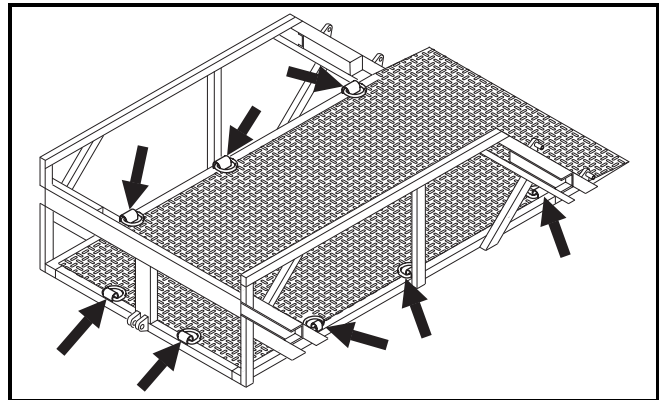
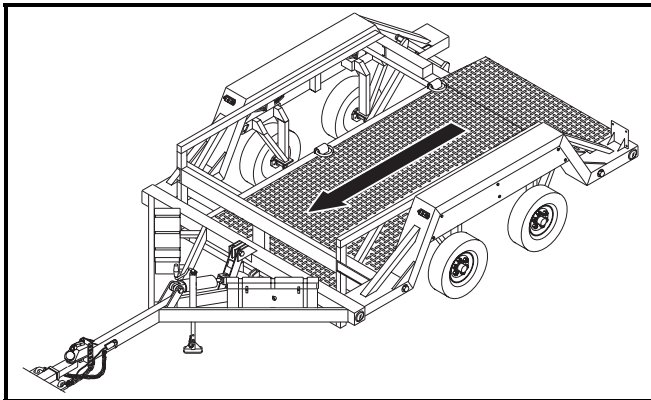

WARNING

Maximum capacity = 12000 lbs. Do not exceed.



WARNING

Always secure the load with tie-down straps before towing. Failure to properly secure the load may result in injury, death, or equipment damage.



CAUTION

Do not hook tie-down straps on the roller guides.

Raise the Deck (trailer must be hitched to vehicle)

1. Turn power switch to ON position. Hold control lever in the direction shown. Release control lever when deck is in fully raised position.
2. Turn power switch to OFF position.





⚠ WARNING

Make sure people are away from the trailer before raising the deck. Keep hands and feet away from deck and rails. Hands and feet can get crushed between the deck and frame.

Tire Maintenance

At least once each week, use an accurate tire pressure gage to check the air pressure in all four trailer tires. Inflate to the pressure recommended by the tire manufacturer (located on the tire).

 CAUTION
Low or uneven tire pressures will not properly support a loaded trailer and could lead to premature tire wear.
 WARNING
When replacing tires, it is important to use a tire of appropriate size and load rating (LT215/75R17.5).
 WARNING
Failure to maintain proper torque on the lug nuts may result in the wheel shearing off of the trailer, possibly causing an accident and seriously damaging the equipment.

Wheel Torque Requirements

It is extremely important to apply and maintain proper wheel mounting torque on your axle. Wheel nuts should be retorqued after 50 miles and 100 miles and periodically there after.

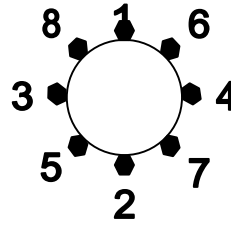

The tightening of the lug nuts should be torqued in the sequence above.

Lug nuts should be torqued in stages:

Stage 1	Stage 2	Stage 3
75 Ft-Lbs	150 Ft-Lbs	300 Ft-Lbs

This procedure should be followed after each time the tire is removed.

Lubrication (every 6 months)

Lubricate the following parts with clean motor oil where shown.

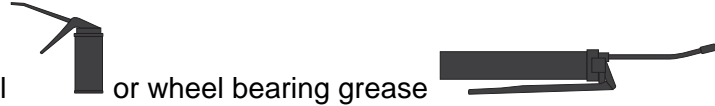

Lift Bearings



Jack



Hitch



Hydraulic Fluid Levels

1. Open cover enclosing hydraulic pump. Check fluid level in hydraulic reservoir. When trailer deck is fully raised, hydraulic fluid level should be approximately 1 inch above 1/2 of reservoir volume.
2. If reservoir volume is below 1/2 when trailer deck is fully raised, add enough BP type HLP-46 or 10W hydraulic oil to bring fluid level in reservoir to approximately 1 inch above 1/2 full.



Batteries

1. Use hydrometer to check charge in batteries daily or weekly, depending on frequency of use. If the charge drops below 25% of full charge (S.G. below 1.155 as corrected to 80°F) the batteries must be recharged. Refer to step 2 before charging batteries.
2. Check the electrolyte level weekly. If battery charge is low, add water to bring electrolyte level just above plates.
3. Charge batteries at one of the following charge rates. The slow charge rate is preferred.
 - 22 hours @ 5 amps
 - 5 hours @ 20 amps
 - 2 hours @ 50 amps

If batteries are fully charged, add water to raise electrolyte to full mark in each cell.

Adjusting the Hitch Height

The trailer frame and deck should be level for equipment loading and unloading. If the trailer hitch is too high or too low when hitched to the towing vehicle, readjust the hitch height.

1. Unhitch trailer. Remove hitch mounting bolts and nuts.



CAUTION

Adjust hitch height when trailer is empty. Use jack to aid in hitch adjustment.

2. Install hitch in new position.



CAUTION

Failure to install and tighten all 4 hitch mounting bolts may cause serious equipment damage.

This page intentionally left blank

PARTS LIST

Model ET 12000 ESCALATE[®] TRAILER, Hitch Section

Item No.	Part No.	Description	Qty
1	0090-0346	Screw, Self-tapping, #10-24 x 3/4	8
2	B01-10-0179	Side Marker, Amber, Ear Mount – Front	2
2A	B01-10-0241	Side Marker, Red, Ear Mount – Rear	2
3	B01-10-0153	Plug Assembly, Marker Lights	2
4	B01-10-0152	Grommet, 2-1/2 inch	2
5	B01-10-0151	Side Light, Amber, 2-1/2 inch	2
6	0090-0344	Screw, Self-tapping, #10-24 x 1/2	2
7	0090-0042	Screw, Cap, 3/8-16 x 1	4
8	0090-0188	Nut, Lock, 3/8-16	4
9	B12-00-0166	Outer Tube Weldment, Jack	1
10	B23-02-0062	Tongue Jack Assembly (includes items 11 through 17)	1
11	B23-02-0066	Drop Leg, Quick Adjust	1
12	B25-00-0068	Kit, Bearing	1
13	B04-06-0030	Washer, 2.18 inch Square	1
14	B46-00-0028	Kit, Handle Replacement (includes items 15 & 16)	1
15	0090-0007	Screw, Cap, 1/4-20 x 1-1/4	1
16	0090-0183	Nut, Lock, 1/4-20	1
17	B36-00-0039	Pin	1
18	B03-00-0017	Safety Chain Assembly	2
19	0090-0081	Bolt, 1/2-13 x 5	1
20	0090-0574	Washer, Flat, 1/2	2
21	0090-0192	Nut, Lock, 1/2-13	1
22	B01-01-0141	Wiring Harness, Electric Brake	1
23	B12-00-0167	Coupler, 2-5/16 inch	1
24	B01-02-0062	Switch, Breakaway	1
25	0090-1001	Bolt, 5/8-11 x 1-3/4	4
26	0090-0194	Nut, Lock, 5/8-11	4
27	0090-0513	Screw, Self-tapping, 1/4-28 x 1/2	1
28	B04-07-0032	Clamp, Hose	13
29	0090-0183	Nut, Lock, 1/4-20	13
30	B06-00-0357	Transfer, 2-5/16 Ball Hitch	1

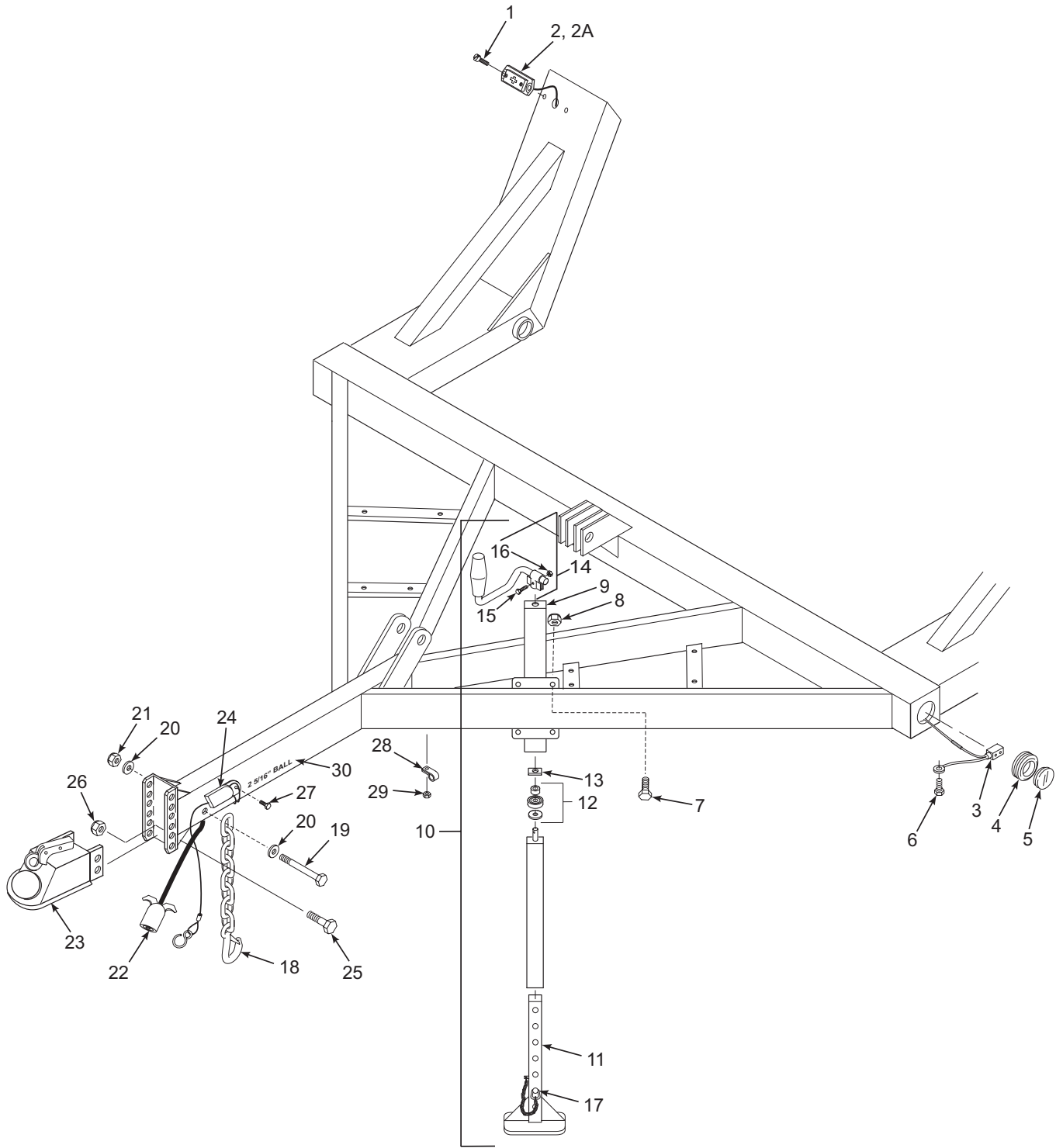

Model ET 12000 ESCALATE® TRAILER, Hitch Section

PARTS LIST

Model ET 12000 ESCALATE® TRAILER, Lift Section

Item No.	Part No.	Description	Qty
1	B02-05-0028	Pump Unit, Hydraulic, Manual Valve	1
2	B02-01-0147	Hose, Hydraulic	2
3	B02-02-0012	Fitting, Hydraulic	2
4	B01-04-0001	Battery, 6 V, 190 Amp	2
5	B01-01-0010	Battery Cable, 13 inch	2
6	B01-01-0067	Battery Cable, 60 inch	1
7	0090-0160	Nut, Hex, 5/16-18	4
8	B01-01-0013	Battery Cable, 30 inch	1
9	B07-06-5882	Strap, Battery Hold Down	2
10	B04-07-0003	Rod, Battery Hold Down, 1/4-20 x 10	4
11	B18-00-0147	Box w/Lid, Battery/Pump	2
12	B42-01-1014	Hinge, Continuous	2
13	0090-0236	Screw, Machine, #10-24 x 3/4	40
14	0090-0415	Washer, Flat, #10	96
15	0090-0182	Nut, Lock, #10-24	48
16	B42-00-0018	Latch, Draw	4
17	0090-0813	Screw, Machine, #8-32 x 3/4	20
18	0090-0181	Nut, Lock, #8-32	20
19	B01-02-0060	Switch, Master Power	1
20	B00-00-0112	Face Plate, Power Switch	1
21	B01-09-0018	Boot, Terminal	2
22	0090-0816	Nut, Hex, 5/16-24	1
23	B42-00-0019	Keeper, Draw Latch	4
24	0054-092	Cable, Lid	4
25	0090-0232	Screw, Machine, #10-24 x 5/8	8
26	0090-0183	Nut, Lock, 1/4-20	4
27	0090-0419	Washer, Flat, 1/4	4
28	0090-0042	Screw, Cap, 3/8-16 x 1	6
29	0090-0210	Washer, Lock, 3/8	2
30	0090-0422	Washer, Flat, 3/8	4
31	0090-0997	Screw, Cap, 1-8 x 9	3
32	0090-0429	Washer, Flat, 1	10
33	0090-0689	Nut, Lock, 1-8	5
34	B12-00-0162	Linkage	1
35	B12-00-0161	Linkage Plate Weldment	1
36	0090-0998	Screw, Cap, 1-8 x 10	1
37	0090-0901	Screw, Cap, 1-8 x 6-1/2	1
38	B02-03-0031	Hydraulic Cylinder	1
38A	B02-13-0123	Seal Kit, Hydraulic Cylinder	1
39	B02-02-0084	Fitting, Hydraulic	2
40	0090-0188	Nut, Lock, 3/8-16	2

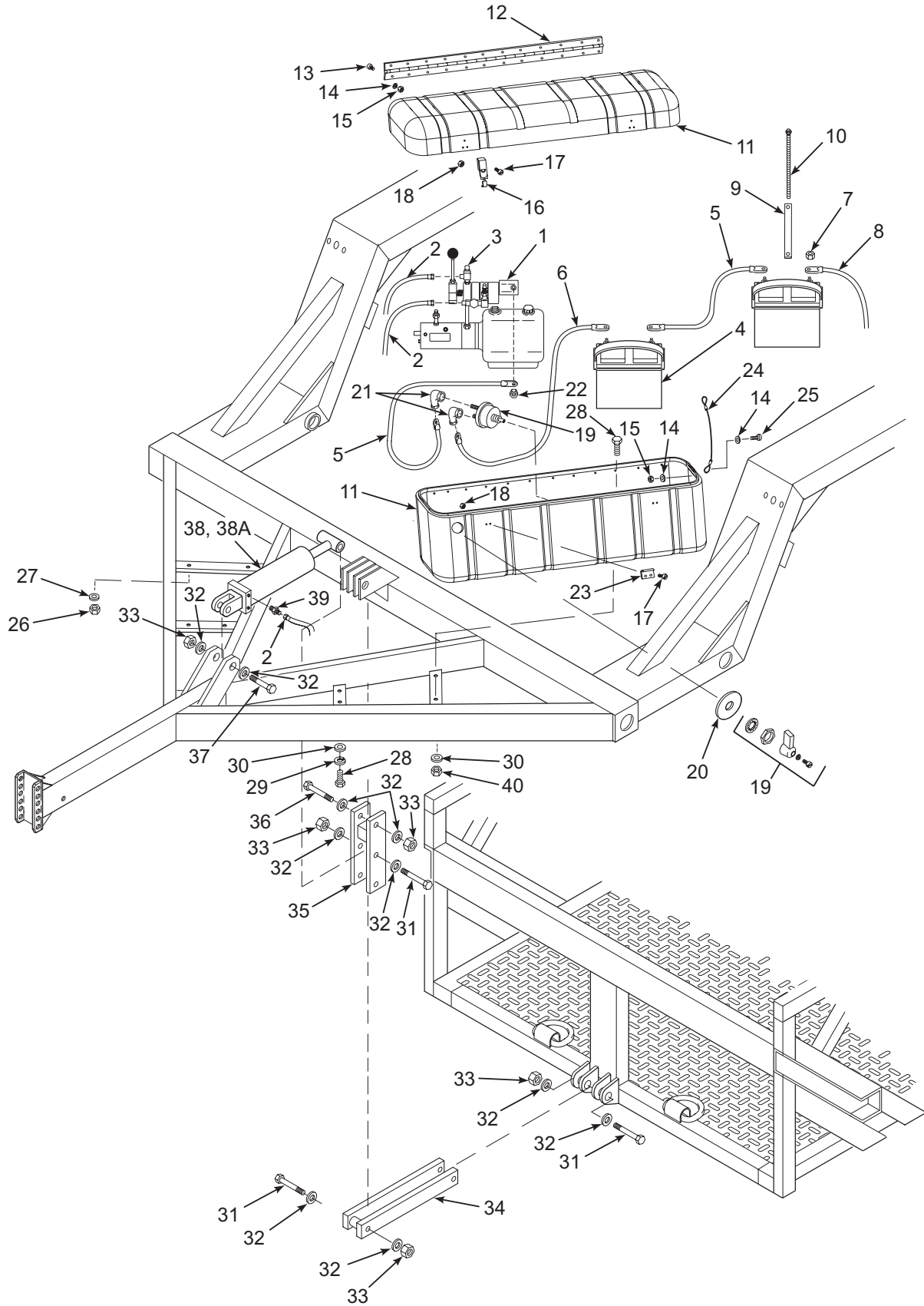

Model ET 1200 ESCALATE® TRAILER, Lift Section

PARTS LIST

Model ET 12000 ESCALATE[®] TRAILER, Deck and Frame Section

Item No.	Part No.	Description	Qty	Item No.	Part No.	Description	Qty
1	B12-00-0158	Deck Weldment	1	33	0090-1003	Nut, Lock, 1/2-20	16
2	B12-00-0163	Bar, Guide	2	34	B12-00-0152	Dust Shield	4
3	0090-0428	Washer, Flat, 3/4	8	35	0090-1002	Screw, Cap, 1/2-20 x 1-3/4	16
4	0090-0103	Screw, Cap, 3/4-10 x 2-1/2	4	36	B12-00-0153	Wire Grommet	4
5	B31-00-0029	Wear Pad, Guide Bar	2	37	B12-00-0148	Electric Brake Assembly, Left Hand	2
6	B12-00-0155	Frame Weldment	1	37A	B12-00-0147	Electric Brake Assembly, Right Hand	2
7	0090-0509	Screw, Cap, Nylon, 3/8-16 x 3/8	8	38	B12-00-0151	Hub-Drum Assembly	4
8	B01-10-0235	Tail Light, Oval	2	39	0090-0994	Washer, Spindle	4
9	B01-10-0237	Plug, 3 Way, Oval	2	40	0090-0993	Nut, Lock, 1-14	4
10	B01-10-0236	Grommet, Oval	2	41	B06-00-0446	Decal, Torque Setting	4
11	B01-10-0153	Plug Assembly, Marker Lights	2	42	B12-00-0154	Cap, Grease	4
12	B01-10-0239	Grommet, 2 inch	2	43	B08-02-0016	Wheel Assembly, LT215/75R17.5	4
13	B01-10-0238	Side Light, Red, 2 inch	2	44	0090-0995	Nut, Wheel Lug	32
14	0090-0344	Screw, #10-24 x 1/2	2	45	B30-00-0051	Plate, Wear	2
15	B07-07-5029	Block, Suspension Pin	8	46	0090-0422	Washer, Flat, 3/8	8
16	B07-07-1023	Suspension Pin	4	47	0090-0042	Screw, Cap, 3/8-16 x 1	8
17	B07-06-5697	Suspension Pin Plate	8	48	B12-00-0121	Roller, Lift	4
18	0090-0988	Screw, Cap, 5/8-11 x 3-1/2, Grade 8	16	49	0090-0954	Screw, Cap, 1-8 x 11	4
19	B39-00-0044	Leaf Spring, Slipper	4	50	B04-07-0117	Shaft, Cam Follower	4
20	B12-00-0164	Hanger, Leaf Spring	4	51	0090-0949	Screw, Nylon, 1-8 x 1/2	4
21	B39-00-0045	Hanger Kit, Tandem Slipper Spring	2	52	B07-05-0115	Fender	2
22	B07-07-5037	Strap, Leaf Spring	8	53	0090-0013	Screw, Cap, 1/4-20 x 2-1/4	8
23	0090-0058	Screw, Cap, 3/8-16 x 4	16	54	0090-0419	Washer, Flat, 1/4	16
24	B07-07-5035	Block, Leaf Spring Clamp	4	55	0090-0183	Nut, Lock, 1/4-20	8
25	0090-0633	Screw, Cap, 5/8-11 x 1-1/2	8	56	B06-00-0161Y	Transfer, Bil-Jax	2
26	0090-0422	Washer, Flat, 3/8	16	57	B06-00-0447	Transfer, 12000# Max.	1
27	0090-0188	Nut, Lock, 3/8-16	16	58	Not Replaceable	Plate, Serial #	1
28	B12-00-0160	Suspension Arm, Right Rear, Left Front	2	59	B06-00-0312	Decal, "Moving Deck..."	2
29	0090-0195	Nut, Lock, 3/4-10	4	60	B06-00-0448	Transfer, "ET 12000"	2
30	0090-0428	Washer, Flat, 3/4	8	61	B06-00-0317	Decal, Escalate Trailer Logo	2
31	0090-0999	Screw, Cap, 3/4-10 x 7	4	62	B06-00-0313	Decal, "Stand Clear..."	2
32	B12-00-0159	Suspension Arm, Right Front, Left Rear	2	Ref.	B01-10-0240	Bracket, License Plate, with Lamp	

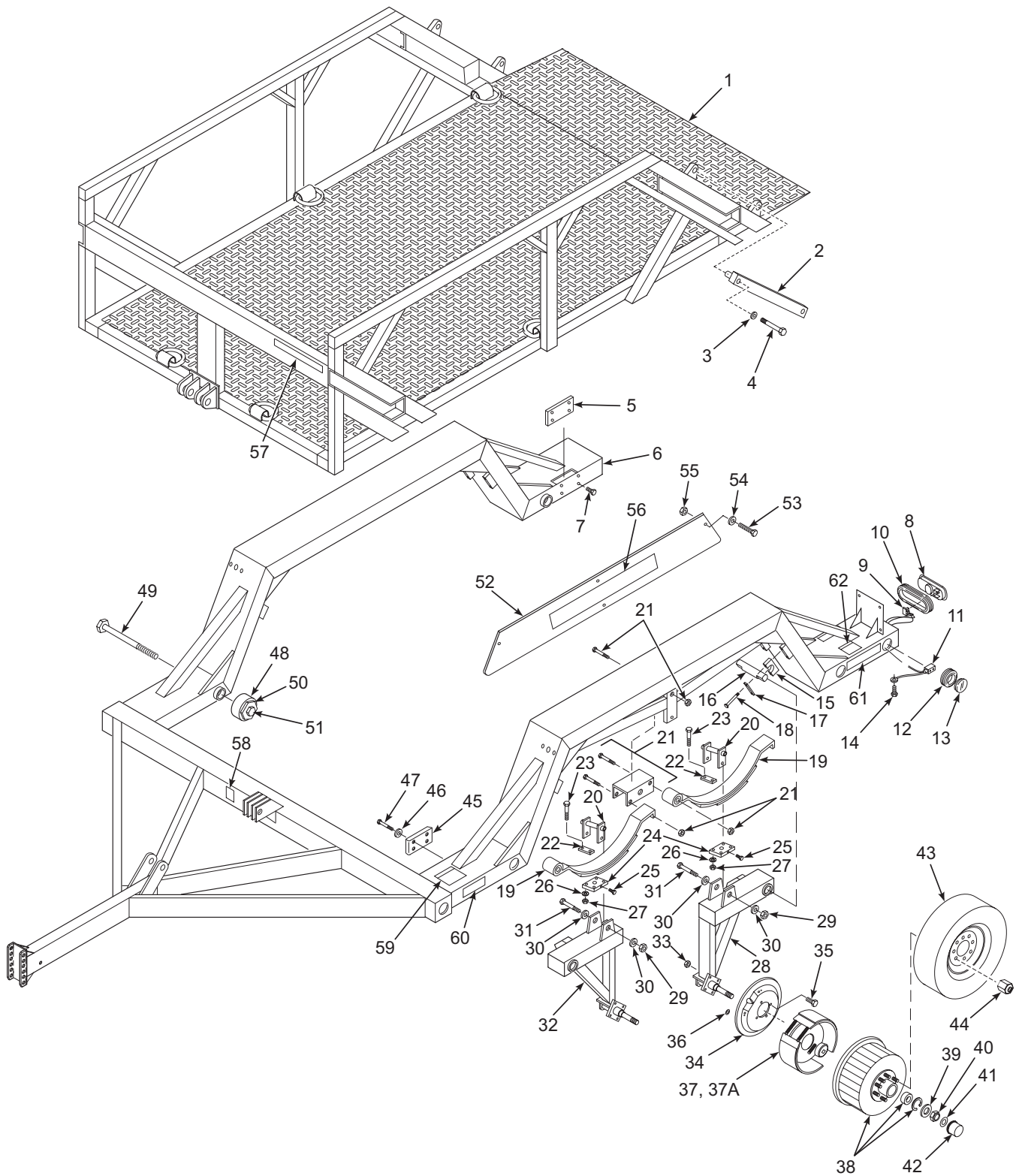

Model ET 12000 ESCALATE[®] TRAILER, Deck and Frame Section

PARTS LIST

B02-05-0028 Hydraulic Pump Assembly

Item No.	Part No.	Description	Qty
1	B02-15-0398	Motor, DC - 12V	1
2	B02-15-0399	Pump Assembly	1
3	B02-15-0400	Tank, Plastic	1
4	B02-15-0401	Tube, Interior Return	1
5	B02-15-0402	Tube, Relief Valve Return	1
6	B02-15-0403	Tube, Suction	1
7	B02-15-0404	Filter, Suction	1
8	0090-0975	Bolt, Socket Head, 1/4-20 x 3	4
9	B02-15-0405	Valve Assembly (includes items 10 & 11)	1
10	B02-15-0406	Switch Assembly Cam (includes item 11)	1
11	B02-15-0407	Contact, Start Switch	1
12	B02-15-0408	Elbow, 90 Degree, 3/8 Tube x 1/4 NPT	1
13	B02-15-0409	Adapter, Pump/Valve, 2-1/2 Long	1
14	B02-15-0410	Valve, Check	1
15	B02-15-0411	Handle Assembly	1
16	B02-15-0412	Clamp	1
17	B02-15-0413	Tube, Exterior Return	1
18	B02-15-0414	Connector Assembly	1
19	B02-15-0415	Valve, Relief	1
20	B02-15-0416	Bracket, Plate Mount, 3-1/4 Hole Spacing	1
21	0090-0976	Bolt, Socket Head, 3/8-16 x 1	2
22	B01-01-0010	Cable, 2GA x 13, Eyelet Ends	1
23	B02-15-0417	Base Assembly	1
24	B02-15-0418	Cap, Fill	1

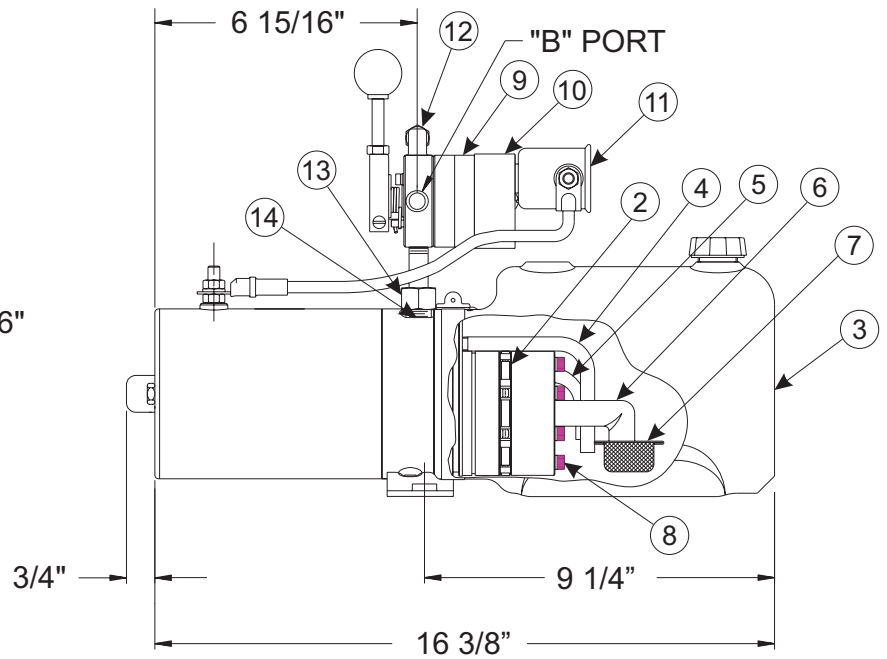
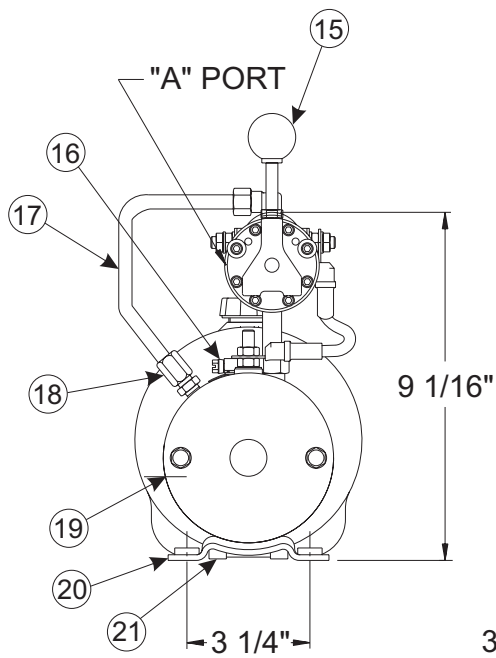
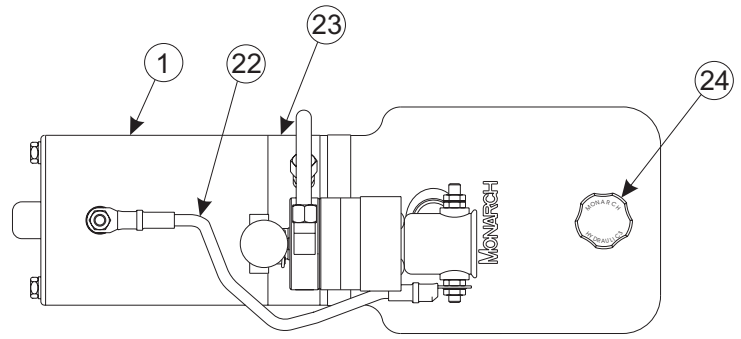

B02-05-0028 Hydraulic Pump Assembly