



SERVICE/PARTS MANUAL

**MODELS: 1050PM, 1265PM, 1285PM &
1650PM**



PLASTER/MORTAR MIXER

A 100% employee-owned American manufacturer

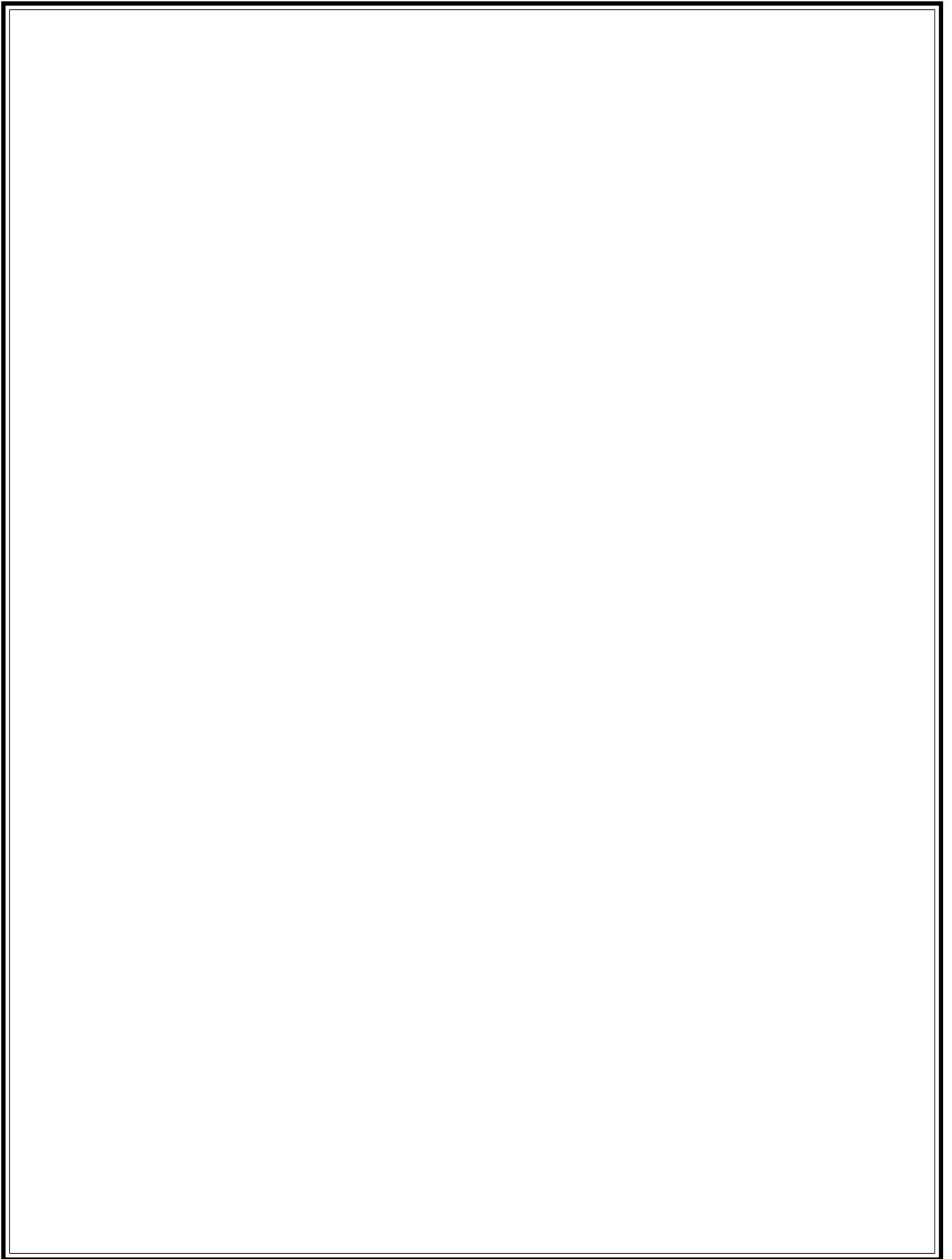

Table of Contents

**1050PM, 1265PM,
1285PM, 1650PM**

TABLE OF CONTENTS	3-4
FOREWORD / SERVICE INFORMATION	5
Limited WARRANTY	6
TECHNICAL DATA	7-10
Specifications	7
Imperial Torque Chart	8
Metric Torque Chart	9
Hardware Identification	10
HEALTH & SAFETY	11-15
Safety Training	1
Safety Precautions	12-15
MAINTENANCE	16-24
Maintenance Tasks	16
Hardware	17
Fuel	17
Location and Use of Controls	17
Wheel Bearing Lubrication	18
Wheel Bearing Adjustment	18
Hardware	18
Cleaning	19
Safety Chain / Towing	19-20
Bearing and Seal Installation	21
Bull Gear Assembly	22
Maintenance Chart	23
Gearcase Clutch Assembly	24

Table of Contents

**1050PM, 1265PM,
1285PM, 1650PM**

EXPLODED DIAGRAM AND PARTS LIST	25-71
Frame and Drum Assembly - 1050PM.....	26-29
Frame and Drum Assembly - 1265PM, 1285PM and 1650PM	30-33
Paddle Assembly - 1050PM	34-35
Paddle Assembly - 1265PM and 1285PM	36-37
Paddle Assembly - 1650PM	38-39
Electric Motor Drive Train - 1050PM	40-43
Electric Motor Drive Train - 1265PM	44-45
Gas Engine Drive Train 1050PM/1265PM	46-49
Clutch Assembly - 1050PM	50-51
Clutch Assembly - 1265PM	52-53
Gearcase Assembly - 1285PM and 1650PM.....	54-59
Clutch Assembly - 1285PM and 1650PM.....	60-61
Spring Axle Assembly	62-63
Trialer Lights Assembly Option	64-65
Exhaust Systems	66-67
Electric Wiring	68-69
Decal Identification	70-71
 CALIFORNIA PROPOSITION 65 WARNING	 IBC

MANUFACTURED UNDER ONE OR MORE OF THE FOLLOWING PATENTS AND OTHERS PENDING: 3761058, 3905519, 3931748, 3932006, 4043540, 4180281.

Technical Data

1050PM, 1265PM, 1285PM & 1650PM – Specifications

MODEL	STONE 1050PM	STONE 1265PM	STONE 1285PM	STONE 1650PM
<u>Dimensions</u>				
Operating Wt. lbs. / kg	875 / 396,9	1085 / 492,1	1120 / 508	1267 / 574,7
Batch Capacity Bags	2 ½ - 3 ½	3 - 4	3 - 4	4 ½ - 5 ½
Batch Capacity cu. ft. / m ³	10 / ,28	12 / ,34	12 / ,34	16 / ,45
Total Volume cu. ft. / m ³	11.5 / ,33	14.8 / ,42	14.8 / ,42	19.5 / ,55
Shipping Dimensions L x W x H / cm	75 x 56 x 59 190,5 x 142,2 x 150	81 x 56 x 59 205,7 x 142,2 x 150	81 x 56 x 59 205,7 x 142,2 x 150	81 x 56 x 59 233,7 x 142,2 x 150
Engine	10 hp B&S, 8.5 hp Robin, 11 hp Honda, 8 hp B&S I/C, 8 hp B&S I/P 3 hp Electric	10 hp B&S, 11 hp Honda, 3 hp Electric	11 hp Robin, 11 hp Honda, 18 hp B&S I/C, 5 hp Electric	11 hp Robin, 11 hp Honda, 18 hp B&S I/C, 5 hp Electric
Drive & Clutch	V-belts to Gears Front Post Hand Clutch	V-belts to Gears Front Post Hand Clutch	Totally enclosed gear drive & clutch (no chain or belt)	Totally enclosed gear drive & clutch (no chain or belt)

Mortar Mixer Features: Bag Splitter, Safety Guard, Patented Guard Lifter, Safety Chain

Technical Data

Torque Chart - Imperial

SAE GRADE 5 Coarse Thread, Zinc-Plated		
SIZE	TORQUE	
	ft. lbs.	Nm
1/4 - 20 (.250)	6	8
5/16 - 18 (.3125)	13	18
3/8 - 16 (.375)	23	31
7/16 - 14 (.4375)	37	50
1/2 - 13 (.500)	57	77
9/16 - 12 (.5625)	82	111
5/8 - 11 (.625)	112	152
3/4 - 10 (.750)	200	271
7/8 - 9 (.875)	322	436.5
1 - 8 (1.000)	483	655

SAE GRADE 8 Coarse Thread, Zinc-Plated		
SIZE	TORQUE	
	ft. lbs.	Nm
1/4 - 20 (.250)	9	12
5/16 - 18 (.3125)	18	24
3/8 - 16 (.375)	33	45
7/16 - 14 (.4375)	52	70
1/2 - 13 (.500)	80	108
9/16 - 12 (.5625)	115	156
5/8 - 11 (.625)	159	215
3/4 - 10 (.750)	282	382
7/8 - 9 (.875)	454	615
1 - 8 (1.000)	682	925

SAE GRADE 5 Fine Thread, Zinc-Plated		
SIZE	TORQUE	
	ft. lbs.	Nm
1/4 - 28 (.250)	7	10
5/16 - 24 (.3125)	14	19
3/8 - 24 (.375)	26	35
7/16 - 20 (.4375)	41	56
1/2 - 20 (.500)	64	87
9/16 - 18 (.5625)	91	123
5/8 - 18 (.625)	128	173
3/4 - 16 (.750)	223	302
7/8 - 14 (.875)	355	481
1 - 12 (1.000)	529	717
1 - 14 (1.000)	541	733

SAE GRADE 8 Fine Thread, Zinc-Plated		
SIZE	TORQUE	
	ft. lbs.	Nm
1/4 - 28 (.250)	10	14
5/16 - 24 (.3125)	20	27
3/8 - 24 (.375)	37	50
7/16 - 20 (.4375)	58	79
1/2 - 20 (.500)	90	122
9/16 - 18 (.5625)	129	175
5/8 - 18 (.625)	180	244
3/4 - 16 (.750)	315	427
7/8 - 9 (.875)	501	679
1 - 12 (1.000)	746	1011
1 - 14 (1.000)	764	1036

document in lgpm.p65

Technical Data

Torque Chart - Metric

Property Class 8.8

ZINC-PLATED

SIZE	Coarse Thread		Fine Thread	
	Nm	ft. lbs.	Nm	ft. lbs.
M6	9.9	7	10	7
M8	24	18	25	18
M10	48	35	49	36
M12	83	61	88	65
M14	132	97	140	103
M16	200	148	210	155
M20	390	288	425	313
M24	675	498	720	531

Property Class 10.9

ZINC-PLATED

SIZE	Coarse Thread		Fine Thread	
	Nm	ft. lbs.	Nm	ft. lbs.
M6	14	10	14	10
M8	34	25	35	26
M10	67	49	68	50
M12	117	86	125	92
M14	185	136	192	142
M16	285	210	295	218
M20	550	406	600	443
M24	950	701	1000	738

Property Class 12.9

ZINC-PLATED

SIZE	Coarse Thread		Fine Thread	
	Nm	ft. lbs.	Nm	ft. lbs.
M6	16.5	12	16.5	12
M8	40	30	42	31
M10	81	60	82	60
M12	140	103	150	111
M14	220	162	235	173
M16	340	251	350	258
M20	660	487	720	531
M24	1140	841	1200	885

Conversion Factor: 1 ft. lb. = 1.3558 Nm

Technical Data

Hardware Identification

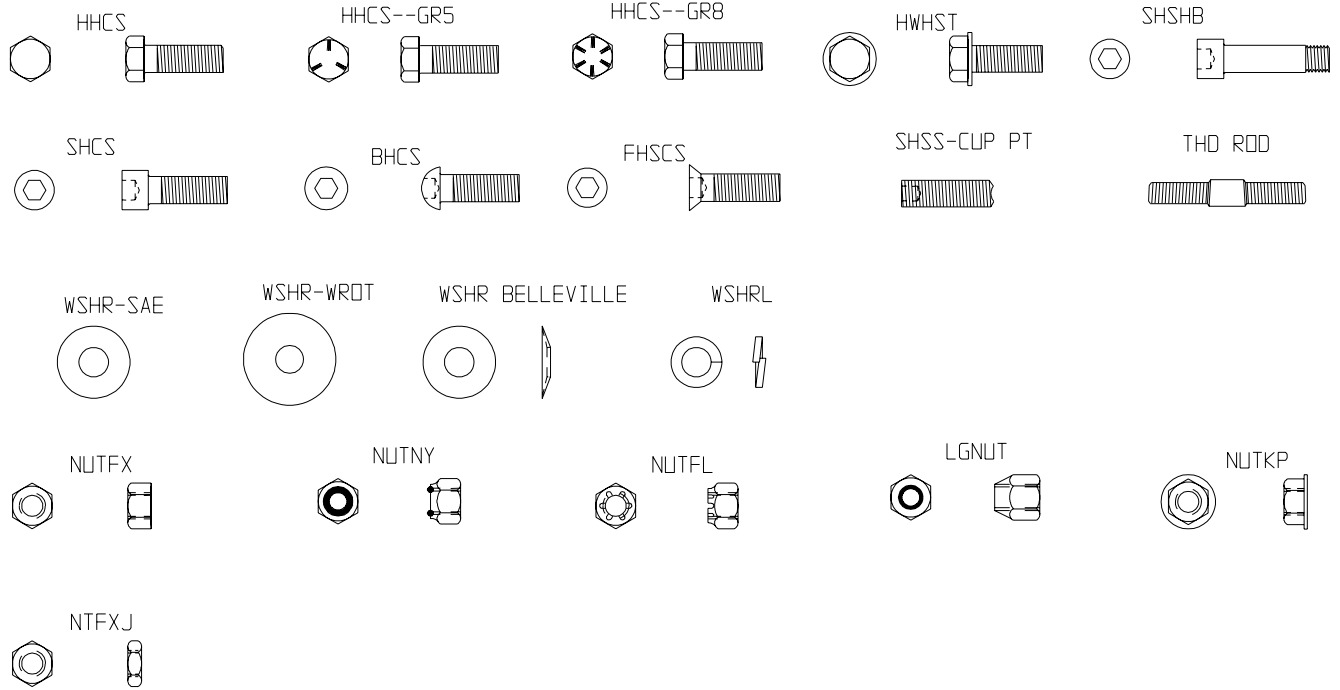

SAFETY

These machines are designed to carry out the function of mixing material of the non-cohesive, bituminous and granular varieties.

If used correctly, they will provide an effective and safe means of mixing and meet the appropriate performance standards.

It is essential that the operator of the machine is adequately trained in its safe operation, be authorized to operate it, and have sufficient knowledge of the machine to ensure that it is in full working order, before being put to use.



- Before using this equipment, study the entire Owner's Manual to become familiar with its operation. Do not allow untrained or unauthorized personnel, especially children, to operate this equipment. Use only factory authorized parts for service.



- When warning decals are destroyed or missing, contact the Manufacturer immediately at 1-800-888-9926 for replacement. For the safety of yourself and others, it is imperative that the following rules are observed. Failure to do so may result in serious injury or death.



- This notation appears before warnings in this manual. It means that the following steps must be carried out to avoid the possibility of personal injury or death. These warnings are intended to help the technician avoid potential hazards encountered in normal service procedures. We strongly recommend the reader take advantage of the information provided to prevent personal injury or injury to others.

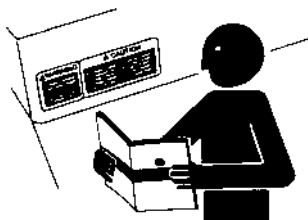

Follow Safety Instructions

- Carefully read all safety messages and decals in this manual and on your machine safety signs. Keep decals in good condition. Replace missing or damaged decals. Be sure new equipment components and repair parts include the current safety signs. Replacement safety signs and decals are available through your dealer.
- Learn how to operate the machine and how to use controls properly. Do not let anyone operate without instruction.
- Keep your machine in proper working condition. Unauthorized modifications to the machine may impair the function and/or safety and affect machine life.
- If you do not understand any part of this manual and need assistance, contact your dealer.



DANGER
WARNING
CAUTION

Understand Signal Words

- A signal word – **DANGER**, or **CAUTION** – is used with the safety-alert symbol. **DANGER** identifies the most serious hazards.
- **DANGER** or **WARNING** safety signs are located near specific hazards. General precautions are listed on **CAUTION** safety signs. **CAUTION** also calls attention to safety messages in this manual.



Warning - Loose Hardware

- With power off, daily check for loose hardware. Immediately inform your supervisor to have it corrected--Do Not Run the Mixer.



Warning-Handling Fuel

- Transport and handle fuel only when contained in approved safety containers.
- Do not smoke when refueling the mixer or during any other fuel handling operation.
- Do not refuel the mixer with the unit running or while hot.
- If fuel is spilled during refueling, wipe it off the engine immediately and discard the rag in a safe place.
- Do not operate the equipment if fuel or oil leaks exist – repair immediately.
- Never operate this equipment in an explosive atmosphere.



Warning-Operating

- Never perform any work on the mixer while it is running.
- Before working on the mixer, stop the engine and disconnect the spark plug wire(s) to prevent accidental starting. If electric, unplug motor.
- Keep cowl closed during operation.
- Keep hands, clothing and jewelry away from all moving parts.
- Keep all guards in place, including drum guards.
- Never stick your hands or any solid object into the drum while it is in operation.



Warning-Hot Surfaces

- Avoid contact with hot exhaust system and engines.
- Allow engine to cool before performing any repairs or service.

Health & Safety

Safety Precautions

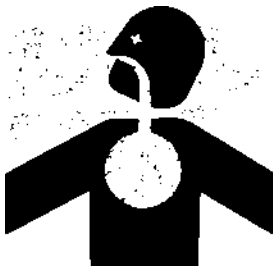

Warning-Ventilation

- Never operate any gas powered mixer in a poorly ventilated or enclosed area.
- Avoid prolonged breathing of exhaust gases.
- Engine exhaust fumes can cause sickness or death.



Warning-Extension Cords

- Always use the proper size grounded extension cord, conforming to the National Electric Code and Local Ordinances.
- Inspect all extension and extension and electrical cords for cuts, frayed wire and broken connectors before use. Do not use cords if not in good condition.
- Do not route extension cords through standing water.
- Do not operate the mixer in standing water.
- When cleaning the mixer, never spray water over the motor.



Wear Protective Clothing

- Wear close fitting clothing and safety equipment appropriate to the job.
- Prolonged exposure to loud noise can cause impairment or loss of hearing.
- Wear a suitable hearing protective device such as earmuffs or earplugs to protect against objectionable or uncomfortable loud noises.
- Operating equipment safely requires the full attention of the operator. Do not wear radio or music headphones while operating machine.

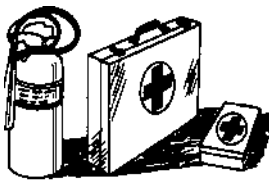

Prepare for Emergencies

- Be prepared if a fire starts.
- Keep a first aid kit and fire extinguisher handy.
- Keep emergency numbers for doctors, ambulance service, hospital, and fire department near your telephone.



Warning-Eye Protection

- Always wear splash goggles when operating mixer.

Health & Safety

Safety Precautions

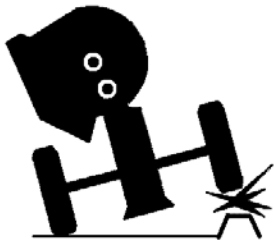

Warning-Towing

- Warning: Do not tow the mixer with the drum in the dump position. Mixer may become unstable and tip over when hitting a curb, pothole, or other obstruction.
- Warning: Always properly attach safety chains before mixer is towed. Maximum towing speed 55 m.p.h. (90 km/hr). Reduce speed according to highway conditions.



Warning-Starting Fluid

- Starting fluid (ether) is highly flammable, do not use or an explosion or fire may result.



Practice Safe Maintenance

- Understand service procedure before doing work. Keep area clean and dry.
- Never lubricate, service or adjust machine while it is moving. Keep hands, feet, and clothing from power-driven parts. Disengage all power and operate controls to relieve pressure. Lower equipment to the ground. Stop the engine. Remove the key. Allow machine to cool.
- Securely support any machine elements that must be raised for service work.
- Keep all parts in good condition and properly installed. Fix damage immediately. Replace worn or broken parts. Remove any buildup of grease, oil, or debris.
- Disconnect battery ground cable (-) before making adjustments on electrical systems or welding on machine.

Dispose of Waste Properly

- Improperly disposing of waste can threaten the environment and ecology. Potentially harmful waste used with equipment includes such items as oil, fuel, coolant, brake fluid, filters, and batteries.
- Use leakproof containers when draining fluids. Do not use food or beverage containers that may mislead someone into drinking from them.
- Do not pour waste onto the ground, down a drain, or into any water source.
- Air conditioning refrigerants escaping into the air can damage the Earth's atmosphere. Government regulations may require a certified air conditioning service center to recover and recycle used air conditioning refrigerants.
- Inquire about the proper way to recycle or dispose of waste from your local environmental or recycling center.

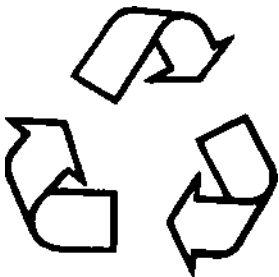



IMPORTANT

The person attempting *any* of the following maintenance tasks must be authorized to do so and have read *and* understood *all* sections within this manual.

Maintenance

Hardware/Fuel/Location and Use of Controls



BEFORE WORKING ON MACHINE, MAKE SURE ENGINE SPARK PLUG WIRE IS DISCONNECTED, OR, IF ELECTRIC, THAT THE ELECTRIC CORD IS DISCONNECTED, TO PREVENT ANY ACCIDENTAL STARTING.

Hardware--Check all hardware on mixer and engine/motor before starting. Consult the **TORQUE CHART** section of this manual and tighten any loose hardware accordingly.

Fuel--If your mixer is equipped with a gasoline engine, fill the gas tank with clean gasoline from a safety can. Consult the **ENGINE MANUAL** supplied with this unit for the proper type of gasoline required.

DO NOT mix oil with gasoline.

Before operating this unit, it is important to familiarize yourself, and any other personnel who will be using it, with the location and proper use of the controls to insure safe and efficient operation.

A. Always make sure that the drum latch is in the lock position (down) before starting machine. With engine running, turn clutch lever to the right to turn paddles or to the left to stop.

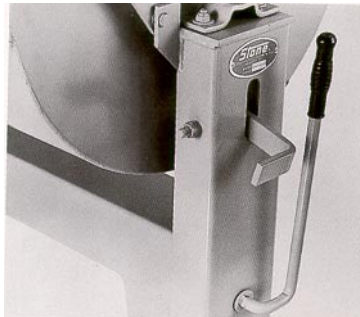

B. To dump mix from drum, stop paddles, move drum latch up and pull dump handle down. Always use caution when dumping mix.

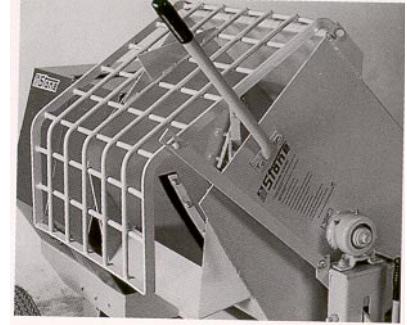

C. Always grease drum seals (both ends as recommended in the maintenance chart. The grease purges dirt--prolonging bearing life.

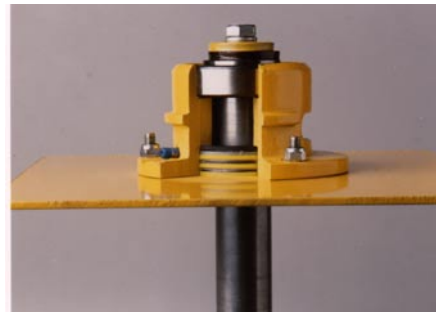

D. Always keep drum and paddles clean. Never run machine with hardened mix or foreign objects in drum--doing so damages paddles and/or engine.

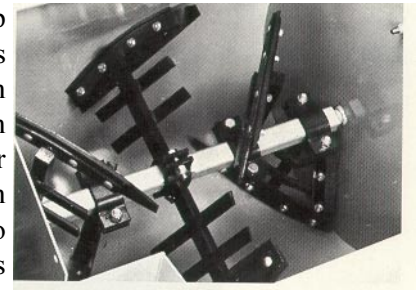

Maintenance

Wheel Bearing Lubrication/Wheel Bearing Adjustment/Hardware

Wheel Bearing Lubrication--Fill wheel hub with grease to inside diameter of outer races and also fill hub grease cap. Never use grease heavier than 265 A.S.T.M. penetration (No. 2 grade). Grease bearing cone by machine or by hand method. Force grease between rollers, cone and cage. (If Ball Bearing Hub: force grease between balls.) It is not recommended that a pressure grease fitting be installed on the hub.

Wheel Bearing Adjustment--Tighten the adjusting nut with a 12" wrench, at the same time turn the wheel in both directions, until there is a slight bind to be sure all bearing surfaces are in contact. Then back off adjusting nut 1/6 to 1/4 turn or to the nearest locking hole or sufficiently to allow the wheel to rotate freely within limits of 0.001" to 0.010" end play. Lock nut at this position.

Hardware--Periodically inspect all hardware on the mixer and engine / motor. Loose hardware can contribute to early component failure and poor performance.

NOTE: Some hardware is used to retain parts that have to move freely for correct operation of this unit. These items include the guard lifter and drum guard. The hardware for these items should be snug enough to prevent excessive play, yet loose enough to allow the parts to pivot freely.

Maintenance

Cleaning/Towing

CLEANING

For consistent performance, long life and continued high quality mixing of plaster or mortar, thoroughly clean the mixer inside and out at the end of each day's operation. To prevent lumps of dried plaster from forming and contaminating future batches of plaster or mortar, do not allow built up materials to form on drum guards, around paddles or anywhere inside the drum.

Before cleaning, shut off the engine or motor and disconnect the spark plug wire or electric cord to prevent accidental starting. Spray the mixer with water before the mix dries to remove any accumulations. Dried mix should be scraped out as necessary. **DO NOT** beat on the drum with a shovel, hammer or other device to break up accumulations of dried mix, as this will dent and damage the drum.



NEVER POUR OR SPRAY WATER OVER THE ENGINE OR MOTOR



NEVER PUT HANDS OR ANY OBJECT INTO THE DRUM WHILE THE ENGINE OR MOTOR IS RUNNING



ALWAYS DISCONNECT THE SPARK PLUG WIRE OR ELECTRIC CORD WHEN CLEANING INSIDE DRUM



ALWAYS MAKE SURE GUARD LIFTER IS RECONNECTED TO GUARD BEFORE USING MIXER--DO NOT OPERATE THE MIXER WITH DRUM GUARD OPEN OR REMOVED

TOWING

Before attempting to tow this mixer, check the state and local laws that apply to your intended route and check the following:

1. Hitch attached to the towing vehicle securely.
2. Towpole fully extended and bolted to mixer securely.
3. Safety chain hooked up properly (see illustration below or decal on mixer front post).

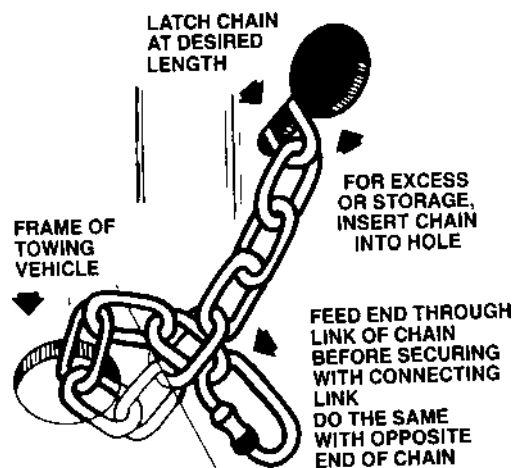

4. Drum in the mixing position and drum latch engaged, clutch lever in the UP position.
5. Lug nuts and axle mount nuts tight.

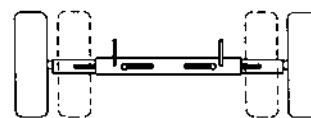

6. On extendible axles, axle extended to full width and adjustment bolts tight.
7. On spring axles - spring mounting hardware tight, main springs and snubber springs not cracked or broken.

8. Tires in good shape and at proper inflation, for maximum safety and load capacity tires should be inflated to the following pressures:

Tire size 4.80 x 12 @ 60 P.S.I.

Tire size 6.50 x 13 @ 35 P.S.I.



DO NOT EXCEED A TOWING SPEED OF 55 MILES/HR (90 KM/HR)



FOR POOR ROAD CONDITIONS OR INCLEMENT WEATHER, REDUCE SPEED ACCORDINGLY

Refer to FRAME AND DRUM ASSEMBLY, STANDARD AXLE ASSEMBLY and SPRING AXLE ASSEMBLY sections of this manual for parts identification and location.

Maintenance

Bearing and Seal Installation

**Instructions for Seal & Bearing Assembly Kits
P/N 23432
STONE® Mortar Mixers
1050PM, 1265PM, 1285PM, 1650PM and HM1290**

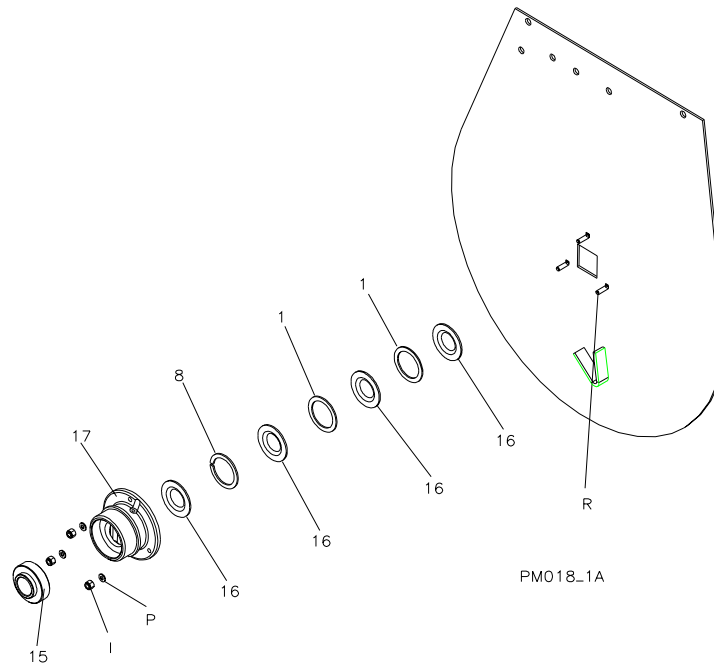

ITEM	P/N	DESCRIPTION	QUANTITY
1	24017	Washer	2
8	25881	Washer Split	1
15	32003	Bearing	1
16	32324	Seal Drum Yellow	4

1. Disassemble drum from frame and remove. Unscrew end bolts from paddle shaft and remove spacers and bull gear.
2. Attach a three-jaw puller to ring on housing, center puller on paddle shaft and remove housing and bearing.
3. Remove worn components and clean shaft and housing as needed.
4. Assemble seals and spacers over paddle shaft, flush with drum end using soapy water mixture as lubricant.
5. Make sure seals are assembled tight up to drum end; inner lip of seals curve inwards towards drum end as illustrated.
6. Insert bearing into housing and slide over shaft and seals as illustrated.
7. Tighten housing evenly to drum end so as not to pinch seals.
8. Reassemble spacer, bull gear (if applicable), washer and bolt to paddle shaft and repeat steps 4-7 on opposite end and reassemble drum to frame.

BULL GEAR ASSEMBLY

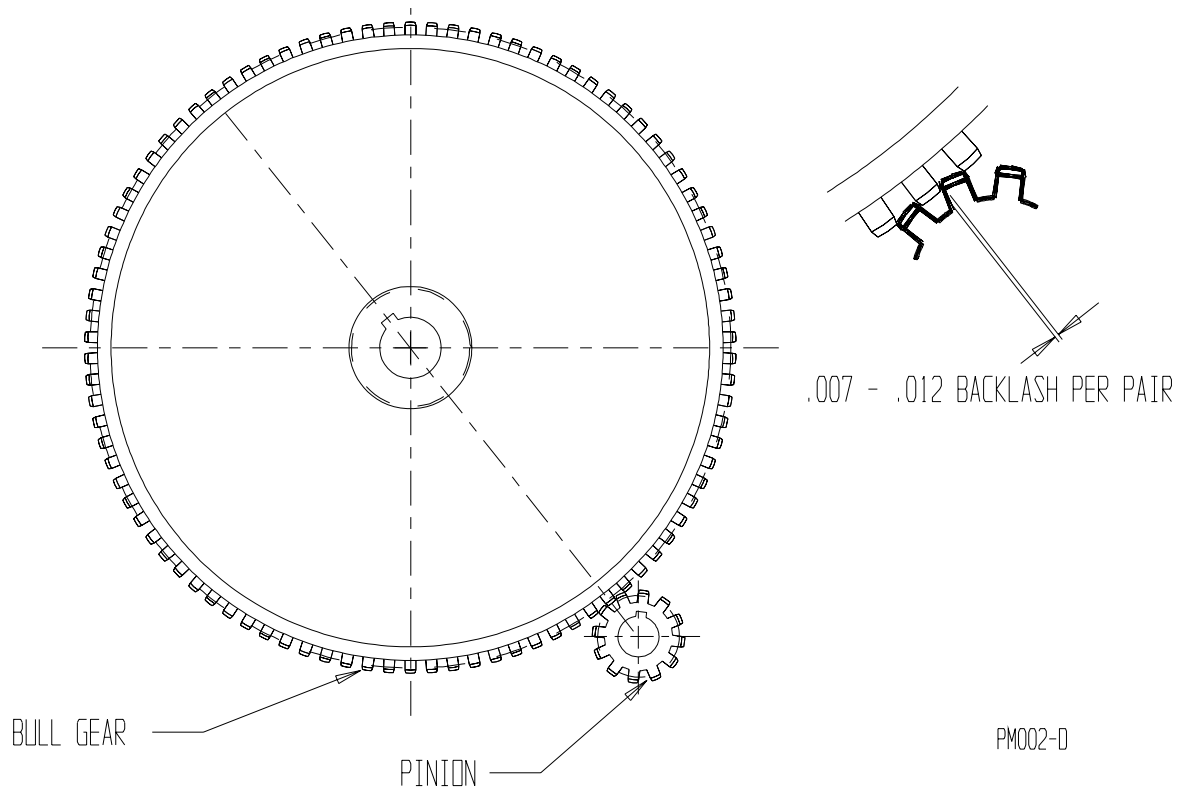

1. Align Bull Gear keyway opposite to gear mesh.
2. Adjust pinion for tooth alignment and engagement using .010" feeler gauge.
3. Tighten all four (4) pillow block bolts before removing feeler gauge.

Maintenance

**1050PM, 1265PM,
1285PM, 1650PM**

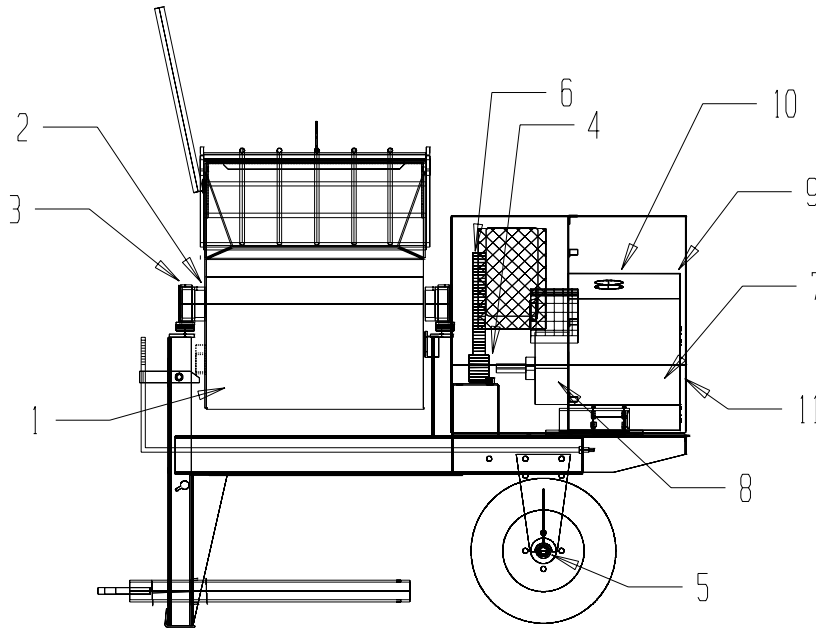

MIXER MAINTENANCE REFER TO MIXER OWNER'S MANUAL PROVIDED PRIOR TO OPERATING OR SERVICING EQUIPMENT	EVERY 5 HOURS OR DAILY	25 HOURS OR EVERY WEEK	50 HOURS OR EVERY MONTH	100 HOURS OR EVERY YEAR
1. MIXER: CLEAN MIXER INSIDE & OUT/REMOVE ALL BUILD UP	CLEAN			
2. DRUM SEALS: GREASE FITTINGS W/ LITHIUM BASE GREASE		GREASE		
3. TRUNNIONS: GREASE FITTINGS W/ LITHIUM BASE GREASE		GREASE		
4. PILLOW BLOCK BEARINGS: W/ LITHIUM BASE GREASE		GREASE		
5. WHEEL HUBS: REPACK EVERY YEAR W/ WHEEL BRG GREASE				EVERY YEAR
6. BULL GEAR: LIGHTLY GREASE EVERY 250 HRS				
ENGINE MAINTENANCE				
REFER TO ENGINE OWNER'S MANUAL PROVIDED PRIOR TO OPERATING OR SERVICING EQUIPMENT				
7. OIL LEVEL: 40F-110F SAE 30W SE,SF,SG	CHECK		CHANGE *	
BELOW 40F SAE 10W-30 SE,SF,SG	CHECK		CHANGE *	
8. REDUCTION OIL: SAE 30W SE,SF,SG				CHANGE
9. AIR FILTER: PRE-CLEANER WASH IN SOAP & WATER/APPLY OIL		CLEAN **		REPLACE
ELEMENT CLEAN BY TAPPING		CLEAN **		REPLACE
10. SPARK PLUG: CLEAN OR REPLACE			CLEAN	REPLACE
11. COOLING SYS & AIR SCREEN				CLEAN

* CHANGE OIL AFTER FIRST 5 HOURS, THEN EVERY 50 HOURS
CHANGE OIL EVERY 25 HOURS UNDER HEAVY LOADS OR HIGH TEMPERATURES
** CLEAN/CHANGE AIR FILTER MORE OFTEN UNDER DUSTY CONDITIONS

SAFETY 1ST DISCONNECT SPARK PLUG OR ELECTRIC CORD BEFORE SERVICING
DANGER DO NOT REFUEL WHEN ENGINE IS HOT OR SMOKE WHEN REFUELING
AVOID PROLONGED BREATHING OF EXHAUST GASES PM004-A

Maintenance

Gearcase Clutch Adjustment

If the clutch begins to slip, it must be readjusted to prevent it from becoming overheated and damaged. For optimum performance, it is necessary to have between 35-55 lbs. pressure on the clutch lever when engaging the paddles. After the first 25 hours of operation, this pressure (35-55 lbs.) should be checked to assure proper engagement. It may be necessary to check periodically after that if the clutch slip. Refer to the GEARCASE ASSEMBLY drawing for parts identification and proceed as follows:

CAUTION: ALWAYS DISCONNECT SPARK PLUG WIRE(S) OR ELECTRIC CORD BEFORE ATTEMPTING TO ADJUST THE CLUTCH.

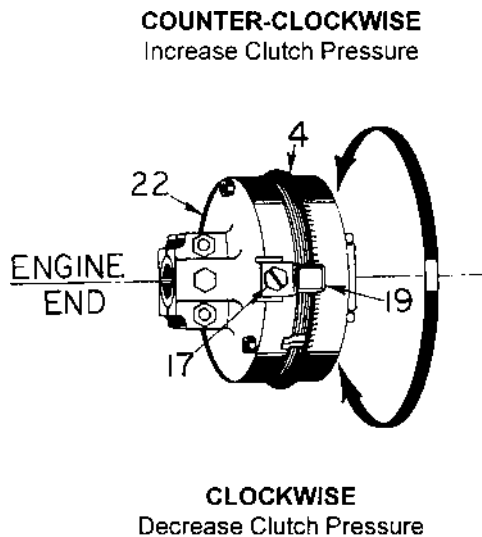

clutchadj.tif

1. On gasoline powered models, stop engine and disconnect spark plug wire(s). On electric powered models, turn off motor and disconnect electric cord.
 2. drain the oil from the gearcase by removing the magnetic drain plug from the clutch access cover.
 3. After draining the oil, remove the (4) 5/16 hex head bolts from the access cover. Remove the cover and gasket.
 4. Make sure the clutch is disengaged by pulling the clutch lever towards the rear of the mixer.
 5. Refer to the clutch drawing. Rotate the clutch until the adjustment lock bolt and adjustment lock are visible.
- NOTE** - on gas powered models it is easier to use the recoil starter to rotate the clutch. **MAKE SURE THE SPARK PLUG WIRE(S) ARE DISCONNECTED--DO NOT START THE ENGINE.**
6. Loosen the adjustment lock bolt just enough to release the adjustment lock and rotate the adjustment lock towards the engine to get it clear.
 7. Keep the clutch housing from turning and rotate the adjusting ring one notch at a time in a counterclockwise direction until a very firm pressure is felt when engaging the clutch with the lever, as the clutch snaps into engaged position.
 8. When the clutch is adjusted satisfactorily, reposition the adjustment lock bolt. Reinstall the clutch access cover and access cover gasket (make sure the gasket isn't broken and that it fits properly) with (4) 5/16 hex head bolts and lock washers. Install the magnetic drain plug into the access cover and tighten the plug and access cover bolts securely.
 9. Remove the oil fill plug from the upper right side of the gearcase and refill the gearcase with 2 - 1/4 quarts of SAE 90 motor oil. Replace the oil fill plug and tighten securely.
 10. Reconnect spark plug wire(s) or electric cord, start engine / motor and run the mixer for a couple of minutes. Shut off allow oil level to settle and check for leaks. Double check oil level, it should be halfway across oil sight glass plug in clutch access cover.

Exploded Diagram and Parts List

EXPLODED DIAGRAM AND PARTS LIST	25-71
Frame and Drum Assembly - 1050PM.....	26-29
Frame and Drum Assembly - 1265PM, 1285PM, 1650PM	30-33
Paddle Assembly - 1050PM	34-35
Paddle Assembly - 1265PM and 1285PM	36-37
Paddle Assembly - 1650PM	38-39
Electric Motor Drive Train - 1050PM	40-43
Electric Motor Drive Train - 1265PM	44-45
Gas Engine Drive Train 1050PM/1265PM	46-49
Clutch Assembly - 1050PM	50-51
Clutch Assembly - 1265PM	52-53
Gearcase Assembly - 1285PM and 1650PM.....	54-59
Clutch Assembly - 1285PM, 1650PM	60-61
Spring Axle Assembly	62-63
Trailer Lights Assembly Option	64-65
Exhaust Systems	66-67
Electric Wiring	68-69
Decal Identification	70-71

Parts List

Frame and Drum Assembly - 1050PM

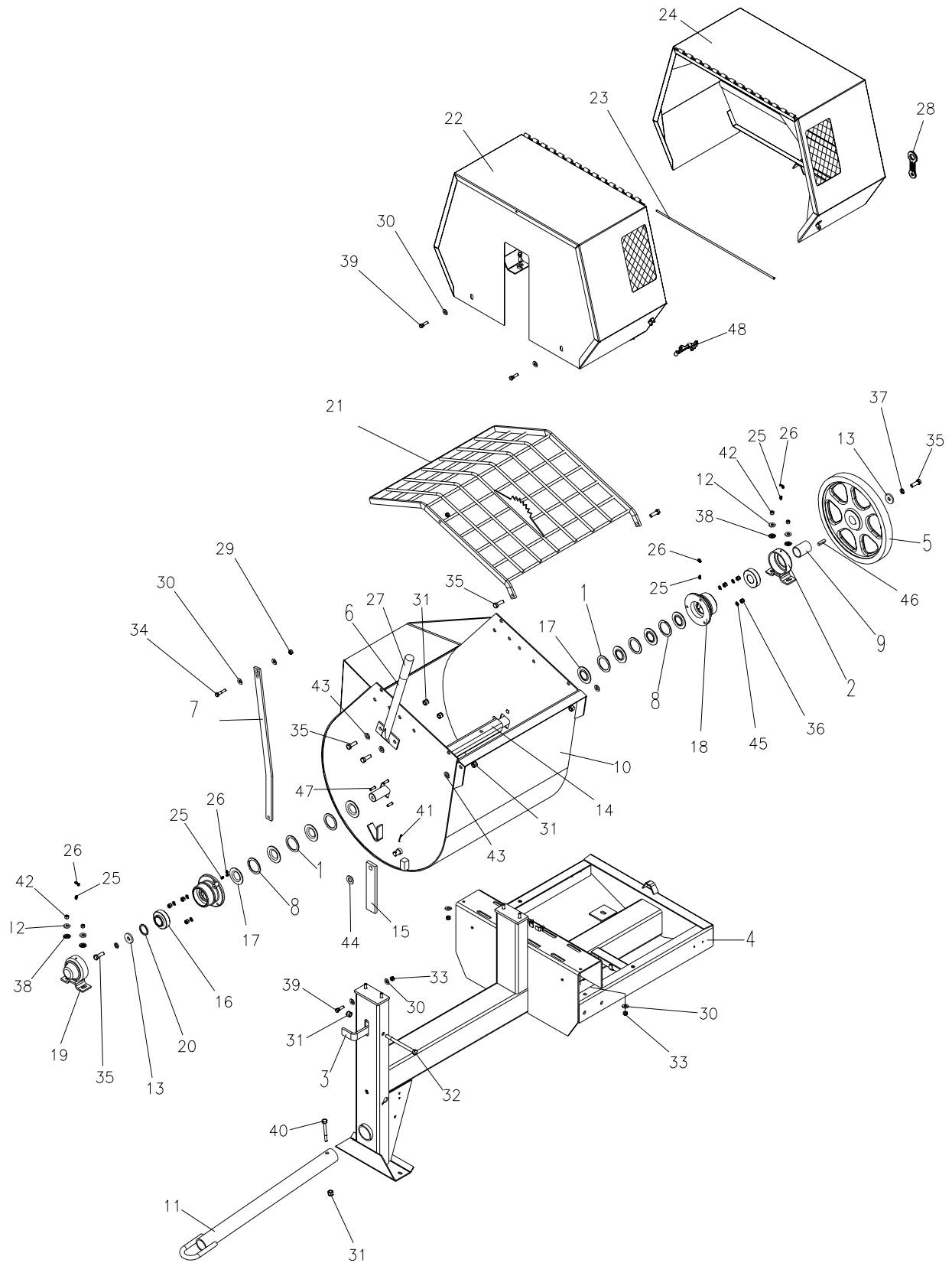

Parts List

Frame and Drum Assembly -1050PM

Item	Part No.	Description	Qty.
1	24017	Seal Spacer	4
2	24021-2	Trunnion EE	1
3	24027-2	Latch Drum	1
4	24258-2	Frame 1050PM	1
5	24329	Bull Gear	1
6	24763-2	Dump Handle	1
7	24920-2	Lifter Guard	1
8	25881	Washer Split	2
9	25928	Spacer Shaft EE	1
10	25951-2	Drum 1050PM	1
11	26096-2	Tow Pole	1
12	26325	WSHR .375 ID x 1.00 OD x .187 ZN	
13	26326	WSHR 9/16 x 1-3/4 x 1/4	2
14	22340	Kit Paddle Shaft 1050PM	1
15	28372-2	Stop Back Drum	1
16	32003	Bearing	2
17	32324	Drum Seal Yellow	8
18	32326	Housing Bearing Machined	2
19	36574	Weld Trunnion Capped TPE	1
20	44284	Spacer Shaft TPE	1
21	44363-2	Guard 1050PM	1
22	44371-2	Cowl Assy Stry	1
23	44372	Pin Hinge	1
24	44380-2	Cowl Assy Mvbl	1
25	46042	Fitting Grease 1/4-28 ZN	4
26	47001	Caplug Blue	4
27	47023	Grip Hand	1
28	47182	Latch Rubber	1
29	80042	NUTFX 3/8-16 ZN	1
30	80043	WSHR 3/8 WROT ZN	20
31	80051	NUTNY 1/2-13 ZN	6
32	80052	HHCS 1/2-13 x 6-1/2 ZN	1
33	80056	NUTNY 3/8-16 ZN	8
34	80178	HHCS 3/8-16 x 2 GR 5 ZN	1

Parts List

Frame and Drum Assembly - 1050PM

Item	Part No.	Description	Qty.
35	80075	HHCS 1/2-13 X 1-1/2 ZN	6
36	80114	NUTNY 5/16-18 ZN	6
37	80117	WSHRL 1/2 Med Split ZN	2
38	80119	WSHRLT 3/8 ZN	4
39	80145	HHCS 3/8-16 x 1-1/4 ZN	7
40	80197	HHCS 1/2-13 x 4 ZN	1
41	80316	PINCT 1/8 x 1-1/2 ZN	1
42	80326	NUTFL 3/8-16 1/2 Height ZN	4
43	80343	WSHR 1/2 SAE ZN	4
44	80344	WSHR 3/4 SAE ZN	1
45	80495	WSHR SAE 5/16 ZN	6
46	81060	Key Square 3/8 x 1-1/2	1
47	81064	CRBLT 5/16-18 x 1.25	6
48	35289	Latch Flex Draw	2
49^	21655	Kit Safety Chain	1
50^	22130-2	Tow Pole Pin Hitch (optional)	1
51^	22194-2	Tow Pole Ball Hitch (optional)	1
52^	23222	Kit Cowl Full (includes 22,23,24 and Decals)	1
53^	23224	Kit Cowl Mvbl (includes 23,24 and Decals)	1
54^	23432	Kit Bearing Seal Spacer LgPM (includes 1, 8, 16, 17)	1

Parts List

Frame and Drum Assembly - 1265PM/1285/1650PM

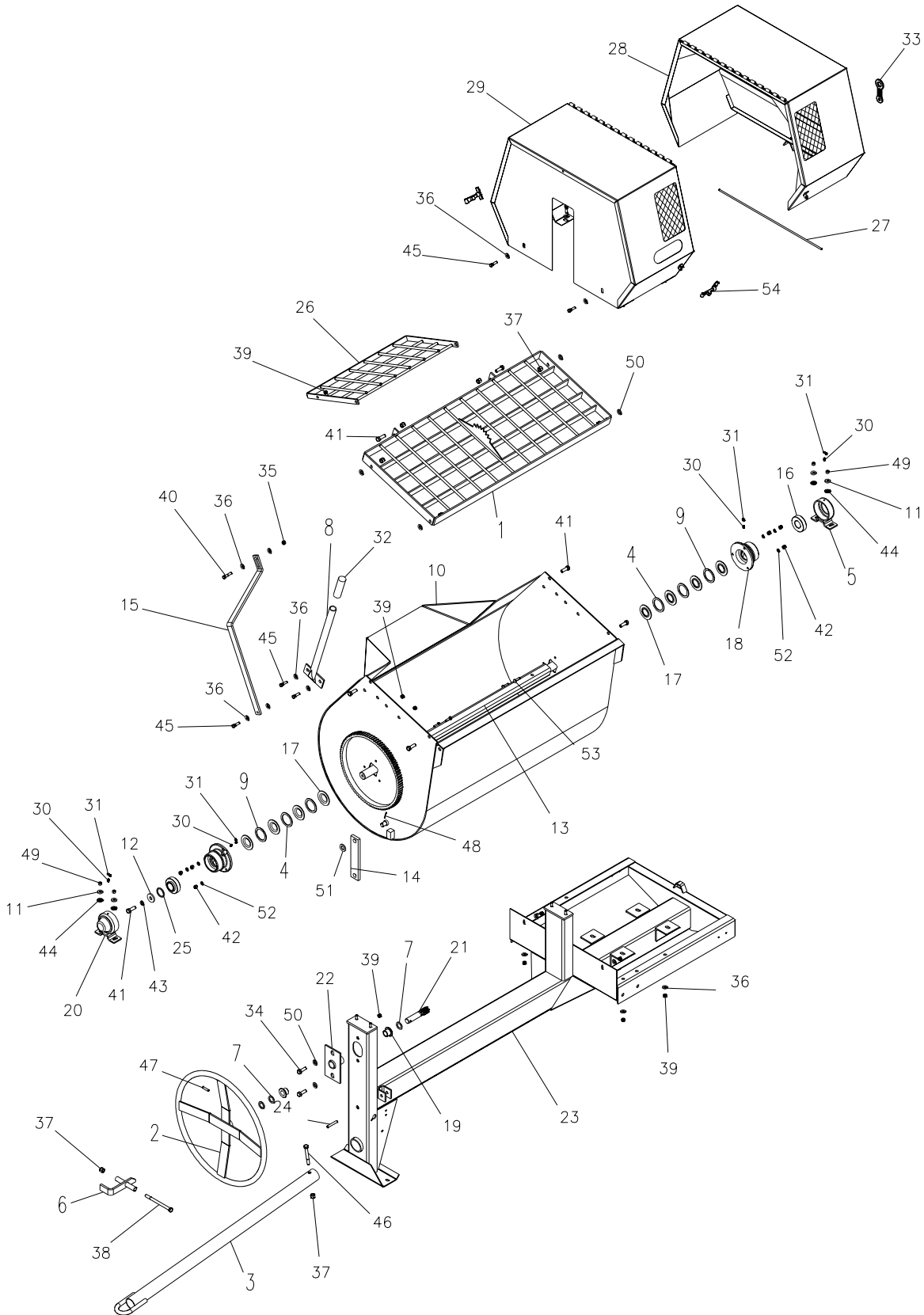

Parts List

Frame and Drum Assembly - 1265PM/1285/1650PM

Item	Part No.	Description	Qty.
1	22023-2	Guard Stationary (1265PM/1285PM)	1
1b	22021-2	Guard Stationary (1650PM)	1
2	22096-2	Handwheel (1650PM)	1
3	22097-2	Tow Pole Standard 47 Inch	1
4	24017	Spacer Seal	4
5	24021-2	Trunnion EE	1
6	24027-2	Latch Drum (1265PM/1285PM)	1
7	24622	WSHR 1-1/32 x 1-1/2 x 1/8 (1650PM)	3
8	24763-2	Dump Handle (1265PM/1285PM)	1
9	25881	WSHR Split	2
10	25911-2	Drum (1265PM/1285PM)	1
10b	25895-2	Drum (1650PM)	1
11	26325	WSHR .375 ID x 1.00 OD x .187 ZN	4
12	26326	WSHR 9/16 x 1-3/4 x 1/4	1
13	22342	Kit Paddle Shaft (1265PM)	1
13b	22345	Kit Paddle Shaft (1285PM)	1
13c	22348	Kit Paddle Shaft (1650PM)	1
14	28372-2	Stop Back Dump (1265/1285PM)	
14b	28151-2	Stop Back Dump (1650PM)	1
15	28149-2	Lifter Guard (1265PM, 1285PM)	1
15b	28201-2	Lifter Guard (1650PM)	1
16	32003	Bearing	2
17	32324	Seal Drum Yellow	8
18	32326	Housing Bearing	2
19	35297	Bearing Oil Lite 1650PM	2
20	36574-2	Trunnion Capped	1
21	42618	Assy Tilt Shaft 6T 1650PM	1
22	42616-2	Tilt Plate (1650PM)	1
23	22218-2	Frame 1265PM/1285PM	1
23b	42679-2	Frame 1650PM	1
24	44099	Snapper Pin ZN (1650PM)	1
25	44284	Spacer Drum Shaft TPE	1
26	44365-2	Guard Moveable	1
27	44372	Pin Hinge	1
28	44380-2	Cowl Assy Moveable	1

Parts List

Frame and Drum Assembly - 1265PM, 1285PM, 1650PM

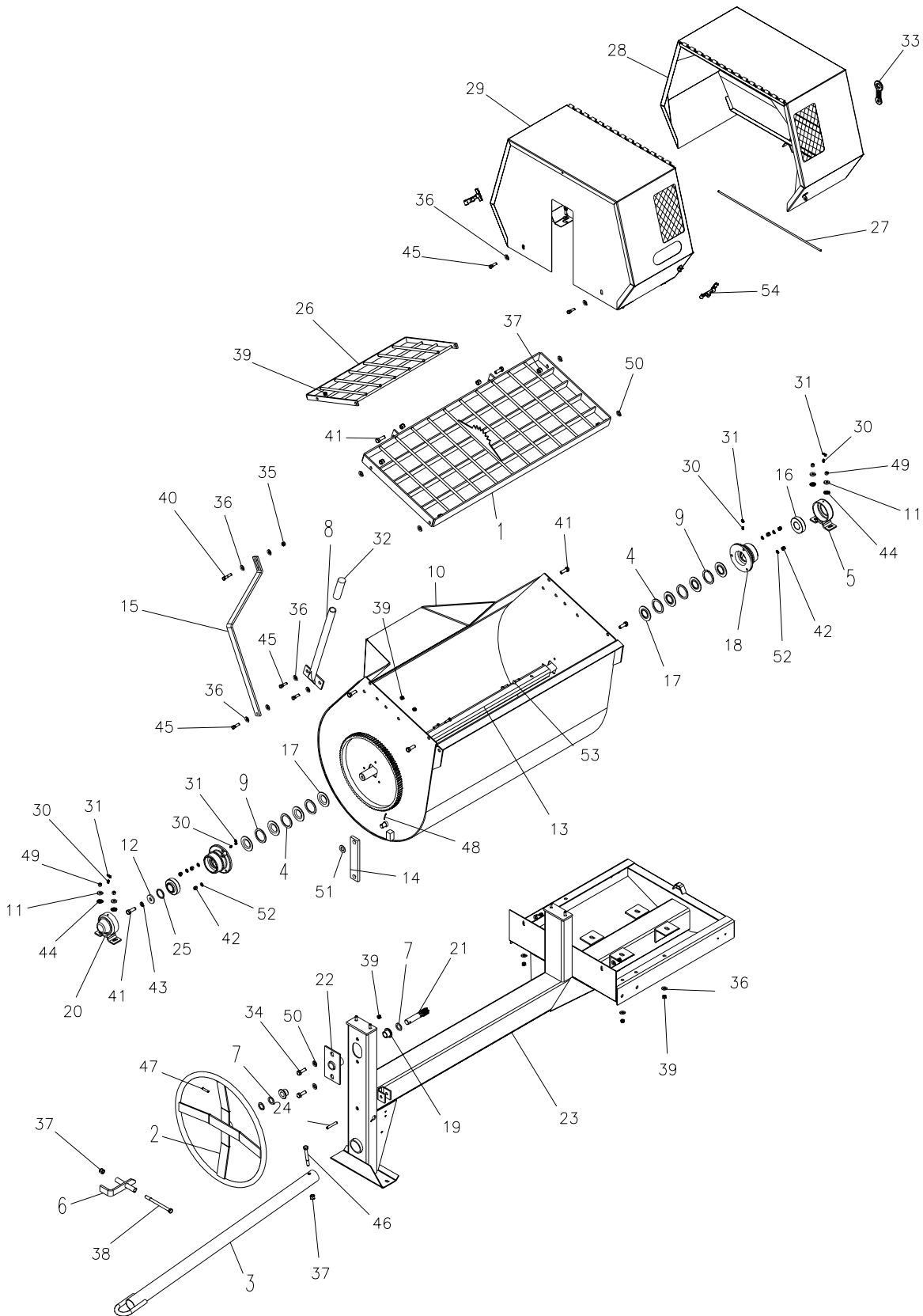

Parts List

Frame and Drum Assembly - 1265PM/1285/1650PM

Item	Part No.	Description	Qty.
29	44371-2	Cowl Assy Stationary (1265PM)	1
29b	44381-2	Cowl Assy Stationary (1285PM/1650PM)	1
30	46042	Fitting Grease	4
31	47001	Caplug Blue	4
32	47023	Grip Handle (1265PM/1285PM)	1
33	47182	Latch Cowl	1
34	80031	HWHTB 1/2-13 x 1-1/2 (1650PM)	2
35	80042	NUTFX 3/8-16 ZN	1
36	80043	WSHR 3/8 WROT ZN	22
37	80051	NUTNY 1/2 - 13 ZN (1265PM/1285PM)	8
37b	80051	NUTNY 1/2 - 13 ZN (1650PM)	7
38	80052	HHCS 1/2-13 x 6-1/2 ZN (1265PM/1285PM)	1
39	80056	NUTNY 3/8 - 16 ZN	10
40	80072	HHCS 3/8-16x1-3/4 GR5 ZN	1
41	80075	HHCS 1/2 - 13 x 1-1/2 ZN	12
42	80114	NUTNY 5/16-18 ZN	6
43	80117	WSHRL 1/2 Med Split ZN	1
44	80119	WSHRLT 3/8 ZN	4
45	80145	HHCS 3/8-16 x 1 - 1/4 ZN	9
46	80197	HHCS 1/2 - 13 x 4 ZN	1
47	80309	PINSP 5/16 x 1-1/2 (1650PM)	1
48	80316	PINCT 1/8 x 1-1/2 ZN	1
49	80326	NUTFL 3/8 - 16 ZN 1/2 Height	4
50	80343	WSHR SAE 1/2 ZN	6
51	80344	WSHR 3/4 SAE ZN	1
52	80495	WSHR 5/16 SAE ZN	6
53	81064	CRBLT 5/16-18 x 1-1/4 ZN	6
54	35289	Latch Flex Draw	2
55^	22130-2	Tow Pole Hitch (option)	1
56^	22195-2	Tow Pole Ball Hitch (option)	1
57^	47294	Trim Strip (1285PM/1650PM)	1.5 ft
59^	23222	Cowl Kit Full 1265PM (includes items 27,28,29 & Decals)	1
60^	23223	Cowl Kit Full 1285PM (includes 27,28,29b,54 & Decals)	1
61^	23224	Cowl Kit Full 1650PM (includes 27,28,29b,54 & Decals)	1
62^	22126	Kit Safety Chain	1
63^	23432	Kit Bearing Seal LgPM (includes 4,9,16,17)	1

Note: Cowl Kit Moveable includes items 27,28 & Decals - 33 -

^ Not Shown

Parts List

Paddle Assembly - 1050PM

Item	Part No.	Description	Qty.
1	21466-2	Paddle EEC	1
2	21467-2	Paddle EE	1
3	24106	Blade Rubber Long	4
4	24109	Blade Steel Long (option)	4
5	24104-2	Back Bar Long Not required for steel blade option	4
6	24105	Blade Rubber Short	2
7	24108	Blade Steel Short (option)	2
8	24103-2	Bar Backer Short Not required for steel blade option	2
9	26882	Paddle Clamp	2
10	21465-2	Paddle TPEC	1
11	21464-2	Paddle TPE	1

A	80041	CRBLT 3/8 - 16 X 1 - 1/4 ZN	22
B	80042	NUTFX 3/8 - 16 ZN	22
C	80043	WSHR 3/8 Wrot ZN	22
D	80084	HHCS 5/8 - 11 X 2 - 1/2 ZN	6
E	80082	NUTNY 5/8 - 11 ZN	6

Blade and Paddle Sets

1	21019	Set Rubber Blades Includes (4) Item 3 and (2) Item 6	1
2	21024	Set Steel Blades Includes (4) Item 4 and (2) Item 7	1
3	21026	Set Bar Back Includes (4) Item 5 & (2) Item 8 (not with steel blades)	1
4	21189	Paddle Assy (specify steel or rubber) Includes (1) Items 1 and 2, (4) Items 3 and 5, (2) Items 6 and 8, (1) Items 10 and 11, and (22) Items A, B, C.	1
5	22834	Drum and Paddle Assy (complete) Includes Drum, paddles and standard blades	1

Parts List

Paddle Assembly - 1265PM/1285PM

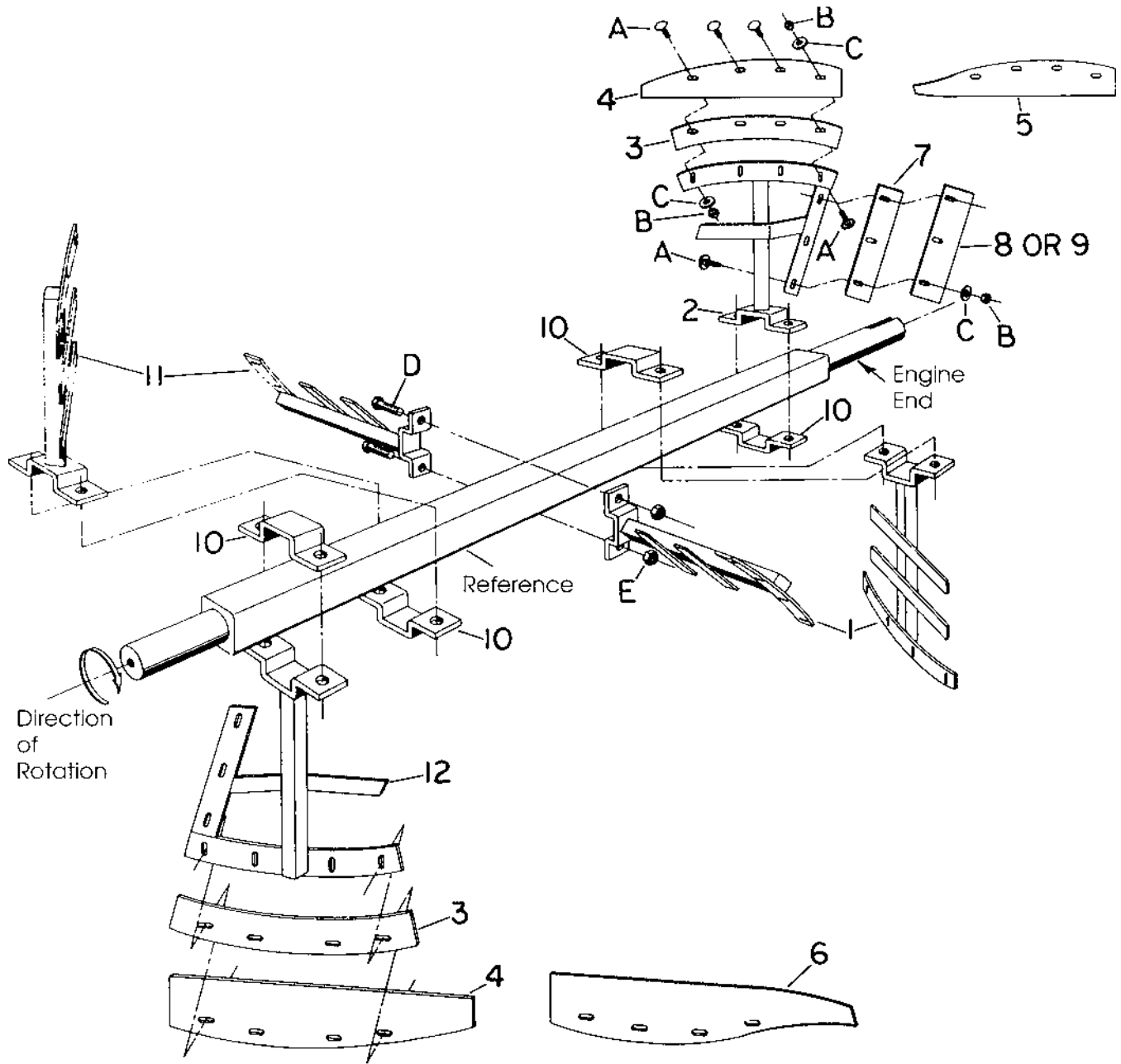

lgpm_pad.tif

Parts List

Paddle Assembly - 1265PM/1285PM

Item	Part No.	Description	Qty.
1	22092-2	Paddle EEC	2
2	22093-2	Paddle EE	1
3	24106	Blade Rubber Long	6
4	28137-2	Back Bar Long	6
5*	28197	Plaster Blade Curved Plated (Not required for steel blade option)	3
6*	28198	Plaster Blade Curved Plated TPE (Not required steel blade option)	3
7	24105	Blade Rubber Short	2
8	24103-2	Back Bar Short	2
9*	28194	PLASTER Blade Curved End	2
10	26882-2	Paddle Clamp	4
11	22091-2	Paddle TPEC	2
12	22090-2	Paddle TPE	1
A	80041	CRBLT 3/8 - 16 X 1 - 1/4 ZN	30
B	80042	NUTFX 3/8 - 16 ZN	30
C	80043	WSHR 3/8 WROT ZN	30
D	80084	HHCS 5/8 - 11 X 2 - 1/2 ZN	10
E	80082	NUTNY 5/8 - 11 ZN	10

Blade and Paddle Sets

1	22127	Set Steel Blades Includes (6) Item 4 and (2) Item 8	1
2	22101	Set Curved Steel Blades Includes (4) Item 6 and (2) Item 9	1
3	22133	Set Rubber Blades Includes (6) Item 3 & (2) Item 7 (not steel blades)	1
4	22098	Paddle Assy (specify steel or rubber) Includes (1) Items 1 and 2, (4) Items 3 and 5, (2) Items 6 and 8, (1) Items 10 and 11, and (22) Items A, B, C.	1
5	22835	Drum and Paddle Assy 1265PM (complete) Includes Drum, paddles and standard blades	1
6	42054	Drum and Paddle Assy 1285PM	1

Parts List

Paddle Assembly -1650PM

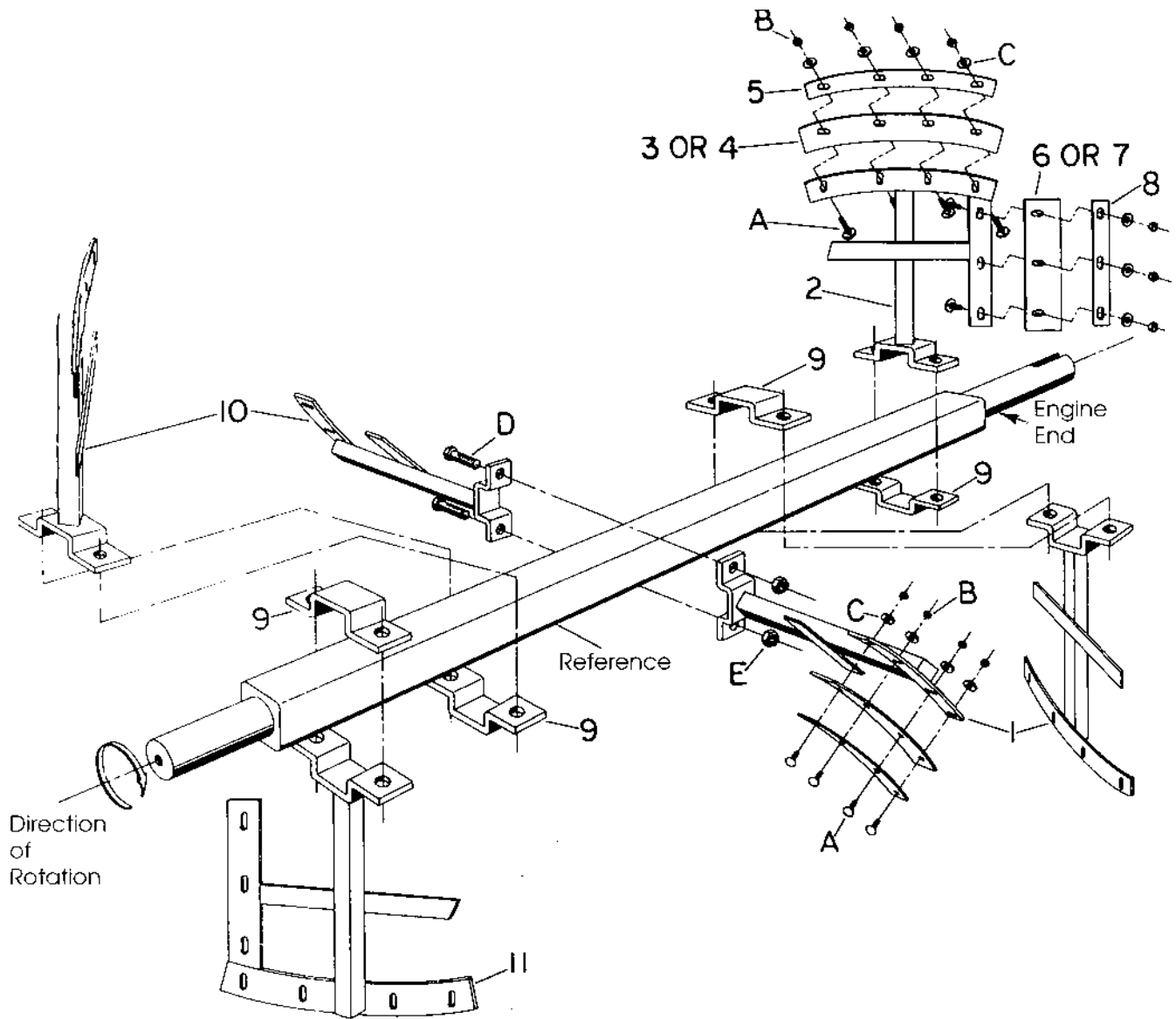

1650_pad.tif

Parts List

Paddle Assembly -1650PM

Item	Part No.	Description	Qty.
1	21466-2	Paddle EEC	2
2	21467-2	Paddle EE	1
3	24106	Blade Rubber	6
4	24109-2	Blade Steel Long (option)	6
5	24104-2	Bar Backer Long (not required for steel blade option)	6
6	24105	Blade Rubber Short	2
7	24108-2	Blade Steel (option)	2
8	24103-2	Bar Backer Short (not required for steel blade option)	2
9	26882-2	Paddle Clamp	4
10	21465	Paddle TPEC	2
11	21464-2	Paddle TPE	1

A	80041	CRBLT 3/8 - 16 X 1 - 1/4 ZN	30
B	80042	NUTFX 3/8 - 16 ZN	30
C	80043	WSHR 3/8 WROT ZN	30
D	80084	HHCS 5/8 - 11 X 2 - 1/2 ZN	10
E	80082	NUTNY 5/8 - 11 ZN	10

Blade and Paddle Sets

1	22133	Set Steel Blades (includes (6) Item 3 and (2) Item 6)	1
2	22134	Set Steel Blades (includes (6) Item 4 and (2) Item 7)	1
3	22135	Set Bar Back (includes 16 of item 5 and 2 of item 8)	
4	22132	Paddle Assy (specify steel or rubber) Includes (2) Item 1, (1) of Item 2, (6) Items 3 and 5, (2) Items 6 and 8, (6) of Item 9, (2) Items 10 and (1) of Item 11 and all hardware	1
5	22836	Drum and Paddle Assy 1650PM (incl drum, paddles & std blades)	1

Parts List

1050PM Electric Motor Drive Train

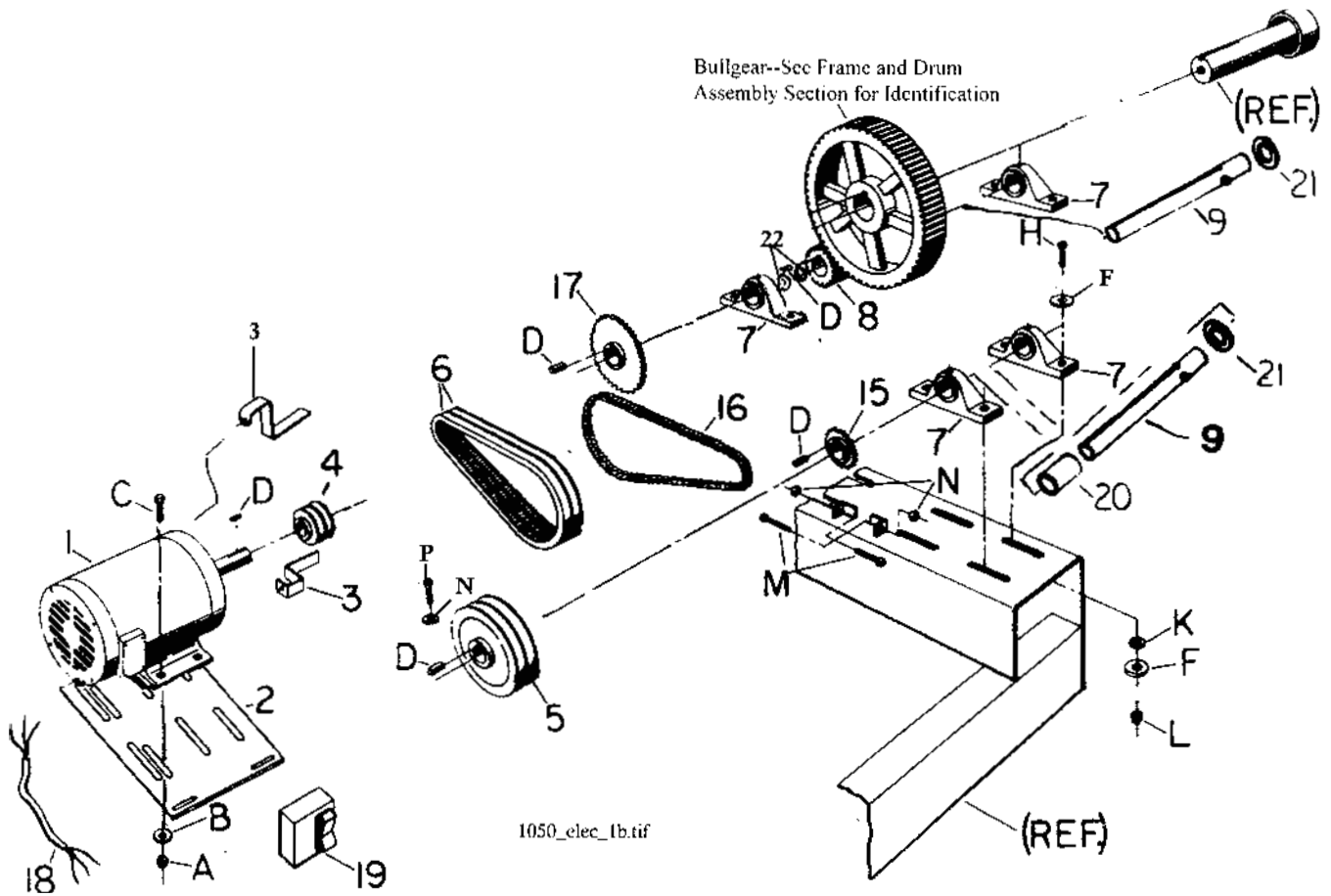

Parts List

1050PM Electric Motor Drive Train

Item	Part No.	Description	Qty.
1	30014	Motor Electric 3HP 1-Phase	1
2	27320-2	Motor Base Electric	1
3	42446-2	Belt Guide	2
4	34776	Sheave 2BK34 x 1-1/8 1-Phase	1
5	34071	Sheave 2BK130 x 1 1-Phase	1
6	34624	V-Belt B45 1-Phase	2
7	32209	Pillow Block	4
8*	23121	Kit Pinion Gear	1
9	22509	Shaft Assembly	2
15	34932	Sprocket H60 18x1	1
16	21185	Chain Assy	1
17	34777	Sprocket 60B 40x1	1
18	36081	Pigtail	1
19	36019	Manual Starter 1-Phase	1
20	42966	Spacer Pinion	1
21	38122	Washer Retainer Pin	2
22	24622	Washer Pinion	2

Parts List

1050PM Electric Motor Drive Train

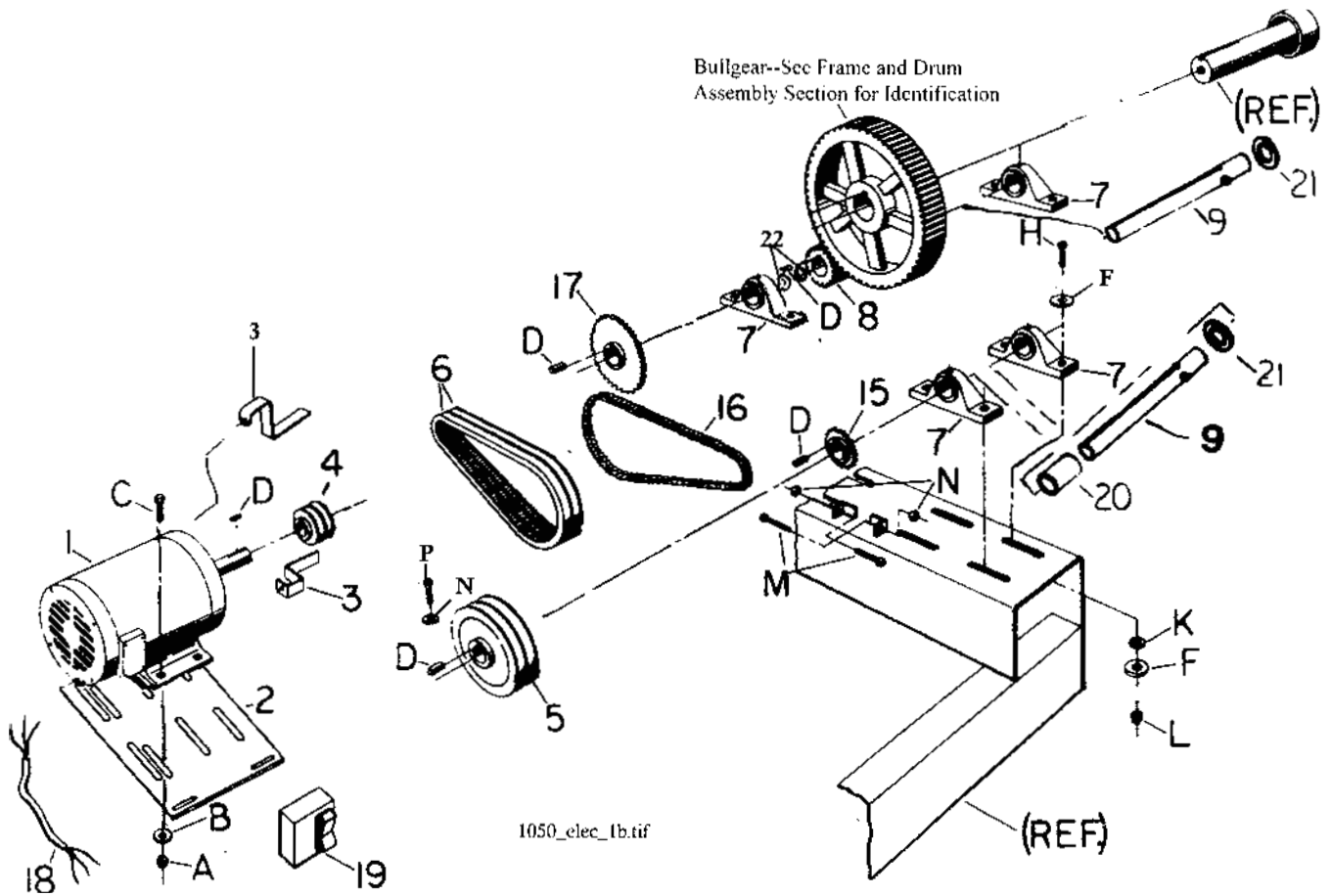

Parts List

1050PM Electric Motor Drive Train

Item	Part No.	Description	Qty.
A	80056	NUTNY 3/8-16 ZN	4
B	26325	WSHR Motor Base	4
C	80145	HHCS 3.8-16 x 1-1/4 ZN	4
D	80100	Key Square 1/4 x 1	4
F	80125	WSHR 17/32 x 1-1/16 x 3/16	16
H	80376	HHCS 7/16-14 x 2-1/4 ZN	8
K	80358	WSHRLT 1/2 INT EXT ZN	8
L	80079	NUTNY 7/16-14 ZN	8
M	80164	HHTB 5/16 x 18 x 1-1/2 ZN	2
N	80244	NUTFXJ 5/16-18 ZN	3
O	80061	Key Square 1/4 x 1-1/2	1
P	80260	SQHSS 5/16-18 x 2 ZN	1

Parts List

1265PM Electric Motor Drive Train

Item	Part No.	Description	Qty.
1	30014	Motor Electric 3HP 1-Phase	1
2	27320-2	Motor Base Electric	1
3	42446-2	Belt Guide	2
4	34517	Sheave 3BK34 X 1 - 1/8	1
5	34522	Sheave 3BK130H X 1	1
6	34624	V-Belt B45	3
7	32209	Pillow Block	4
8	27098	Pinion Gear	1
9	22509	Shaft Assy	2
12	24329-2	Bull Gear	1
13	25928-2	Spacer Gear	1
15	34932	Sprocket 60B180 X 1	1
16	21185	Chain Assy	1
17	34777	Sprocket 60B40 X 1	1
18	36081	Pigtail	1
19	36019	Starter Manual	1
20	29138	Spacer Pinion	1
21	38122	WSHR Retainer Pin	2
22	24622	Washer Pinion	2
A	80056	NUTNY 3/8 - 16 ZN	4
B	26325	WSHR MTR BASE	4
C	80145	HHCS 3/8 - 16 X 1 - 1/4 ZN	4
D	80100	Key Square 1/4 X 1	4
E	81060	KEY 3/8 X 3/8 1 - 1/2	1
F	26326	WSHR 9/16 X 1 - 3/4 X 1/4	1
G	80075	HHCS 1/2 - 13 X 1 - 1/2	1
H	80376	HHCS 7/16 - 14 X 2 - 1/4 ZN	8
J	80125	WSHR 17/32 x 1-1/16 x 3/16	16
K	80358	WSHRLT 1/2 INT EXT ZN	8
L	80079	NUTNY 7/16 - 14 ZN	8
M	80260	SQHSS 5/16 X 18 X 2 ZN	1
N	80244	NUTFXJ 5/16 - 18 ZN	3
O	80061	Key Square 1/4 x 1-1/2	1
P	80164	HHTB 5/16-18 x 1-1/2	2

Parts List

1050PM/1265PM Gas Engine Drive Train

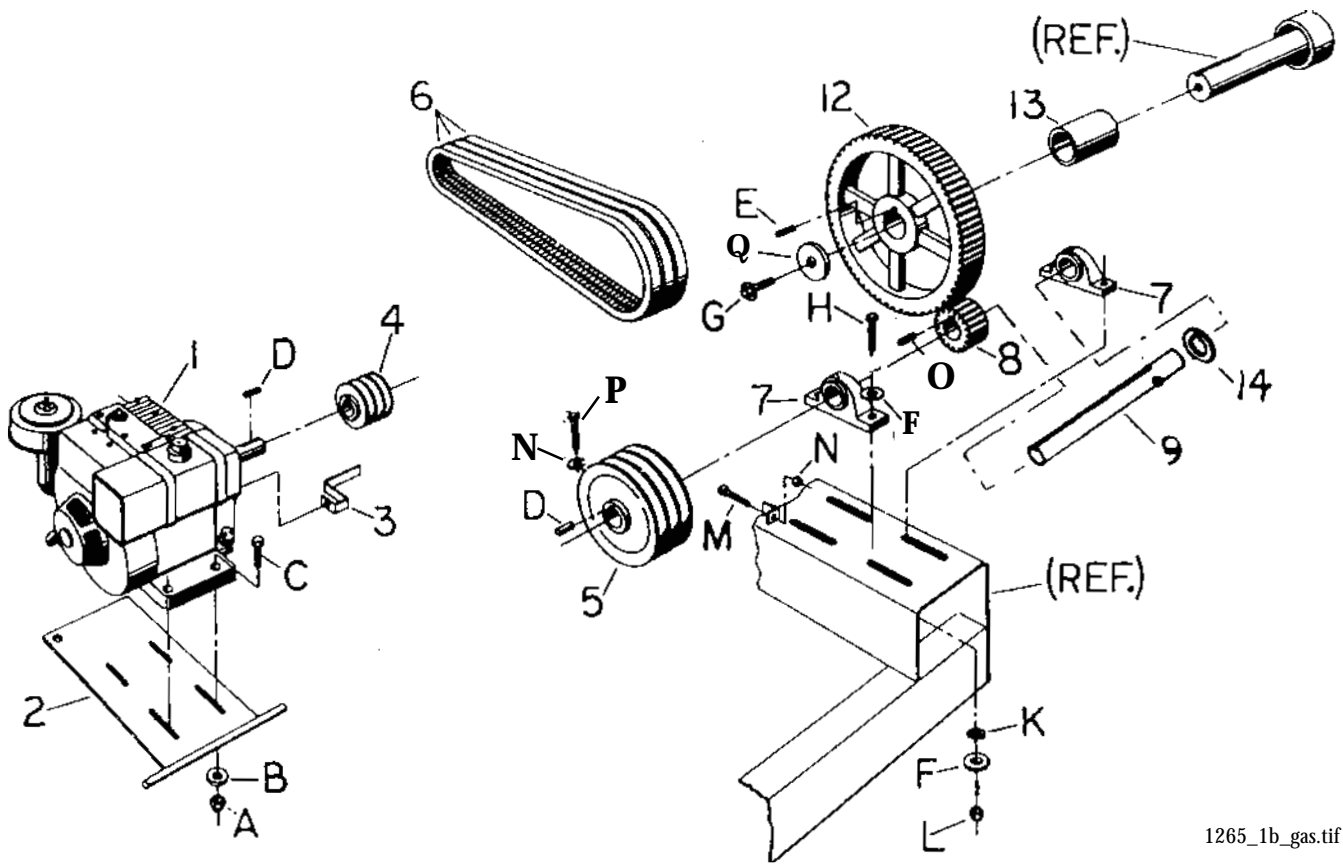

1265_1b_gas.tif

Parts List

1050PM/1265PM Gas Engine Drive Train

Item	Part No.	Description	Qty.
1	30597	Engine 8.5hp Robin (1050PM Only)	1
1b	30398	Engine 8hp B&S (1050PM Only)	1
1c	30399	Engine 8hp B&S I/P (1050PM Only)	1
1d	30155	Engine 8hp Honda (1050PM Only)	1
1e	42999	Engine 10hp B&S I/P (1050PM/1265PM Only)	1
1f	30341	Engine 10hp Honda (1265PM Only)	1
2	22570-2	Motor Base 8.5hp Robin/8hp Honda	1
2b	27404-2	Motor Base 8hp B&S/8hp B&S I/P (11hp Honda/10hp B&S I/P)	1
3	26199-2	Belt Guide (8.5 Robin assembled opposite side as shown)	1
4	34779	Sheave 2BK34 - 1 (1050PM Only)	1
4b	34666	Sheave 3BK34-1 (1265PM Only)	1
5	34517	Sheave 3BK34-1-1/8 (1265PM Only)	1
5b	34775	Sheave 2BK90 - 1 (1050PM Only)	1
5c	34518	Sheave 3BK90-1(1265PM Only)	1
6	34933	V-belt B-37 (1050pm)	2
6b	34933	V-belt B-37 (1265pm)	3
7	32209	Pillow Block	2
8	27098	Pinion Gear	1
9	22509	Shaft Assembly	1
12	24329-2	Bull Gear	1
13	25928-2	Spacer Gear	1
14	38122	Washer Retainer Pin	1
15	24622	Washer Pinion 1-1/32 ID x 1-1/2 OD x 1/8	2

Parts List

1050PM/1265PM Gas Engine Drive Train

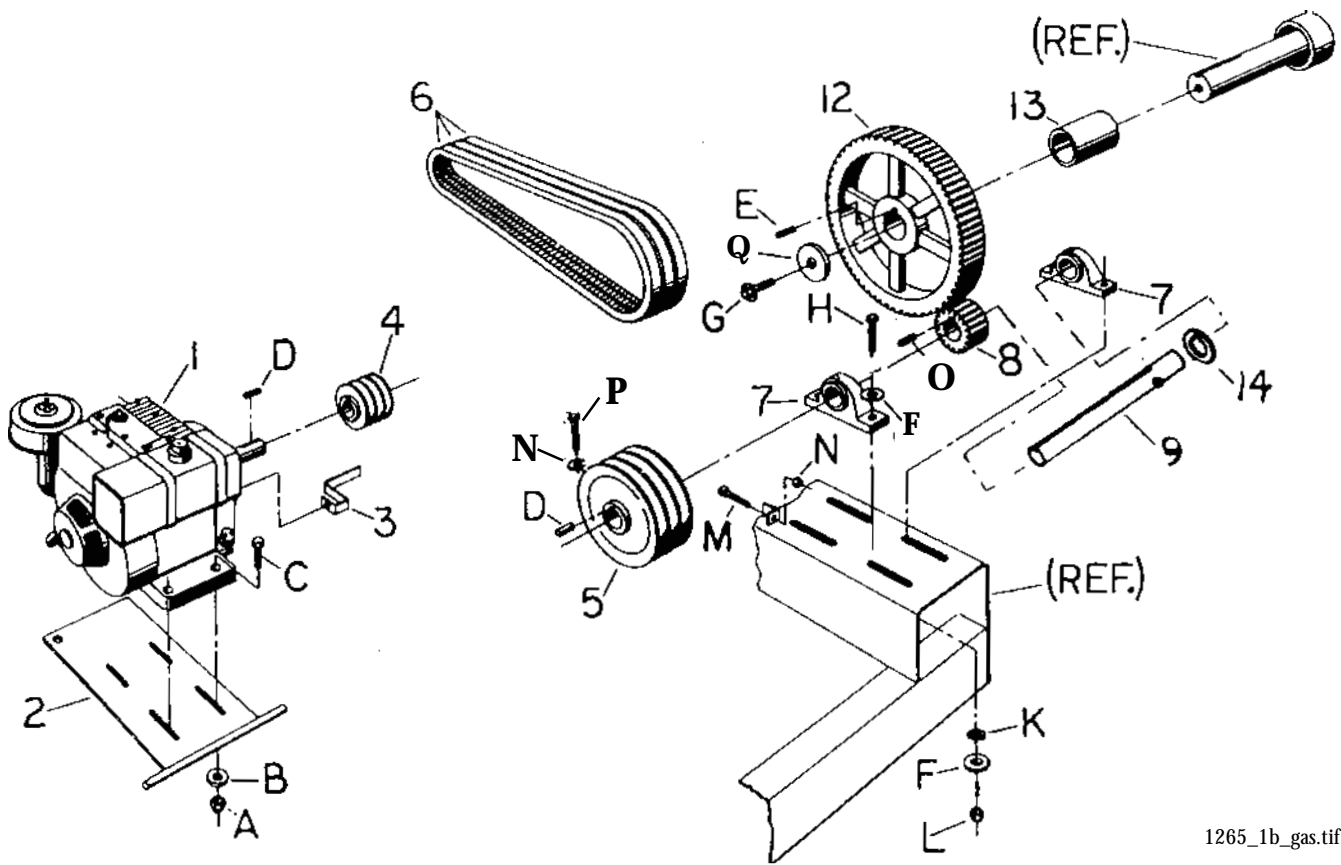

1265_1b_gas.tif

Parts List

1050PM/1265PM Gas Engine Drive Train

Item	Part No.	Description	Qty.
A	80056	NUTNY 3/8 - 16 ZN (8.5R, 8H, 11H)	4
A2	80114	NUTNY 5/16-18 ZN (8B&S, 8B&S I/P, 10B&S I/P)	4
B	26325	WSHR Motor Base .375 ID x 1.0 OD x .187 ZN	4
C	80178	HHCS 3/8-16 x 2 ZN GR5 (8.5 Robin, 8, 11 Honda)	
C2	80169	HHCS 5/16 - 18 x 2 ZN GR5 (8B&S, 8B&S I/P, 11 B&S I/P)	4
D	80100	KEY 1/4 x 1/4 x 1	2
E	81060	KEY 3/8 x 3/8 1 - 1/2	1
F	80125	WSHR 17/32 x 1-1/16 x 3/16	8
G	80075	hhcs 1/2 - 13 x 1 - 1/2	1
H	80392	HHCS 7/16 - 14 x 2 - 1/4 ZN	4
K	80358	WSHRLT 1/2 INT EXT ZN	4
L	80079	NUTNY 7/16 - 14 ZN	4
M	80164	HHTB 5/16 x 18 x 1-1/2 ZN	1
N	80244	NUTFXJ 5/16 - 18 ZN	2
O	80061	Key Square 1/4 x 1-1/2	1
P	80260	SQHSS 5/16-18 x 2 ZN	1
Q	26326	WSHR 9/16 x 1-3/4 x 1/4 Pln	1

Parts List

1050PM Clutch Assembly

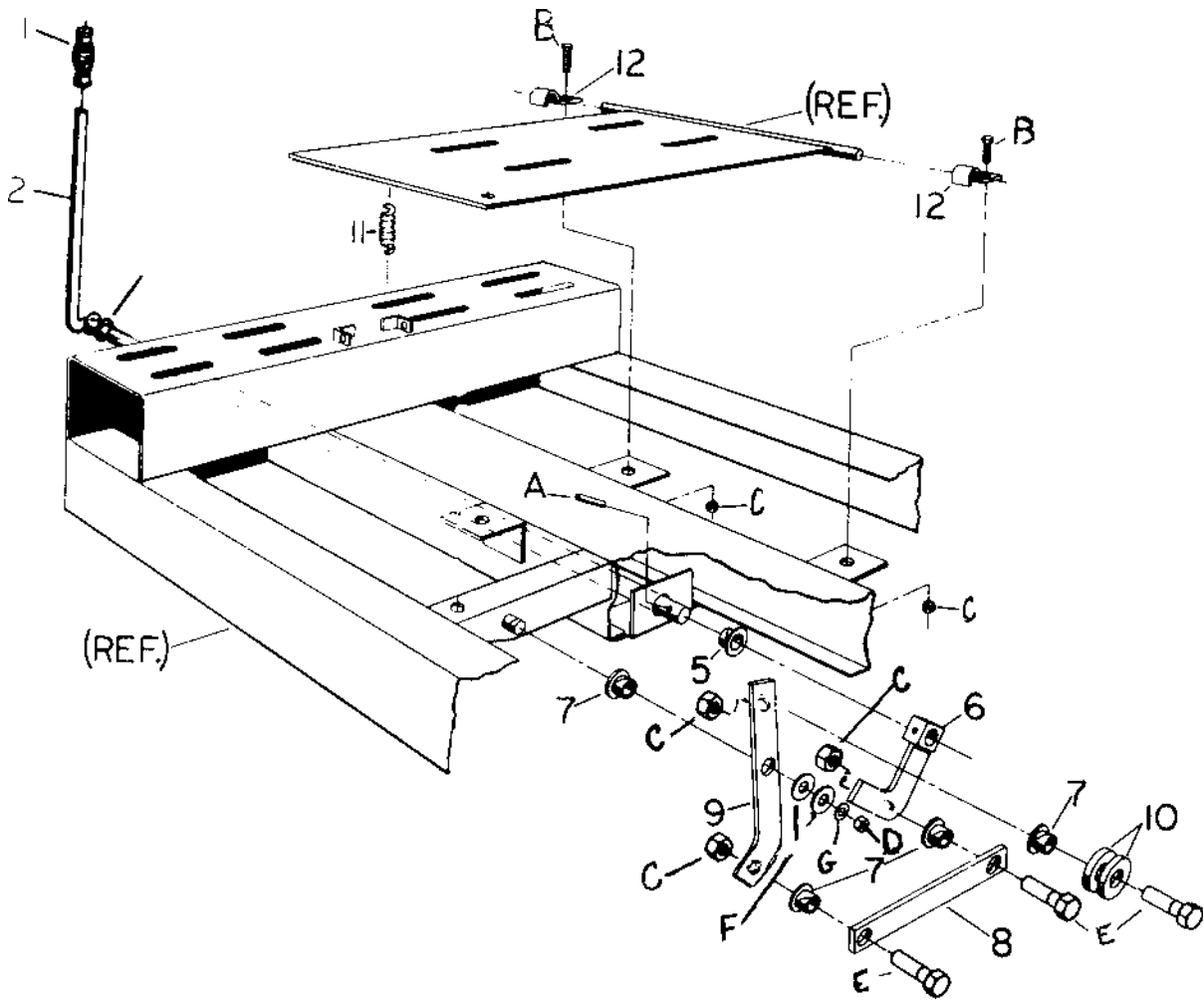

1050_clutch.tif

Parts List

1050PM Clutch Assembly

Item	Part No.	Description	Qty.
1	34687	Grip Handle 5/8	1
2	21504-2	Lever Clutch	1
3	32116	Flanged Nyliner	1
5	32098	Bushing Nylon	1
6	22524-2	Lever First	1
7	32099	Nyliner	4
8	26967-2	Lever Second	1
9	26965-2	Lever Third Assy	1
10	26326	WSHR 9/16 x 1-3/4 x 1/4	2
11	34849	Spring Motor Base	1
12	27575-2	Bracket Motor Base	2
A	80308	PINSP 1/4 x 1-1/2 ZN	1
B	80075	HHCS 1/2-13 x 1-1/4 ZN	2
C	80051	NUTNY 1/2-13 ZN	5
D	80056	NUTNY 3/8-16 ZN	1
E	80089	HHCS 1/2-13 x 1-3/4 ZN	3
F	80639	WSHRSP 1/2	2
G	80043	WSHR 3/8 WROT	1

Parts List

1265PM Clutch Assembly

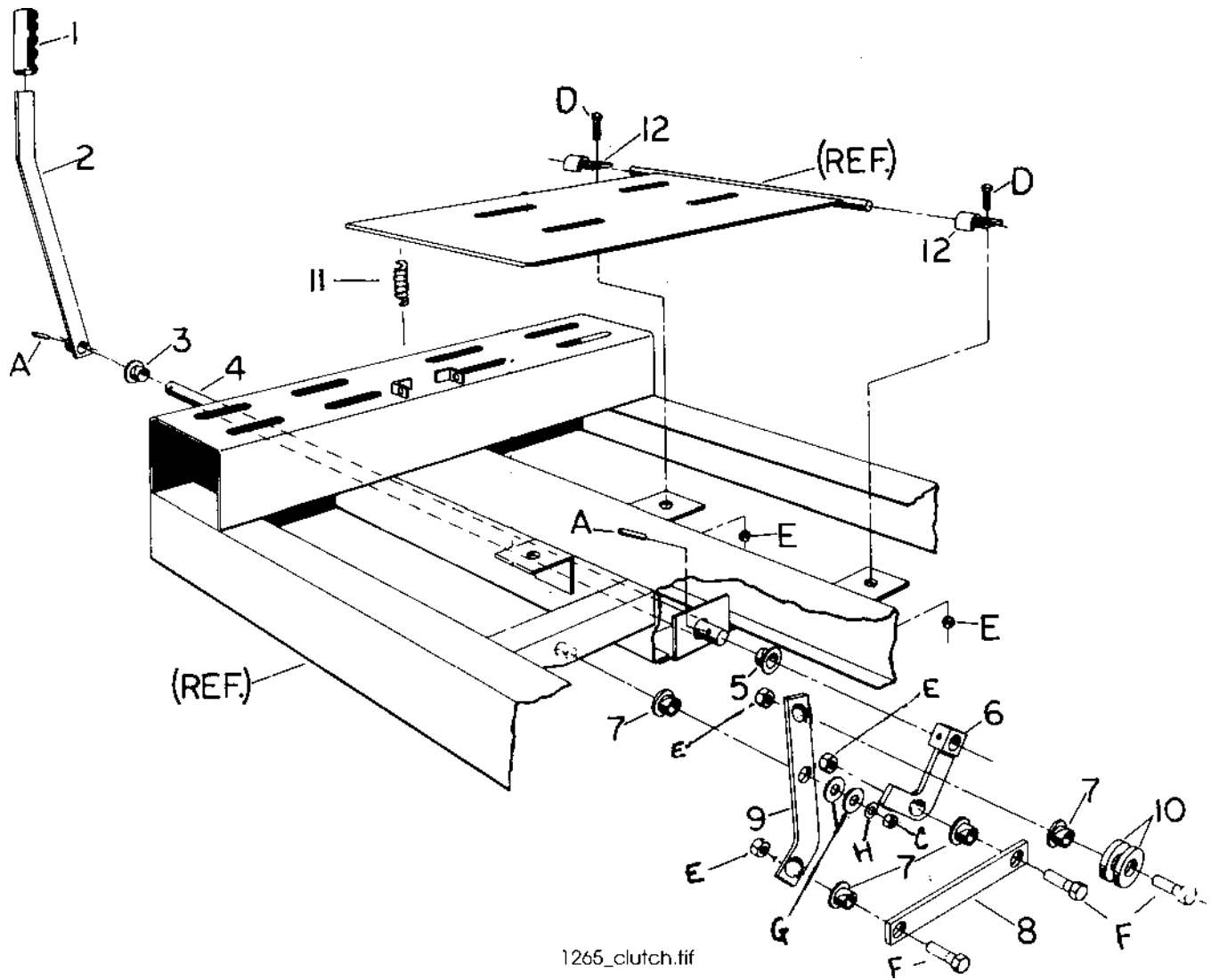

Parts List

1265PM Clutch Assembly

Item	Part No.	Description	Qty.
1	35296	Grip Handle Serrated 7/8 Diameter	1
2	22094-2	Lever Clutch	1
3	32116	Flanged Nyliner	1
4	28138-2	Rod Clutch	1
5	32098	Bushing Nylon	1
6	22524-2	Lever First	1
7	32099	Nyliner	4
8	26967-2	Lever Second	1
9	26965-2	Lever Third Assy	1
10	26326	WSHR 9/16 x 1-3/4 x 1/4	2
11	34849	Spring Motor Base	1
12	27575-2	Bracket Motor Base	2
A	80308	PINSP 1/4 x 1-1/2 ZN	2
C	80056	NUTNY 3/8-16 ZN	1
D	80075	HHCS 1/2-13 x 1-1/2 ZN	2
E	80051	NUTNY 1/2-13 ZN	5
F	80089	HHCS 1/2-13 x 1-3/4 ZN	3
G	80639	WSHRSP 1/2	2
H	80043	WSHR 3/8 WROT	1

Parts List

1285PM /1650PM Gearcase Assembly

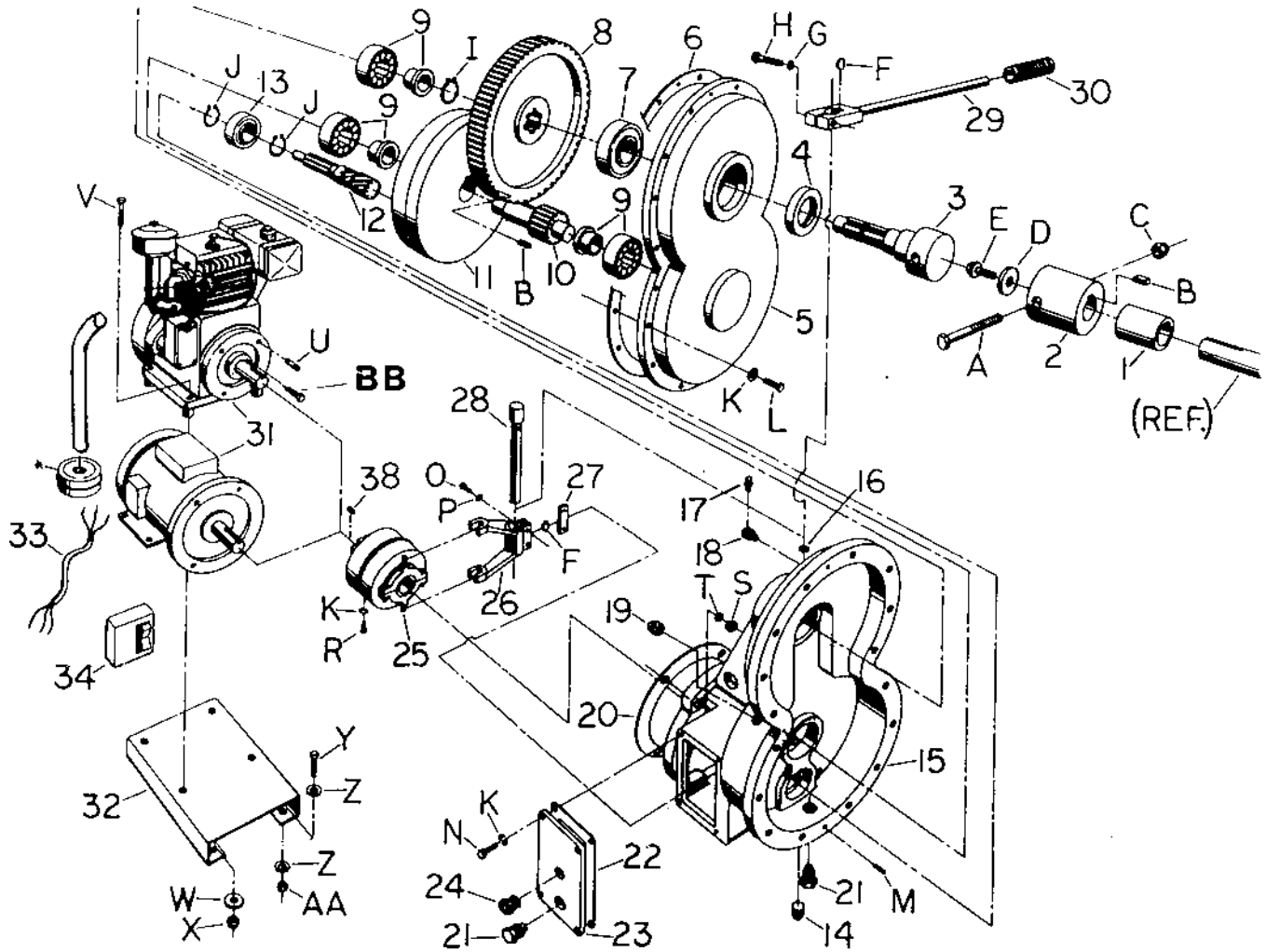

12_16_gc.tif

Parts List

1285PM /1650PM Gearcase Assembly

Item	Part No.	Description	Qty.
1	44284	Spacer	1
2	28087	Coupling Shaft	1
3	28092	Shaft Output GB	1
4	35295	Seal Output Shaft	1
5	28085	Cover Gearcase	1
6	28088	Gasket Gearcase	1
7	32177	Bearing Ball	1
8	28098	Gear Output	1
9	32101	Roller Bearing	3
10	28097	Pinion Output	1
11	28096	Gear Internal	1
12	28095	Input Shaft & Pinion	1
13	32213	Bearing	1
14	44332	Plug 7/8-14 O-Ring	1
15	28084	Gearcase	1
16	47180	O-Ring	1
17	46064	Breather	1
18	46062	Connection Elbow	1
19	46107	Pipe Plug 1/2 NPT SQ HD	1
20	27010	Gasket Adapter Engine	1
21	46108	Magnetic Plug 1/2 IN	2
22	32253	Gasket Access Cover	1
23	42461-2	Cover Clutch Access	1
24	34096	Oil Sight Plug	1
25	30089	Clutch Gearbox	1
26	28093	Clutch Fork	1
27	28181	Spacer Clutch Fork	1
28	28094	Shaft Clutch	1
29	22099-2	Handle Clutch	1
30	34765	Flex Grip	1
31	32342	Engine 11.5hp Robin	1
31b	28209	Engine 18hp B&S	1
31c	29809	Engine 11hp Honda 1285PM/1650PM	1
31d	28210	Motor 5hp Electric 1-Phase	1
31e	28211	Motor 5hp Electric 3-Phase	1

Parts List

1285PM /1650PM Gearcase Assembly

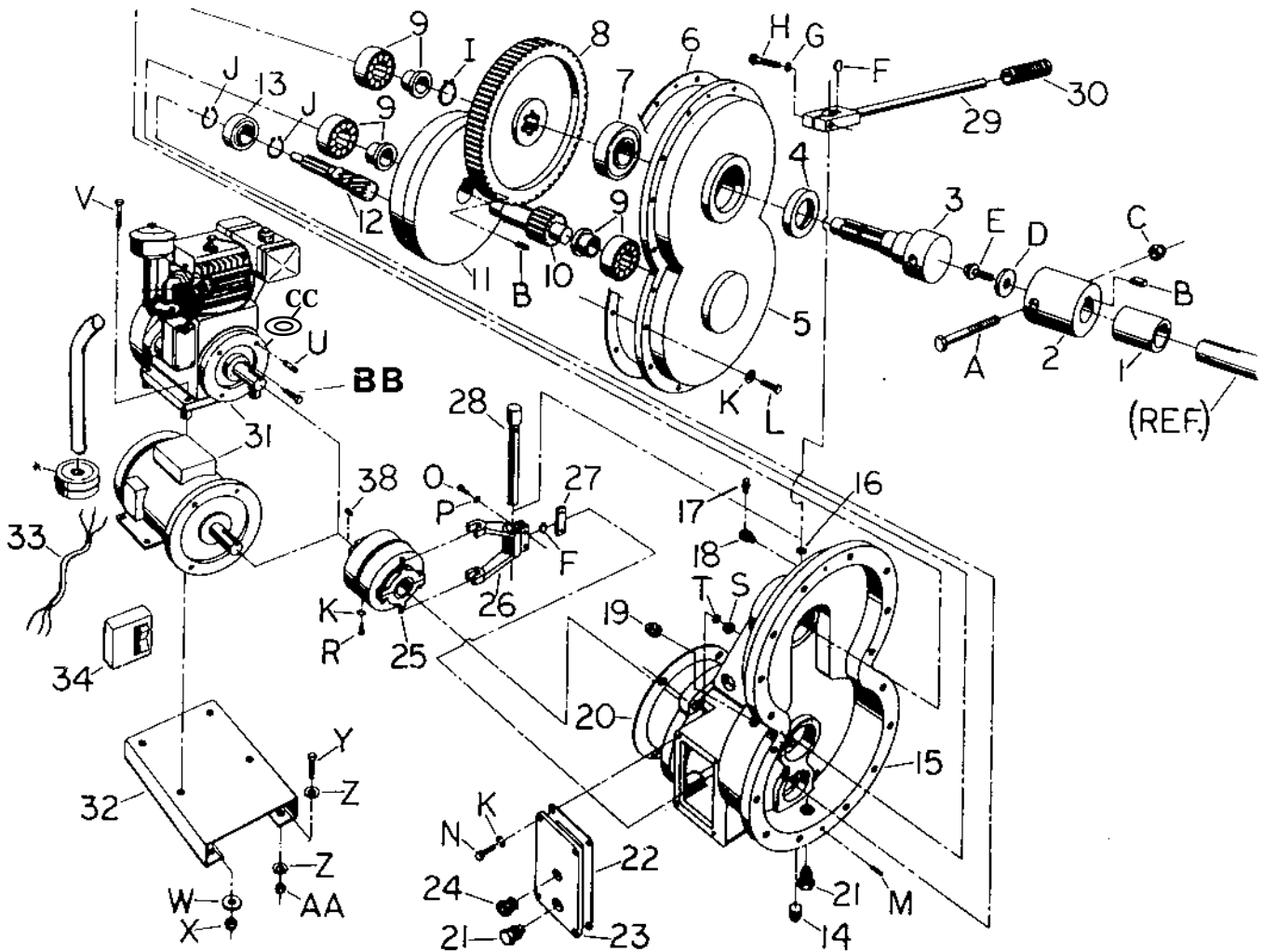

12_16_gc.tff

**ENGINE
SHAFT**

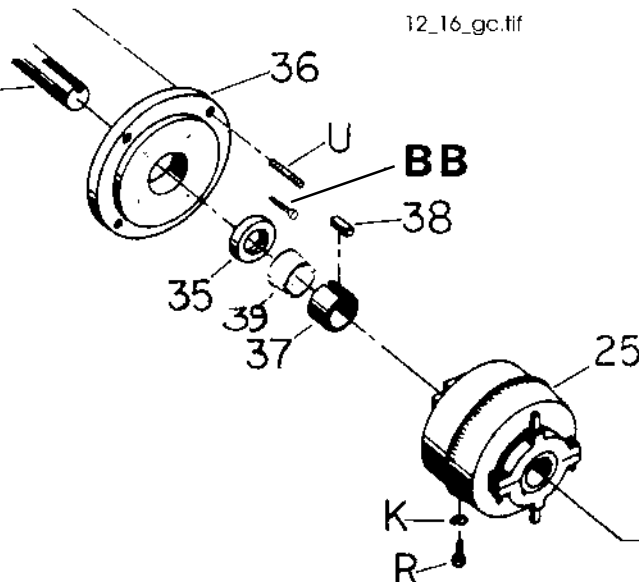

**18 hp B&S, 11 hp Honda and
11.5 hp Robin Only**

TO INPUT SHAFT

Parts List

1285PM /1650PM Gearcase Assembly

Item	Part No.	Description	Qty.
32	28399-2	Base Motor Honda	1
32b	28193-2	Base Motor Electric	1
32c^	28375-2	Base Motor Top B&S	1
32d^	28376-2	Base Motor Bottom B&S	1
33	36081	Pig Tail 1 Phase	1
33b	36082	Pig Tail 3 Phase	1
34	36020	Starter Manual 1 Phase	1
34b	36068	Starter Manual 3 Phase	1
35	32179	Oil Seal Honda/B&S	2
35b	38507	Oil Seal 11.5 hp Robin	
36	28398	Adapter Honda/11.5 hp Robin	1
36b	28202	Adapter B&S	1
37	27796	Bushing Clutch Adapter Honda/B&S/11.5 hp Robin	1
38	80100	Key Clutch Adapter Kohler/Electric	1
38b	27795	Key Clutch Adapter Honda/B&S/11.5 hp Robin	1
39	28844	Bushing Shaft Honda	1
39b	28267	Bushing Shaft B&S	1
40^	28374	Spacer Motor Base B&S	4
41^	22808	Kit Gas Tank B&S	1
42^	46059	Cap Fuel B&S	1
43^	34492	Clamp Hose B&S	2
44^	46186	Hose B&S	18"
45^	80104	HHCS 1/2-13x1-1/4 B&S	4
46^	80051	NUTNY 1/2-13 B&S	4
47^	35321	Battery B&S	1
48^	42672-2	Box Battery B&S	1
49^	42673-2	Bracket Hold Down 18hp B&S	1
50^	38114	Cable Battery 15" Blk 18hp B&S	1
51^	48284	Cable Battery 25" Red 18hp B&S	1
52^	47244	Rubber 1.5x6.75 B&S	3
53^	34783	Throttle B&S	1
54^	38121	Spring Governor	1
55^	22075	Gearcase Assy (Incl 3-13, 15, 19, 21, 23 & 24, B, I - N)	1

Note: + Use only Grade 2
* Seal with Silicone
^ Not Shown

Parts List

1285PM /1650PM Gearcase Assembly

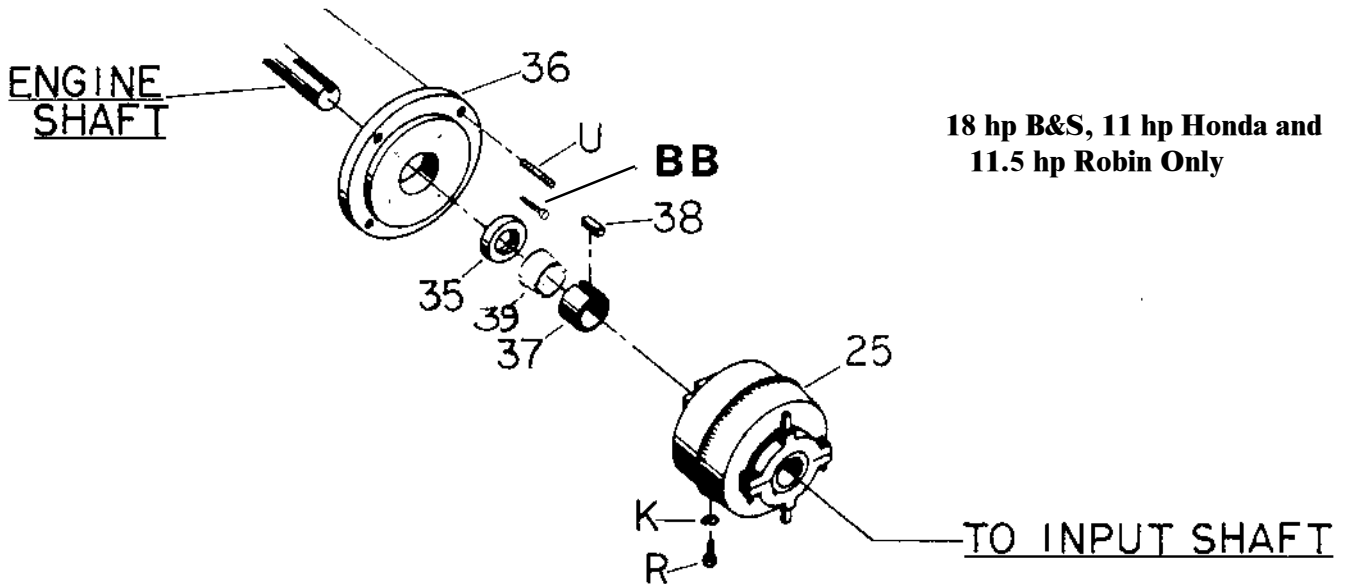
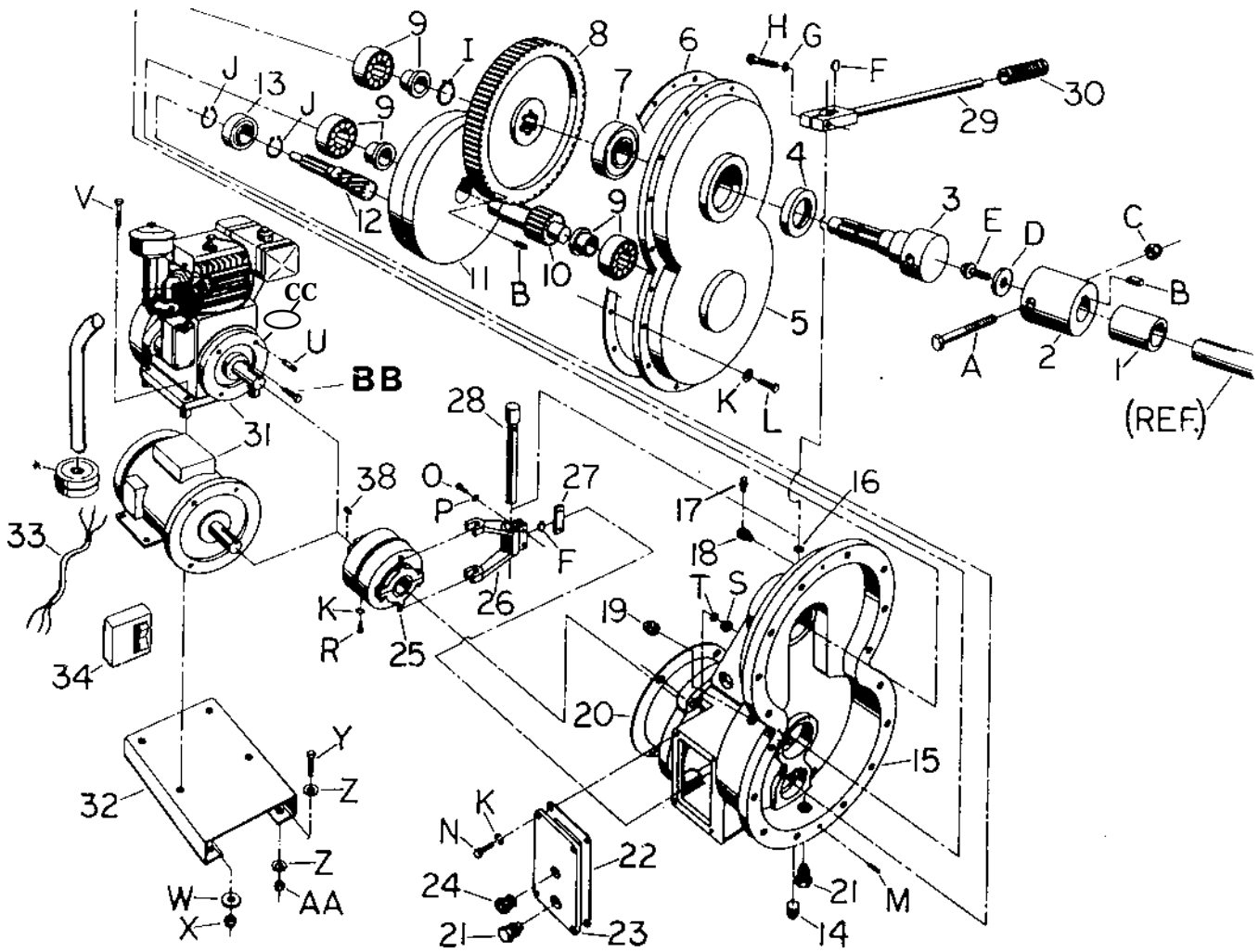

Parts List

1285PM /1650PM Gearcase Assembly

Item	Part No.	Description	Qty.
A+	80520	HHCS 5/8 - 11 X 4 - 1/2 ZN Shear Bolt	1
B	81060	KEY 3/8 X 1 - 1/2	2
C	80082	NUTNY 5/8 - 11 ZN	1
D	26326	WSHR 9/16 X 1 - 3/4 X 1/4	1
E	80075	HHCS 1/2 X 13 X 1 - 1/2 ZN	1
F	80097	Key Woodruff	2
G	80058	WSHRL 3/8 Med Split ZN	1
H	80176	HHCS 3/8 - 16 Z 1 - 1/2 ZN	1
I	80099	Ring Retaining	1
J	80098	Ring Retaining	2
K	80086	WSHRL 5/16 Med Split ZN	23
L	80439	SHCS 5/16 - 18 X 1 ZN	10
L2	80607	SHCS 5/16 - 18 X 2 ZN	6
M	80002	PINDL 1/4 X 5/8	2
N	80159	HHCS 5/16 - 18 X 3/4 ZN	6
O	80354	HHCS 1/4 - 20 X 1 ZN	2
P	80116	WSHRL 1/4 Med Split ZN	2
R	80508	HHBT 5/16 - 18 X 7/8 DG PT ZN	1
S	80248	NUTFX 7/16-14	4
T	80335	WSHRL 7/16 Med Split	4
U	80090	Stud 7/16-14x1-7/8	4
U2	80103	Stud 7/16-14x2-3/4 (18 B&S Only)	4
V	80178	HHCS 3/8-16 x 2 (11H/11.5 Robin)	4
V2	80169	HHCS 5/16-18 x 2 (18B&S)	4
V3	80145	HHCS 3/8-16 x 1-1/4 (Electric)	4
W	26325	WSHR Motor Base PM	4
X	80056	NUTNY 3/8-16 (11H, 5hp Electric/11.5hp Robin)	4
X2	80114	NUTNY 5/16-18 (18 B&S)	4
Y	80075	HHCS 1/2-13x1-1/2	4
Z	80343	WSHR 1/2 SAE	8
AA	80051	NUTNY 1/2-13	4
BB	29469	SHCS Mod 3/8-16x1 (Honda/11.5hp Robin)	4
CC	26326	WSHR 9/16 x 1-3/4 x 1/4 Pln	1

Note: + Use only Grade 2
* Seal with Silicone
^ Not Shown

Parts List

1285PM & 1650PM Clutch Assembly

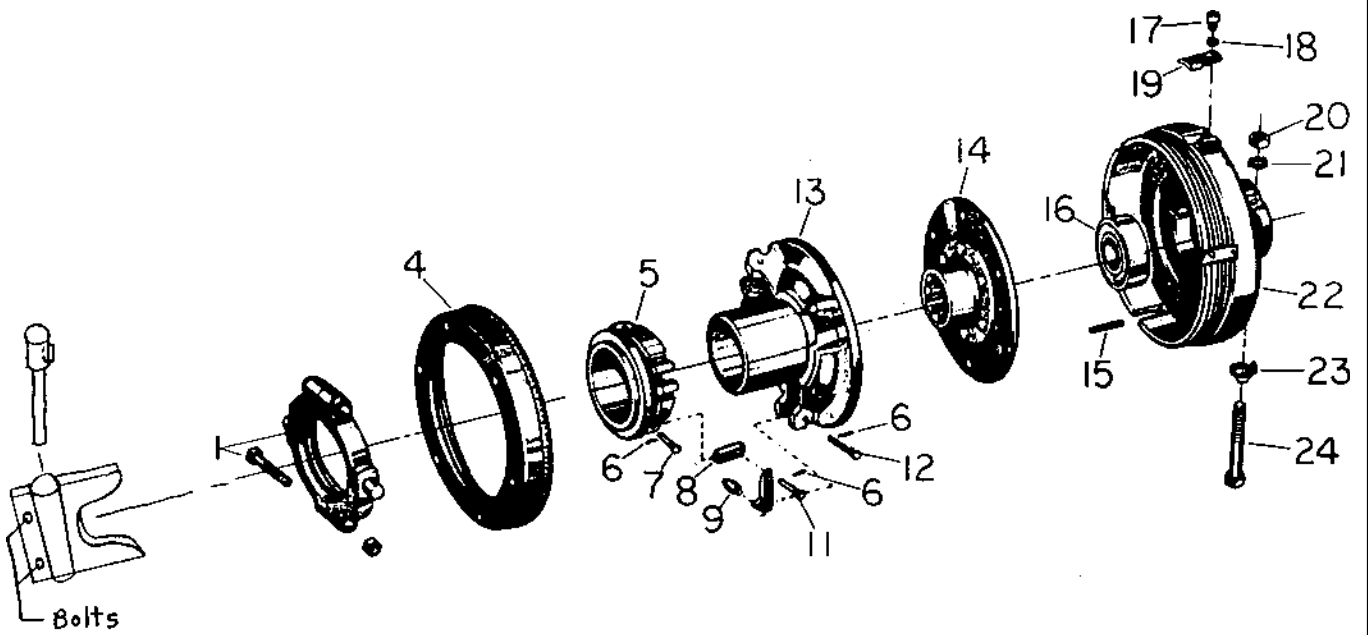

clutassy.tif

Parts List

1285PM & 1650PM Clutch Assembly

Item	Part No.	Description	Qty.
1	32146	Release Bearing (incl 2 HHCS 5/16 - 24 X 1 - 3/4/2 NUTNY 5/16 - 24)	1
4	32147	Adjustable Ring	1
5	32148	Release Sleeve	1
6	80533	PINCT 1/16 X 3/8	9
7	32185	Pin Clevis	3
8	32184	Connecting Link	6
9	32189	Roller Lever	3
10	32235	Release Sleeve/Lever	6
11	32188	Pin Clevis	3
12	32190	Pin Clevis	3
13	32149	Pressure Plate Assy	1
14	30121	Clutch Disc Rockford	1
15	32183	Spring	3
16	32182	Ball Bearing	1
17	80534	SLTD HHCS 1/4 - 20 X 3/8	1
18	80116	WSHRL 1/4 ZN	1
19	32191	Lock Adjusting	1
20	80242	NUTFX 3/8 - 24	2
21	80058	WSHRL 3/8 ZN	2
22	32150	Housing Clutch	1
23	38123	Lock Tab	2
24	80535	HHCS 3/8 - 24 X 2 - 1/2	2
25^	46042	Grease Fitting	1

Parts List

Spring Axle Assembly

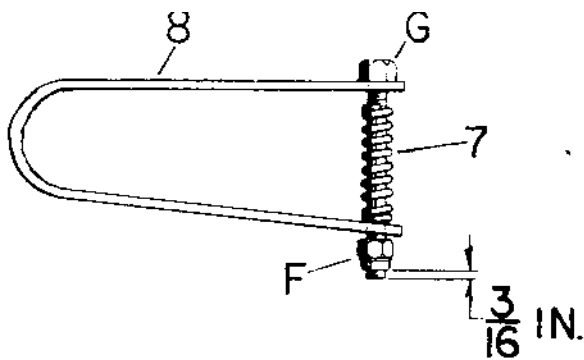

Thread bolt (Item G) through nut (Item F) approximately 3/16 inch as shown.

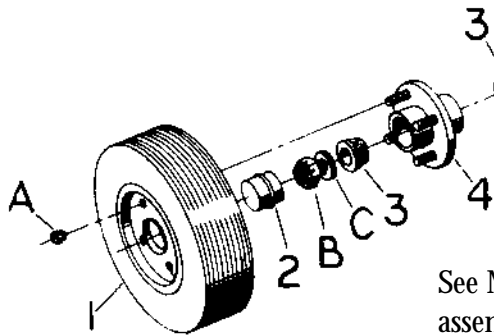
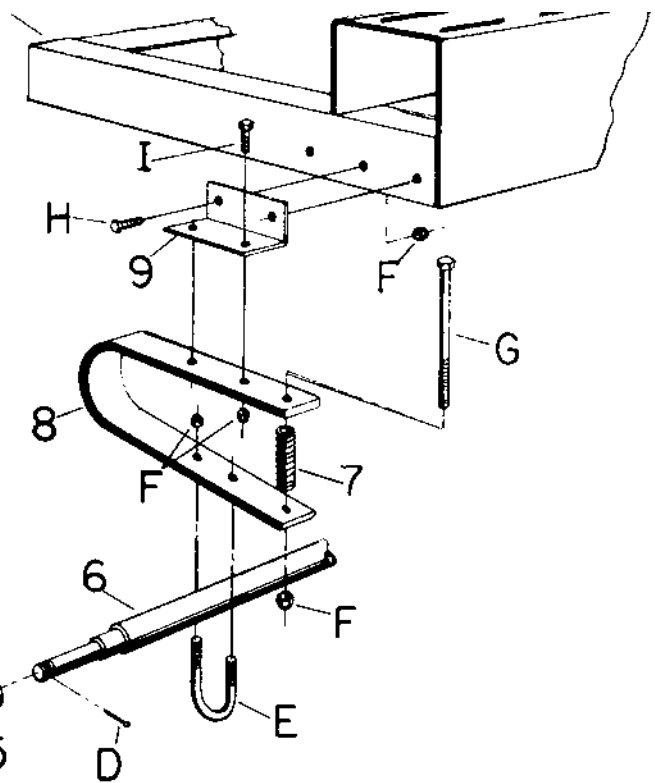

See Maintenance and Lubrication section for proper wheel assembly and torque specs.

Parts List

Spring Axle Assembly

Item	Part No.	Description	Qty.
1	32307	Tire/Rim Assy B78 x 13	2
2	34573	Dust Cap	2
3	32051	Bearing Cone	4
4	34501	Hub 4-bolt with tapered Bearing	2
5	32052	Seal Wheel Hub	2
6	21460-2	Axle 56" Spring	1
7	34972	Coil Spring	2
8	26971-2	Spring	2
9	26949-2	Bracket Spring	2
10^	21490	Axle/Hub Assembly Includes Items 2,3,4,5,6,B,C,D	1
A	80045	Lug Nut 1/2-20	8
B	80054	NUTSFX 3/4-16 SLTD ZN	2
C	80344	WSHR 3/4 SAE ZN	2
D	80316	PINCT 1/8x1-1/2 ZN	2
E	26195	U-Bolt 1/2-13	2
F	80051	NUTNY 1/2-13	14
G	80052	HHCS 1/2-13x6-1/2 ZN	2
I	80075	HHCS 1/2-13x1-1/2 ZN	8

Parts List

Trailer Lights Assembly Option

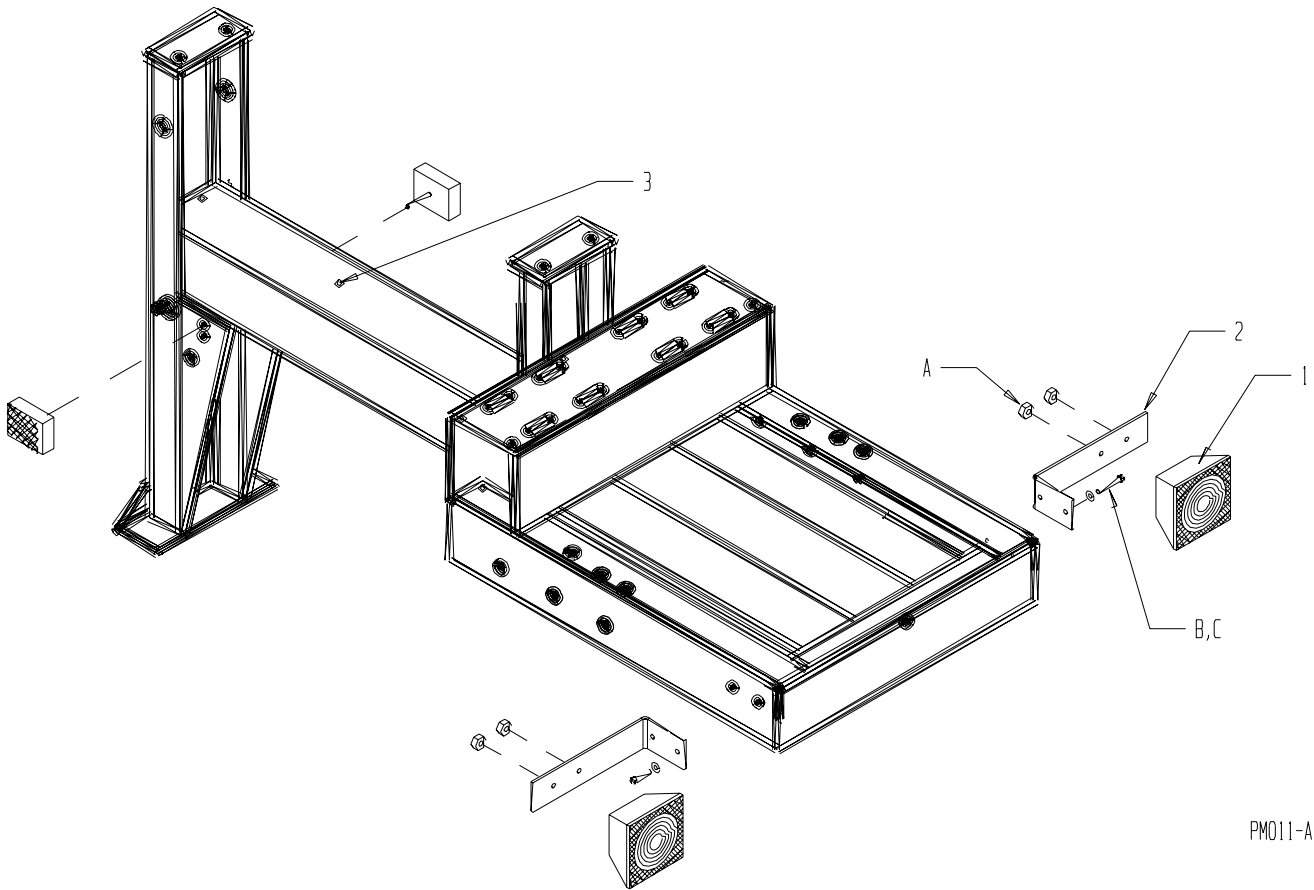

PM011-A

Parts List

Trailer Lights Assembly Option

Item	Part No.	Description	Qty.
1	36002	Trailer Lights	1
2	36003	Bracket Trailer Lights	2
3	48329	Tie Holder	10
4^	32087	Bushing Nylon 5/16 ID x 3/8 OD	1
5^	47303	Tie Tyton 4 inch Black	10
6^	48278	Term Fem .25 F-insul 14-16 gage	4
7^	48285	Term Male .25 F-insul 14-16 gage	4
8^	36001	Kit Trailer Lights (Includes 1,2,3,4,5,6,7,8,A,B,C)	1
A	80236	NUTKP 1/4 - 20 ZN	10
B	80347	WSHR 1/4 WROT ZN PL	4
C	80354	HHCS 1/4-20 x 1.00 ZN	4

Parts List

Exhaust Systems

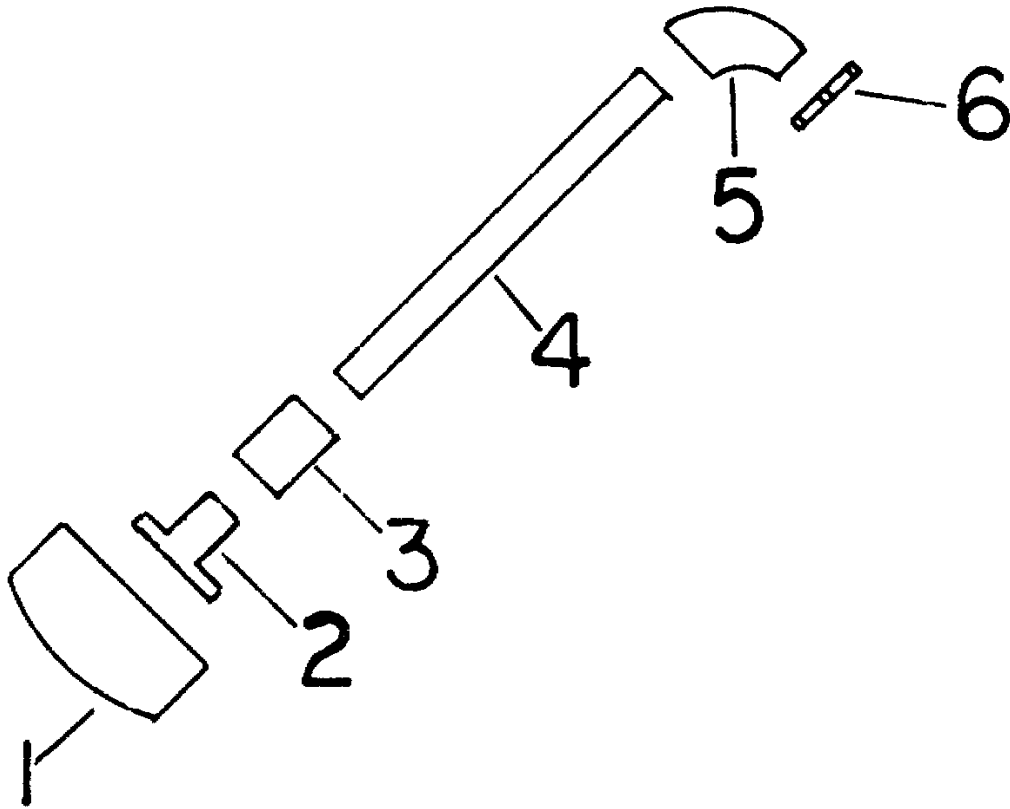

Parts List

Exhaust Systems

Item	Part No.	Description	Qty.
1	-	Muffler	2
2	46104	Muffler Adaptor B&S	2
3	46090	Coupling 3/4 inch Straight	2
4	46088	Nipple 3/4 x 9 inches	2
5	46103	Elbow 3/4 90 Straight	2
6	80375	Locknut 3/4 IPS Muffler Adapter	2

Parts List

Electric Wiring -1050PM and 1265PM

3 HP ELECTRIC WIRING / 1 PHASE
115 VOLT 36 AMP.
(H43 HEATER)

3 HP ELECTRIC WIRING / 1 PHASE
208-230 VOLT 19-18 AMP.
(H37 HEATER)

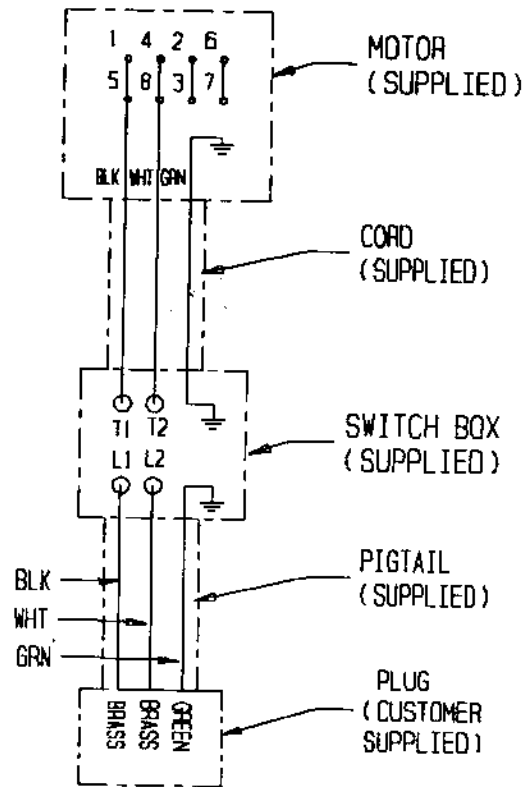
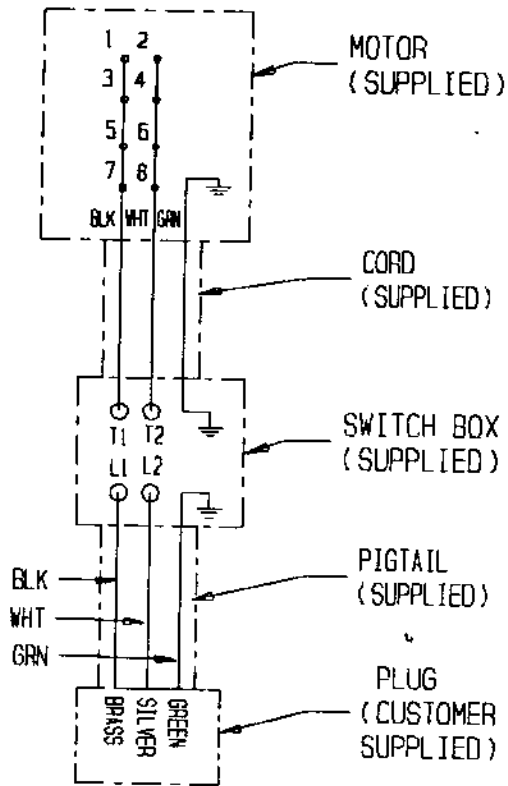

USE 12/3 EXTENSION
CORD OR BETTER FOR
POWER SUPPLY

USE 12/3 EXTENSION
CORD OR BETTER FOR
POWER SUPPLY

P/N 30014 MOTOR 3 HP 115V/230V 1 PH
MOTOR MFG: BALDOR
CAT NO: L1505

Parts List

Electric Wiring - 1285PM and 1650PM

5HP ELECTRIC WIRING / 1 PHASE
208-230 VOLT 14.8-14 AMP.
(H41 HEATER)

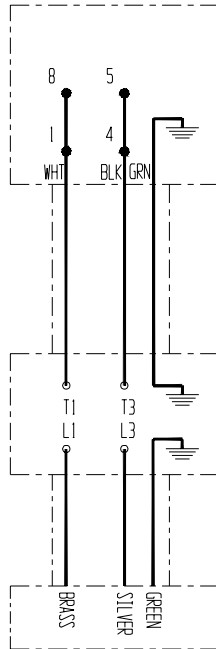

USE 12/3 EXTENSION
CORD OR BETTER FOR
POWER SUPPLY

5HP ELECTRIC WIRING / 3 PHASE
208-230 VOLT 14.8-14 AMP.
(H37 HEATER)

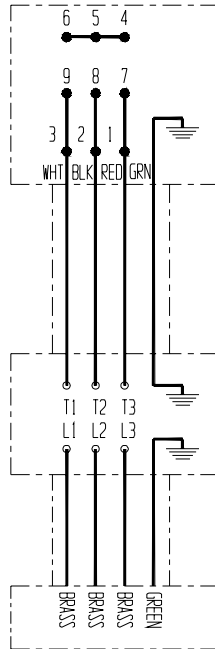

USE 12/4 EXTENSION
CORD OR BETTER FOR
POWER SUPPLY

5HP ELECTRIC WIRING / 3 PHASE
460 VOLT 7 AMP.
(H29 HEATER)

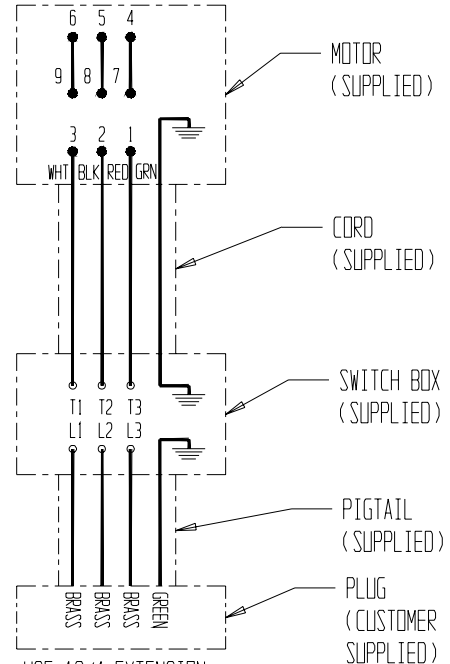

USE 12/4 EXTENSION
CORD OR BETTER FOR
POWER SUPPLY

ORIGINAL INSTALLATION OR FIELD REPLACEMENT
OF THIS MOTOR OR PLUG REQUIRES THE SHAFT
ROTATION TO BE COUNTERCLOCKWISE (CW).

P# 30099 MOTOR 5HP 230V 1PH
MOTOR MFG: BALDOR
SPEC NO.: 36E813-2385

P# 30098 MOTOR 5HP 230V/460V 3PH
MOTOR MFG: BALDOR
SPEC NO.: 36E812Y46

PROCEDURE FOR CHECKING ROTATION

BEFORE PROCEEDING: STARTER SWITCH
SHOULD BE IN THE "OFF" POSITION.

1. DISCONNECT SHEAVE AND BELTS FROM THE MOTOR/PUMP SHAFT.
2. TURN STARTER SWITCH "ON"
3. CHECK ROTATION, RELATIVE TO FACING END OF SHAFT (CW).
4. TURN STARTER SWITCH "OFF".
5. IF (CW) THEN REPEAT STEP 1 IN REVERSE ORDER. IF THE SHAFT ROTATES CLOCKWISE (CCW), WIRE TAPS MUST BE CHANGED TO ACHIEVE (CW) ROTATION.
6. UNPLUG STARTER FROM POWER SUPPLY
8. OPEN THE FRONT COVER TO STARTER BOX
9. INTERCHANGE ANY TWO LINE LEADS TO REVERSE ROTATION.
10. CLOSE STARTER BOX AND REPEAT STEP 1 IN REVERSE ORDER.

PM007B

Parts List

Decal Identification

⚠ WARNING



Do not run machine with cover open.

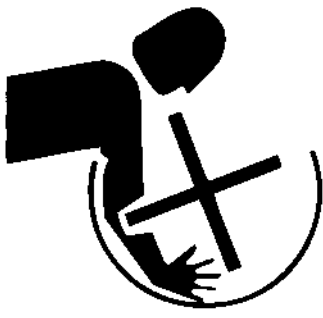

⚠ WARNING

Shut off machine to service or clean.

55010

⚠ WARNING

Always stop engine when cleaning or adjusting machine. If electric motor pull plug.

⚠ CAUTION



FOR YOUR SAFETY

- Read owner's service manual before operating or servicing this machine.
- Always keep unauthorized, inexperienced, untrained people away from this machine.
- Rotating and moving parts will cause injury if contacted. Make sure guards and safety devices are in place before this machine is operated.
- Make sure engine is shut down and spark plug wire disconnected before servicing the machine or approaching the moving parts- if electric motor, disconnect plug.
- Never leave machine unattended when operating. Always stop engine or motor before adding fuel or oil.

NOTICE

Contact the manufacturer immediately at 1-800-888-9926 if safety or hazard decals or owner's manual are missing from this equipment.



⚠ DANGER

GASOLINE
Stop engine and extinguish all flames and smoking materials before refueling. Use a safety can.

SAFETY CHAIN

"PATENT #4180281"

CROSS CHAIN UNDER TOW POLE WITH 4" - 5" VERTICAL SLACK

LATCH CHAIN AT DESIRED LENGTH

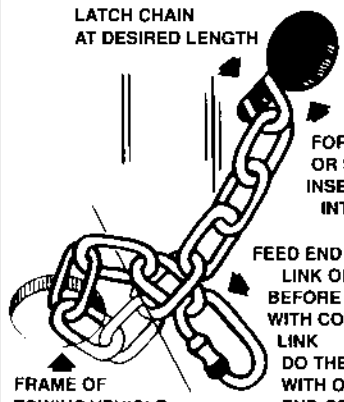

FOR EXCESS OR STORAGE, INSERT CHAIN INTO HOLE

FEED END THROUGH LINK OF CHAIN BEFORE SECURING WITH CONNECTING LINK
DO THE SAME WITH OPPOSITE END OF CHAIN

FRAME OF TOWING VEHICLE

CAUTION
READ OPERATING INSTRUCTIONS BEFORE RUNNING MIXER

55121

Parts List

Decal Identification

Item	Part No.	Description	Qty.
1^	55388	Kit Decals 655PM, 755PM, 855PM	1
2	55010	Decal Warning Shut Off	1
3	55011	Decal Warning Cover	1
4	55127	Decal Warning Stop Engine	1
5	55128	Decal Danger Gasoline	1
6	55156	Decal Notice Missing Decals	1
7	55046	Decal Safety Instructions	1
8^	55402	Kit Decals Standard Features, Grease and Safety	1
9	55119	Decal Stoner/Features	1
10	55121	Decal Caution Safety Chain	1
11	55007	Decal Grease Weekly Blue	1
12	55417	Decal Engine	1