



Count on it.

Parts Catalog

323

Compact Utility Loader

Model No. 22318—Serial No. 312000001 and Up



Ordering Replacement Parts

To order replacement parts, please supply the part number, the quantity, and the description of each part desired.

Understanding Reference Numbers

Each identified part in an illustration has a reference number. The reference number for a part also appears in the parts list, along with other information about the part.

This catalog uses two special reference number formats, one to indicate parts in a service assembly and another to indicate the quantity of a given part in an illustration.

Service Assembly Reference Numbers

Parts in service assemblies have reference numbers in the form a:b. The a represents the reference number of the entire service assembly and the b represents a sequential number unique to each part within the service assembly.

For example, a wheel assembly might be identified by reference number 6, the tire by 6:1, the valve by 6:2, and the wheel by 6:3. When you order the assembly identified by reference number 6, you receive all parts identified by reference numbers 6:1, 6:2, and 6:3. However, you may also order any part individually. Reference numbers of this type appear in illustration and in parts lists.

Reference Numbers Indicating Quantity

In an illustration, if a reference number indicates more than one part, the reference number has the form nX y. The n represents the quantity of the part, the X is the multiplication symbol, and the y represents the reference number.

For example, in an illustration, the reference number 2X 37 means that two of the parts identified by reference number 37 are indicated.

List of Abbreviations

AR: as required

ASM: assembly

BBC: blade brake control

BHTF: button head thread forming

CARR: carriage

CCW: counter clockwise

CW: clockwise

DEG: degrees

DPA: Dual Point Adjustment

ECM: electronic control module

EXT: external

FH: flat head

GA: gauge

HD: heavy-duty

HF: hex flange

HH: hex head

HHF: hex head flange

HHFTF: hex head flange thread forming

HJ: hex jam

HLH: hex lag head

HOC: height-of-cut

HSBH: hex socket button head

HSFH: hex socket flat head

HSH: hex socket head

HWH: hex washer head

HWHTF: hex washer head thread forming

HYD: hydraulic

LH: left hand

LPG: Liquid Propane Gas

NI: nylon insert

NPTF: national pipe thread fine

PFH: phillips flat head

PPH: phillips pan head

PPHTF: phillips pan head thread forming

PRH: phillips round head

PTH: phillips truss head

PTO: power-take-off

RH: right hand

ROPS: roll-over protection system

RRB: rear roller brush

SFH: slotted fillister head

SHH: slotted hex head

SHWH: slotted hex washer head

SPH: slotted pan head

SQH: square head

SRH: slotted round head

STD: standard

TAP: self tapping

TTH: torx truss head

Contents

Frame and Loader Arm Assembly	4
Hood and Screen Assembly	5
Wheel and Motor Assembly	6
Hydraulic Motor Assembly No. 99-3052	7
Engine and Pump Assembly	8
Hydraulic Motor Assembly No. 108-4710	10
Fuel Tank and Air Filter Assembly	11
Air Cleaner Assembly No. 117-9989	13
Hydraulic Tank and Filter Assembly	14
Auxiliary Control Lever Assembly	15
Hydraulic Valve Assembly	16
Auxiliary Hydraulic Valve Assembly No. 99-3077	17
Hydraulic Selector Valve Assembly No. 99-3072	18
Four Spool Valve Assembly	19
Four Spool Valve Assembly No. 105-8377	20
Hydraulic Motor Assembly	21
Counterbalance Valve Assembly No. 99-3040	22
Hydraulic Cylinder Assembly	23
Hydraulic Cylinder Assembly No. 105-7867	24
Electrical Component Assembly	25
Thigh Support Assembly	26
Fuel Tank Vent Assembly	27
Attachments and Accessories	28

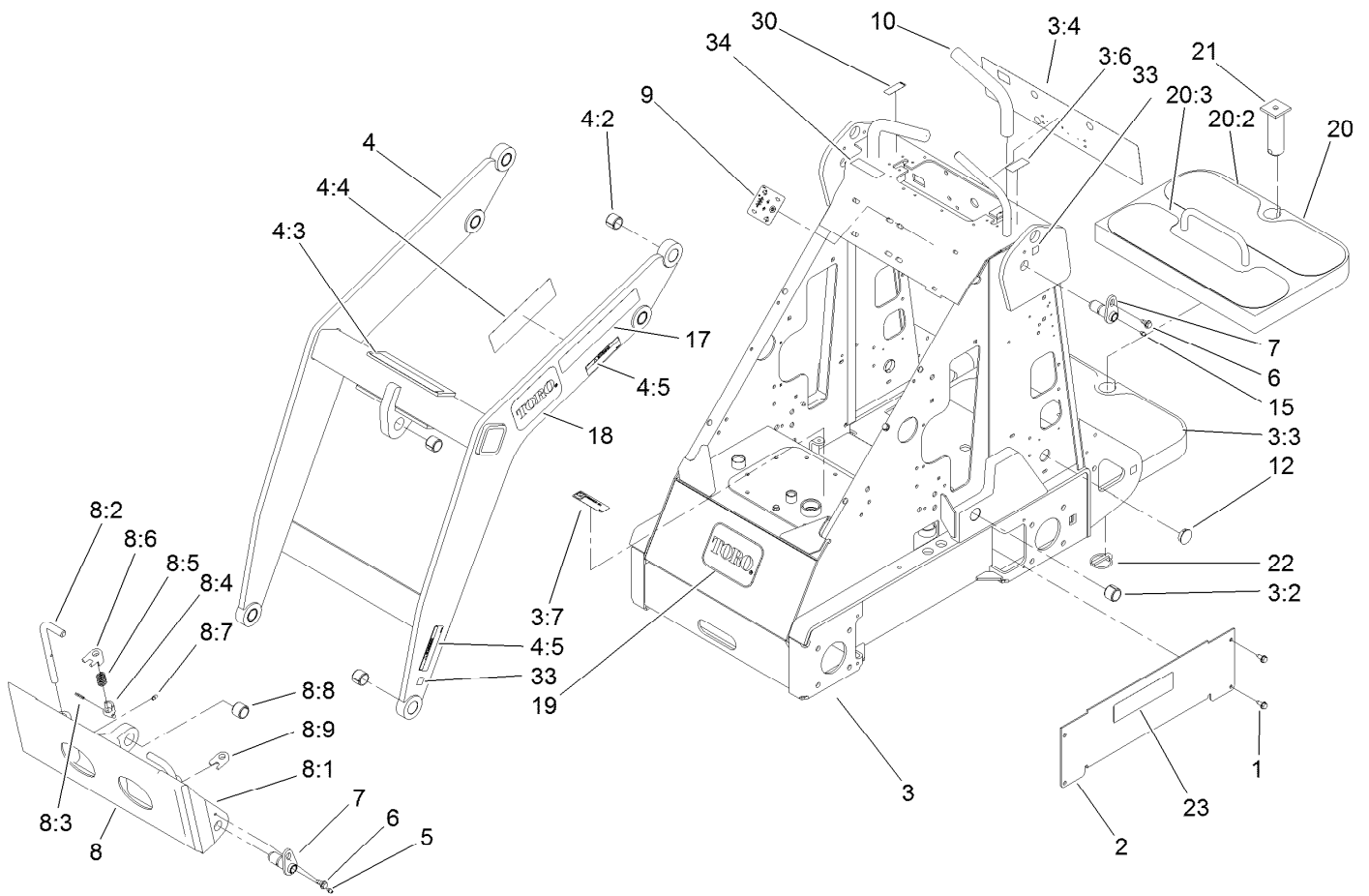

Frame and Loader Arm Assembly

Ref.	Part Number	Qty.	Description	Ref.	Part Number	Qty.	Description
1	32144-70	8	Screw-HWHTF	8:5	98-4694	2	Spring-Compression
2	106-8178-01	2	Cover-Hose	8:6	104-5909	1	Stop-RH
3	108-9710	1	Frame ASM	8:7	302-5	2	Fitting-Grease
3:2	98-4871	2	Bushing-Tension	8:8	98-4871	1	Bushing-Tension
3:3	98-9947	2	Tread-Foot	8:9	104-5903	1	Stop-LH
3:4	108-9732	1	Decal-Panel, Control	9	108-9716	1	Decal-Selector, Speed
3:6	98-8219	1	Decal-Throttle	10	98-4845	2	Grip-Cushion
3:7	93-6686	1	Decal-Oil, HYD	12	94-1402	2	Plug-Hole
4	106-8155	1	Loader ASM	15	120-5363	2	Pivot Pin ASM
4:2	98-4871	7	Bushing-Tension	17	117-9980	2	Decal
4:3	98-4682	1	Decal-Caution	18	93-7340	2	Decal
4:4	98-9051	1	Decal-Danger	19	62-5550	1	Decal
4:5	100-6141	4	Decal-Pinch	20	112-4947	1	Counterweight ASM
5	302-5	4	Fitting-Grease	20:2	98-9947	1	Tread-Foot
6	99-5105	4	Bolt-Shoulder	20:3	112-4948	1	Tread
7	112-2609	2	Pivot Pin ASM	21	99-8638	1	Pin ASM
8	115-0788	1	Quick Attach ASM	22	99-9978	1	Pin-Lynch
8:1	115-0774-03	1	Mount-Qtach	23	105-8429	2	Decal
8:2	105-8367	2	Pin-Locking	30	94-2551	1	Decal-Choke
8:3	3285-1	2	Pin-Grooved	33	93-9084	6	Decal-Point, Lift
8:4	105-0246	2	Cam	34	117-2718	1	Decal-Arrester, Spark

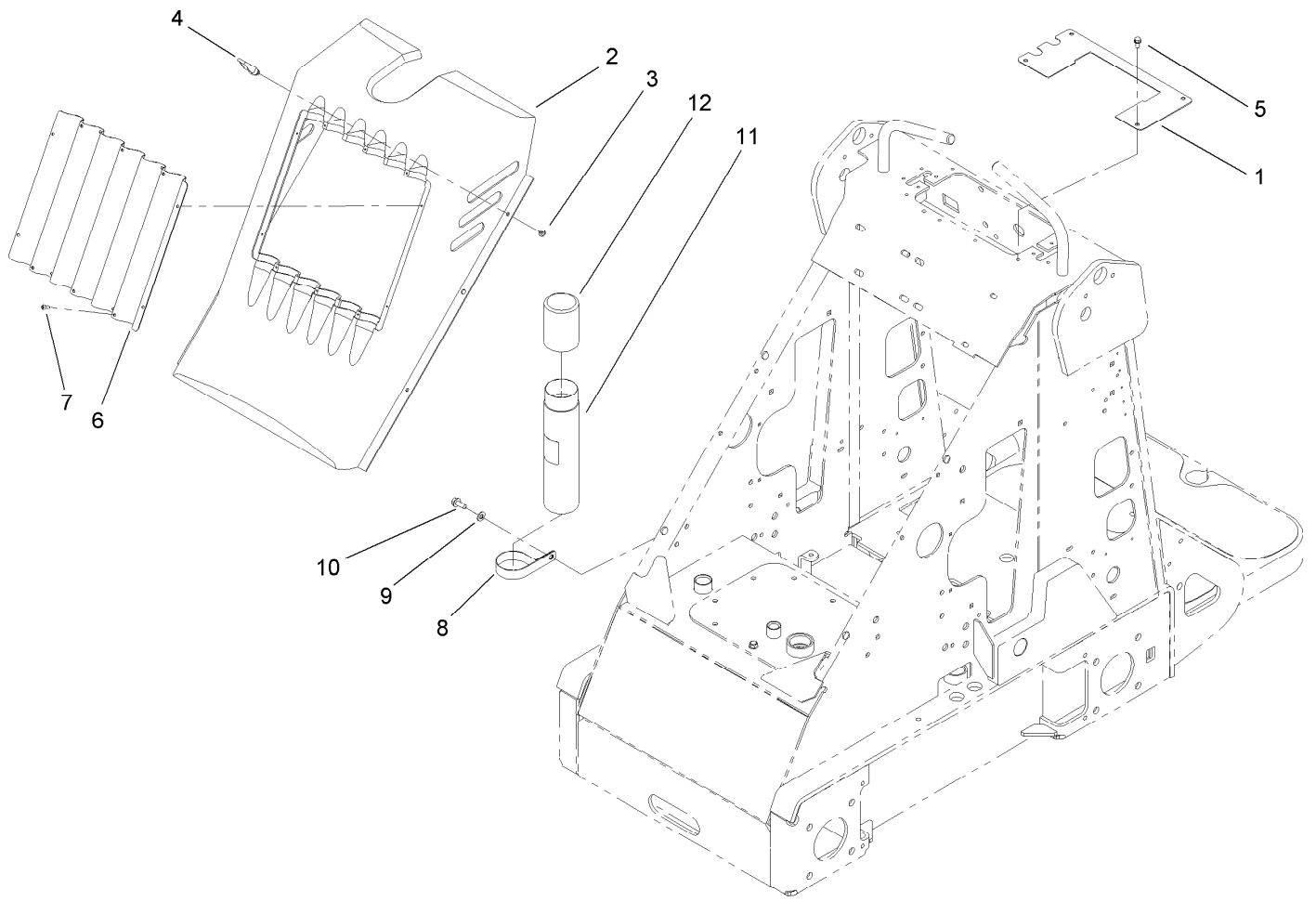

Hood and Screen Assembly

<i>Ref.</i>	<i>Part Number</i>	<i>Qty.</i>	<i>Description</i>
1	108-9731-03	1	Plate-Cover
2	99-3164	1	Cover-Hood
3	99-3058	4	Washer
4	74-5950	4	Latch-Swell
5	32144-4	4	Screw-HWH
6	99-3147-03	1	Grille-Screen
7	32144-111	10	Screw-PPH
8	2412-133	1	R-Clamp
9	3256-23	1	Washer-Flat
10	32144-70	1	Screw-HWHTF
11	104-7050	1	Tube-Manual
12	104-7048	1	Cap-Housing

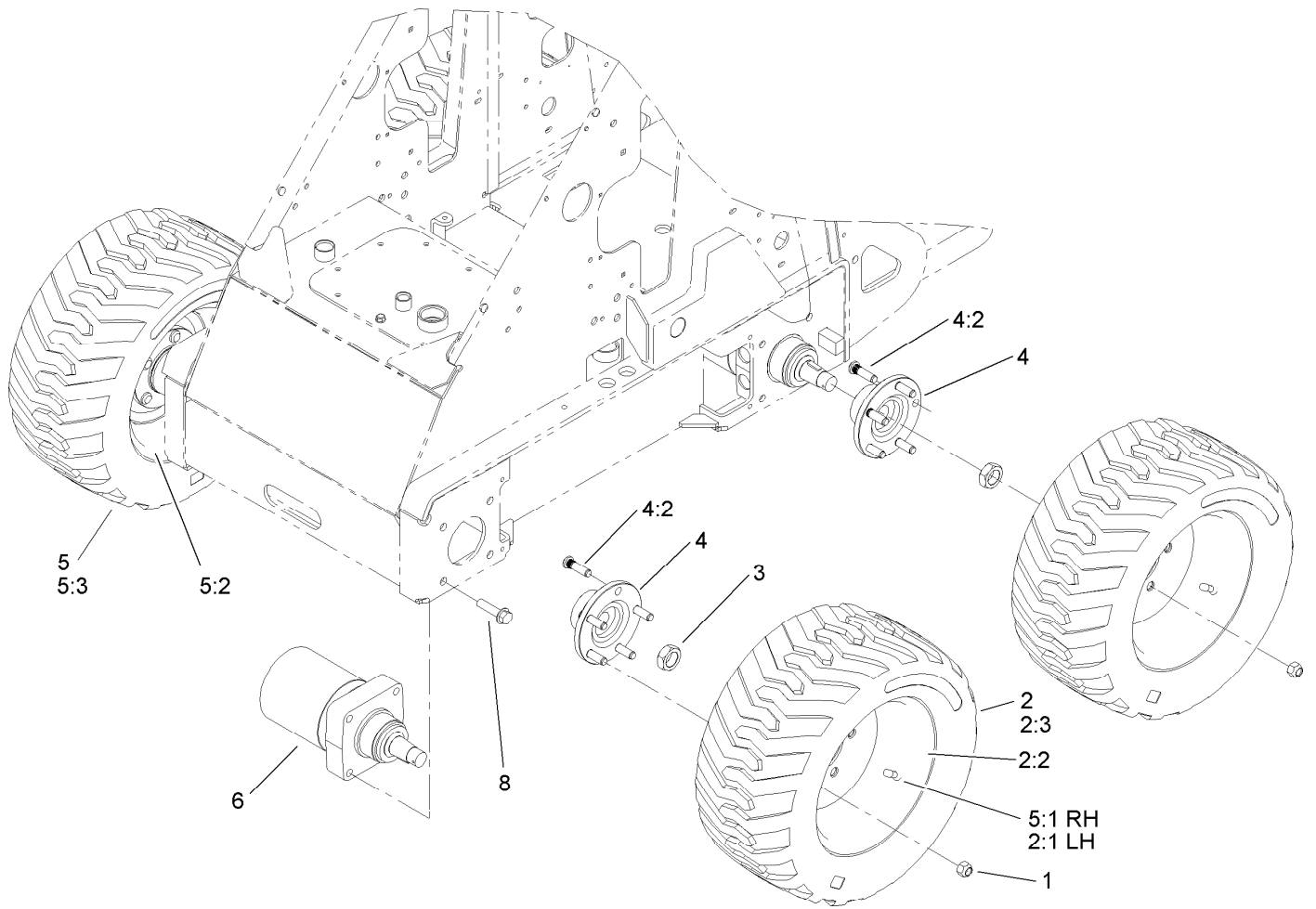

Wheel and Motor Assembly

Ref.	Part Number	Qty.	Description
1	242-50	20	Nut-Lug
2	98-2747	2	LH Wheel And Tire ASM
2:1	232-27	1	Stem-Valve
2:2	98-2748	1	Wheel
2:3	98-2749	1	Tire
3	106-8159	4	Nut-Lock
4	99-3064	4	Hub ASM
4:2	10-6830	5	Stud-Type, Drive
5	99-1447	2	RH Wheel And Tire ASM
5:1	232-27	1	Stem-Valve
5:2	98-2748	1	Wheel
5:3	98-2749	1	Tire
6	99-3052	4	HYD Motor ASM
8	3234-27	16	Screw-HHF

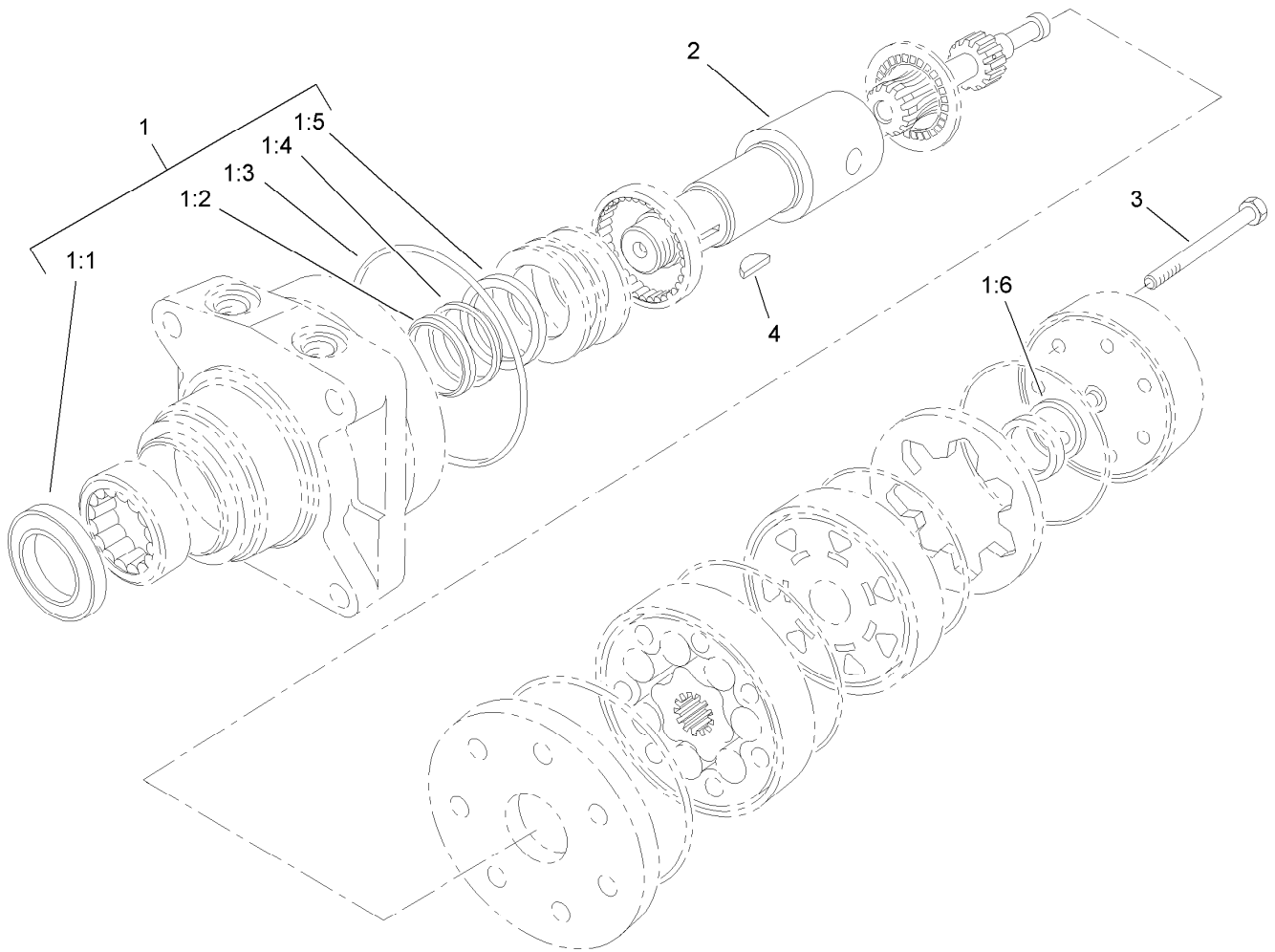

Hydraulic Motor Assembly No. 99-3052

<i>Ref.</i>	<i>Part Number</i>	<i>Qty.</i>	<i>Description</i>
1	94-8178	1	Seal Kit
1:1		1	Seal-Dirt And Water ●
1:2		1	Backup-Ring ●
1:3		1	Seal-Shaft ●
1:4		1	Washer-Backup ●
1:5		5	Seal-Square, Ring (Inner) ●
1:6		1	Seal-Commutator ●
2	99-3090	1	Shaft-Coupling
3	99-3091	7	Screw-Cap, HH
4	3257-42	1	Key-Woodruff

● Not serviced separately

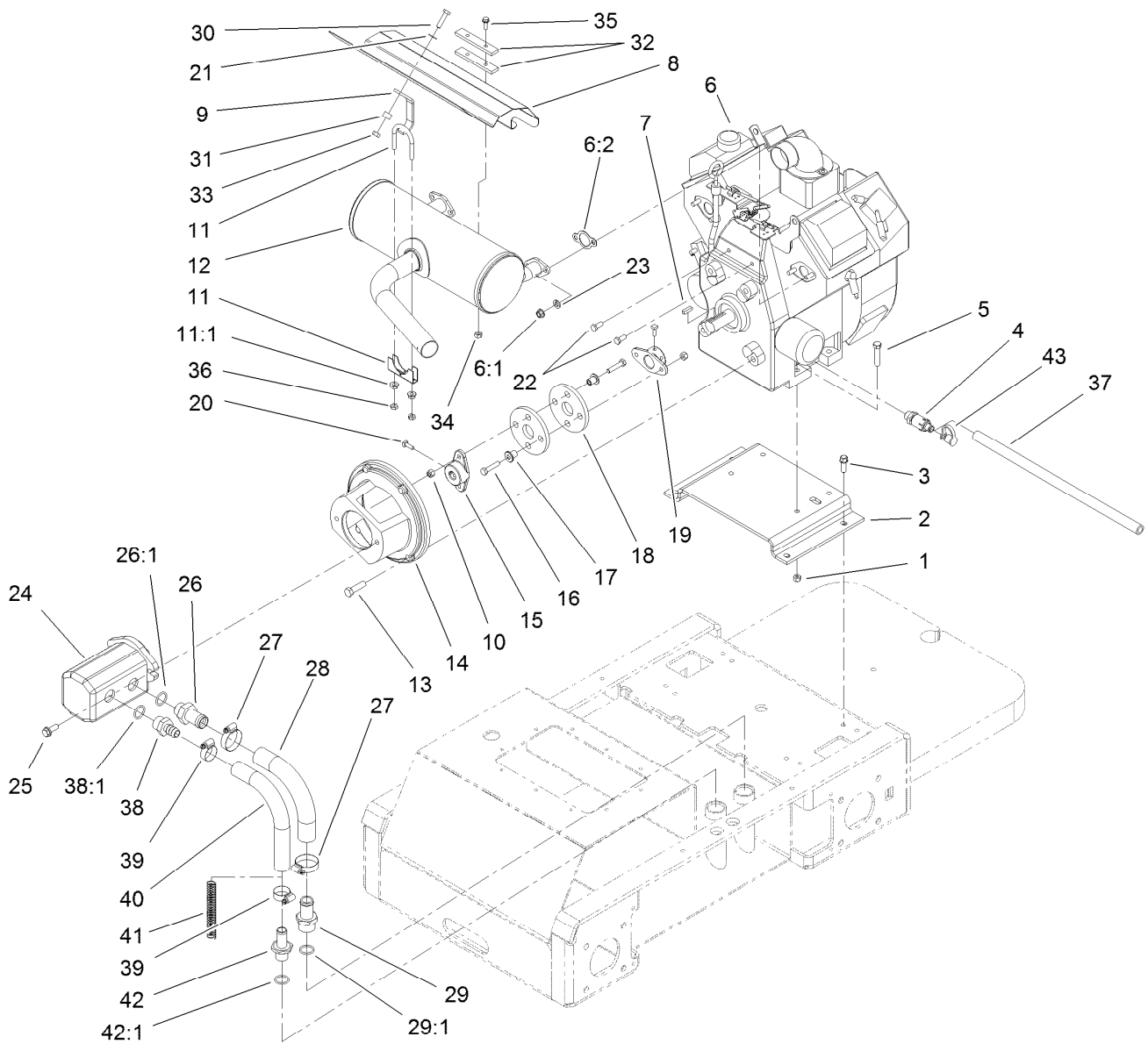

Engine and Pump Assembly

Ref.	Part Number	Qty.	Description	Ref.	Part Number	Qty.	Description
1	3296-39	4	Nut-Lock, NI	19	110-5236	1	Hub-Engine
2	98-4666-03	1	Mount-Engine	20	3241-6	4	Screw-SQH
3	95-1726	4	Screw-Taptite	21	3256-23	1	Washer-Flat
4	92-6877	1	Valve-Drain, Oil	22	33114-020	2	Screw-HH
5	323-9	4	Screw-HH	23	3253-4	4	Washer-Lock
6	117-1746	1	Engine-Kohler, Ch680S	24	108-4710	1	HYD Pump ASM
6:1	92-6780	4	Nut-HF	25	66-9300	2	Screw-HHF
6:2	110-6697	2	Gasket-Exhaust	26	99-3017	1	Fitting
7	10-7070	1	Key-Square	26:1	237-81	1	O-Ring
8	99-3115-03	1	Shield-Muffler	27	2412-111	2	Clamp
9	99-3138-03	1	Support-Shield	28	99-3046	1	Hose-Suction, Formed
10	3296-29	4	Nut-Lock, NI	29	354-78	1	Connector-Hose
11	2112-9	1	Clamp	29:1	237-146	1	O-Ring
11:1	32128-20	2	Nut-HF	30	322-6	1	Screw-HH
12	105-8381	1	Muffler	31	98-4695	1	Spacer
13	324-6	4	Screw-HH	32	99-3116-03	2	Spacer-Bar
14	98-2751-03	1	Mount-Pump	33	32152-1	1	Nut-Lock, Cone
15	98-4701	1	Hub-Pump	34	32152-4	2	Nut-Lock, Cone
16	322-7	4	Screw-HH	35	3234-21	2	Screw-HHF
17	71-4411	4	Spacer	36	3218-2	2	Nut-Jam
18	115-4523	2	Coupling-Rubber	37	98-4667	1	Hose

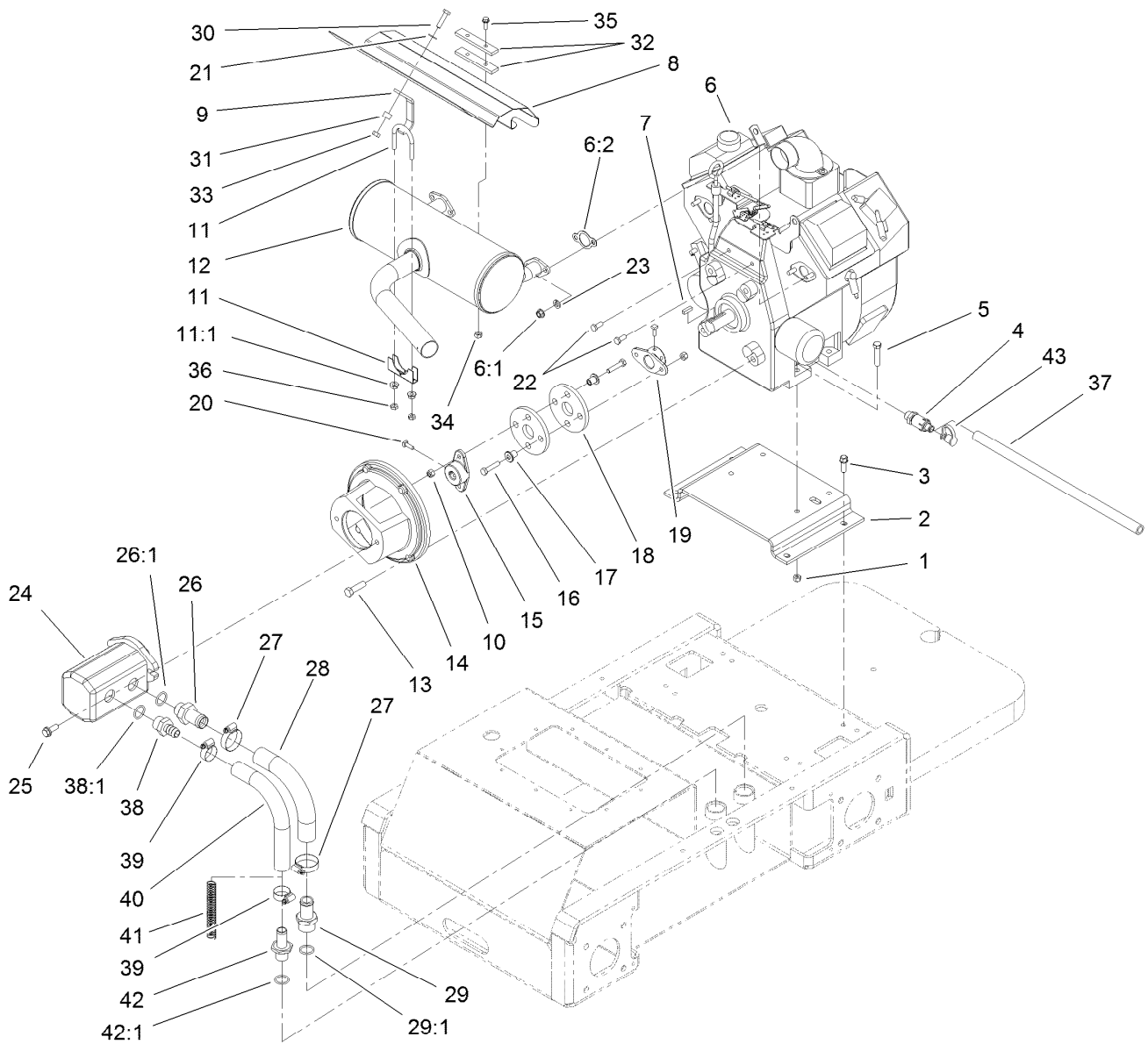

Engine and Pump Assembly (continued)

<i>Ref.</i>	<i>Part Number</i>	<i>Qty.</i>	<i>Description</i>	<i>Ref.</i>	<i>Part Number</i>	<i>Qty.</i>	<i>Description</i>
38	354-73	1	Fitting-Straight	41	99-5349	1	Spring-Compression
38:1	237-81	1	O-Ring	42	99-6932	1	Fitting-Hose, Barbed
39	2412-129	2	Clamp-Hose	42:1	237-117	1	O-Ring
40	98-2713	1	Hose-Suction, HYD	43	354-79	1	Cap-Dust

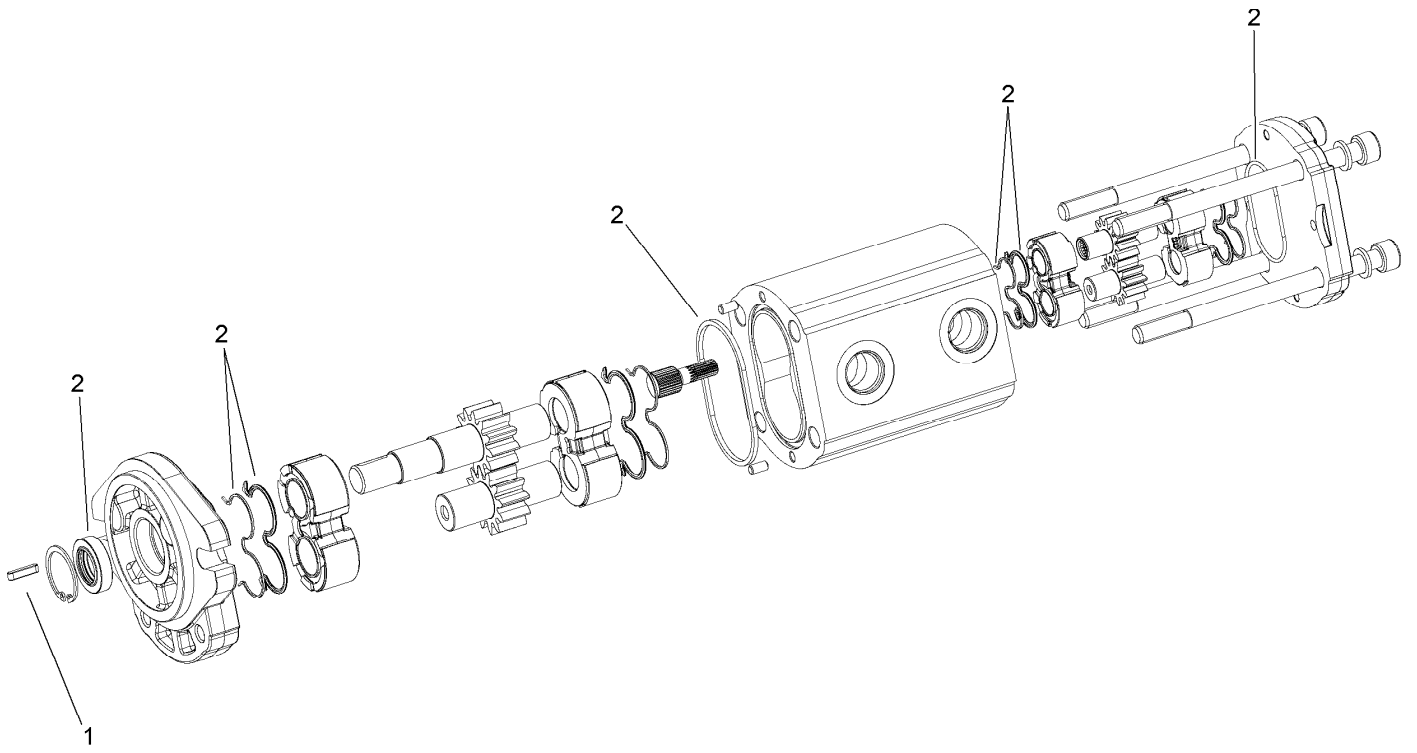

Hydraulic Motor Assembly No. 108-4710

<i>Ref.</i>	<i>Part Number</i>	<i>Qty.</i>	<i>Description</i>
1	98-4700	1	Key-Square
2	99-1353	1	Seal Kit

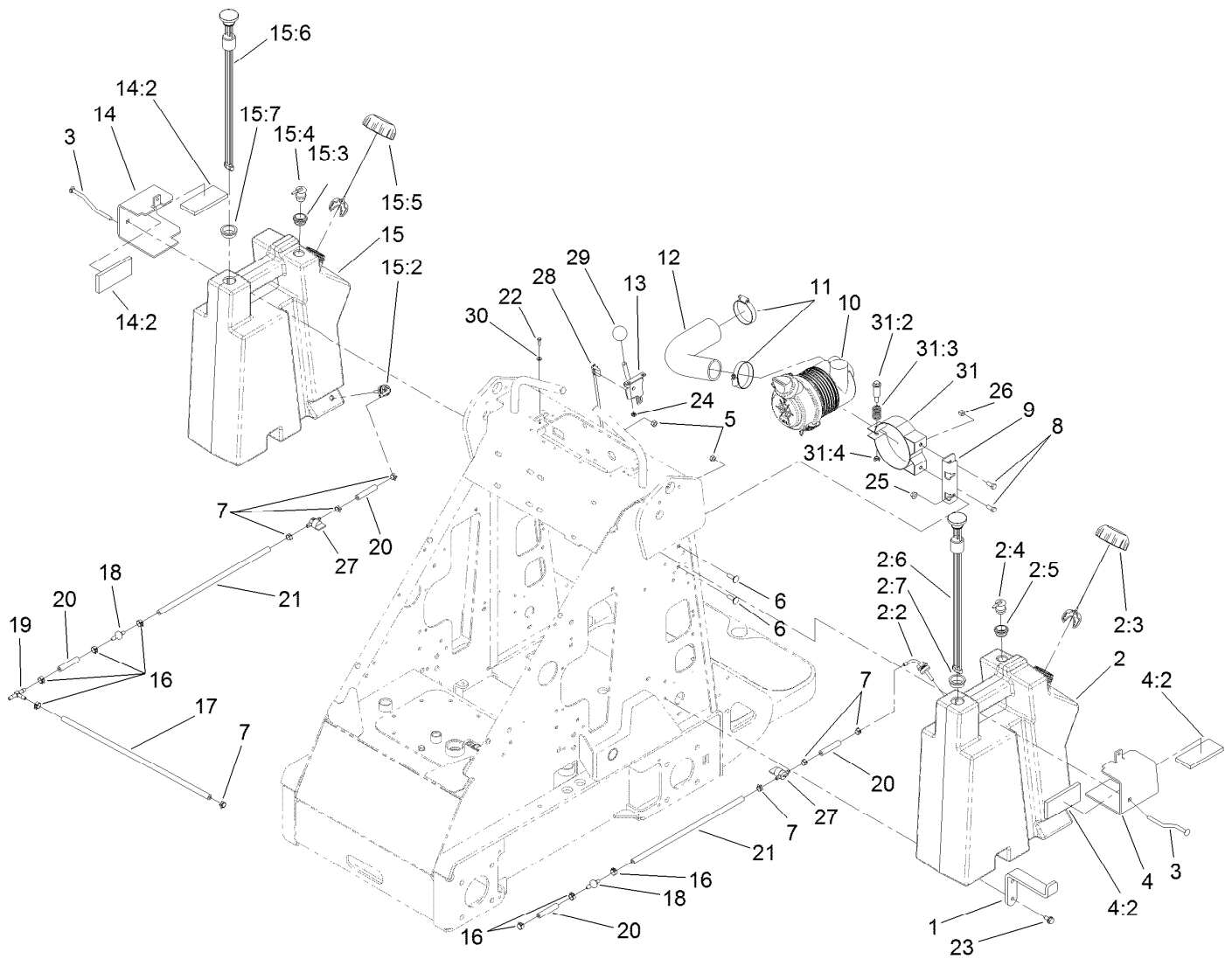

Fuel Tank and Air Filter Assembly

Ref.	Part Number	Qty.	Description	Ref.	Part Number	Qty.	Description
1	117-1777-03	2	Mount-Tank, Bottom	14:2	117-1798	2	Pad-Foam
2	119-5240	1	LH Fuel Tank ASM	15	119-5241	1	RH Fuel Tank ASM
2:2	103-2605	1	Fitting-Fuel, Bulkhead	15:2	103-2605	1	Fitting-Fuel, Bulkhead
2:3	115-7788	1	Cap-Fuel	15:3	115-7788	1	Cap-Fuel
2:4	114-0285	1	Valve-Rollover	15:4	114-0285	1	Valve-Rollover
2:5	114-0284	1	Grommet	15:5	114-0284	1	Grommet
2:6	104-5603	1	Gauge-Level, Fuel	15:6	104-5603	1	Gauge-Level, Fuel
2:7	95-8972	1	Grommet	15:7	95-8972	1	Grommet
3	98-4657	2	Bolt-Mount	16	92-2379	7	Clamp-Hose
4	117-1801	1	LH Tank Mount ASM	17	110-5701	1	Hose-Fuel
4:2	117-1798	2	Pad-Foam	18	99-5000	2	Valve-Check, Fuel
5	32153-3	2	Nut-Hex, Side Deform	19	99-5005	1	Fitting-Tee, Barbed
6	3230-2	2	Bolt-CARR	20	109-0304	4	Hose-Fuel
7	2412-98	7	Clamp-Hose	21	109-0296	2	Hose-Fuel
8	322-3	2	Screw-HH	22	3290-134	4	Screw
9	99-3080-03	1	Mount-Cleaner, Air	23	32144-70	4	Screw-HWHTF
10	117-9989	1	Air Cleaner ASM	24	32149-7	4	Nut-Keps
11	2412-42	2	Clamp-Hose	25	32128-20	2	Nut-HF
12	99-3148	1	Hose-Air	26	3296-29	2	Nut-Lock, NI
13	108-9730	2	Control Lever ASM	27	1-603770	2	Valve-Fuel
14	117-1802	1	RH Tank Mount ASM	28	108-4718	2	Cable-Control

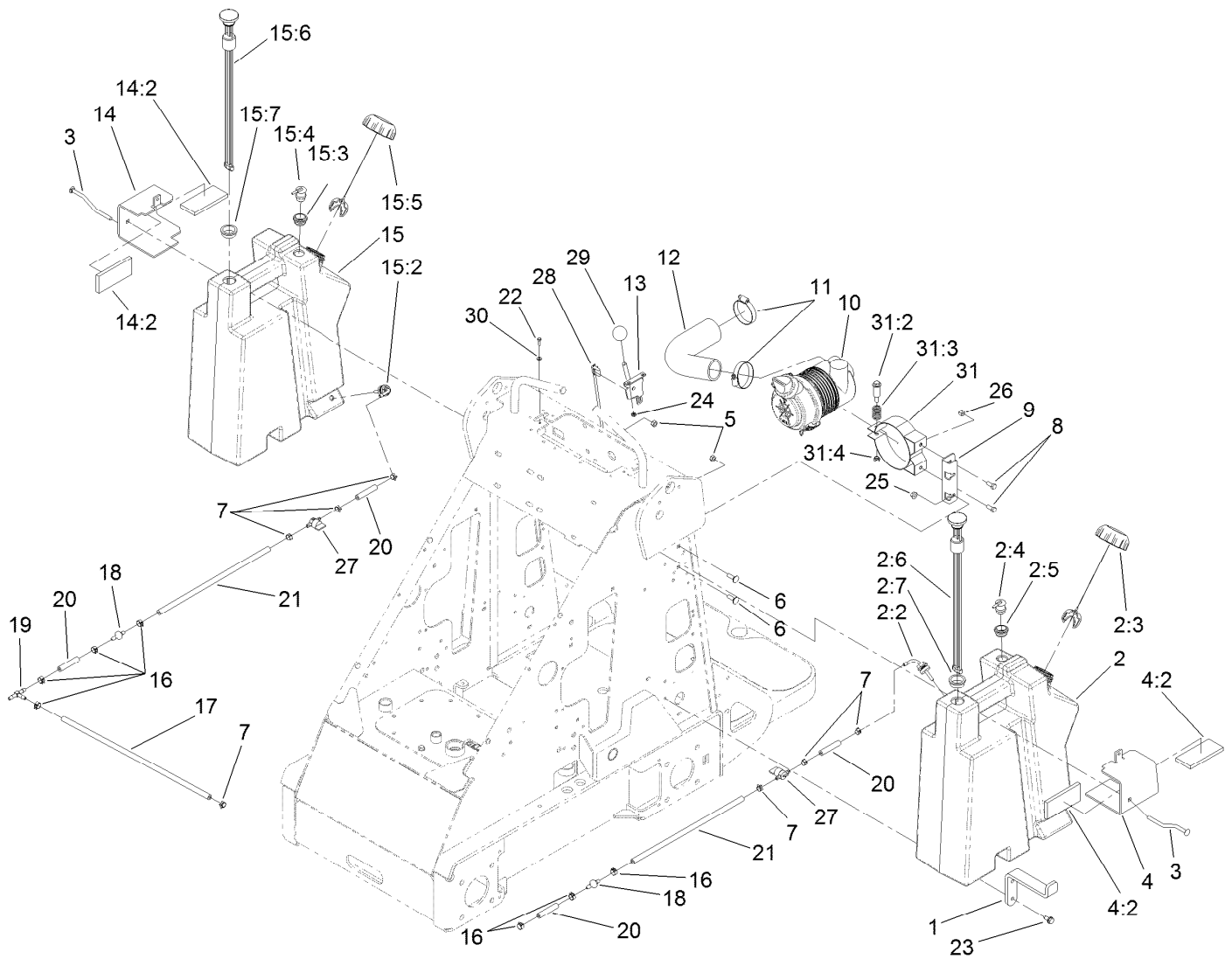

Fuel Tank and Air Filter Assembly (continued)

<i>Ref.</i>	<i>Part Number</i>	<i>Qty.</i>	<i>Description</i>	<i>Ref.</i>	<i>Part Number</i>	<i>Qty.</i>	<i>Description</i>
29	233-42	2	Knob	31:2	94-3653	1	Bolt
30	3256-51	4	Washer-Flat	31:3	94-3654	1	Spring
31	93-2191	1	Band-Mounting, Air Cleaner	31:4	48-9510	1	Nut

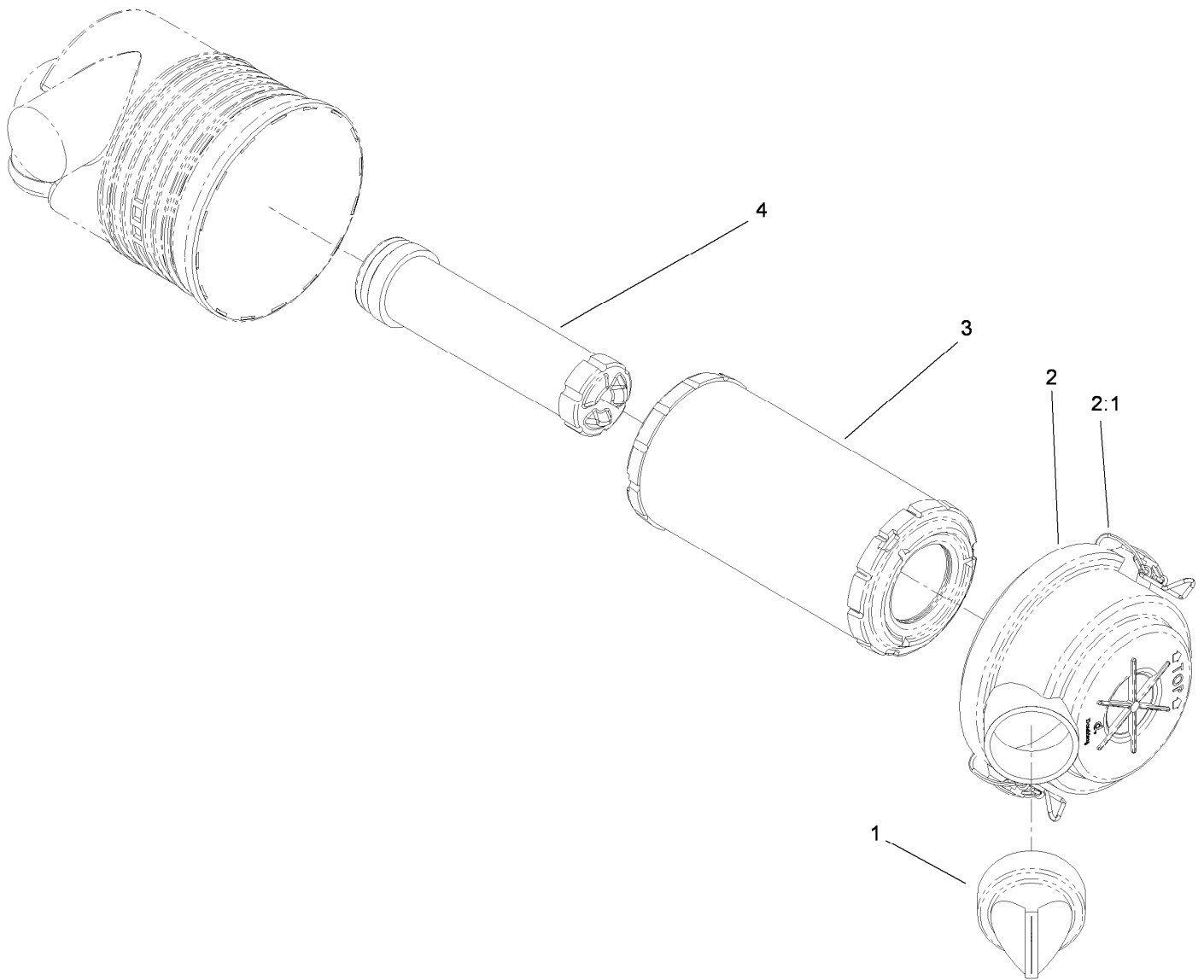

Air Cleaner Assembly No. 117-9989

<i>Ref.</i>	<i>Part Number</i>	<i>Qty.</i>	<i>Description</i>
1	87-9400	1	Valve-Vacuator
2	94-3652	1	Cover ASM
2:1	1-643283	2	Latch-Cleaner, Air
3	108-3811	1	Filter-Air
4	98-2982	1	Filter-Element, Safety

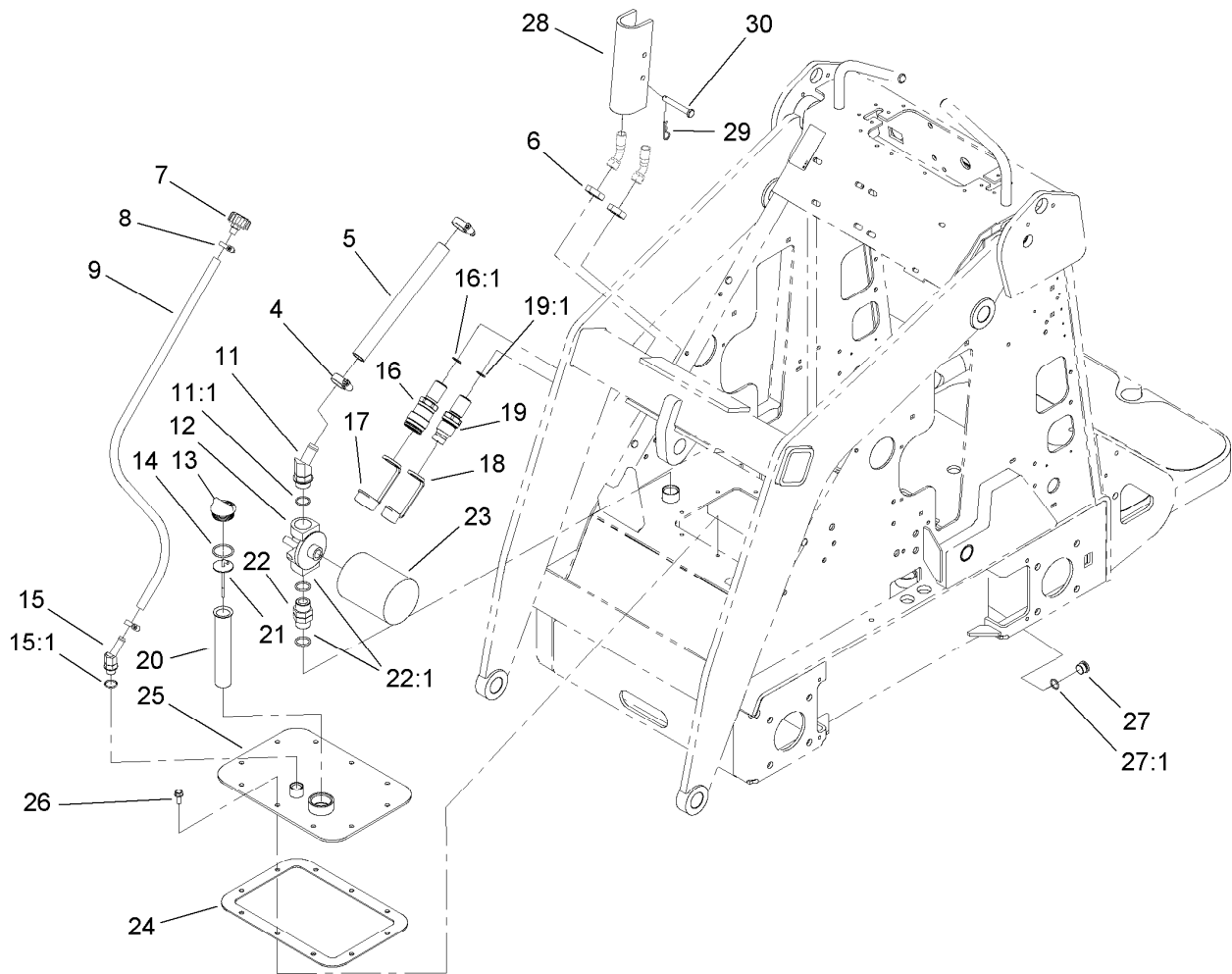

Hydraulic Tank and Filter Assembly

Ref.	Part Number	Qty.	Description	Ref.	Part Number	Qty.	Description
4	2412-129	2	Clamp-Hose	19	105-8395	1	Bulkhead Nipple ASM
5	98-4745	1	Hose-HYD, Suction, Hi	19:1	237-65	1	O-Ring
6	340-74	2	Nut-Lock, Bulkhead	19:2	100-6120	1	Seal Kit ●
7	68-6150	1	Breather	20	61-2790	1	Filter-Screen
8	2412-36	2	Clamp-Hose	21	100-2097	1	Dipstick-Oil
9	98-2708	1	Hose-Vent	22	98-9906	1	Fitting-Thread, Straight
11	354-127	1	Elbow-45 DEG	22:1	237-81	2	O-Ring
11:1	237-81	1	O-Ring	23	54-0110	1	Filter-Oil, Transmission
12	92-5821	1	Filter Head ASM	24	98-9927	1	Gasket-Cover
13	93-7498	1	Plug-Plastic	25	100-1713-01	1	Cover ASM
14	237-123	1	O-Ring	26	98-9940	10	Screw
15	354-126	1	Fitting-HYD, 45 DEG	27	353-988	1	Plug-Hex
15:1	237-79	1	O-Ring	27:1	237-79	1	O-Ring
16	105-8394	1	Bulkhead Coupler ASM	28	98-4675-01	2	Lock-Cylinder
16:1	237-65	1	O-Ring	29	3290-467	2	Pin-Hair
17	100-8816	1	Cap-Dust, Coupler	30	283-52	2	Pin-Clevis
18	100-8815	1	Cap-Dust, Nipple				

● Not illustrated

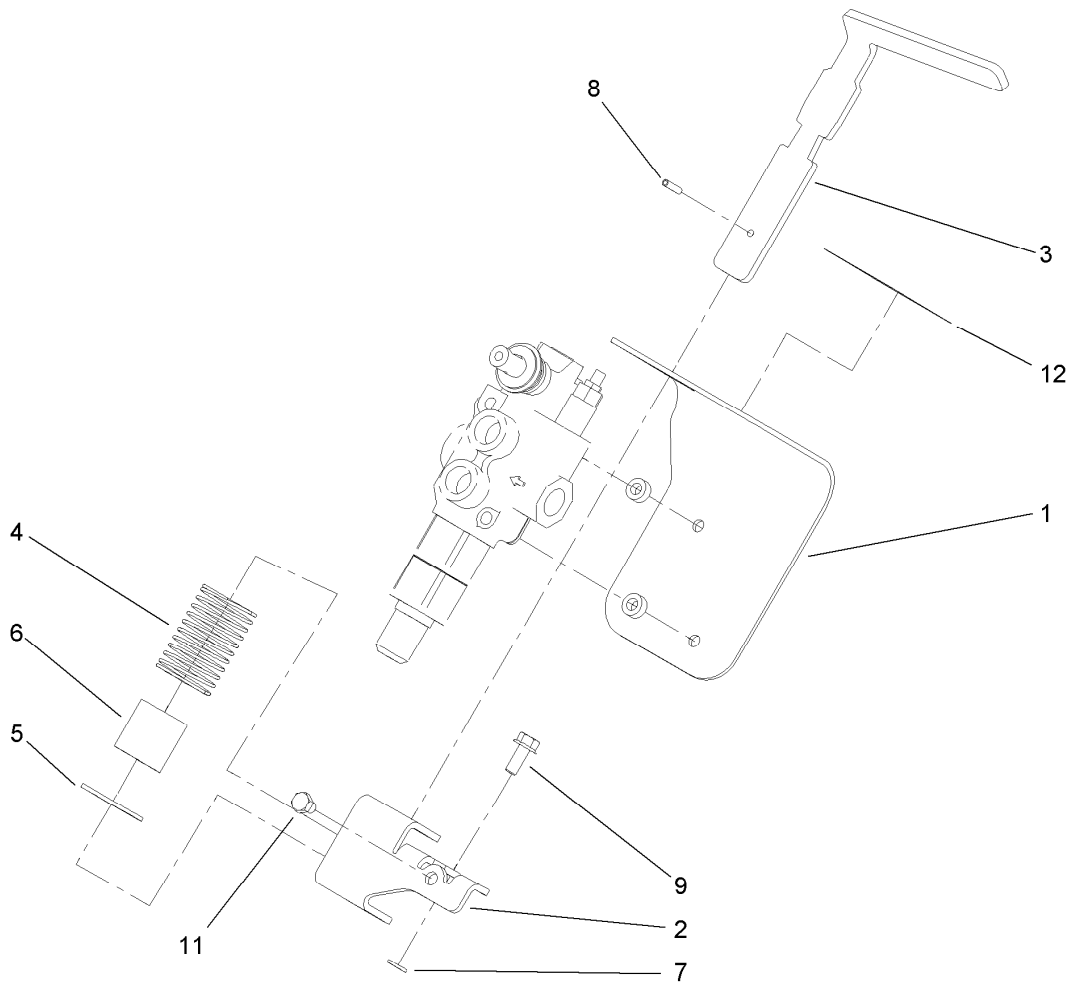

Auxiliary Control Lever Assembly

<i>Ref.</i>	<i>Part Number</i>	<i>Qty.</i>	<i>Description</i>
1	110-0121-03	1	Bracket-Auxiliary
2	114-1263-03	1	Mount-Lever, Aux
3	110-0123	1	Handle-Lever, Auxiliary
4	110-0124	1	Spring
5	110-0125	1	Retainer-Spring, Auxiliary
6	110-0160	1	Tube-Spring
7	3253-4	1	Washer-Lock
8	32121-3	1	Pin-Spring
9	33104-020	1	Screw-HHF
11	33114-010	1	Screw-HH
12	108-4733	1	Decal-Auxiliary

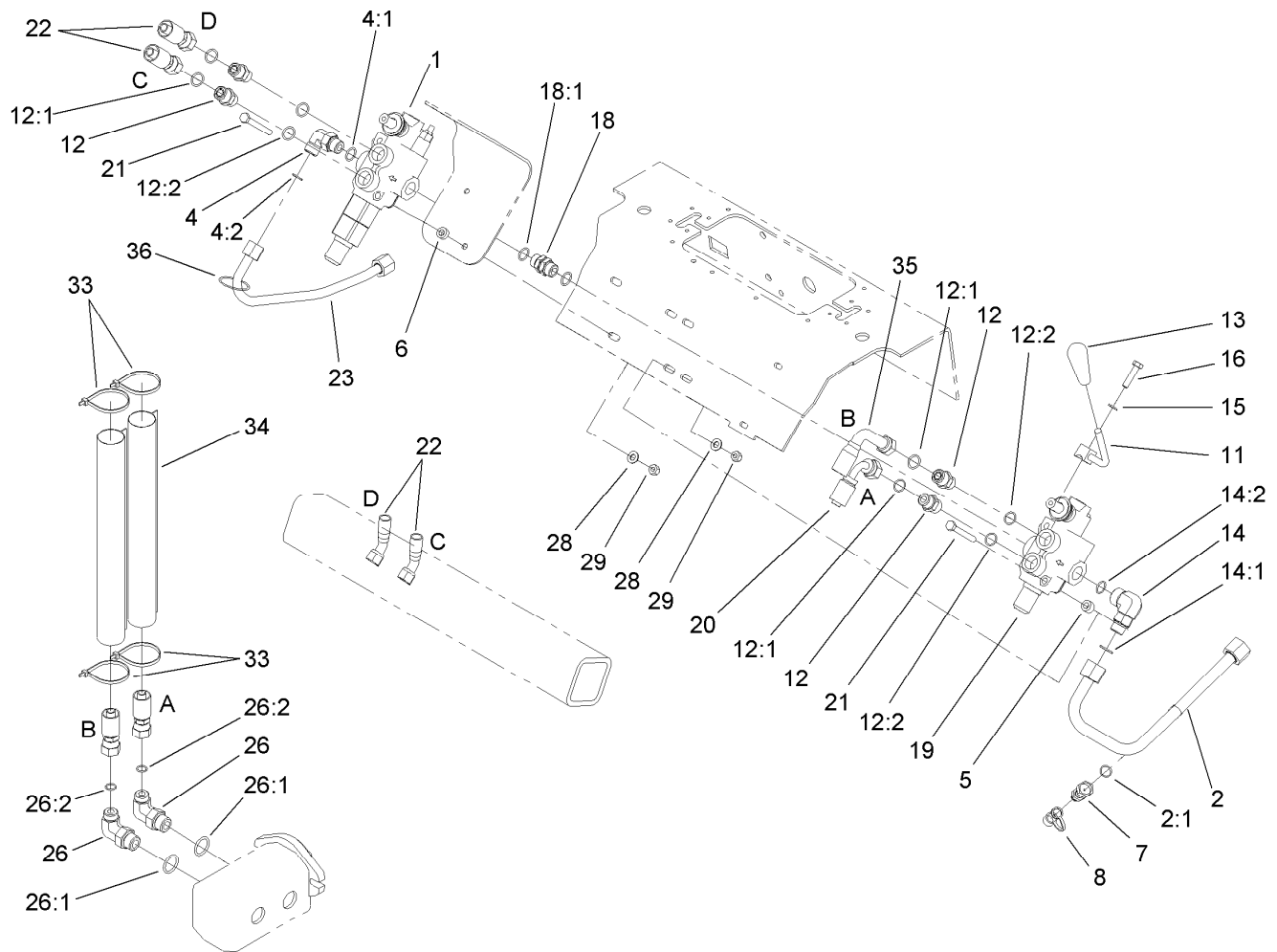

Hydraulic Valve Assembly

Ref.	Part Number	Qty.	Description
1	99-3077	1	HYD Auxiliary Valve ASM
2	108-4716	1	HYD Tube ASM
2:1	237-22	1	O-Ring
4	340-98	1	Fitting-HYD, 90 DEG
4:1	237-79	1	O-Ring
4:2	237-30	1	O-Ring
5	98-4695	2	Spacer
6	100-2085	2	Spacer
7	86-5480	1	Nipple-Test
8	354-79	1	Cap-Dust
11	108-9709-03	1	Lever-Control
12	340-4	4	Fitting-HYD, Straight
12:1	237-30	1	O-Ring
12:2	237-79	1	O-Ring
13	98-0152	1	Knob-Tapered
14	340-153	1	Fitting-Elbow, 90 DEG
14:1	237-79	1	O-Ring
14:2	237-151	1	O-Ring

Ref.	Part Number	Qty.	Description
15	3253-4	1	Washer-Lock
16	33114-035	1	Screw-HH
18	95-3209	1	Fitting-Thread, Straight
18:1	237-79	2	O-Ring
19	99-3072	1	HYD Selector Valve ASM
20	98-4747	1	HYD Hose ASM
21	322-12	4	Screw-HH
22	100-8817	2	HYD Hose ASM
23	105-7879	1	Tube-HYD
26	340-105	2	Fitting-HYD, 90 DEG
26:1	237-80	1	O-Ring
26:2	237-30	1	O-Ring
28	3256-23	4	Washer-Flat
29	3296-29	4	Nut-Lock, NI
33	3290-379	4	Tie-Cable
34	108-9715	2	Sleeve-Thermal
35	99-3008	1	HYD Hose ASM
36	3290-379	8	Tie-Cable

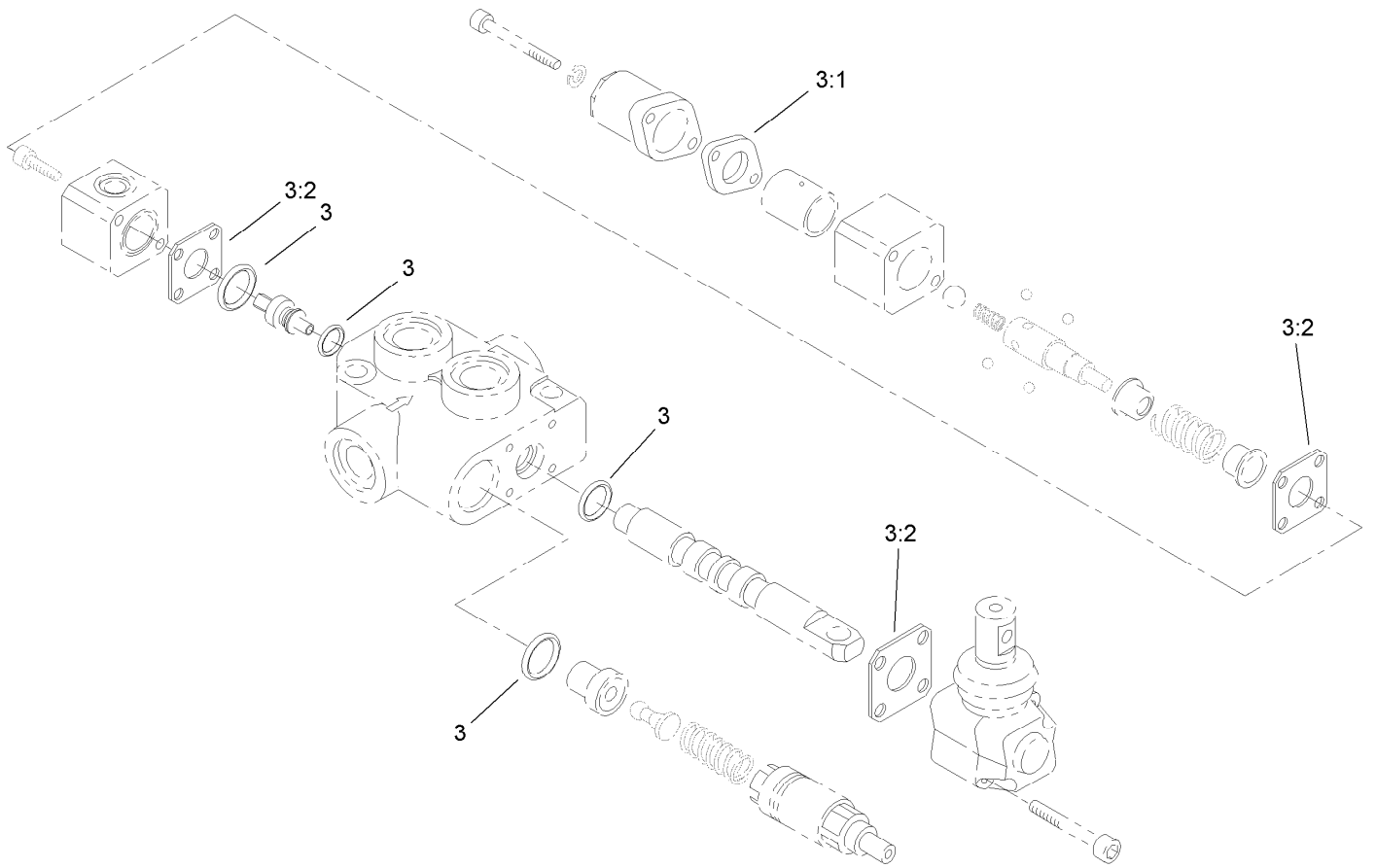

Auxiliary Hydraulic Valve Assembly No. 99-3077

<i>Ref.</i>	<i>Part Number</i>	<i>Qty.</i>	<i>Description</i>
3	99-4391	1	Seal Kit
3:1	99-3074	1	Gasket
3:2	99-3075	3	Gasket

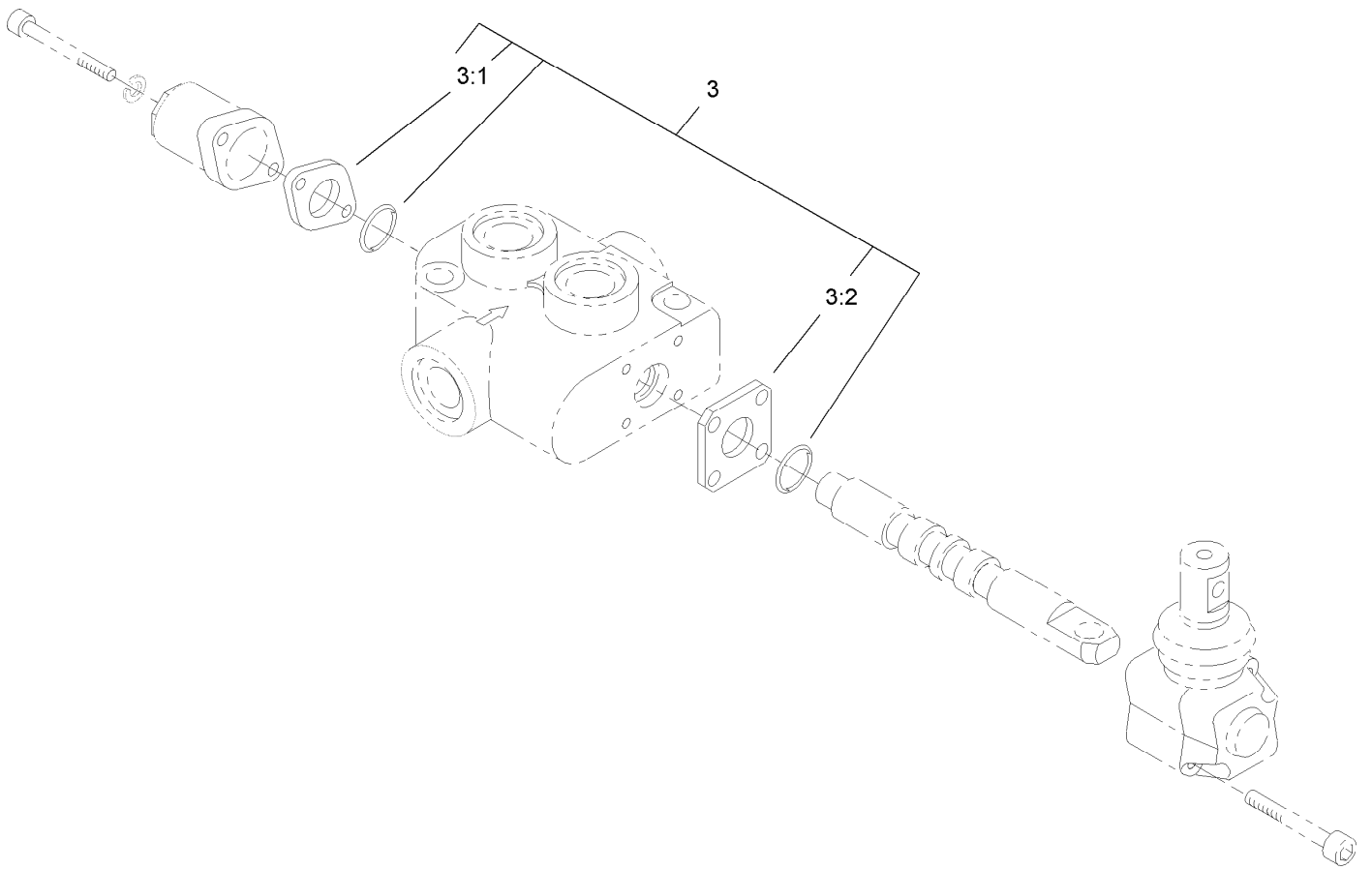

Hydraulic Selector Valve Assembly No. 99-3072

<i>Ref.</i>	<i>Part Number</i>	<i>Qty.</i>	<i>Description</i>
3	99-4391	1	Seal Kit
3:1	99-3074	1	Gasket
3:2	99-3075	3	Gasket

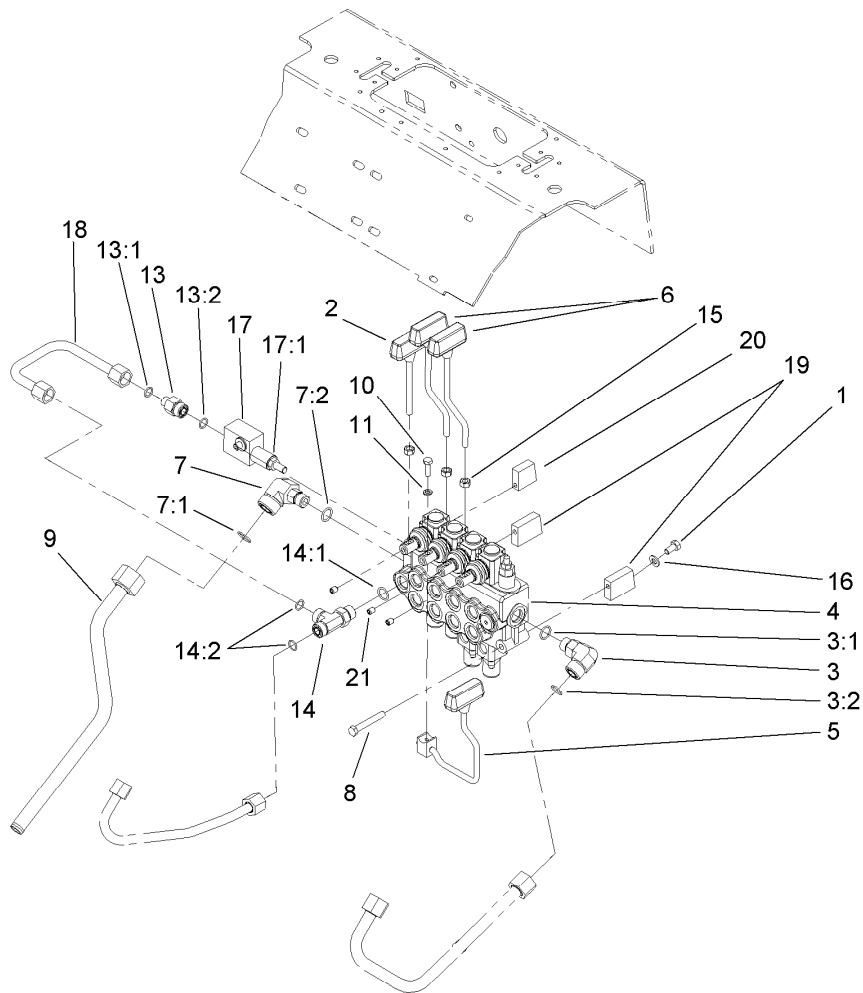

Four Spool Valve Assembly

<i>Ref.</i>	<i>Part Number</i>	<i>Qty.</i>	<i>Description</i>	<i>Ref.</i>	<i>Part Number</i>	<i>Qty.</i>	<i>Description</i>
1	322-2	3	Screw-HH	13	340-5	1	Fitting-Straight
2	105-7881	1	Cylinder Lever ASM	13:1	237-42	1	O-Ring
3	340-153	1	Fitting-Elbow, 90 DEG	13:2	237-30	1	O-Ring
3:1	237-79	1	O-Ring	14	340-109	1	Fitting-HYD, Tee
3:2	237-151	1	O-Ring	14:1	237-79	1	O-Ring
4	105-8377	1	HYD Four Spool Valve ASM	14:2	237-30	2	O-Ring
5	106-8165	1	Control Lever ASM	15	33014-00	3	Nut-Hex
6	104-5733	2	Drive Lever ASM	16	33094-00	3	Washer-Plain
7	92-5696	1	Fitting-HYD, 90 DEG	17	105-7882	1	Relief Valve ASM
7:1	237-58	1	O-Ring	17:1	105-8358	1	Cartridge-Valve, Relief
7:2	237-79	1	O-Ring	17:2	105-8357	1	Seal Kit ●
8	322-11	3	Screw-HH	18	108-4717	1	HYD Tube ASM
9	106-8177	1	Tube-Tank, HYD	19	108-4728	2	Spacer
10	321-5	1	Screw-HH	20	105-7870	1	Spacer-Upper
11	3253-3	1	Washer-Lock	21	105-4068	3	Screw-Set, HSH

● Not illustrated

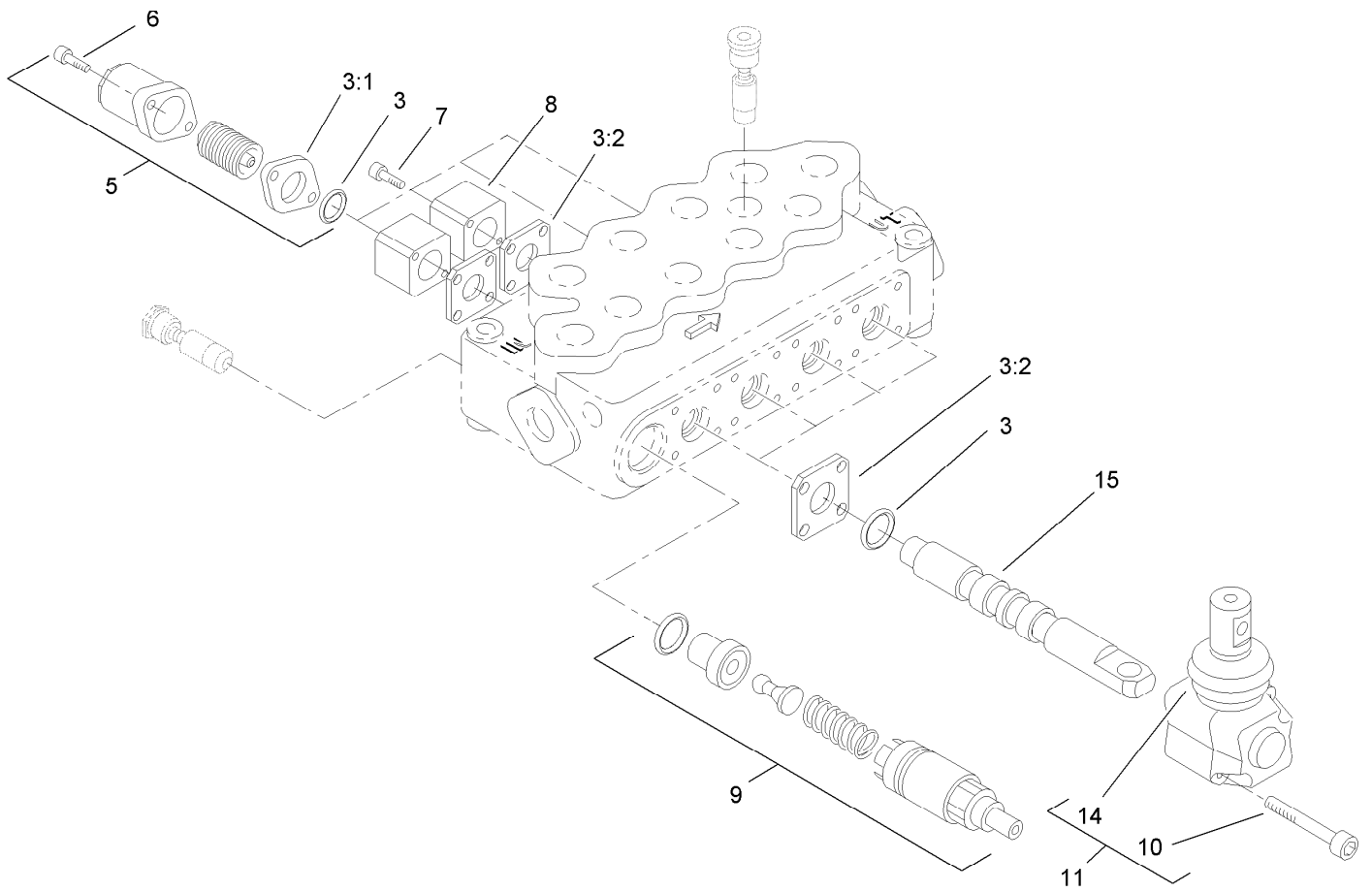

Four Spool Valve Assembly No. 105-8377

<i>Ref.</i>	<i>Part Number</i>	<i>Qty.</i>	<i>Description</i>
3	99-4390	1	Seal Kit
3:1	99-3074	4	Gasket
3:2	99-3075	8	Gasket
5	100-8800	4	Standard Spring ASM
5	100-8801	4	High Force Spring Kit
6	100-8802	8	Screw-Cap, End
7	100-8803	4	Screw
8	100-8804	2	Block-Mount, Switch
9	100-8805	1	Valve-Relief
10	100-8806	8	Screw
11	100-8807	4	Operator ASM
14	100-8829	4	Boot
15	105-8441	4	Spool-Valve

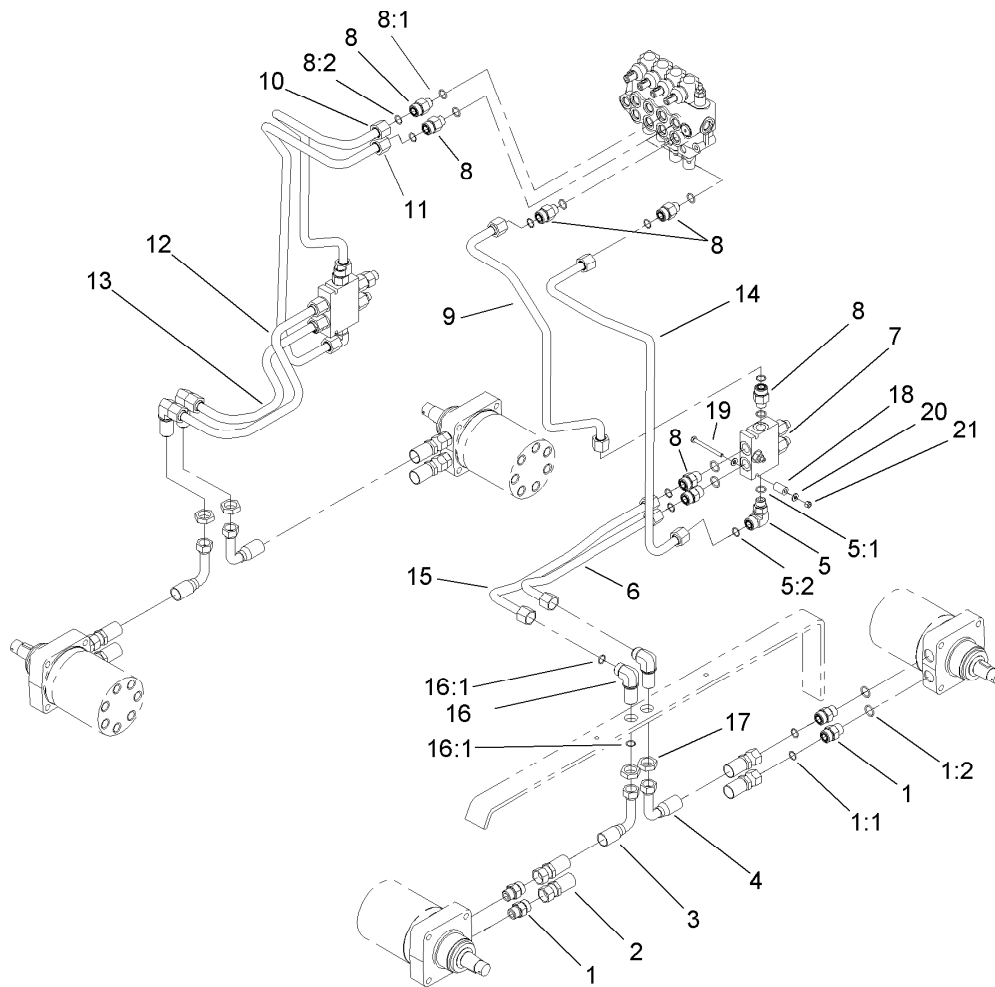

Hydraulic Motor Assembly

<i>Ref.</i>	<i>Part Number</i>	<i>Qty.</i>	<i>Description</i>	<i>Ref.</i>	<i>Part Number</i>	<i>Qty.</i>	<i>Description</i>
1	340-7	8	Adapter	9	108-9729	1	HYD Tube ASM
1:1	237-65	1	O-Ring	10	108-9727	1	HYD Tube ASM
1:2	237-80	1	O-Ring	11	108-9726	1	HYD Tube ASM
2	99-3012	2	HYD Hose ASM	12	99-3025	1	HYD Tube ASM
3	99-3010	2	HYD Hose ASM	13	99-3028	1	HYD Tube ASM
4	99-3011	2	HYD Hose ASM	14	108-9725	1	HYD Tube ASM
5	340-153	2	Fitting-Elbow, 90 DEG	15	99-3026	1	HYD Tube ASM
5:1	237-79	1	O-Ring	16	340-72	4	Fitting-Bulkhead, 90 DEG
5:2	237-151	1	O-Ring	16:1	237-65	2	O-Ring
6	99-3022	1	HYD Tube ASM	17	340-74	4	Nut-Lock, Bulkhead
7	99-3040	2	HYD Counterbalance Valve ASM	18	99-3057	2	Spacer-Valve
8	340-155	10	Fitting-HYD, Straight	19	321-23	2	Screw-HH
8:1	237-79	1	O-Ring	20	3256-22	4	Washer-Flat
8:2	237-151	1	O-Ring	21	3296-42	2	Nut-Lock, NI

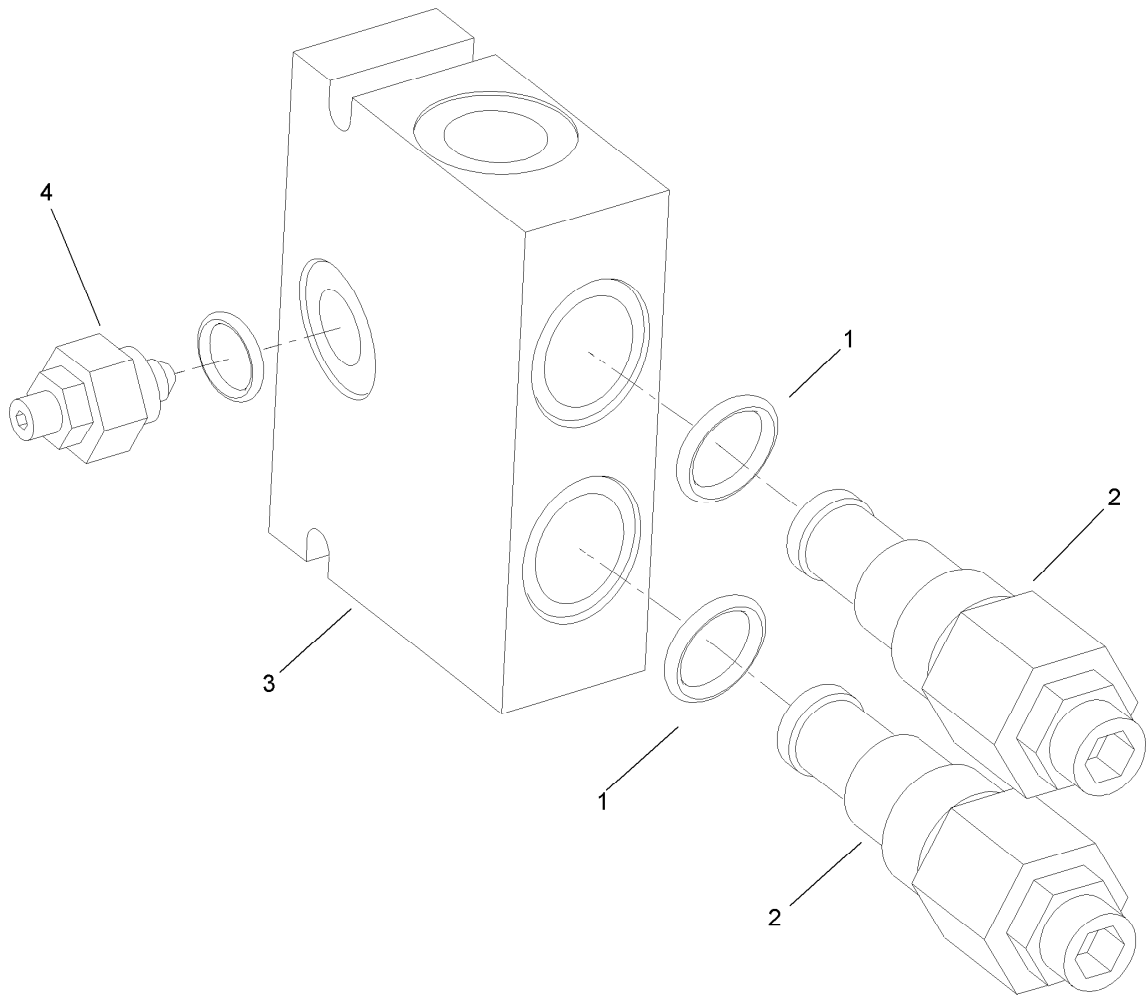

Counterbalance Valve Assembly No. 99-3040

<i>Ref.</i>	<i>Part Number</i>	<i>Qty.</i>	<i>Description</i>
1	105-4099	1	Seal Kit ●
2	99-3271	2	Valve-Cartridge
3	100-8864	1	Manifold ASM
4	100-8865	1	Needle Valve ASM

● Not illustrated

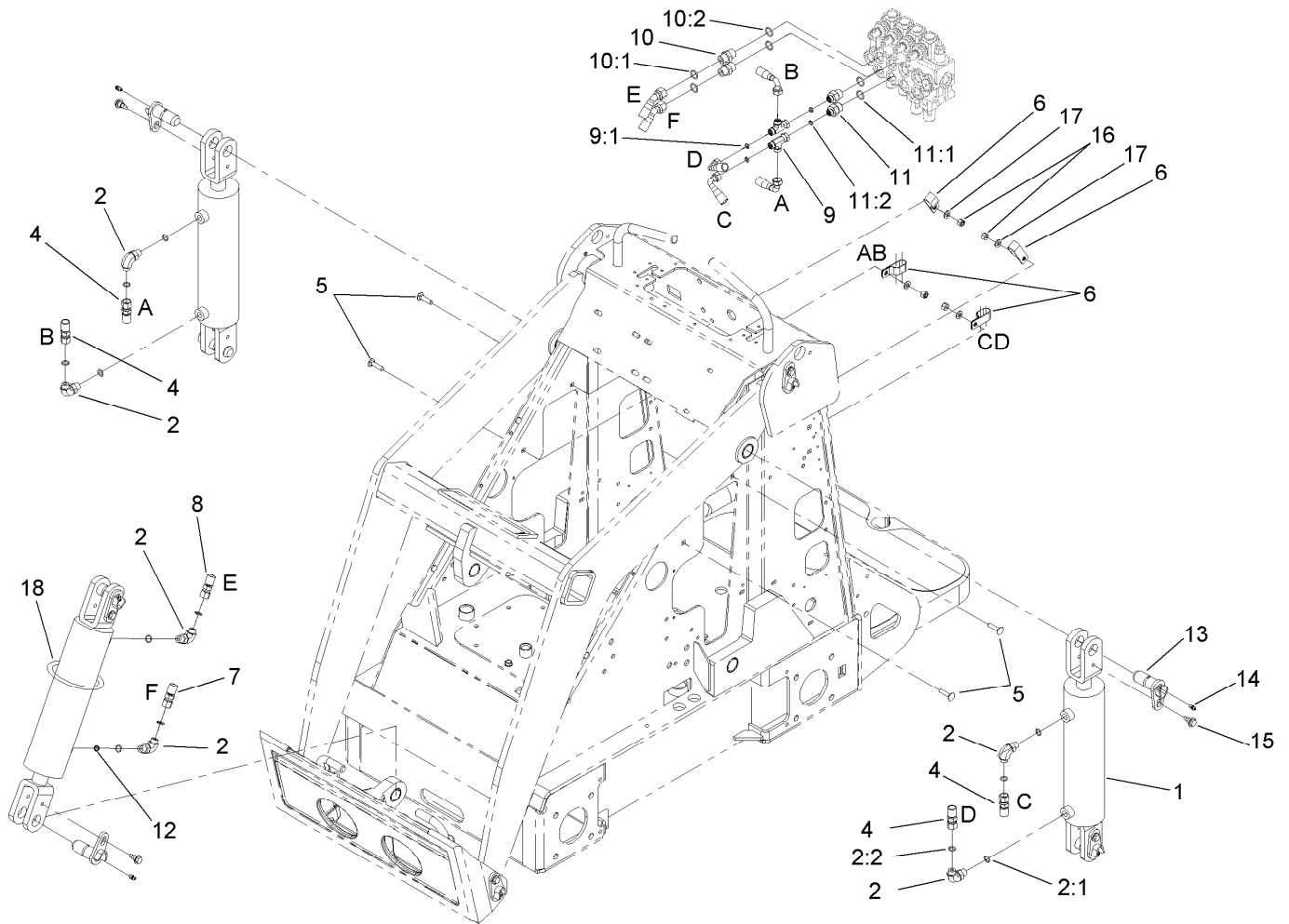

Hydraulic Cylinder Assembly

Ref.	Part Number	Qty.	Description
1	105-7867	3	HYD Cylinder ASM
2	340-82	6	Adapter
2:1	237-42	1	O-Ring
2:2	237-21	1	O-Ring
4	98-4725	4	Hose-HYD
5	3230-3	4	Screw-CARR
6	2412-137	4	Clamp-R, Double
7	98-4726	1	Hose-HYD
8	98-4727	1	Hose-HYD
9	340-151	2	Fitting
9:1	237-75	3	O-Ring
10	340-3	2	Adapter
10:1	237-22	1	O-Ring
10:2	237-79	1	O-Ring
11	340-133	2	Adapter
11:1	237-79	1	O-Ring
11:2	237-21	1	O-Ring
12	108-4714	1	Orifice-Port Insert, One Way
13	112-2609	6	Pivot Pin ASM
14	302-5	6	Fitting-Grease
15	99-5105	6	Bolt-Shoulder
16	3296-29	4	Nut-Lock, NI
17	3256-23	4	Washer-Flat
18	3334-945	1	Tie-Cable

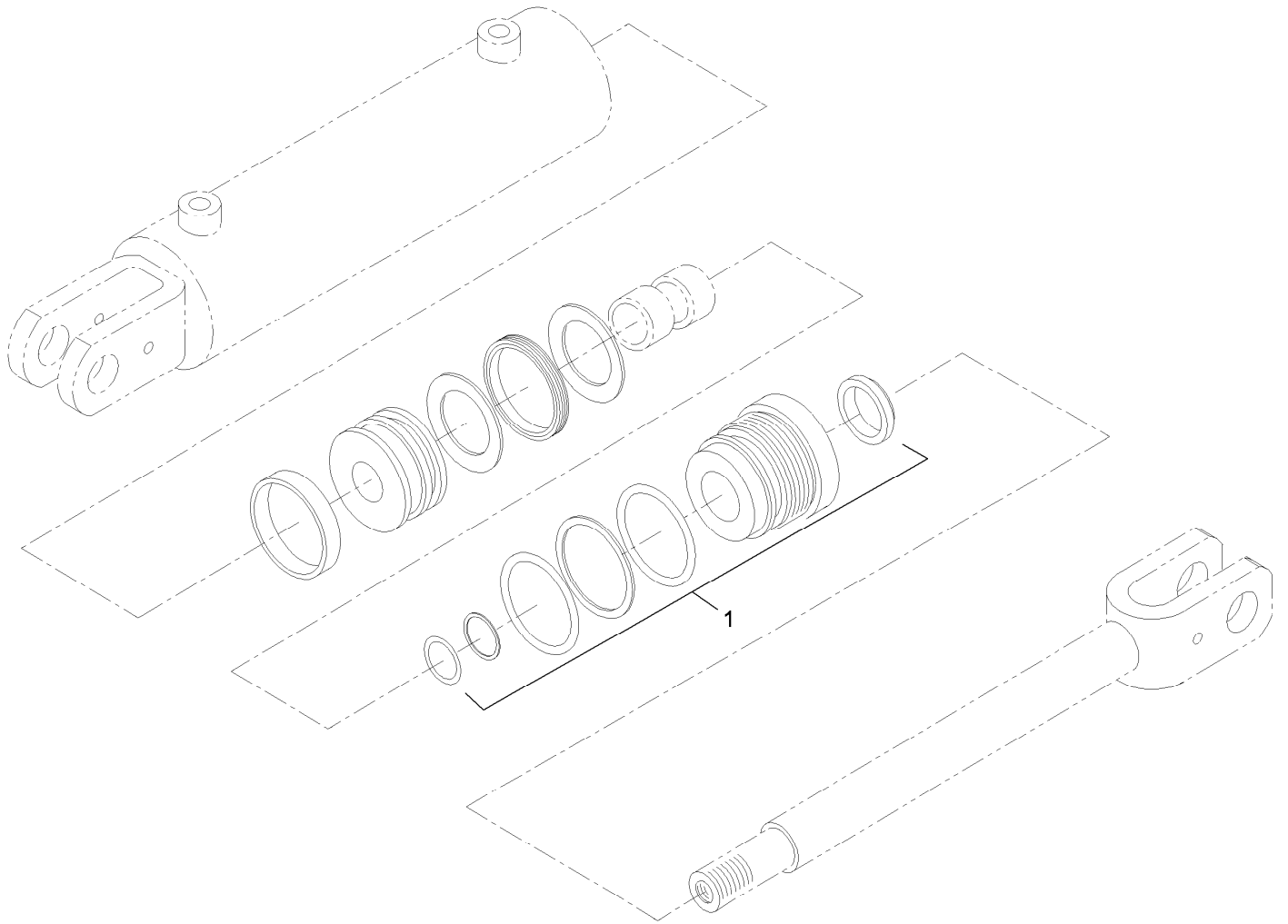

Hydraulic Cylinder Assembly No. 105-7867

<i>Ref.</i>	<i>Part Number</i>	<i>Qty.</i>	<i>Description</i>
1	105-8356	1	Seal Kit

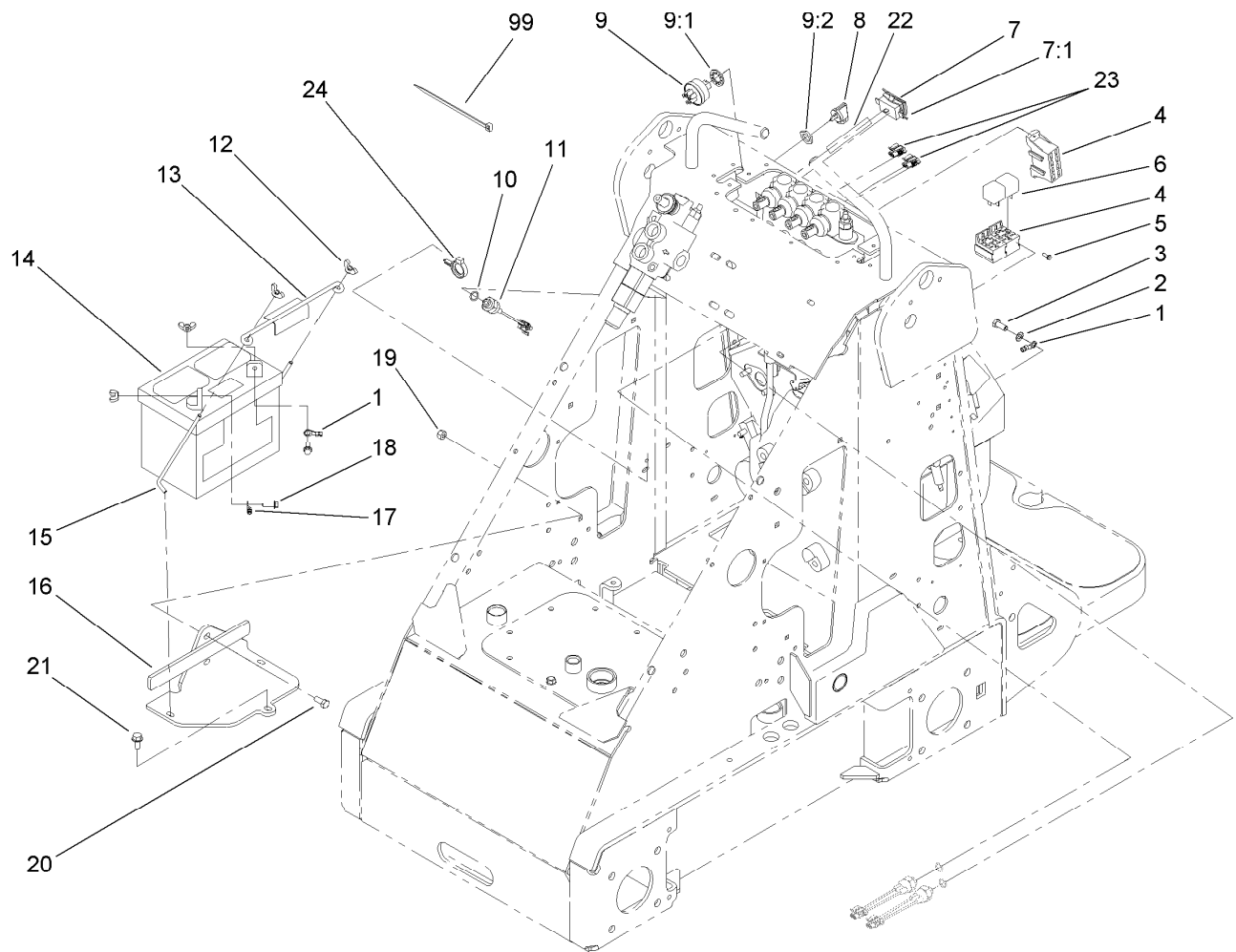

Electrical Component Assembly

<i>Ref.</i>	<i>Part Number</i>	<i>Qty.</i>	<i>Description</i>	<i>Ref.</i>	<i>Part Number</i>	<i>Qty.</i>	<i>Description</i>
1	111075	1	Wire ASM	12	32103-22	4	Nut-Wing
2	3255-8	1	Washer-Lock	13	113010	1	Holddown-Battery
3	33114-020	1	Screw-HH	14	104-2492	1	Battery
4	104-7411	1	Harness-Wire	15	99-5027	2	Retainer-Battery
5	32144-87	3	Screw-HWHTF	16	99-3060-03	1	Battery Mount ASM
6	98-7249	2	Relay	17	100-1712	1	Cable-Positive
7	105-4067	1	Hourmeter-Inductive	18	3234-4	2	Screw-HHF
7:1	104-4234	1	Clip-Mounting	19	3296-29	2	Nut-Lock, NI
8	63-8360	2	Key-Ignition	20	322-4	2	Screw-HH
9	111216	1	Ignition Switch ASM	21	32144-70	1	Screw-HWHTF
9:1	9201604	1	Washer-Lock	22	104-7408	1	Wire-Hourmeter
9:2	101884	1	Nut	23	99-1433	2	Connector-Female
10	237-42	3	O-Ring	24	105-1853	1	Clamp-Hose
11	72-4310	3	Switch-Ball	99	3290-381	5	Tie-Cable

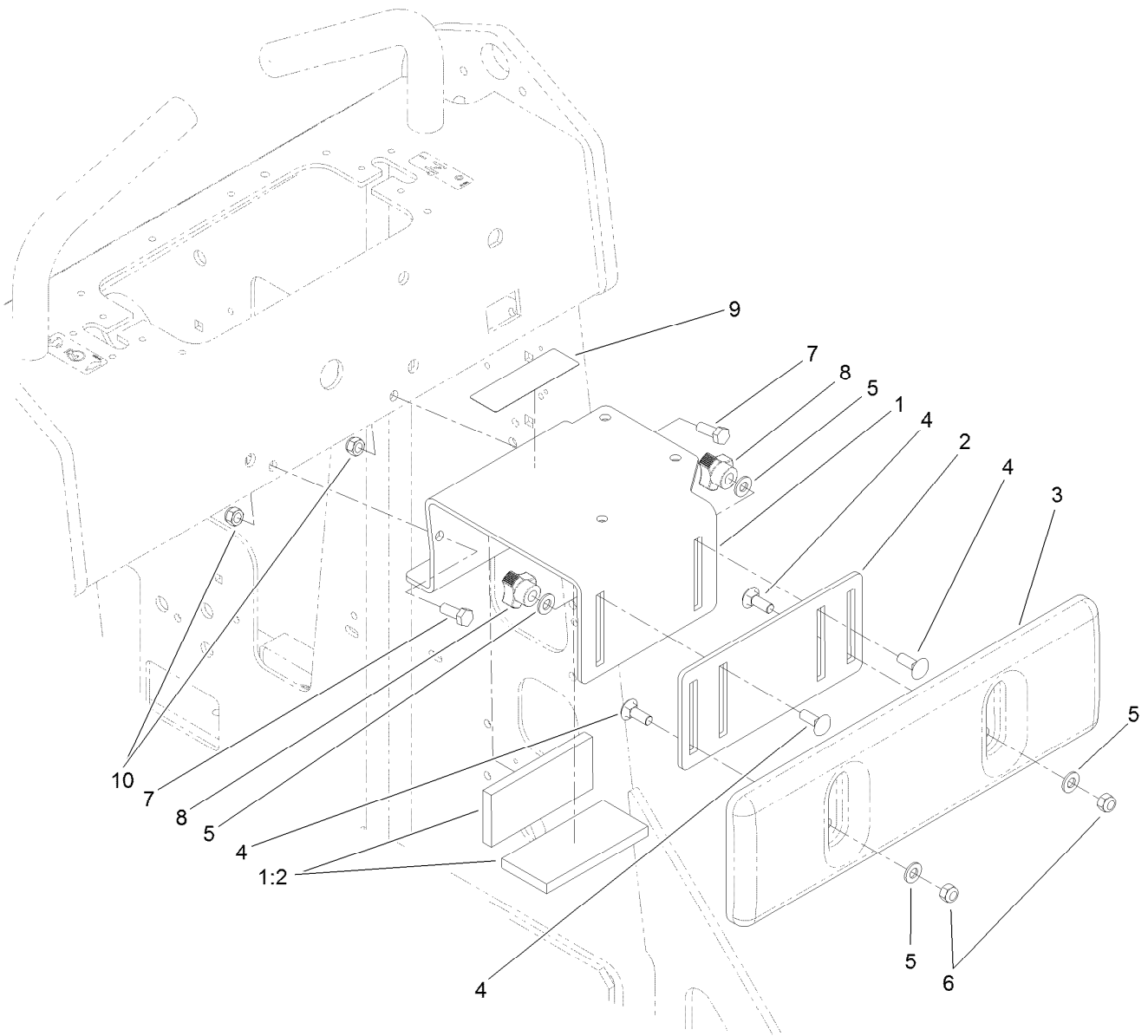

Thigh Support Assembly

Ref.	Part Number	Qty.	Description
1	117-1803	1	Thigh Support Bracket ASM
1:2	117-1798	2	Pad-Foam
2	105-0337-03	1	Plate-Adjusting
3	105-0333	1	Support-Thigh
4	3230-16	4	Screw-CARR
5	3256-70	4	Washer-Flat
6	3296-72	2	Nut-Lock, NI
7	322-4	2	Screw-HH
8	104-6156	2	Knob-Adjustment
9	104-6108	1	Decal-Manual
10	32128-20	2	Nut-HF

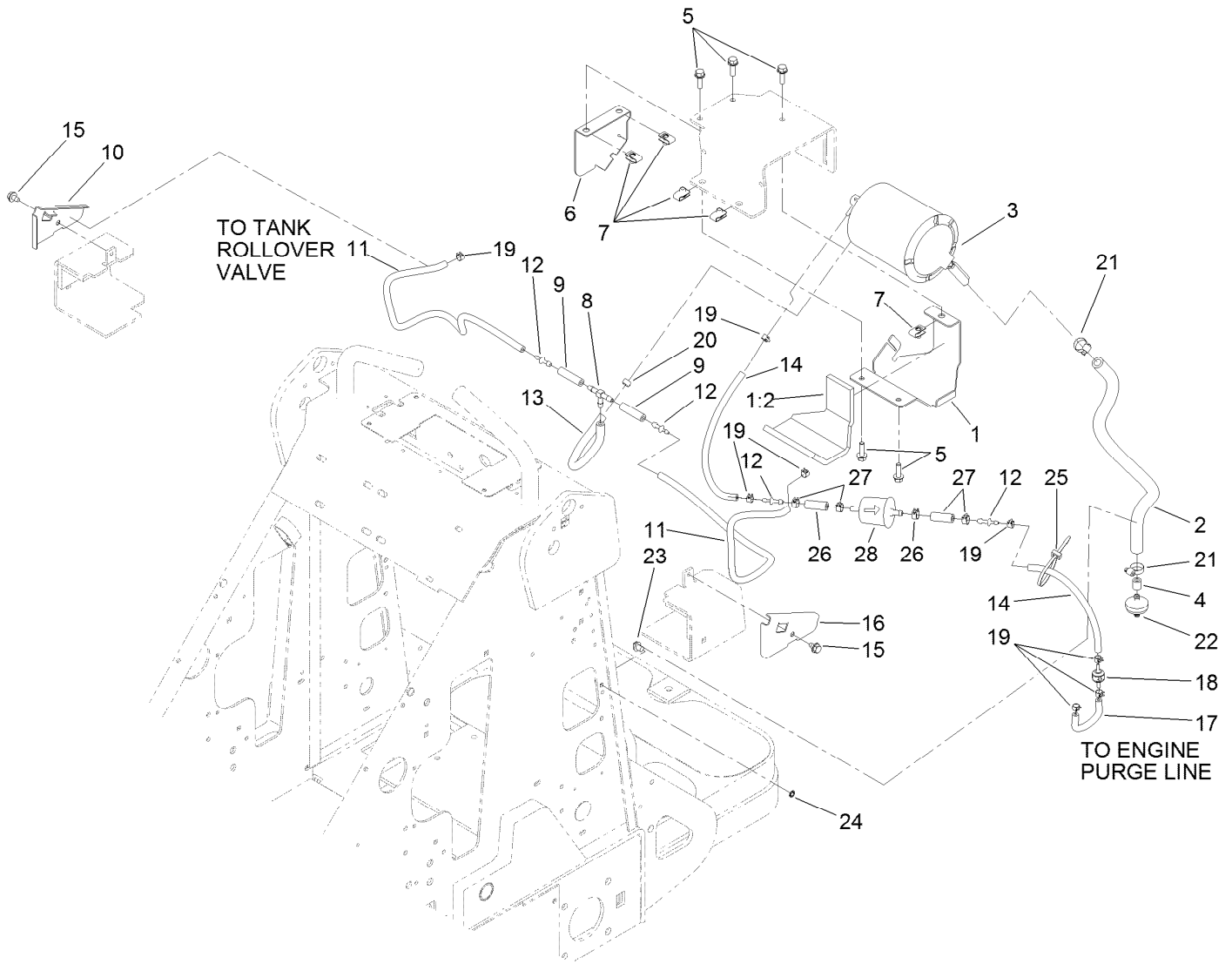

Fuel Tank Vent Assembly

Ref.	Part Number	Qty.	Description	Ref.	Part Number	Qty.	Description
1	117-1800	1	Canister Mount ASM	15	9266934	2	Screw
1:2	117-1799	1	Pad-Foam	16	117-1791-03	1	Plate-Hose Retainer L.H.
2	106-5709	1	Hose-Vent	17	115-4736	1	Hose-Fuel
3	116-1442	1	Canister-Carbon, 1200Cc	18	115-7868	1	Valve-Check, Vacuum
4	117-1789	1	Hose-Fuel	19	2412-146	8	Clamp-Hose
5	3234-29	5	Screw-HHF	20	2412-98	1	Clamp-Hose
6	117-1785-03	1	Cover-Canister	21	2412-36	2	Clamp-Hose
7	115-7721	5	Nut-Clip, U	22	115-7854	1	Filter-Fuel, Inline
8	99-5005	1	Fitting-Tee, Barbed	23	32180-030	1	Clip-Harness
9	99-9415	2	Hose-Fuel	24	3254-8	1	Washer-Lock
10	117-1792-03	1	Plate-Hose Retainer, RH	25	3290-378	1	Tie-Cable
11	119-6074	2	Hose-Fuel	26	106-5317	2	Hose-Fuel
12	106-8150	4	Fitting-Straight	27	92-2379	4	Clamp-Hose
13	109-0294	1	Hose-Fuel	28	120-2235	1	Filter-Air
14	51-3217	2	Hose-Fuel				

Attachments and Accessories

For 22318 323 Compact Utility Loader

Product Name	Model/Part
Tire Chain Kit	100-4140
Helmet-Face Shield	100-4143
Light Kit.....	100-8940
Narrow Tire ASM	104-0572
Tube-Tire (18 x 8.50-10)	105-4070
Rubber Foot Mat.....	105-5805
Tube-Tire (18 X 8.50-8).....	106396
CE Conversion Kit	22366
4 Cubic Foot Standard Bucket	22409
Loose Materials Bucket	22410
48in Hydraulic Blade	22414
Rotary Broom	22415
Counterweight	22417
Bore Drive Head	22420
Rod And Reamer	22421
Multi-Purpose Tool	22423
Power Box Rake	22425
Stump Grinder	22429
Tree Forks	22438
Cement Bowl	22442
The Eliminator Scarifier/Groomer	22443
40in Tiller	22445
Snowthrower.....	22456
Trencher Head.....	22470
High-Speed Trencher Head	22471
Narrow Bucket	22520
Over-the-Tire Rubber Tracks	22662
Auger Head	22802
Universal Swivel Auger Head	22803
Vibratory Plow	22911
Soil Cultivator	23101
Seeder Box Kit, Soil Cultivator	23120
Concrete Breaker	23135
Backhoe.....	23163
Adjustable Forks.....	23164
Leveler.....	23165
Tube	232-37
LH Wheel And Tire ASM	98-2747
Wheel and Tire ASM.....	98-4709
Spark Arrestor	98-9099
RH Wheel And Tire ASM	99-1447
RH Wheel And Tire ASM (Powerlug)	99-3140
LH Wheel And Tire ASM (Powerlug).....	99-3141
Hydraulic Relief Valve Kit.....	99-4360

Notes:

Notes:

Notes:



Count on it.