

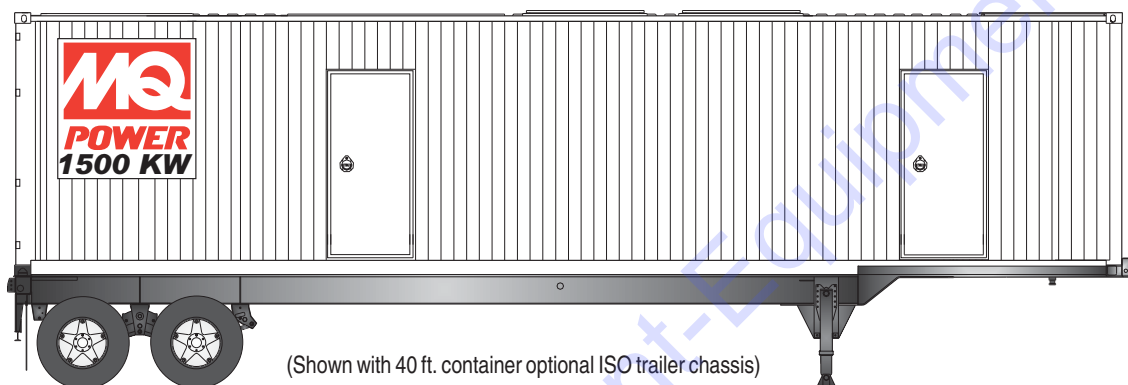

1500 kW Containerized Diesel Generator Set

Model	Emissions	Standby Rating	Prime Rating
EGC1500C	EPA Certified	60 Hz	
		1500kW (1875kVA)	1250kW (1562kVA)



Standard Features

Cummins Heavy Duty Diesel Engine

- 4-cycle design, turbocharged, aftercooled, direct injection
- Polymide blade cooling fan
- Engine coolant heater
- Meets Tier 2 EPA emissions standards

Fuel System

- 1000 gallon, single wall fuel tank
- Electric fuel priming system
- Fuel/water separators & drip pan
- Electric fuel run pump
- External fuel fill
- 30 micron RACOR® fuel/water separator with drip pan assembly

Alternator

- Brushless, 4-pole, synchronous, WYE connection
- Class H insulation system conforms to NEMA MG1-22, BS5000, CSA-C22-2, IEC-34-1 standards for temperature rise
- Separate excitation for fast recovery from block loads and motor starting
- Drip-proof, self-venting, amortisseur windings
- Epoxy impregnated windings with tropical insulation for increased environmental protection and long life

Automatic Voltage Regulator

- Circuitry senses true RMS voltage rather than average for superior load regulation

Full Load Acceptance

- Accepts 100% of standby nameplate rating in one step, in compliance with NFPA110 Standards

Generator Control Panel

- BASLER™ vibration-isolated controller
- Manual or remote engine start/stop
- RS485/Modbus communication support
- Safety shutdowns
- Externally mounted emergency stop switch
- Generator mainline circuit breaker, electronically operated, UL listed

Specially Designed Container

- 40 ft. ISO container, sound-attenuated, foam-lined for extremely quiet operation
- Isolated operator control room
- Solidly mounted battery rack and cooling system
- Integral vibration isolators
- Exterior polyurethane coating system provides long life in extreme operating conditions
- Interior DC lights and timer switch
- Crankcase filtration system
- Critical grade silencer with heat blankets

Warranty

- Engine-generator sets are covered by an express written, one-year limited warranty

TO PURCHASE THIS PRODUCT PLEASE CONTACT US



**Equipment Financing and
Extended Warranties Available**



**Discount-Equipment.com is your online resource for
commercial and industrial quality parts and equipment sales.**

561-964-4949

visit us on line @ www.discount-equipment.com

Select an option below to find your Equipment

Search by Manufacturer

Search by Product Type

Request a Quote

We sell worldwide for the brands: Genie, Terex, JLG, MultiQuip, Mikasa, Essick, Whiteman, Mayco, Toro Stone, Diamond Products, Generac Magnum, Airman, Haulotte, Barreto, Power Blanket, Nifty Lift, Atlas Copco, Chicago Pneumatic, Allmand, Miller Curber, Skyjack, Lull, Skytrak, Tsurumi, Husquvarna Target, Stow, Wacker, Sakai, Mi-T-M, Sullair, Basic, Dynapac, MBW, Weber, Bartell, Bennar Newman, Haulotte, Ditch Runner, Menegotti, Morrison, Contec, Buddy, Crown, Edco, Wyco, Bomag, Laymor, EZ Trench, Bil-Jax, F.S. Curtis, Gehl Pavers, Heli, Honda, ICS/PowerGrit, IHI, Partner, Imer, Clipper, MMD, Koshin, Rice, CH&E, General Equipment, Amida, Coleman, NAC, Gradall, Square Shooter, Kent, Stanley, Tamco, Toku, Hatz, Kohler, Robin, Wisconsin, Northrock, Oztec, Toker TK, Rol-Air, APT, Wylie, Ingersoll Rand / Doosan, Innovatech, Con X, Ammann, Mecalac, Makinex, Smith Surface Prep, Small Line, Wanco, Yanmar



1500 kW Containerized Diesel Generator Set

Alternator Specifications	
Model 742RSL4050	Marathon Magna Max
Type	Rotating Field
Number of Leads	4 bar
Generator Type	Rotating Field; PMG
Voltage Regulator	Solid State, Digital, Model DVR2000
Insulation	NEMA MG1-1.66
Material	Class H
Temperature Rise	105° / 130° C
Bearing: Number, Type	Single Sealed
Coupling	Flexible Disk
Amortisseur Windings	Full
Voltage Regulation	0.25%
One Step Load Acceptance % of rating per NFPA-110	100
Peak Motor Starting HP	750
Generator Efficiency at Full Load	95%
Phase Sequence	ABC (L1, L2, L3)
L-L Harmonic Max Total	5.0%
L-L Harmonic Max Single	3.0%
Voltage Dip Upon Full Load Application (1 Step)	12.5% for 0.4 sec.
Voltage Rise Upon Full Load Rejection (1 Step)	17% for 0.7 sec.

The EGC1500C Sound Attenuated Generator is configured for standard 60 Hz, 480V output. Special voltage outputs are available (special order).

Alternator Features

- All ratings tested per MIL-STD-705 as applicable
- Protection for overload and short circuit
- Designed and built within NEMA, IEEE and ANSI standards for temperature rise
- PMG exciter for superior regulation and response
- Three-phase sensing on regulator
- Skewed rotor for smooth voltage wave form
- Optional-vacuum impregnated epoxy varnish, fungus resistant per MIL-I-24092
- Listed to UL1446 and UL1004B Standards

Engine Specifications	
EPA Family Name 8CEXL050.AAD	Cummins QSK50-G4
Engine Type	4-cycle, Turbocharged, Watercooled, Aftercooler
Cylinder Arrangement	V 16
Displacement	3067 cu in (50.3 L)
Bore	6.25 in. (159 mm)
Stroke	6.25 in. (159 mm)
Compression Ratio	14.9 : 1
Piston Speed (60Hz)	1875/sec
Bearing Main: Number	9
Bearing Main: Type	Replaceable, Precision
Cylinder Block	Cast iron with wet, replaceable cylinder liners
Cylinder Head Material	Cast iron
Crankshaft Material	Forged steel
Brake Mean Effective Pressure (BMEP)	318.0 psi (2192.5 kPa)
Rated RPM (60Hz)	1800 RPM
Max. Power At Rated RPM (with fan)	2250 hp (1703 kW)
Governor: Type; Make/Model	Electronic
Frequency Regulation: No load to full load	Isochronous under varying loads from no load to 100% rated load
Frequency Regulation: Steady State	±0.25% of mean value for constant loads from no load to full load
Air Cleaner Type - All Models	Dry, Dual Element

Amperage				
Voltage	Phase	Power Factor	Amperes	
			Standby	Prime
277/480 Volt	3	0.8	2255	1879

Engine Electrical System	
Battery Charging Alternator Ground Type	Negative
Volts	24 VDC
Ampere Rating	45A
Starter Motor Rated Voltage	24 VDC
Minimum Recommended Battery for 0 °C / Cold Cranking Performance	1800 CCA

Exhaust System	
Exhaust Temperature at Rated kW (Standby)	965°F (520°C)
Exhaust Flow at Rated kW (Standby)	10690 cfm (302 m³/min)
Silencer Type	Critical
Maximum Allowable Backpressure	2 in/Hg (51 mm/Hg)
Exhaust Outlet Size at hook-up	8 in. (203 mm)



1500 kW Containerized Diesel Generator Set

Cooling System

Exhaust Manifold Type	Dry
Radiator Design	Standard Horizontal
Coolant Capacity - Engine Only	37 gal. (140 L)
Water Pump Design/Type	Belt Driven, Centrifugal
Coolant Flow	100 gal/min (378 L/min)
Heat Rejection to Coolant (Standby)	40600 Btu/min (715 kW)
Thermostat Range	180-200°F (82-93°C)

Fuel System

Recommended Fuel	ASTM-D975/No.1 or No.2-D
Fuel Pump Maximum Lift	6.0 ft. (1.8 m)
Filter Micron Size - 98% Efficiency	2
Total Fuel Flow	183 gal/hr (693 L/hr)
Fuel Consumption (Prime Power)	
At % of Load	gal/hr (L/hr)
25%	29.2 (111)
50%	47.6 (180)
75%	68.0 (257)
100%	87.3 (330)

Lubrication System

Type	Full Pressure System
Oil Filters	5 Spin-on Full Flow
Oil Pan Capacity	47 gal. (178 L)
Oil Capacity with Filters	54 gal. (204 L)
Oil Pressure At Rated Speed	50-70 psi (345-483 kPa)

Derating

Engine power available up to 1850 ft. altitude and 77°F ambient temperature at the Standby rating, without derating. For operation at higher altitudes and ambient temperatures, the power should be derated according to the following factors:	Altitude	Ambient Temperature
	Above 1850 ft. derate at 6% per 1000 ft.	Above 77°F derate at 1% per 10°F

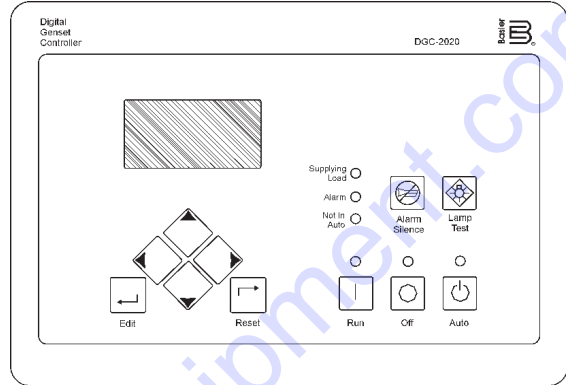

DGC2020 Digital Genset Controller

Digital Controller Features

- Local and Remote Generator Control
- Automatic and manual starting and stopping
- Engine and Generator Protection
- Programmable Analog Engine Senders
- ECU Communications via SAE J1939
- 16 Programmable Contact Inputs
- Programmable Logic
- Automatic Transfer Switch Control (Mains Failure)
- Integrated RS485 Modbus Connection
- Auto Synchronizing
- Event recording

Monitoring

- Engine RPM
- Engine run time
- Generator voltage
- Generator current
- Generator frequency
- Oil pressure
- Battery voltage
- Fuel level measurements
- Running Hour Meter
- Coolant temperature
- Generator under/over voltage alarm/shutdown
- Generator under/over frequency alarm/shutdown
- Over Current alarm/shutdown
- Warm up and cooling functions
- Maintenance timer



1500 kW Containerized Diesel Generator Set

Optional Features and Accessories

Generator Set

- Genset-to-Genset Paralleling Control System
- Base Load-to-Utility Paralleling Control System
- Custom Outlet Panels
- Rotary Voltage Selector Switch (High Wye/Low Wye Voltages)
- Auxiliary Oil Reservoir with Level Control (15-gallon)
- Centrifugal Oil Filter System
- Oil Pan Heater with Thermostat
- Alternator Strip Heater
- AC Battery Charger with Shore Power Receptacle
- 120VAC Convenience Receptacle
- Utility Grade Protective Relay

Container

- ISO Trailer Chassis (40 ft.)
- Double-wall Fuel Tank (900-gallon capacity)
- Fluid Containment
- Manual Fuel Valves (For Internal or External Fuel Supply)
- Entrance Ladder (Aluminum Construction)
- Fueling Ladder (Aluminum Step Construction with Hand Rail)
- Interior Lights (AC Work lights)
- Custom Paint Colors (Artic White is Standard)

SPECIAL OPTIONS AVAILABLE UPON REQUEST

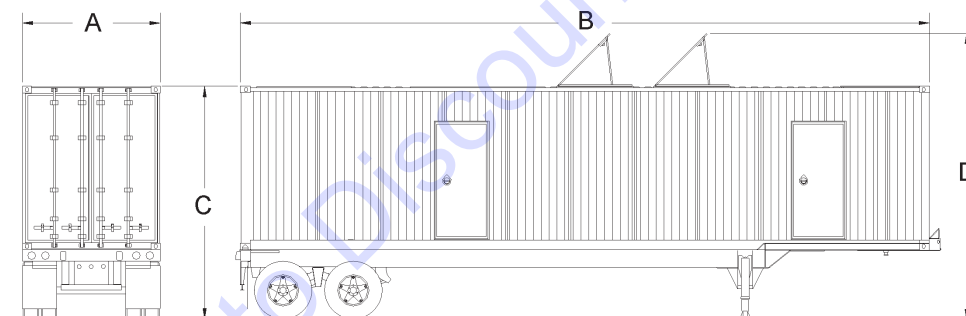

40 ft. Container

Weight and Dimensions			
A	B	C	D
96 in. (2,438 mm)	480 in. (12,192 mm)	163 in. (4,137 mm)	199 in. (5,054 mm)
Weight (Wet)*		46,480 lbs (21,083 kg)	
Weight (Wet with trailer)*		53,220 lbs (24,140 kg)	

* Weight is approximate. Wet weight does not include fuel.

Backfeed to a utility system can cause electrocution and/or property damage. Do not connect to any building's electrical system except through an approved device. Features and specifications are subject to change without notice.



TO PURCHASE THIS PRODUCT PLEASE CONTACT US



**Equipment Financing and
Extended Warranties Available**



**Discount-Equipment.com is your online resource for
commercial and industrial quality parts and equipment sales.**

561-964-4949

visit us on line @ www.discount-equipment.com

Select an option below to find your Equipment

Search by Manufacturer

Search by Product Type

Request a Quote

We sell worldwide for the brands: Genie, Terex, JLG, MultiQuip, Mikasa, Essick, Whiteman, Mayco, Toro Stone, Diamond Products, Generac Magnum, Airman, Haulotte, Barreto, Power Blanket, Nifty Lift, Atlas Copco, Chicago Pneumatic, Allmand, Miller Curber, Skyjack, Lull, Skytrak, Tsurumi, Husquvarna Target, Stow, Wacker, Sakai, Mi-T-M, Sullair, Basic, Dynapac, MBW, Weber, Bartell, Bennar Newman, Haulotte, Ditch Runner, Menegotti, Morrison, Contec, Buddy, Crown, Edco, Wyco, Bomag, Laymor, EZ Trench, Bil-Jax, F.S. Curtis, Gehl Pavers, Heli, Honda, ICS/PowerGrit, IHI, Partner, Imer, Clipper, MMD, Koshin, Rice, CH&E, General Equipment, Amida, Coleman, NAC, Gradall, Square Shooter, Kent, Stanley, Tamco, Toku, Hatz, Kohler, Robin, Wisconsin, Northrock, Oztec, Toker TK, Rol-Air, APT, Wylie, Ingersoll Rand / Doosan, Innovatech, Con X, Ammann, Mecalac, Makinex, Smith Surface Prep, Small Line, Wanco, Yanmar