



Count on it.

Parts Catalog

**TX 427 Wide Track Compact
Utility Loader**

Model No. 22322—Serial No. 313000001 and Up



Ordering Replacement Parts

To order replacement parts, please supply the part number, the quantity, and the description of each part desired.

Understanding Reference Numbers

Each identified part in an illustration has a reference number. The reference number for a part also appears in the parts list, along with other information about the part.

This catalog uses two special reference number formats, one to indicate parts in a service assembly and another to indicate the quantity of a given part in an illustration.

Service Assembly Reference Numbers

Parts in service assemblies have reference numbers in the form a:b. The a represents the reference number of the entire service assembly and the b represents a sequential number unique to each part within the service assembly.

For example, a wheel assembly might be identified by reference number 6, the tire by 6:1, the valve by 6:2, and the wheel by 6:3. When you order the assembly identified by reference number 6, you receive all parts identified by reference numbers 6:1, 6:2, and 6:3. However, you may also order any part individually. Reference numbers of this type appear in illustration and in parts lists.

Reference Numbers Indicating Quantity

In an illustration, if a reference number indicates more than one part, the reference number has the form nX y. The n represents the quantity of the part, the X is the multiplication symbol, and the y represents the reference number.

For example, in an illustration, the reference number 2X 37 means that two of the parts identified by reference number 37 are indicated.

List of Abbreviations

AR: as required

ASM: assembly

BBC: blade brake control

BHTF: button head thread forming

CARR: carriage

CCW: counter clockwise

CW: clockwise

DEG: degrees

DPA: Dual Point Adjustment

ECM: electronic control module

EXT: external

FH: flat head

GA: gauge

HD: heavy-duty

HF: hex flange

HH: hex head

HHF: hex head flange

HHFTF: hex head flange thread forming

HJ: hex jam

HLH: hex lag head

HOC: height-of-cut

HSBH: hex socket button head

HSFH: hex socket flat head

HSH: hex socket head

HWH: hex washer head

HWHTF: hex washer head thread forming

HYD: hydraulic

LH: left hand

LP: Liquefied Petroleum Gas

LPG: Liquefied Petroleum Gas

NI: nylon insert

NPTF: national pipe thread fine

PFH: phillips flat head

PPH: phillips pan head

PPHTF: phillips pan head thread forming

PRH: phillips round head

PTH: phillips truss head

PTO: power-take-off

RH: right hand

ROPS: roll-over protection system

RRB: rear roller brush

SFH: slotted fillister head

SHH: slotted hex head

SHWH: slotted hex washer head

SPH: slotted pan head

SQH: square head

SRH: slotted round head

STD: standard

TAP: self tapping

TTH: torx truss head

Contents

Main Frame and Fuel Tank Assembly	4
Track and Traction Assembly	6
Parking Brake Assembly	7
Loader Tower and Pulley Assembly	8
Traction Hydraulic Assembly	9
Hydraulic Pump Assembly No. 106-5705 and 106-5706	11
Hydraulic Motor Assembly No. 114-1756	12
Engine Assembly	13
Air Cleaner Assembly No. 117-9989	15
Hydraulic Pump and Filter Assembly	16
Hydraulic Gear Pump Assembly No. 106-7650	17
Control Panel Assembly	18
Traction Control Assembly	20
Principal Hydraulic Assembly	21
Two Spool Valve Assembly No. 106-9307	23
One Spool Valve Assembly No. 104-2831	24
Loader Arm Assembly	25
Loader Arm Hydraulic Assembly	26
Left Hand Hydraulic Lift Cylinder Assembly No. 104-6267	27
Right Hand Hydraulic Lift Cylinder Assembly No. 104-6269	28
Hydraulic Cylinder Assembly No. 105-8370	29
Quick Attach Assembly	30
Electrical System Assembly	31
Grill Assembly	32
Hydraulic Oil Cooler Assembly	33
Hood Assembly	34
Rear Access Cover Assembly	35
Attachments and Accessories	36

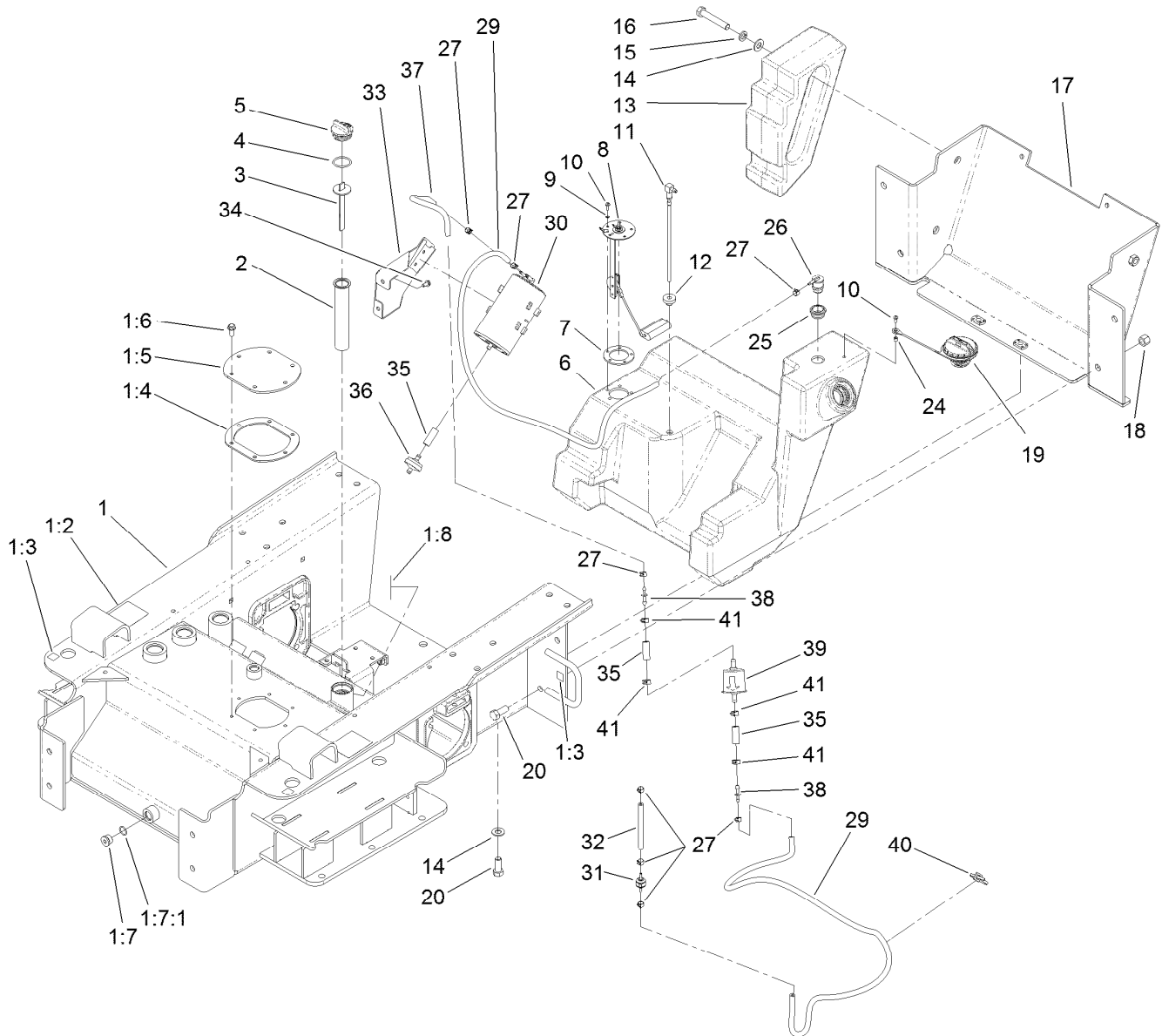

Main Frame and Fuel Tank Assembly

Ref.	Part Number	Qty.	Description	Ref.	Part Number	Qty.	Description
1	114-1352	1	Chassis ASM	14	3256-26	6	Washer-Flat
1:2	100-4650	2	Decal-Warning	15	3253-7	4	Washer-Lock
1:3	93-9084	4	Decal-Point, Lift	16	325-12	4	Screw-HH
1:4	107-3557	1	Gasket-Cover, Access	17	115-4565-01	1	Cover-Rear
1:5	108-6297-01	1	Cover-Tank	18	3296-23	4	Nut-Lock, NI
1:6	98-9940	6	Screw	19	117-1722	1	Cap-Fuel
1:7	353-988	2	Plug-Hex	20	325-5	6	Screw-HH
1:7:1	237-79	1	O-Ring	24	117-9965	1	Spacer
1:8	93-6686	1	Decal-Oil, HYD	25	114-0284	1	Grommet
2	61-2790	1	Filter-Screen	26	114-0285	1	Valve-Rollover
3	100-2097	1	Dipstick-Oil	27	2412-146	8	Clamp-Hose
4	237-123	1	O-Ring	29	119-3517	2	Hose-Fuel
5	93-7498	1	Plug-Plastic	30	115-2251	1	Canister-Carbon
6	117-9956	1	Tank-Fuel	31	115-7868	1	Valve-Check, Vacuum
7	113372	1	Gasket-Sender, Fuel	32	115-4736	1	Hose-Fuel
8	100-1298	1	Sender-Fuel	33	117-4043	1	Holder-Canister
9	3253-17	5	Washer-Lock	34	9266714	2	Screw-HWH
10	3250-31	6	Screw-PPH	35	106-5317	3	Hose-Fuel
11	98-0185	1	Stand-Pipe	36	115-7854	1	Filter-Fuel, Inline
12	46-6560	1	Bushing	37	51-3217	1	Hose-Fuel
13	99-6165-01	2	Counterweight-Rear	38	106-8150	2	Fitting-Straight

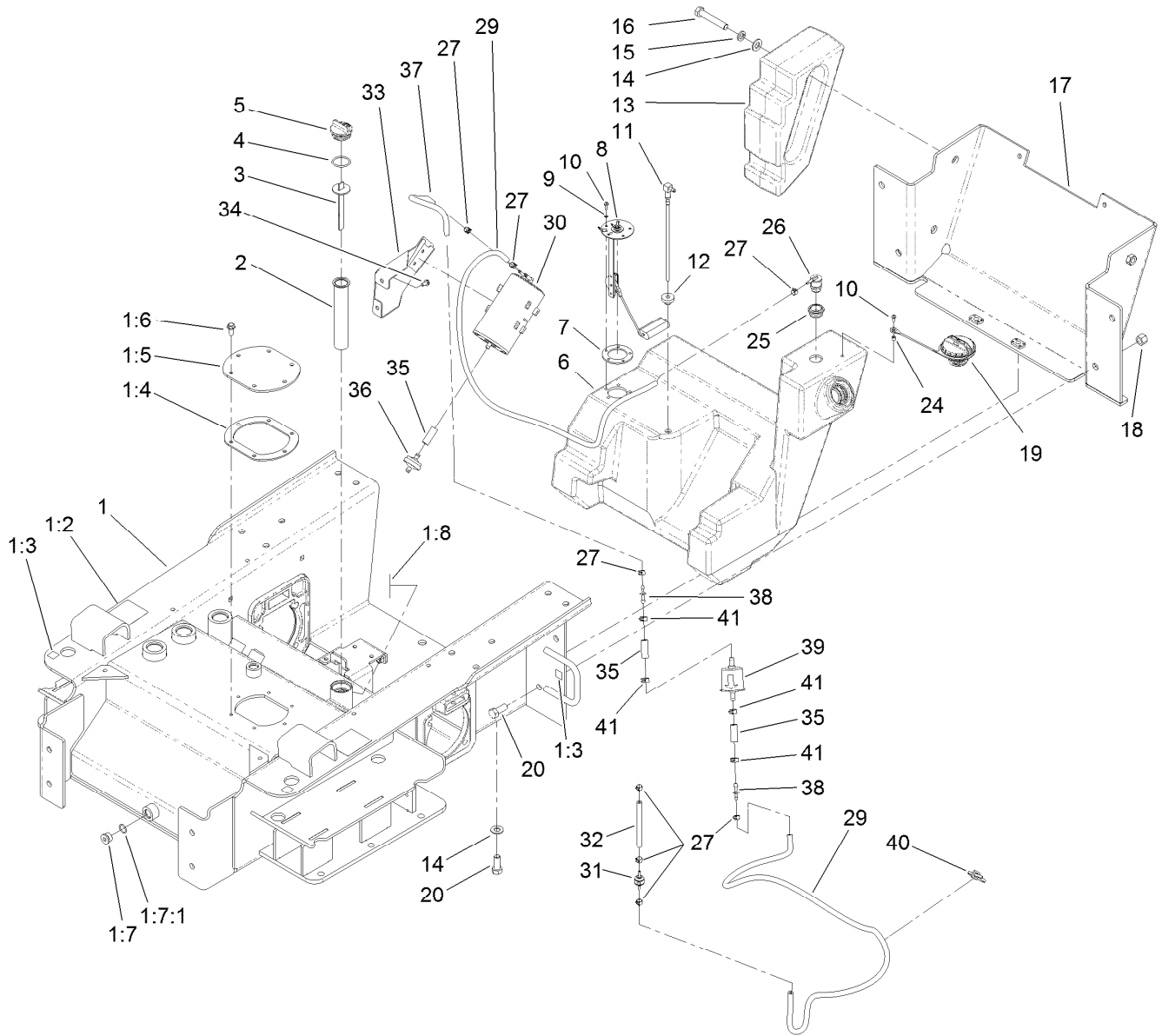

Main Frame and Fuel Tank Assembly (continued)

Ref.	Part Number	Qty.	Description
39	120-2235	1	Filter-Fuel

Ref.	Part Number	Qty.	Description
40	3290-378	1	Tie-Cable
41	92-2379	4	Clamp-Hose

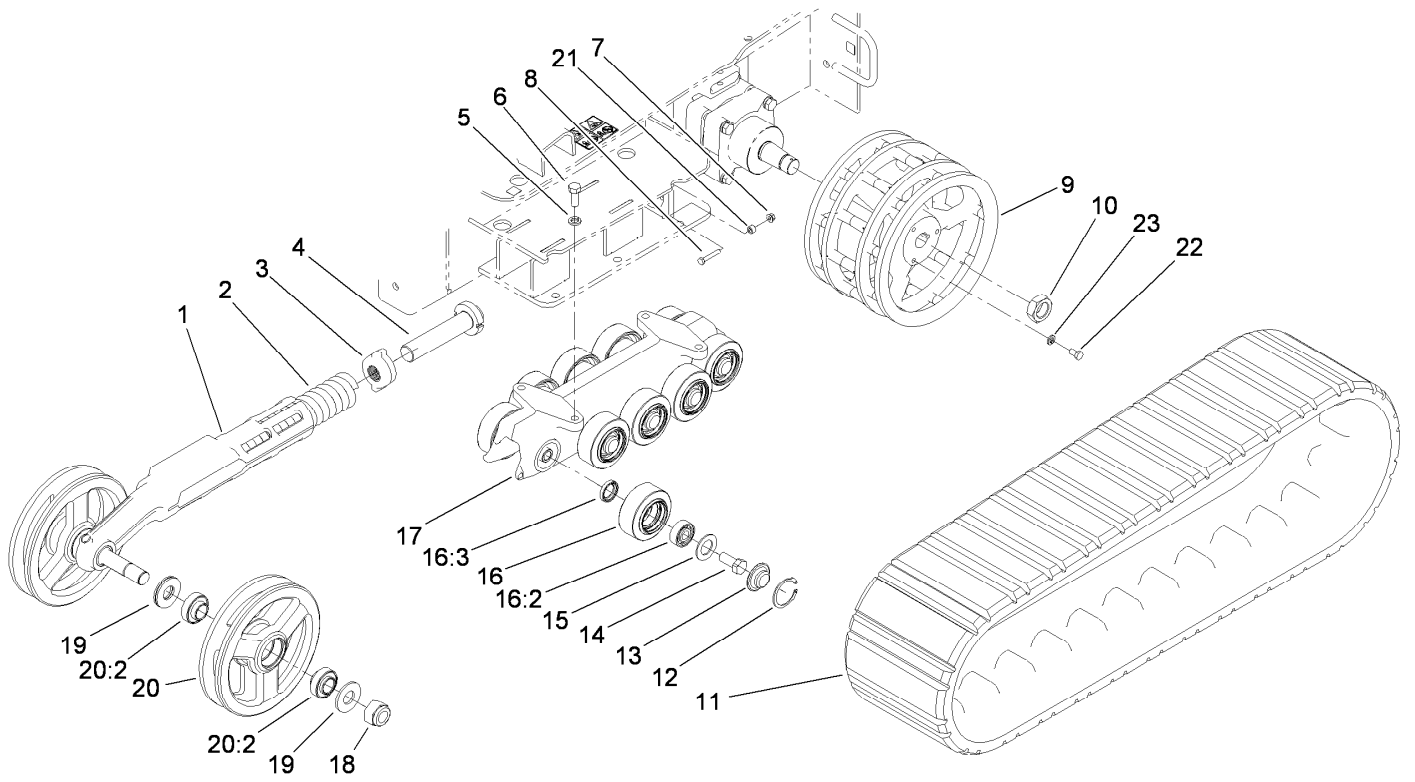

Track and Traction Assembly

<i>Ref.</i>	<i>Part Number</i>	<i>Qty.</i>	<i>Description</i>	<i>Ref.</i>	<i>Part Number</i>	<i>Qty.</i>	<i>Description</i>
1	115-0717-03	2	Arm-Tensioner	14	327-4	20	Screw-HH
2	95-3624	2	Spring-Compression	15	106-7585	20	Gasket-Bogie
3	108-4664	2	Block-Tensioner	16	106-7621	20	Road Wheel ASM
4	98-9846	2	Bolt-Tensioner	16:2	120-5378	1	Bearing-Ball
5	3253-7	8	Washer-Lock	16:3	253-118	1	Seal-Oil
6	325-5	8	Screw-HH	17	117-1308-03	2	Guide-Track
7	32128-32	2	Nut-HHF	18	104-2024	4	Nut-Hex, NI
8	321-37	2	Screw-HH	19	115-0722	8	Washer-Plain
9	115-0721-03	2	Wheel-Drive	20	104-6123	4	Tensioner Wheel ASM
10	107-9319	2	Nut-Hex	20:2	104-6129	2	Bearing-Ball
11	100-8931	2	Track	21	98-4799	2	Spacer
12	106-7595	20	Ring-Snap, Internal	22	323-34	6	Screw-HH
13	106-7557	20	Cap-Wheel, Bearing	23	3253-21	6	Washer-Lock

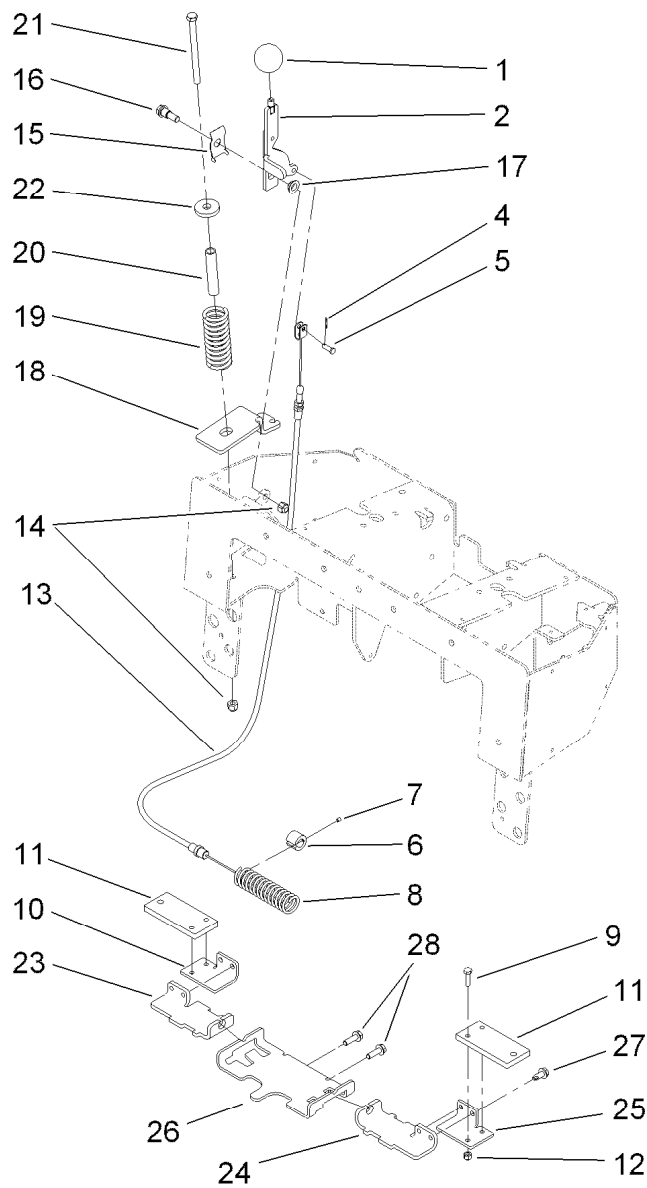

Parking Brake Assembly

<i>Ref.</i>	<i>Part Number</i>	<i>Qty.</i>	<i>Description</i>	<i>Ref.</i>	<i>Part Number</i>	<i>Qty.</i>	<i>Description</i>
1	233-21	1	Knob	16	94-6177	1	Bolt-Shoulder
2	112-2694-03	1	Handle-Brake	17	93-2368	1	Bushing-Flange
4	3272-1	1	Pin-Cotter	18	115-4854-03	1	Bracket-Cable, Spring
5	283-67	1	Pin-Clevis	19	114-1254	1	Spring-Compression
6	100-6274	2	Tube-Guide	20	114-1255	1	Spacer-Spring
7	3245-20	2	Screw-HSH	21	323-39	1	Screw-HH
8	100-1678	1	Spring	22	98-0691	1	Washer-Hardened
9	321-6	4	Screw-HH	23	112-2788-03	1	Bracket-Mounting, Brake RH
10	112-2789-03	1	Bar-Link, Brake RH	24	112-2733-03	1	Bracket-Mounting, Brake LH
11	112-2735-03	2	Plate-Brake	25	112-2734-03	1	Bar-Link, Brake LH
12	3296-42	4	Nut-Lock, NI	26	110-0224-03	1	Support-Bar, Brake
13	112-2791	1	Cable-Brake	27	32104-32	4	Screw-HWH
14	3296-39	2	Nut-Lock, NI	28	3234-11	2	Screw-HHF
15	112-2695	1	Spring-Leaf				

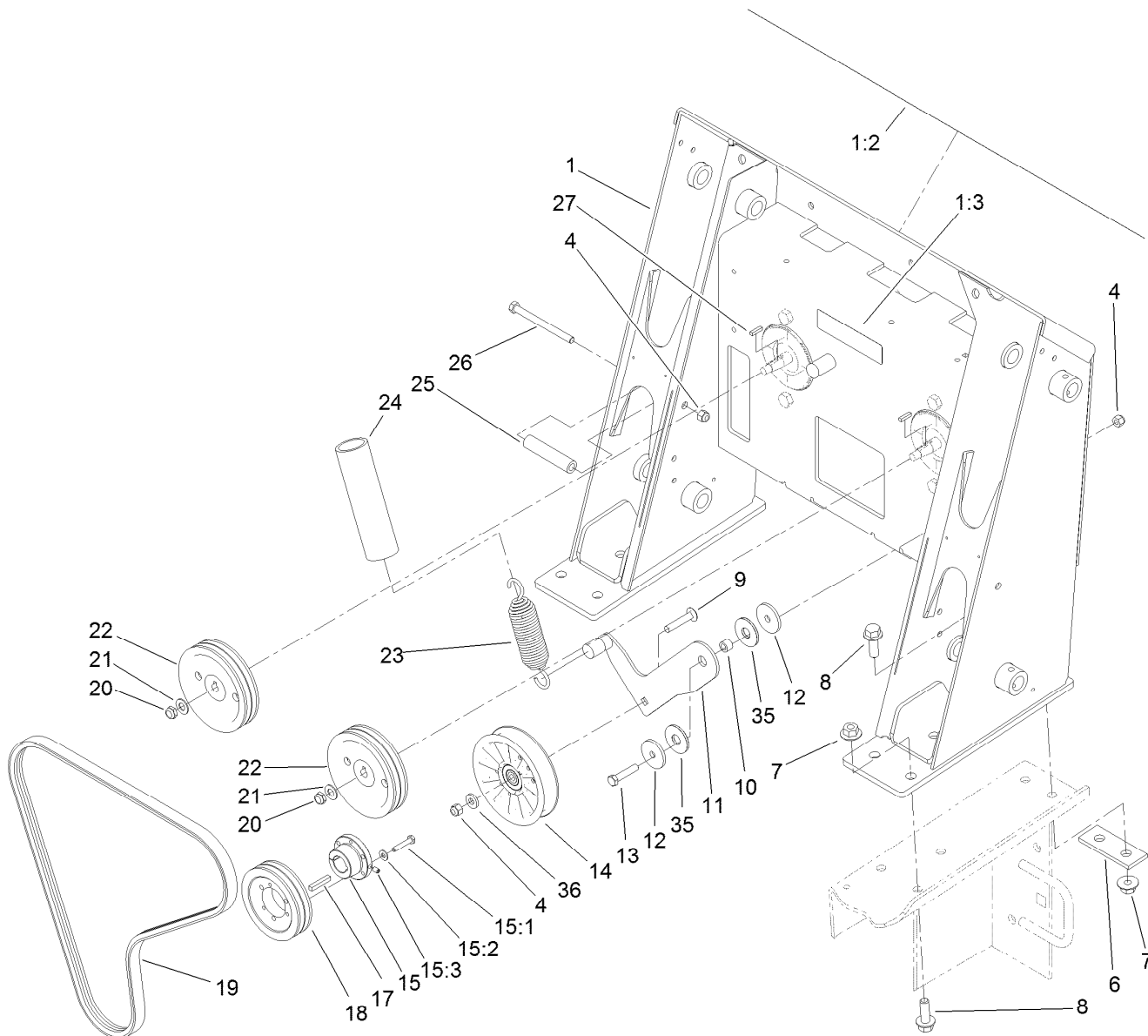

Loader Tower and Pulley Assembly

<i>Ref.</i>	<i>Part Number</i>	<i>Qty.</i>	<i>Description</i>	<i>Ref.</i>	<i>Part Number</i>	<i>Qty.</i>	<i>Description</i>
1	117-9982	1	Loader Tower ASM	15:2	3253-2	3	Washer-Lock
1:2	117-4045	1	Decal-Panel, Control	15:3	3245-2	1	Screw-Set, HSH
1:3	93-7814	1	Decal-Danger	17	67-7490	1	Key-Square
4	104-8301	4	Nut-Flange, NI	18	61-3330	1	Pulley
6	100-6123-01	2	Plate-Stiffener	19	95-3611	1	V-Belt
7	32128-52	10	Locknut-Flange	20	3296-38	2	Nut-Lock, NI
8	100-6116	10	Screw-HHF	21	3256-25	2	Washer-Flat
9	117-9971	1	Bolt-Carriage	22	106-5710	2	Pulley-3V
10	115-4986	1	Spacer	23	105-0383	1	Spring-Extension
11	115-1486	1	Arm-Idler	24	112-2409	1	Retainer-Spring
12	115-1485	2	Washer-Plain	25	100-1271	2	Tube-Spacer
13	323-9	1	Screw-HH	26	323-23	2	Screw-HH
14	119-2358	1	Pulley-Idler	27	3-6168	2	Key
15	61-3340	1	Bushing	35	114-0463	2	Washer-Friction, Composite
15:1	321-13	3	Screw-HH	36	43-0940	1	Spacer

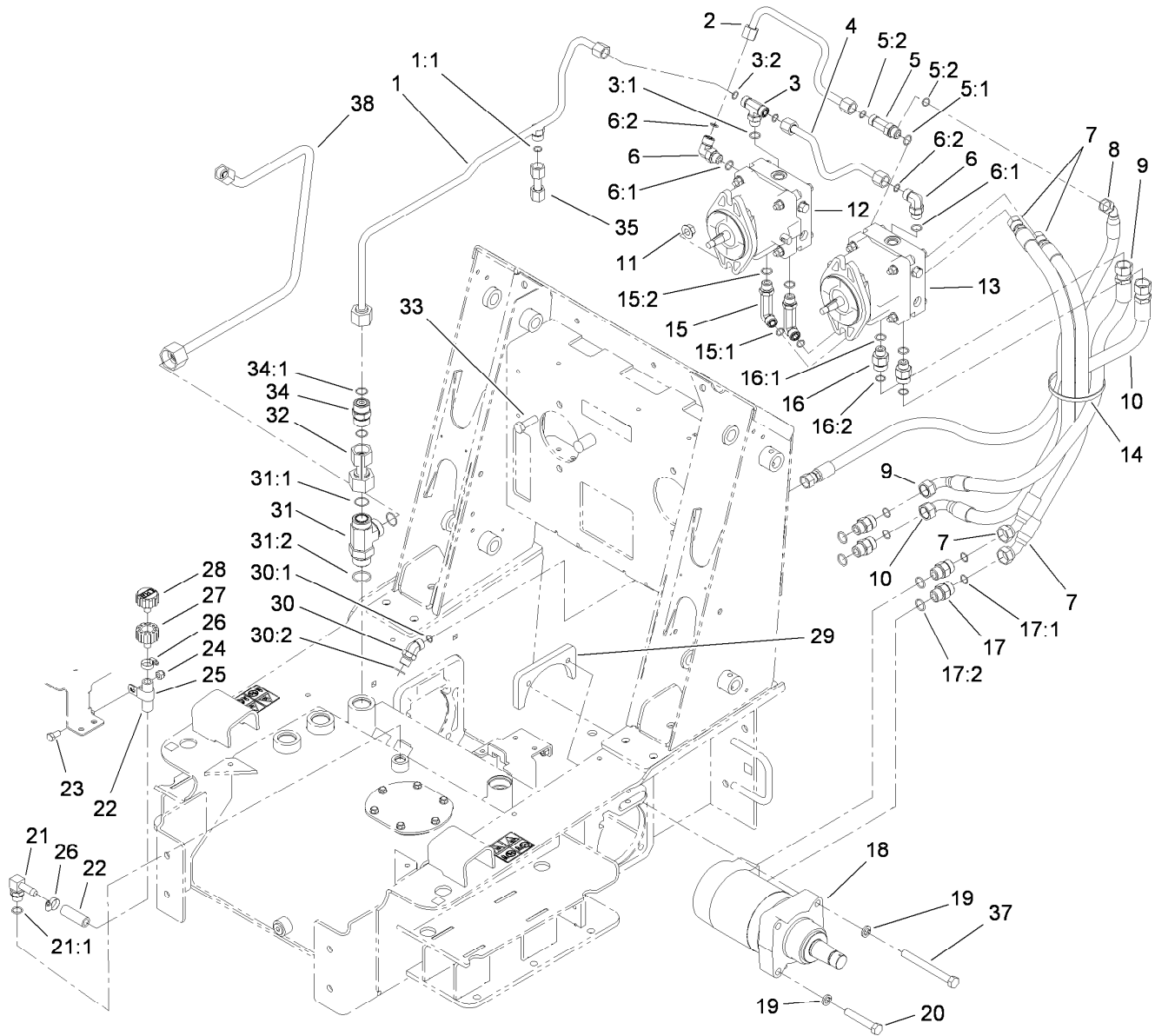

Traction Hydraulic Assembly

Ref.	Part Number	Qty.	Description	Ref.	Part Number	Qty.	Description
1	108-4665	1	HYD Tube ASM	15	99-6160	2	Fitting-Elbow, 90 DEG
1:1	237-30	1	O-Ring	15:1	237-30	1	O-Ring
2	98-0200	1	HYD Tube ASM	15:2	237-79	1	O-Ring
3	340-157	1	Fitting-HYD, Tee	16	340-155	2	Fitting-HYD, Straight
3:1	237-79	1	O-Ring	16:1	237-79	1	O-Ring
3:2	237-30	2	O-Ring	16:2	237-151	1	O-Ring
4	106-9330	1	HYD Tube ASM	17	340-7	4	Adapter
5	340-109	1	Fitting-HYD, Tee	17:1	237-65	1	O-Ring
5:1	237-79	1	O-Ring	17:2	237-80	1	O-Ring
5:2	237-30	2	O-Ring	18	114-1756	2	HYD Motor ASM
6	340-98	2	Fitting-HYD, 90 DEG	19	3253-7	8	Washer-Lock
6:1	237-79	1	O-Ring	20	115-4845	4	Screw-HH, TAP
6:2	237-30	1	O-Ring	21	354-120	1	Fitting-HYD, 90 DEG
7	98-0233	2	HYD Hose ASM	21:1	237-79	1	O-Ring
8	98-0201	1	HYD Hose ASM	22	98-4667	1	Hose
9	115-4826	1	HYD Hose ASM	23	3234-42	1	Screw-HHF
10	115-4829	1	HYD Hose ASM	24	3296-39	1	Nut-Lock, NI
11	32128-52	4	Locknut-Flange	25	2412-4	1	Clamp
12	106-5706	1	RH HYD Pump ASM	26	2412-36	2	Clamp-Hose
13	106-5705	1	LH HYD Pump ASM	27	92-8020	1	Adapter-Breather
14	3334-945	1	Tie-Cable	28	68-6150	1	Breather

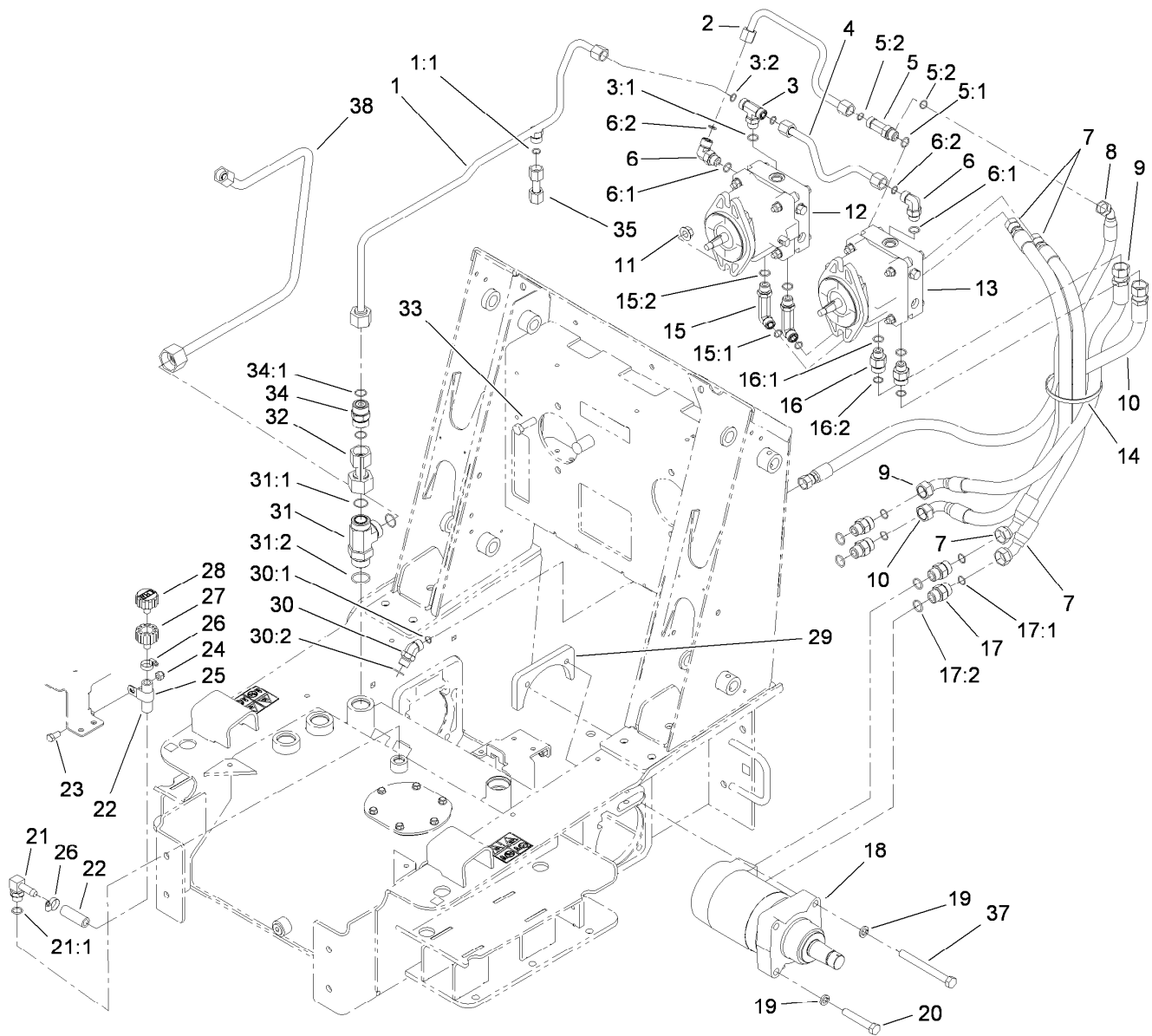

Traction Hydraulic Assembly (continued)

<i>Ref.</i>	<i>Part Number</i>	<i>Qty.</i>	<i>Description</i>	<i>Ref.</i>	<i>Part Number</i>	<i>Qty.</i>	<i>Description</i>
29	98-2763-03	2	Plate-Mounting	32	105-0226	1	HYD Tube ASM
30	340-101	1	Fitting-HYD, 45 DEG	33	325-6	4	Screw-HH
30:1	237-30	1	O-Ring	34	99-6161	1	HYD Check Valve ASM
30:2	237-79	1	O-Ring	34:1	237-58	2	O-Ring
31	104-3795	1	Fitting-HYD, Tee	35	108-4666	1	HYD Tube ASM
31:1	340-65	2	O-Ring	37	325-19	4	Screw-HH
31:2	237-146	1	O-Ring	38	117-3988	1	HYD Tube ASM

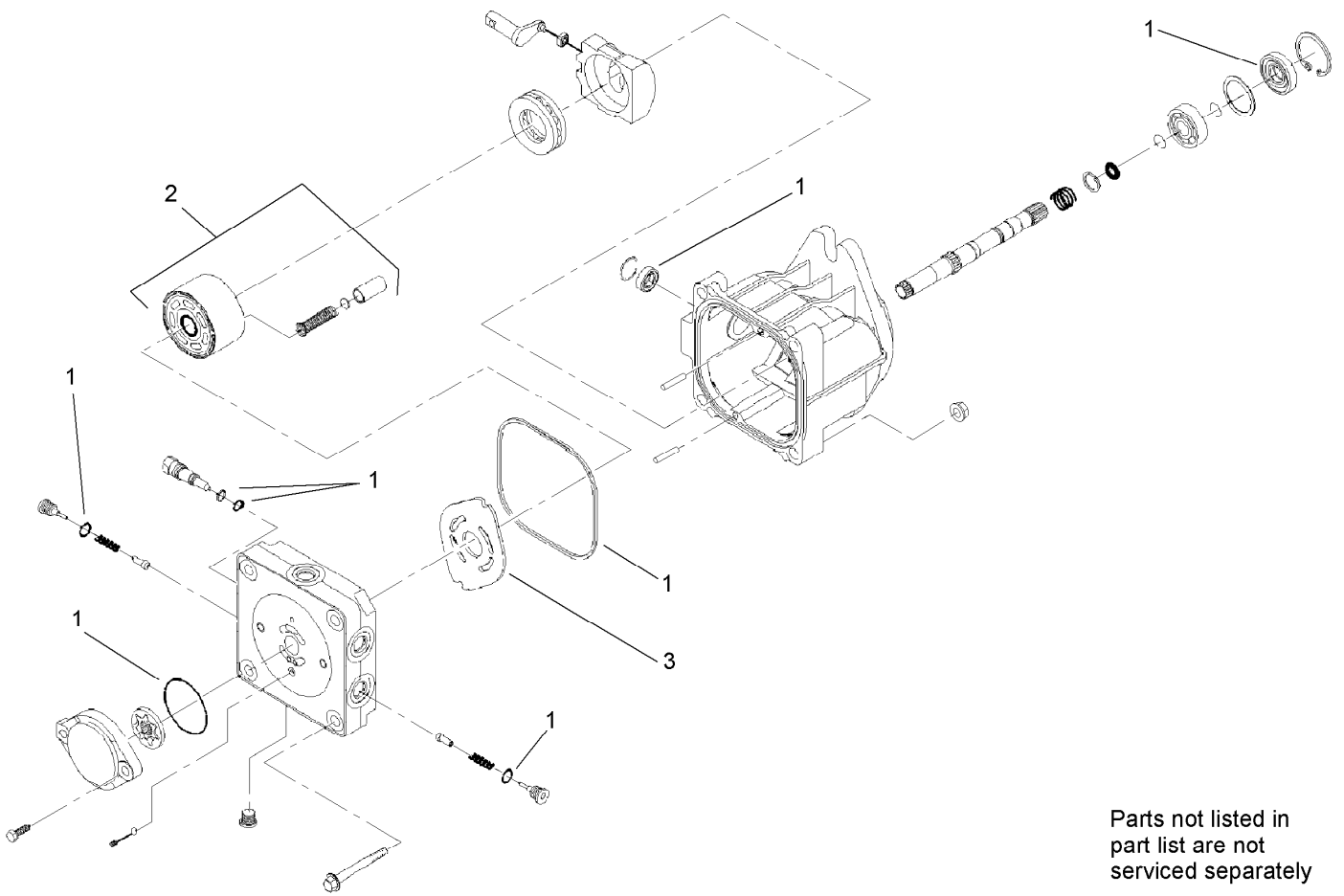

Parts not listed in
part list are not
serviced separately

Hydraulic Pump Assembly No. 106-5705 and 106-5706

<i>Ref.</i>	<i>Part Number</i>	<i>Qty.</i>	<i>Description</i>
1	100-6110	1	Overhaul Seal Kit
2	94-1913	1	Cylinder Block ASM
3	100-6112	1	Plate-Valve

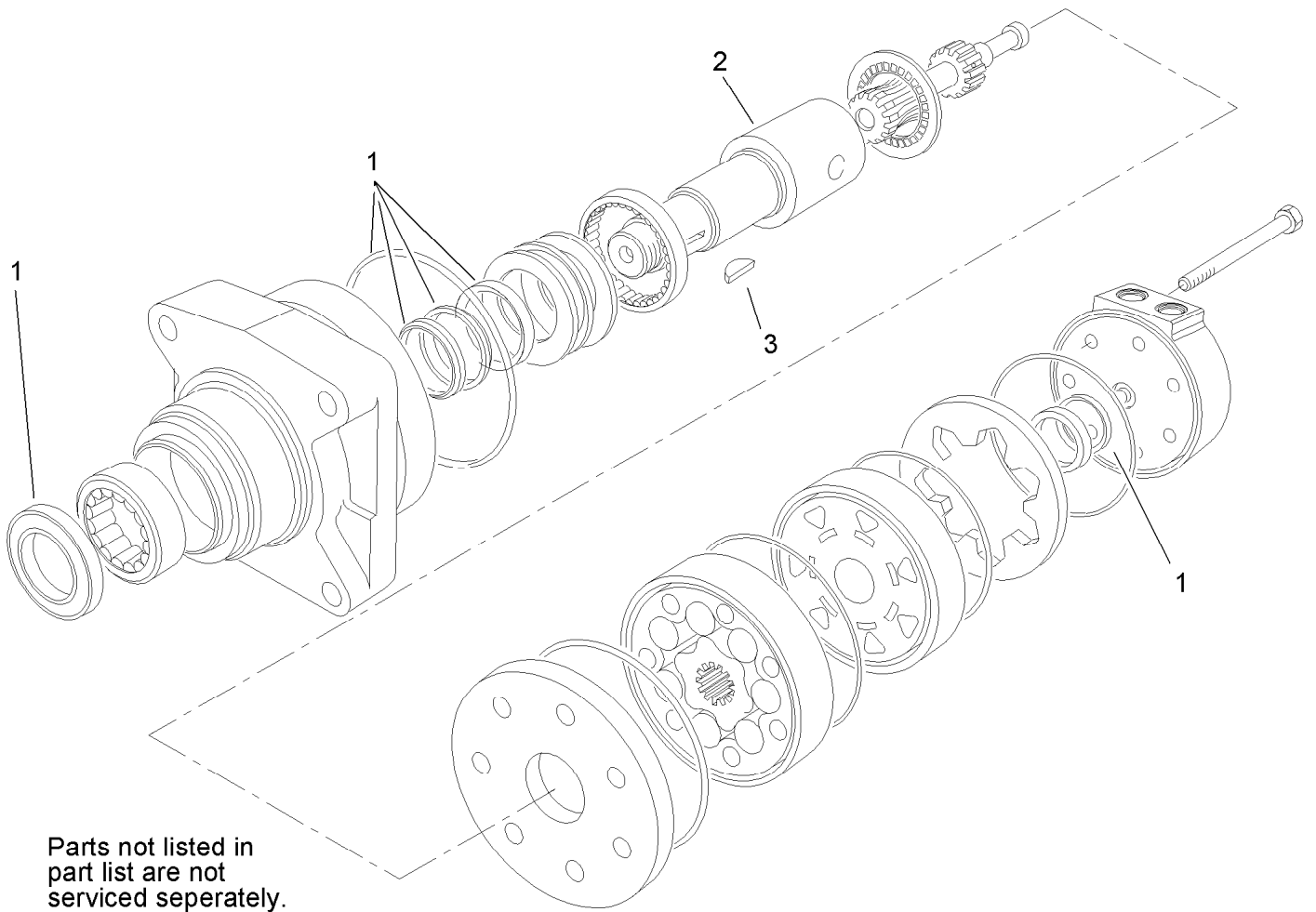

Hydraulic Motor Assembly No. 114-1756

<i>Ref.</i>	<i>Part Number</i>	<i>Qty.</i>	<i>Description</i>
1	100-6131	1	Seal Kit
2	106-7645	1	Coupling-Shaft
3	3257-42	1	Key-Woodruff

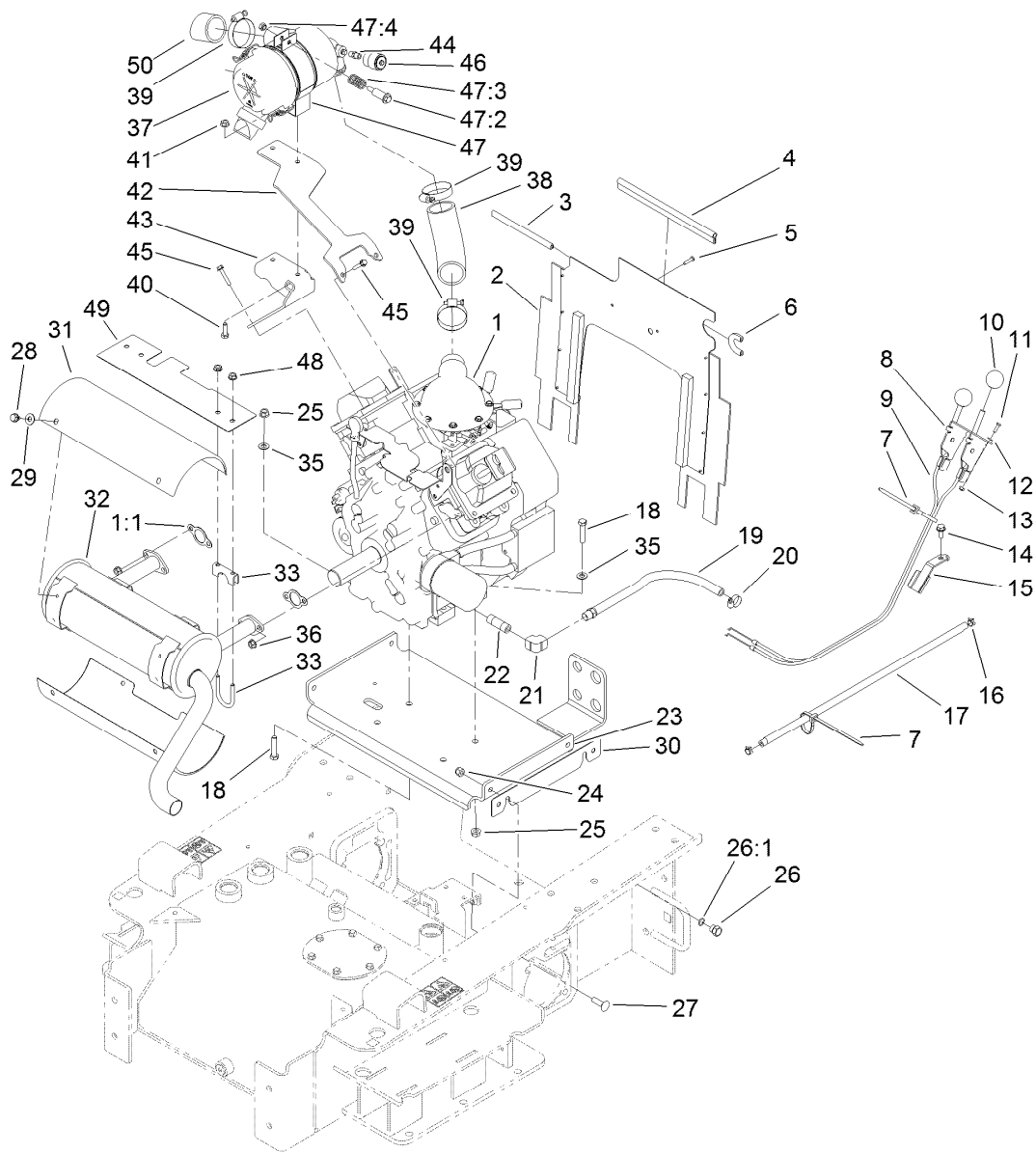

Engine Assembly

Ref.	Part Number	Qty.	Description	Ref.	Part Number	Qty.	Description
1		1	Engine-Kohler, Ch740-3136 ● ■	17	109-0301	1	Hose-Fuel
1:1	93-0350	2	Gasket-Exhaust	18	323-53	4	Screw-HH
2	114-8725	1	Baffle-Engine	19	100-1256	1	Oil Hose ASM
3	105-0378	1	Seal-Strip, 6.5 Inch	20	2412-36	1	Clamp-Hose
4	115-4837	1	Strip-Seal, 10.5 Inch	21	94-9650	1	Elbow-90 DEG
5	32144-36	2	Screw-PPH	22	289-42	1	Nipple
6	105-0377	1	Seal-Strip, 3 Inch	23	114-1288-03	1	Plate-Mounting, Engine
7	3290-378	2	Tie-Cable	24	3296-39	4	Nut-Lock, NI
8	108-9730	2	Lever-Control	25	32128-21	4	Nut-HF
9	108-4679	2	Cable-Throttle/Choke	26	353-508	1	Plug-HH
10	233-42	2	Knob	26:1	237-42	1	O-Ring
11	3290-134	4	Screw	27	3231-28	4	Screw-CARR
12	3256-51	4	Washer-Flat	28	9266934	8	Screw
13	32149-7	4	Nut-Keps	29	3256-3	8	Washer-Flat
14	32144-11	1	Screw-HWHTF	30	117-1811	1	Shim-Strap
15	100-1299-03	1	Guide-Cable	31	117-9973	2	Shield-Muffler
16	2412-98	2	Clamp-Hose	32	115-1509	1	Muffler
				33	114-1365	2	Clamp-Muffler, 1.125 Inch

● Not serviced separately

■ Obtain parts from www.kohlerplus.com

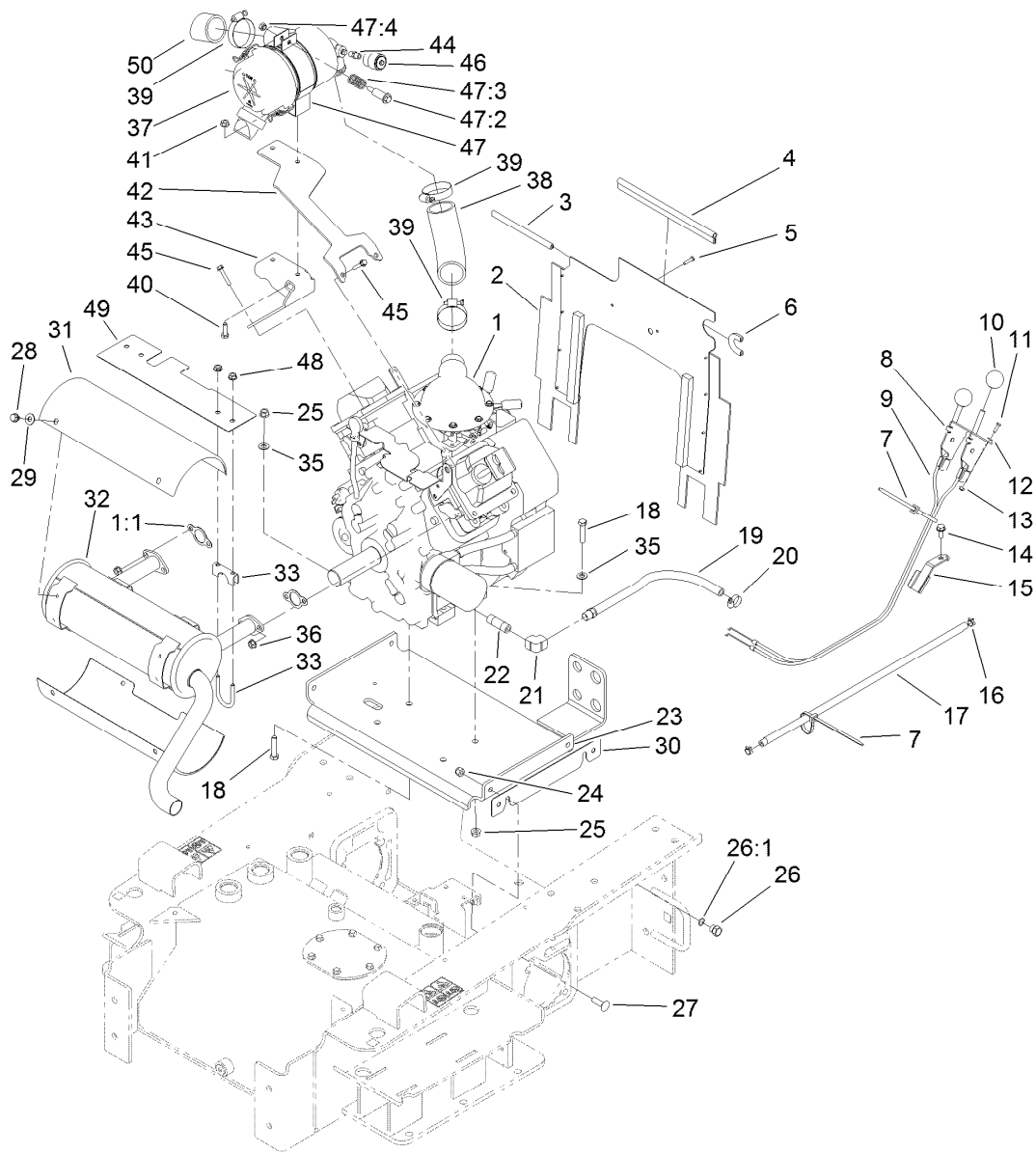

Engine Assembly (continued)

<i>Ref.</i>	<i>Part Number</i>	<i>Qty.</i>	<i>Description</i>	<i>Ref.</i>	<i>Part Number</i>	<i>Qty.</i>	<i>Description</i>
35	48-9220	4	Washer	44	105-4292	1	Nipple-Pipe
36	112-2844	4	Nut-HF	45	33103-035	4	Screw-HHF
37	117-9989	1	Air Cleaner ASM	46	93-9164	1	Indicator-Mini
38	114-8734	1	Hose-Air Cleaner	47	93-2191	1	Mounting Band ASM (Air Cleaner)
39	2412-92	3	Clamp-Hose	47:2	94-3653	1	Bolt
40	322-5	2	Screw-HH	47:3	94-3654	1	Spring
41	32128-20	2	Nut-HF	47:4	48-9510	1	Nut
42	117-1728-03	1	Bracket-Left Support, Air Cleaner	48	32128-25	4	Nut-HF
43	117-1729-03	1	Bracket-Right Support, Air Cleaner	49	114-1366	1	Shield-Manifold
				50	114-1364	1	Tube-Inlet, Air

● Not serviced separately

■ Obtain parts from www.kohlerplus.com

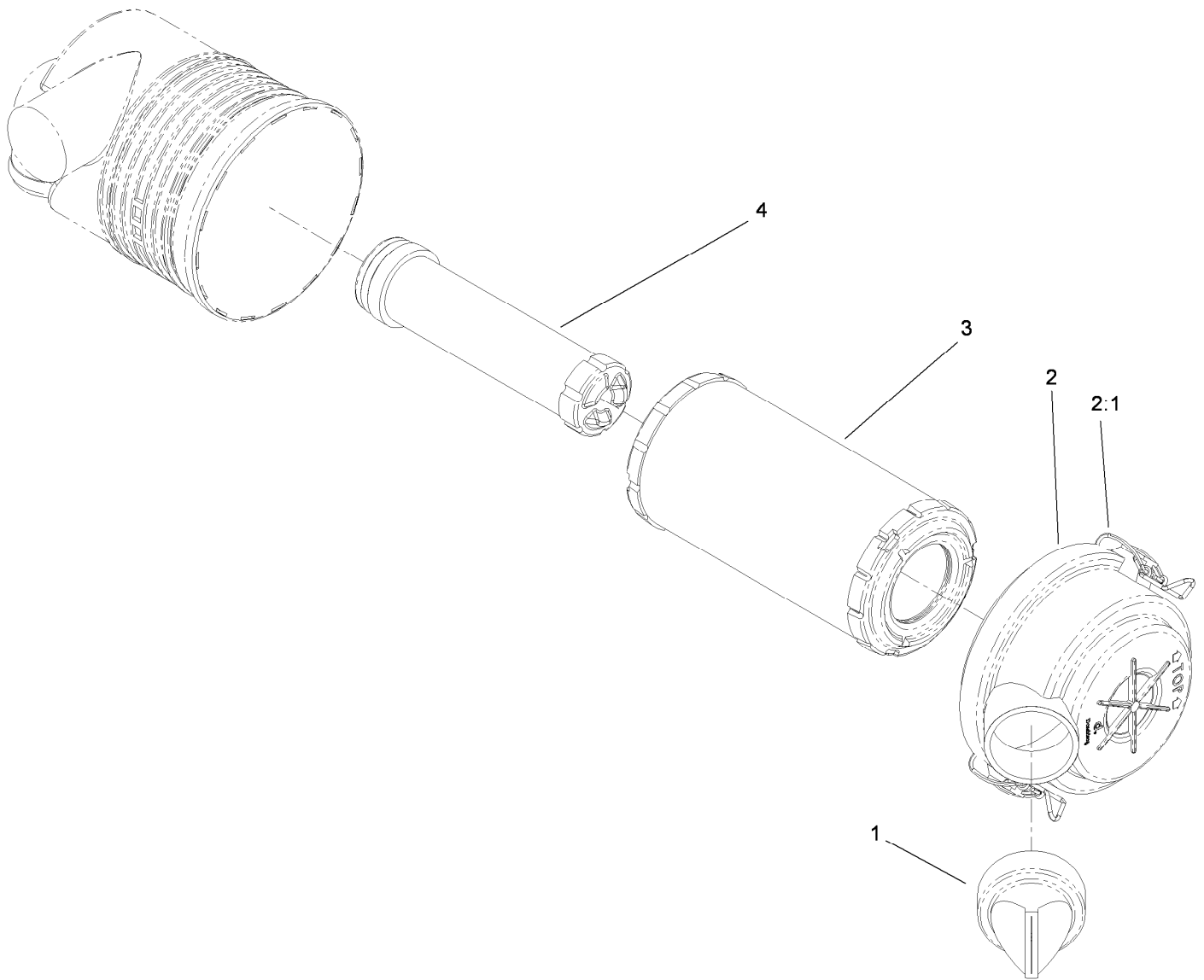

Air Cleaner Assembly No. 117-9989

<i>Ref.</i>	<i>Part Number</i>	<i>Qty.</i>	<i>Description</i>
1	87-9400	1	Valve-Vacuator
2	94-3652	1	Cover ASM
2:1	1-643283	2	Latch-Cleaner, Air
3	108-3811	1	Filter-Air
4	98-2982	1	Filter-Element, Safety

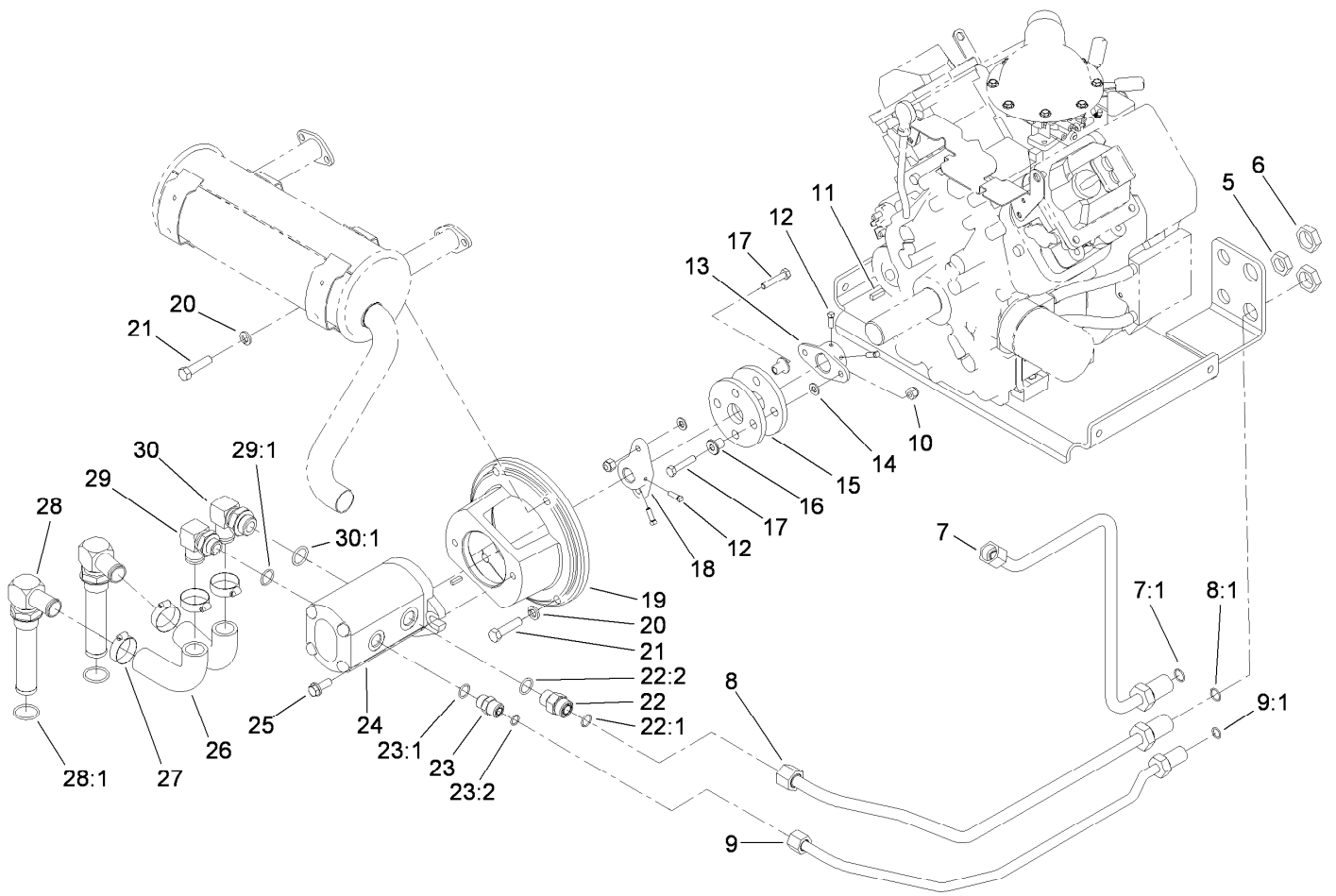

Hydraulic Pump and Filter Assembly

Ref.	Part Number	Qty.	Description	Ref.	Part Number	Qty.	Description
5	340-127	1	Nut-Bulkhead	20	3253-6	4	Washer-Lock
6	340-74	2	Nut-Lock, Bulkhead	21	324-7	4	Screw-HH
7	106-9333	1	HYD Tube ASM	22	340-7	1	Adapter
7:1	237-65	1	O-Ring	22:1	237-65	1	O-Ring
8	114-1355	1	HYD Tube ASM	22:2	237-80	1	O-Ring
8:1	237-65	1	O-Ring	23	340-4	1	Fitting-HYD, Straight
9	114-1356	1	HYD Tube ASM	23:1	237-30	1	O-Ring
9:1	237-30	1	O-Ring	23:2	237-79	1	O-Ring
10	3296-29	4	Nut-Lock, NI	24	106-7650	1	HYD Pump ASM
11	10-7070	1	Key-Square	25	66-9300	2	Screw-HHF
12	3241-6	4	Screw-SQH	26	105-0201	2	Hose-Suction, Formed
13	110-5236	1	Hub-Engine	27	2412-34	4	Clamp-Hose
14	3256-23	4	Washer-Flat	28	105-0204	2	Strainer Fitting ASM
15	115-4523	2	Coupling-Rubber	28:1	237-146	1	O-Ring
16	71-4411	4	Spacer	29	61-2710	1	Stem-Hose, 90 DEG
17	322-8	4	Screw-HH	29:1	237-117	1	O-Ring
18	110-9695	1	Hub-Pump	30	100-4202	1	Fitting-HYD, 90 DEG
19	98-2751-03	1	Mount-Pump	30:1	237-81	1	O-Ring

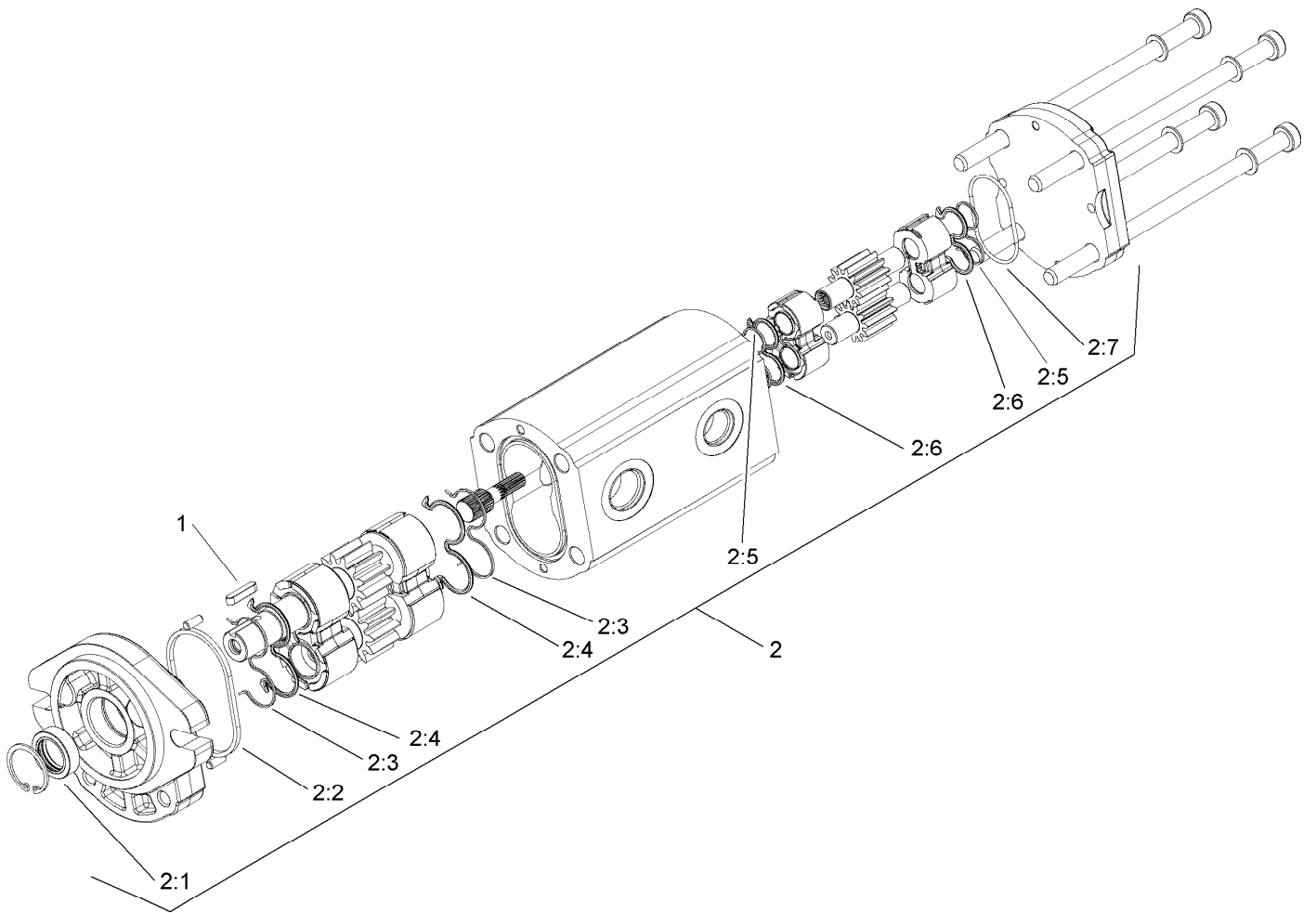

Hydraulic Gear Pump Assembly No. 106-7650

<i>Ref.</i>	<i>Part Number</i>	<i>Qty.</i>	<i>Description</i>
1	100-4238	1	Key-Square
2	107-9316	1	Seal Kit
2:1		1	Seal-Shaft ●
2:2		1	Seal-Square ●
2:3		2	Ring-Backup ●
2:4		2	Seal-Gear ●
2:5		2	Ring-Backup ●
2:6		2	Seal-Gear-Rear ●
2:7		1	O-Ring ●

● Not serviced separately

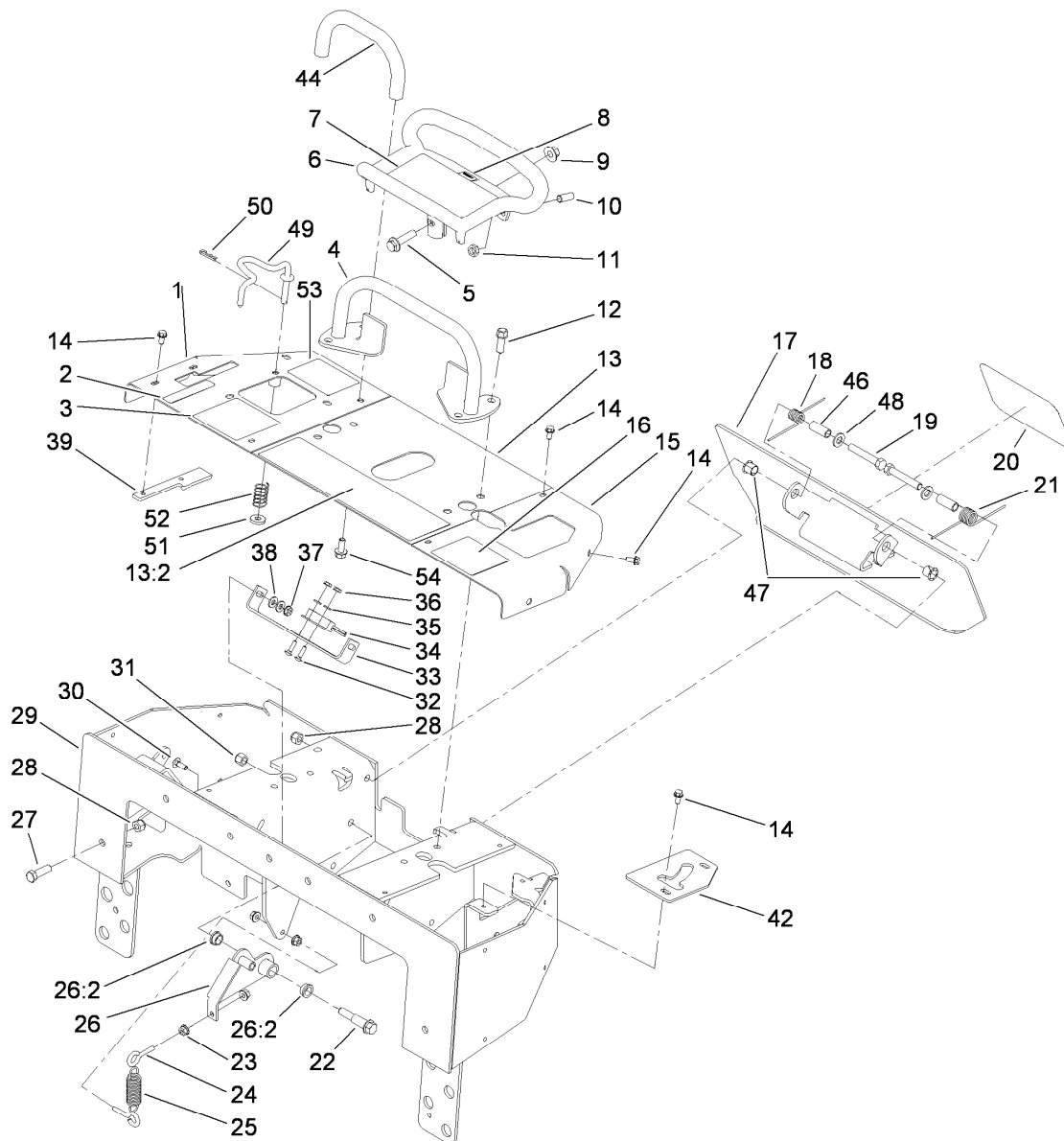

Control Panel Assembly

Ref.	Part Number	Qty.	Description	Ref.	Part Number	Qty.	Description
1	115-4836-01	1	Panel-RH	21	98-8424	1	Spring-Torsion, RH
2	115-4859	1	Decal-Brake	22	66-0560	1	Bolt-Shoulder
3	115-4857	1	Decal-Control, Loader	23	32128-32	4	Nut-HHF
4	106-7715	1	Bar-Reference	24	71-2870	2	Bolt-Eye
5	3234-18	1	Screw-HHF	25	108-4724	1	Spring-Extension
6	106-7614-03	1	Handle-Control	26	100-4203	1	Neutral Centering Lever ASM
7	115-4020	1	Decal-Traction	26:2	256-156	2	Bushing-Flange
8	98-1459	1	Decal	27	323-7	5	Screw-HH
9	32128-43	1	Nut-Flange	28	3296-39	7	Nut-Lock, NI
10	3247-6	2	Screw-Set	29	110-0228-01	1	Panel-Control
11	3218-3	2	Nut-Jam	30	3229-1	2	Bolt-CARR
12	95-1726	4	Screw-Taptite	31	3296-6	1	Nut-Lock
13	108-4643	1	Center Panel ASM	32	3229-20	2	Screw-CARR
13:2	115-4860	1	Decal-Danger	33	100-1263	1	Plate-Switch
14	9266714	11	Screw-HWH	34	100-1270	1	Switch-Proximity
15	112-2737-01	1	Panel-LH	35	3256-51	2	Washer-Flat
16	115-4861	1	Decal-Control, Auxiliary	36	32149-7	2	Nut-Keps
17	112-2786-03	1	Plate-Reverse	37	32149-2	2	Nut-Keps
18	98-8425	1	Spring-Torsion, LH	38	3256-22	4	Washer-Flat
19	323-11	2	Screw-HH	39	112-2691-01	1	Plate-Locking, Brake
20	105-1217	1	Decal				

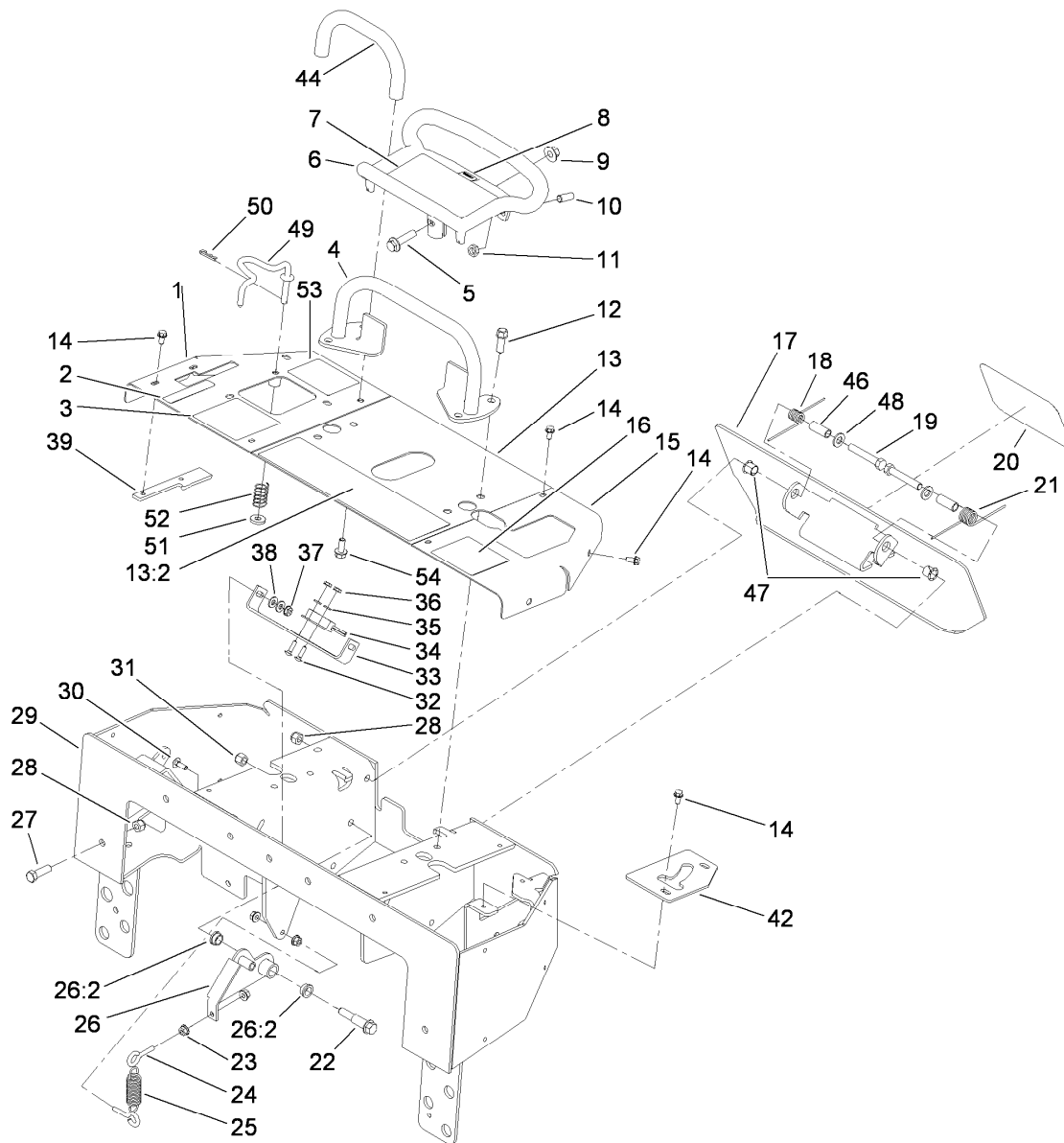

Control Panel Assembly (continued)

<i>Ref.</i>	<i>Part Number</i>	<i>Qty.</i>	<i>Description</i>
42	112-2749-01	1	Plate-Stop
44	112-2620	1	Bar-Reference
46	114-1337	2	Spacer-Spring
47	256-257	2	Bushing-Nyliner
48	3256-24	2	Washer-Flat
49	115-4580	1	Rod-Interlock

<i>Ref.</i>	<i>Part Number</i>	<i>Qty.</i>	<i>Description</i>
50	3290-307	1	Pin-Hair
51	88-7200	1	Washer-Flat
52	85-6750	1	Spring-Control
53	115-4862	1	Decal-Loader Lock
54	3234-5	2	Screw-HHF

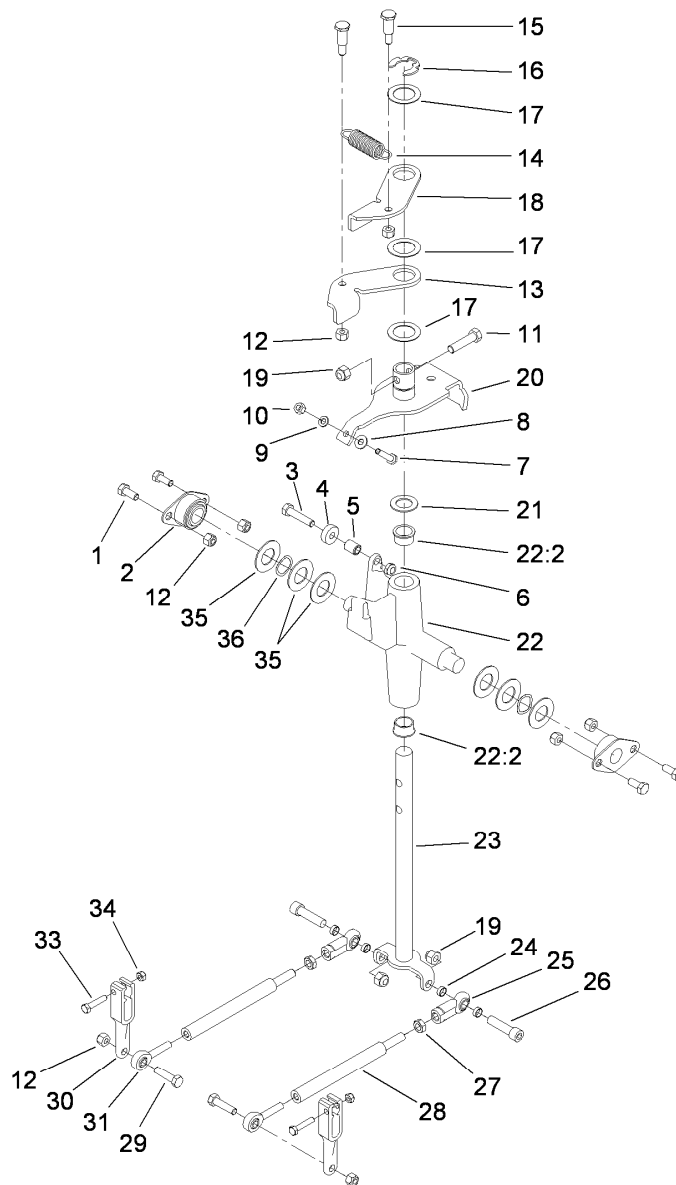

Traction Control Assembly

Ref.	Part Number	Qty.	Description	Ref.	Part Number	Qty.	Description
1	322-3	4	Screw-HH	19	3296-39	3	Nut-Lock, NI
2	68-2970	2	Bushing	20	112-2783	1	Lever-Pivot
3	322-7	1	Screw-HH	21	257-8	1	Washer-Thrust
4	251-259	1	Bearing-Ball	22	106-5737	1	Control Support ASM
5	88-7450	1	Spacer-Lever, Control	22:2	256-252	2	Bearing-Flange
6	3296-47	1	Nut-Lock, NI	23	117-6335	1	Rod-Drive
7	114-0282	1	Screw-HH	24	117-9915	4	Spacer
8	3256-22	1	Washer-Flat	25	103-1167	2	Joint-Ball End, LH
9	3253-3	1	Washer-Lock	26	3274-2	2	Screw-HSH
10	3217-5	1	Nut-Hex	27	3220-16	2	Nut-Jam, LH
11	323-8	1	Screw-HH	28	117-9900	2	Rod-Linkage
12	3296-29	8	Nut-Lock, NI	29	322-6	2	Screw-HH
13	98-8407	1	Lever-Return, RH	30	117-3964-03	2	Arm-Control, Pump
14	108-4724	1	Spring-Extension	31	117-9969	2	Bearing-Rod End, RH
15	63-2650	2	Screw-Shoulder	33	33113-030	2	Screw-HH
16	32151-91	1	Ring-Retaining	34	33023-00	2	Nut-Lock
17	108-9743	3	Washer-Plain	35	3256-39	2	Washer-Flat
18	98-8408	1	Lever-Return, LH	36	95-3703	2	Washer-Spring, Wave

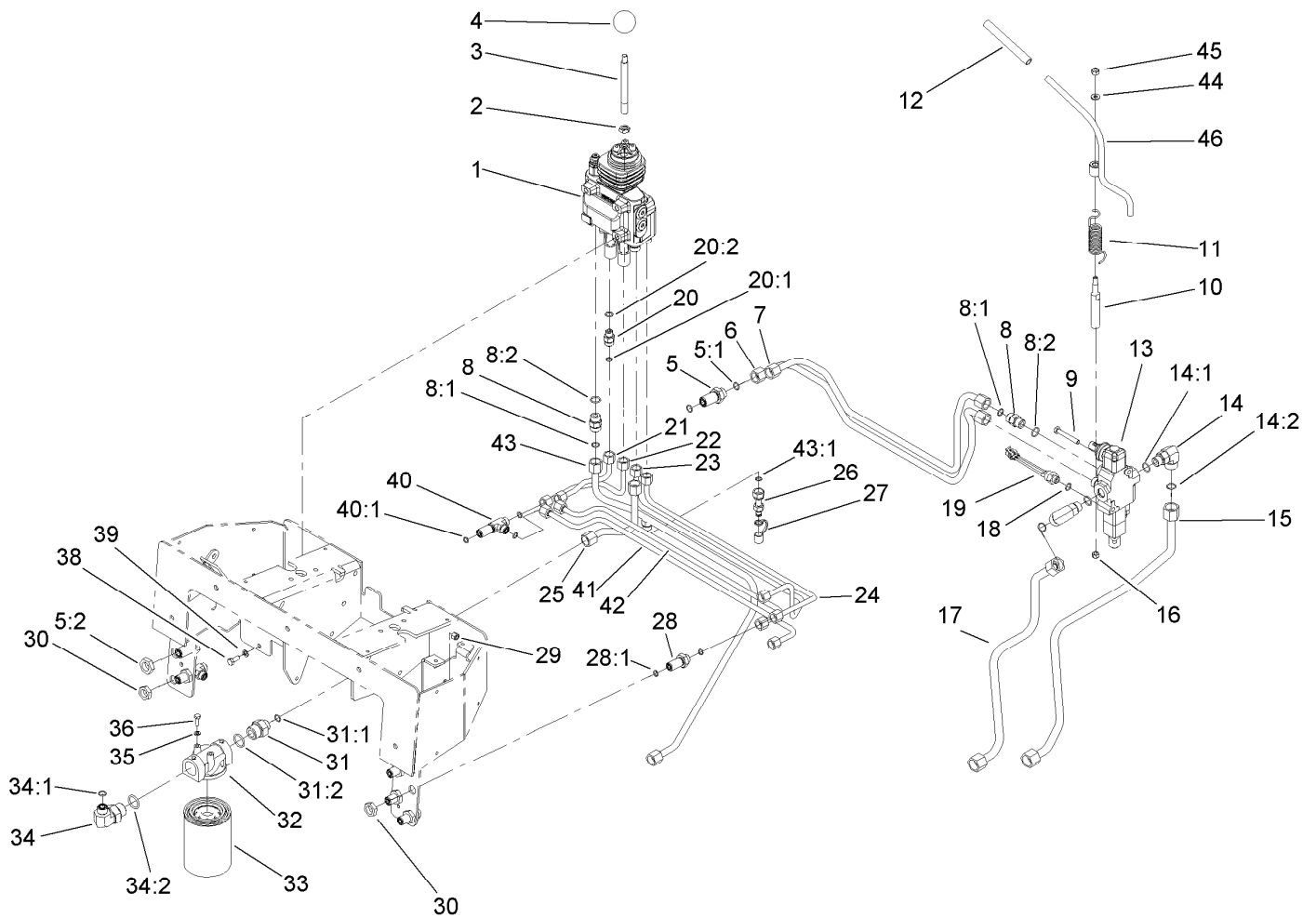

Principal Hydraulic Assembly

Ref.	Part Number	Qty.	Description	Ref.	Part Number	Qty.	Description
1	106-9307	1	2 Spool Valve ASM	20:2	237-42	1	O-Ring
2	51-2070	1	Nut	21	106-9315	1	HYD Tube ASM
3	108-4675	1	Shaft-Handle, Loader	22	106-9313	1	HYD Tube ASM
4	233-21	1	Knob	23	106-9312	1	HYD Tube ASM
5	340-161	2	Fitting-Bulkhead	24	106-9314	1	HYD Tube ASM
5:1	237-30	2	O-Ring	25	106-9385	1	HYD Tube ASM
5:2	340-127	1	Nut-Bulkhead	26	86-5480	1	Nipple-Test
6	106-9310	1	HYD Tube ASM	27	354-79	1	Cap-Dust
7	106-9311	1	HYD Tube ASM	28	340-71	4	Fitting-Straight, Bulkhead
8	340-4	4	Fitting-HYD, Straight	28:1	237-22	2	O-Ring
8:1	237-30	1	O-Ring	29	3296-29	2	Nut-Lock, NI
8:2	237-79	1	O-Ring	30	340-70	6	Nut-Lock
9	322-11	2	Screw-HH	31	100-4240	1	Fitting-Adapter
10	104-2827	1	Spacer-Hiflo	31:1	237-30	1	O-Ring
11	112-2738	1	Spring-Torsion	31:2	237-81	1	O-Ring
12	112-2605	1	Grip-Rubber	32	92-5821	1	Head-Filter
13	104-2831	1	1 Spool Valve ASM	33	86-3010	2	Filter-Oil
14	340-153	2	Fitting-Elbow, 90 DEG	34	340-131	1	Fitting-HYD, 90 DEG
14:1	237-79	1	O-Ring	34:1	237-30	1	O-Ring
14:2	237-151	1	O-Ring	34:2	237-81	1	O-Ring
15	106-9309	1	HYD Tube ASM	35	3253-3	2	Washer-Lock
16	48-7740	1	Screw	36	321-4	2	Screw-HH
17	104-5707	1	HYD Tube ASM	38	322-4	3	Screw-HH
18	237-42	1	O-Ring	39	3253-4	3	Washer-Lock
19	72-4310	1	Switch-Ball	40	340-68	2	Fitting-Tee, Bulkhead
20	340-2	4	Fitting-HYD, Straight	40:1	237-22	3	O-Ring
20:1	237-22	1	O-Ring	41	106-9316	1	HYD Tube ASM
				42	106-9317	1	HYD Tube ASM

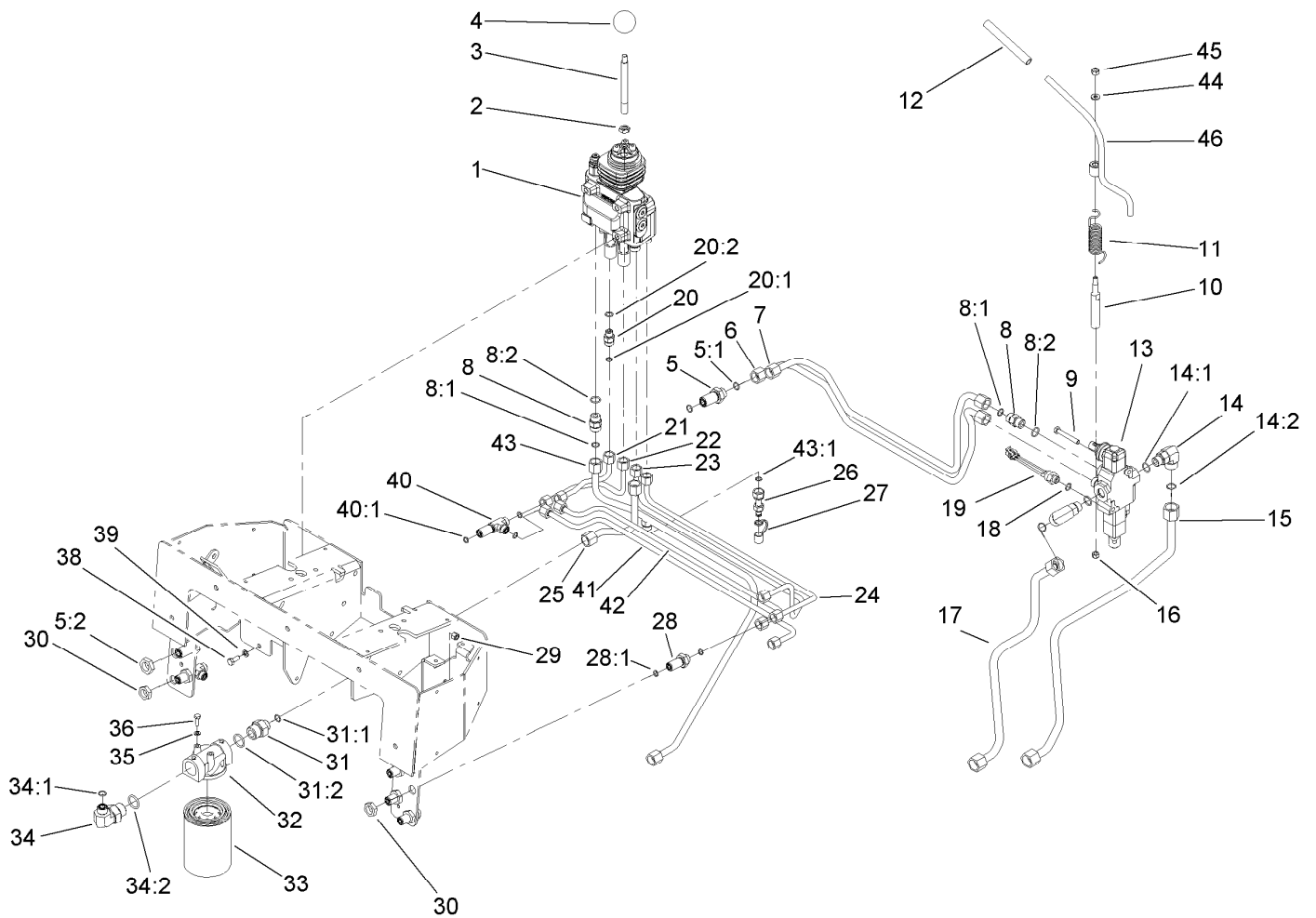

Principal Hydraulic Assembly (continued)

<i>Ref.</i>	<i>Part Number</i>	<i>Qty.</i>	<i>Description</i>
43	106-9387	1	HYD Tube ASM
43:1	237-22	1	O-Ring
44	3256-16	1	Washer-Flat

<i>Ref.</i>	<i>Part Number</i>	<i>Qty.</i>	<i>Description</i>
45	3296-42	1	Nut-Lock, NI
46	112-2739	1	Lever-Auxiliary

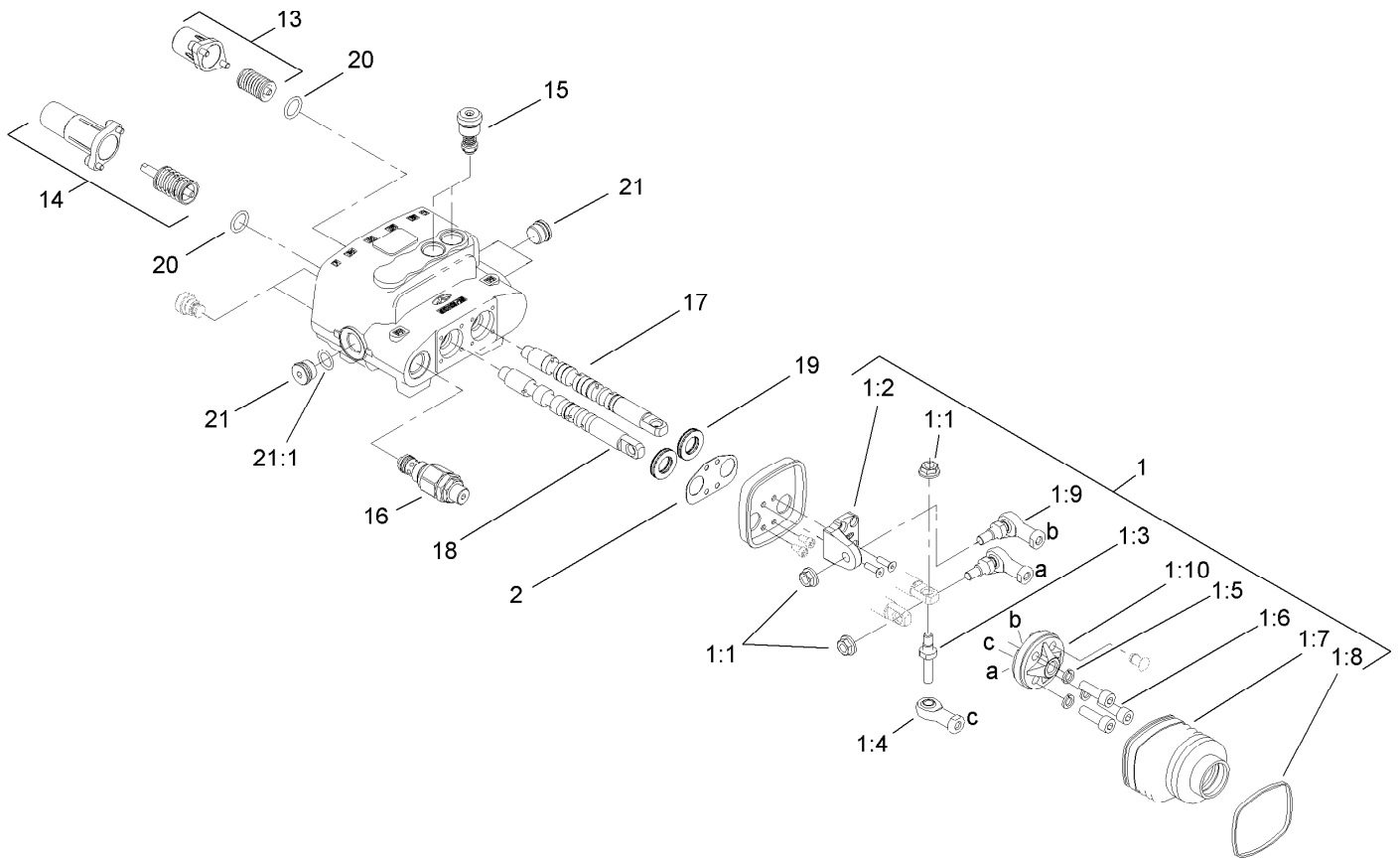

Two Spool Valve Assembly No. 106-9307

Ref.	Part Number	Qty.	Description
1	106-7724	1	Joystick Kit
1:1	98-0668	3	Nut
1:2	106-7726	1	Pivot-Joystick
1:3	106-7727	1	Pin-Joystick
1:4	106-7728	1	End-Rod
1:5	42-9850	3	Washer-Lock, Spring
1:6	98-5828	3	Screw-HSH
1:7	106-7729	1	Bellow-Rubber
1:8	3290-379	1	Tie-Cable
1:9	106-7730	2	Joint-Joystick
1:10	106-7731	1	Holder-Articulated
2	106-7725	1	Seal-Joystick
13	106-7732	1	Valve Spring Kit
14	106-7733	1	Detent Spring Kit
15	106-7734	2	Valve-Relief
16	106-7735	1	Valve-Relief, Main
17	106-7736	1	Spool-Valve
18	106-7737	1	Spool-Valve
19	106-7738	2	Seal-Valve, Spool
20	106-7719	2	Seal-Valve
21	353-988	3	Plug-Hex
21:1	237-79	1	O-Ring

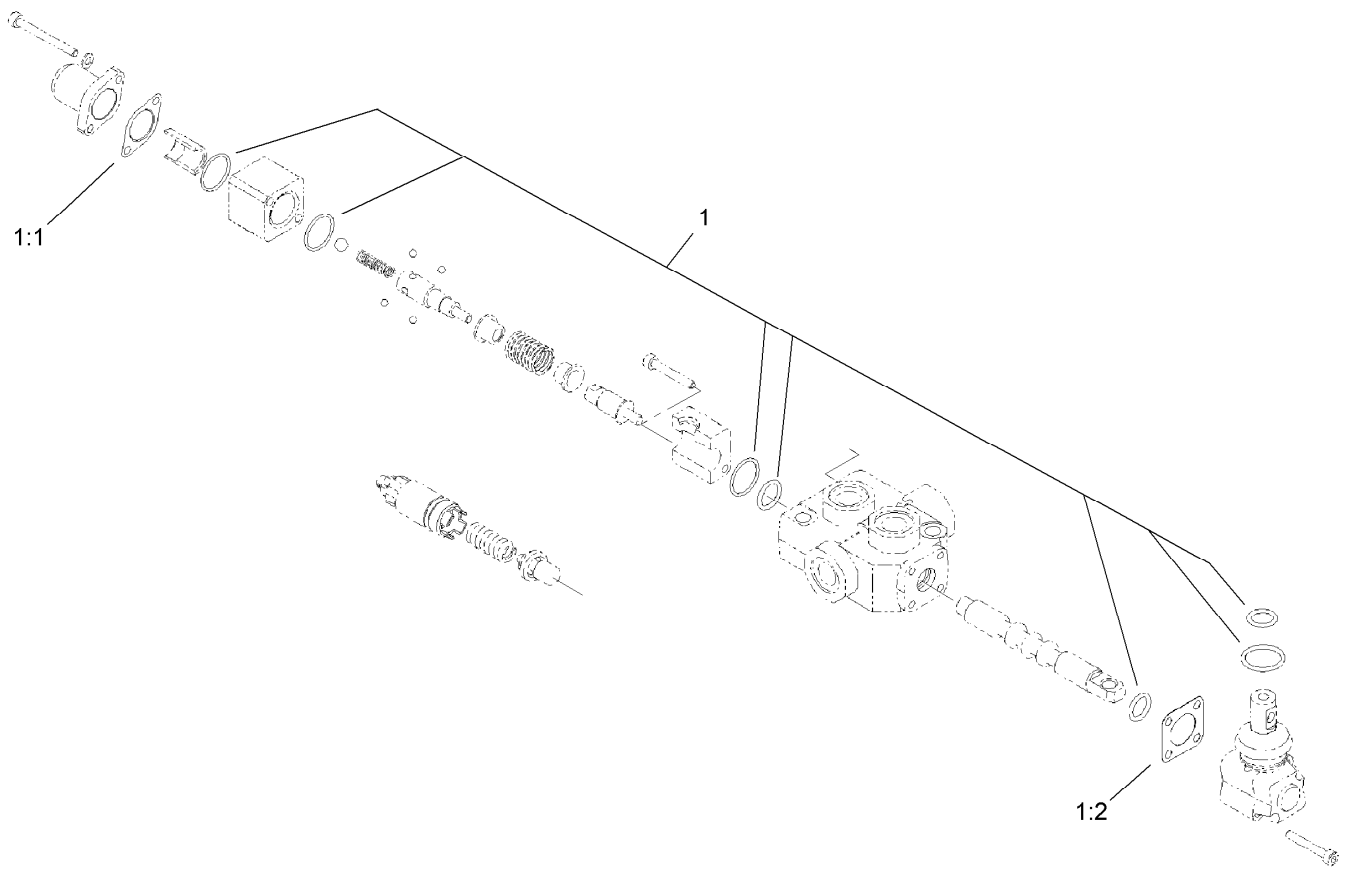

One Spool Valve Assembly No. 104-2831

<i>Ref.</i>	<i>Part Number</i>	<i>Qty.</i>	<i>Description</i>
1	99-4390	1	Seal Kit
1:1	99-3074	4	Gasket
1:2	99-3075	8	Gasket

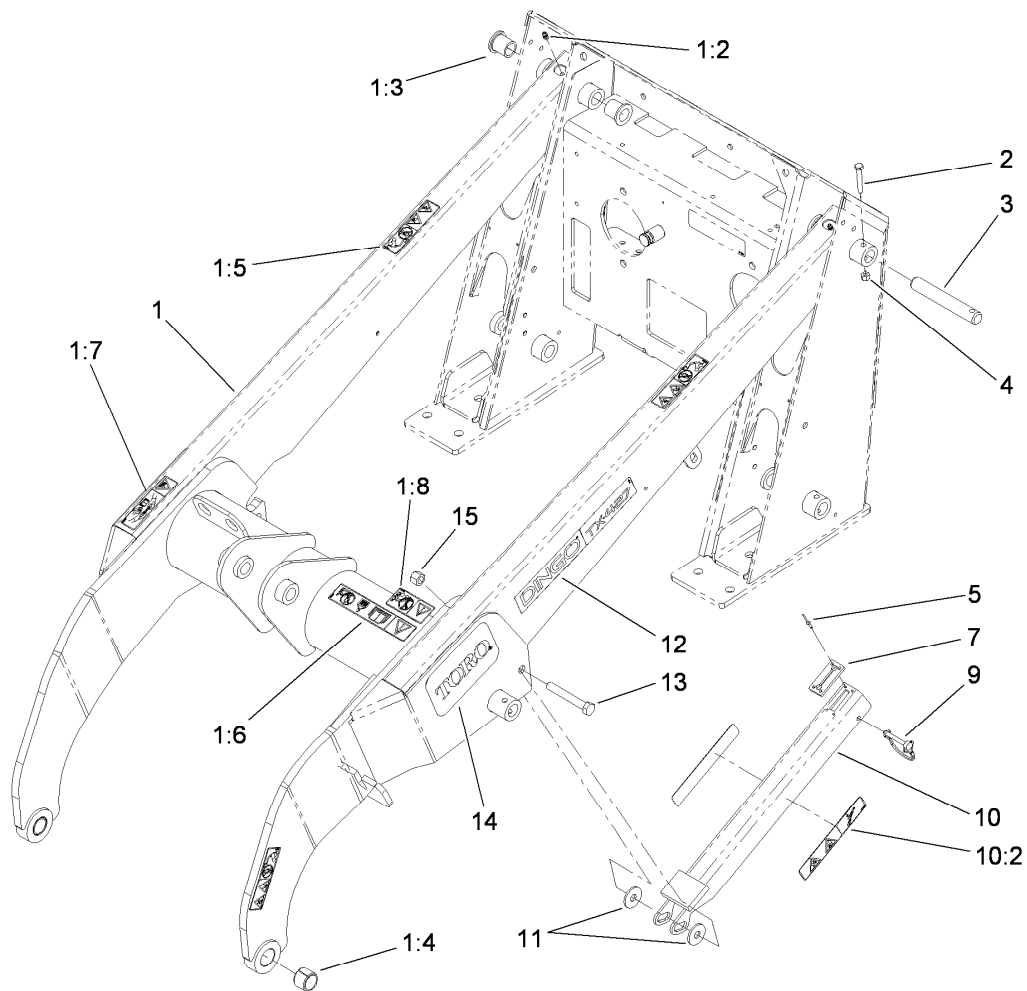

Loader Arm Assembly

<i>Ref.</i>	<i>Part Number</i>	<i>Qty.</i>	<i>Description</i>
1	108-4638	1	Loader Arm ASM
1:2	302-5	2	Fitting-Grease
1:3	95-3577	4	Bushing
1:4	98-4871	2	Bushing-Tension
1:5	100-8821	4	Decal-Warning, Pinch
1:6	115-4856	1	Decal-Caution
1:7	115-4855	1	Decal-Caution
1:8	100-8822	1	Decal-No Rider
2	322-10	7	Screw-HH
3	104-2849	7	Pin-Locking
4	3296-29	7	Nut-Lock, NI
5	95-1687	4	Rivet
7	98-0083	1	Stop-Rubber
9	112-2583	1	Pin-Locking
10	108-4639	1	Locking Arm ASM
10:2	115-4858	2	Decal-Danger
11	68-1440	2	Washer-Rubber
12	115-4867	2	Decal
13	325-14	1	Screw-HH
14	105-1217	2	Decal
15	3296-23	1	Nut-Lock, NI

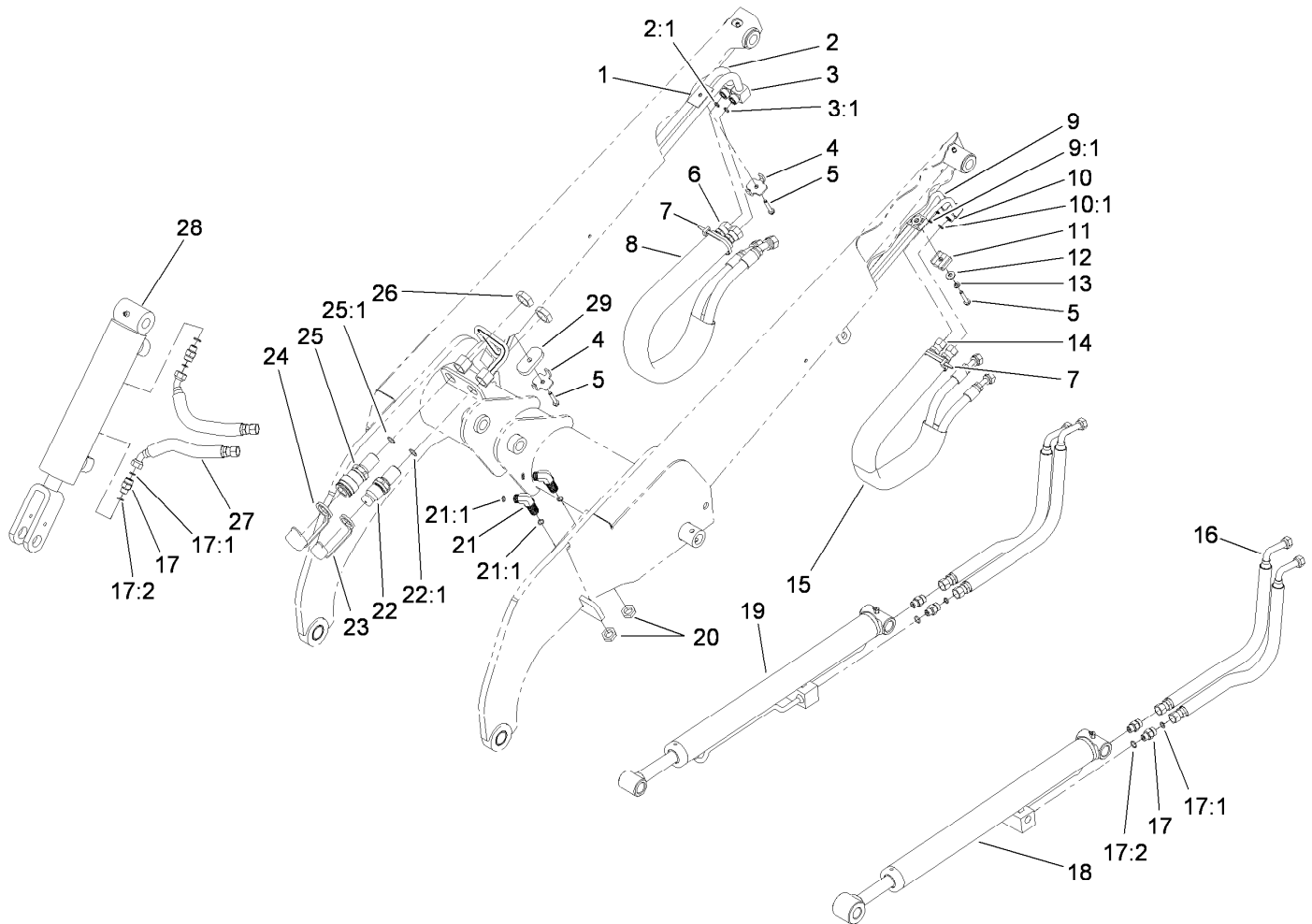

Loader Arm Hydraulic Assembly

Ref.	Part Number	Qty.	Description	Ref.	Part Number	Qty.	Description
1	106-9366	1	Spacer-Hardline	17	340-2	6	Fitting-HYD, Straight
2	108-6319	1	HYD Tube ASM	17:1	237-22	1	O-Ring
2:1	237-22	1	O-Ring	17:2	237-42	1	O-Ring
3	112-2563	1	HYD Tube ASM	18	104-6267	1	LH Lift Cylinder ASM
3:1	237-22	1	O-Ring	19	104-6269	1	RH Lift Cylinder ASM
4	98-0237	2	Plate-Clamp, Tube	20	340-70	2	Nut-Lock
5	94-2691	3	Screw-HWH	21	340-154	2	Union-Bulkhead
6	98-0242	2	HYD Hose ASM	21:1	237-22	2	O-Ring
7	3290-378	2	Tie-Cable	22	105-8395	1	Bulkhead Nipple ASM
8	100-6128	1	Sleeve-Protective	22:1	237-65	1	O-Ring
9	106-9364	1	HYD Tube ASM	22:2	100-6120	1	Seal Kit ●
9:1	237-22	1	O-Ring	23	100-8815	1	Cap-Dust, Nipple
10	106-9365	1	HYD Tube ASM	24	100-8816	1	Cap-Dust, Coupler
10:1	237-22	1	O-Ring	25	105-8394	1	Bulkhead Coupler ASM
11	56-7973	2	Clamp-Tube	25:1	237-65	1	O-Ring
12	3256-2	1	Washer-Flat	26	340-74	2	Nut-Lock, Bulkhead
13	3253-3	1	Washer-Lock	27	98-0207	2	HYD Hose ASM
14	98-0213	2	HYD Hose ASM	28	105-8370	1	Tilt Cylinder ASM
15	100-6127	1	Sleeve-Protective	29	112-2565	1	Plate-Hardline
16	98-0216	4	HYD Hose ASM				

● Not illustrated

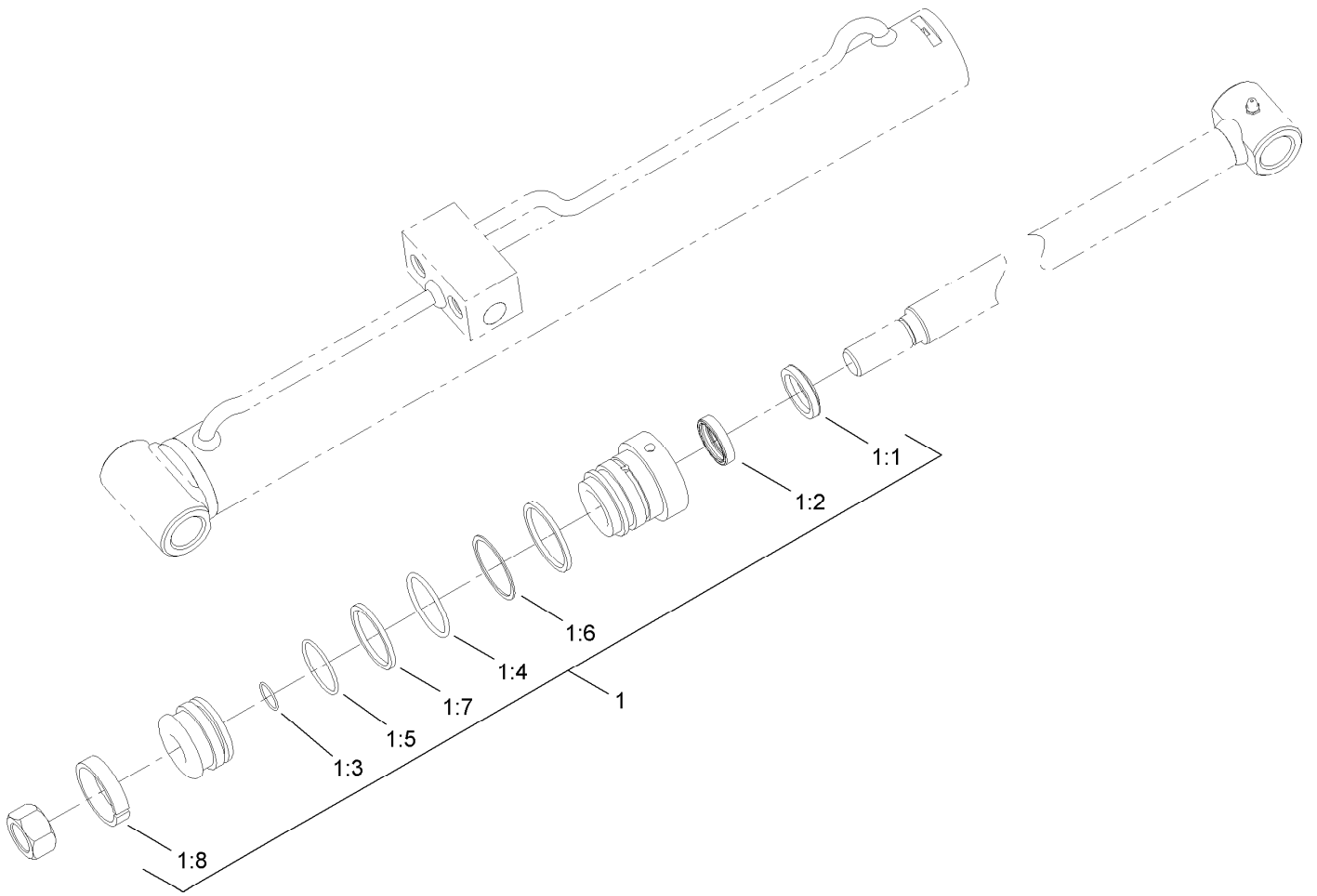

Left Hand Hydraulic Lift Cylinder Assembly No. 104-6267

<i>Ref.</i>	<i>Part Number</i>	<i>Qty.</i>	<i>Description</i>
1	104-6268	1	Seal Kit
1:1		1	Wiper ●
1:2		1	Seal ●
1:3		1	O-Ring ●
1:4		1	O-Ring ●
1:5		1	O-Ring ●
1:6		1	Back-Up ●
1:7		1	Seal ●
1:8		1	Wear Ring ●

● Not serviced separately

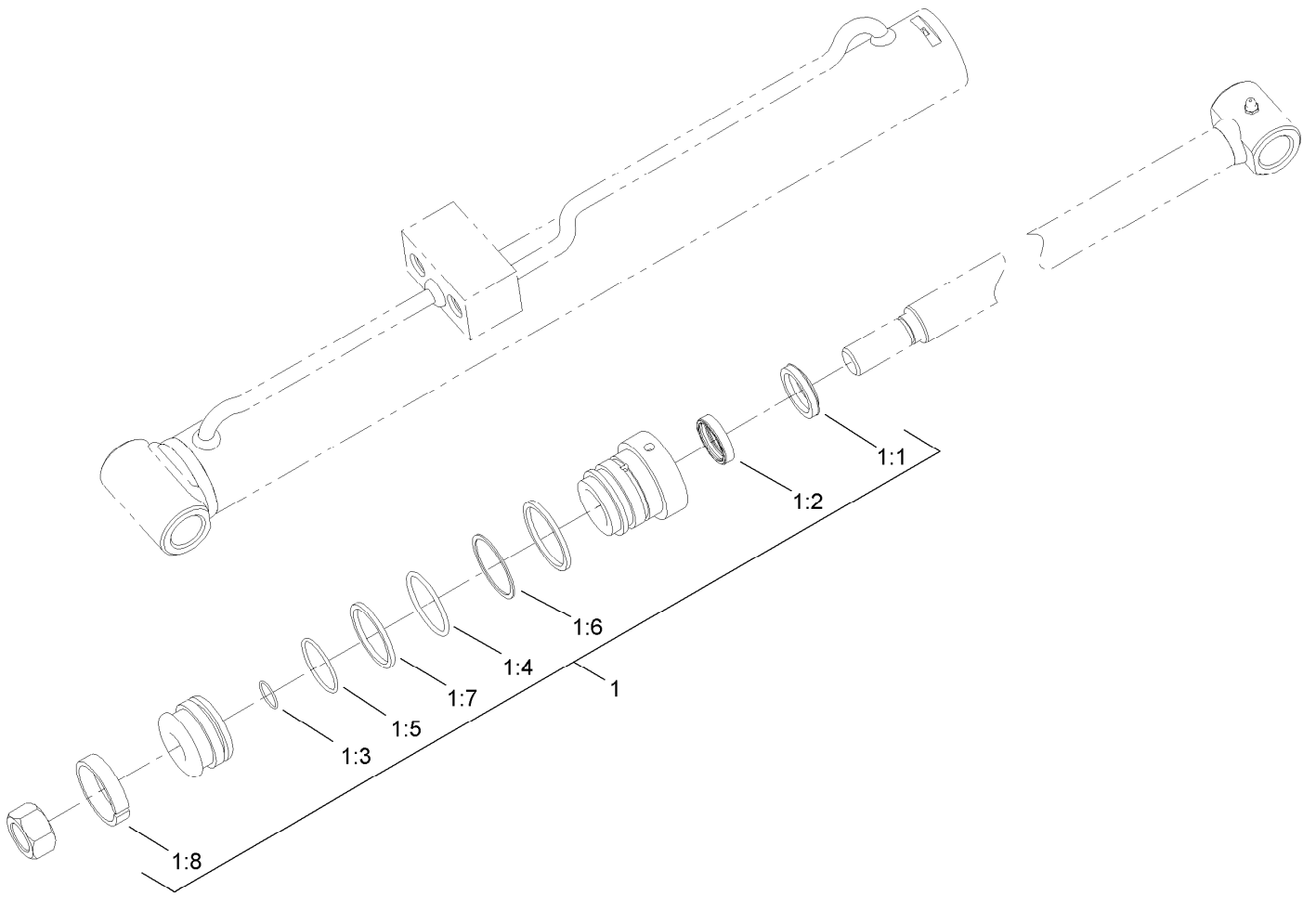

Right Hand Hydraulic Lift Cylinder Assembly No. 104-6269

<i>Ref.</i>	<i>Part Number</i>	<i>Qty.</i>	<i>Description</i>
1	104-6268	1	Seal Kit
1:1		1	Wiper ●
1:2		1	Seal ●
1:3		1	O-Ring ●
1:4		1	O-Ring ●
1:5		1	O-Ring ●
1:6		1	Back-Up ●
1:7		1	Seal ●
1:8		1	Wear Ring ●

● Not serviced separately

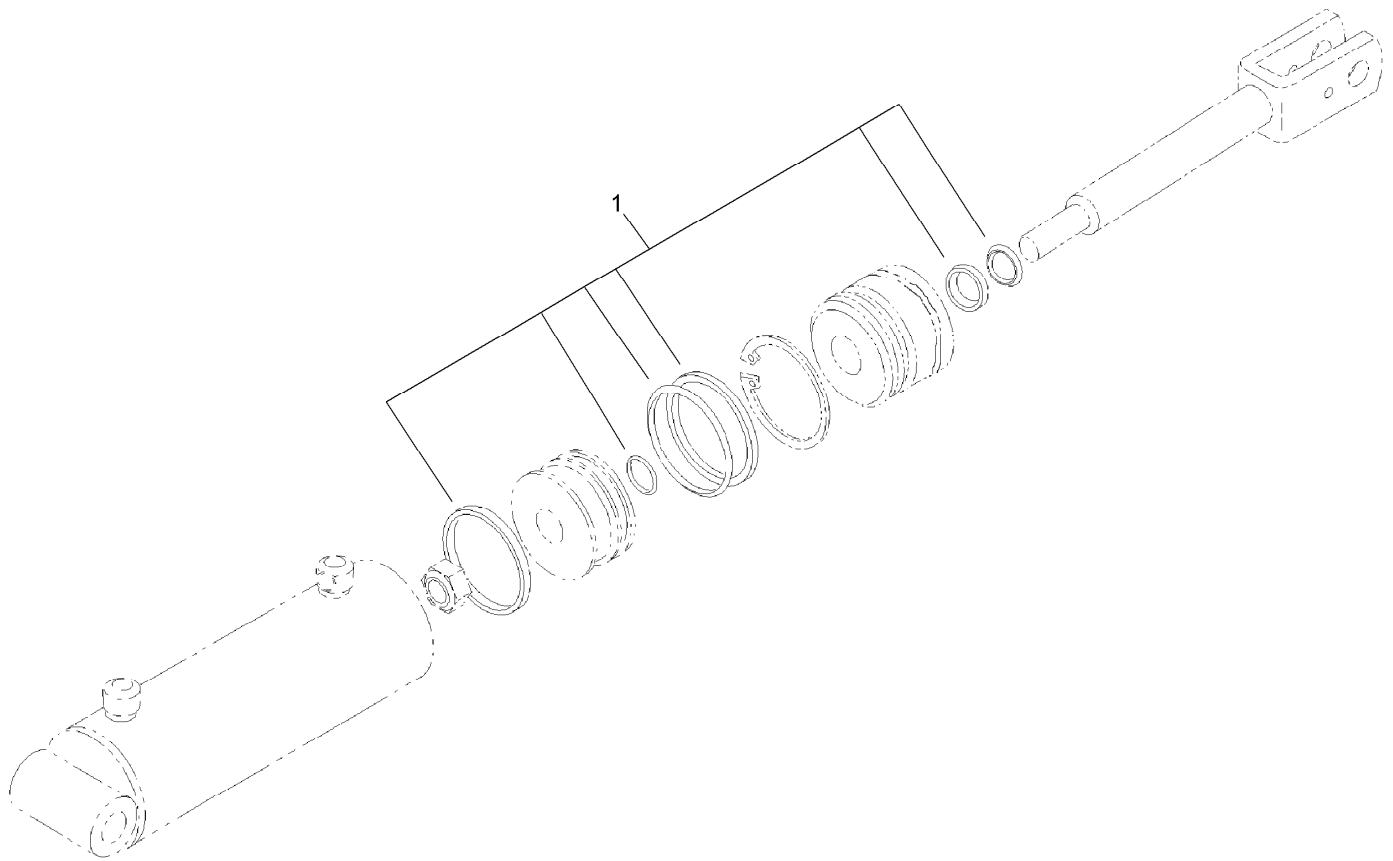

Hydraulic Cylinder Assembly No. 105-8370

<i>Ref.</i>	<i>Part Number</i>	<i>Qty.</i>	<i>Description</i>
1	106-7567	1	Seal Kit

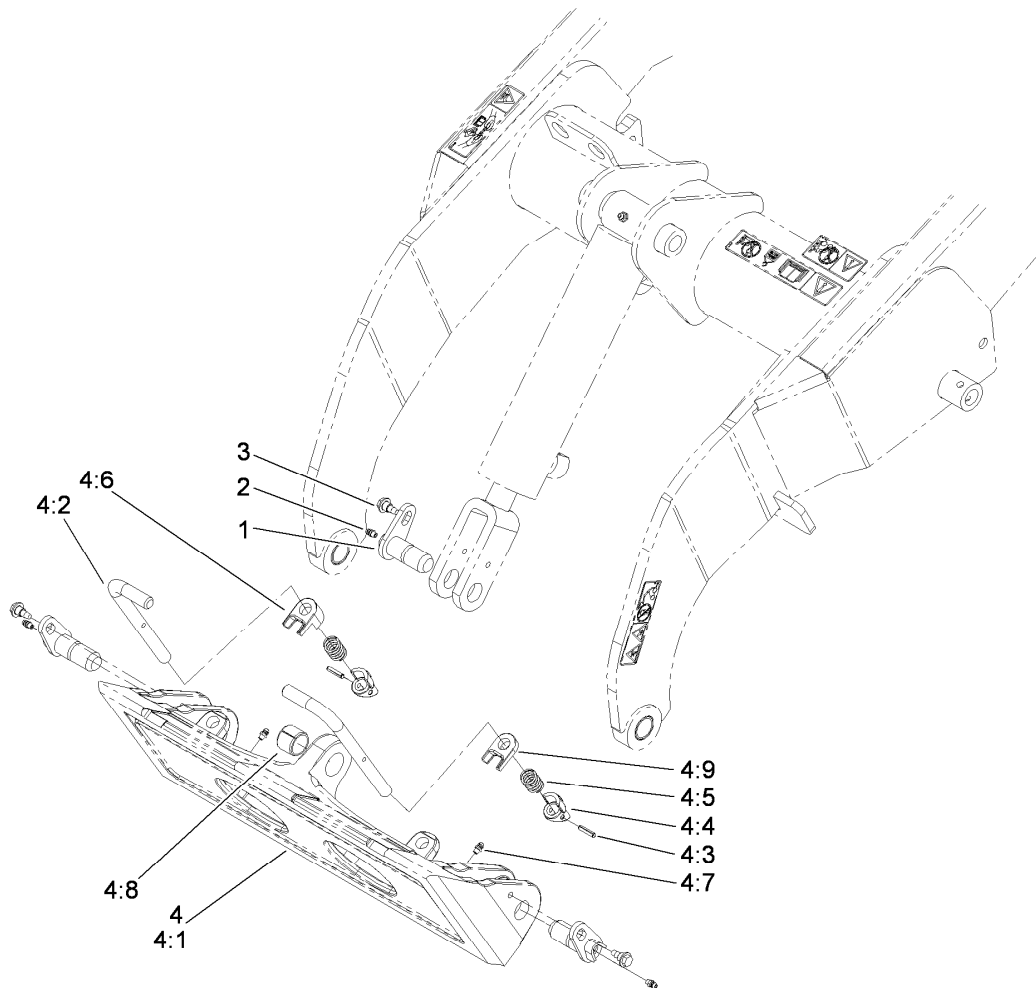

Quick Attach Assembly

<i>Ref.</i>	<i>Part Number</i>	<i>Qty.</i>	<i>Description</i>
1	112-2609	3	Pin-Pivot
2	302-5	3	Fitting-Grease
3	99-5105	3	Bolt-Shoulder
4	115-0788	1	Quick Attach ASM
4:1	115-0774-03	1	Mount-Qtach
4:2	105-8367	2	Pin-Locking
4:3	3285-1	2	Pin-Grooved
4:4	105-0246	2	Cam
4:5	98-4694	2	Spring-Compression
4:6	104-5909	1	Stop-RH
4:7	302-5	2	Fitting-Grease
4:8	98-4871	1	Bushing-Tension
4:9	104-5903	1	Stop-LH

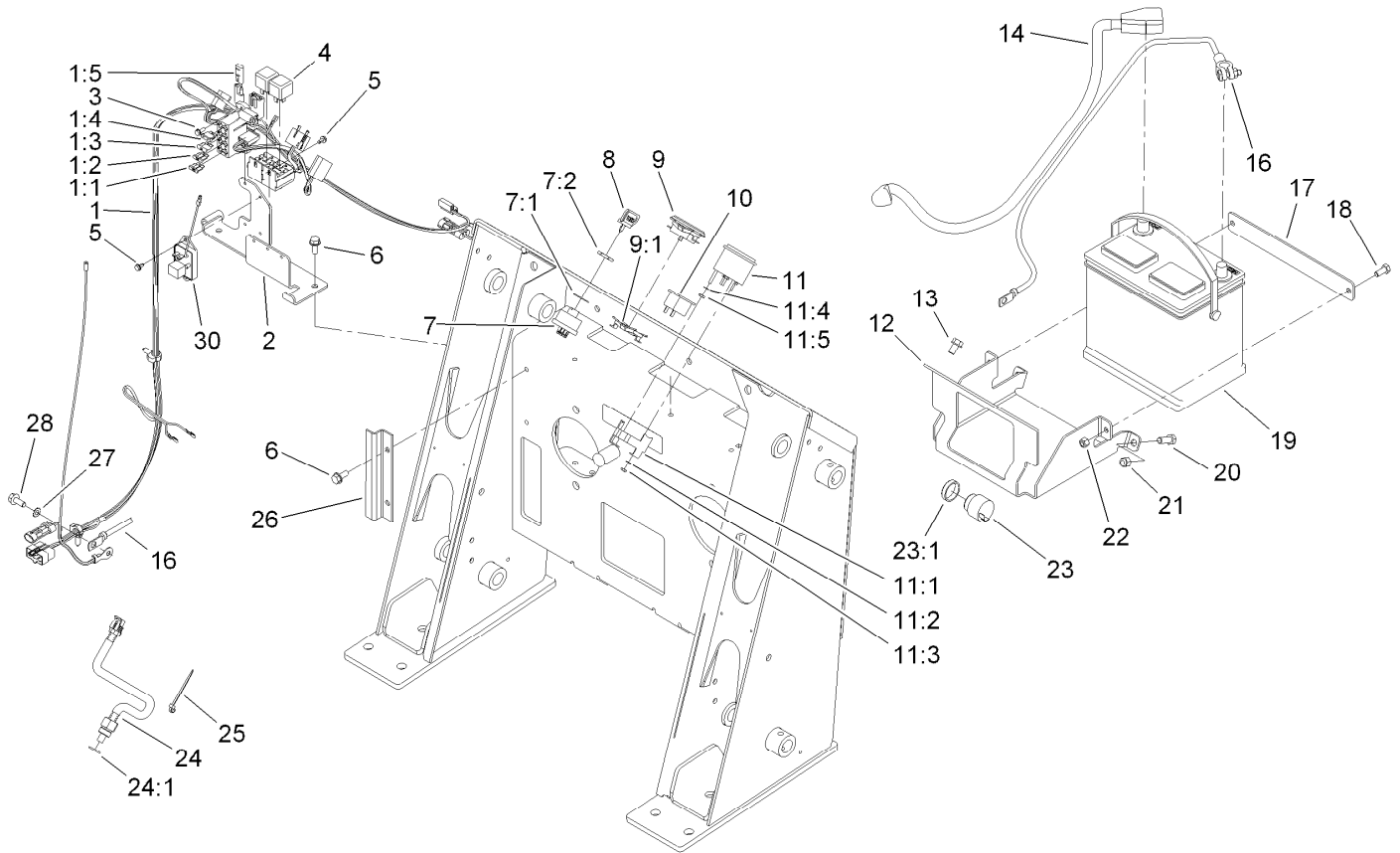

Electrical System Assembly

Ref.	Part Number	Qty.	Description	Ref.	Part Number	Qty.	Description
1	117-1732	1	Harness-Wire	11:4	3255-24	3	Washer-Lock / EXT
1:1	109103	1	Fuse-Blade, 30 Amp	11:5	3217-16	3	Nut-Hex
1:2	109102	1	Fuse-Blade, 25 Amp	12	106-9390-01	1	Tray-Mounting, Battery
1:3	218-578	1	Fuse-Blade, 10 Amp	13	32144-69	2	Screw-HWHTF
1:4	109355	2	Fuse-Blade, 15 Amp	14	106-5707	1	Cable-Battery, Positive
1:5	116-0053	1	Cap-Plug	16	106-5708	1	Cable-Battery, Negative
2	117-1735-03	1	Bracket-Fuse/Relay	17	105-0371-01	1	Clamp-Battery
3	32104-4	2	Screw	18	322-3	2	Screw-HH
4	98-7249	2	Relay	19	104-9979	1	Battery
5	104-2065	4	Screw-HWH	20	323-6	2	Screw-HH
6	32144-11	4	Screw-HWHTF	21	3296-39	2	Nut-Lock, NI
7	88-9830	1	Key Switch ASM	22	3296-29	2	Nut-Lock, NI
7:1	3254-5	1	Washer-Tooth, Internal	23	80-9330	1	Audio Alarm ASM
7:2	218-461	1	Nut-HH	23:1	104-5107	1	Nut-Plastic, Knurled
8	63-8360	3	Key-Ignition (W/Shield)	24	98-2765	1	Sensor-Temperature
9	104-7427	1	Inductive Hourmeter ASM	24:1	237-79	1	O-Ring
9:1	104-4234	1	Clip-Mounting	25	3290-381	3	Tie-Cable
10	104-2839	1	Light-Temp, Oil	26	100-6117-01	1	Shield-Wiring
11	66-2940	1	Gauge-Fuel	27	3255-8	1	Washer-Lock
11:1	100-6147	1	Bracket-Mounting, Gauge	28	33104-016	1	Screw-HHF
11:2	3254-1	2	Washer-Lock, Int	30	99-7422	1	Module-Ignition Delay
11:3	3217-27	2	Nut-Hex				

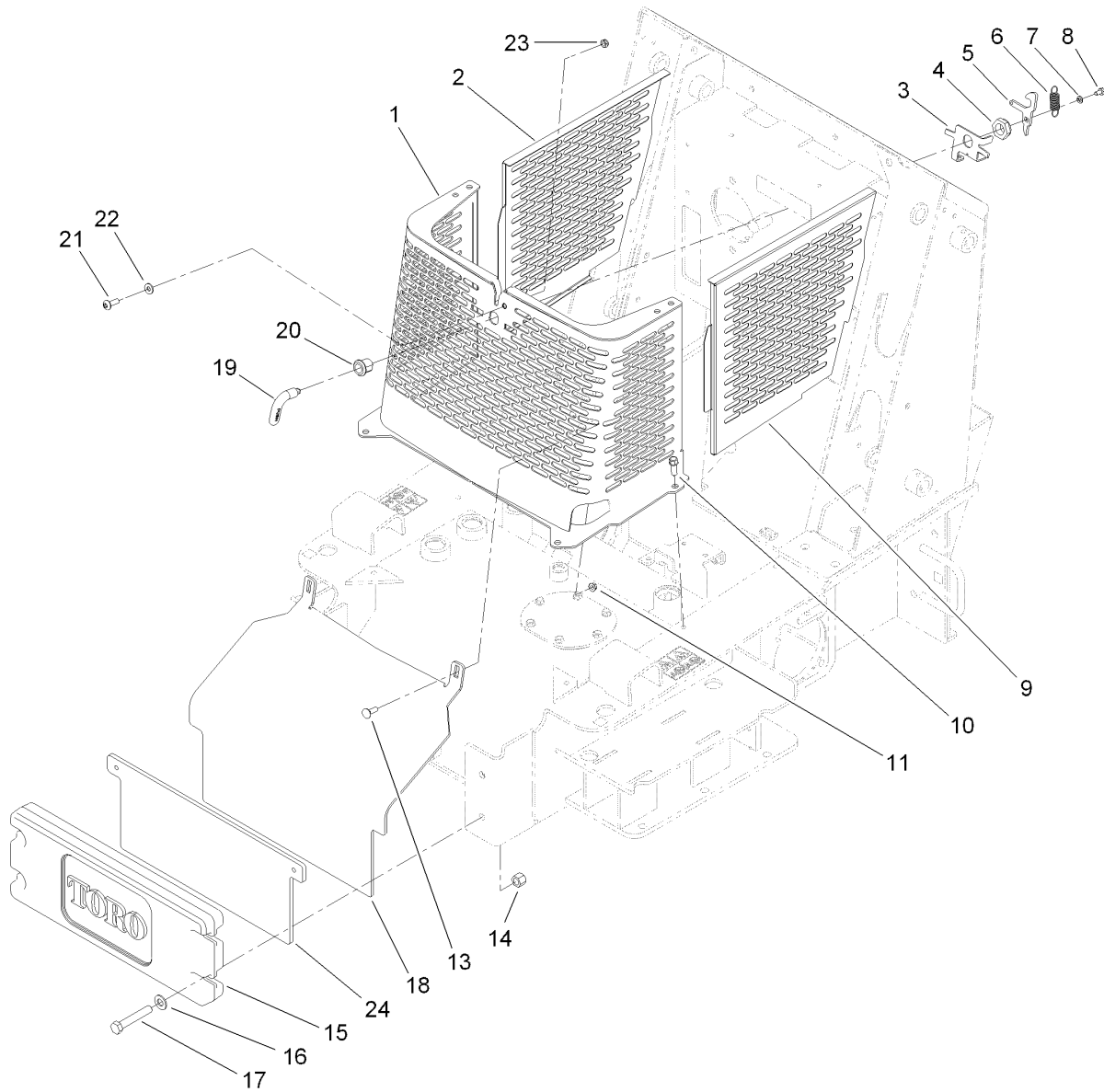

Grill Assembly

<i>Ref.</i>	<i>Part Number</i>	<i>Qty.</i>	<i>Description</i>	<i>Ref.</i>	<i>Part Number</i>	<i>Qty.</i>	<i>Description</i>
1	117-9998-03	1	Grill	14	3296-23	4	Nut-Lock, NI
2	106-5727-03	1	Panel-Side, RH	15	99-6166-01	1	Counterweight-Front
3	106-5729-03	1	Bracket-Latch	16	3256-26	4	Washer-Flat
4	3296-60	1	Nut-Lock, NI	17	325-12	4	Screw-HH
5	106-5728	1	Cam-Latch	18	117-9994-03	1	Plate-Front
6	104-0869	1	Spring-Brake	19	108-5639	1	Handle-Latch
7	3253-3	1	Washer-Lock	20	106-9335	1	Housing-Latch
8	321-2	1	Screw-HH	21	107-8021	1	Screw-PTH
9	106-5726-03	1	Panel-Side, LH	22	3256-2	1	Washer-Flat
10	95-1726	4	Screw-Taptite	23	3296-47	1	Nut-Lock, NI
11	32128-20	2	Nut-HF	24	117-9995-03	1	Plate-Counterweight
13	3230-28	2	Screw-CARR				

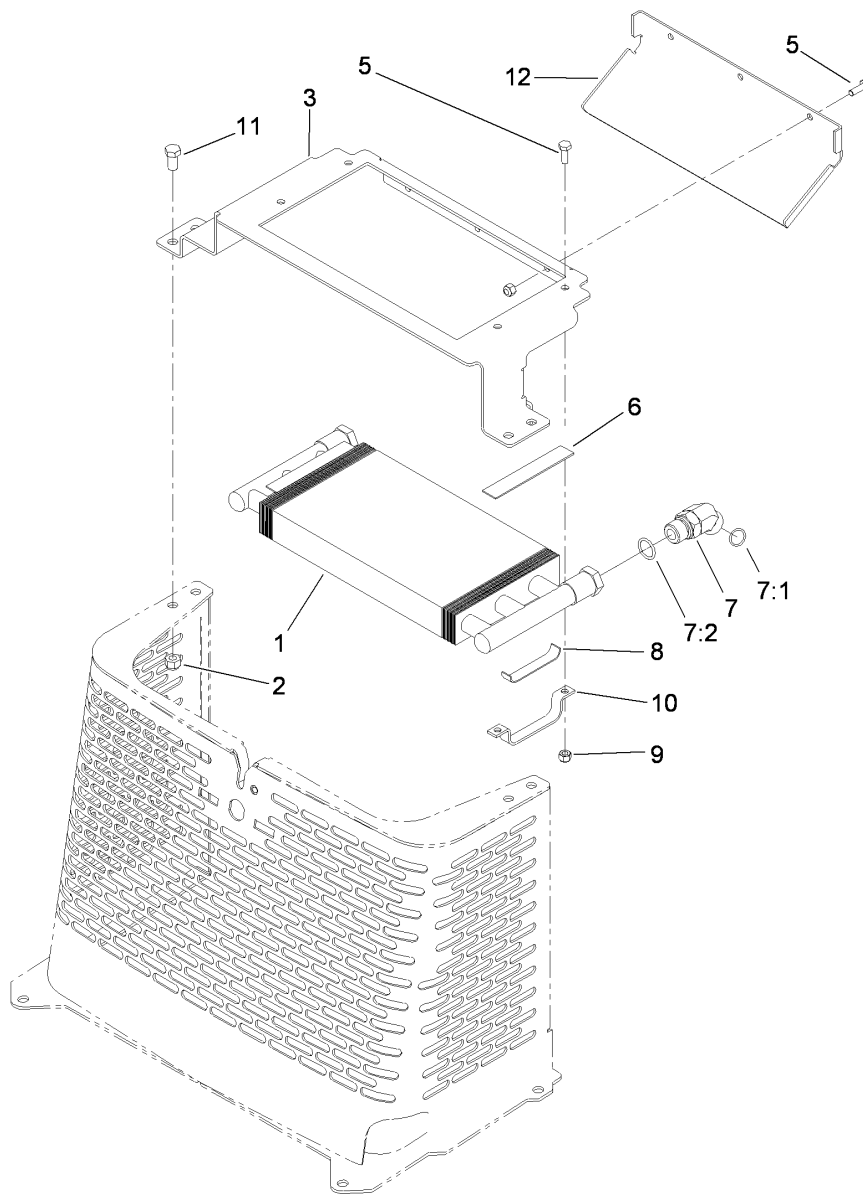

Hydraulic Oil Cooler Assembly

<i>Ref.</i>	<i>Part Number</i>	<i>Qty.</i>	<i>Description</i>
1	105-0352	1	Exchanger-Heat
2	3296-39	4	Nut-Lock, NI
3	120-5360-03	1	Bracket-Mounting, Cooler
5	321-4	7	Screw-HH
6	94-9566	2	Pad-Footrest
7	340-14	2	Fitting-HYD, 45 DEG
7:1	237-65	1	O-Ring
7:2	237-80	1	O-Ring
8	104-2816	2	Pad-Support
9	3296-42	7	Nut-Lock, NI
10	104-2803	2	Support-Cooler
11	3234-42	4	Screw-HHF
12	115-0798-03	1	Deflector-Cooler

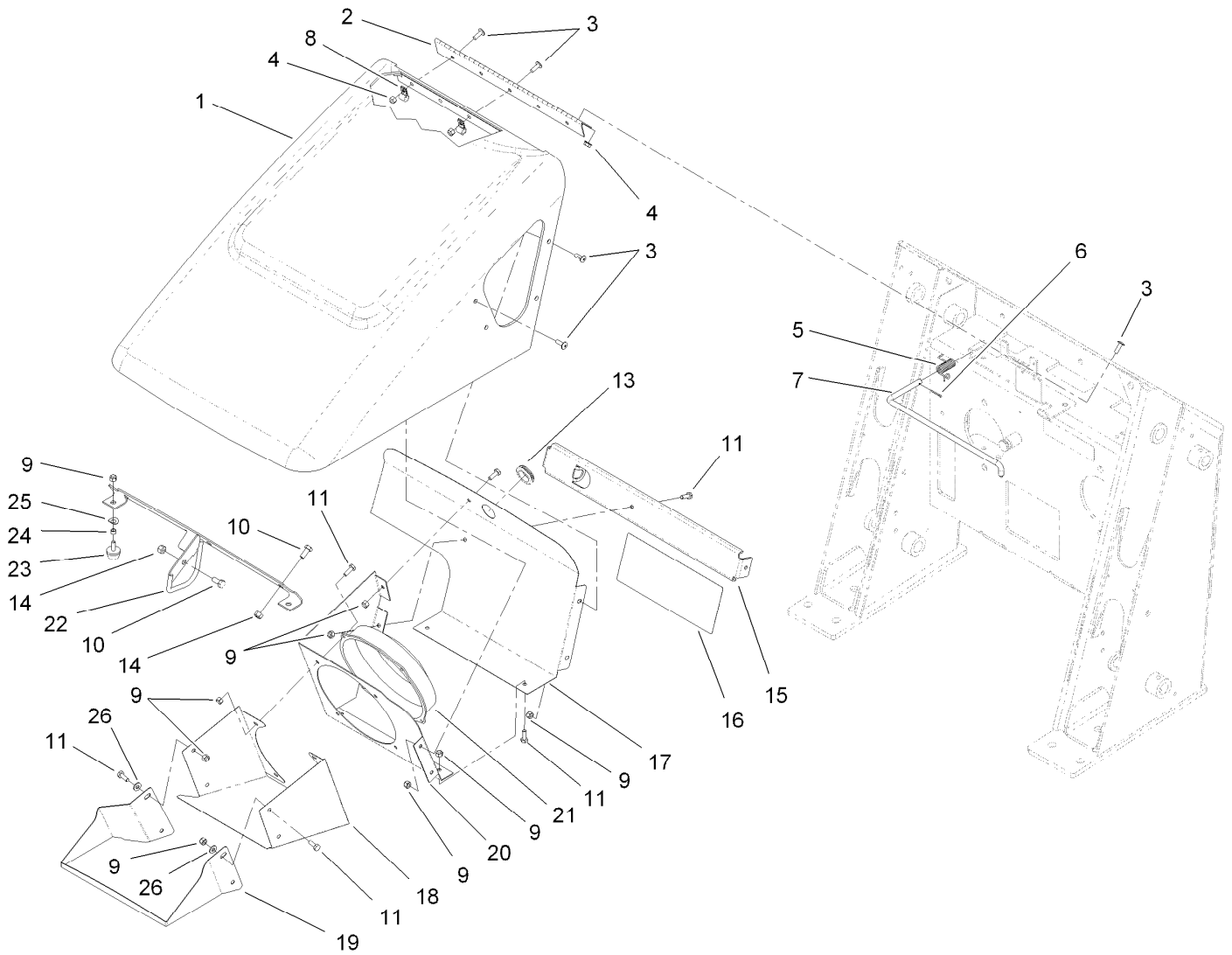

Hood Assembly

<i>Ref.</i>	<i>Part Number</i>	<i>Qty.</i>	<i>Description</i>	<i>Ref.</i>	<i>Part Number</i>	<i>Qty.</i>	<i>Description</i>
1	114-1363	1	Hood	15	115-4849-03	1	Bracket-Support, Hood
2	100-1284	1	Hinge-Hood	16	117-1806	1	Decal-Service
3	9114604	14	Screw-Head, Truss	17	114-8715-03	1	Bracket-Fan, Back
4	32128-33	6	Nut-HF	18	114-8711-03	1	Shroud-Fan
5	106-2584	1	Spring-Torsion	19	114-8712-03	1	Shroud-Fan, Front
6	3272-6	1	Pin-Cotter	20	114-8714-03	1	Bracket-Fan, Back
7	106-2554	1	Rod-Support, Hood	21	104-2809	1	Fan
8	2412-91	2	Clamp	22	117-1725-03	1	Latch-Rod
9	3296-42	22	Nut-Lock, NI	23	1-523420	2	Bumper
10	322-3	4	Screw-HH	24	106-9308	2	Spacer
11	321-4	12	Screw-HH	25	3290-301	2	Washer-Spring
13	240-5	1	Grommet	26	3256-22	2	Washer-Flat
14	3296-29	4	Nut-Lock, NI				

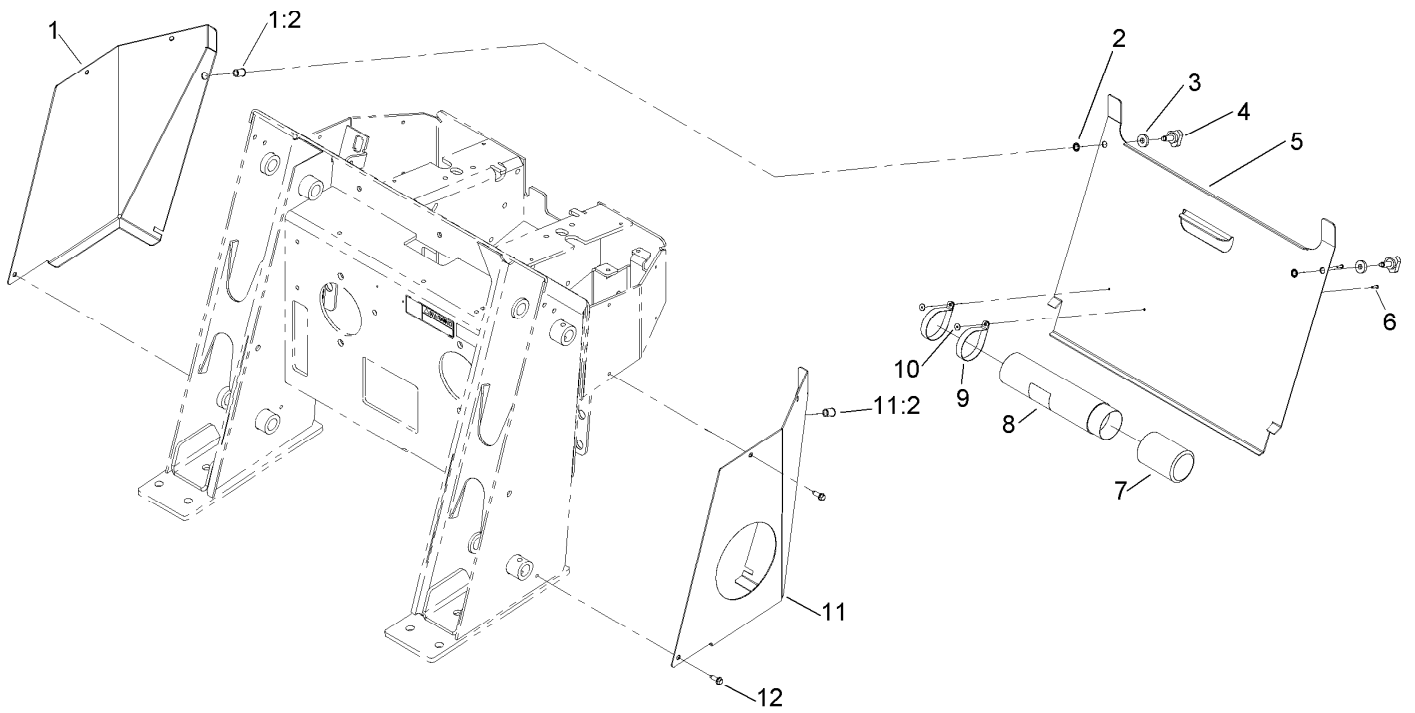

Rear Access Cover Assembly

<i>Ref.</i>	<i>Part Number</i>	<i>Qty.</i>	<i>Description</i>
1	106-9342	1	RH Rear Cover Support ASM
1:2	32148-9	1	Insert-Nut
2	32151-72	2	Ring-Retaining
3	106-0565	2	Washer-Rubber
4	95-9648	2	Knob
5	106-9339-01	1	Cover-Access, Rear
6	3269-17	2	Rivet-Pop
7	104-7048	1	Cap-Housing
8	104-7050	1	Tube-Manual
9	2412-120	2	Clamp-R
10	3269-10	2	Washer-Back
11	106-9343	1	LH Rear Cover Support ASM
11:2	32148-9	1	Insert-Nut
12	9266714	6	Screw-HWH

Attachments and Accessories

For 22322 TX 427 Wide Track Compact Utility Loader

Product Name	Model/Part
Light Kit.....	100-8840
Road Wheel Kit.....	106-7620
Reference Guide Kit	107-9310
Track-Aggressive Tread, Wide	108-9749
4 Cubic Foot Standard Bucket	22409
Loose Materials Bucket	22410
48in Hydraulic Blade.....	22414
Rotary Broom	22415
Bore Drive Head	22420
Rod And Reamer	22421
Multi-Purpose Tool.....	22423
Power Box Rake.....	22425
Stump Grinder	22429
Tree Forks	22438
Cement Bowl	22442
40in Tiller	22445
Snowthrower.....	22456
Crumber Kit	22464
Trencher Head.....	22470
High-Speed Trencher Head.....	22471
Trench Filler.....	22472
TX Platform.....	22475
Narrow Bucket.....	22520
Grapple Rake	22521
Auger Head	22805
Universal Swivel Auger Head	22806
Vibratory Plow	22911
Soil Cultivator	23101
Concrete Breaker	23135
TX Fit Up Kit	23162
Backhoe.....	23163
Adjustable Forks.....	23164
Leveler.....	23165
Spark Arrestor Screen	75-6880

Notes:

Notes:

Notes:



Count on it.