

# PARTS MANUAL



**STREET PRO  
MODEL SP1G  
CONCRETE SAW  
(HONDA GX200UT2QXC9  
GASOLINE ENGINE)**

Revision #2 (09/13/19)



THIS MANUAL MUST ACCOMPANY THE EQUIPMENT AT ALL TIMES.

PN: 38642

# PARTS FINDER

**Search Website  
by Part Number**



**Search Manual  
Library For Parts  
Manual & Lookup Part  
Numbers – Purchase  
or Request Quote**

**Search Manuals**

Enter your information to help us find the right parts manual for your machine.

\* Brand:

\* Model:

\* Serial:

\* Part Number:

SEARCH

**Can't Find Part or  
Manual? Request Help  
by Manufacturer,  
Model & Description**

**Parts Order Form**

Please fill in the following information to help us find the right part for your machine.

Manufacturer:	<input type="text"/>
Model:	<input type="text"/>
Description:	<input type="text"/>
Part Number:	<input type="text"/>
Quantity:	<input type="text"/>
Notes:	<input type="text"/>

Submit

Discount-Equipment.com is your online resource for quality parts & equipment.

Florida: **561-964-4949** Outside Florida TOLL FREE: **877-690-3101**

**Need parts?**

Click on this link: <http://www.discount-equipment.com/category/5443-parts/> and choose one of the options to help get the right parts and equipment you are looking for. Please have the machine model and serial number available in order to help us get you the correct parts. If you don't find the part on the website or on one of the online manuals, please fill out the request form and one of our experienced staff members will get back to you with a quote for the right part that your machine needs.

We sell worldwide for the brands: Genie, Terex, JLG, MultiQuip, Mikasa, Essick, Whiteman, Mayco, Toro Stone, Diamond Products, Generac Magnum, Airman, Haulotte, Barreto, Power Blanket, Nifty Lift, Atlas Copco, Chicago Pneumatic, Allmand, Miller Curber, Skyjack, Lull, Skytrak, Tsurumi, Husquvarna Target, Stow, Wacker, Sakai, Mi-T-M, Sullair, Basic, Dynapac, MBW, Weber, Bartell, Bennar Newman, Haulotte, Ditch Runner, Menegotti, Morrison, Contec, Buddy, Crown, Edco, Wyco, Bomag, Laymor, EZ Trench, Bil-Jax, F.S. Curtis, Gehl Pavers, Heli, Honda, ICS/PowerGrit, IHI, Partner, Imer, Clipper, MMD, Koshin, Rice, CH&E, General Equipment, Amida, Coleman, NAC, Gradall, Square Shooter, Kent, Stanley, Tamco, Toku, Hatz, Kohler, Robin, Wisconsin, Northrock, Oztec, Toker TK, Rol-Air, APT, Wylie, Ingersoll Rand / Doosan, Innovatech, Con X, Ammann, Mecalac, Makinex, Smith Surface Prep, Small Line, Wanco, Yanmar

# TABLE OF CONTENTS

## SP1G Concrete Saw

Table Of Contents.....	2
Explanation Of Code In Remarks Column.....	4
Suggested Spare Parts .....	5

## Component Drawings

Nameplate And Decals Assembly .....	6-7
Lowering Assembly .....	8-9
Rear Main Assembly .....	10-11
Engine Mount Assembly.....	12-13
Blade Guard Assembly.....	14-15
Pointer And Handle Bar Assembly .....	16-17
Bearing/Blade Shaft Assembly.....	18-19

## Honda GX200UT2QXC9 Component Drawings

Recoil Starter Assembly .....	20-21
Fan Cover Assembly.....	22-23
Carburetor Assembly.....	24-25
Air Cleaner Assembly .....	26-27
Muffler Assembly .....	28-29
Fuel Tank Assembly.....	30-31
Flywheel Assembly.....	32-33
Cylinder Head Assembly .....	34-35
Ignition Coil Assembly .....	36-37
Control Assembly .....	38-39
Cylinder Barrel Assembly .....	40-41
Crankcase Cover Assembly.....	42-43
Crankshaft Assembly.....	44-45
Piston Assembly.....	46-47
Camshaft Assembly.....	48-49
Label Assembly .....	50-51

### NOTICE

Specifications and part numbers are subject to change without notice.

# EXPLANATION OF CODE IN REMARKS COLUMN

The following section explains the different symbols and remarks used in the Parts section of this manual. Use the help numbers found on the back page of the manual if there are any questions.

**NOTICE**

The contents and part numbers listed in the parts section are subject to change **without notice**. Multiquip does not guarantee the availability of the parts listed.

## SAMPLE PARTS LIST

NO.	PART NO.	PART NAME	QTY.	REMARKS
1	12345	BOLT .....	1	INCLUDES ITEMS W/%
2%		WASHER, 1/4 IN. ....		NOT SOLD SEPARATELY
2%	12347	WASHER, 3/8 IN. ...	1	MQ-45T ONLY
3	12348	HOSE .....	A/R	MAKE LOCALLY
4	12349	BEARING .....	1	S/N 2345B AND ABOVE

## NO. Column

**Unique Symbols** — All items with same unique symbol (@, #, +, %, or >) in the number column belong to the same assembly or kit, which is indicated by a note in the “Remarks” column.

**Duplicate Item Numbers** — Duplicate numbers indicate multiple part numbers, which are in effect for the same general item, such as different size saw blade guards in use or a part that has been updated on newer versions of the same machine.

**NOTICE**

When ordering a part that has more than one item number listed, check the remarks column for help in determining the proper part to order.

## PART NO. Column

**Numbers Used** — Part numbers can be indicated by a number, a blank entry, or TBD.

TBD (To Be Determined) is generally used to show a part that has not been assigned a formal part number at the time of publication.

A blank entry generally indicates that the item is not sold separately or is not sold by Multiquip. Other entries will be clarified in the “Remarks” Column.

## QTY. Column

**Numbers Used** — Item quantity can be indicated by a number, a blank entry, or A/R.

A/R (As Required) is generally used for hoses or other parts that are sold in bulk and cut to length.

A blank entry generally indicates that the item is not sold separately. Other entries will be clarified in the “Remarks” Column.

## REMARKS Column

Some of the most common notes found in the “Remarks” Column are listed below. Other additional notes needed to describe the item can also be shown.

**Assembly/Kit** — All items on the parts list with the same unique symbol will be included when this item is purchased.

Indicated by:

“INCLUDES ITEMS W/(unique symbol)”

**Serial Number Break** — Used to list an effective serial number range where a particular part is used.

Indicated by:

“S/N XXXXX AND BELOW”

“S/N XXXX AND ABOVE”

“S/N XXXX TO S/N XXX”

**Specific Model Number Use** — Indicates that the part is used only with the specific model number or model number variant listed. It can also be used to show a part is NOT used on a specific model or model number variant.

Indicated by:

“XXXXX ONLY”

“NOT USED ON XXXX”

**“Make/Obtain Locally”** — Indicates that the part can be purchased at any hardware shop or made out of available items. Examples include battery cables, shims, and certain washers and nuts.

**“Not Sold Separately”** — Indicates that an item cannot be purchased as a separate item and is either part of an assembly/kit that can be purchased, or is not available for sale through Multiquip.

## SUGGESTED SPARE PARTS

### SP1G CONCRETE SAW

#### 1 to 3 Units

Qty.	P/N	Description
2	38465	BELT, 3VX400
2	35127	SWITCH, KILL

#### NOTICE

Part numbers on this Suggested Spare Parts list may supersede/replace the part numbers shown in the following parts lists.

### HONDA GX200UT2QXC9 GASOLINE ENGINE

#### 1 to 3 units

Qty.	P/N	Description
1	17620Z4H030	CAP FUEL TANK
1	34150ZH7013	SWITCH ASSY., OIL ALERT
2	28462ZH8003	ROPE, RECOIL
3	7210ZE2515	ELEMENT AIR CLEANER
1	17218ZE2505	FILTER, OUTER
3	9807956846	SPARK PLUG, BPR6ES

# NAMEPLATE AND DECALS ASSY.

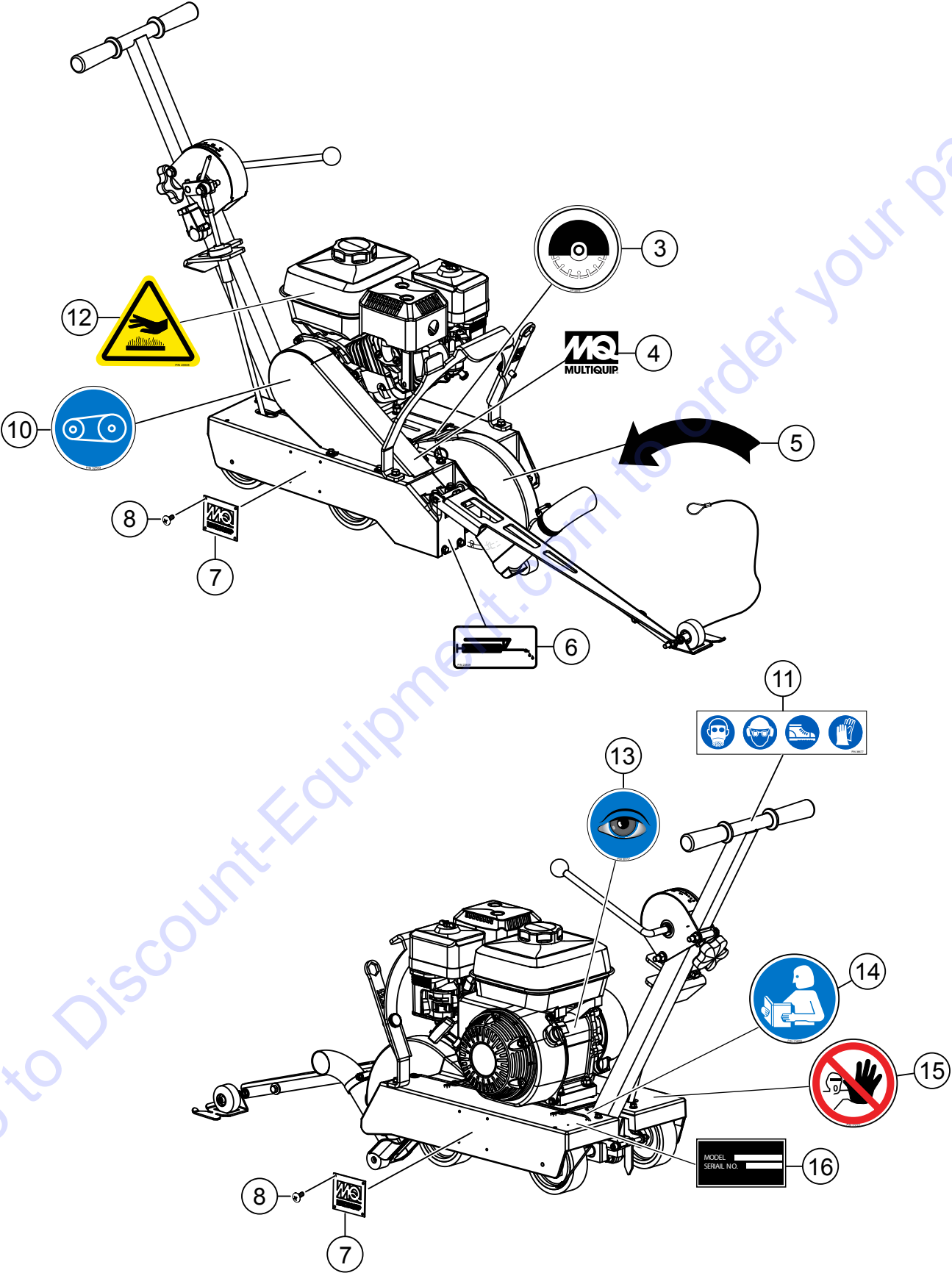

## NAMEPLATE AND DECALS ASSY.

<u>NO.</u>	<u>PART NO.</u>	<u>PART NAME</u>	<u>QTY.</u>	<u>REMARKS</u>
3	38678	DECAL; GUARDS IN PLACE, 2.00" DIA.	1	
4	25482	DECAL, MQ LOGO (SMALL)	1	
5	25491	DECAL; BLADE ROTATION CW	1	
6	23809	DECAL; LUBRICATION POINT, 2.0" X 1.0"	1	
7	38667	PLATE, MQ LOGO	2	
8	34306	SCREW, PHP, #10-32 X 5/8"	4	
9	25482	DECAL, MQ LOGO (LARGE), 3.0" X 3-3/4"	1	
10	32553	DECAL; ISO: BELT DRIVE, 1.00" DIA.	1	
11	38677	DECAL; ISO: PROTECTION EQUIPMENT REQUIRED	1	
12	23808	DECAL; ISO: HOT SURFACE HAZARD 2.4" X 2.00"	1	
13	30117	DECAL; ISO:EYE, INSPECTION, 1.00" DIA.	1	
14	23699	DECAL; ISO: READ MANUAL, 2.00" DIA.	1	
15	23701	DECAL; ISO: ASK FOR TRAINING, 2.00" DIA.	1	
16		SERIAL NUMBER PLATE .....	1	CONTACT DISCOUNT-EQUIPMENT.

Go to Discount-Equipment.com to order your parts

# LOWERING ASSY.

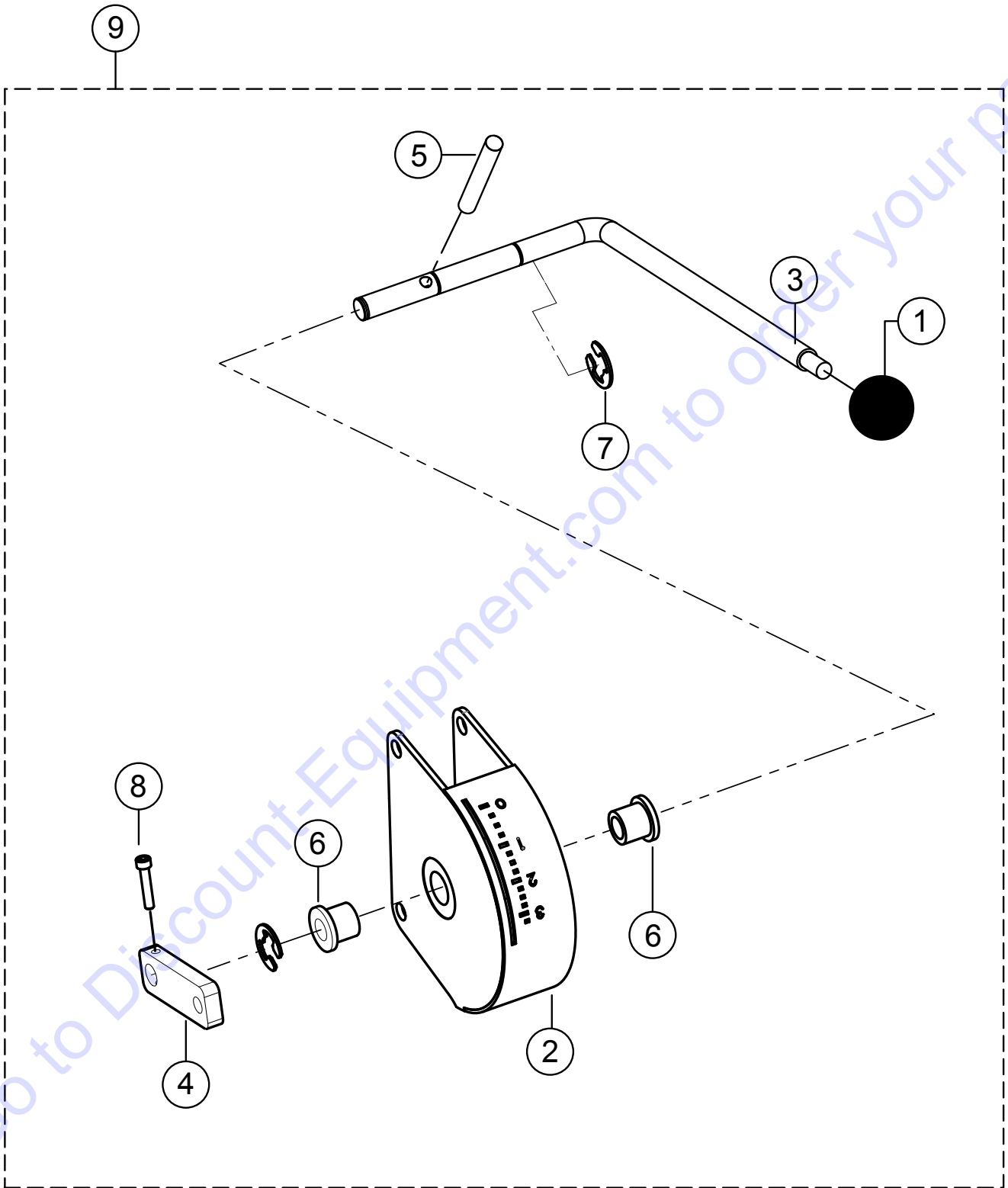



## LOWERING ASSY.

<u>NO.</u>	<u>PART NO.</u>	<u>PART NAME</u>	<u>QTY.</u>	<u>REMARKS</u>
1%	4403	SHIFT KNOB, 1-3/8" DIA 3/8-16	1	
2%	38438	DEPTH INDICATOR	1	
3%	38500	SHAFT, FLAT END LOWERING LEVER	1	
4%	38512	LINK, OVER CENTER SYSTEM DRIVING	1	
5%	38607	ROD, LOWERING INDICATOR	1	
6%	38621	BUSHING, .5ID X .75D X .75L	2	
7%	38627	RING, EXTERNAL RETAINING	3	
8%	46129	SLEEVE, LOWERING PIVOT	1	
9	38502	LOWERING ASSY., OVER CENTER.....	1.....	INCLUDES ITEMS W/%

Go to Discount-Equipment.com to order your parts

# REAR MAIN ASSY.

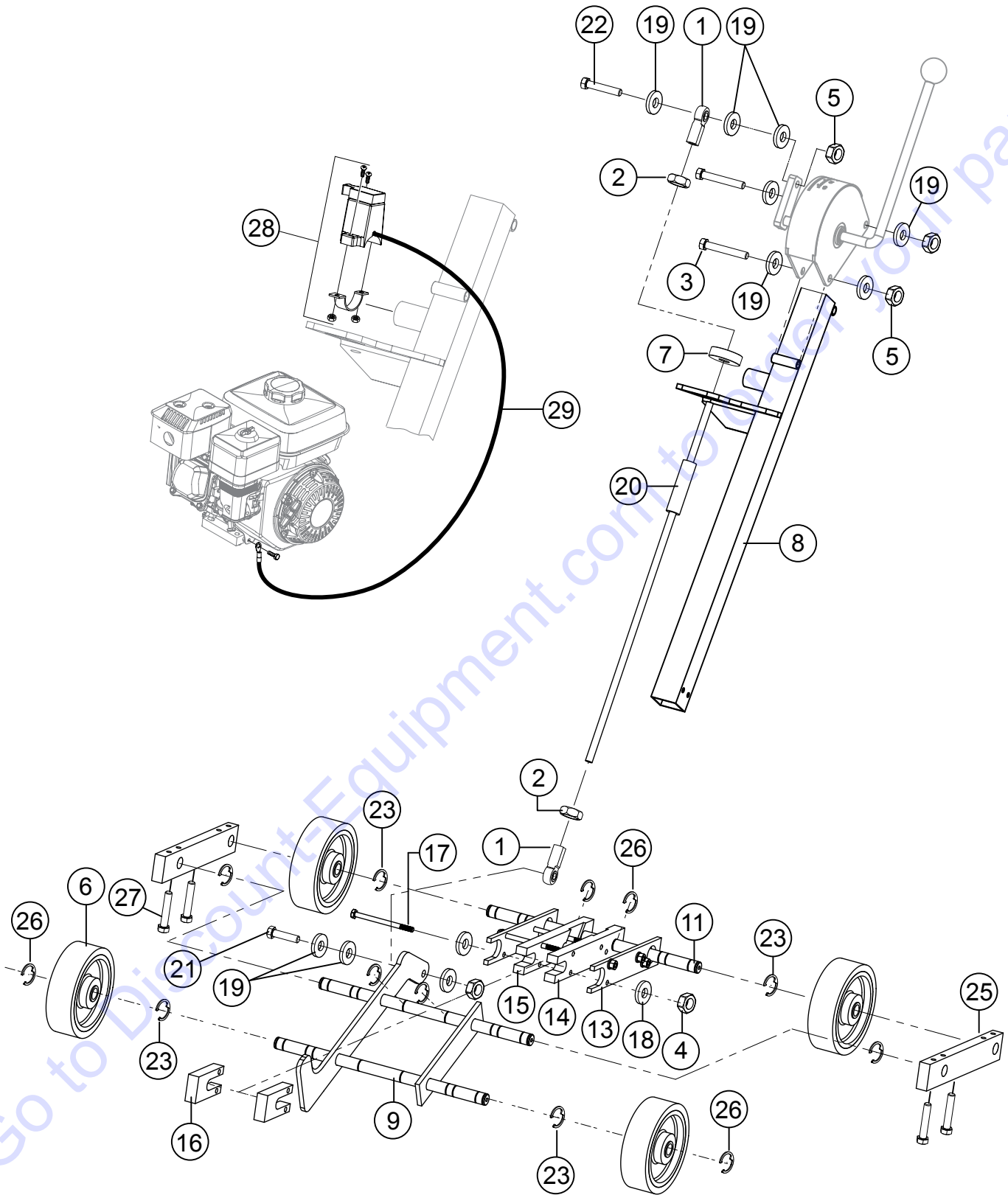

## REAR MAIN ASSY.

<u>NO.</u>	<u>PART NO.</u>	<u>PART NAME</u>	<u>QTY.</u>	<u>REMARKS</u>
1	2064	ROD END, 3/8-24 FEMAL RH	2	
2	2199	NUT, HEX JAM 3/8-24	2	
3	8156	SCREW, HHC 3/8-16 X 2-1/2	2	
4	10024	NUT, NYLOC 1/4-20	4	
5	10133	NUT, NYLOC 3/8-16	4	
6	25407	WHEEL, 5 X .625 X 1.5 BALL BEARING	4	
7	25448	DEPTH ADJUSTMENT DISC	1	
8	38385	HANDLE, LOWER	1	
9	38421	FRONT AXLE	1	
11	38516	SHAFT, MAIN AXLE	1	
13	38600	PLATE, VIBRATION ISOLATION STIFFENER	2	
14	38608	BASE, LEFT VIBRATION MOUNT	1	
15	38609	BASE, RIGHT VIBRATION MOUNT	1	
16	38610	CLIP, FRONT AXLE VIBRATION MOUNT	2	
17	38636	SCREW, HHC 1/4-20 X 3.5 GRD 5	4	
18	933240	WASHER, FLAT SAE 1/4 GRD 9	8	
19	933242	WASHER, FLAT SAE 3/8 GRD 9	10	
20	38639	DEPTH STOP LINKAGE	1	
21	1284	SCREW, HHC 3/8-16 X 1-1/2	1	
22	1665	SCREW, HHC 3/8-16 X 2	1	
23	38694	MOUNT ASSY., MAIN AXLE	1	
24	38527	INSERT, 1/4-20 KNURLED BRASS SLOTTED	3	
25	38525	MOUNT, AXLE MAIN	2	
26	38518	RETAINING RING, 5/8" SHAFT SIDE MOUNT	8	
27	0243	SCREW, SHC 5/16-18 X 1-3/4"	8	
28	35127	SWITCH, KILL	1	
29	38692	HARNESS, KILL SWITCH	1	

# ENGINE MOUNT ASSY.

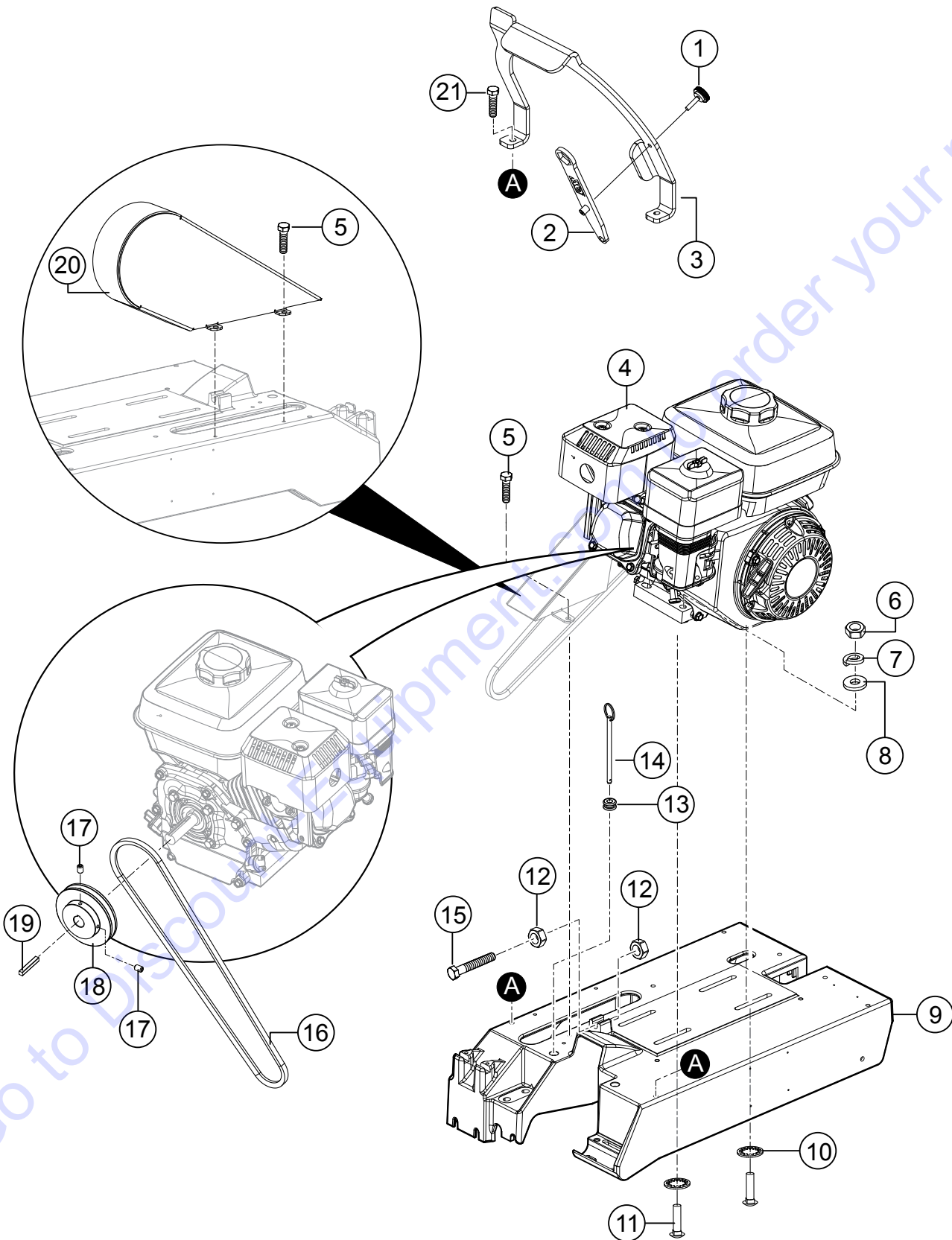

## ENGINE MOUNT ASSY.

<u>NO.</u>	<u>PART NO.</u>	<u>PART NAME</u>	<u>QTY.</u>	<u>REMARKS</u>
1	21468	KNOB, PLASTIC 1/4-20 X 1 STUD	1	
2	38690	WRENCH ASM, SP1G COMBO	1	
3	38682	HANDLE, SP1G FRONT LIFT	1	
4	35542	ENGINE, HONDA GX200UT2QXC9 (5.5 HP)	1	
5	34364	SCREW, HHFS 1/4-20 X 1/2, GR5	3	
6	5283	NUT, NYLOC 5/16-18"	4	
7	0161 C	WASHER, LOCK 5/16" MED	4	
8	0300 B	WASHER, FLAT SAE 5/16	4	
9	38651	FRAME	1	
10	21986	WASHER,FAST LEAD-STAINLESS	4	
11	25410	BOLT, CARRIAGE 5/16-18 X 1.75	4	
12	10133	NUT, NYLOC 3/8-16"	2	
13	38664	GROMMET, 1/2ID X 11/16 THICK 1/4" PANEL	1	
14	38660	PIN, QUICK RELEASE 1/4 DIA X 3"	1	
15	38670	SCREW, HHC 3/8-16 X 4 FULL THREAD	1	
16	38465	BELT, 3VX400	1	
17	925381	SCREW, SET 1/4-20 X 3/8"	2	
18	35445	PULLEY, ENGINE DRIVE, 1F3V412 X 3/4" 2SS	2	
19	0627	KEY, 3/16 X 1-1/4"	1	
20	38414	BELT GUARD	1	
21	36720	SCREW, HHFS 5/16-18 x 3/4GR5	2	

# BLADE GUARD ASSY.

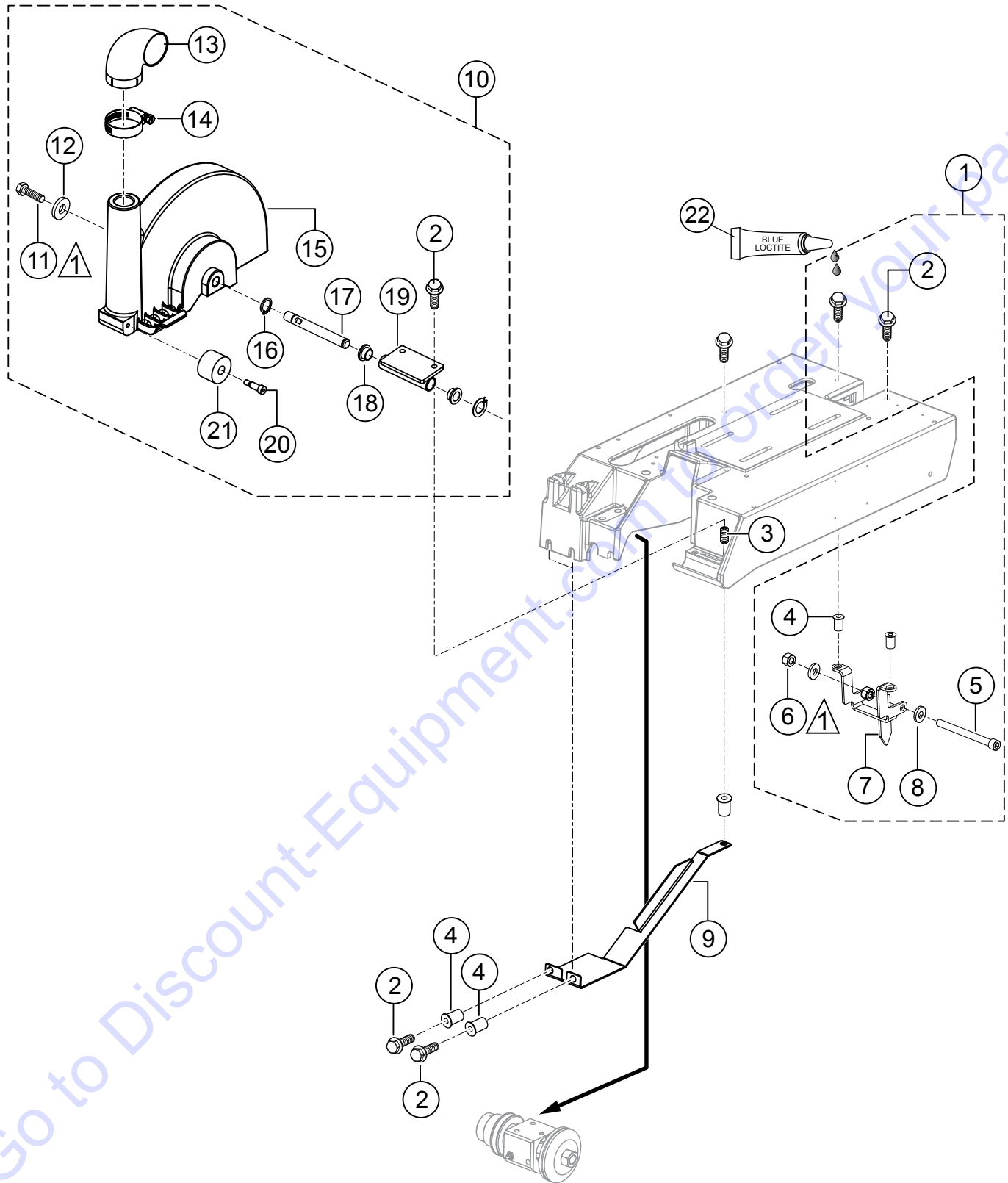

## NOTES:

1 APPLY BLUE LOCTITE 246 TO ALL SCREWS

## BLADE GUARD ASSY.

<u>NO.</u>	<u>PART NO.</u>	<u>PART NAME</u>	<u>QTY.</u>	<u>REMARKS</u>
1	38686	REAR POINTER ASSY .....	1.....	INCLUDES ITEMS W/@
2@#	49048	SCREW, HHFS 1/4-20 X 3/4, GR5	6	
3	38687	INSERT, 1/4-20 X .750 HELICOIL	1	
4@	19266	NUT, BLIND 1/4-20 X .027-.165	4	
5@	35476	SCREW, SHC 5/16-18 X 3.5 FULL THREAD	1	
6@	5283	NUT, NYLOC 5/16-18	3	
7@	38683	MOUNT, SP1G REAR POINTER	1	
8@	0300 B	WASHER, FLAT SAE 5/16	2	
9	38666	GUARD, SP1G LOWER BELT	1	
10	38659	BLADE GUARD ASSY .....	1.....	INCLUDES ITEMS W/#
11#	0655	SCREW, HHC 5/16-18 X 3/4	1	
12#	38654	WASHER, 5/16 X 1" OD BELLEVILLE	1	
13#	38689	ELBOW, SP1G DUST PORT	1	
14#	962015	CLAMP, HOSE WORM #28	1	
15#	38652	BLADE GUARD, SP1G V-PROCESS	1	
16#	38671	RING, BOWED EXTERNAL .500	1	
17#	38653	PIVOT, BLADE GUARD MAIN	1	
18#	30173	BUSHING, FLG., BRONZE, ID.51xOD.625	2	
19#	38658	PIVOT W/A, BLADE GUARD	1	
20#	38655	SCREW, SHSLDR .313 DIA.x.625L 1/4-20 SS	1	
21#	38434	WHEEL, 1.5 OD X .50 ID X 1.0 WIDTH	1	
22	60097	LOCTITE, 242	1	

# POINTER AND HANDLE BAR ASSY.

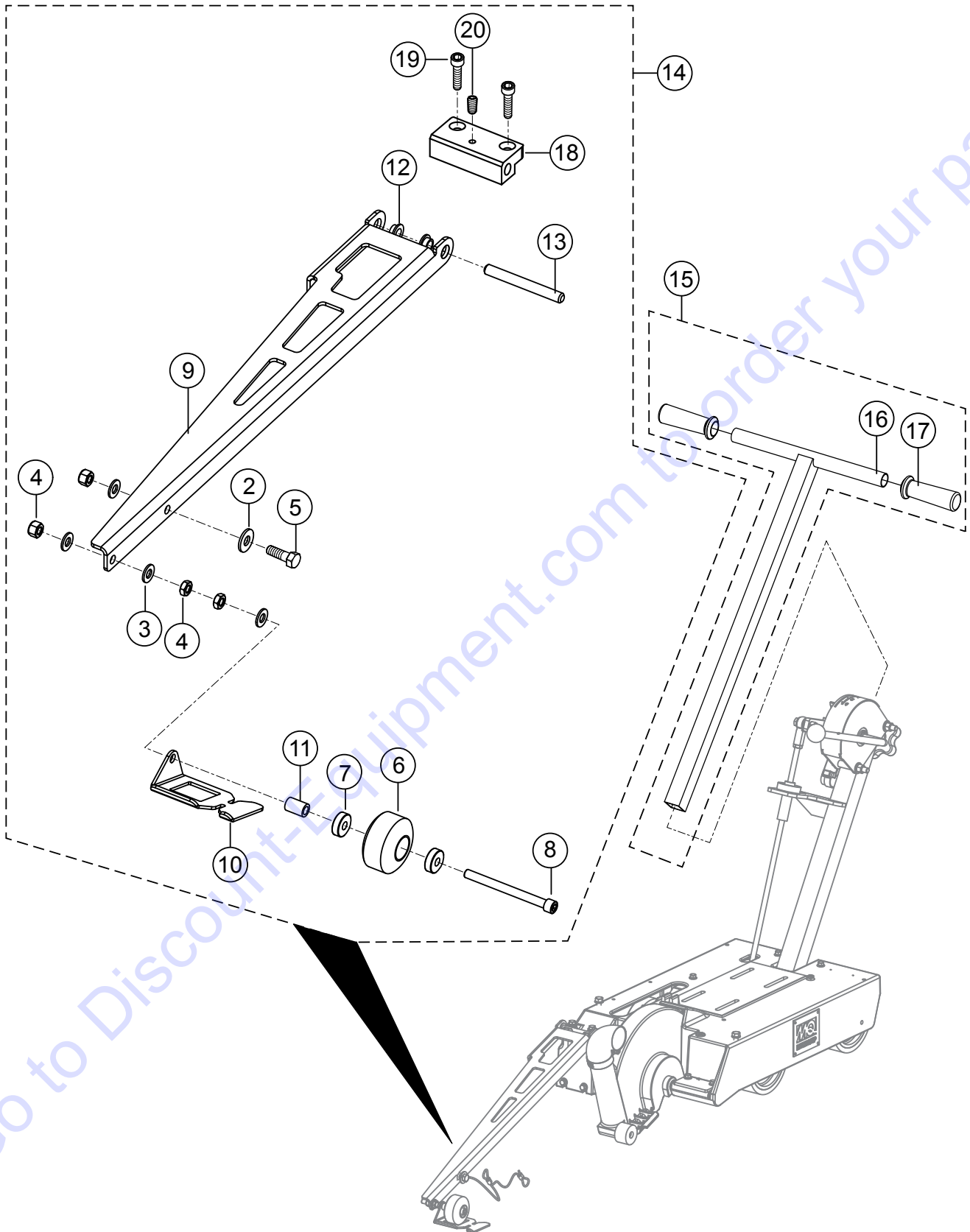



## POINTER AND HANDLE BAR ASSY.

<u>NO.</u>	<u>PART NO.</u>	<u>PART NAME</u>	<u>QTY.</u>	<u>REMARKS</u>
2@	202	SCREW, HHC 5/16-18 X 1 ZINC	1	
3@	0300 B	WASHER, FLAT SAE 5/16	4	
4@	5283	NUT, NYLOC 5/16-18	4	
5@	19470	WASHER, FLAT 5/16 USS	1	
6@	21189	WHEEL, 2.13 OD X 1.25 W	1	
7@	21369	BEARING, SEALED 5/16 ID X 7/8 OD	2	
8@	35476	SCREW, SHC 5/16-18 X 3.5 FULL THREAD	1	
9@	38398	PLATE, POINTER	1	
10@	38401	PLATE, DUAL SLOT RAISED EDGE POINTER	1	
11@	38463	BUSHING, 5/16ID X .50 OD X .75 L	1	
12@	38620	BUSHING, .375ID X .5OD X .25L SAE 863	2	
13@	38665	PIN, POINTER PIVOT	1	
14	38402	POINTER ASSY .....	1	INCLUDES ITEMS W/@
15	25419	HANDLEBAR ASSY .....	1	INCLUDES ITEMS W/#
16#	25374	HANDLE, UPPER	1	
17#	15081	GRIP, 1" ID X 4.5"L BLACK	2	
18	38695	BASE, POINTER MOUNT	1	
19	3164	SCREW, FHSC 1/4-20 X 1	2	
20	0130 A	SCREW, SHSCP 5/16-24 X 1/4	1	

# BEARING/BLADE SHAFT ASSY.

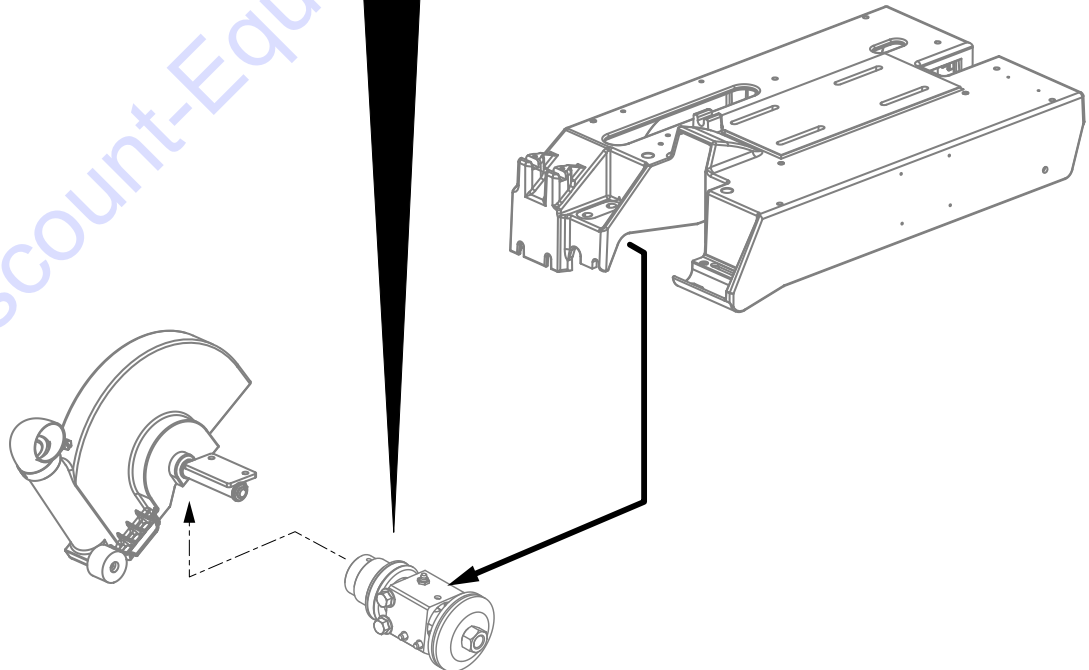
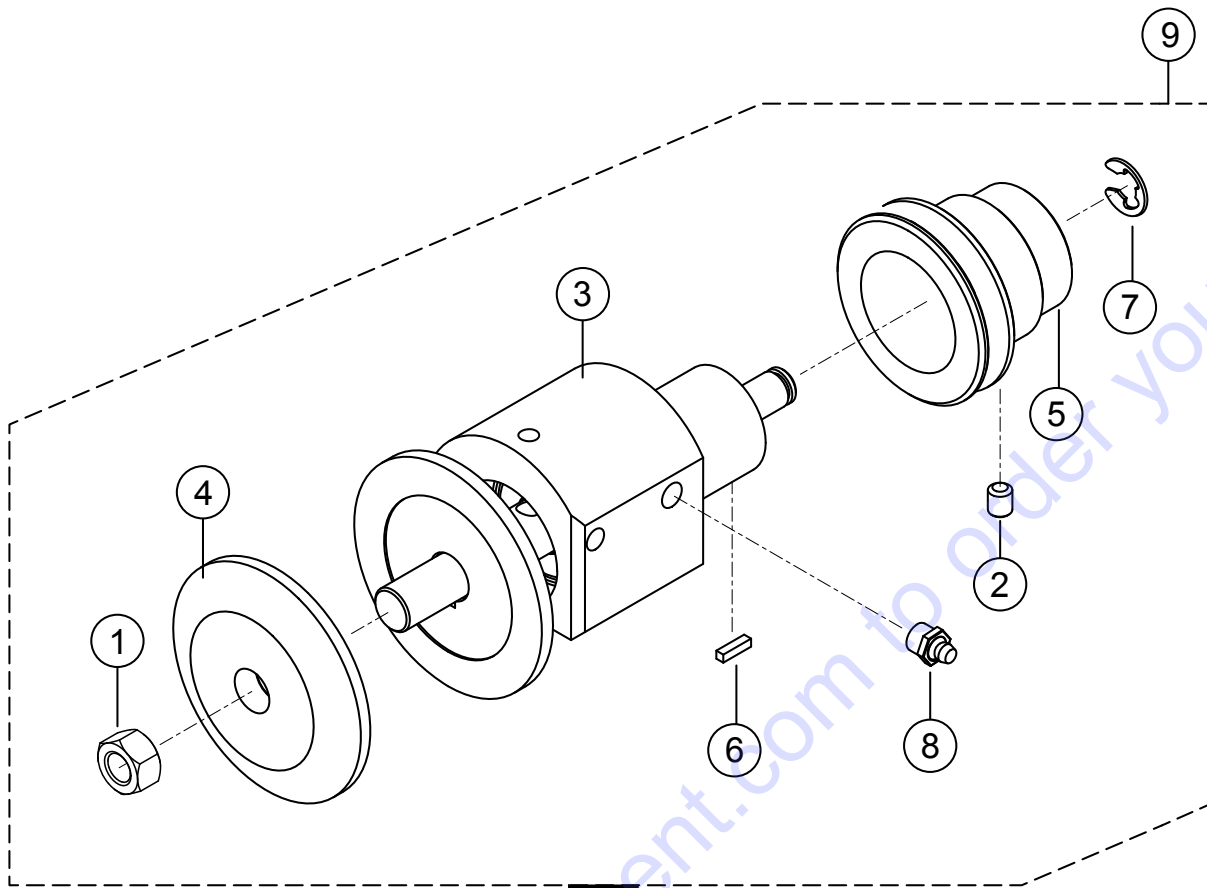

## BEARING/BLADE SHAFT ASSY.

<u>NO.</u>	<u>PART NO.</u>	<u>PART NAME</u>	<u>QTY.</u>	<u>REMARKS</u>
1#	19710	NUT, HEX FIN 5/8-11 L.H. THD	1	
2#	25490	SCREW, SHS 5/16-18 X 3/8	1	
3#	38409	BLADE SHAFT/FLANGE ASSY.	1	
4#	38458	FLANGE, BLADE OUTSIDE	1	
5#	38611	SHEAVE, 2.66 X 3V DEEP BORE	1	
6#	38622	KEY, 1/8 SQ X 1/2"	1	
7#	38623	SNAP RING BOWED	1	
8#	960102	FITTING, GREASE ZERK STR 1/8 MP	1	
9	38410	BEARING/SHAFT ASSY.....	1.....	INCLUDES ITEMS W/#

Go to Discount-Equipment.com to order your parts

# HONDA GX200UT2QXC9 — RECOIL STARTER ASSY.

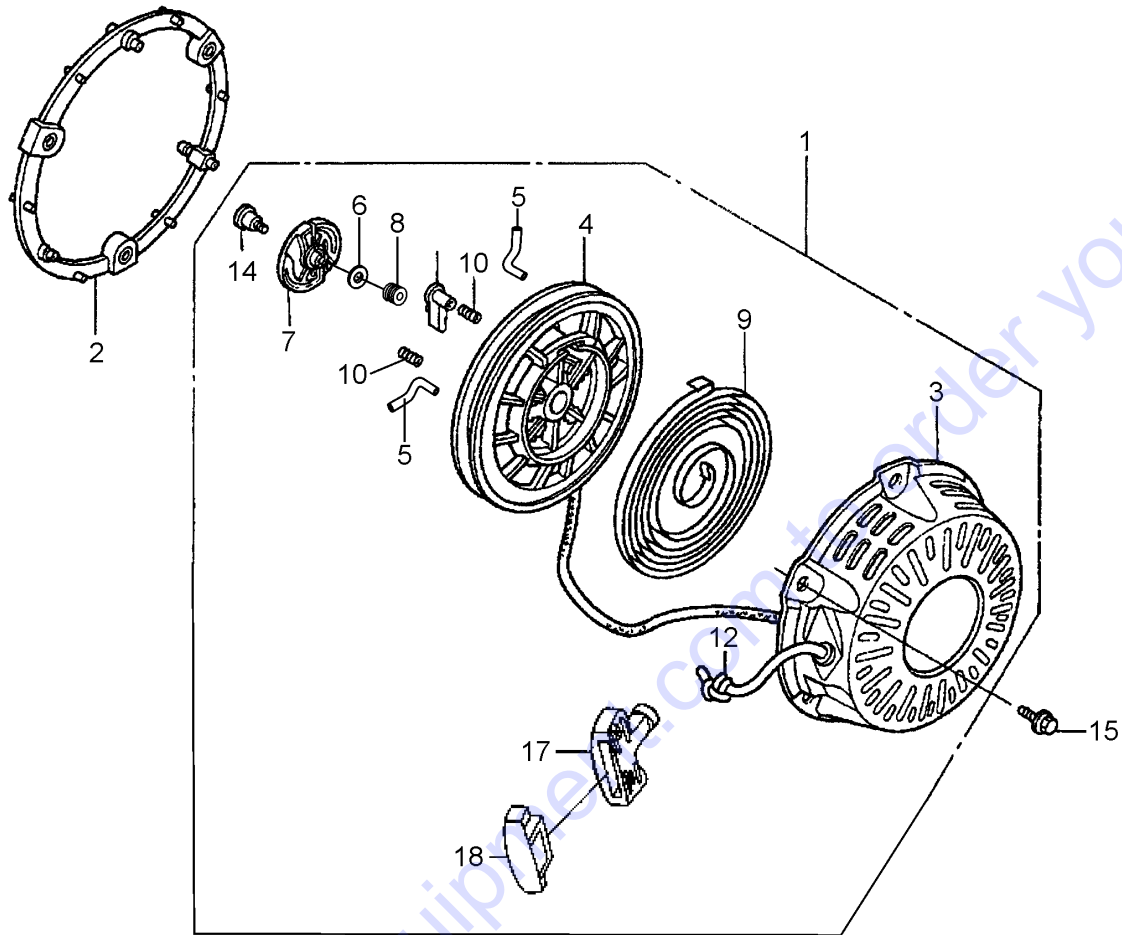

## HONDA GX200UT2QXC9 — RECOIL STARTER ASSY.

<u>NO.</u>	<u>PART NO.</u>	<u>PART NAME</u>	<u>QTY.</u>	<u>REMARKS</u>
1	28400Z4M305ZD	STARTER ASSY., RECOIL *NH1* .....	1.....	INCLUDES ITEMS W/#
2	28405ZL0000ZA	SPACER, RECOIL STARTER MOUNTING	1	
3#	28410Z4M003ZD	CASE COMP., RECOIL STARTER, NH1	1	
4#	28421Z0T003	PULLEY, RECOIL STARTER	1	
5#	28422ZH8801	RATCHET, STARTER	2	
6#	28431ZH8801	PLATE, FRICTION	1	
7#	28433ZH8801	GUIDE, RATCHET	1	
8#	28441ZH8801	SPRING, FRICTION	1	
9#	28442ZH8003	SPRING, RECOIL STARTER	1	
10#	28443ZH8801	SPRING, RETURN	2	
12#	28462ZH8003	ROPE, RECOIL STARTER	1	
14#	90003ZH8801	SCREW, SETTING	1	
15	957010601800	BOLT, FLANGE, 6X18	3	
17#	28461Z4M305	KNOB, RECOIL STARTER	1	
18#	28463Z4M003	KNOB, REINFORCEMENT	1	

Go to Discount-Equipment.com to order your parts

# HONDA GX200UT2QXC9 — FAN COVER ASSY.

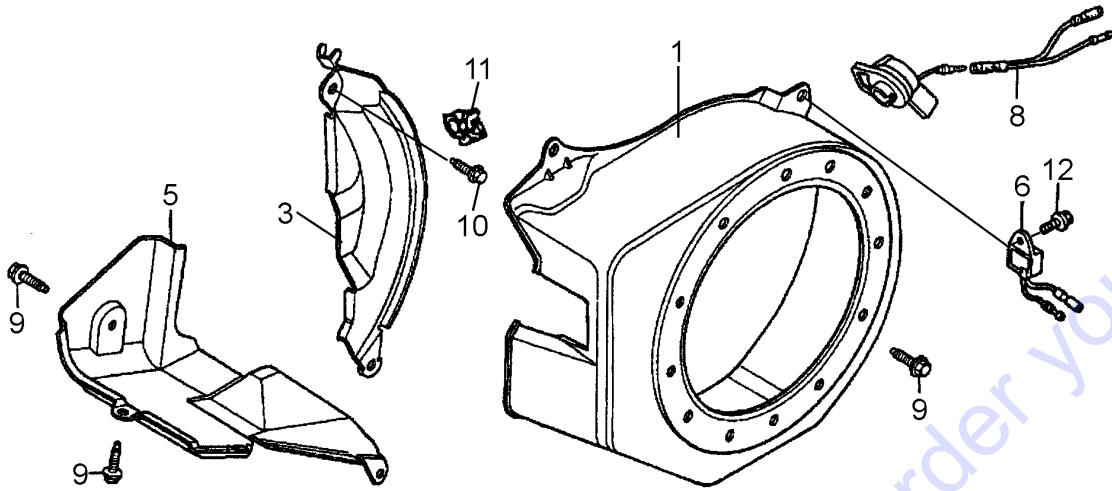

Go to Discount-Equipment.com to order your parts

## HONDA GX200UT2QXC9 — FAN COVER ASSY.

<u>NO.</u>	<u>PART NO.</u>	<u>PART NAME</u>	<u>QTY.</u>	<u>REMARKS</u>
1	19610Z4M000ZB	COVER COMP., FAN, NH1, BLACK	1	
3	19611Z4M810	PLATE COMP., SIDE (OIL ALERT)	1	
5	19630ZH8000	SHROUD COMP.	1	
6	34150ZH7013	ALERT UNIT, OIL	1	
8	35120Z0T851	SWITCH ASSY., ENGINE STOP	1	
9	90013883000	BOLT, FLANGE, 6X12	6	
10	90022888010	BOLT, FLANGE, 6X20	1	
11	90601ZH7013	CLIP, TUBE	1	
12	957010600800	BOLT, FLANGE, 6X8	1	

Go to Discount-Equipment.com to order your parts

# HONDA GX200UT2QXC9 — CARBURETOR ASSY.

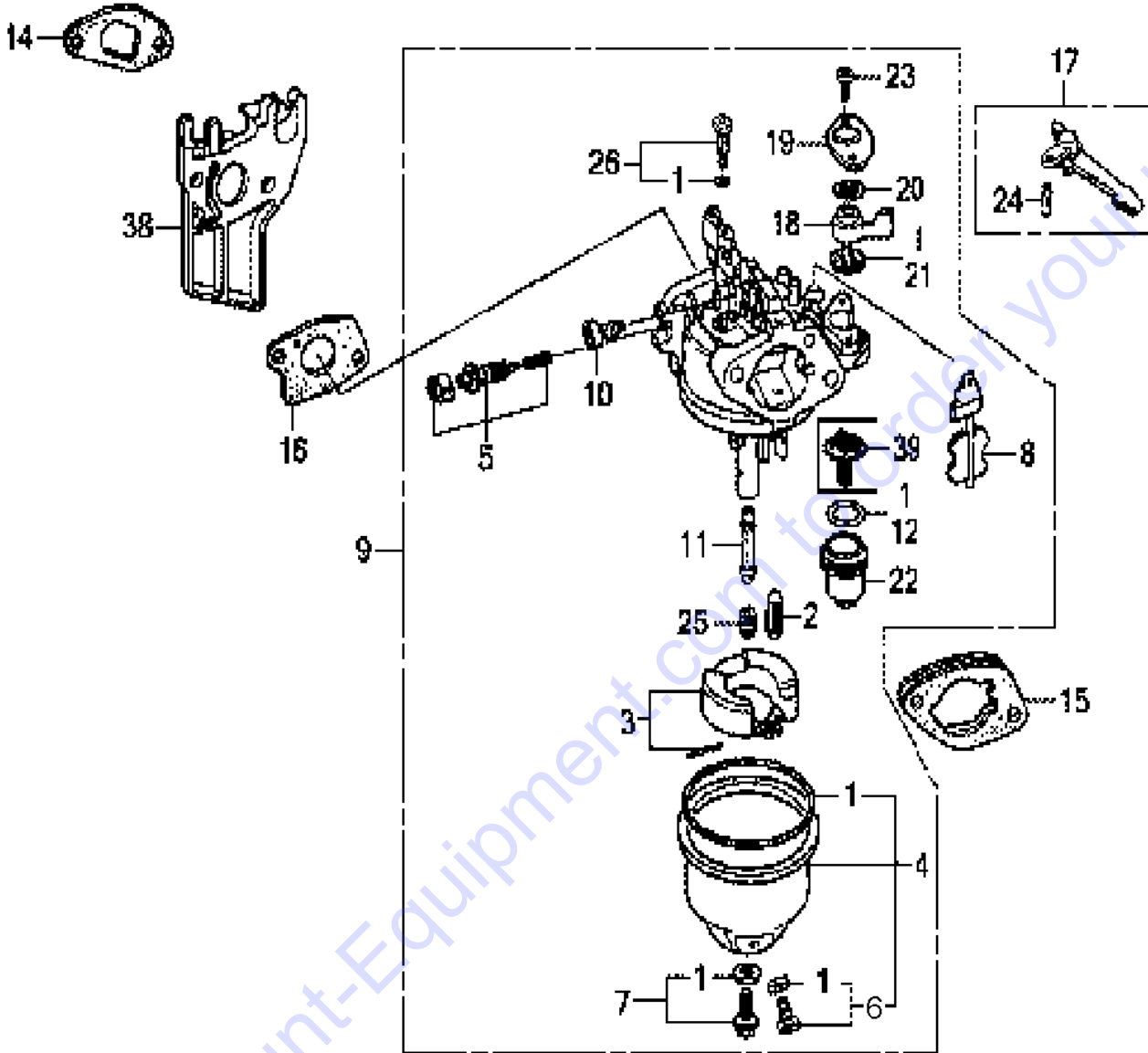

## NOTICE

Gasket Set, item 1 included with items 4, 7, 8, 12, 21, and 26.



## HONDA GX200UT2QXC9 — CARBURETOR ASSY.

<u>NO.</u>	<u>PART NO.</u>	<u>PART NAME</u>	<u>QTY.</u>	<u>REMARKS</u>
1#	16010ZE1812	GASKET SET	1	
2#	16011ZE0005	VALVE SET, FLOAT	1	
3#	16013Z0SB01	FLOAT SET	1	
4#	16015Z4M911	CHAMBER SET, FLOAT .....	1	INCLUDES ITEM W/\$
5#	16016ZH7W01	SCREW SET, PILOT	1	
6#	16024Z5T901	SCREW SET, DRAIN	1	
7#	16028Z5T901	SCREW SET .....	1	INCLUDES ITEM W/\$
8#	16044ZE0005	CHOKE SET .....	1	INCLUDES ITEM W/\$
9	16100Z4VV31	CARBURETOR ASSY. (BE59R A) .....	1	INCLUDES ITEMS W/#
10#	16124ZE0005	SCREW, THROTTLE STOP	1	
11#	16166ZL0V20	NOZZLE, MAIN	1	
12#	16075GHBB00	PACKING, FUEL STRAINER CUP .....	1	REPLACES P/N 16955283000 INCLUDES ITEM W/\$
14	16212ZH8800	PACKING, INSULATOR	1	
15	16220ZE1020	SPACER COMP., CARBURETOR	1	
16	16221ZH8801	PACKING, CARBURETOR	1	
17	16610ZE1000	LEVER COMP., CHOKE (STD.) .....	1	INCLUDES ITEM W/%
18#	16953ZE1812	LEVER, COCK	1	
19#	16954ZE1812	PLATE, LEVER SETTING	1	
20#	16956ZE1811	SPRING, COCK LEVER	1	
21#	16957ZE1812	PACKING, FUEL COCK .....	1	INCLUDES ITEM W/\$
22#	16967ZE0811	CUP, FUEL STRAINER	1	
23#	93500030060H	SCREW, PAN, 3X6 .....	2	REPLACES P/N 93500030061H
24%	9430520122	PIN, SPRING, 2X12	1	
25#	99101ZH80700	JET, MAIN, #70	1	
25#	99101ZH80720	JET, MAIN, #72	1	
25#	99101ZH80750	JET, MAIN, #75	1	
26#	99204ZA00450	JET SET, PILOT, #45 .....	1	INCLUDES ITEM W/\$
38	16211Z4V000	INSULATOR, CARBURETOR	1	
39#	16959Z5T901	FILTER, CUP	1	

# HONDA GX200UT2QXC9 — AIR CLEANER ASSY.

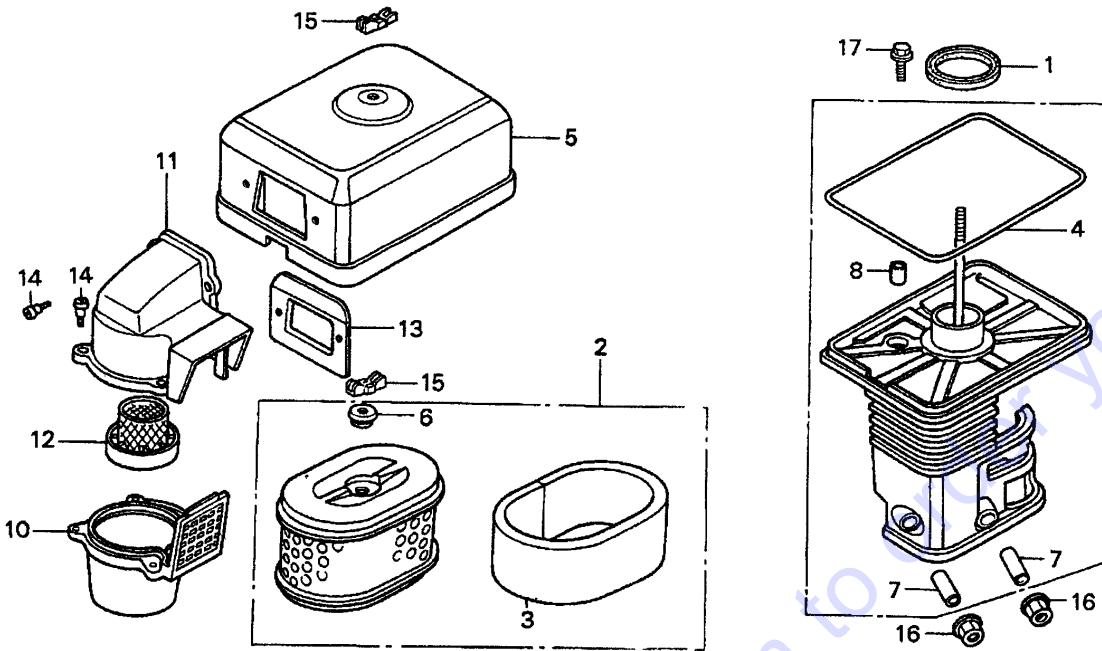

## HONDA GX200UT2QXC9 — AIR CLEANER ASSY.

<u>NO.</u>	<u>PART NO.</u>	<u>PART NAME</u>	<u>QTY.</u>	<u>REMARKS</u>
1	16271ZE1000	PACKING, ELBOW	1	
2	17210ZE2515	ELEMENT, AIR CLEANER (DUAL) .....	1	INCLUDES ITEMS W/# REPLACES P/N 17210ZE2822
3#	17218ZE2505	FILTER, OUTER .....	1	REPLACES P/N 17218ZE2821
4%	17219733010	PACKING, AIR CLEANER COVER	1	
5	17230ZE1841	COVER, AIR CLEANER (DUAL)	1	
6#	17232891000	GROMMET, AIR CLEANER	1	
7%	17238ZE7010	COLLAR, AIR CLEANER	2	
8%	17239733000	COLLAR B, AIR CLEANER	1	
9	17410ZE1840	ELBOW COMP., AIR CLEANER .....	1	INCLUDES ITEMS W/%
10	17470ZE1842	CASE, PRE AIR CLEANER	1	
11	17475ZE1841	CAP, PRE AIR CLEANER	1	
12	17476ZE1841	GUIDE, PRE AIR CLEANER	1	
13	17478ZE1841	PLATE, PRE AIR CLEANER	1	
14	90300GB0900	BOLT, MUD GUARD	5	
15	90325044000	WING NUT	2	
16	9405006000	NUT, FLANGE, 6MM	2	
17	957010602000	BOLT FLANGE, 6X20	1	

# HONDA GX200UT2QXC9 — MUFFLER ASSY.

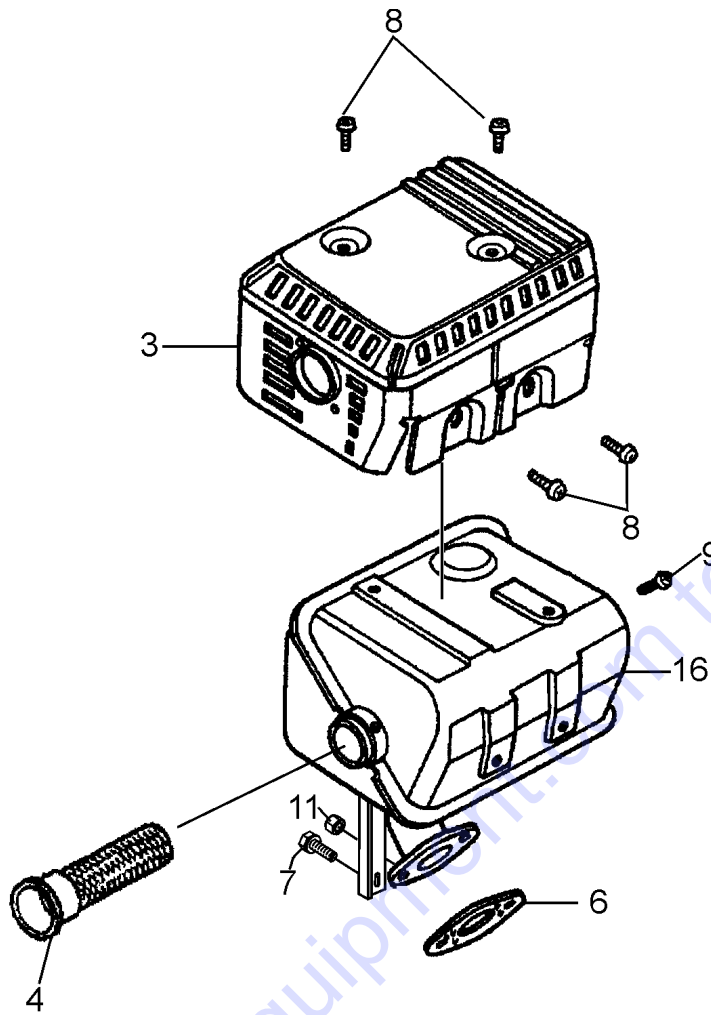

## HONDA GX200UT2QXC9 — MUFFLER ASSY.

<u>NO.</u>	<u>PART NO.</u>	<u>PART NAME</u>	<u>QTY.</u>	<u>REMARKS</u>
3	18320Z4V000	PROTECTOR COMP., MUFFLER	1	
4	18355ZL0000	ARRESTER, SPARK	1	
6	18381Z0T801	GASKET, MUFFLER	1	
7	90016ZE1000	BOLT, FLANGE, 6X13	1	
8	90050ZE1000	SCREW, TAPPING, 5X8	4	
9	90055ZE1000	SCREW, TAPPING, 4X6	1	
11	020108060	NUT, HEX, 8MM .....	2	REPLACES P/N 94001080000S
16	18310Z4V000	MUFFLER COMP.	1	

Go to Discount-Equipment.com to order your parts

# HONDA GX200UT2QXC9 — FUEL TANK ASSY.

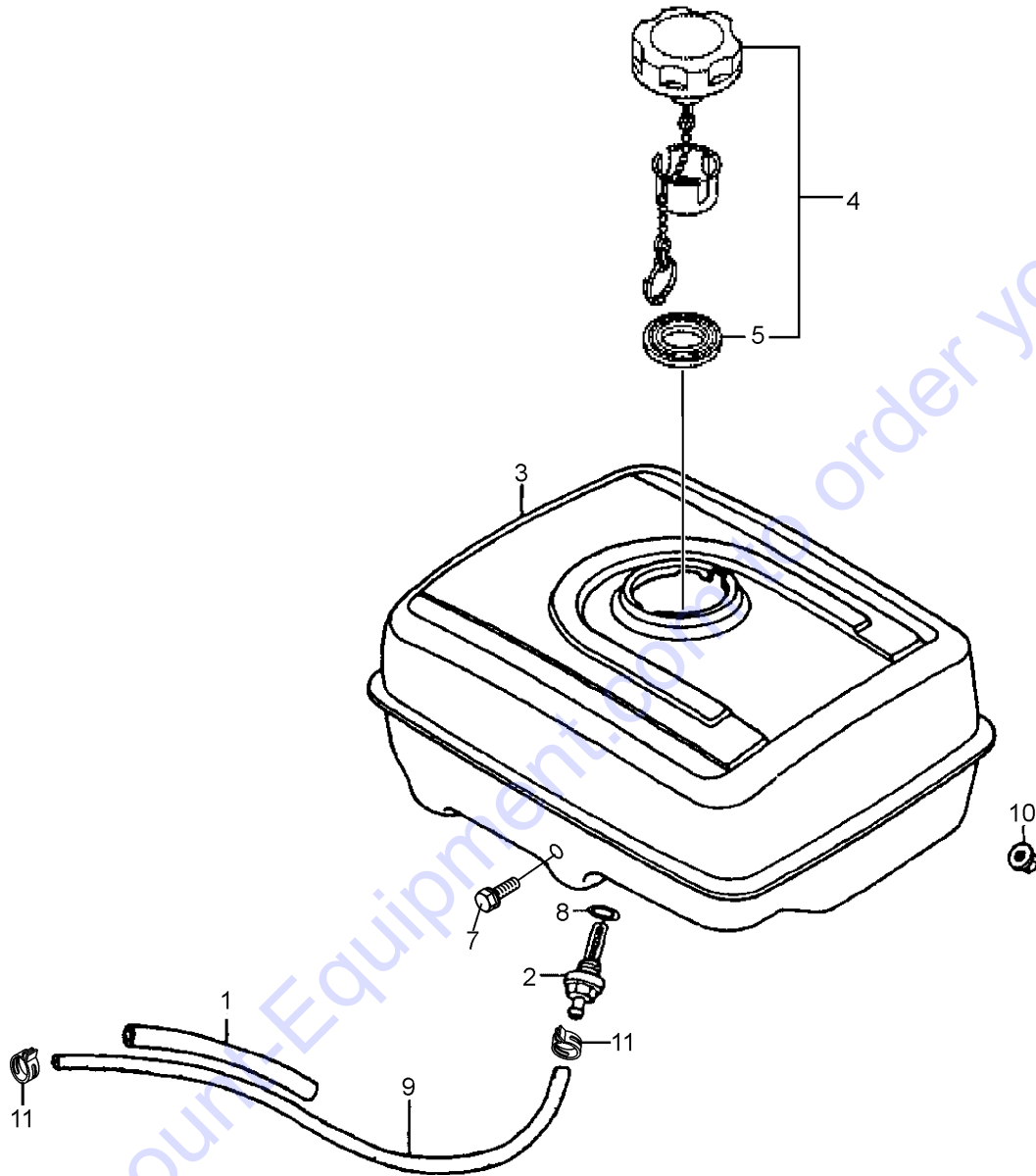

## HONDA GX200UT2QXC9 — FUEL TANK ASSY.

<u>NO.</u>	<u>PART NO.</u>	<u>PART NAME</u>	<u>QTY.</u>	<u>REMARKS</u>
1	16854ZH8000	RUBBER, SUPPORTER (107 MM)	1	
2	16955ZE1010	JOINT, FUEL TANK	1	
3	17510Z4M000ZB	TANK, COMP., FUEL *NH1*, BLACK	1	
4	17620Z4H030	CAP COMP., FUEL FILLER .....	1	INCLUDES ITEM W/\$
5\$	17631Z0T801	GASKET, FUEL FILLER CAP	1	
7	90004ZL0003	BOLT, FLANGE 6X34	1	
8	91353671003	O-RING 14 MM .....	1	REPLACES P/N 91353671004
9	91424Z4M003	TUBE, FUEL (4.5X145)	1	
10	9405006000	NUT, FLANGE 6MM	2	
11	950024080008	CLAMP, TUBE	2	

Go to Discount-Equipment.com to order your parts

# HONDA GX200UT2QXC9 — FLYWHEEL ASSY.

---

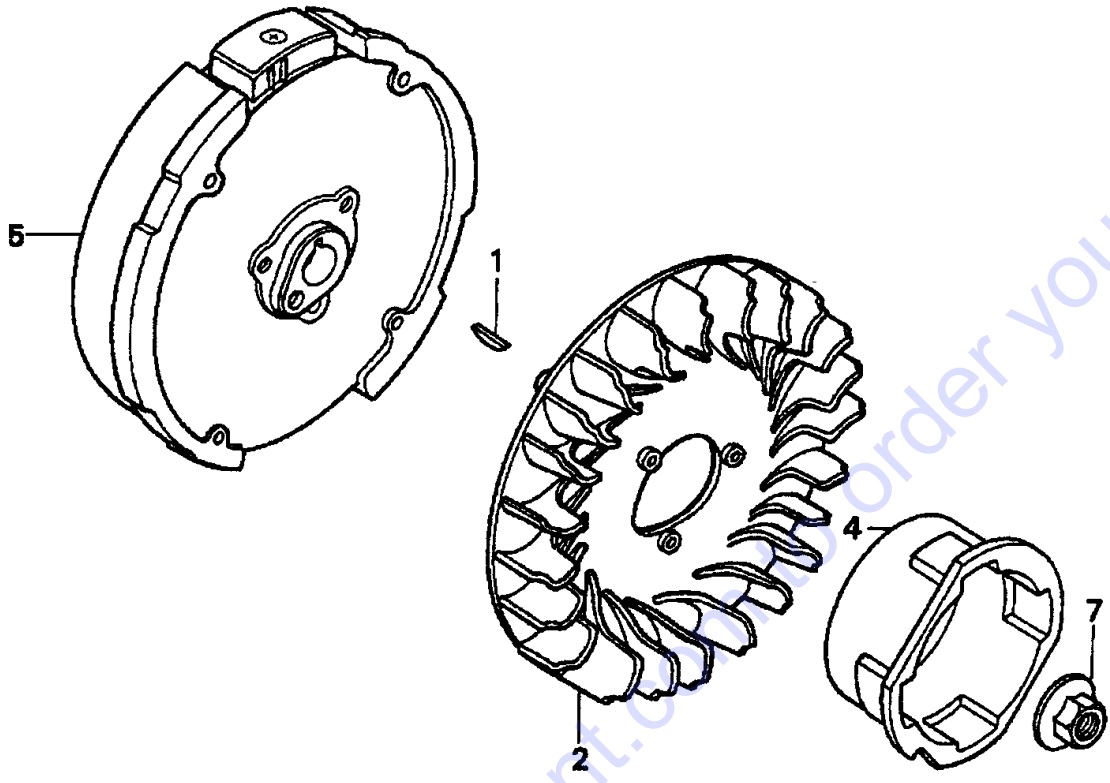

Go to Discount-Equipment.com to order your parts



## HONDA GX200UT2QXC9 — FLYWHEEL ASSY.

---

<u>NO.</u>	<u>PART NO.</u>	<u>PART NAME</u>	<u>QTY.</u>	<u>REMARKS</u>
1	13331357000	KEY, SPECIAL WOODRUFF, 25X18	1	
2	19511ZE1000	FAN, COOLING	1	
4	28451ZL0801	PULLEY, STARTER	1	
5	31100ZE7010	FLYWHEEL COMP.	1	
7	90201Z0T800	NUT, SPECIAL 14MM	1	

Go to Discount-Equipment.com to order your parts

# HONDA GX200UT2QXC9 — CYLINDER HEAD ASSY.

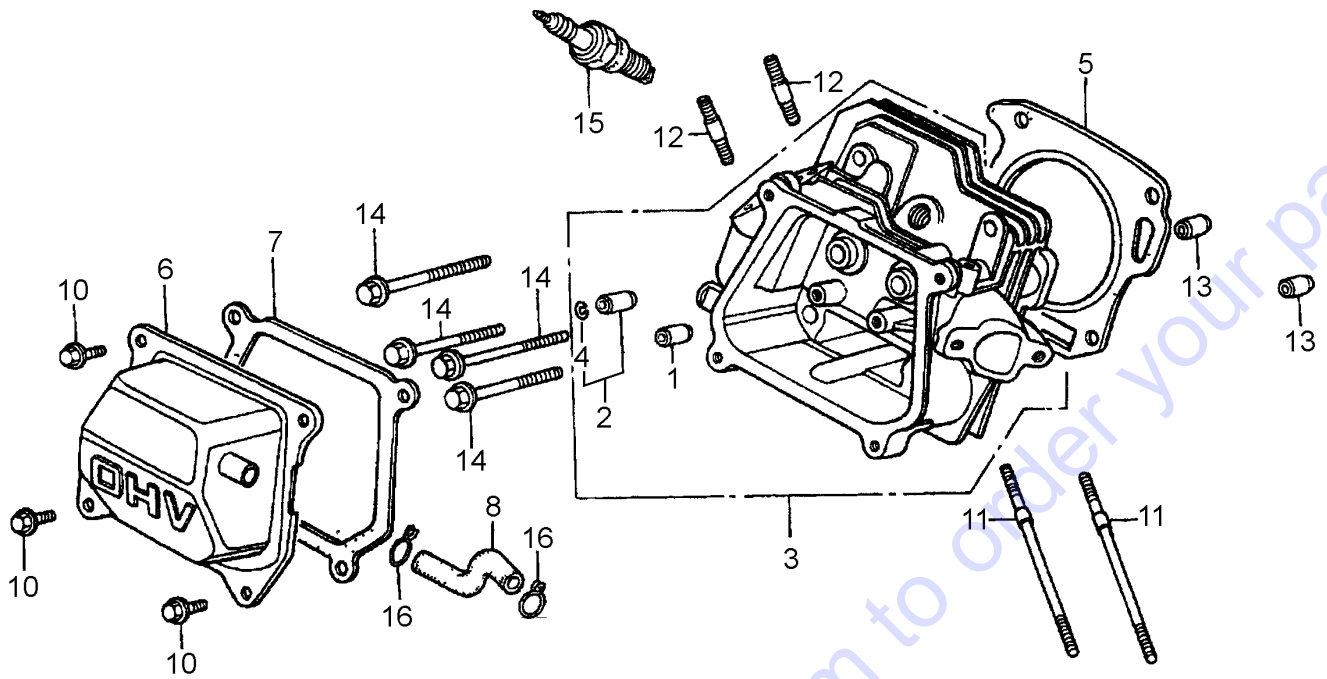

## HONDA GX200UT2QXC9 — CYLINDER HEAD ASSY.

<u>NO.</u>	<u>PART NO.</u>	<u>PART NAME</u>	<u>QTY.</u>	<u>REMARKS</u>
1#	12204ZE1306	GUIDE, IN. VALVE (O.S.)	1	
2#	12205ZE1315	GUIDE, EX. VALVE (O.S.) .....	1.....	INCLUDES ITEM W/%
3	12210ZL0415	HEAD COMP., CYLINDER .....	1.....	INCLUDES ITEMS W/#
4#%	12216ZE5300	CLIP, VALVE GUIDE	1	
5	12251ZL0003	GASKET, CYLINDER HEAD	1	
6	12310Z4M840	COVER COMP., HEAD	1	
7	12391ZE1000	PACKING, HEAD COVER	1	
8	15721ZE1840	TUBE, BREATHER	1	
10	90013883000	BOLT, FLANGE, 6X12	4	
11	90043ZE1020	BOLT, STUD, 6X112	2	
12	90047ZE1000	BOLT, STUD, 8X32	2	
13	9430110160	DOWEL PIN, 10X16	2	
14	957010806000	BOLT, FLANGE, 8X60	4	
15	9807956855	PLUG, SPARK (W20EPR-U) (DENSO)	1	
15	9807956846	PLUG, SPARK (BPR6ES) (NGK).....	1.....	REPLACES P/N 9807956876
16	9500280000	CLIP, TUBE	2	

Go to Discount-Equipment.com to order your parts

# HONDA GX200UT2QXC9 — IGNITION COIL ASSY.

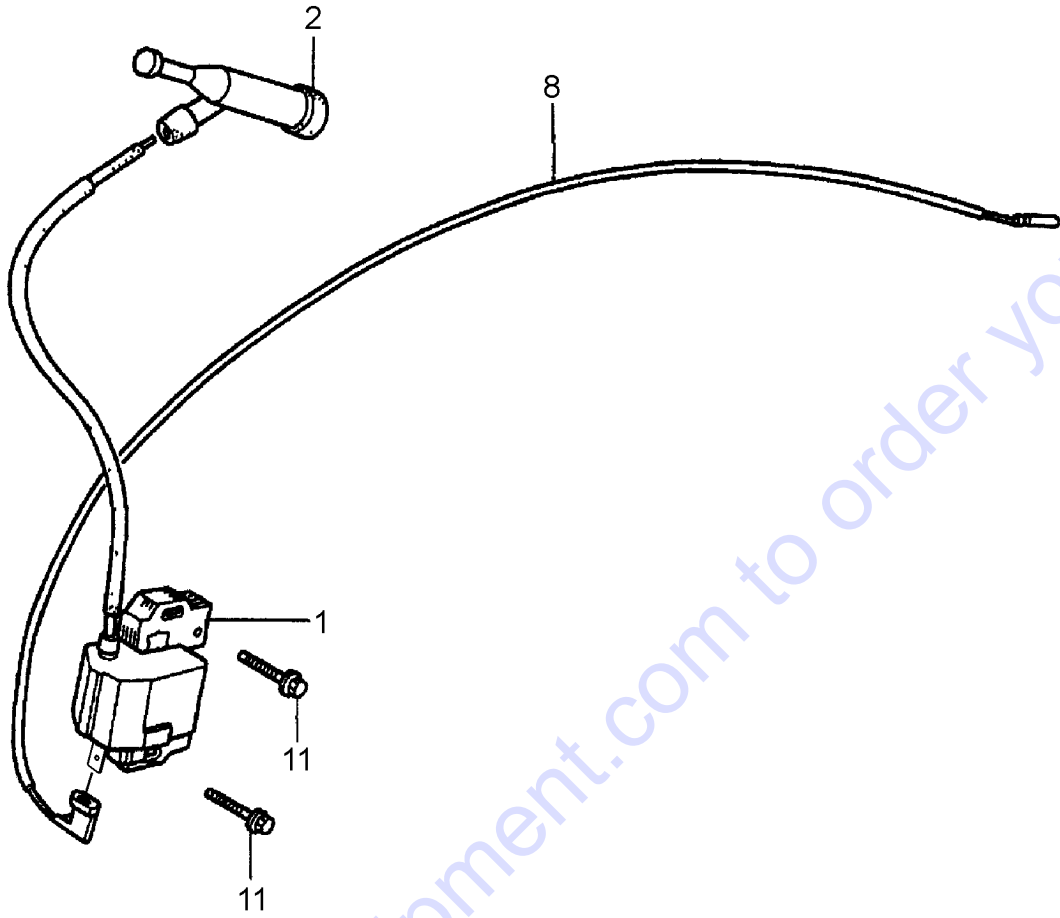

Go to Discount-Equipment.com to order your parts

## HONDA GX200UT2QXC9 — IGNITION COIL ASSY.

<u>NO.</u>	<u>PART NO.</u>	<u>PART NAME</u>	<u>QTY.</u>	<u>REMARKS</u>
1	30500Z0T802	COIL ASSEMBLY, IGNITION	1	
2	30700Z0T811	CAP ASSEMBLY, NOISE SUPPRESSOR	1	
8	36101ZE1010	CORD, STOP SWITCH (370MM)	1	
11	957010602500	BOLT, FLANGE 6X25.....	2.....	REPLACES P/N 90121952000

Go to Discount-Equipment.com to order your parts

**HONDA GX200UT2QXC9 — CONTROL ASSY.**

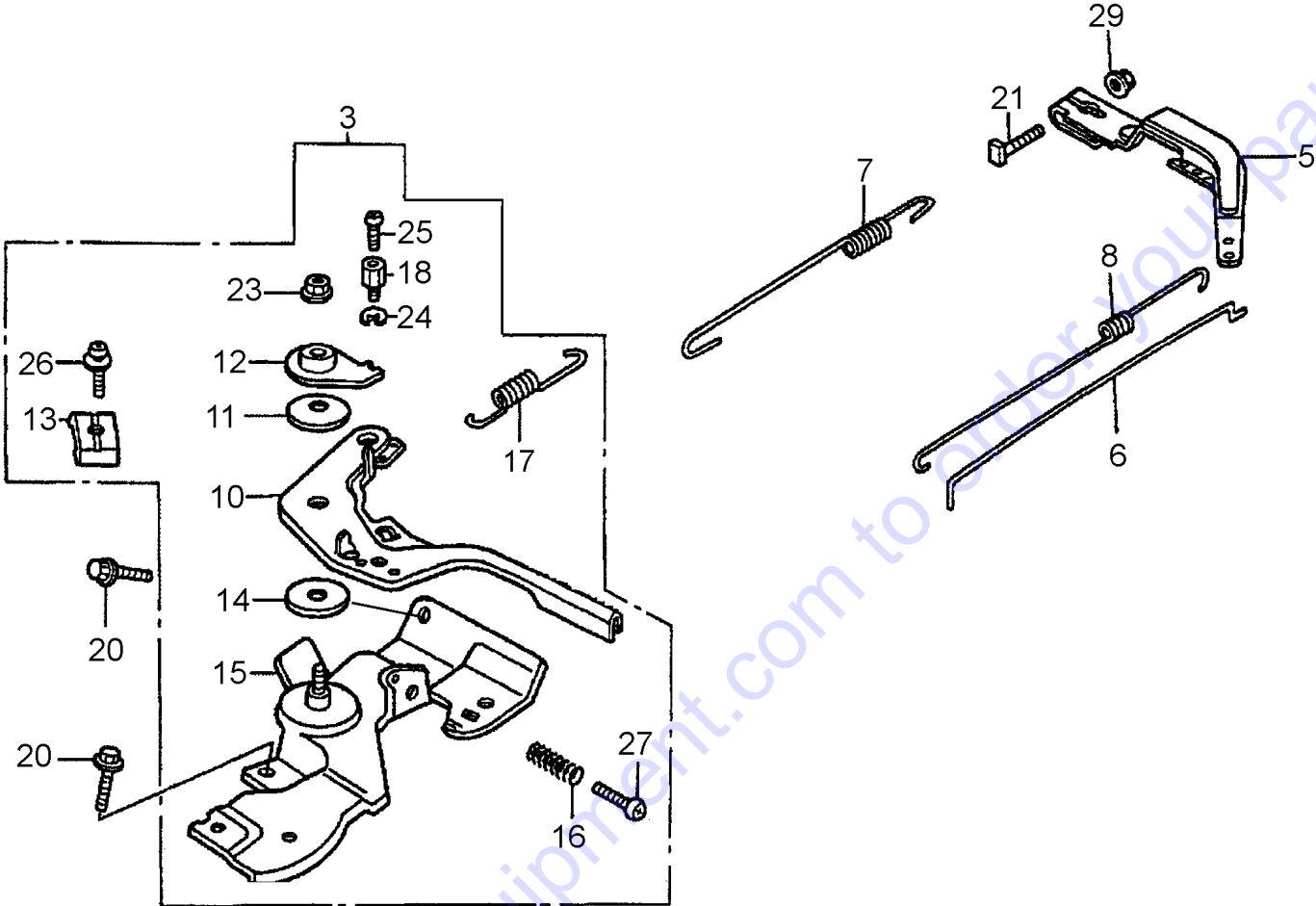

Go to Discount-Equipment.com to enter your parts

## HONDA GX200UT2QXC9 — CONTROL ASSY.

<u>NO.</u>	<u>PART NO.</u>	<u>PART NAME</u>	<u>QTY.</u>	<u>REMARKS</u>
3	16500Z4M407	CONTROL ASSY. (CYCLONE) .....	1.....	INCLUDES ITEMS W/#
5	16551ZL0000	ARM, GOVERNOR	1	
6	16555Z4M000	ROD, GOVERNOR	1	
7	16561ZL0000	SPRING, GOVERNOR	1	
8	16562ZE1020	SPRING, THROTTLE RETURN	1	
10#	16571Z4M000	LEVER, CONTROL	1	
11#	16574ZE1000	SPRING, LEVER	1	
12#	16575ZH8000	WASHER, CONTROL LEVER	1	
13#	16576891000	HOLDER, CABLE	1	
14#	16578ZE1000	SPACER, CONTROL LEVER	1	
15#	16580Z4M850	BASE COMP., CONTROL	1	
16#	16584883300	SPRING, CONTROL ADJUSTING	1	
17#	16592ZE1810	SPRING, CABLE RETURN	1	
18#	16594883010	HOLDER, WIRE	1	
20	90013883000	BOLT, FLANGE, 6X12	2	
21	90015ZE5010	BOLT, GOVERNOR ARM	1	
23#	90114SA0000	NUT, SELF-LOCK, 6MM	1	
24#	90605230000	CIRCLIP, 5MM	1	
25#	0043504060	SCREW, PAN, 4X6 .....	1.....	REPLACES P/N 93500040060H
26#	0202005T125	SCREW, PAN, 5X16 .....	1.....	REPLACES P/N 93500050160A
27#	93500050250H	SCREW, PAN, 5X25	1	
29	9405006000	NUT, FLANGE 6MM	1	

# HONDA GX200UT2QXC9 — CYLINDER BARREL ASSY.

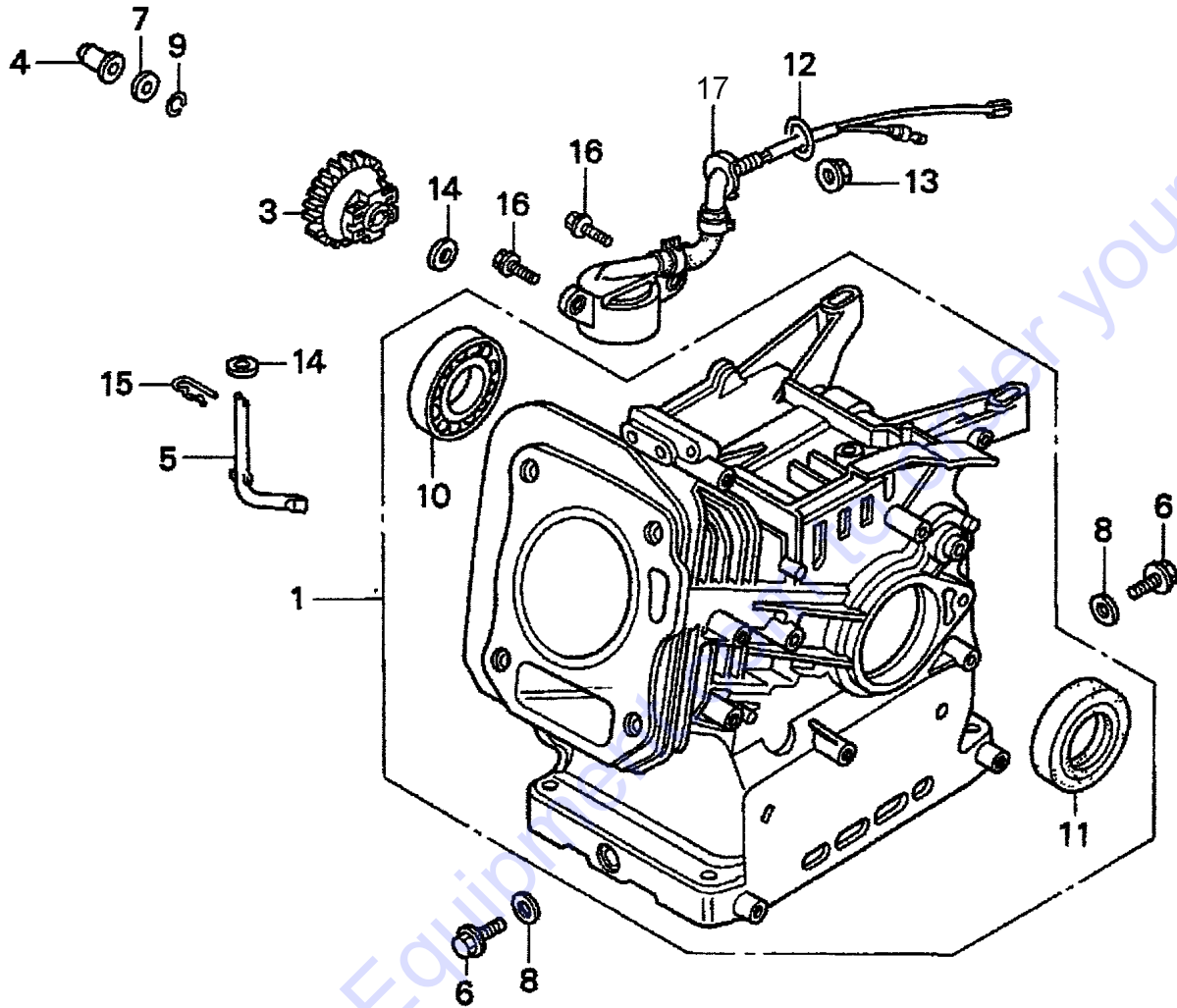



## HONDA GX200UT2QXC9 — CYLINDER BARREL ASSY.

<u>NO.</u>	<u>PART NO.</u>	<u>PART NAME</u>	<u>QTY.</u>	<u>REMARKS</u>
1	12000Z4V406	BARREL ASSY., CYLINDER .....	1.....	INCLUDES ITEMS W/#
3	16506ZL0000	GOVERNOR ASSY.	1	
4	16531ZE1000	SLIDER, GOVERNOR	1	
5	16541ZE1000	SHAFT, GOVERNOR ARM	1	
6	90131ZE1000	BOLT, DRAIN PLUG	2	
7	90451ZE1000	WASHER, THRUST, 6MM	1	
8	90601ZE1000	WASHER, DRAIN PLUG, 10.2MM	2	
9	90602ZE1000	CLIP, GOVERNOR HOLDER	1	
10#	91001ZF1003	BEARING, RADIAL BALL, (6205TMB)	1	
11#	91201ZOT801	OIL SEAL, 25X41X6	1	
12	91353671003	O-RING, 14MM.....	1.....	REPLACES P/N 91353671004
13	9405010000	NUT, FLANGE, 10MM	1	
14	58176	WASHER, FLAT 6MM.....	2.....	REPLACES P/N 9410106800
15	9425108000	PIN, LOCK, 8MM	1	
16	957010601200	BOLT, FLANGE, 6X12	2	
17	35480ZOT003	SWITCH ASSY., OIL LEVEL	1	

# HONDA GX200UT2QXC9 — CRANKCASE COVER ASSY.

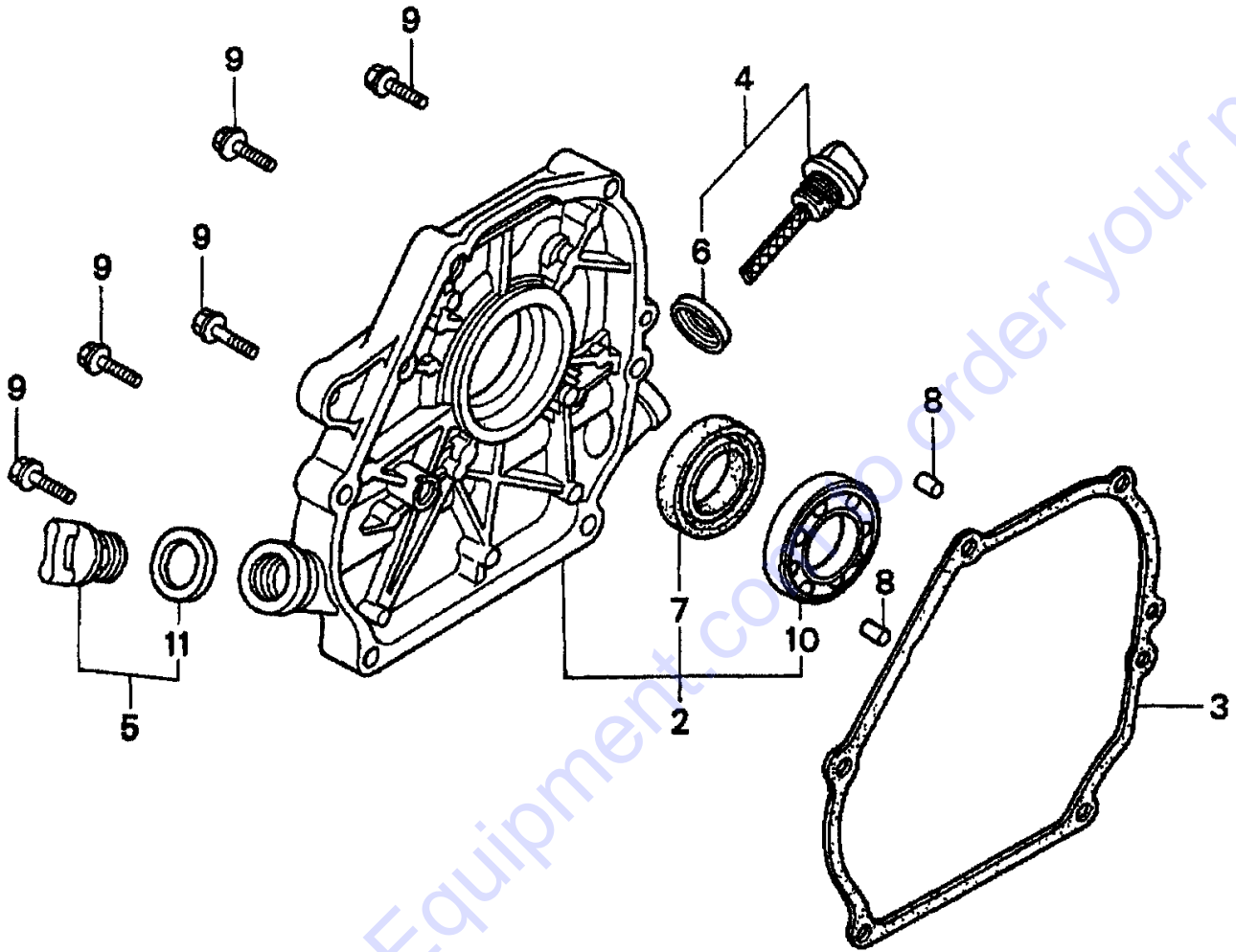

## HONDA GX200UT2QXC9 — CRANKCASE COVER ASSY.

<u>NO.</u>	<u>PART NO.</u>	<u>PART NAME</u>	<u>QTY.</u>	<u>REMARKS</u>
2	11300ZE1642	COVER ASSY., CRANKCASE.....	1.....	INCLUDES ITEMS W/#
3	11381ZH8801	PACKING, CASE COVER	1	
4	15600Z0T810	CAP ASSY., OIL FILLER .....	1.....	INCLUDES ITEMS W/\$
5	15600Z0T820	CAP ASSY., OIL FILLER .....	1.....	INCLUDES ITEMS W/%
6\$	15625Z0T800	PACKING, OIL FILLER CAP	1	
7#	91201Z0T801	OIL SEAL, 25X41X6	1	
8	9430108140	DOWEL PIN, 8X14	2	
9	957010803200	BOLT, FLANGE, 8X32	6	
10#	961006205010	BEARING, RADIAL BALL, 6205 .....	1.....	REPLACES P/N 961006205000
11%	15625Z0T800	PACKING, OIL FILLER CAP	1	

Go to Discount-Equipment.com to order your parts

# HONDA GX200UT2QXC9 — CRANKSHAFT ASSY.

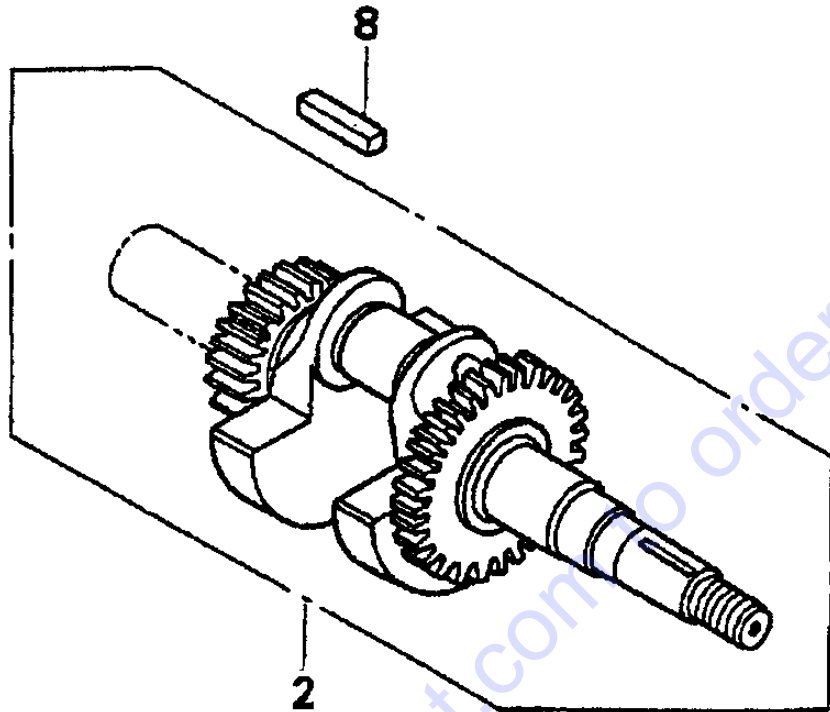

Go to Discount-Equipment.com to order your parts

## HONDA GX200UT2QXC9 — CRANKSHAFT ASSY.

---

<u>NO.</u>	<u>PART NO.</u>	<u>PART NAME</u>	<u>QTY.</u>	<u>REMARKS</u>
2	13310ZL0602	CRANKSHAFT COMP.	1	
8	90745ZE1600	KEY, 4.78X4.78X38	1	

Go to Discount-Equipment.com to order your parts

# HONDA GX200UT2QXC9 — PISTON ASSY.

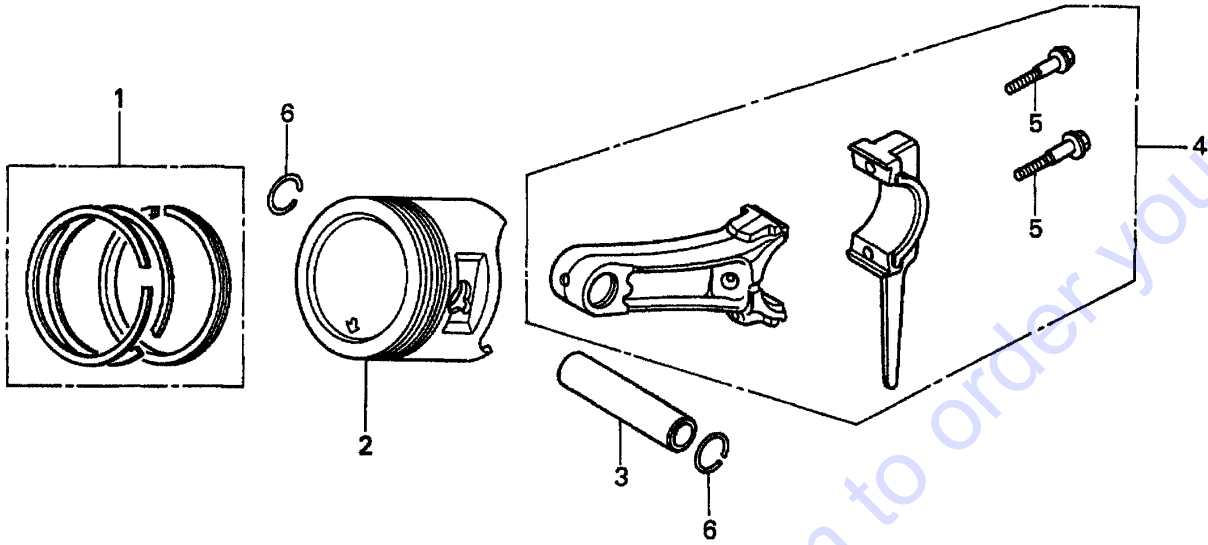

Go to Discount-Equipment.com to order your parts

## HONDA GX200UT2QXC9 — PISTON ASSY.

<u>NO.</u>	<u>PART NO.</u>	<u>PART NAME</u>	<u>QTY.</u>	<u>REMARKS</u>
1	13010Z4K004	RING SET, PISTON (STD.)	1	
1	13011Z4K004	RING SET, PISTON (0.25)	1	
1	13012Z4K004	RING SET, PISTON (0.50)	1	
1	13013Z4K004	RING SET, PISTON (0.75)	1	
2	13101Z4V800	PISTON (STD.)	1	
2	13102ZL0020	PISTON (0.25)	1	
2	13103ZL0020	PISTON (0.50)	1	
2	13104ZL0020	PISTON (0.75)	1	
3	13111Z4M000	PIN, PISTON	1	
4	13200Z0T800	ROD ASSY., CONNECTING (TH) .....	1	INCLUDES ITEMS W/#
5#	90001ZE1000	BOLT, CONNECTING ROD	2	
6	90551ZE1000	CLIP, PISTON PIN, 18MM	2	

Go to Discount-Equipment.com to order your parts

# HONDA GX200UT2QXC9 — CAMSHAFT ASSY.

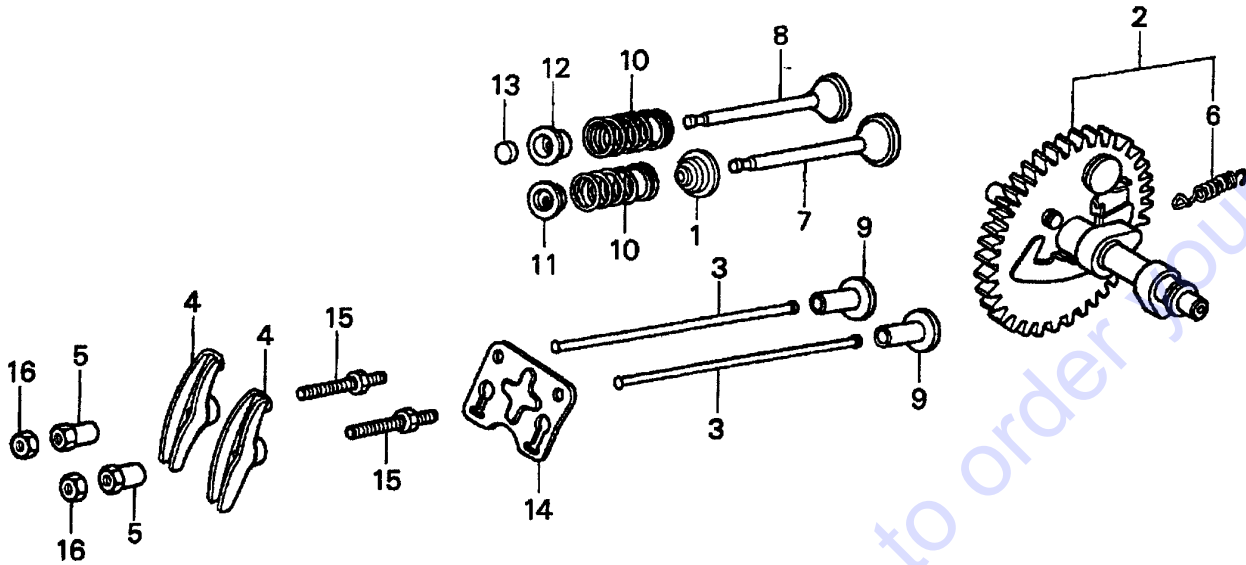

Go to Discount-Equipment.com to order your parts



## HONDA GX200UT2QXC9 — CAMSHAFT ASSY.

<u>NO.</u>	<u>PART NO.</u>	<u>PART NAME</u>	<u>QTY.</u>	<u>REMARKS</u>
1	12209Z4M801	SEAL, VALVE STEM	1	
2	14100ZL0000	CAMSHAFT ASSY.....	1	INCLUDES ITEMS W/#
3	14410ZE1010	ROD, PUSH	2	
4	14431ZE1000	ARM, VALVE ROCKER	2	
5	14451ZE1013	PIVOT, ROCKER ARM	2	
6#	14568ZE1000	SPRING, WEIGHT RETURN	1	
7	14711ZF1000	VALVE, IN.	1	
8	14721ZF1000	VALVE, EX.	1	
9	14731ZL0000	LIFTER, VALVE	2	
10	14751ZF1000	SPRING, VALVE	2	
11	14771ZE1000	RETAINER, IN. VALVE SPRING	1	
12	14773Z4X000	RETAINER, EX. VALVE SPRING	1	
13	14781ZE1000	ROTATOR, VALVE	1	
14	14791ZE1010	PLATE, PUSH ROD GUIDE	1	
15	90012ZE0010	BOLT, PIVOT, 8MM	2	
16	90206ZE1000	NUT, PIVOT ADJUSTING	2	

# HONDA GX200UT2QXC9 — LABEL ASSY.

---

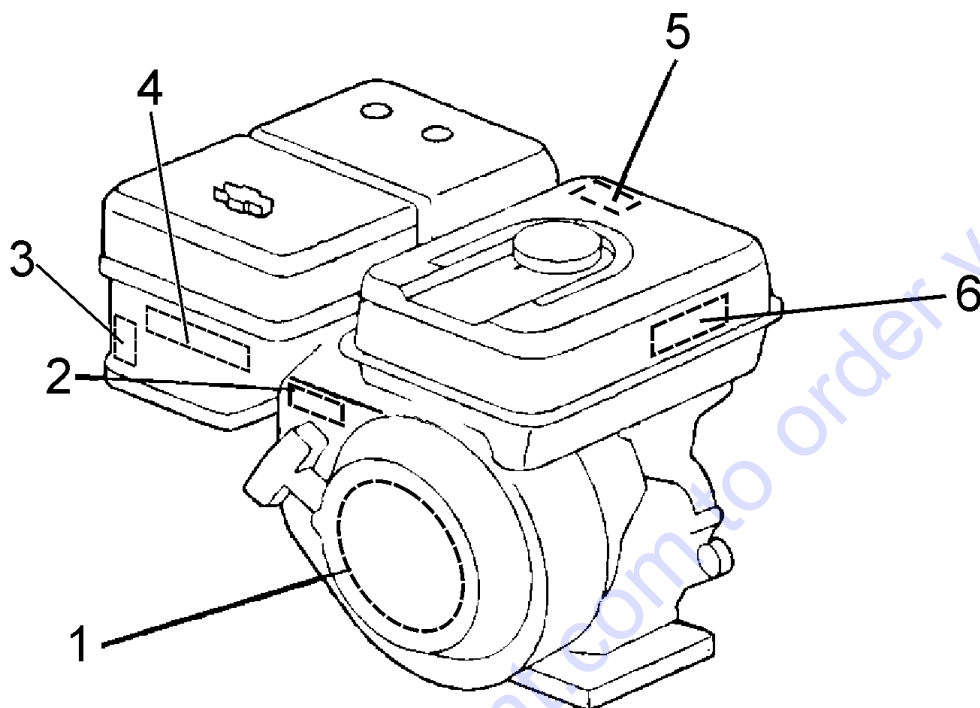

## HONDA GX200UT2QXC9 — LABEL ASSY.

<u>NO.</u>	<u>PART NO.</u>	<u>PART NAME</u>	<u>QTY.</u>	<u>REMARKS</u>
1	87521Z4V000	EMBLEM (GX200)	1	
2	87532ZH7000	MARK, THROTTLE INDICATION	1	
3	87528Z4M000	MARK, CHOKE	1	
4	87535ZE1841	MARK, AIR CLEANER	1	
5	87539Z4M000	MARK, EX, CAUTION	1	
6	87516Z4H010	MARK, OPERATOR CAUTION	1	

Go to Discount-Equipment.com to order your parts

# PARTS FINDER

**Search Website  
by Part Number**



**Search Manual  
Library For Parts  
Manual & Lookup Part  
Numbers – Purchase  
or Request Quote**

**Search Manuals**

Enter your information to help us find the right parts manual for your machine.

\* Brand:

\* Model:

\* Serial:

\* Part Number:

SEARCH

**Can't Find Part or  
Manual? Request Help  
by Manufacturer,  
Model & Description**

**Parts Order Form**

Please fill in the following information to help us find the right part for your machine.

MANUFACTURER:

MODEL:

DESCRIPTION:

DATE:

TIME:

PHONE:

EMAIL:

ADDRESS:

CITY:

STATE:

ZIP:

SEARCH

Discount-Equipment.com is your online resource for quality parts & equipment.

Florida: **561-964-4949** Outside Florida TOLL FREE: **877-690-3101**

**Need parts?**

Click on this link: <http://www.discount-equipment.com/category/5443-parts/> and choose one of the options to help get the right parts and equipment you are looking for. Please have the machine model and serial number available in order to help us get you the correct parts. If you don't find the part on the website or on one of the online manuals, please fill out the request form and one of our experienced staff members will get back to you with a quote for the right part that your machine needs.

We sell worldwide for the brands: Genie, Terex, JLG, MultiQuip, Mikasa, Essick, Whiteman, Mayco, Toro Stone, Diamond Products, Generac Magnum, Airman, Haulotte, Barreto, Power Blanket, Nifty Lift, Atlas Copco, Chicago Pneumatic, Allmand, Miller Curber, Skyjack, Lull, Skytrak, Tsurumi, Husquvarna Target, Stow, Wacker, Sakai, Mi-T-M, Sullair, Basic, Dynapac, MBW, Weber, Bartell, Bennar Newman, Haulotte, Ditch Runner, Menegotti, Morrison, Contec, Buddy, Crown, Edco, Wyco, Bomag, Laymor, EZ Trench, Bil-Jax, F.S. Curtis, Gehl Pavers, Heli, Honda, ICS/PowerGrit, IHI, Partner, Imer, Clipper, MMD, Koshin, Rice, CH&E, General Equipment, Amida, Coleman, NAC, Gradall, Square Shooter, Kent, Stanley, Tamco, Toku, Hatz, Kohler, Robin, Wisconsin, Northrock, Oztec, Toker TK, Rol-Air, APT, Wylie, Ingersoll Rand / Doosan, Innovatech, Con X, Ammann, Mecalac, Makinex, Smith Surface Prep, Small Line, Wanco, Yanmar