

# OPERATION AND PARTS MANUAL



## **MODEL GAW180HE/HE1/HEA PORTABLE WELDER-GENERATOR (HONDA GX340K1EDE2/GX340RT2EDE2 GASOLINE ENGINES)**

Revision #1 (10/01/19)



THIS MANUAL MUST ACCOMPANY THE EQUIPMENT AT ALL TIMES.

# PARTS FINDER

**Search Website  
by Part Number**



**Search Manual  
Library For Parts  
Manual & Lookup Part  
Numbers – Purchase  
or Request Quote**

**Search Manuals**

Enter your information to help us find the right parts manual for your machine.

\* Brand:

\* Model:

\* Serial:

\* Part Number:

SEARCH

**Can't Find Part or  
Manual? Request Help  
by Manufacturer,  
Model & Description**

**Parts Order Form**

Please fill in the following information to help us find the right part for your machine.

Manufacturer:	<input type="text"/>
Model:	<input type="text"/>
Description:	<input type="text"/>
Part Number:	<input type="text"/>
Quantity:	<input type="text"/>
Notes:	<input type="text"/>

Submit

Discount-Equipment.com is your online resource for quality parts & equipment.

Florida: **561-964-4949** Outside Florida TOLL FREE: **877-690-3101**

**Need parts?**

Click on this link: <http://www.discount-equipment.com/category/5443-parts/> and choose one of the options to help get the right parts and equipment you are looking for. Please have the machine model and serial number available in order to help us get you the correct parts. If you don't find the part on the website or on one of the online manuals, please fill out the request form and one of our experienced staff members will get back to you with a quote for the right part that your machine needs.

We sell worldwide for the brands: Genie, Terex, JLG, MultiQuip, Mikasa, Essick, Whiteman, Mayco, Toro Stone, Diamond Products, Generac Magnum, Airman, Haulotte, Barreto, Power Blanket, Nifty Lift, Atlas Copco, Chicago Pneumatic, Allmand, Miller Curber, Skyjack, Lull, Skytrak, Tsurumi, Husquvarna Target, Stow, Wacker, Sakai, Mi-T-M, Sullair, Basic, Dynapac, MBW, Weber, Bartell, Bennar Newman, Haulotte, Ditch Runner, Menegotti, Morrison, Contec, Buddy, Crown, Edco, Wyco, Bomag, Laymor, EZ Trench, Bil-Jax, F.S. Curtis, Gehl Pavers, Heli, Honda, ICS/PowerGrit, IHI, Partner, Imer, Clipper, MMD, Koshin, Rice, CH&E, General Equipment, Amida, Coleman, NAC, Gradall, Square Shooter, Kent, Stanley, Tamco, Toku, Hatz, Kohler, Robin, Wisconsin, Northrock, Oztec, Toker TK, Rol-Air, APT, Wylie, Ingersoll Rand / Doosan, Innovatech, Con X, Ammann, Mecalac, Makinex, Smith Surface Prep, Small Line, Wanco, Yanmar

## PROPOSITION 65/START FIRES WARNING

---

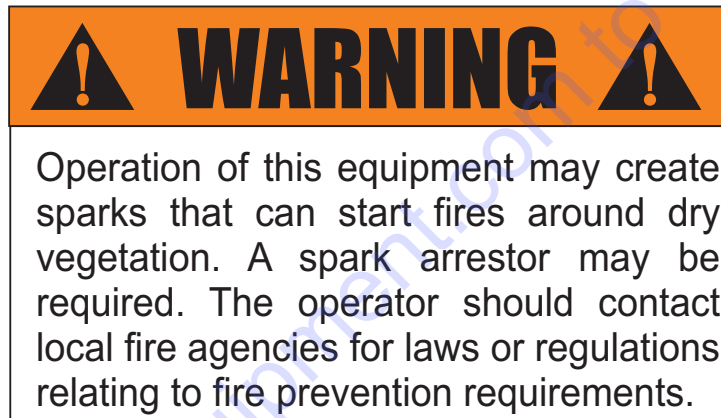

# TABLE OF CONTENTS

## GAW180HE Series 60 Hz Welder-Generator

Proposition 65/Start Fires Warning.....	2
Table of Contents.....	3
Nameplate/Safety Information.....	4
Safety Information.....	6–13
Specifications (Welder-Generator).....	14
Specifications (Engine).....	15
Dimensions.....	16
Installation.....	17–18
General Information.....	19
Welding Polarity and Duty Cycle.....	20
Welding Terms.....	21
Components Generator.....	22
Components Generator (Continued).....	23
Inspection/Setup.....	24–26
Operation.....	27–29
Preparation for Long Term Storage.....	30
Maintenance.....	31–35
Welder/Generator Wiring Diagram.....	36
Troubleshooting (Welder/Generator).....	37–38
Troubleshooting (Engine).....	40–41
Explanation of Code in Remarks Column.....	42
Suggested Spare Parts.....	43

## Component Drawings

Nameplate and Decals Assembly.....	44–45
Generator Assembly.....	46–47
Control Box Assembly.....	48–51
Pipe Frame Assembly.....	52–55
Battery Assembly.....	56–57
Muffler Assembly.....	58–59
UWKB Wheel Kit Assembly (Option).....	60–61

## Honda GX340K1EDE2/EDE2 Gasoline Engine

Air Cleaner Assembly (GX340K1EDE2).....	62–63
Air Cleaner Assembly (GX340RT2EDE2).....	64–65
Camshaft Assembly.....	66–67
Carburetor Assembly.....	68–71
Control Assembly.....	72–73
Crankcase Cover Assembly.....	74–75
Crankshaft Assembly.....	76–77
Cylinder Barrel Assembly.....	78–79
Cylinder Head Assembly.....	80–81
Fan Cover Assembly.....	82–83
Flywheel Assembly.....	84–85
Ignition Coil Assembly.....	86–87
Piston Assembly.....	88–89
Recoil Starter Assembly.....	90–91
Starter Motor Assembly.....	92–93
Solenoid Assembly.....	94–95
Engine Decals Assembly.....	96–97

### NOTICE

Specifications and part numbers are subject to change without notice.

# NAMEPLATE/SAFETY INFORMATION

## NAMEPLATE AND SAFETY LABELS

Safety labels are attached to the generator as shown in Figure 1. Keep these safety labels clean at all times. When the safety labels become worn or damaged, contact Discount-equipment.

**NOTICE**  
For safety label part numbers, reference the parts section of this manual.

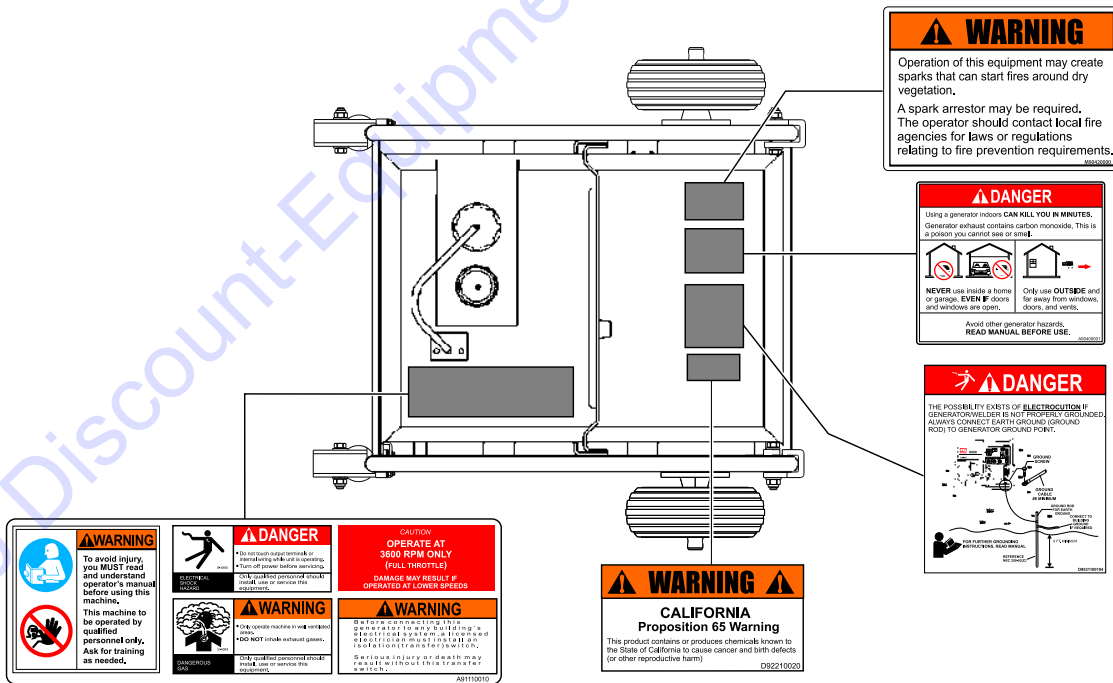
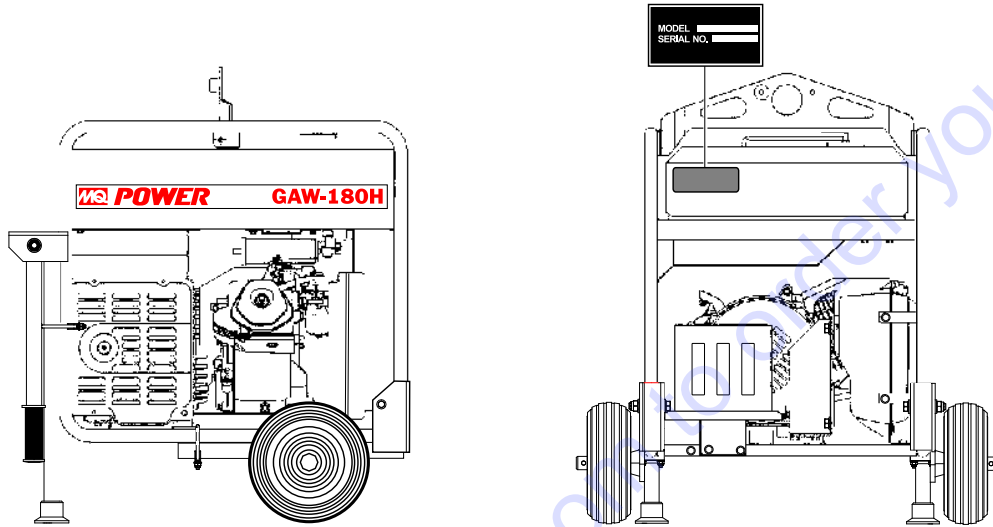

Figure 1. Nameplate and Safety Decals

# SAFETY INFORMATION

**DO NOT** operate or service the equipment before reading the entire manual. Safety precautions should be followed at all times when operating this equipment. Failure to read and understand the safety messages and operating instructions could result in injury to yourself and others.



## SAFETY MESSAGES

The four safety messages shown below will inform you about potential hazards that could injure you or others. The safety messages specifically address the level of exposure to the operator and are preceded by one of four words: **DANGER**, **WARNING**, **CAUTION** or **NOTICE**.

## SAFETY SYMBOLS

<b>DANGER</b>
Indicates a hazardous situation which, if not avoided, <b>WILL</b> result in <b>DEATH</b> or <b>SERIOUS INJURY</b> .
<b>WARNING</b>
Indicates a hazardous situation which, if not avoided, <b>COULD</b> result in <b>DEATH</b> or <b>SERIOUS INJURY</b> .
<b>CAUTION</b>
Indicates a hazardous situation which, if not avoided, <b>COULD</b> result in <b>MINOR</b> or <b>MODERATE INJURY</b> .
<b>NOTICE</b>
Addresses practices not related to personal injury.

Potential hazards associated with the operation of this equipment will be referenced with hazard symbols which may appear throughout this manual in conjunction with safety messages.

Symbol	Safety Hazard
	Lethal Exhaust Gas Hazards
	Explosive Fuel Hazards
	Burn Hazards
	Welding Hazards
	EMF Hazards
	Pacemaker Hazards
	Implant Hazards
	Flying Sparks Hazards
	Fire Hazards
	Electric Shock Hazards

# SAFETY INFORMATION

## GENERAL SAFETY

### CAUTION

- **NEVER** operate this equipment without proper protective clothing, shatterproof glasses, respiratory protection, hearing protection, steel-toed boots and other protective devices required by the job or city and state regulations.



- **NEVER** operate this equipment when not feeling well due to fatigue, illness or when under medication.



- **NEVER** operate this equipment under the influence of drugs or alcohol.



### NOTICE



- This equipment should only be operated by trained and qualified personnel 18 years of age and older.
- Whenever necessary, replace nameplate, operation and safety decals when they become difficult read.
- Manufacturer does not assume responsibility for any accident due to equipment modifications. Unauthorized equipment modification will void all warranties.
- **NEVER** use accessories or attachments that are not recommended by Multiquip for this equipment. Damage to the equipment and/or injury to user may result.
- **ALWAYS** know the location of the nearest **fire extinguisher**.
- **ALWAYS** know the location of the nearest **first aid kit**.
- **ALWAYS** know the location of the nearest phone or **keep a phone on the job site**. Also, know the phone numbers of the nearest **ambulance, doctor and fire department**. This information will be invaluable in the case of an emergency.



# SAFETY INFORMATION

## WELDER SAFETY

### DANGER

- **NEVER** install or operate the welder-generator in an explosive atmosphere or near combustible materials. An explosion or fire could result causing severe **bodily harm or even death**. 
- Flying sparks can cause injury. Wear a face shield to protect eyes and face. 
- Remove all flammables within 35 ft (10.7 m) of welding arc. If this is not possible, tightly cover them with approved covers.
- Do not weld where flying sparks can strike flammable material.
- Hot metal from air arc cutting and gouging can cause fire or explosion. **DO NOT** cut or gouge near flammables. 
- Welding on closed containers, like tanks, drums or pipes, can cause them to blow up. **DO NOT** weld on closed containers unless they are properly prepared according to AWS F4.1 (see *Recommended Safe Practices for the Preparation for Welding and Cutting of Containers and Piping* from American Welding Society Standards). Check and be sure area is safe before doing any welding.
- Protect yourself and others from flying sparks and hot metal. Wear oil-free protective garments like leather gloves, heavy shirt, cuffless trousers, high shoes and a cap.
- Be alert that welding sparks and hot materials from welding can go through small cracks and openings to adjacent areas.
- Be aware that welding on a ceiling, floor, bulkhead or partition can cause fire on hidden side.
- Connect welding cable to the work as close to welding area as practical to prevent welding current from traveling long, possibly unknown paths and causing electric shock, sparks and fire hazards.
- **DO NOT** use welder-generator to thaw frozen pipes.
- Remove stick electrode from holder or cut off welding wire at contact tip when not in use.

- **DO NOT** touch output terminals during operation. Contact with output terminals during operation can cause **electrocution, electrical shock or burn**.
- Remove any combustibles, such as a butane lighter or matches, from your person before doing any welding.
- After completion of work, inspect area to ensure it is free of sparks, glowing embers and flames.
- Follow requirements in OSHA 1910.252 (a) (2) (iv) and NFPA 51B for hot work and have a fire watcher and extinguisher nearby.



### WARNING

- Keep your head out of the fumes. Use enough ventilation or exhaust at the arc, or both, to keep the fumes and gases from your breathing zone and the general area. In a large room or outdoors, natural ventilation may be adequate if you keep your head out of the fumes.
- **DO NOT** get too close to the arc. Use corrective lenses if necessary to stay a reasonable distance away from the arc.
- Use natural drafts or fans to keep the fumes away from your face.
- Welding wire can cause injury. Do not press gun trigger until instructed to do so. Do not point gun toward any part of the body, other people or any metal when threading welding wire. 
- Have only qualified people remove doors, panels, covers or guards for maintenance and troubleshooting if necessary.
- Reinstall doors, panels, covers or guards when servicing is finished and before starting engine.
- **NEVER** disconnect any **emergency or safety devices**. These devices are intended for operator safety. Disconnection of these devices can cause severe injury, bodily harm or even death. Disconnection of any of these devices will void all warranties.



## SAFETY INFORMATION

### CAUTION

- Electric current flowing through any conductor causes localized Electro Magnetic Fields (EMF). Welding current creates EMF fields around welding cables and welding machines. 
- Wearers of **pacemakers** and other implanted medical devices should keep away from welding equipment when in use. 
- Implanted medical device wearers should consult their doctor and the device manufacturer before going near arc welding, spot welding, gouging, plasma arc cutting or induction heating operations. 
- Exposure to EMF fields in welding may have other health effects which are now not known.
- All welders should use the following procedures in order to minimize exposure to EMF fields from the welding circuit:
  - Route the electrode and work cables together. Secure them with tape when possible.
  - **NEVER** coil the electrode lead around your body.
  - **DO NOT** place your body between the electrode and work cables. If the electrode cable is on your right side, the work cable should also be on your right side.
  - Connect the work cable to the workpiece as close as possible to the area being welded.
  - **DO NOT** work next to the welder-generator.

### NOTICE

- Electromagnetic energy can interfere with sensitive electronic equipment such as microprocessors, computers and computer-driven equipment such as robots. Be sure all equipment in the welding area is electromagnetically compatible. 
- To reduce possible interference, keep weld cables as short as possible, close together and down low, such as on the floor. Locate welding operation 100 meters from any sensitive electronic equipment. Be sure welder-generator is installed and grounded according to this manual.
- If interference still occurs, the operator must take extra measures, like moving the welder-generator, using shielded cables, using line filters or shielding the work area.
- **NEVER** lubricate components or attempt service on a running machine.
- Overheating can damage equipment. Turn off or unplug equipment before starting or stopping engine. Low voltage and frequency caused by low engine speed can damage electric devices. Ensure engine speed is correct during operation.
- Overloading shortens the life of the welder-generator. Use the machine with appropriate AC and DC current and appropriate duty cycle.
- **ALWAYS** ensure welder-generator is on level ground before use.
- **ALWAYS** keep the welder-generator in proper running condition.
- Fix damage to welder-generator and replace any broken parts immediately.
- **ALWAYS** store welder-generator properly when it is not being used. Equipment should be stored in a clean, dry location out of the reach of children and unauthorized personnel.

# SAFETY INFORMATION

## ENGINE SAFETY

### DANGER

- The engine fuel exhaust gases contain poisonous carbon monoxide. This gas is colorless and odorless, and can cause death if inhaled.
- The engine of this equipment requires an adequate free flow of cooling air. **NEVER** operate this equipment in any enclosed or narrow area where free flow of the air is restricted. If the air flow is restricted it will cause injury to people and property and serious damage to the equipment or engine.

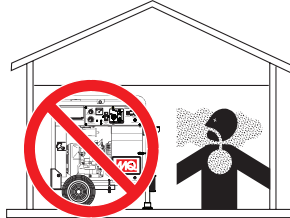

### WARNING

- **NEVER** operate the engine with heat shields or guards removed.
- **DO NOT** remove the engine oil drain plug while the engine is hot. Hot oil will gush out of the engine crankcase and severely scald any persons in the general area of the generator.

### CAUTION

- **NEVER** touch the hot exhaust manifold, muffler or cylinder. Allow these parts to cool before servicing equipment.



### NOTICE

- **NEVER** run engine without an air filter or with a dirty air filter. Severe engine damage may occur. Service air filter frequently to prevent engine malfunction.
- **NEVER** tamper with the factory settings of the engine or engine governor. Damage to the engine or equipment can result if operating in speed ranges above the maximum allowable.
- State Health Safety Codes and Public Resources Codes specify that in certain locations, spark arresters must be used on internal combustion engines that use hydrocarbon fuels. A spark arrester is a device designed to prevent accidental discharge of sparks or flames from the engine exhaust. Spark arresters are qualified



and rated by the United States Forest Service for this purpose. In order to comply with local laws regarding spark arresters, consult the engine distributor or the local Health and Safety Administrator.

## FUEL SAFETY

### DANGER

- **DO NOT** add fuel to equipment if it is placed inside truck bed with plastic liner. Possibility exists of explosion or fire due to static electricity.

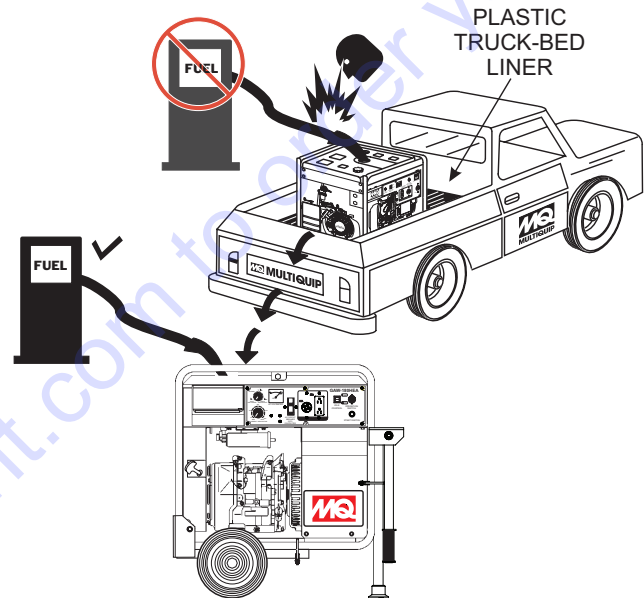

- **DO NOT** start the engine near spilled fuel or combustible fluids. Gasoline fuel is extremely flammable and its vapors can cause an explosion if ignited.
- **ALWAYS** refuel in a well-ventilated area, away from sparks and open flames.
- **ALWAYS** use extreme caution when working with **flammable** liquids.
- **DO NOT** fill the fuel tank while the engine is running or hot.
- **DO NOT** overfill tank, since spilled fuel could ignite if it comes into contact with hot engine parts or sparks from the ignition system.
- Store fuel in appropriate containers, in well-ventilated areas and away from sparks and flames.

# SAFETY INFORMATION

- **NEVER** use fuel as a cleaning agent.
- **DO NOT** smoke around or near the equipment. Fire or explosion could result from fuel vapors or if fuel is spilled on a hot engine



## ELECTRICAL SAFETY

### DANGER

- Turn welder-generator and all circuit breakers **OFF** before performing maintenance on the generator or making contact with output receptacles.
- **NEVER** insert any objects into the output receptacles during operation. This is extremely dangerous. The possibility exists of **electrical shock, electrocution or death.**
- Backfeed to a utility system can cause **electrocution** and/or property damage. **NEVER** connect the welder-generator to a building's electrical system without a transfer switch or other approved device. All installations should be performed by a **licensed electrician** in accordance with all applicable laws and electrical codes. Failure to do so could result in electrical shock or burn, causing **serious injury or even death.**



## Power Cord/Cable Safety

### DANGER

- **NEVER** let power cords or cables **lay in water.**
- **NEVER stand in water** while AC or DC power from the generator is being transferred to a load.
- **NEVER** use **damaged** or **worn** cables or cords when connecting equipment to generator. Inspect for cuts in the insulation.
- **NEVER** grab or touch a live power cord or cable with wet hands. The possibility exists of **electrical shock, electrocution or death.**
- Make sure power cables are securely connected to the generator's output receptacles. Incorrect connections may cause electrical shock and damage to the generator.

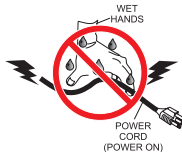

## NOTICE

- **ALWAYS** make certain that proper power or extension cord has been selected for the job. See Cable Selection Chart in this manual.

## Grounding Safety

### DANGER

- These welder-generators are equipped with a grounding terminal at the base of the pipe frame. Electrical grounding requirements can differ by State, Province, District, Municipality, and unique application settings.
- For portable and vehicle-mounted welder-generators, Multiquip recognizes the guidance provided in NEC Handbook Article 250.34 Parts A and B, and 29 CFR 1926.404 (f) (3) (i). If a more definitive earth-to-ground safeguard is required, please consult a qualified electrician and reference appropriate National Electrical Code (NEC) guidelines in establishing an exterior grounding point
- **NEVER** use gas piping as an electrical ground.

## BATTERY SAFETY

### DANGER

- **DO NOT** drop the battery. There is a possibility that the battery will explode.
- **DO NOT** expose the battery to open flames, sparks, cigarettes, etc. The battery contains combustible gases and liquids. If these gases and liquids come into contact with a flame or spark, an explosion could occur.
- **DO NOT** charge battery if frozen. Battery can explode. When frozen, warm the battery to at least 61°F (16°C)



### WARNING

- **ALWAYS** wear safety glasses when handling the battery to avoid eye irritation. The battery contains acids that can cause injury to the eyes and skin.
- Use well-insulated gloves when picking up the battery.
- **ALWAYS** keep the battery charged. If the battery is not charged, combustible gas will build up.



# SAFETY INFORMATION

- **ALWAYS** recharge the battery in a well-ventilated environment to avoid the risk of a dangerous concentration of combustible gasses..
- If the battery liquid (dilute sulfuric acid) comes into contact with **clothing or skin**, rinse skin or clothing immediately with plenty of water.
- If the battery liquid (dilute sulfuric acid) comes into contact with **eyes**, rinse eyes immediately with plenty of water and contact the nearest doctor or hospital to seek medical attention.

## ⚠ CAUTION

- **ALWAYS** disconnect the **NEGATIVE** battery terminal before performing service on the generator.
- **ALWAYS** keep battery cables in good working condition. Repair or replace all worn cables.

## TRANSPORTING SAFETY

### ⚠ CAUTION

- **NEVER** allow any person or animal to stand underneath the equipment while lifting.

### NOTICE

- Before lifting, make sure that the equipment parts (lifting bail) is not damaged and screws are not loose or missing.
- **ALWAYS** make sure crane or lifting device has been properly secured to the lifting bail (hook) of the equipment.
- **ALWAYS** shutdown engine before transporting.
- **NEVER** lift the equipment while the engine is running.
- Tighten fuel tank cap securely and close fuel cock to prevent fuel from spilling.
- Use adequate lifting cable (wire or rope) of sufficient strength.
- Use one point suspension hook and lift straight upwards.

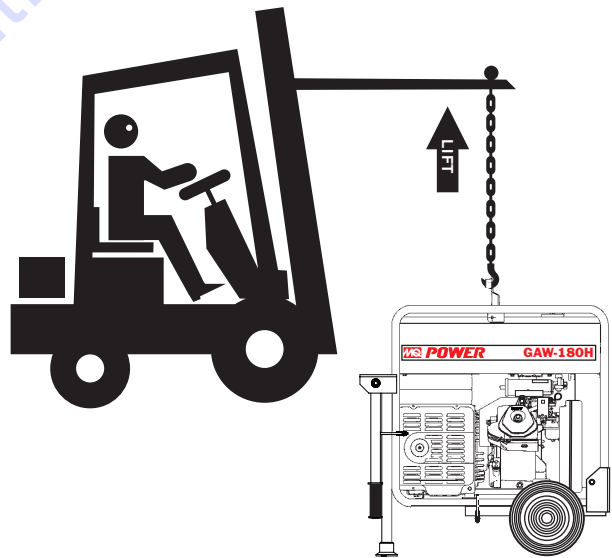

- **DO NOT** lift machine to unnecessary heights.
- **ALWAYS** tie down equipment during transport by securing the equipment with rope.

# SAFETY INFORMATION

## ENVIRONMENTAL SAFETY/DECOMMISSIONING

### NOTICE

Decommissioning is a controlled process used to safely retire a piece of equipment that is no longer serviceable. If the equipment poses an unacceptable and unrepairable safety risk due to wear or damage or is no longer cost effective to maintain (beyond life-cycle reliability) and is to be decommissioned (demolition and dismantlement), be sure to follow rules below.

- **DO NOT** pour waste or oil directly onto the ground, down a drain or into any water source.
- Contact your country's Department of Public Works or recycling agency in your area and arrange for proper disposal of any electrical components, waste or oil associated with this equipment.
- When the life cycle of this equipment is over, remove battery (if equipped) and bring to appropriate facility for lead reclamation. Use safety precautions when handling batteries that contain sulfuric acid.
- When the life cycle of this equipment is over, it is recommended that the unit frame and all other metal parts be sent to a recycling center.



Metal recycling involves the collection of metal from discarded products and its transformation into raw materials to use in manufacturing a new product.

Recyclers and manufacturers alike promote the process of recycling metal. Using a metal recycling center promotes energy cost savings.

## EMISSIONS INFORMATION

### NOTICE

The gasoline engine used in this equipment has been designed to reduce harmful levels of carbon monoxide (CO), hydrocarbons (HC) and nitrogen oxides (NOx) contained in gasoline exhaust emissions.

This engine has been certified to meet US EPA Evaporative emissions requirements in the installed configuration.

Attempting to modify or make adjustments to the engine emission system by unauthorized personnel without proper training could damage the equipment or create an unsafe condition.

Additionally, modifying the fuel system may adversely affect evaporative emissions, resulting in fines or other penalties.

### Emission Control Label

The emission control label is an integral part of the emission system and is strictly controlled by regulation(s).

The label must remain with the engine for its entire life.

If a replacement emission label is needed, please contact Discount-equipment.

## SPECIFICATIONS (WELDER-GENERATOR)

Table 1. Specifications (Welder-Generator)			
<b>DC ARC Welder</b>	Model	GAW180HE	GAW180HEA
	Rated Output	4.56 kW	
	Max Current	180 amps	
	Rated Current	170 amps	
	Rated Voltage	26.8	
	Duty Cycle	50%	
	Current Range	30 ~ 180 amps	
	Applicable Electrode Size	3/32 ~ 5/32"	
	Welding Applications	SMAW, FCAW, GMAW, GTAW and ACAC	
<b>60 Hz Generator</b>	Rated Output	3.0 kW	
	Rated Voltage	120V	
	Rated Current	25 amps	
	Phase	Single Phase (3 wire)	
	Frequency	60 Hz	
	Power Factor	1	
<b>Dimensions (L x W x H)</b>		27.6 x 25.6 X 22 in. (701 X 650 X 559 mm)	28 x 22 X 26 in. (711 X 559 X 755 mm)
<b>Dry Net Weight</b>		236 lbs. (107 kg.)	
<b>Weight With Fuel</b>		265 lbs. (120 kg.)	
<b>Battery</b>		12 volts, 26 Amp hours, 260 amps cold cranking ability : 7-1/2" (L) X 5"(W) X 7-1/4"(H)	

### NOTICE

In keeping with Multiquip's policy of constantly improving its products, the specifications quoted herein are subject to change without prior notice.

## SPECIFICATIONS (ENGINE)

<b>Table 2. Specifications (Engine)</b>				
<b>Engine</b>	<b>Model</b>	<b>HONDA GX340K1EDN2</b>	<b>HONDA GX340RT2EDE2</b>	
	Type	Air-cooled 4 stroke, Single Cylinder, OHV, Horizontal Shaft Gasoline Engine		
	Bore X Stroke	2.90 in. X 2.30 in. (73 mm x 58 mm.)	3.46 in. X 2.52 in. (88 mm x 64 mm.)	
	Displacement	23.70 cu-in (389 cm <sup>3</sup> )		
	Max Output	9.5 H.P./3600 R.P.M.	10.7 H.P./3600 R.P.M	
	Rated Output	7.8 H.P./3600 R.P.M.	8.4 H.P./3600 R.P.M.	
	Fuel	Unleaded Gasoline 86 Octane or Higher		
	Fuel Capacity	3.7 gal. (14 liters)		
	Lube Oil Capacity	1.16 quarts (1.1 liters)		
	Oil Alert System	Yes		
	Speed Control Method	Centrifugal Fly-weight Type		
	Starting Method	Electric Start ~ Recoil Start		
<b>Dimensions (L x W x H)</b>		15.0 x 17.7 X 17.4 in. (380 X 450 X 443 mm)	16 x 19.1 X 17.7 in. (407 X 485 X 449 mm)	
<b>Dry Net Weight</b>		68.4 lbs. (31 kg.)	69 lbs. (31.5 kg.)	

### Effects of Altitude and Heat

The maximum output of the engines listed above are applicable to supplying electrical power for continuous service at ambient conditions in accordance with SAE Test cord J607. The above ambient conditions are at standard sea level, with a barometric reading of 29.92 inches and a temperature of 60° F (15.5° C).

Generally, the engine's output power will decrease 3-1/2% for each 1000 feet (305 meters) of altitude above sea level, and 1% for each 10° F (-12.2° C) above the standard temperature of 60° F (15.5° C).

# DIMENSIONS

## NOTICE

UWKB Wheel Kit is optional. Contact Discount-equipment.

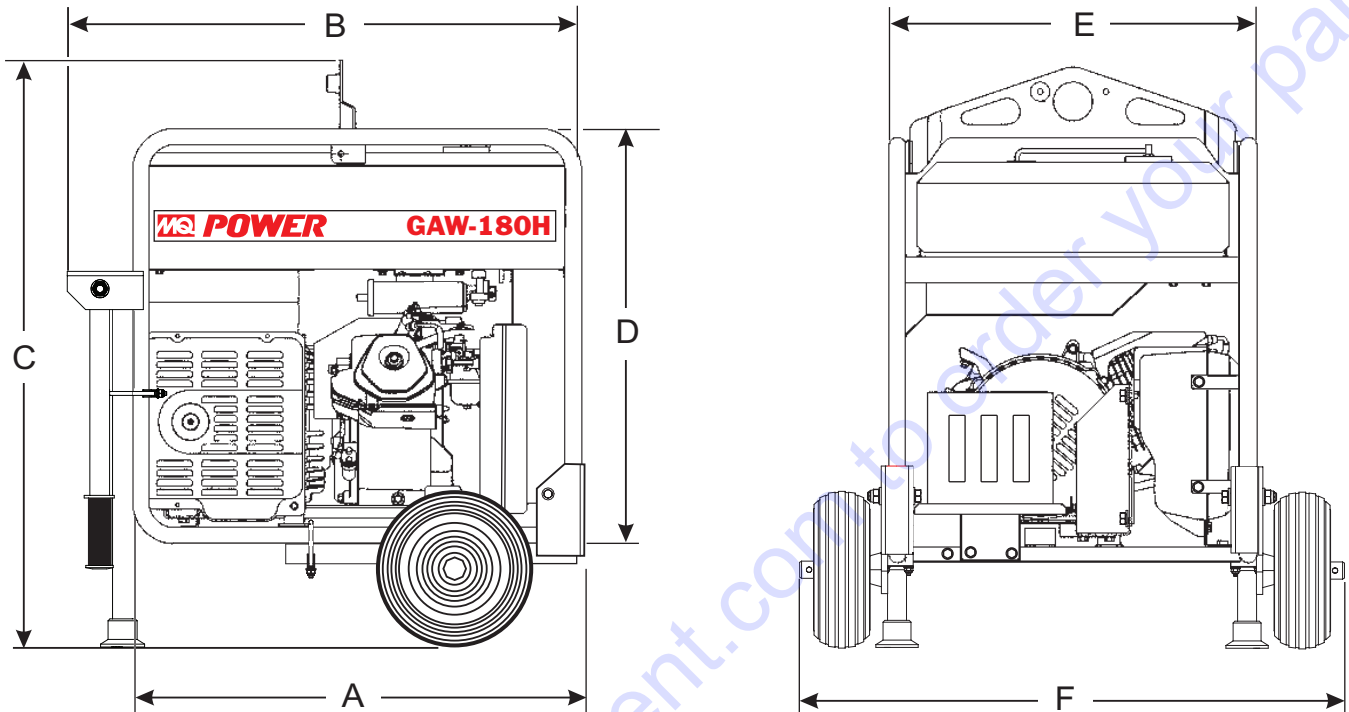

Figure 2. Dimensions

Table 3. Generator Dimensions

REFERENCE LETTER	DESCRIPTION	DIMENSIONS: IN. (MM)
A	LENGTH (FRAME)	27.55 (700)
B <sup>1</sup>	LENGTH (W/HANDLE)	30.55 (776)
C	HEIGHT (FRAME ONLY)	23.62 (600) HE 25.60 (650) HE1/HEA
D	HEIGHT (LIFTING BALE)	27.95 (710) HE 29.92 (760) HE1/HEA
E <sup>1</sup>	HEIGHT (FRAME/WHEELS)	28.62 (725) HE 30.60 (777) HE1/HEA
F	WIDTH (FRAME)	22.0 (560)
G <sup>1</sup>	WIDTH (WHEELS)	31.5 (800)

<sup>1</sup>Approximate value.



## CONNECTING THE GROUND

The ground point on the welder-generator should always be used to connect the generator to a suitable ground. The ground cable should be #8 size wire (aluminum) minimum. If copper wire is used, #10 size wire minimum should be used

At the generator, connect the terminal of the ground cable between the lock washer and the bolt (Figure 3) and tighten the bolt fully. Connect the other end of the ground cable to a suitable earth ground (ground rod).

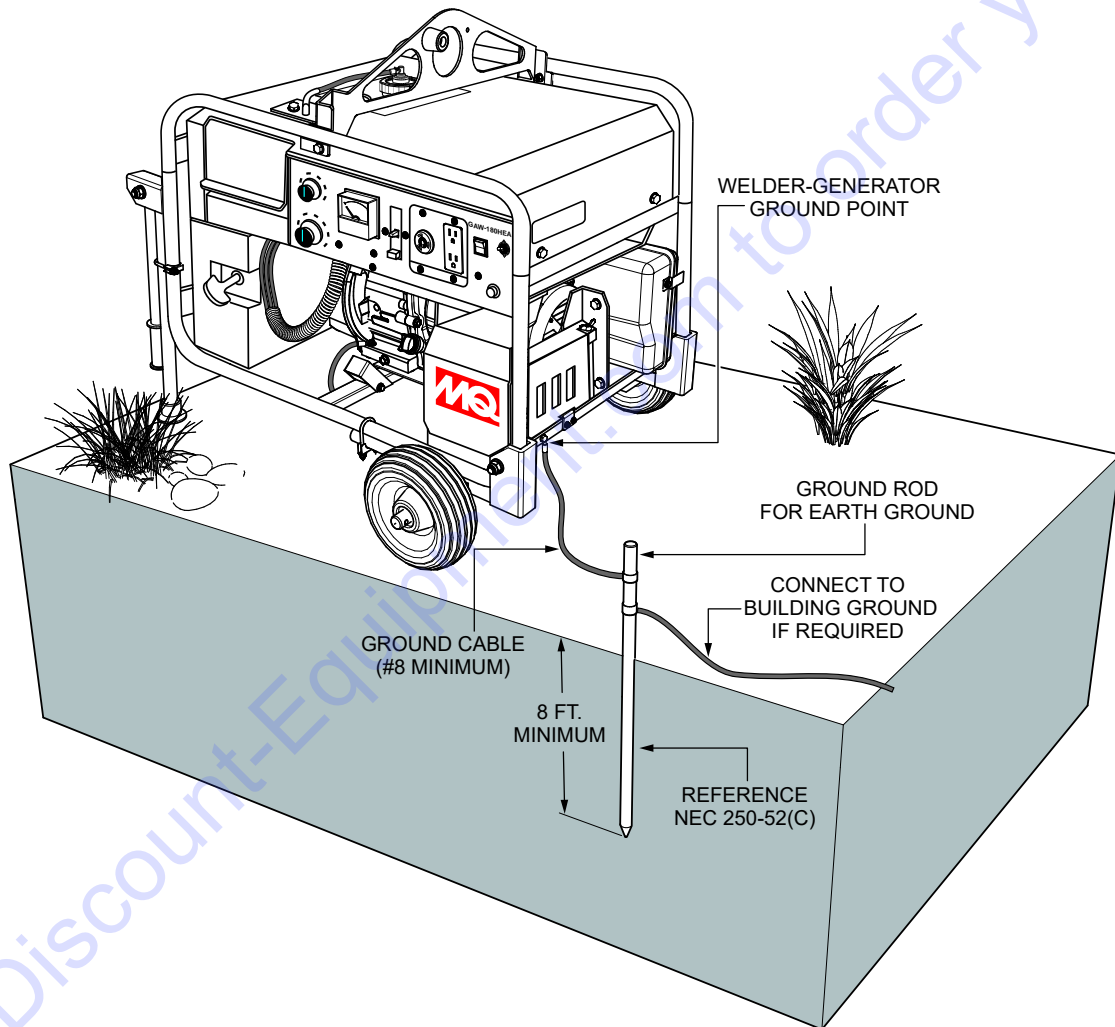

Figure 3. Welder-Generator Grounding

## OUTDOOR INSTALLATION

If possible install the generator in a area that is free of debris, bystanders, and overhead obstructions. Make sure the generator is on secure level ground so that it cannot slide or shift around.

The installation site must be relatively free from moisture and dust. All electrical equipment should be protected from excessive moisture. Failure to do will result in deterioration of the insulation and will result in short circuits and grounding.

Foreign materials such as dust, sand, lint and abrasive materials have a tendency to cause excessive wear to engine and alternator parts.

### WARNING



Pay close attention to ventilation when operating the generator inside tunnels and caves. The engine exhaust contains noxious elements. Engine exhaust must be routed to a ventilated area

## INDOOR INSTALLATION

Exhaust gases from gas engines are extremely poisonous. Whenever an engine is installed indoors the exhaust fumes must be vented to the outside. The engine should be installed at least two feet from any outside wall. Using an exhaust pipe which is too long or too small can cause excessive back pressure which will cause the engine to heat excessively and possibly burn the valves.

## PLACEMENT

The generator should always be placed on a flat level surface when it is running. **DO NOT** place the generator on slopes, the possibility exists that the generator could slide.

### DANGER



Electric shock can occur when vibrators are used. Pay close attention to handling when operating vibrators and always use rubber boots and gloves to insulate the body from a short circuit.

## GENERATOR GROUNDING

To guard against electrical shock and possible damage to the equipment, it is important to provide a good **EARTH** ground.

Article 250 (Grounding) of the National Electrical Code (NEC) provides guide lines for proper grounding and specifies that the cable ground shall be connected to the grounding system of the building as close to the point of cable entry as practical.

NEC articles 250-64(b) and 250-66 set the following grounding requirements:

1. Use one of the following wire types to connect the generator to earth ground.
  - a. Copper - 10 AWG (5.3 mm<sup>2</sup>) or larger.
  - b. Aluminum - 8 AWG (8.4 mm<sup>2</sup>) or larger.
2. When grounding the generator (Figure 3) connect the ground cable between the lock washer and the nut on the generator and tighten the nut fully. Connect the other end of the ground cable to earth ground.
3. NEC article 250-52(c) specifies that the earth ground rod should be buried a minimum of 8 ft. into the ground.

### NOTICE

When connecting the generator to any buildings electrical system **ALWAYS** consult with a licensed electrician.

### DANGER

Before connecting this generator to any building's electrical system, a licensed electrician must install an isolation (transfer) switch.

Serious injury or death may result without this transfer switch.

## GAW180HE/HEA FAMILARIZATION

Your welder-generator has been thoroughly inspected and accepted prior to shipment from the factory. However, be sure to check for damaged parts or components, or loose nuts and bolts, which could have become dislodged in transit.

This welder-generator has been designed as a portable lightweight power source for 60 Hz (single-phase) vibrators, lighting facilities, power tools, submersible pumps and other industrial and construction machinery.

The welder-generator is powered by a Honda GX340 air-cooled gasoline engine. The alternator, a brushless revolving-field type, is permanently aligned to the engine through rigid coupling.

The welder-generator is mounted on rubber vibration isolators that have a steel base backplate which is attached to the protective steel pipe carrying frame. The protective carrying frame is made of steel tubing and fully wraps around the generator to protect against damage.

These portable generators are supplied with a electrical control panel. The control panel includes items as listed below.

## CONTROL PANEL

- GFCI, Duplex Receptacle, NEMA 5-20R (120V, 20 Amp)
- Twist-Lock Receptacle, NEMA L5-30R (125V, 20 Amp)
- Main Circuit Breaker, 2-pole, 25 Amp
- Idle Control Switch
- Operation Switch
- Start Switch
- Hourmeter
- AC Voltmeter
- Current Regulator
- ARC Force Regulator
- DC Welding Output Terminal Lugs
- Canister

## ■ Ground Terminal

This unit is equipped with protection shutdown devices to protect the welder-generator in the event of an equipment malfunction. Reference Table 4 for a basic understanding of the protection devices and their effect on the welder-generator when activated.

If a malfunction has been detected by a protection device, simply shutdown the welder-generator and correct the problem before restarting the unit.

Table 4. Protection Shutdown Devices

Protection Device	Engine Shutdown	AC Circuit Breaker GFCI Trip	Control Unit Output Stop
Low Oil Level	YES	NO	NO
AC Power Overcurrent	NO	YES	YES
Electrical Ground Fault	NO	YES	NO
Control Unit (AC) High Temp. <sup>1</sup>	NO	NO	YES
Control Unit (AC) High Temp. <sup>2</sup>	NO	NO	YES

<sup>1</sup>Stop engine for at least 20 seconds before restarting.

<sup>2</sup>Output will resume as temperature falls to normal operating level.

# WELDING POLARITY AND DUTY CYCLE

## WELDING POLARITY

Polarity indicates the direction of the current flow in that circuit. Since DC current moves in only one direction, polarity is important because the flow of current must be changed depending on the application.

By changing the polarity, the greatest amount of heat can be concentrated where it is most needed. With straight polarity (electrode negative) more heat is directed to the workplace. When using reverse polarity (electrode positive), more of the heat generated is directed to the electrode. Reference Figure 4 below.

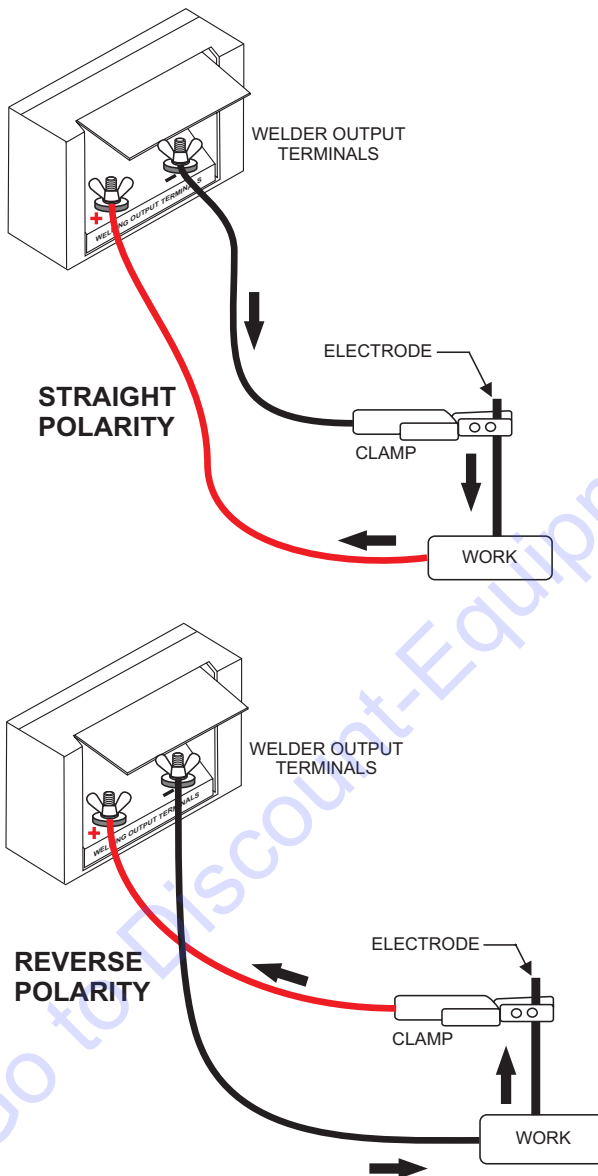

Figure 4. Welding Polarities

## DUTY CYCLE

### NOTICE

The **American Welding Society** sets all regulations and procedures for the welding industry. All welders are subject to the same regulations.

**Duty cycle** is based on a 10-minute welding period. Exceeding the duty cycle will have an affect on the welding process. The amperage will start dropping off and the welding process will not have the proper amperage required to proceed. If the duty cycle is exceeded, damage can occur to the welding machine.

The 10-minute duty cycle period means 100% welding. If the duty cycle is 60%, then you can only weld for six minutes and the machine must cool down for four minutes (Reference Table 5 below).

Table 5. 10-Minute Duty Cycle

Duty Cycle %	Welding ON Time (Min)	Cool Down Time (Min.)	Welding Current (Amps)
100	Continuous	N/A	120 or Less
85	8.5	1.5	130
70	7	3	140
60	6	4	150
55	5.5	4.5	160
50 <sup>1</sup>	5	5	170
40	4	6	180

<sup>1</sup>The GAW180HE/HEA welders have a 50% duty cycle @ 170 amps.

## DEFINITIONS OF WELDING TERMS

1. **Weld** – The unification of metallic parts by heating and allowing the metals to flow together or by hammering or compressing with or without previous heating.
2. **Straight Polarity** – A term for direct current electrode negative.
3. **Reverse Polarity** – A term for direct current electrode positive.
4. **Manual Welding** – A welding operation performed and controlled completely by hand.
5. **AC or Alternating Current** – AC is the kind of electricity, which reverses its direction periodically. For 60 cycle current, the current goes in one direction and then in the other direction 60 times in the same second, so that the current changes its direction 120 times in one second.
6. **DC or Direct Current** – DC is the kind of electricity, which only flows in one direction. The flow of electricity is from the power source to the application. In welding, an arc welding process wherein the power supply is at the arc is direct current.
7. **ARC Force** – An adjustment that allows the operator to fine tune the arc characteristics according to job requirements.
8. **ARC Length** – The distance from the end of the electrode to the point where the arc makes contact with the work surface.
9. **ARC Voltage** – The voltage across the welding arc.
10. **ARC Blow** – The deflection of an electric arc from its normal path because of magnetic forces.
11. **Base Metal (Material)** – The metal (material) to be welded, brazed, soldered, or cut.
12. **E-Mode** – The Improves fuel efficiency by allowing the operator to weld with engine at idle speed at up to 160 amps. Reduces operating costs and noise levels.
13. **Covered Electrode** – A composite fill metal electrode consisting of a core of a bare electrode or metal-cored electrode to which a covering sufficient to provide a slag layer on the weld metal has been applied.

The covering may contain materials providing such functions as shielding from the atmosphere, deoxidization, and arc stabilization and can serve as a source of metallic additions to the weld.
14. **Fillet Weld** – A weld of triangular cross section joining two surfaces approximately at right angles to each other in a lap joint, T-joint or corner joint.
15. **Tack Weld** – A weld made to hold parts of a weldment for proper alignment until the final welds are made.
16. **Shade Number** – This number pertains to the lightness or darkness of the lens in the welding helmet. Lens number range from 2 to 14 where 2 would be the lightest lens and 14 would be the darkest lens.
17. **CC or Constant Current** – In this mode the amperage or current stays constant, but the direct current voltage will change depending on the arc length. This mode is applied to SMAW, FCAW and GTAW processes.
18. **CV or Constant Voltage** – In this mode the direct current voltage stays constant, but direct current amperage will change slightly. This mode is applied to GMAW, FCAW and GTAW.
19. **Parallel Connection** – Simply connect the positive terminals together, then connect the negative terminals together. Make sure that the machines are located as close together as possible.

Welding cables should be sized appropriately to handle the additional amperage. Rheostats must be set at the same amperage or as close as possible. (Note: Unlike competitive models, no parallel box is needed with Multiquip Power machines.)

## WELDING PROCESSES

- SMAW – Shielded-Metal Arc Welding
- FCAW – Flux-Cored Arc Welding
- GMAW – Gas-Metal Arc Welding
- GTAW – Gas-Tungsten Arc Welding
- ACAC – Air Carbon Arc Cutting

# COMPONENTS GENERATOR

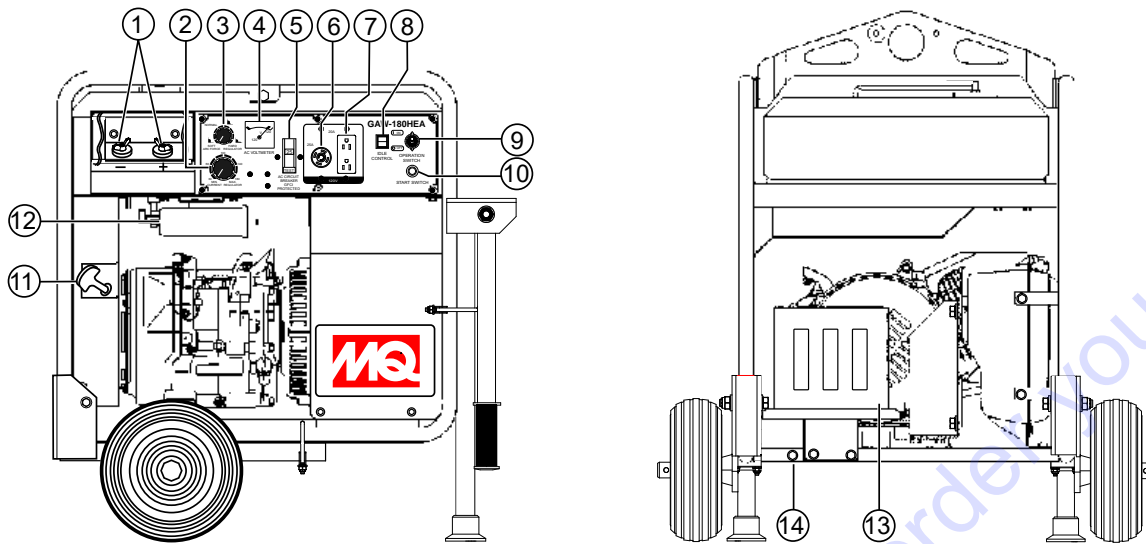

Figure 5. Welder-Generator

1. **DC Welding Output Terminals** – Connect DC welding cables to these terminals. Note the polarity marked on the welder-generator. Select the appropriate polarities according to the application as specified in Table 8.
2. **Current Regulator Adjustment Control** – Place this knob in the desired setting when welding is required. Current range is from 30 to 180 amps. t
3. **ARC Force Regulator Adjustment Control** – An adjustment that allows the operator to fine tune the arc characteristics according to job requirements. This control allows the user to adjust the arc from a soft smooth arc to a more aggressive digging arc.
4. **AC-Voltmeter** – This voltmeter indicates (with a mark) the rated 60 Hz (single-phase) output voltage. In addition the voltmeter can also be used as a diagnostic tool. If the voltmeter indicator (needle) is below the rated voltage, engine problems may exist (low/high RPM's). To prevent damage to the generator or power tools turn the generator **OFF** and consult Discount-equipment.
5. **Main Breaker** – This 2-pole, 25 amp circuit breaker protects the welder-generator from short circuiting or overloading. When starting the generator always have the circuit breaker placed in the "OFF" position.
6. **120V Output Receptacle** – NEMA L5-30R twist-lock receptacle will provide 120V, 25 amps, 60 Hz.
7. **GFCI Duplex Receptacles** – NEMA 5-20R, GFCI receptacle will provide 120V@ 20 amps.
8. **Idle Control Switch** – The welder-generator is provided with an automatic idle control device for noise suppression and reduced fuel consumption.  
The automatic idle control automatically engages under a no-load condition. With the automatic idle control switched "ON", the engine revolutions will automatically drop to about 2600 rpm (low-speed operation) within 3 seconds after the load stops. When the operation is resumed, the engine speed is automatically increased to about 3600 rpm (high-speed operation) as soon as the load is connected.
9. **Operation Switch** – Place switch in the "ON" position (up) for normal operation. To turn-off the welder-generator, place the operation switch in the "OFF" position (down).
10. **Start Switch** – Press this pushbutton switch to start the welder-generator.
11. **Recoil Starter (pull rope)** – Manual-starting method. Pull the starter grip until resistance is felt, then pull briskly and smoothly.
12. **Charcoal Canister** – A container filled with activated charcoal that traps gasoline vapors emitted by the fuel system. Installed on GAWHE1/HEA only.
13. **Battery** – This unit is equipped with a 12 VDC battery. Replace with only recommended type battery.
14. **Ground** – This ground connection point should be connect to a good earth ground (ground rod).

## COMPONENTS GENERATOR (CONTINUED)

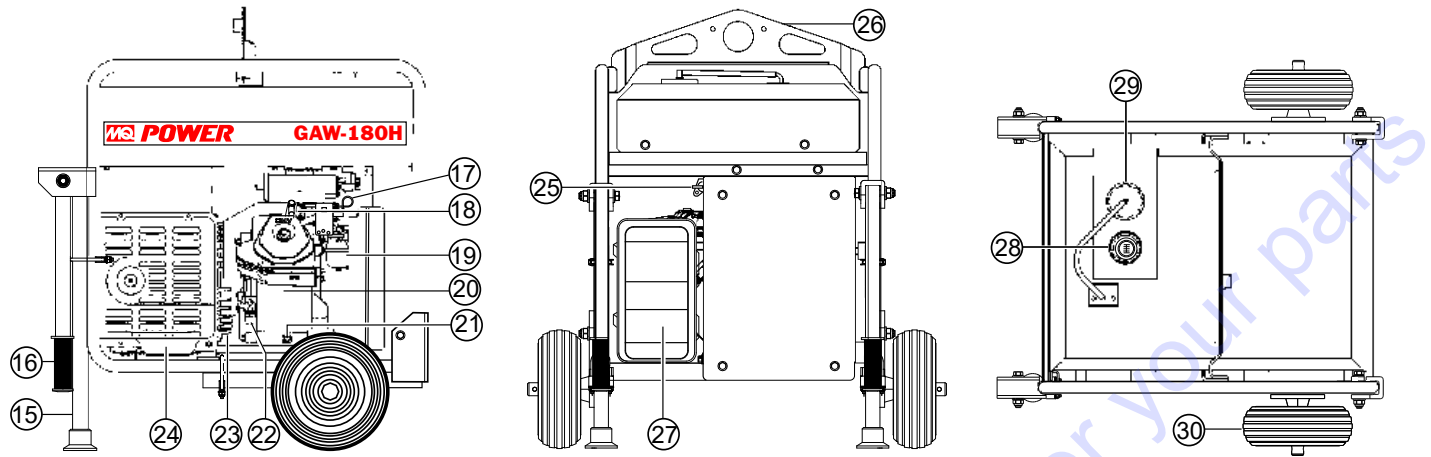

Figure 6. Welder-Generator Components (Continued)

15. **Support Stand (Option)** – Supports the welder-generator, part of the UWKB Wheel Kit Assembly.
16. **Transport Handles (Option)** – Lift up on each handle when transporting of the welder-generator is required. Part of the UWKB Wheel Kit Assembly.
17. **Choke Lever** – Used for starting the engine. Close the choke lever when starting a cold engine or in cold weather conditions. The choke enriches the fuel mixture. Open the choke lever if starting a warm engine or in warm weather conditions.
18. **Spark Plug** – Provides spark to the ignition system. Set spark plug gap to 0.6 - 0.7 mm (0.028 - 0.031 inch). Clean spark plug once a week.
19. **Carburetor Cup** – Inspect the fuel cup weekly for water and dirt. Clean as referenced in the maintenance section of this manual.
20. **Engine** – This welder generator uses a HONDA GX340 air-cooled, 4-stroke, single cylinder, overhead camshaft gasoline engine. Engine uses unleaded gasoline. For more detailed specifications reference Table 2.
21. **Engine Oil Drain Plug** – Remove this drain plug when draining of the oil from the engine crankcase is required. Fill with recommended type oil as listed in See Table 7.
22. **Engine Oil Filler Cap** – Remove this cap/dipstick when the adding of engine oil is required. See Table 7 for recommended type engine oil.
23. **Generator Housing** – Contains the rotor, rectifier field coil assembly, armature, bearings and other components that make up generator assembly.
24. **Muffler/Heat Shield** – Used to reduce noise and emissions. **NEVER** touch this heat shield when the generator/welder is in use. Always allow time for engine to cool before servicing.
25. **Fuel Cock Lever** – Turn this lever downward (**ON**) to start the flow of fuel into the carburetor. Turn upward to stop (**OFF**) the flow of fuel.
26. **Lifting Bail Eye** – Attach a rope or chain to this lifting eye when lifting of the welder-generator is required. Never stand underneath the welder-generator while it is being lifted. Place lifting eye in down position when not in use.
27. **Air Cleaner** – Prevents dirt and other debris from entering the fuel system. Remove wing-nut on top of air filter cannister to gain access to filter element. **NEVER** run the engine without an air cleaner.
28. **Fuel Gauge** – This gauge is located on top of the fuel tank. Read this gauge to determine when fuel is low.
29. **Fuel Tank Cap** – Remove this cap to add unleaded gasoline to the fuel tank. Replenish with clean unleaded gasoline. Make sure cap is tightened securely. **DO NOT** over fill. Fuel tank capacity is 3.7 gallons (14 liters).
30. **Foam-Filled Tires** – Provided for ease of transport. Replace with only recommended tires.

## GENERAL INSPECTION PRIOR TO OPERATION

### Ground Power Tools

When using power tools or electrical equipment requiring AC power from the generator, make sure power tool cord has a ground pin or is double insulated as shown in Figure 7.

**NOTICE**

Double-insulated power tools and small appliances have specially insulated housings that eliminate the need for a ground pin. These types of double-insulated power cords are designed so that no part of the device will be electrically live even if the internal insulation fails.

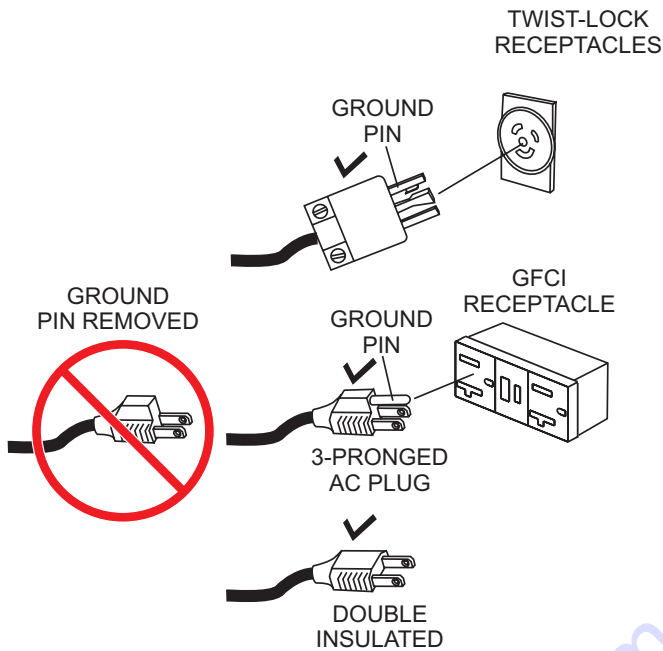

Figure 7. Ground Pin

### Extension Cable

When electric power is to be provided to various tools or loads at some distance from the generator, extension cords are normally used. Cables should be sized to allow for distance in length and amperage so that the voltage drop between the generator and point of use (load) is held to a minimum. Use the cable selection chart (Table 6) as a guide for selecting proper cable size.

**DANGER**

**NEVER** use power tools or equipment that do not have a ground capability, the possibility exists of electrocution, electrical shock or burn, which can cause severe bodily harm or even **DEATH!**

Table 6. Cable Selection (60 Hz, Single Phase Operation)

Current In Amperes	Load In Watts		Maximum Allowable Cable Length			
	120 Volts	240 Volts	#10 Wire	#12 Wire	#14 Wire	#16 Wire
2.5	300	600	1000 ft.	600 ft.	375 ft.	250 ft.
5	600	1200	500 ft.	300 ft.	200 ft.	125 ft.
7.5	900	1800	350 ft.	200 ft.	125 ft.	100 ft.
10	1200	2400	250 ft.	150 ft.	100 ft.	
15	1800	3600	150 ft.	100 ft.	65 ft.	
20	2400	4800	125 ft.	75 ft.	50 ft.	

**CAUTION:** Equipment damage can result from low voltage.



## BEFORE STARTING

### NOTICE

**ALWAYS** place the AC circuit breaker in the **OFF** position prior to starting the engine.

1. Read safety instructions at the beginning of manual.
2. Clean the welder-generator, removing dirt and dust, particularly the engine cooling air inlet, carburetor and air cleaner.
3. Check the air filter for dirt and dust. If air filter is dirty, replace air filter with a new one as required.
4. Check carburetor for external dirt and dust. Clean with dry compressed air.
5. Check fastening nuts and bolts for tightness.

## Engine Oil Check

1. To check the engine oil level, place the welder-generator on secure level ground with the engine stopped.
2. Remove the filler dipstick from the engine oil filler hole (Figure 8) and wipe clean.

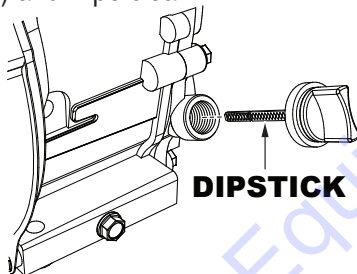

Figure 8. Engine Oil Dipstick Removal

3. Insert and remove the dipstick without screwing it into the filler neck. Check the oil level shown on the dipstick.
4. If the oil level is low (Figure 9), fill to the edge of the oil filler hole with the recommended oil type (Table 7). Maximum oil capacity is 1.16 quarts (1.1 liters).

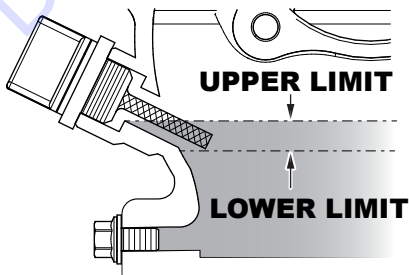

Figure 9. Engine Oil Dipstick(Oil Level)

Table 7. Oil Type

Season	Temperature	Oil Type
Summer	25°C or Higher	SAE 10W-30
Spring/Fall	25°C~10°C	SAE 10W-30/20
Winter	0°C or Lower	SAE 10W-10

## Fuel Check

1. Close the fuel cock before filling the fuel tank.
2. Remove the fuel cap located on top of fuel tank.
3. Read the fuel gauge located on top of the fuel tank (Figure 10) to determine if the fuel level is low. If fuel is low, replenish with clean unleaded fuel.

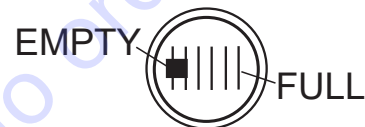

Figure 10. Fuel Gauge

4. When refueling, be sure to use a strainer for filtration. **DO NOT** top-off fuel. **DO NOT** fill the tank beyond capacity. Wipe up any spilled fuel **immediately!**

## BATTERY SETUP

### CAUTION

Use all safety precautions specified by the battery manufacturer when working with the battery. See Safety Information section of this manual for more details on battery safety.

1. Place the battery into the battery cradle and secured with mounting hardware.
2. **ALWAYS** be sure the battery cables are properly connected to the battery terminals (Figure 11). The **red** cable is connected to the positive terminal of the battery, and the **black** cable is connected to the negative terminal of the battery.

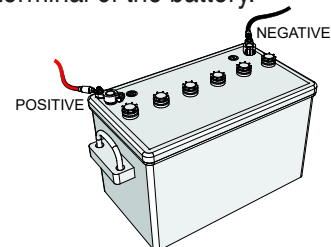
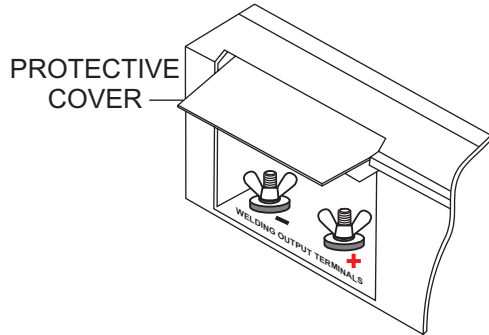

Figure 11. Battery Connections

## WELDING CABLE AND POLARITIES

1. Lift the output terminal protective cover (Figure 12) on the welder-generator to gain access to the welding output terminals.



**Figure 12. Protective Cover**

2. Next, remove the wing nuts and flat washers that are attached to the output terminals.
3. Place welder cables onto output terminals (post). Select appropriate polarity depending on application. Reference Table 8 and Table 9.

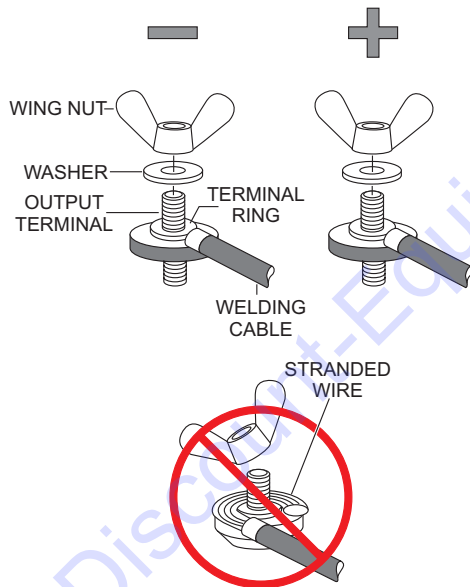

**Figure 13. Welding Cable Attachment**

### NOTICE

**ALWAYS** attach a terminal ring on the end of the welding cables. **NEVER** attach stranded or exposed wires to the output terminals. This condition could cause arcing which could start a fire.

4. Reinstall wing nuts and washers back onto output terminals. Tighten wing nuts securely to prevent arcing.

### NOTICE

**NEVER** allow the terminal ends of the welding cables to come in contact with each other or the frame of the welder-generator. The possibility exists of creating sparks which could ignite a fire causing damage to the equipment and bodily harm.

**Table 8. Polarities and Applications**

Polarity	Welding Method	Typical Applications
Straight Polarity	(+)...grounding (base metal)	Arc welding for steel material of general structures, and for thick plates
	(-)...welding holder	Arc welding for copper alloy
Reverse Polarity	(+)...welding holder	Build-up welding Air gouging
	(-)...grounding (base metal)	Arc welding of thin plates Arc welding of stainless steel

## WELDING CABLE SELECTION

The welding cable should be larger in size as it becomes longer or its current becomes higher. Prepare a cable with suitable size by referring to the table below.

Calculations for Table 9 are based on a voltage drop of 4 volts maximum.

**Table 9. Total Cable (Copper) in Weld Circuit Not Exceeding**

Weld Current (A)	Length (ft/m)	50	100	150	200	250	300
		(15)	(30)	(46)	(61)	(76)	(91)
50		#5	#5	#5	#5	#5	#4
100		#5	#5	#4	#3	#2	#1
150		#5	#4	#2	#1	#1/0	#2/0
180		#5	#3	#1	#1/0	#2/0	#3/0

Reference Table 10 for applicable electrode size.

**Table 10. Applicable Electrode Size**

Welding Current (A)	30~180
Applicable Electrode	3/32"~5/32"

## OPERATION

This section is intended to assist the operator with the initial start-up of the portable welder-generator. It is extremely important that this section be read carefully before attempting to use the generator in the field.

### Before Starting the Engine

1. Be sure to disconnect all electrical loads from the welder-generator prior to starting the engine.
2. **NEVER** start the engine with the AC circuit breaker in the **ON** position. Always place AC circuit breaker (Figure 14) in the **OFF** position before starting.

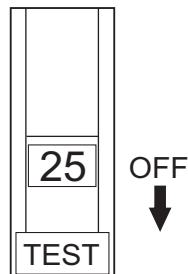

Figure 14. AC Circuit Breaker (OFF)

### Starting the Engine (Electric Start)

1. Place the engine fuel valve lever (Figure 15) in the **ON** position.

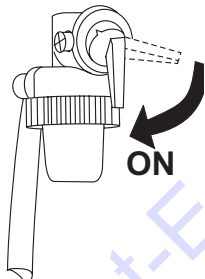

Figure 15. Engine Fuel Valve Lever (ON)

2. Place the choke lever (Figure 16) in the **CLOSED** position if starting a cold engine.

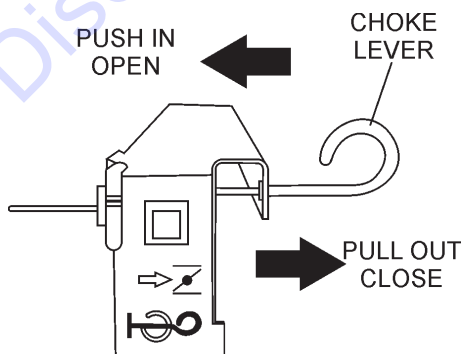

Figure 16. Choke Lever

3. Place the choke lever (Figure 16) in the **OPEN** position if starting a warm engine or the temperature is warm.
4. Place the generator's operation switch (Figure 17) in the **ON** position.

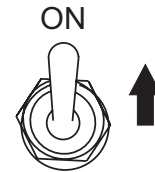

Figure 17. Operation Switch (ON)

5. Next, press the generator's pushbutton start switch (Figure 18) and listen for the engine to start. If starting the welder-generator using the recoil start method, proceed to step 11.



Figure 18. Start Switch

6. If the engine has started, slowly return the choke lever (Figure 16) to the **OPEN** position. If the engine has not started repeat steps 1 through 6.
7. Before the generator is placed into operation, run the engine for 3-5 minutes. Check for abnormal smells, fuel leaks, and noises that would associate with loose components.
8. Place idle control switch (Figure 19) in the **OFF** position. This will allow the engine speed to run at about 3600 RPM's (**high speed**).

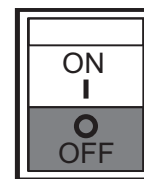

Figure 19. Idle Control Switch (OFF)

## OPERATION

### NOTICE

Placing the idle control switch in the **OFF** position (Figure 19) allows the engine to operate at a maximum speed of about 3600 RPM's.

When the idle control switch is placed in the up position **ON** position (Figure 20), the generator will run at idle speed (2600 RPM's) until a load is applied, at that time the engine speed will increase to 3600 RPM's as long as a load is being applied.

When the load is not in use, the engine speed will drop back to the idle mode after about 3 seconds.

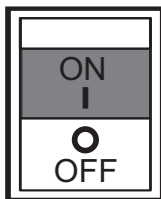

Figure 20. Idle Control Switch (ON)

9. Place AC circuit breaker (Figure 21) in the **ON** position .

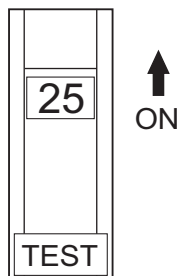

Figure 21. AC Circuit Breaker (ON)

10. Read voltmeter on front panel of generator (Figure 22) and verify that 120 VAC is displayed. Using an external voltmeter as shown in Figure 22, verify that 120 VAC is present at the 120V twist-lock and GFCI duplex receptacles.

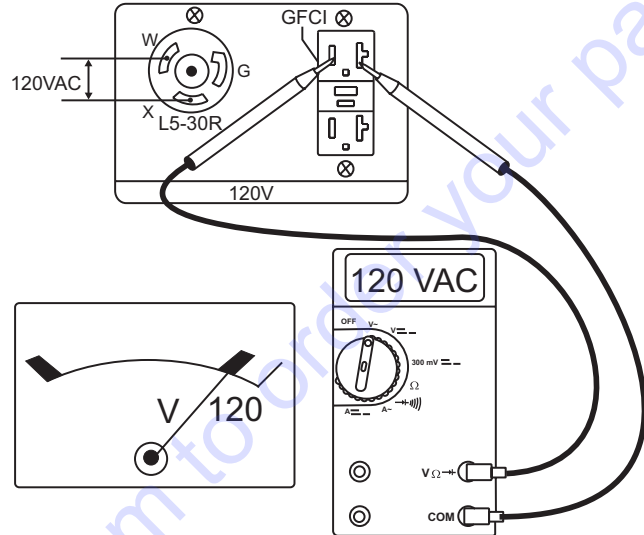

Figure 22. 120V Twist-Lock/GFCI Receptacles

11. If starting your welder-generator by the **recoil start method** (no battery), grasp the starter grip (Figure 23) and slowly pull it out. The resistance becomes the hardest at a certain position, corresponding to the compression point. Pull the starter grip briskly and smoothly for starting.

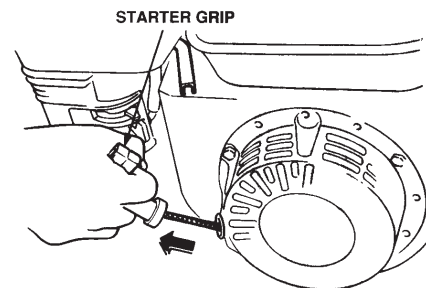

Figure 23. Starter Grip

### NOTICE

**DO NOT** pull the starter rope all the way to the end.

**DO NOT** release the starter rope after pulling. Allow it to rewind as soon as possible..

12. Continue using the welder-generator referencing steps 6 through 10.

## WELDING OPERATION

Adjust the arc force and current regulator control knobs (Figure 24) to their respective positions depending on the characteristics of the job requirements.

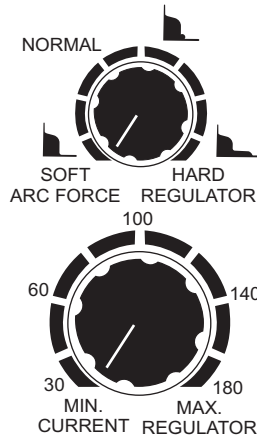

**Figure 24. Arc Force And Current Regulator Control Knob**

### NOTICE

When **high quality welding** is required **DO NOT** use convenience receptacles simultaneously.

Both welder-generator models are equipped with a single phase AC power source in addition to the DC welding power source.

The AC power source and DC welding power source can be used simultaneously. Reference Table 11 for the simultaneous use of AC and DC power.

### NOTICE

**DO NOT** allow welder-generator overloading when AC and DC power are used simultaneously.

**Table 11. AC Power Capacity Allowable For Simultaneous Use**

Electrode Size (Amps)	AC Power Capacity
(0)	3.0 kW
3/32" (50A)	2.0 kW
1/8" (80A)	1.4 kW
1/8" (120A)	1.0 kW
5/32" (150A)	0.5 kW

## Stopping the Engine (Normal Shutdown)

1. Place AC circuit breaker (Figure 25) in the **OFF** position

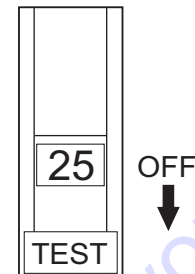

**Figure 25. AC Circuit Breaker (OFF)**

2. Place idle control switch (Figure 26) in the **OFF** position

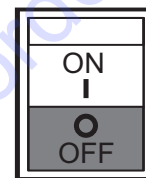

**Figure 26. Idle Control Switch (OFF)**

3. Let engine run at idle with no load for 2-3 minutes.
4. To shut-down the engine, place the generator's operation switch (Figure 27) in the **OFF** position.



**Figure 27. Operation Switch (OFF)**

5. Place engine fuel valve lever (Figure 28) in the **OFF** position.

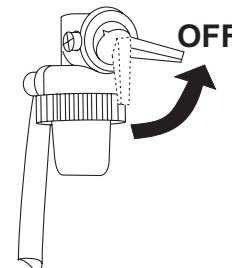

**Figure 28. Engine Fuel Valve Lever (OFF)**

6. Remove all loads and cables from the welder-generator.

## Emergency Shutdown

1. Place operation switch (Figure 27) in the **OFF** position.

## PREPARATION FOR LONG TERM STORAGE

---

### Generator Storage

For storage of the generating set for over 30 days, the following is required:

- Drain the fuel tank completely, or add STA-BIL to the fuel.
- Run the engine until the gasoline in the carburetor is completely consumed.
- Completely drain the oil from the crankcase and refill with fresh oil.
- Remove the spark plug, pour 2 or 3 cc of SAE 30 oil into the cylinder and crank slowly to distribute the oil.
- Slowly rotate the engine a few times with the starter rope and install a new plug.
- Pull out the starter rope slowly and stop at the compression point.
- Clean all external parts of the generating set with a cloth.
- Cover the generating set and store in a clean, dry place.

Go to Discount-Equipment.com to order your parts

# MAINTENANCE

Use Table 12 as a general maintenance guideline when servicing your engine. For more detail engine maintenance information, refer to the engine owner's manual supplied with your engine.

Table 12. Engine Maintenance Schedule							
DESCRIPTION (3)	OPERATION	BEFORE	FIRST MONTH OR 10 HRS.	EVERY 3 MONTHS OR 25 HRS.	EVERY 6 MONTHS OR 50 HRS.	EVERY YEAR OR 100 HRS.	EVERY 2 YEARS OR 200 HRS.
Engine Oil	CHECK	X					
	CHANGE		X		X	X	X
Air Cleaner	CHECK	X	X				
	CHANGE			X (1)			
Charcoal Canister (4)	REPLACE						
All Nuts & Bolts	RETIGHTEN IF NECESSARY	X					
Spark Plug	CHANGE				X		
	REPLACE						X
Cooling Fins	CHECK				X		
Spark Arrester	CLEAN					X	
Fuel Tank	CLEAN					X	
Fuel Strainer	CHECK				X	X	
Idle Speed	CHECK-ADJUST					X (2)	
Valve Clearance	CHECK-ADJUST			X		X	X (2)
Fuel lines	CHECK						Every 2 years, replace if necessary (2)

(1) Service more frequently when used in **DUSTY** areas.

(2) These items should be serviced by your service dealer, unless you have the proper tools and are mechanically proficient. Refer to the HONDA Shop Manual for service procedures.

(3) For commercial use, log hours of operation to determine proper maintenance intervals.

(4) Charcoal canister is maintenance free (non-servicable). Replace only if damaged.

## MAINTENANCE

Perform the scheduled maintenance procedures as defined by Table 12 on the previous page.

### Daily

Thoroughly remove dirt and oil from the engine and control area. Clean or replace the air cleaner elements as necessary. Check and retighten all fasteners as necessary.

### Wiring

Inspect the entire generator for bad or worn electrical wiring or connections. If any wiring or connections are exposed (insulation missing) replace wiring immediately.

### Piping and Hose Connection

Inspect all piping, oil hose, and fuel hose connections for wear and tightness. Tighten all hose clamps and check fuel or leaks. If any hose (fuel or oil) lines are defective replace them immediately.

### Fuel Strainer

1. Thoroughly clean the area around the fuel cap.
2. Remove the fuel cap from the fuel tank.
3. Next, remove, inspect and clean the fuel strainer (Figure 29) with solvent.

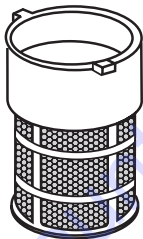

Figure 29. Fuel Strainer

### Spark Plug

1. Remove and clean the spark plug (Figure 30), then adjust the spark gap to 0.024~0.028 inch (0.6~0.7 mm). This unit has electronic ignition, which requires no adjustments.

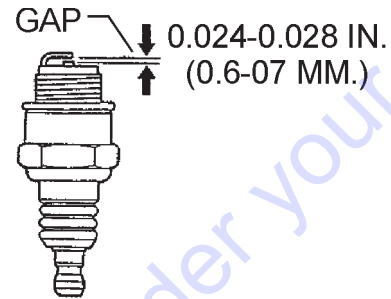

Figure 30. Spark Plug Gap

### ENGINE OIL

2. Drain the engine oil when the oil is warm as shown in (Figure 31).
3. Remove the oil drain bolt and sealing washer and allow the oil to drain into a suitable container.
4. Replace engine oil with recommended type oil as listed in (Table 7). For engine oil capacity, see (Table 2) (engine specifications). **DO NOT** overfill.
5. Install drain bolt with sealing washer and tighten securely.

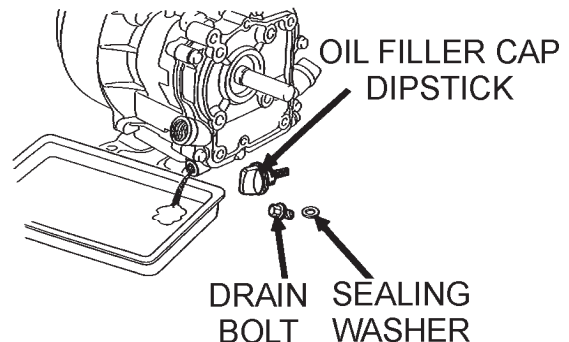

Figure 31. Draining Engine Oil

### **DANGER**



**DO NOT** use gasoline as a cleaning solvent, the possibility exists of fire or explosion which can cause damage to the equipment and severe bodily harm or even **DEATH!**



## ENGINE AIR CLEANER

1. Remove the air cleaner cover (Figure 32) and foam filter element as shown in .
2. Clean foam element in warm, soapy water or nonflammable solvent. Rinse and dry thoroughly. Dip the element in clean engine oil and completely squeeze out the excess oil from the element before installing.

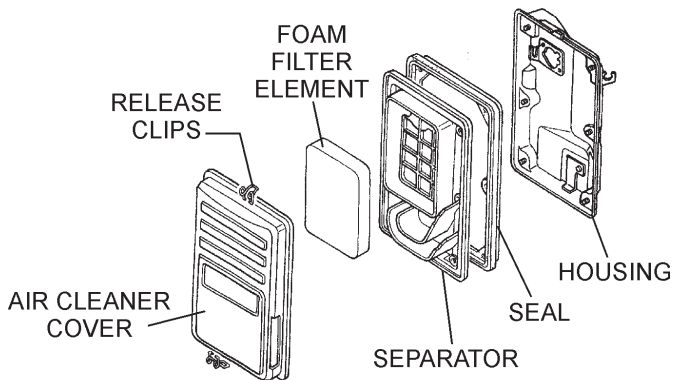

**Figure 32. Engine Air Cleaner**

3. Clean foam element (Figure 33) in warm, soapy water or non-flammable solvent. Rinse and dry thoroughly.
4. Next, dip the element in clean engine oil and completely squeeze out the excess oil from the element before installing.

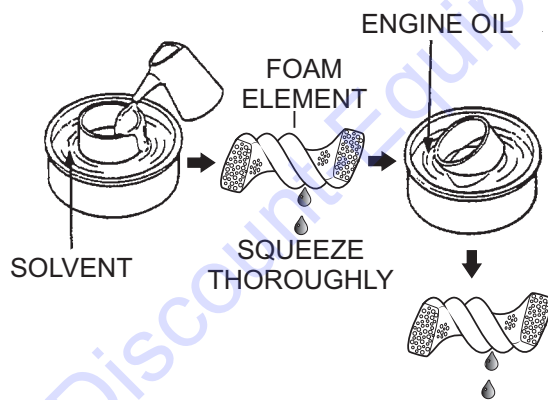
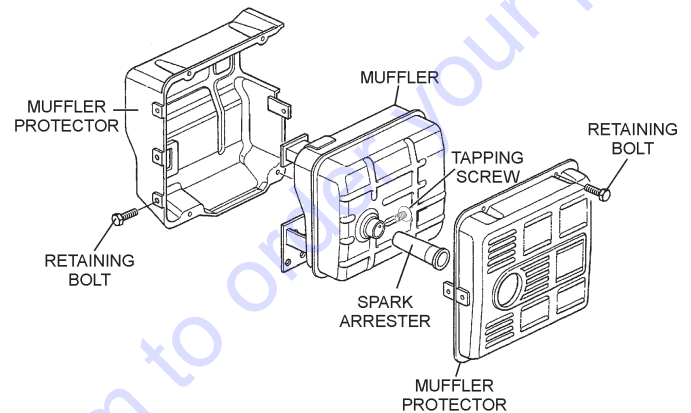

**Figure 33. Cleaning Foam Element**

## SPARK ARRESTER CLEANING

Clean the spark arrester every 6 months or 100 hours.

1. Remove the muffler protector retaining bolts (Figure 34), then remove muffler protector.
2. Next, remove tapping screw that secures spark arrester to muffler, then remove spark arrester.



**Figure 34. Spark Arrester Removal**

3. Carefully remove carbon deposits from the spark arrester screen (Figure 35) with a wire brush.

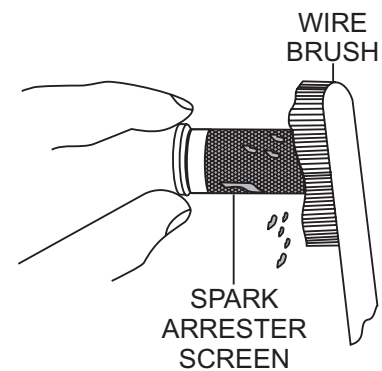

**Figure 35. Cleaning The Spark Arrester**

4. If the spark arrester is damaged and has breaks or holes, replace with a new one.
5. Reinstall the spark arrester and muffler protector in reverse order of disassembly.

## BATTERY

This unit is of negative ground. **DO NOT** connect in reverse. Always maintain battery fluid level between the specified marks. Battery life will be shortened, if the fluid levels are not properly maintained. Add only distilled water when replenishment is necessary.

Check to see whether the battery cables are loose. Poor contact may result in poor starting or malfunctions. Always keep the terminals firmly tightened. Coating the terminals with an approved battery terminal treatment compound will help prevent corrosion. Replace battery with only recommended type battery.

The battery is sufficiently charged if the specific gravity of the battery fluid is 1.28 (at 68° F). If the specific gravity should fall to 1.245 or lower, it indicates that the battery is dead and needs to be recharged or replaced.

Before charging the battery with an external electric source, be sure to disconnect the battery cables.

## BATTERY CABLE INSTALLATION

### NOTICE

Inadequate battery cable connections may cause poor starting of the generator, and create other malfunctions.

**ALWAYS** be sure the battery cables are properly connected to the battery terminals (Figure 36). The **red** cable is connected to the positive terminal of the battery, and the **black** cable is connected to the negative terminal of the battery.

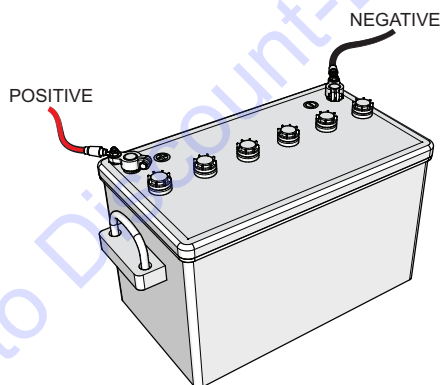

Figure 36. Battery Connections

### NOTICE

**ALWAYS** disconnect the negative terminal first and reconnect negative terminal last.

When connecting battery do the following:

1. **NEVER** use worn or damaged battery cables. Replace defective battery cables immediately.
2. Place a small amount of battery terminal treatment compound around both battery terminals. This will ensure a good connection and will help prevent corrosion around the battery terminals.

### NOTICE

If the battery cables are connected incorrectly, electrical damage to the generator will occur. Pay close attention to the polarity markings on the battery when connecting the battery cables.

## POLARITY

The polarity of the battery is extremely important. When an inverted circuit connection takes place, the circuit will be in short circuit instantaneously resulting in possible damage to the control box electronics and starter.

When connecting the battery cables to the battery terminals be sure to check the polarity.

## TESTING THE GFCI CIRCUIT BREAKER

1. Start the generator as outlined in the start up procedure in this manual.
2. Place idle control switch (Figure 37) in the **OFF** position. This will allow the engine speed to run at about 3600 RPM's (*high speed*).

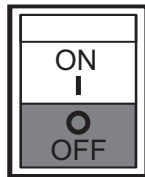

**Figure 37. Idle Control Switch ON (GFCI Test)**

3. Place the AC circuit breaker (Figure 38) in the **ON** position.

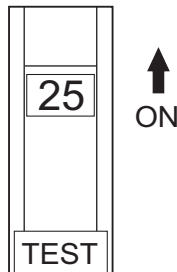

**Figure 38. AC Circuit Breaker ON (GFCI Test)**

4. Press the **test button** (Figure 39) on the AC circuit breaker and verify that the circuit breaker lever moves (*click*) from the **ON** position to the **center** trip position. This indicates that the GFCI breaker is working correctly and ground faults will be detected.

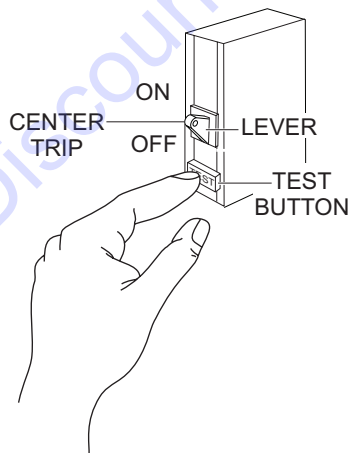

**Figure 39. GFCI Breaker (Test)**

5. Use an external voltmeter as shown in Figure 40, and verify that no voltage (zero) is present at the 120V twist-lock and GFCI duplex receptacles.

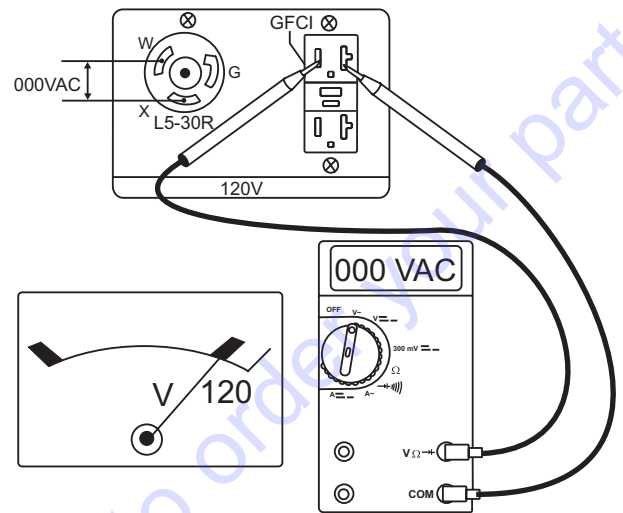

**Figure 40. 120V Twist-Lock/GFCI Receptacles (GFCI Test)**

### NOTICE

The AC voltmeter on the control panel will still indicate 120 VAC since it is not connected to the load side of the breaker.

6. Reset AC circuit breaker by placing lever to the **OFF** position then to the **ON** position.

### NOTICE

The GFCI circuit breaker should be tested at least once a month. **NEVER** perform the GFCI circuit breaker test with the engine running at low speed (idle control switch ON), damage to the GFCI may occur.

# WELDER/GENERATOR WIRING DIAGRAM

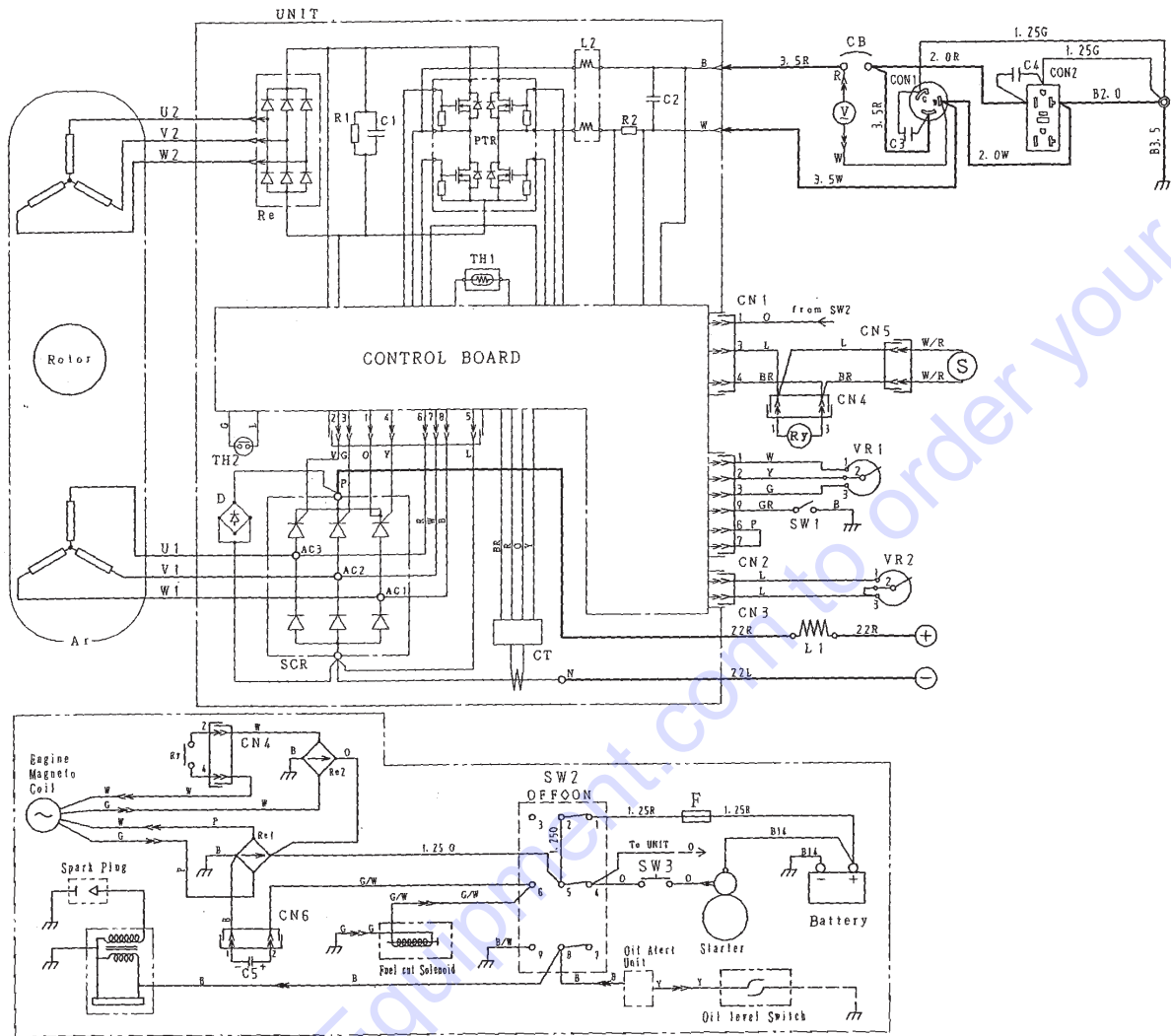

COLOR CODE			
WIRE COLOR	WIRE COLOR		
B	BLACK	R	RED
L	BLUE	W	WHITE
BR	BROWN	Y	YELLOW
G	GREEN	LB	LIGHT BLUE
GR	GRAY	LG	LIGHT GREEN
V	VIOLET	O	ORANGE
P	PINK		

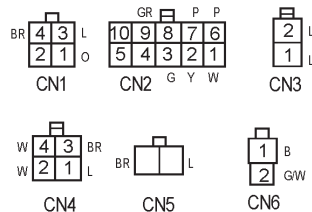

CONNECTOR ARRANGEMENT  
(VIEW FROM INSERTING WIRE SIDE)

SYMBOL	DESIGNATION
Ar	ARMATURE WINDING
ROTOR	ROTOR ASSEMBLY
CB	CIRCUIT BREAKER 25A
Ex W2	EXCITATION WINDING
CON 1	RECEPTACLE L5-30R 30A 125V/250V
CON 2	RECEPTACLE 5-20R 20A, 125V
V	AC VOLTMETER 120/240V
C3, C4	SURGE FILTER
SW1	IDLE CONTROL SWITCH
VR1	CURRENT REGULATOR
VR2	ARC FORCE REGULATOR
L1	DC REACTOR
⊕ ⊖	WELDING OUTPUT TERMINALS
SW2	OPERATION SWITCH
SW3	STARTER SWITCH
RE 1~2	RECTIFIER
S	IDLE CONTROL SOLENOID
RY	RELAY
C5	CAPACITOR
F	FUSE

## TROUBLESHOOTING (WELDER/GENERATOR)

Troubleshooting (Welder/Generator )		
Symptom	Possible Problem	Solution
No Arcing	Loose or disconnected wires?	Check wire connections.
	Defective generator?	Check or replace generator.
	Defective control unit?	Check or replace control unit
	Defective current regulator?	Check or replace current regulator.
	Defective output terminals	Replace output terminals.
Current or ARC force regulator not working properly	Loose or disconnected wires?	Check wire connections.
	Defective control unit?	Replace control unit.
	Defective current or ARC force regulator?	Replace current or ARC force regulator.
No AC voltage output.	Loose or disconnected wires?	Check wire connections.
	Defective generator?	Check or replace generator.
	Defective control unit?	Replace control unit.
	Defective circuit breaker?	Replace circuit breaker.
Overheating	Overload?	Reduce load.
	Poor ventilation?	Check air space around welder-generator. Make sure there is at least 3.0 ft./1 meter clearance on all sides of the welder-generator.
	Stator winding malfunction?	Check or replace stator.
	Leakage breaker malfunction?	Check or replace CB1.
Low voltage	Engine speed too low?	Raise engine speed to rated RPM.
Low voltage, 3650 RPM (unloaded), 2600 RPM (idle)	AC voltmeter not working?	Replace AC voltmeter.
	Control box internal wiring malfunction?	Check control box wiring.
	Rotor winding malfunction?	Check or replace rotor.
	Stator winding malfunction?	Check or replace stator.
	Leakage breaker malfunction?	Check or replace CB1.

## TROUBLESHOOTING WELDER/GENERATOR)

Troubleshooting (Welder/Generator )-continued		
Symptom	Possible Problem	Solution
Voltage output too high.	Engine speed too high?	Lower engine speed to rated RPM.
Voltage output too high. Engine speed normal 3650 RPM (unloaded), 2500 RPM (idle)	Control box internal wiring malfunction	Check control box wiring.
Circuit breaker will not turn on "NO LOAD"	Defective circuit breaker?	Replace circuit breaker.
	Loose connection?	Inspect connections.
Circuit breaker will turn on "LOADED" but trips immediately.	Overload Condition?	Reduce load or replace breaker.
	Load circuit is shorted?	Check load circuit for short.
	Loose connection?	Inspect connections.
Does not accelerate from low to high "NO LOAD"	Stuck solenoid?	Check solenoid.
	Bad Idle control switch?	Check or replace idle control switch.
Does not accelerate from low to high "LOAD ACTIVE"	Idle control switch malfunction?	Check or replace idle control switch.
	Idle control device malfunction?	Check or replace idle control device.
	Control box internal wiring defective?	Check control box wiring.
Does not decelerate but has "VOLTAGE OUTPUT".	Control box wiring malfunction?	Check control box wiring, replace any defective components.
	Defective solenoid?	Check or replace solenoid.
	Idle control device malfunction?	Check or replace idle control device.

## TROUBLESHOOTING (ENGINE)

Troubleshooting (Engine)		
Symptom	Possible Problem	Solution
Difficult to start, fuel is available, but no spark at spark plug.	Spark plug bridging?	Check gap, insulation or replace spark plug.
	Carbon deposit on spark plug?	Clean or replace spark plug.
	Short circuit due to deficient spark plug insulation?	Check spark plug insulation, replace if worn.
	Improper spark plug gap?	Set to proper gap.
	Spark plug is red?	Check transistor ignition unit.
	Spark plug is bluish white?	If insufficient compression, repair or replace engine. If injected air leaking, correct leak. If carburetor jets clogged, clean carburetor.
	No spark present at tip of spark plug?	Check if transistor ignition unit is broken, and replace defective unit. Check if voltage cord cracked or broken and replace. Check if spark plug if fouled and replace.
	No oil?	Add oil as required.
	Oil pressure alarm lamp blinks upon starting? (if applicable)	Check automatic shutdown circuit, "oil sensor". (if applicable)
Difficult to start, fuel is available, and spark is present at the spark plug.	ON/OFF switch is shorted?	Check switch wiring, replace switch.
	Ignition coil defective?	Replace ignition coil.
	Improper spark gap, points dirty?	Set correct spark gap and clean points.
	Condenser insulation worn or short circuiting?	Replace condenser.
	Spark plug wire broken or short circuiting?	Replace defective spark plug wiring.
Difficult to start, fuel is available, spark is present and compression is normal.	Wrong fuel type?	Flush fuel system, replace with correct type of fuel.
	Water or dust in fuel system?	Flush fuel system.
	Air cleaner dirty?	Clean or replace air cleaner.
	Choke open?	Close choke.
Difficult to start, fuel is available, spark is present and compression is low.	Suction/exhaust valve stuck or protruded?	Reseat valves.
	Piston ring and/or cylinder worn?	Replace piston rings and/or piston.
	Cylinder head and/or spark plug not tightened properly?	Torque cylinder head bolts and spark plug.
	Head gasket and/or spark plug gasket damaged?	Replace head and spark plug gaskets.
No fuel present at carburetor.	No fuel in fuel tank?	Fill with correct type of fuel.
	Fuel cock does not open properly?	Apply lubricant to loosen fuel cock lever, replace if necessary.
	Fuel filter/lines clogged?	Replace fuel filter.
	Fuel tank cap breather hole clogged?	Clean or replace fuel tank cap.
	Air in fuel line?	Bleed fuel line.

## TROUBLESHOOTING (ENGINE)

Troubleshooting (Engine) - continued		
Symptom	Possible Problem	Solution
Weak in power, compression is proper and does not misfire.	Air cleaner dirty?	Clean or replace air cleaner.
	Improper level in carburetor?	Check float adjustment, rebuild carburetor.
	Defective spark plug?	Clean or replace spark plug.
	Improper spark plug?	Set to proper gap.
Weak in power, compression is proper but misfires.	Water in fuel system?	Flush fuel system and replace with correct type of fuel.
	Dirty spark plug?	Clean or replace spark plug.
	Ignition coil defective?	Replace ignition coil.
Engine overheats	Wrong type of fuel?	Replace with correct type of fuel.
	Cooling fins dirty?	Clean cooling fins.
	Intake air restricted?	Clear intake of dirt and debris. Replace air cleaner elements as necessary.
	Oil level too low or too high?	Adjust oil to proper level.
Rotational speed fluctuates.	Governor adjusted incorrectly?	Adjust governor.
	Governor spring defective?	Replace governor spring.
	Fuel flow restricted?	Check entire fuel system for leaks or clogs.
Recoil starter malfunctions. (if applicable)	Recoil mechanism clogged with dust and dirt?	Clean recoil assembly with soap and water.
	Spiral spring loose?	Replace spiral spring.
Starter malfunctions.	Loose, damaged wiring?	Ensure tight, clean connections on battery and starter.
	Battery insufficiently charged?	Recharge or replace battery.
	Starter damaged or internally shorted?	Replace starter.
Burns too much fuel.	Over-accumulation of exhaust products?	Check and clean valves. Check muffler and replace if necessary.
	Wrong spark plug?	Replace spark plug with manufacturer's suggested type.
Exhaust color is continuously "white".	Lubricating oil is wrong viscosity?	Replace lubricating oil with correct viscosity.
	Worn rings?	Replace rings.
Exhaust color is continuously "black".	Air cleaner clogged?	Clean or replace air cleaner.
	Choke valve set to incorrect position?	Adjust choke valve to correct position.
	Carburetor defective, seal on carburetor broken?	Replace carburetor or seal.
	Poor carburetor adjustment, engine runs too rich?	Adjust carburetor.
Will not start, no power with key "ON". (if applicable)	ON/OFF device not activated ON?	Turn on ON/OFF device.
	Battery disconnected or discharged?	Check cable connections. Charge or replace battery
	Ignition switch/wiring defective?	Replace ignition switch. Check wiring.



# EXPLANATION OF CODE IN REMARKS COLUMN

The following section explains the different symbols and remarks used in the Parts section of this manual. Use the help numbers found on the back page of the manual if there are any questions.

## NOTICE

The contents and part numbers listed in the parts section are subject to change **without notice**. Multiquip does not guarantee the availability of the parts listed.

## SAMPLE PARTS LIST

NO.	PART NO.	PART NAME	QTY.	REMARKS
1	12345	BOLT .....	1	INCLUDES ITEMS W/%
2%		WASHER, 1/4 IN. ....		NOT SOLD SEPARATELY
2%	12347	WASHER, 3/8 IN. ...	1	MQ-45T ONLY
3	12348	HOSE .....	A/R	MAKE LOCALLY
4	12349	BEARING .....	1	S/N 2345B AND ABOVE

## NO. Column

**Unique Symbols** — All items with same unique symbol (@, #, +, %, or >) in the number column belong to the same assembly or kit, which is indicated by a note in the “Remarks” column.

**Duplicate Item Numbers** — Duplicate numbers indicate multiple part numbers, which are in effect for the same general item, such as different size saw blade guards in use or a part that has been updated on newer versions of the same machine.

## NOTICE

When ordering a part that has more than one item number listed, check the remarks column for help in determining the proper part to order.

## PART NO. Column

**Numbers Used** — Part numbers can be indicated by a number, a blank entry, or TBD.

TBD (To Be Determined) is generally used to show a part that has not been assigned a formal part number at the time of publication.

A blank entry generally indicates that the item is not sold separately or is not sold by Multiquip. Other entries will be clarified in the “Remarks” Column.

## QTY. Column

**Numbers Used** — Item quantity can be indicated by a number, a blank entry, or A/R.

A/R (As Required) is generally used for hoses or other parts that are sold in bulk and cut to length.

A blank entry generally indicates that the item is not sold separately. Other entries will be clarified in the “Remarks” Column.

## REMARKS Column

Some of the most common notes found in the “Remarks” Column are listed below. Other additional notes needed to describe the item can also be shown.

**Assembly/Kit** — All items on the parts list with the same unique symbol will be included when this item is purchased.

Indicated by:

“INCLUDES ITEMS W/(unique symbol)”

**Serial Number Break** — Used to list an effective serial number range where a particular part is used.

Indicated by:

“S/N XXXXX AND BELOW”

“S/N XXXX AND ABOVE”

“S/N XXXX TO S/N XXX”

**Specific Model Number Use** — Indicates that the part is used only with the specific model number or model number variant listed. It can also be used to show a part is NOT used on a specific model or model number variant.

Indicated by:

“XXXXX ONLY”

“NOT USED ON XXXX”

**“Make/Obtain Locally”** — Indicates that the part can be purchased at any hardware shop or made out of available items. Examples include battery cables, shims, and certain washers and nuts.

**“Not Sold Separately”** — Indicates that an item cannot be purchased as a separate item and is either part of an assembly/kit that can be purchased, or is not available for sale through Multiquip.

## SUGGESTED SPARE PARTS

### GAW180HE/HE1/HEA PORTABLE 60 HZ WELDER GENERATORS

1 to 3 units

Qty.	P/N	Description
1◆	D1364000003	CAP FUEL TANK
1◇	D1364000803	CAP FUEL TANK S/N 5629880 AND BELOW
1◇	D1361000004	CAP FUEL TANK S/N 5629881 AND ABOVE
1❖	D1361000004	CAP FUEL TANK
2	1665115504	RUBBER SUSPENSION
2◆◇	1665419004	RUBBER SUSPENSION
2❖	A9312601104	RUBBER SUSPENSION
3	16952ZB4005	FUEL STRAINER
1	0605505130	FILTER FUEL
3	0601823208	RECTIFIER
3	0601823218	RECTIFIER
3	0601821104	THYRISTOR
3	0601802137	FUSE, 10 AMP

#### NOTICE

Part numbers on this Suggested Spare Parts list may supersede/replace the part numbers shown in the following parts lists.

#### NOTICE

- ◆ GAW180HE
- ◇ GAW180HE1
- ❖ GAW180HEA

### HONDA GX340K1EDE2/GX340RT2EDE2 GASOLINE ENGINES

1 to 3 units

Qty.	P/N	Description
3◆	9807955846	SPARK PLUG
3◇	9807955876	SPARK PLUG
1◆	5510ZE2043	SWITCH ASSY., OIL ALERT
1◇	35480ZF6003	SWITCH ASSY., OIL ALERT
2	28462ZV7003	ROPE, RECOIL
3	17211899000	ELEMENT AIR CLEANER

#### NOTICE

- ◆ GX340K1EDE2
- ◇ GX340RT2EDE2

# NAMEPLATE AND DECALS ASSY.

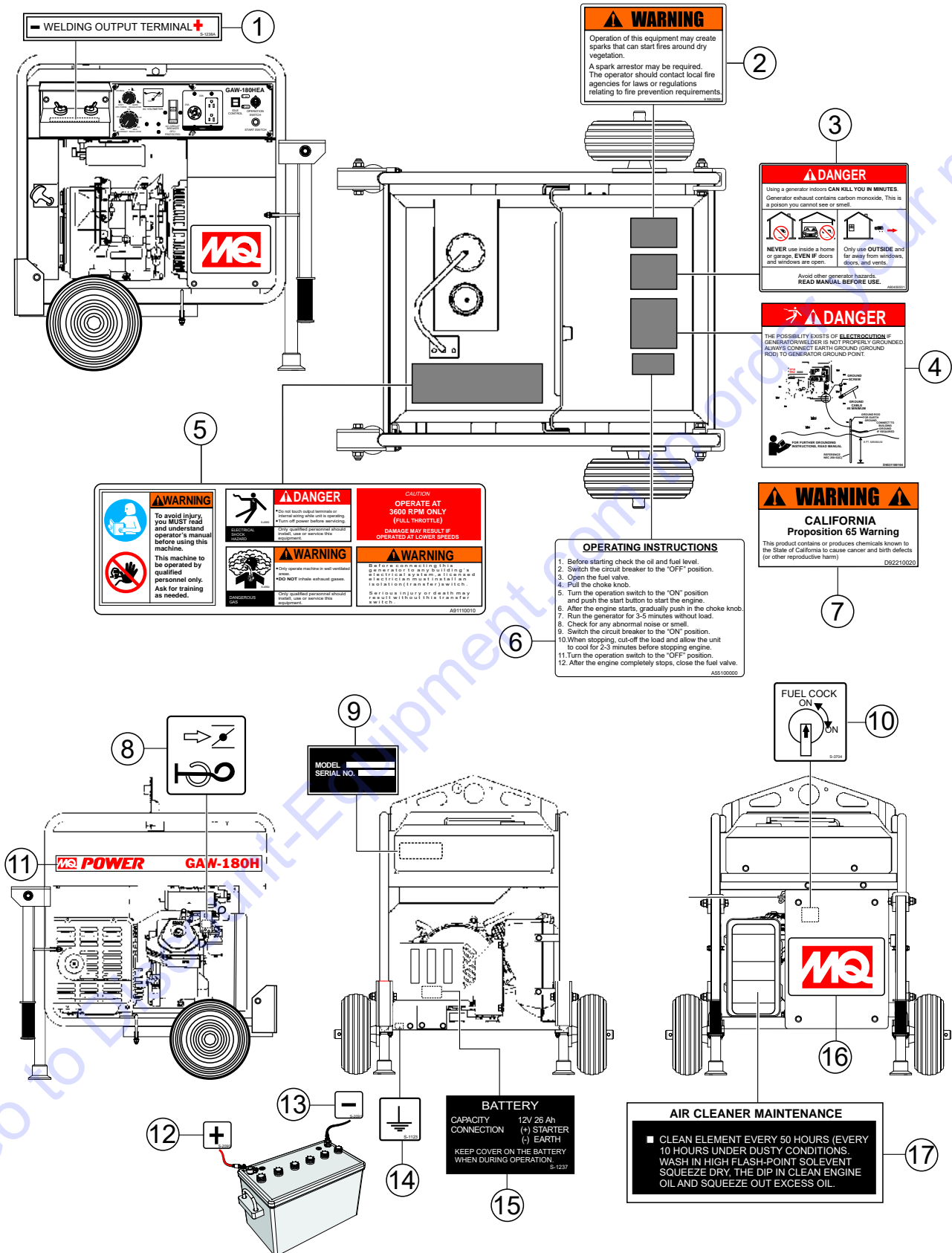

## NAMEPLATE AND DECALS ASSY.

<u>NO.</u>	<u>PART NO.</u>	<u>PART NAME</u>	<u>QTY.</u>	<u>REMARKS</u>
1	0800690804	DECAL; WELDING OUTPUT TERMINAL.....	1.....	S-1238A REPLACES P/N W0800690804
2	920214100	DECAL; WARNING START FIRES .....	1.....	M90420000 REPLACES P/N M9504200004
3	A9504000014	DECAL; WARNING DANGEROUS GAS .....	1.....	A90400001
4	D9531100104	DECAL; DANGER ELECTROCUTION .....	1.....	D93110010
5	A9511100103	DECAL; WARNING .....	1.....	A91110010
6	A5551000004	DECAL; OPERATING INSTRUCTIONS .....	1.....	A55100000
7	DCL160	DECAL; WARNING .....	1.....	D92210020 REPLACES P/N D9522100204
8	87528898620	DECAL; CHOKE .....	1.....	REPLACES P/N 0600500047
9		DECAL; NAMEPLATE.....	1	
10	W1980680004	DECAL; FUEL COCK .....	1.....	S-3704
11	D1561001703	DECAL; MQ MULTIQUIP GAW180H	1	
12	0800689404	DECAL; + .....	1.....	S-2090 REPLACES P/N W0800689404
13	0800689504	DECAL; - .....	1.....	S-2091 REPLACES P/N W0800689504
14	0800628504	DECAL; GROUND .....	1.....	S-1123 REPLACES P/N W0800628504
15	0800696804	DECAL; BATTERY .....	1.....	S-1237 REPLACES P/N W0800696604
16	D1561001803	DECAL; MQ LOGO	1	
17	87533ZC0630	DECAL; AIR CLEANER .....	1.....	REPLACES P/N 0600500045

**GENERATOR ASSY.**

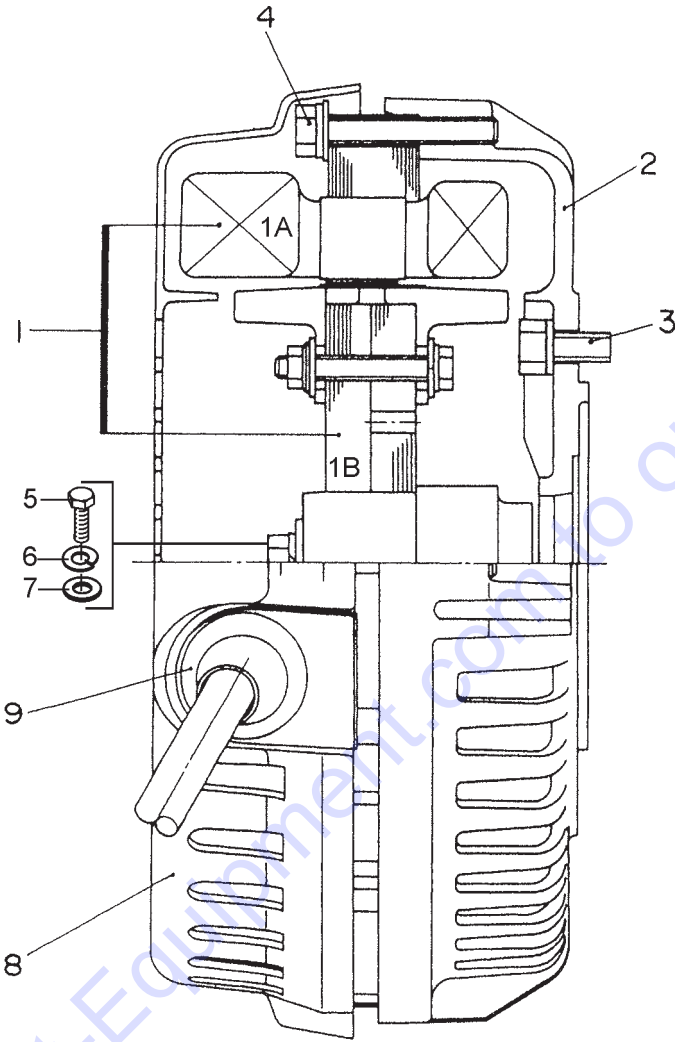

## GENERATOR ASSY.

<u>NO.</u>	<u>PART NO.</u>	<u>PART NAME</u>	<u>QTY.</u>	<u>REMARKS</u>
1A	D1135000002	ARMATURE ASSY.	1	
1B	D1110200603	ROTOR ASSY.	1	
2	D1155100802	END BRACKET	1	
3	0012808020	HEX. HEAD BOLT	4	
4	0012308055	HEX. HEAD BOLT	4	
5	0010710060	HEX. HEAD BOLT	1	
6	0040010000	WASHER, LOCK	1	
7	0801086104	WASHER	1	
8	D1153400212B	COVER .....	1	REPLACES P/N D1153400212
9	D1153300114	GROMMET	2	

Go to Discount-Equipment.com to order your parts

# CONTROL BOX ASSY.

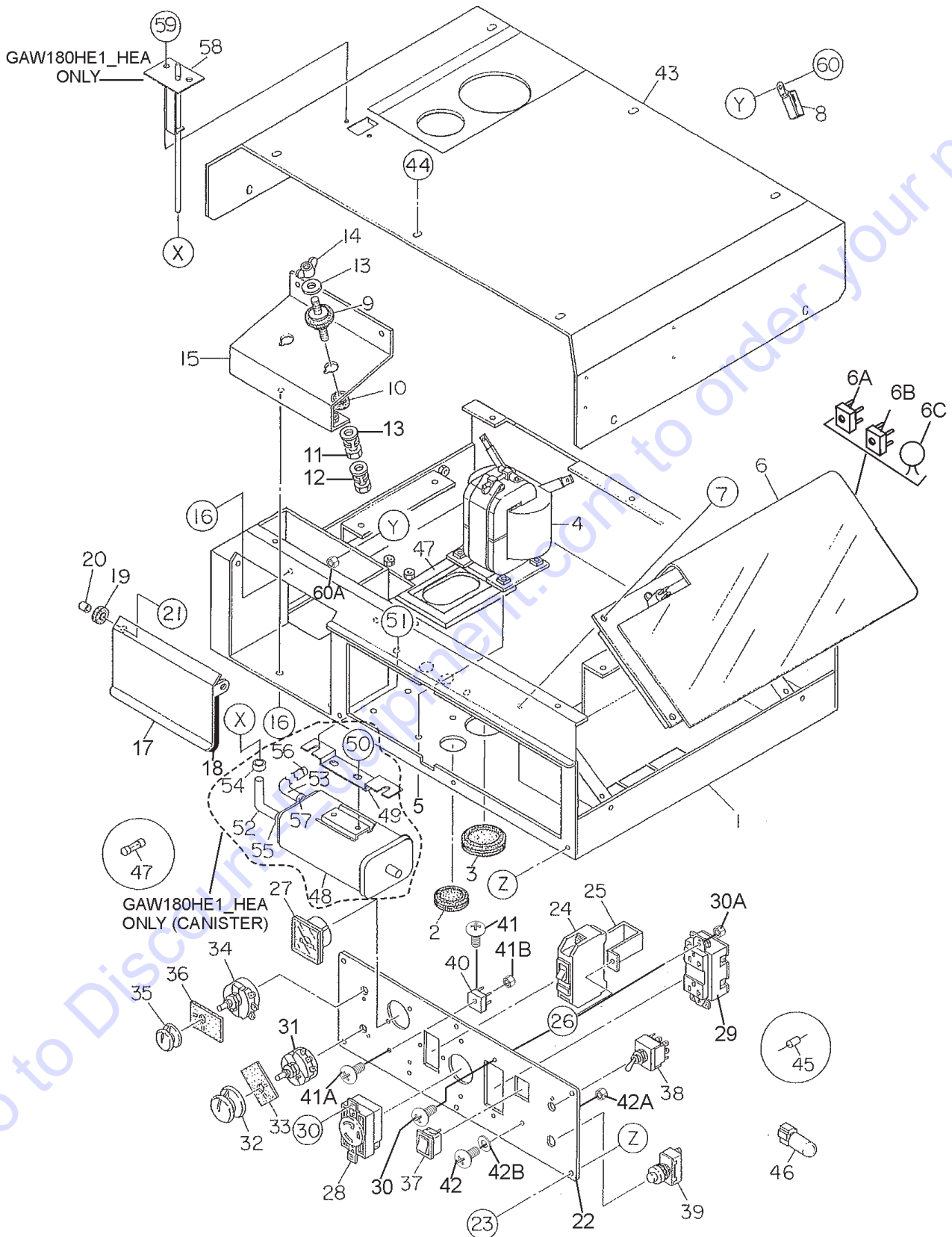

## CONTROL BOX ASSY.

<u>NO.</u>	<u>PART NO.</u>	<u>PART NAME</u>	<u>QTY.</u>	<u>REMARKS</u>
1	D1214000002	CONTROL BOX, (GAW180HE)	1	
1	D1214000102	CONTROL BOX, (GAW180HE1)	1	
1	D1214000202	CONTROL BOX, (GAW180HEA)	1	
2	0601850268	GROMMET	1	
3	0601851769	GROMMET	1	
4	1971885003	DC REACTOR	1	
5	011106016	HEX. HEAD BOLT KIT, (GAW180HE)	4	
5	0017106016	HEX. HEAD BOLT KIT, (GAW180HE1)	4	
5	011106015	HEX. HEAD BOLT, (GAW180HEA) .....	4	REPLACES P/N 0017106015
6	D9924800034	CONTROL UNIT	1	
6A	0601823208	RECTIFIER	1	
6B	0601823218	RECTIFIER	1	
6C	0601821104	THYRISTOR	1	
7	011106016	HEX. HEAD BOLT KIT, (GAW180HE)	4	
7	0017106016	HEX. HEAD BOLT KIT, (GAW180HE1)	4	
7	011106015	HEX. HEAD BOLT, (GAW180HEA) .....	4	REPLACES P/N 0017106015
8	0601823707	RELAY	1	
9	D1233000004A	OUTPUT TERMINAL .....	2	REPLACES P/N D1233000004
10	0801880004	INSULATOR WASHER	2	
11	020310080	HEX. NUT .....	4	REPLACES P/N 0039510000
12	0042210000	WASHER, LOCK	4	
13	0041410000	WASHER, FLAT	8	
14	0037810000	WING NUT	2	
15	D1232800004	BRACKET	1	
16	011106015	HEX. HEAD BOLT .....	4	REPLACES P/N 0017106015
17	D1238100504	COVER, OUTPUT TERMINAL	1	
18	D1234400004	RUBBER SHEET	1	
19	0805088004	RUBBER WASHER	1	
20	0805088304	COLLAR	2	
21	011206020	HEX. HEAD BOLT .....	2	REPLACES P/N 0016906020
22	D1352100003	CONTROL PANEL, (GAW180HE) .....	1	D151200102
22	D1511200102	CONTROL PANEL, (GAW180HE1) .....	1	S/N 5645998 AND BELOW D1352100003
22	D1511200112	CONTROL PANEL, (GAW180HE1) .....	1	S/N 5645999 AND ABOVE D1352100013
22	D1511200202	CONTROL PANEL, (GAW180HEA) .....	1	D1352100013
23	0021805012	MACHINE SCREW	6	
24	0601807454	CIRC. BREAKER 120V, 25A 1P (GAW180HE)	1	
24	0601807454	CIRC. BREAKER 120V, 25A 1P (GAW180HE1)1.....	1	S/N 5645998 AND BELOW
24	0601870453	CIRC BREAKER 120V, 25A 1P (GAW180HE1) 1.....	1	S/N 5645999 AND ABOVE
24	0601870453	CIRC. BREAKER 120V, 25A 1P GAW180HEA) 1	1	
25	3011816004	BRACKET, CIRCUIT BREAKER	1	
26	0021004020	MACHINE SCREW	2	
27	0601806819	AC VOLTMETER 120V/240V	1	
28	0601811031	RECEPTACLE L5-30R.....	1	REPLACES P/N 0601811035



# CONTROL BOX ASSY.

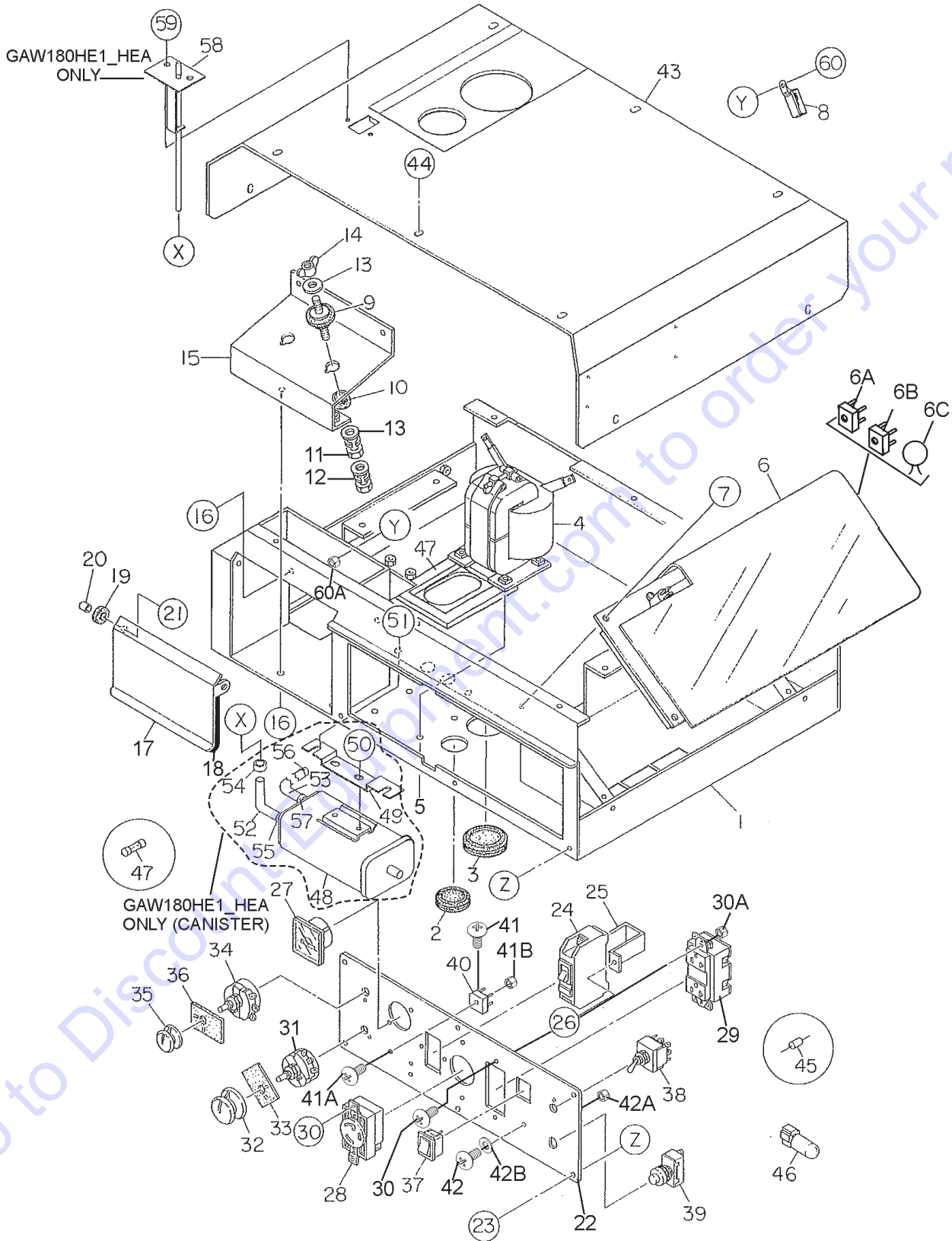

## CONTROL BOX ASSY.

NO.	PART NO.	PART NAME	QTY.	REMARKS
29	0601812597	RECEPTACLE 5-20R, (GAW180HE)	1	
29	0601812597	RECEPTACLE 5-20R, (GAW180HE1).....	1.....	REPLACES P/N 0601812598 S/N 5609877 AND BELOW
29	0601814013	RECEPTACLE 5-20R, (GAW180HE1).....	1.....	S/N 5609878 AND ABOVE
29	0601814065	RECEPTACLE 5-20R, (GAW180HEA)	1	
30	0021004010	MACHINE SCREW	4	
30A	OEMAA8	HEX. NUT .....	4.....	REPLACES P/N 0207004000
31	0601840028	RHEOSTAT, CURRENT REGULATOR	1	
32	0601840103	KNOB	1	
33	0801883003	INSULATOR	1	
34	0601840095	RHEOSTAT, ARC FORCE	1	
35	0601840100	KNOB	1	
36	0801883003	INSULATOR	1	
37	0601831620	SWITCH, IDLE CONTROL	1	
38	0601830737	OPERATION SWITCH	1	
39	0602100102	START SWITCH	1	
40	0601823204	RECTIFIER	1	
41	0027103015	MACHINE SCREW	2	
41A	0027103008	MACHINE SCREW	1	
41B	0207003000	HEX. NUT	3	
42	0021004020	MACHINE SCREW	1	
42A	OEMAA8	HEX. NUT .....	3.....	REPLACES P/N 0207004000
42B	58042	WASHER, FLAT .....	2.....	REPLACES P/N 0041204000
43	D1214500103	COVER	1	
44	0017106016	HEX. HEAD BOLT KIT, (GAW180HE_HE1)	10	
44	011106015	HEX. HEAD BOLT, (GAW180HEA).....	10.....	REPLACES P/N 0016906015
45	0601826150	CAPACITOR, 250 VAC @ 0.1µF	1	
46	A3262800004	CAPACITOR, 50 VAC @ 1000µF	1	
47	0601802137	FUSE, 10 AMP	1	
48♦	0605507001	CANISTER	1	
49♦	A1261601004	BRACKET	1	
50♦	Y0021806012	MACHINE SCREW	2	
51♦	011106015	HEX. HEAD BOLT .....	2.....	REPLACES P/N 0016906015
52♦	Y0605513204	HOSE	1	
53♦	Y0605513211	HOSE	1	
54♦	0605515223	HOSE BAND	1	
55♦	0605515224	HOSE BAND	1	
56♦	Y0605515229	HOSE BAND	1	
57♦	0605515170	HOSE BAND	1	
58	A1261500004	SET PLATE, (GAW180HE1_HEA)	1	
59	011106015	HEX. HEAD BOLT, (GAW180HE1_HEA).....	2.....	REPLACES P/N 0016906015
60	0027105016	MACHINE SCREW, PAN HD 5X15"	1	
60A	0030005000	HEX. NUT .....	1.....	REPLACES P/N 0207005000

### NOTICE

- ♦ CANISTER AND ASSOCIATED MOUNTING  
HARDWARE INCLUDED ON GAW180HE1\_HEA  
MODELS ONLY.

# PARTS FINDER

**Search Website  
by Part Number**



**Search Manual  
Library For Parts  
Manual & Lookup Part  
Numbers – Purchase  
or Request Quote**

**Search Manuals**

Enter your information to help us find the right parts manual for your machine.

\* Brand:

\* Model:

\* Serial:

\* Part Number:

SEARCH

**Can't Find Part or  
Manual? Request Help  
by Manufacturer,  
Model & Description**

**Parts Order Form**

Please fill in the following information to help us find the right part for your machine.

Manufacturer:	<input type="text"/>
Model:	<input type="text"/>
Description:	<input type="text"/>
Part Number:	<input type="text"/>
Quantity:	<input type="text"/>
Notes:	<input type="text"/>

Submit

Discount-Equipment.com is your online resource for quality parts & equipment.

Florida: **561-964-4949** Outside Florida TOLL FREE: **877-690-3101**

**Need parts?**

Click on this link: <http://www.discount-equipment.com/category/5443-parts/> and choose one of the options to help get the right parts and equipment you are looking for. Please have the machine model and serial number available in order to help us get you the correct parts. If you don't find the part on the website or on one of the online manuals, please fill out the request form and one of our experienced staff members will get back to you with a quote for the right part that your machine needs.

We sell worldwide for the brands: Genie, Terex, JLG, MultiQuip, Mikasa, Essick, Whiteman, Mayco, Toro Stone, Diamond Products, Generac Magnum, Airman, Haulotte, Barreto, Power Blanket, Nifty Lift, Atlas Copco, Chicago Pneumatic, Allmand, Miller Curber, Skyjack, Lull, Skytrak, Tsurumi, Husquvarna Target, Stow, Wacker, Sakai, Mi-T-M, Sullair, Basic, Dynapac, MBW, Weber, Bartell, Bennar Newman, Haulotte, Ditch Runner, Menegotti, Morrison, Contec, Buddy, Crown, Edco, Wyco, Bomag, Laymor, EZ Trench, Bil-Jax, F.S. Curtis, Gehl Pavers, Heli, Honda, ICS/PowerGrit, IHI, Partner, Imer, Clipper, MMD, Koshin, Rice, CH&E, General Equipment, Amida, Coleman, NAC, Gradall, Square Shooter, Kent, Stanley, Tamco, Toku, Hatz, Kohler, Robin, Wisconsin, Northrock, Oztec, Toker TK, Rol-Air, APT, Wylie, Ingersoll Rand / Doosan, Innovatech, Con X, Ammann, Mecalac, Makinex, Smith Surface Prep, Small Line, Wanco, Yanmar

# PIPE FRAME ASSY.

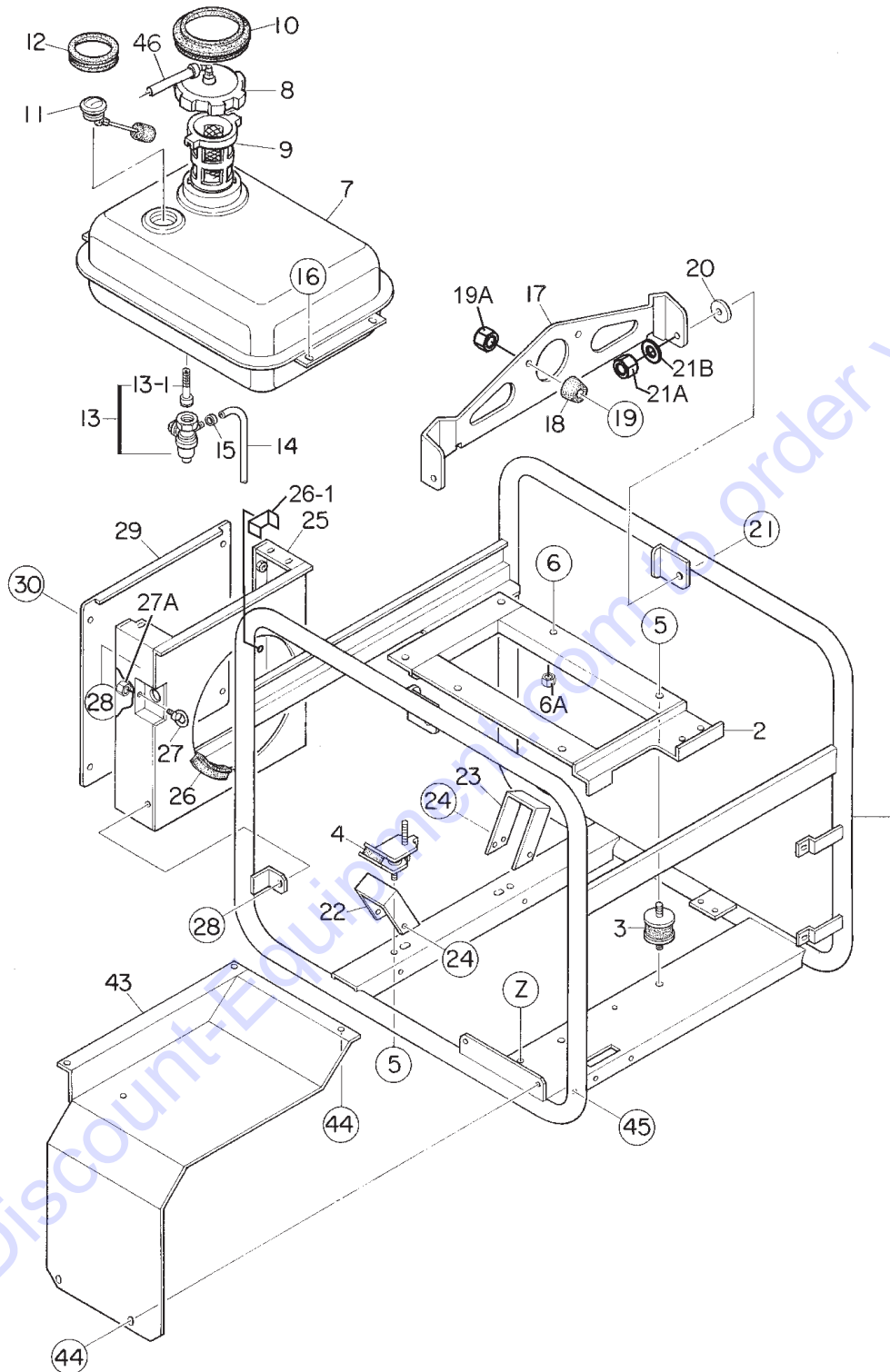

## PIPE FRAME ASSY.

<u>NO.</u>	<u>PART NO.</u>	<u>PART NAME</u>	<u>QTY.</u>	<u>REMARKS</u>
1	D1417000002	PIPE FRAME, (GAW180HE)	1	
1	D1417000702	PIPE FRAME, (GAW180HE1)	1	
1	D1417001102	PIPE FRAME, (GAW180HEA)	1	
2	D1304100004	BASE	1	
3	1665115504	RUBBER SUSPENSION	2	
4	1665419004	RUBBER SUSPENSION, (GAW180HE_HE1).....	2	REPLACES P/N 1725419214
4	A9312601104	RUBBER SUSPENSION, (GAW180HEA)	2	
5	020108060	HEX. NUT .....	8	REPLACES P/N 0207008000
6	0016908040	HEX. HEAD BOLT	2	
6A	0207008000	HEX. NUT	2	
7	D1364000003	FUEL TANK, (GAW180HE)	1	
7	D1364000803	FUEL TANK, (GAW180HE1) .....	1	S/N 5629880 AND BELOW
7	D1361000004	FUEL TANK, (GAW180HE1) .....	1	S/N 5629881 AND ABOVE
7	D1361000004	FUEL TANK, (GAW180HEA)	1	
8	A9924800024	CAP, FUEL TANK, (GAW180HE) .....	1	REPLACES P/N 0810105804
8	0430430120	CAP, FUEL TANK, (GAW180HE1) .....	1	REPLACES P/N 0605505068
8	0430430120	CAP, FUEL TANK, (GAW180HEA).....	1	REPLACES P/N 0605505068
9	0605505130	FUEL FILTER	1	
10	D1492600104	RUBBER SEAL	1	
11	0602125032	FUEL GAUGE	1	
12	D1490600104	RUBBER SEAL	1	
13	16950ZB4015	FUEL COCK ASSY. ....	1	INCLUDES ITEM W/\$ REPLACES P/N 0605510068
13-1\$	16952KJ9752	FUEL STRAINER.....	1	REPLACES P/N 16952ZB4005
14	16952KJ9752	HOSE, (GAW180HE).....	1	REPLACES P/N 16952ZB4005
14	91424Z5R800	HOSE, (GAW180HE1_HEA)	1	
15	9500202080	HOSE BAND.....	2	REPLACES P/N 0605515178
16	0016908020	HEX. HEAD BOLT	4	
17	A9117200103	HANGER	1	
18	0601850097	STOPPER	1	
19	011208025	MACHINE SCREW .....	1	REPLACES P/N 0021008025
19A	020108060	HEX. NUT .....	1	REPLACES P/N 0207008000
20	A9311100004	PLASTIC WASHER, (GAW180HE)	2	
20	0601851116	PLASTIC WASHER	2	
21	011208025	HEX. HEAD BOLT .....	2	REPLACES P/N 0011308025
21A	020108060	HEX. NUT, (GAW180HE).....	2	REPLACES P/N 0037908000
21A	0207608000	HEX. NUT	2	
21B	0042108000	WASHER, FLAT	2	
22	7915455103	COVER	1	
23	7855455003	COVER	1	

# PIPE FRAME ASSY.

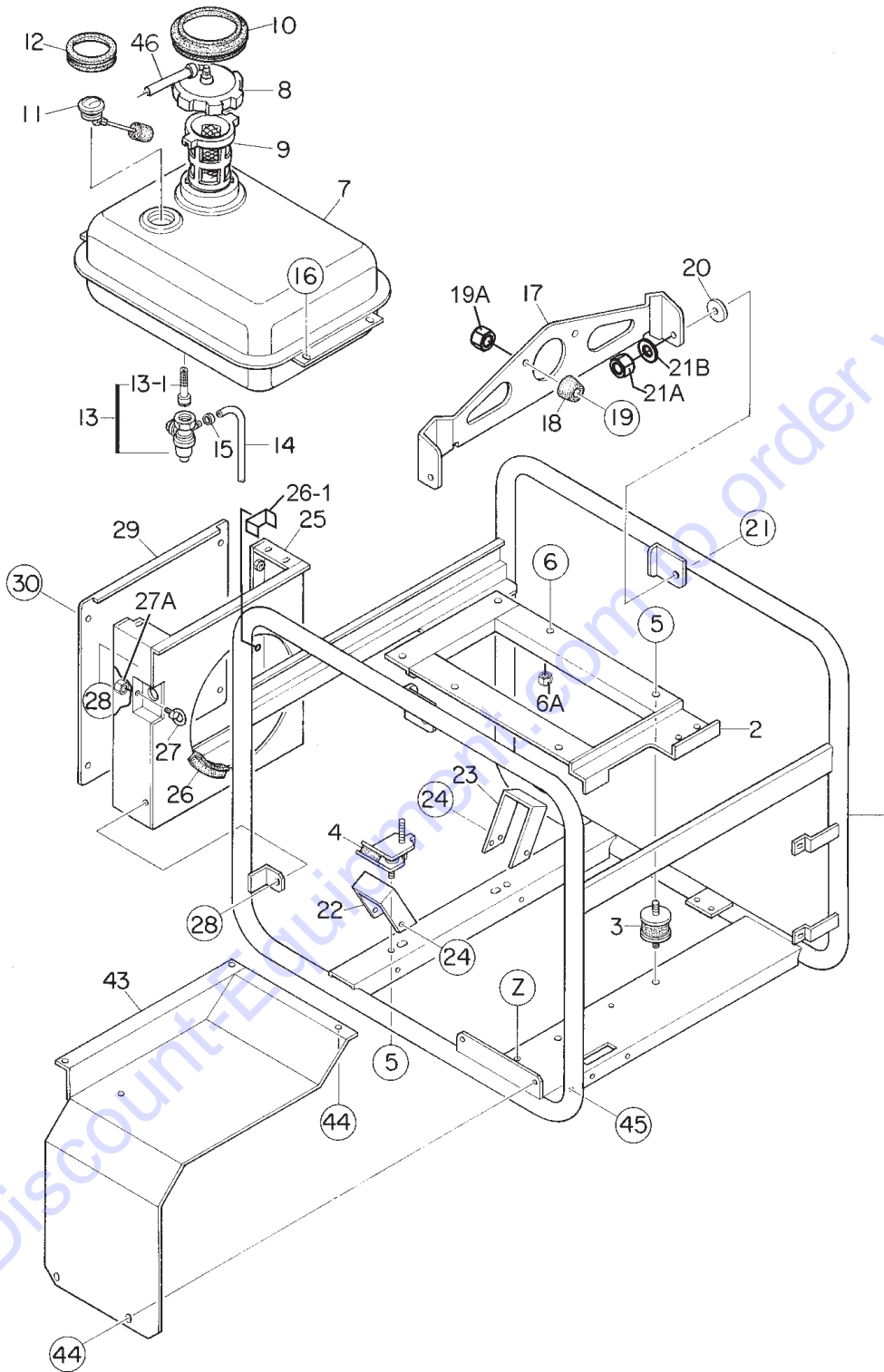

## PIPE FRAME ASSY.

<u>NO.</u>	<u>PART NO.</u>	<u>PART NAME</u>	<u>QTY.</u>	<u>REMARKS</u>
24	0017106016	HEX. HEAD BOLT, (GAW180HE)	6	
24	011106015	HEX. HEAD BOLT.....	6.....	REPLACES P/N 0016906015
25	D1424000003	DUCT, (GAW180HE)	1	
25	D1424000903	DUCT	1	
26	0220300680	RUBBER SEAL, (GAW180HE)	1	
26	Y0314600750	RUBBER SEAL	1	
26-1	Y0027100050	RUBBER SEAL, (GAW180HEA)	1	
27	0014006000	EYE BOLT	1	
27A	0176060030	HEX. NUT .....	1.....	REPLACES P/N 0207006000
28	011106015	HEX. HEAD BOLT.....	3.....	REPLACES P/N 0016906015
29	D1424200204	COVER	1	
30	011106015	HEX. HEAD BOLT.....	4.....	REPLACES P/N 0016906015
43	D1485300903	DUCT, (GAW180HE)	1	
43	D1484300103	DUCT, (GAW180HE1)	1	
43	D1484300103	DUCT, (GAW180HEA) .....	1.....	S/N 5668959 AND BELOW
43	D1484300203	DUCT, (GAW180HEA) .....	1.....	S/N 5668960 AND ABOVE
44	0017106016	HEX. HEAD BOLT, (GAW180HE)	5	
44	011106015	HEX. HEAD BOLT.....	5.....	REPLACES P/N 0016906015
45	0019206016	HEX. HEAD BOLT, (GAW180HE)	1	
45	0019206015	HEX. HEAD BOLT	1	
46	0605513189	HOSE, (GAW180HE1_HEA)	1	

**BATTERY ASSY.**

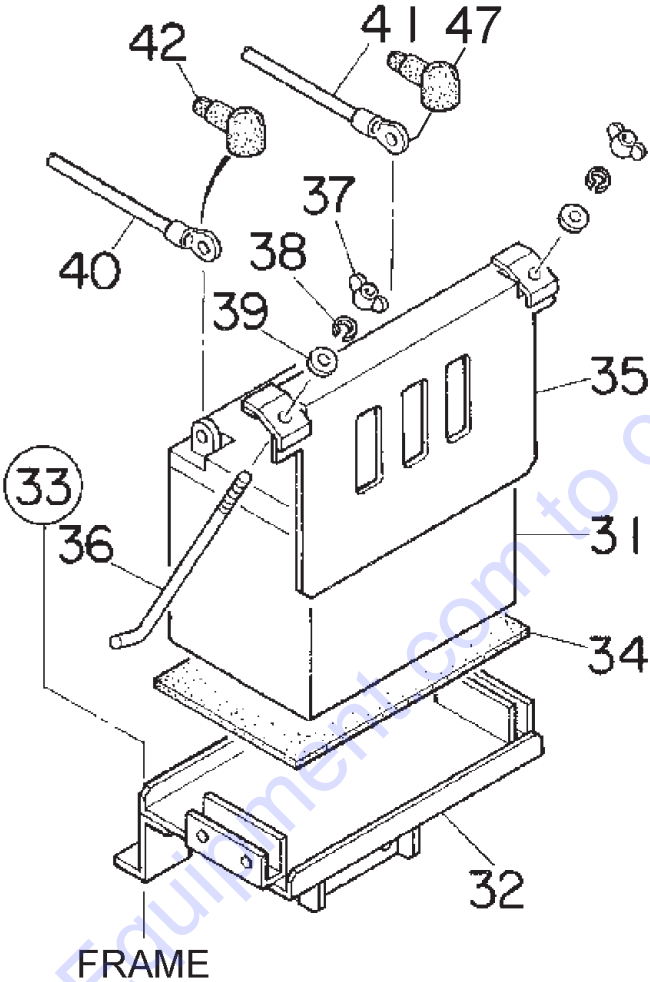



## BATTERY ASSY.

<u>NO.</u>	<u>PART NO.</u>	<u>PART NAME</u>	<u>QTY.</u>	<u>REMARKS</u>
31		BATTERY .....	1.....	PURCHASE LOCALLY
32	D1345200104	BRACKET, BATTERY	1	
33	011106015	HEX. HEAD BOLT .....	4.....	REPLACES P/N 0016906015
34	0805081004	BATTERY SHEET .....	1.....	REPLACES P/N 1702202104
35	7905458103	BATTERY BAND	1	
36	0805082204	BATTERY BOLT	2	
37	0037806000	WING NUT	2	
38	0040006000	WASHER, LOCK	2	
39	952404470	WASHER, FLAT .....	2.....	REPLACES P/N 0041206000
40	D1347000004	BATTERY CABLE	1	
41	D1347000104	BATTERY CABLE	1	
42	D1343200604	TERMINAL CAP	2	
47	Y0602220643	TERMINAL CAP	1	

Go to Discount-Equipment.com to order your parts

# MUFFLER ASSY.

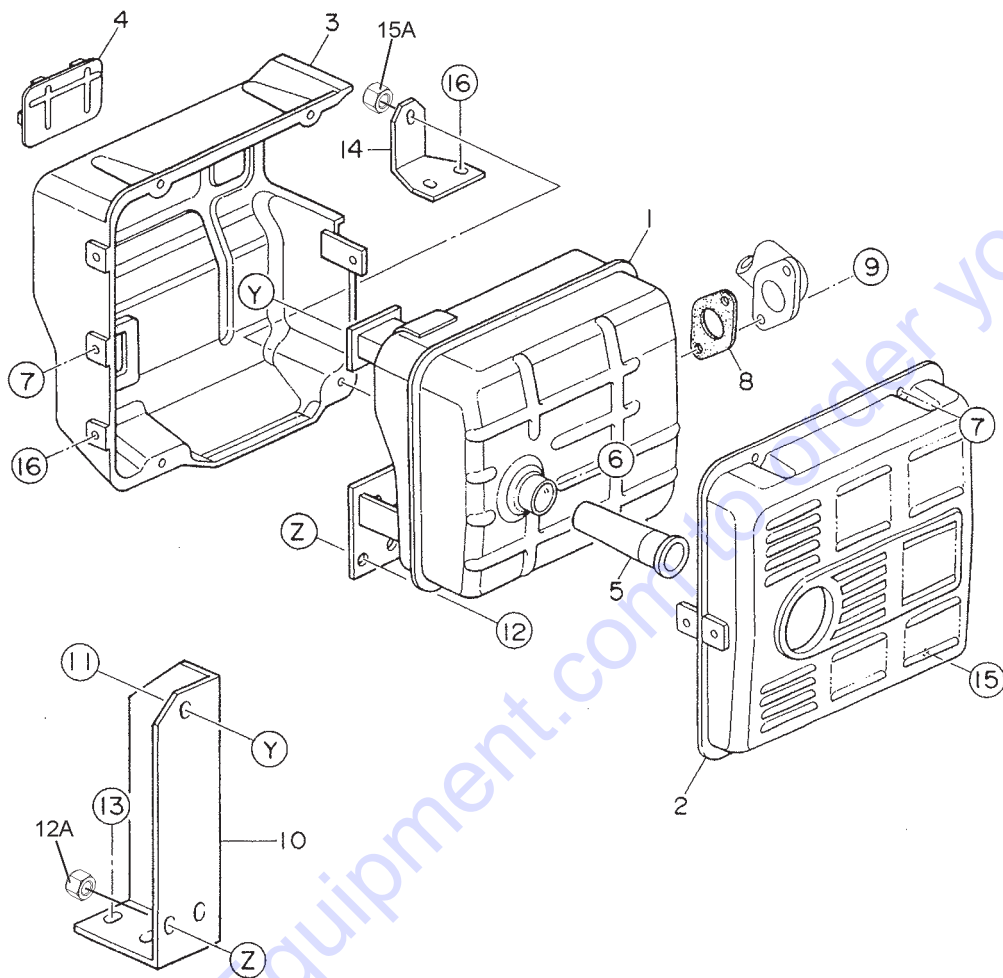

## MUFFLER ASSY.

<u>NO.</u>	<u>PART NO.</u>	<u>PART NAME</u>	<u>QTY.</u>	<u>REMARKS</u>
1	D1331100303	MUFFLER	1	
2	18320ZC2000	PROTECTOR	1	
3	18325ZB4000	PROTECTOR	1	
4	18329ZB4000	SEAL	2	
5	18355ZB4630	ARRESTOR, SPARK	1	
6	90002ZG0003	TAPPING SCREW, (GAW180HE_HE1).....	1.....	REPLACES P/N 90183671003
6	90002ZE2U91	TAPPING SCREW, (GAW180HEA)	1	
7	0105050616	HEX. HEAD BOLT .....	5.....	REPLACES P/N 0017106012
8	18333ZB4801	GASKET	1	
9	957010802000	HEX. HEAD BOLT	2	
10	D1332400104	BRACKET	1	
11	011008020	HEX. HEAD BOLT .....	1.....	REPLACES P/N 0016908020
12	011208025	HEX. HEAD BOLT .....	2.....	REPLACES P/N 0016908025
12A	020108060	HEX. NUT .....	2.....	REPLACES P/N 0207008000
13	011008020	HEX. HEAD BOLT .....	2.....	REPLACES P/N 0016908020
14	D1331400004	BRACKET	1	
15	011206020	HEX. HEAD BOLT .....	1.....	REPLACES P/N 0016906020
15A	0176060030	HEX. NUT .....	1.....	REPLACES P/N 0207006000
16	0016906012	HEX. HEAD BOLT	4	

# UWKB WHEEL KIT ASSY. (OPTION)

19

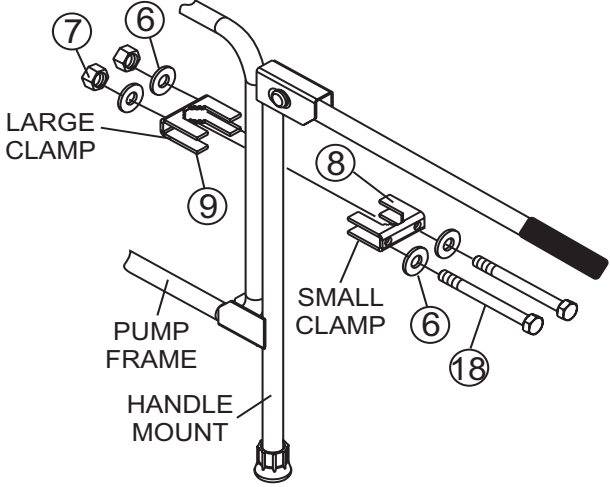
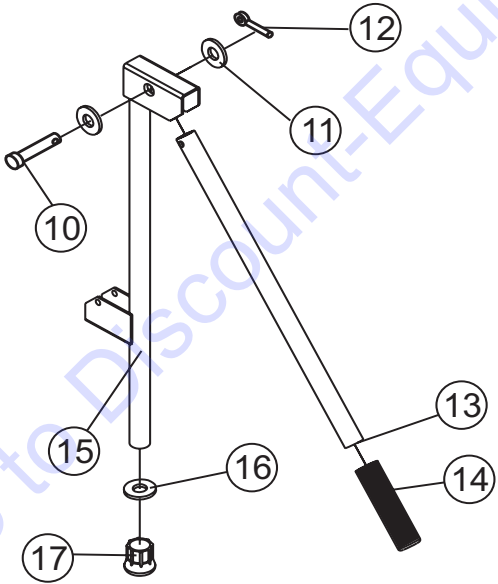
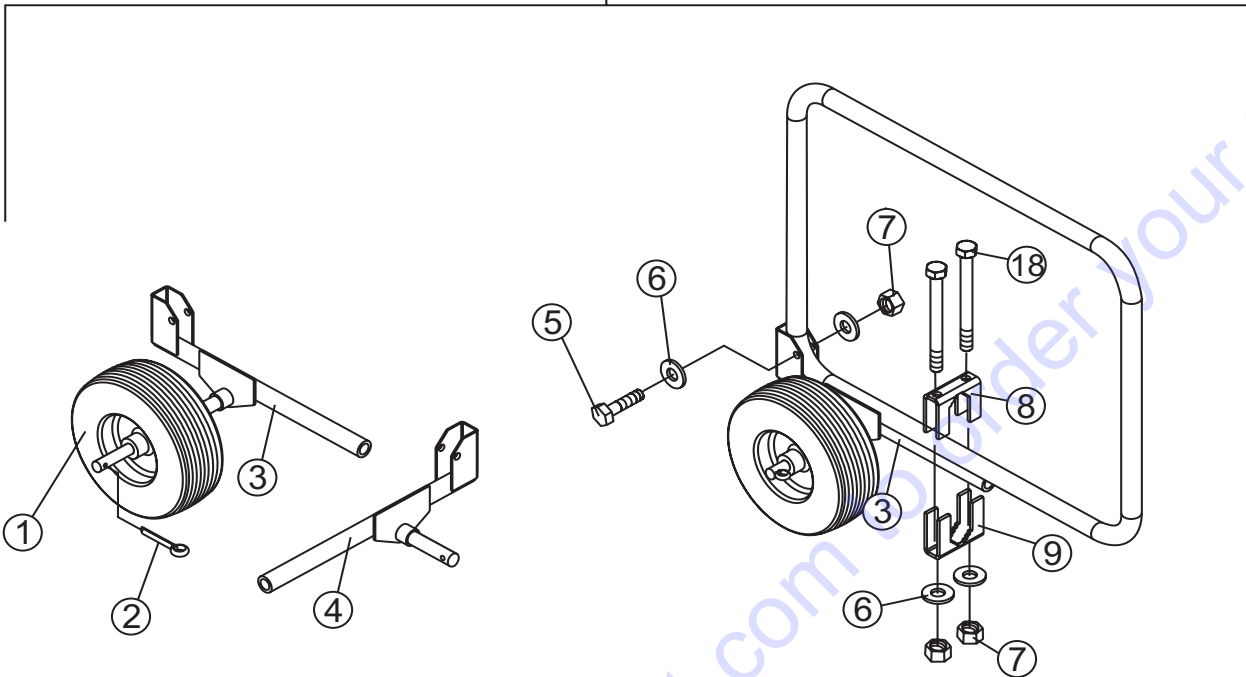

## UWKB WHEEL KIT ASSY. (OPTION)

<u>NO.</u>	<u>PART NO.</u>	<u>PART NAME</u>	<u>QTY.</u>	<u>REMARKS</u>
1#	19850	WHEEL TIRE SOLID .....	2.....	REPLACES P/N WK1312
2#	8158	PIN, COTTER, 3/16" X 1-1/2"	2	
3#	29748	AXLE MOUNT W/A LEFT 3-5/8"	1	
4#	29744	AXLE MOUNT W/A RIGHT 3-5/8"	1	
5#	WK34715	SCREW, M6 X 45	4	
6#	0948	WASHER, FLAT SAE 1/4"	24	
7#	WK34717	NUT, NYLOC M6	12	
8#	WK2250	CLAMP SMALL	4	
9#	WK2300	CLAMP LARGE	4	
10#	29787	PIN, CLEVIS 5/16 X 1-1/2"	2	
11#	0300 B	WASHER, FLAT SAE 5/16"	4	
12#	0683	PIN, COTTER 3/32" X 3/4"	2	
13#	29739	TUBE, HANDLE	2	
14#	15081	GRIP, HAND.....	2.....	REPLACES P/N 19717
15#	29746	HANDLE MOUNT W/A	2	
16#	4001	WASHER FLAT USS 3/8" PLD	2	
17#	19716	CRUTCH TIP	2	
18#	WK34716	SCREW, HHC M6 X 90MM	8	
19	UWKB	WHEEL KIT, UNIVERSAL.....	1.....	INCLUDES ITEMS W/#

Go to Discount-Equipment.com to order your parts

# HONDA GX340K1EDE2 — AIR CLEANER ASSY.

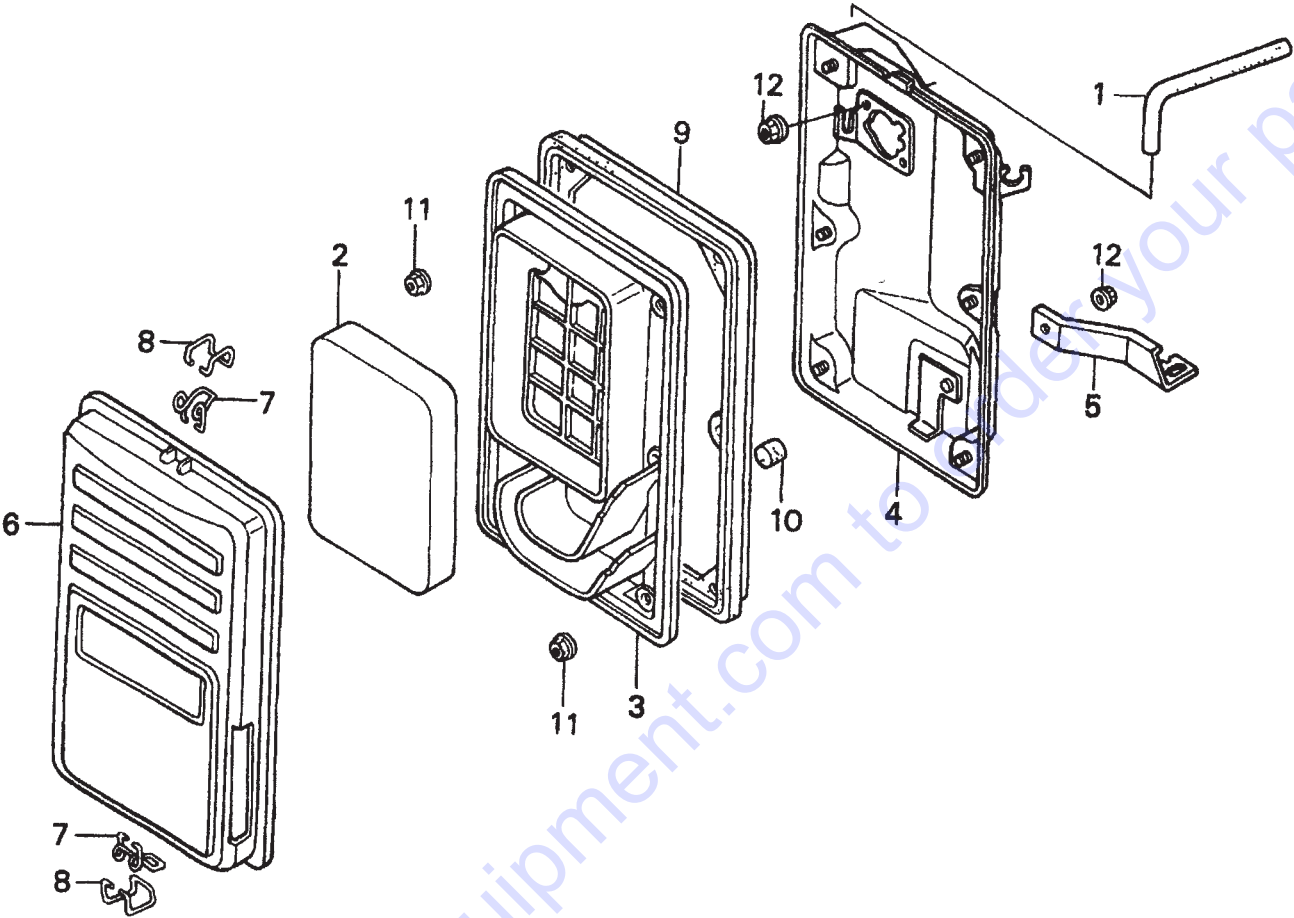

## HONDA GX340K1EDE2 — AIR CLEANER ASSY.

<u>NO.</u>	<u>PART NO.</u>	<u>PART NAME</u>	<u>QTY.</u>	<u>REMARKS</u>
1	15721ZB4000	TUBE BREATHER	1	
2	17211899000	ELEMENT, AIR CLEANER	1	
3	17212ZB4003	SEPARATOR, AIR CLEANER	1	
4	17220ZB4003	HOUSING, AIR CLEANER	1	
5	17222ZC2000	STAY, AIR CLEANER	1	
6	17231899000	COVER, AIR CLEANER	1	
7	17235899000	CLIP A, AIR CLEANER WIRE	2	
8	17236899000	CLIP B, AIR CLEANER WIRE	2	
9	17252899000	SEAL, AIR CLEANER	1	
10	17367413690	FILTER, DRAIN TUBE	1	
11	9405005000	NUT, FLANGE (5MM)	6	
12	9405006000	NUT, FLANGE (6MM)	3	

Go to Discount-Equipment.com to order your parts

# HONDA GX340RT2EDE2 — AIR CLEANER ASSY.

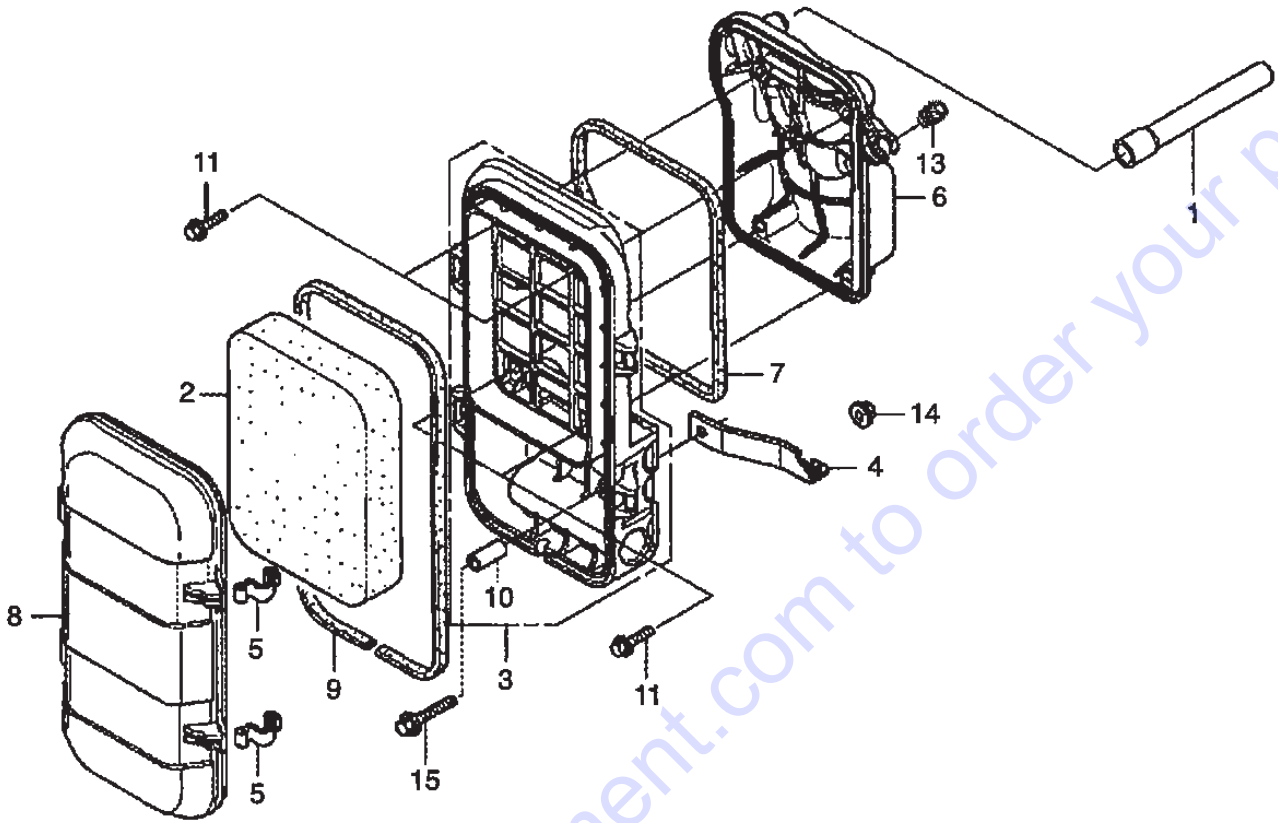



## HONDA GX340RT2EDE2 — AIR CLEANER ASSY.

<u>NO.</u>	<u>PART NO.</u>	<u>PART NAME</u>	<u>QTY.</u>	<u>REMARKS</u>
1	15721Z23H60	TUBE, BREATHER	1	
2	17211899000	ELEMENT, AIR CLEANER	1	
3	17220Z23S30	CASE COMP., AIR CLEANER .....	1.....	INCLUDES ITEM W/\$
4	17222Z23H60	STAY, AIR CLEANER	1	
5	17223Z23000	SPRING, AIR CLEANER CASE LID	2	
6	17223Z23S30	BASE COMP., AIR CLEANER	1	
7	17229Z23H60	SEAL, AIR CLEANER CASE	1	
8	17231Z23H60	COVER, AIR CLEANER	1	
9	17233Z23H60	SEAL, AIR CLEANER COVER	1	
10\$	17238ZE7710	COLLAR, AIR CLEANER	1	
11	90005ZM3000	BOLT, FLANGE. 5X18	4	
13	90854ZB3000	RUBBER, FUEL 9X15X20	1	
14	9405006000	NUT, FLANGE 6MM	1	
15	957010603208	BOLT, FLANGE 6X32	1	

Go to Discount-Equipment.com to order your parts

# HONDA GX340K1EDE2/RT2EDE2 — CAMSHAFT ASSY.

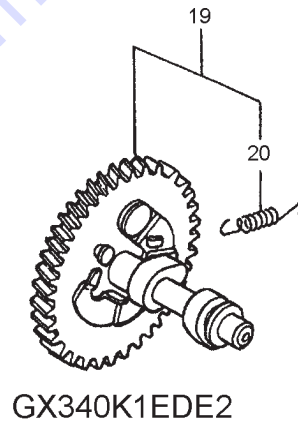
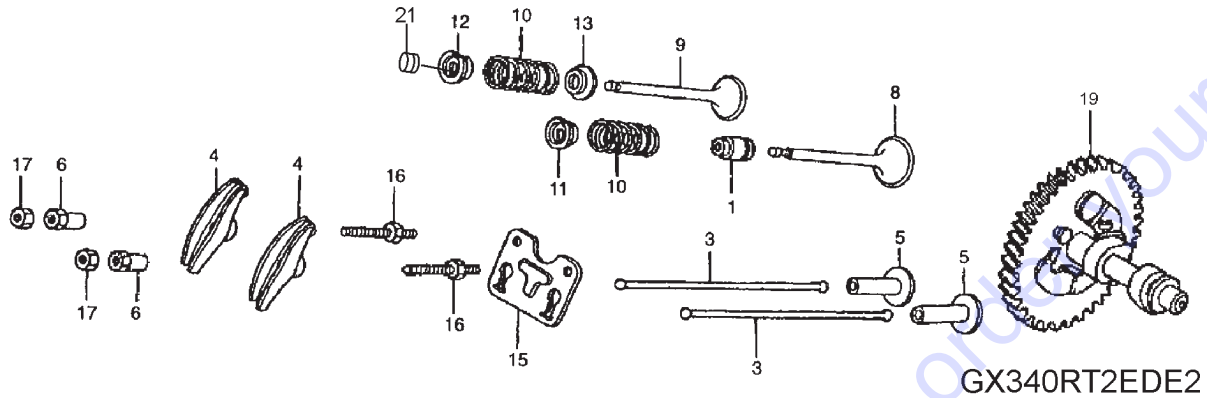

## HONDA GX340K1EDE2/RT2EDE2 — CAMSHAFT ASSY.

<u>NO.</u>	<u>PART NO.</u>	<u>PART NAME</u>	<u>QTY.</u>	<u>REMARKS</u>
1	12209ZE8003	SEAL, VALVE STEM	1	
3	14410ZE3013	ROD, PUSH, (GX340K1EDE2)	2	
3	14410Z1C000	ROD, PUSH, (GX340RT2EDE2)	2	
4	14431ZE2010	ARM, VALVE ROCKER	2	
5	14441ZE2000	LIFTER, VALVE	2	
6	14451ZE1013	PIVOT, ROCKER ARM	2	
8	14711ZE3000	VALVE, IN., (GX340K1EDE2)	1	
8	14711Z5T000	VALVE, IN., (GX340RT2EDE2)	1	
9	14721ZE3000	VALVE, EX., (GX340K1EDE2)	1	
9	14721Z5T000	VALVE, EX.,(GX340RT2EDE2)	1	
10	14751ZE2003	SPRING, VALVE, (GX340K1EDE2)	2	
10	14751Z1C000	SPRING, VALVE, (GX340RT2EDE2)	2	
11	14771ZE2000	RETAINER, IN. VALVE SPRING .....	1	GX340K1EDE2
11	14771Z8S000	RETAINER, IN. VALVE SPRING .....	1	GX340RT2EDE2
12	14773ZE2000	RETAINER, EX. VALVE SPRING .....	1	GX340K1EDE2
12	14771Z8S000	RETAINER, EX. VALVE SPRING .....	1	GX340RT2EDE2
13	14775ZE2010	SEAT, VALVE SPRING	1	
15	14791ZE2010	GUIDE, PUSH ROD, (GX340K1EDE2)	1	
15	14791Z1D000	GUIDE, PUSH ROD, (GX340RT2EDE2)	1	
16	90012ZE0010	BOLT, PIVOT 8MM	2	
17	90206ZE1000	NUT, PIVOT ADJUSTING	2	
19	14100ZE3020	CAMSHAFT COMP., (GX340K1EDE2) .....	1	INCLUDES ITEM W/\$
19	14100Z5K910	CAMSHAFT COMP., (GX340RT2EDE2)	1	
20\$	14568ZE1000	SPRING, WEIGHT RETURN	1	
21	14781ZE2000	ROTATOR, VALVE, (GX340K1EDE2)	1	

# HONDA GX340K1EDE2/RT2EDE2 — CARBURETOR ASSY.

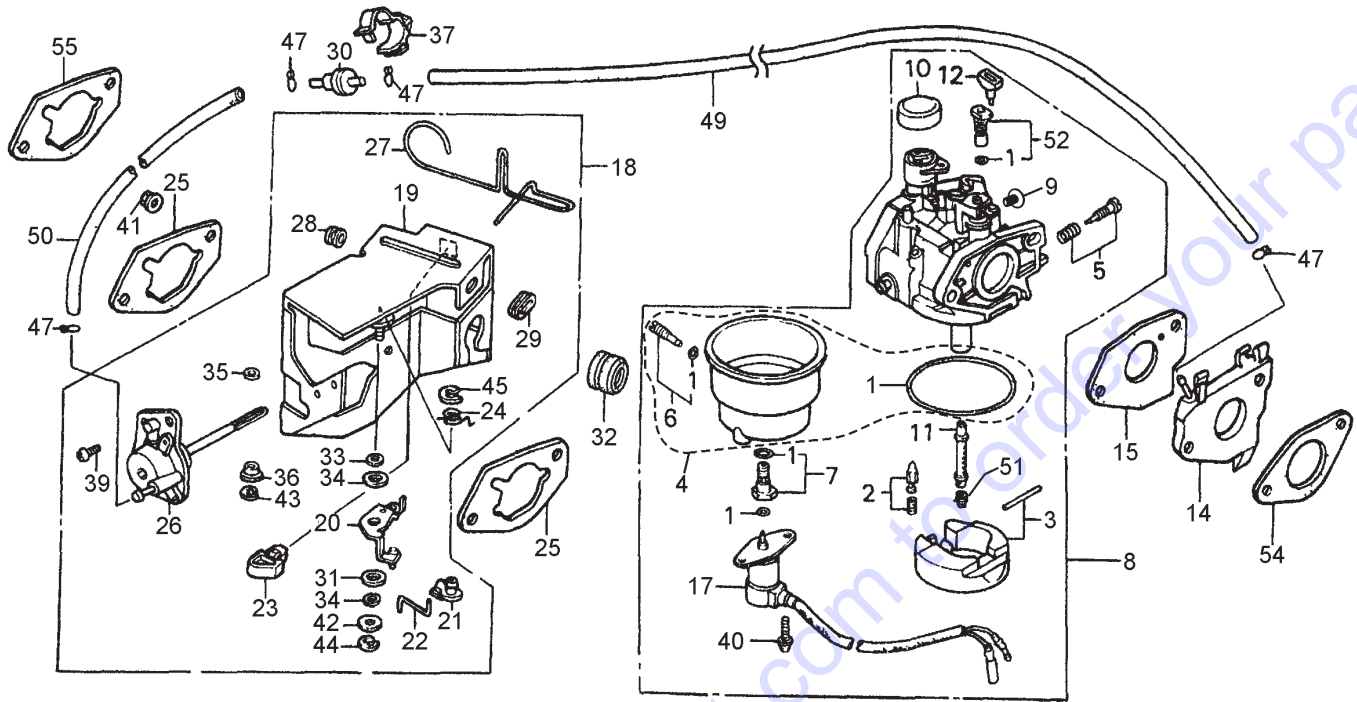

## NOTICE

Gasket Set, item 1 included with items 6, 7, and 52.

# HONDA GX340K1EDE2/RT2EDE2 — CARBURETOR ASSY.

<u>NO.</u>	<u>PART NO.</u>	<u>PART NAME</u>	<u>QTY.</u>	<u>REMARKS</u>
1\$+♦♣@	16010ZE3701	GASKET SET	1	
2\$	16011ZA0931	VALVE SET, FLOAT	1	
3\$	16013ZA0931	FLOAT SET, (GX340K1EDE2)	1	
3\$	16013Z1C003	FLOAT SET, (GX340RT2EDE2)	1	
4\$%	16015ZA0931	CHAMBER SET, FLOAT	1	INCLUDES ITEMS W/@
5\$	16016ZH7W01	SCREW SET	1	
6\$%@	16024124760	SCREW SET, DRAIN	1	INCLUDES ITEMS W/+
7\$%	16028ZA0931	SCREW SET B	1	INCLUDES ITEMS W/♦
8	16100ZE3F12	CARBURETOR ASSY., (BE82B B)	1	INCLUDES ITEMS W/\$
8	16100Z8W702	CARBURETOR ASSY., (BE82V A)	1	INCLUDES ITEMS W/\$ GX340K1EDE2 GX340RT2EDE2
9\$	16124ZE0005	SCREW, THROTTLE STOP	1	
10\$	16148141881	CAP, CHOKE LEVER DUST	1	
11\$	16166ZE3F10	NOZZLE, MAIN	1	
12\$	16172ZE3W10	COLLAR, SETTING	1	
14	16211ZE3700	INSULATOR, CARB., (GX340K1EDE2)	1	
14	16211Z9H700	INSULATOR, CARB., (GX340RT2EDE2)	1	
15	16223ZE3800	GASKET, INSUL., (GX340K1EDE2)	1	
15	16221Z8T000	GASKET, INSUL., (GX340RT2EDE2)	1	
17\$	16230ZE3702	VALVE ASSY., SOLENOID	1	
18	16260ZE2723	STAY ASSY., MANUAL CHOKE	1	INCLUDES ITEMS W/# GX340K1EDE2
18	16260ZE3D22	STAY ASSY., MANUAL CHOKE	1	INCLUDES ITEMS W/◇ GX340RT2EDE2
19#	16261ZE2702	STAY, SOLENOID	1	
20#	16262ZE2711	LEVER, CHOKE	1	
21#	16263ZA0000	JOINT, ROD	1	
22#	16264ZE2701	ROD, CHOKE	1	
23#	16265ZE2721	STOPPER, CHOKE ROD	1	
24#	16268ZE2721	SPRING, MANUAL CHOKE	1	
25	16269ZA0800	GASKET, AIR CLNR., (GX340K1EDE2)	2	
25	17228Z5T000	GASKET, AIR CLNR., (GX340RT2EDE2)	2	
26#	16400ZE2704	DIAPHRAGM ASSY.	1	
27#	16611ZE2711	ROD, CHOKE CTRL. (GX340K1EDE2)	1	
27◇	16611ZE3D21	ROD, CHOKE CTRL. (GX340RT2EDE2)	1	
28#	16613893000	GROMMET, CHOKE ROD	1	
29#	16615893000	GUIDE, CHOKE ROD	1	
30	36135ZF6D41	VALVE, DASHPOT CHECK	1	

# HONDA GX340K1EDE2/RT2EDE2 — CARBURETOR ASSY.

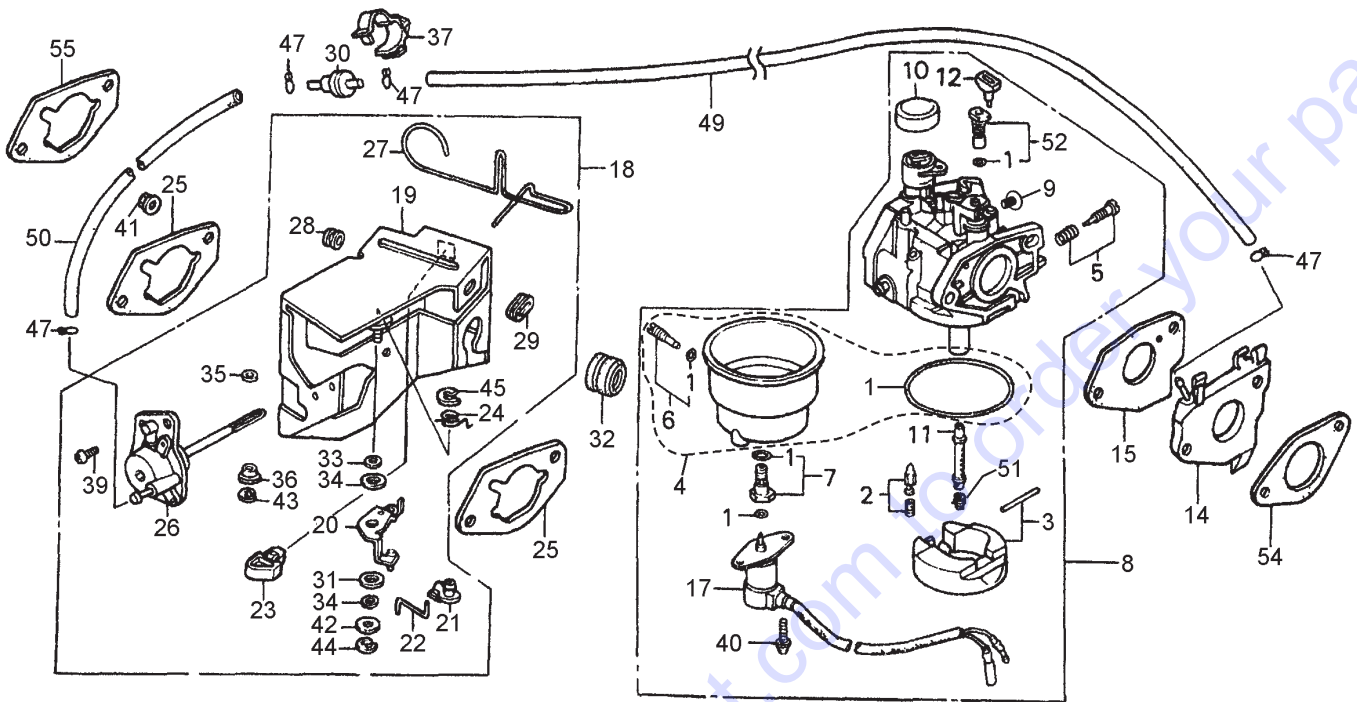

## HONDA GX340K1EDE2/RT2EDE2 — CARBURETOR ASSY.

<u>NO.</u>	<u>PART NO.</u>	<u>PART NAME</u>	<u>QTY.</u>	<u>REMARKS</u>
31#	53149964003	BUSH, ARM PIVOT	1	
32	88911MJ3000	GROMMET, FENDER	1	
33#	90431ZE2700	WASHER, CHOKE LEVER	1	
34#	90432ZE2700	SEAL, CHOKE LEVER	2	
35#	90433ZE2700	WASHER, THRUST (2.7X8)	1	
36#	90434ZE2700	COLLAR, LEVER	1	
37	90650SD9003	CLIP, WIRE HARNESS	1	
39#	93500050120A	SCREW, PAN (5X12)	2	
40\$	938920501208	SCREW, WASHER (5X12)	2	
41	9405006000	NUT, FLANGE (6MM)	2	
42#	9410305000	WASHER, FLAT (5MM)	1	
43#	9454002010	E-RING (2MM)	1	
44#	9454004010	E-RING (4MM)	1	
45#	9454007010	E-RING (7MM)	1	
47	9500202070	CLIP, TUBE (B7)	4	
49	950053507510	TUBE (3.5X75)	1	
50	950053513010	TUBE (3.5X130)	1	
51\$	99101ZH80950	JET, MAIN (#95)	1	
51\$	99101ZH80980	JET, MAIN (#98)	1	
51\$	99101ZH81000	JET, MAIN (#100)	1	
52\$	99204ZE00350	JET, SET PILOT MAIN, (#35)	1	INCLUDES ITEMS W/♣
52\$	99204ZE00380	JET, SET PILOT MAIN, (#38)	1	INCLUDES ITEMS W/♣
54	16212Z5T000	GASKET, CARBURETOR INSULATOR	1	
55	16220ZA0702	SPACER COMP., CARBURETOR	1	

# HONDA GX340K1EDE2/RT2EDE2 — CONTROL ASSY.

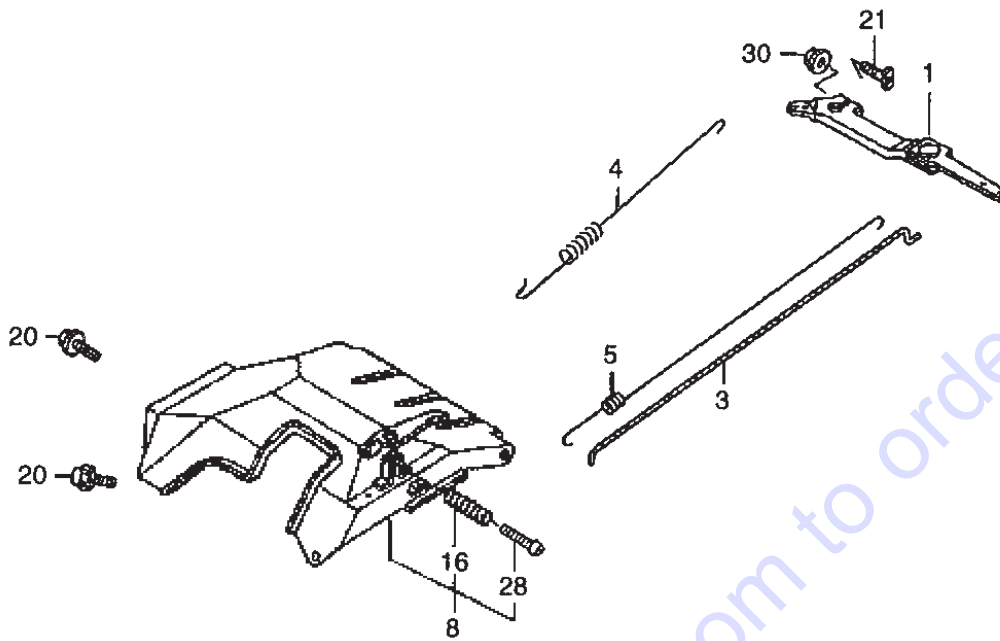

Go to Discount-Equipment.com to order your parts



## HONDA GX340K1EDE2/RT2EDE2 — CONTROL ASSY.

<u>NO.</u>	<u>PART NO.</u>	<u>PART NAME</u>	<u>QTY.</u>	<u>REMARKS</u>
1	16550ZE3700	ARM COMP., GOVERNOR	1	
3	16555ZE3000	ROD, GOVERNOR	1	
4	16561ZE3000	SPRING, GOVERNOR, (GX340K1EDE2)	1	
4	16561ZK6D70	SPRING, GOVERNOR, (GX340RT2EDE2)	1	
5	16562ZE3700	SPRING, THROTTLE RETURN	1	
8	16570ZE3700	CONTROL ASSY., (GX340K1EDE2) .....	1	INCLUDES ITEMS W/%
8	16500Z5T880	CONTROL ASSY., (GX340RT2EDE2) .....	1	INCLUDES ITEMS W/%
16%	16584883300	SPRING, CONTROL ADJUSTING	1	
20	90013883000	BOLT, FLANGE 6X12	2	
21	90015ZE5010	BOLT, GOVERNOR ARM, (GX340K1EDE2)	1	
21	90015Z5T000	BOLT, GOVERNOR ARM, (GX340RT2EDE2)	1	
28%	93500050350A	SCREW, PAN 5X35	1	
30	9405006000	NUT, FLANGE 6MM	1	

Go to Discount-Equipment.com to order your parts

# HONDA GX340K1EDE2/RT2EDE2 — CRANKCASE CVR. ASSY.

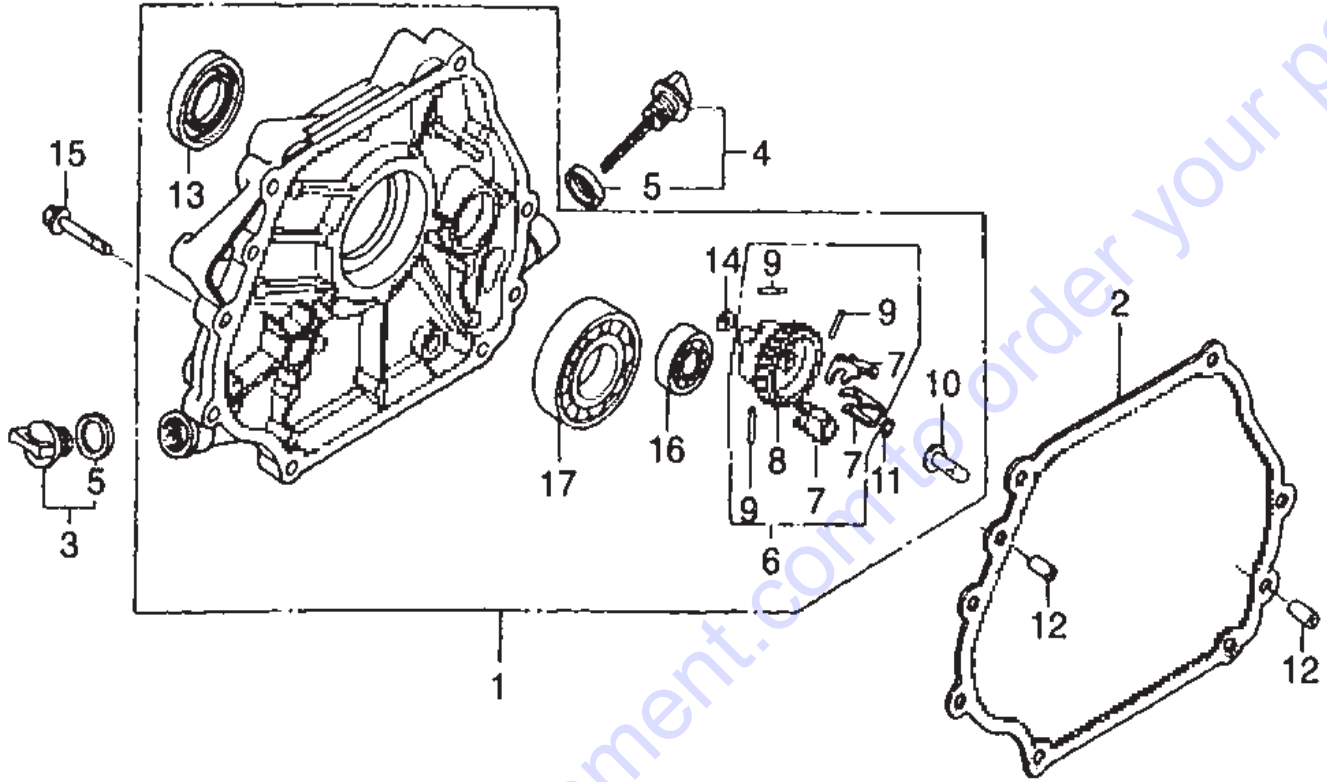

# HONDA GX340K1EDE2/RT2EDE2 — CRANKCASE CVR. ASSY.

NO.	PART NO.	PART NAME	QTY.	REMARKS
1	11300ZE3020	COVER ASSY., CRANKCASE .....	1.....	INCLUDES ITEMS W/% GX340K1EDE2
1	11300Z1C000	COVER ASSY., CRANKCASE .....	1.....	INCLUDES ITEMS W/\$ GX340RT2EDE2
2	11381ZE3801	GASKET, CASE COVER, (GX340K1EDE2)	1	
2	11381Z5T000	GASKET, CASE COVER, (GX340RT2EDE2)	1	
3	15600ZG4003	CAP ASSY., OIL FILTER, (GX340K1EDE2) .....	1.....	INCLUDES ITEM W/@
3	15600Z0T820	CAP ASSY., OIL FILTER, (GX340RT2EDE2) ....	1.....	INCLUDES ITEM W/◇
4	15600735003	CAP ASSY., OIL FILTER, (GX340K1EDE2) .....	1.....	INCLUDES ITEM W/+
4	15600Z1C000	CAP ASSY., OIL FILTER, (GX340RT2EDE2) ....	1.....	INCLUDES ITEM W/◆
5@+	15625ZE1003	GASKET, OIL FILTER CAP, (GX340K1EDE2)	2	
5◇◆	15625Z0T800	GASKET, OIL FILTER CAP, (GX340RT2EDE2)	2	
6	16510ZE3000	GOVERNOR ASSY. ....	1.....	INCLUDES ITEMS W/#
7%\$#	16511ZE8000	WEIGHT, GOVERNOR	3	
8%\$#	16512ZE3000	HOLDER, GOVERNOR WEIGHT	1	
9%\$#	16513ZE2000	PIN, GOVERNOR WEIGHT	3	
10%	16531ZE2000	SLIDER, GOVERNOR, (GX340K1EDE2)	1	
10\$	16531Z0A000	SLIDER, GOVERNOR, (GX340RT2EDE2)	1	
11%	90602ZE1000	CLIP, GOVERNOR HOLDER	1	
12	90701HC4000	DOWEL PIN 8x12	2	
13%\$	91201Z1C003	OIL SEAL 35x52x8	1	
14%\$	9410106800	WASHER, FLAT 6MM	1	
15	957010804000	BOLT, FLANGE 8x40	7	
16%\$	961006202000	BEARING, RADIAL BALL 6202	1	
17%\$	961006207000	BEARING, RADIAL BALL 6207	1	

# HONDA GX340K1EDE2/RT2EDE2 — CRANKSHAFT ASSY.

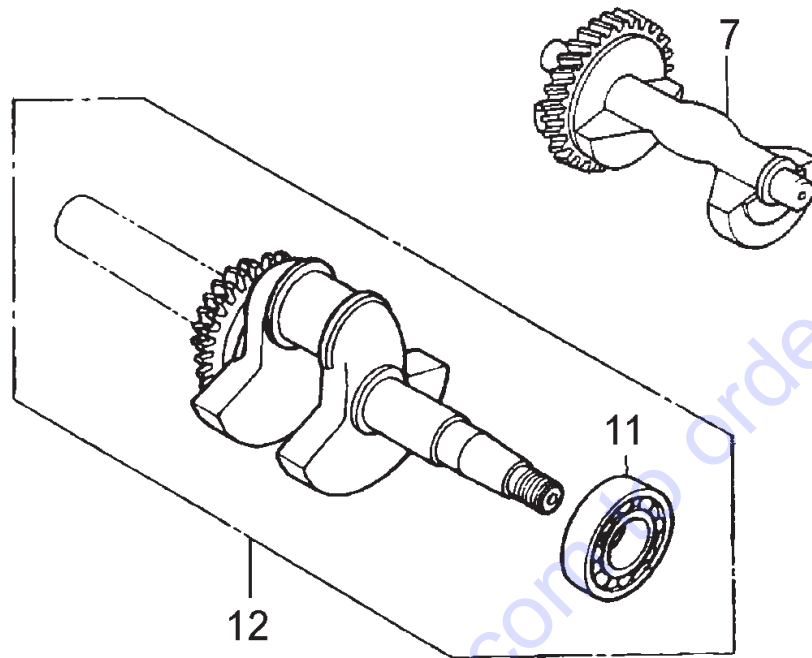

Go to Discount-Equipment.com to order your parts

## HONDA GX340K1EDE2/RT2EDE2 — CRANKSHAFT ASSY.

<u>NO.</u>	<u>PART NO.</u>	<u>PART NAME</u>	<u>QTY.</u>	<u>REMARKS</u>
7	13351ZE3010	WEIGHT, BALANCER	1	
11\$	961006207000	BEARING, RADIAL BALL, (GX340K1EDE2)	1	
11%	91001ZF6013	BEARING, RADIAL BALL, (GX340RT2EDE2)	1	
12	13310ZE3701	CRANKSHAFT COMP., (GX340K1EDE2) .....	1.....	INCLUDES ITEMS W/\$
12	13310ZF6D42	CRANKSHAFT COMP., (GX340RT2EDE2) .....	1.....	INCLUDES ITEMS W/%

Go to Discount-Equipment.com to order your parts

# HONDA GX340K1EDE2/RT2EDE2 — CYL. BARREL ASSY.

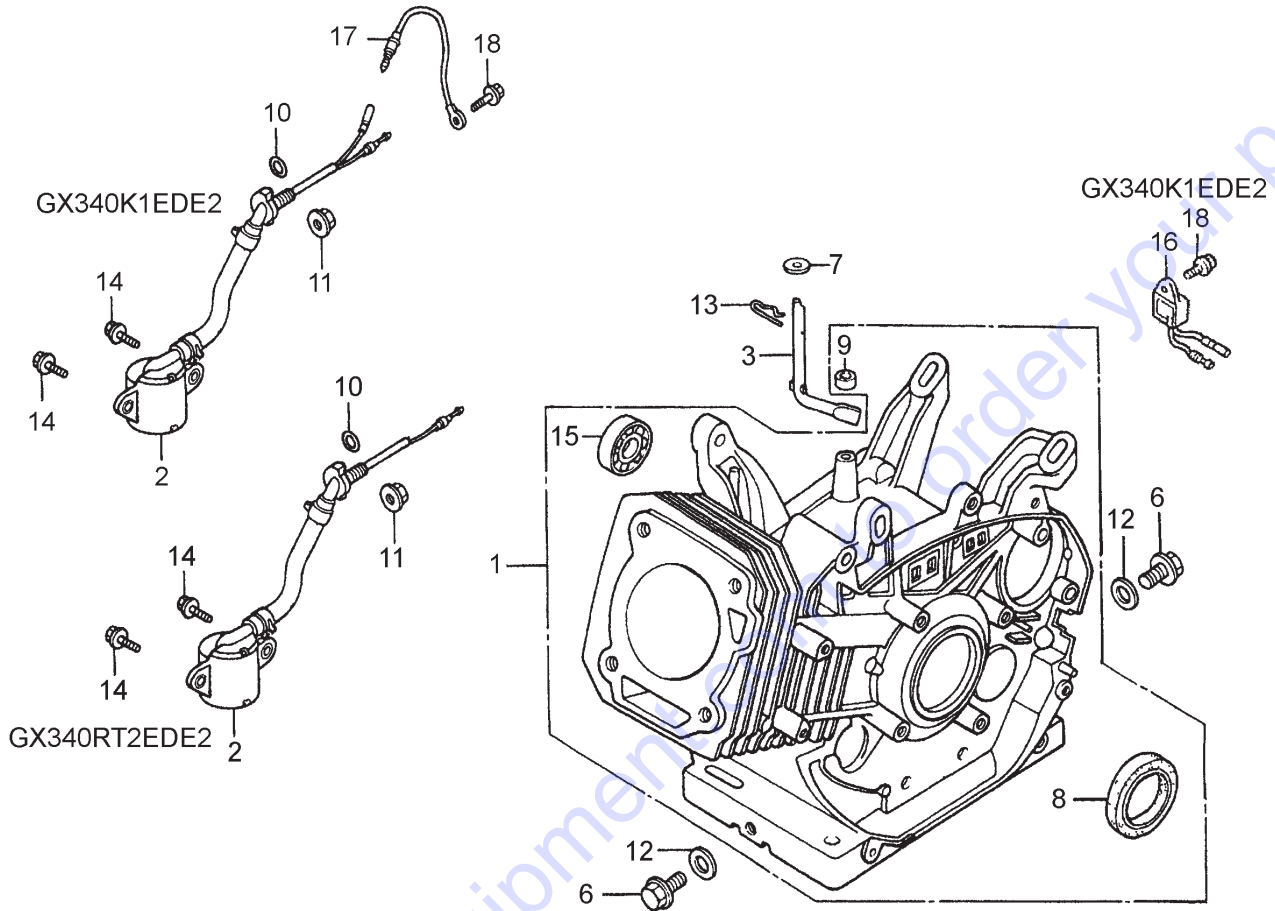

## HONDA GX340K1EDE2/RT2EDE2 — CYL. BARREL ASSY.

NO.	PART NO.	PART NAME	QTY.	REMARKS
1	12000ZE3827	BARREL ASSY., CYL., (GX340K1EDE2).....	1.....	INCLUDES ITEMS W/#
1	12000Z5T405	BARREL ASSY., CYL., (GX340RT2EDE2) .....	1.....	INCLUDES ITEMS W/%
2	15510ZE2043	SWITCH ASSY., OIL ALERT .....	1.....	GX340K1EDE2
2	35480ZF6003	SWITCH ASSY., OIL ALERT .....	1.....	GX340RT2EDE2
3	16541ZE3010	SHAFT, GOVERNOR ARM	1	
6	90131883000	BOLT, DRAIN PLUG 12X15	2	
7	90446KE1000	WASHER, 8.2X17X0.8	1	
8#	91201ZE3004	OIL SEAL, 35X52X8, (GX340K1EDE2)	1	
8%	91201Z1C003	OIL SEAL, 35X52X8, (GX340RT2EDE2)	1	
9#%	91203952771	OIL SEAL, 8X14X5	1	
10	91353671004	O-RING, 14MM (NOK)	1	
11	9405010000	NUT FLANGE, 10MM	1	
12	9410912000	WASHER, DRAIN PLUG 12MM	2	
13	9425110000	PIN, LOCK 10MM	1	
14	957010601200	BOLT, FLANGE 6X12	2	
15#%	961006202000	BEARING, RADIAL BALL 6202	1	
16	34150ZH7003	ALERT UNIT, OIL, (GX340K1EDE2)	1	
17	31161ZE2000	CORD, EARTH, (GX340K1EDE2)	1	
18	90013883000	BOLT, FLANGE 6X12 , (GX340K1EDE2)	2	

Go to Discount-Equipment.com to order your parts

# HONDA GX340K1EDE2/RT2EDE2 — CYLINDER HEAD ASSY.

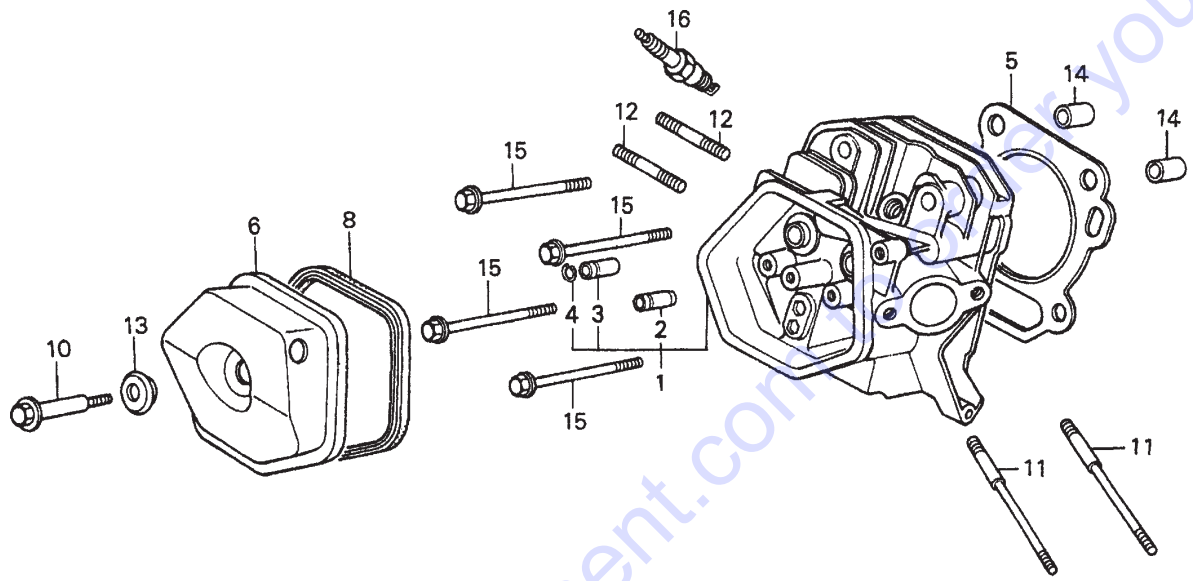



## HONDA GX340K1EDE2/RT2EDE2 — CYLINDER HEAD ASSY.

NO.	PART NO.	PART NAME	QTY.	REMARKS
1	12200ZF6W01	HEAD COMP., CYLINDER, (GX340K1EDE2)....	1	INCLUDES ITEMS W/#
1	12210Z5T406	HEAD COMP., CYLINDER, (GX340RT2EDE2)..	1	INCLUDES ITEMS W/#
2#	12204ZE2306	GUIDE, IN. VALVE (OVER SIZE)	1	
3#	12205ZE2305	GUIDE, EX. VALVE (OVER SIZE)	1	
4#	12216ZE2300	CLIP, VALVE GUIDE	1	
5	12251ZE3W00	GASKET, CYL. HEAD .....	1	GX340K1EDE2
5	12251Z5T003	GASKET, CYL. HEAD .....	1	GX340RT2EDE2
6	12310ZE2020	COVER, CYLINDER HEAD	1	
8	12391ZE2020	PACKING, HEAD COVER	1	
10	90014ZE2000	BOLT, HEAD COVER, (GX340K1EDE2)	1	
10	90014Z5T000	BOLT, HEAD COVER, (GX340RT2EDE2)	1	
11	90042ZE3700	BOLT, STUD 8X106, (GX340K1EDE2)	2	
11	90042ZK6D70	BOLT, STUD 8X115, (GX340RT2EDE2)	2	
12	92900080320E	BOLT, STUD 8X32	2	
13	90441ZE2010	WASHER COMP., HEAD COVER	1	
14	9430112200	DOWEL PIN 12X20	2	
15	957011008000	BOLT, FLANGE 10X80	4	
16	9807955846	PLUG, SPARK (BPR5ES NGK) .....	1	GX340K1EDE2
16	9807955876	PLUG, SPARK (BPR5ES NGK) .....	1	GX340RT2EDE2
16	9807955855	PLUG, SPARK (W16EPR-U DENSO)	1	

**HONDA GX340K1EDE2/RT2EDE2 — FAN COVER ASSY.**

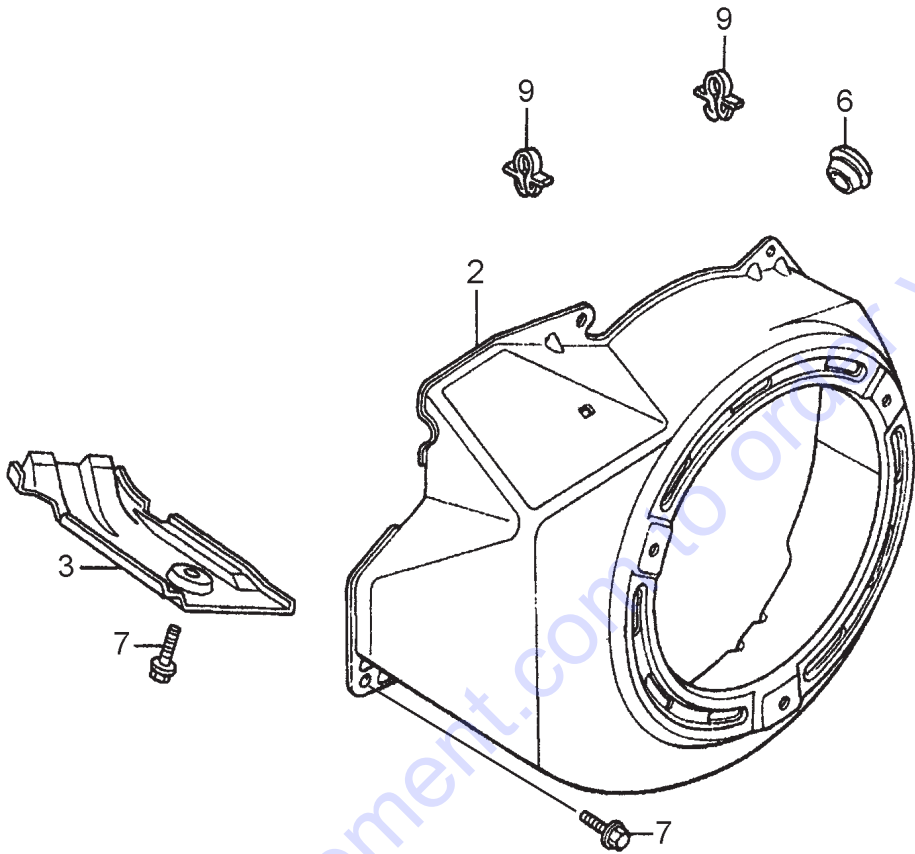

Go to Discount-Equipment.com to order your parts

## HONDA GX340K1EDE2/RT2EDE2 — FAN COVER ASSY.

<u>NO.</u>	<u>PART NO.</u>	<u>PART NAME</u>	<u>QTY.</u>	<u>REMARKS</u>
2	19610ZE3700ZB	COVER, FAN *NH1*, BLK (GX340K1EDE2)	1	
2	19610Z5T800ZC	COVER, FAN *NH1*, BLK (GX340RT2EDE2)	1	
3	19631ZE3W00	SHROUD, (GX340K1EDE2)	1	
3	19631Z5T000	SHROUD, (GX340RT2EDE2)	1	
6	81329567020	GROMMET, DRAIN HOLE	1	
7	90013883000	BOLT, FLANGE 6X12	6	
9	90654SA4003	CLIP, WIRE HARNESS 6MM (WHITE)	2	

Go to Discount-Equipment.com to order your parts

# HONDA GX340K1EDE2/RT2EDE2 — FLYWHEEL ASSY.

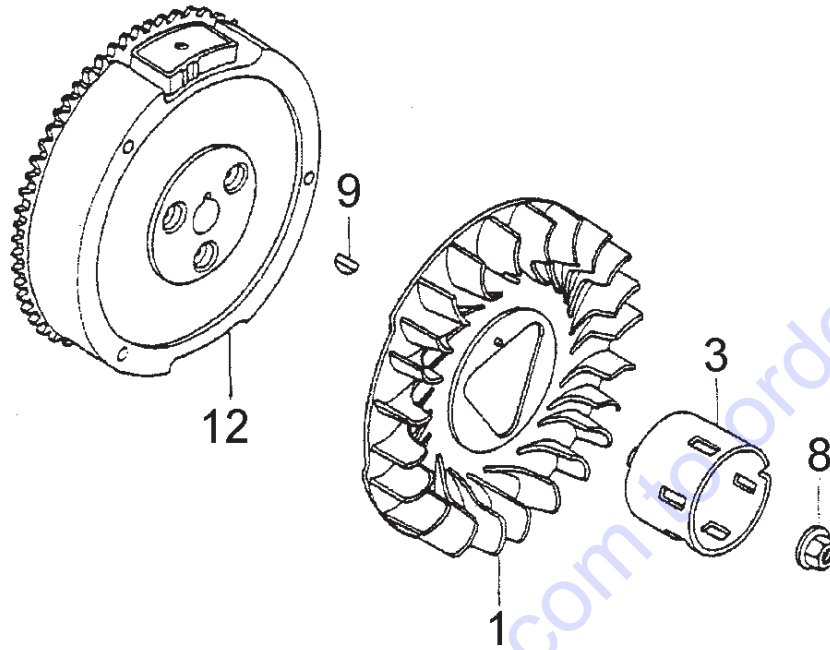

## HONDA GX340K1EDE2/RT2EDE2 — FLYWHEEL ASSY.

<u>NO.</u>	<u>PART NO.</u>	<u>PART NAME</u>	<u>QTY.</u>	<u>REMARKS</u>
1	19511ZE3000	FAN, COOLING	1	
3	28451ZE3W01	PULLEY, STARTER	1	
8	90201ZE3V00	NUT, SPECIAL 16MM	1	
9	90741ZE2000	KEY, SPECIAL WOODRUFF 25X18	1	
12	31100ZE3722	FLYWHEEL COMP., (GX340K1EDE2)	1	
12	31100Z5T820	FLYWHEEL COMP., (GX340RT2EDE2)	1	

Go to Discount-Equipment.com to order your parts

# HONDA GX340K1EDE2/RT2EDE2 — IGNITION COIL ASSY.

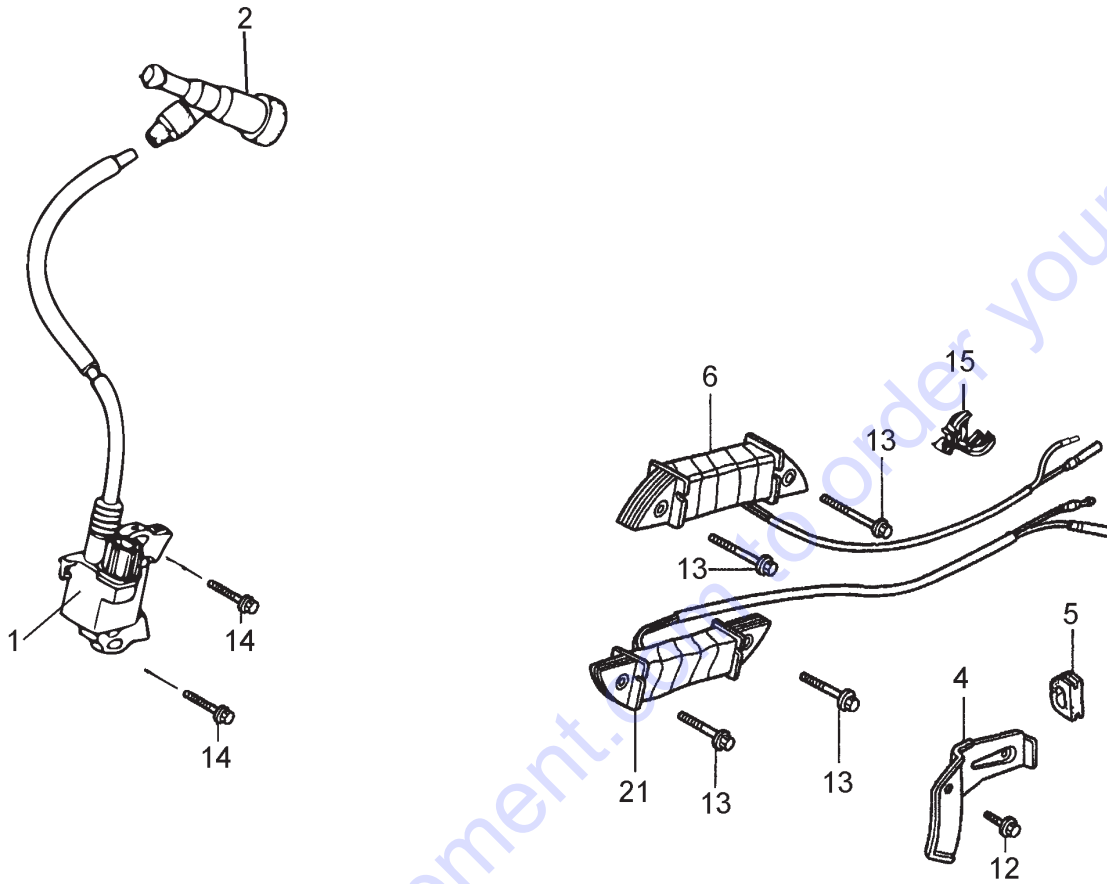

## HONDA GX340K1EDE2/RT2EDE2 — IGNITION COIL ASSY.

<u>NO.</u>	<u>PART NO.</u>	<u>PART NAME</u>	<u>QTY.</u>	<u>REMARKS</u>
1	30500ZE2023	COIL ASSY., IGNITION, (GX340K1EDE2)	1	
1	30500Z5T003	COIL ASSY., IGNITION, (GX340RT2EDE2)	1	
2	30700ZE1013	CAP ASSY., NOISE SUPP., (GX340K1EDE2)	1	
2	30700Z1C811	CAP ASSY., NOISE SUPP., (GX340RT2EDE2)	1	
4	31511ZE3000	CLAMPER, CORD	1	
5	31512ZE2000	GROMMET, CORD	1	
6	31510ZE1811	COIL ASSY., LAMP 12V, 25W	1	
12	90013883000	BOLT, FLANGE 6X12	1	
13	90012888000	BOLT, FLANGE 6X40	4	
14	90015883000	BOLT, FLANGE 6X28	2	
15	36103ZE1000	HOLDER, STOP SW CORD, (GX340K1EDE2)	1	
15	90684ZA0601	CLIP HARNESS, (GX340RT2EDE2)	1	
21	31510ZE3003	COIL ASSY., LAMP 12V, 25W	1	

Go to Discount-Equipment.com to order your parts

# HONDA GX340K1EDE2/RT2EDE2 — PISTON ASSY.

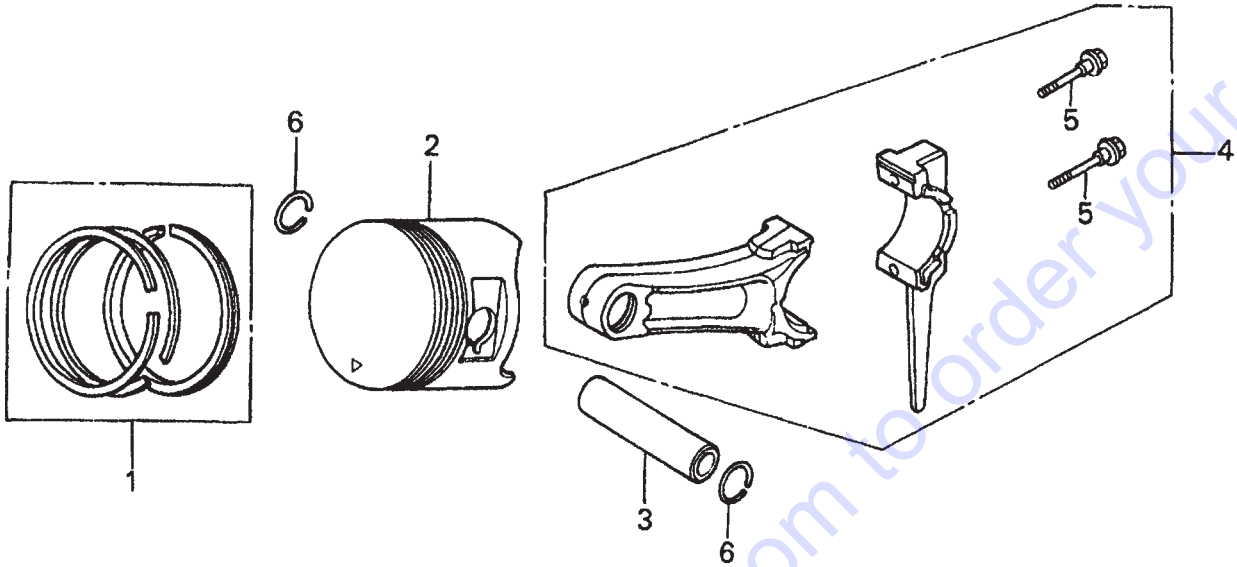



## HONDA GX340K1EDE2/RT2EDE2 — PISTON ASSY.

NO.	PART NO.	PART NAME	QTY.	REMARKS
1	13010ZE3003	RING SET, PISTON (STD), (GX340K1EDE2)	1	
1	13010Z5R004	RING SET, PISTON (STD), (GX340RT2EDE2)	1	
1	13011ZE3003	RING SET, PISTON (0.25), (GX340K1EDE2)	1	
1	13011Z5R004	RING SET, PISTON (0.25), (GX340RT2EDE2)	1	
1	13012ZE3003	RING SET, PISTON (0.50), (GX340K1EDE2)	1	
1	13012Z5R004	RING SET, PISTON (0.50), (GX340RT2EDE2)	1	
1	13013ZE3003	RING SET, PISTON (0.75), (GX340K1EDE2)	1	
1	13013Z5R004	RING SET, PISTON (0.75), (GX340RT2EDE2)	1	
2	13101ZE3W00	PISTON (STD), (GX340K1EDE2)	1	
2	13101Z5T800	PISTON (STD), (GX340RT2EDE2)	1	
2	13102ZE3W00	PISTON (0.25), (GX340K1EDE2)	1	
2	13102Z5T800	PISTON (0.25), (GX340RT2EDE2)	1	
2	13103ZE3W00	PISTON (0.50), (GX340K1EDE2)	1	
2	13103Z5T800	PISTON (0.50), (GX340RT2EDE2)	1	
2	13104ZE3W00	PISTON (0.75), (GX340K1EDE2)	1	
2	13104Z5T800	PISTON (0.75), (GX340RT2EDE2)	1	
3	13111ZF6000	PIN, PISTON, (GX340K1EDE2)	1	
3	13111Z5T000	PIN, PISTON, (GX340RT2EDE2)	1	
4	13200ZE3020	ROD ASSY., CONNEC. (STD) .....	1	INCLUDES ITEMS W/\$ GX340K1EDE2
4	13200Z1C000	ROD ASSY., CONNEC. (STD) .....	1	INCLUDES ITEMS W/\$ GX340RT2EDE2
4	13200ZE3315	ROD ASSY., CONNEC. (0.25 UNDER SZ.) .....	1	INCLUDES ITEMS W/% GX340K1EDE2
4	13200Z1C305	ROD ASSY., CONNEC. (0.25 UNDER SZ.) .....	1	INCLUDES ITEMS W/% GX340RT2EDE2
5\$%	90001ZE8000	BOLT, CONNECTING ROD	2	
6	90601ZE3000	CLIP, PISTON PIN 20MM	2	

# HONDA GX340K1EDE2/RT2EDE2 — RECOIL STARTER ASSY.

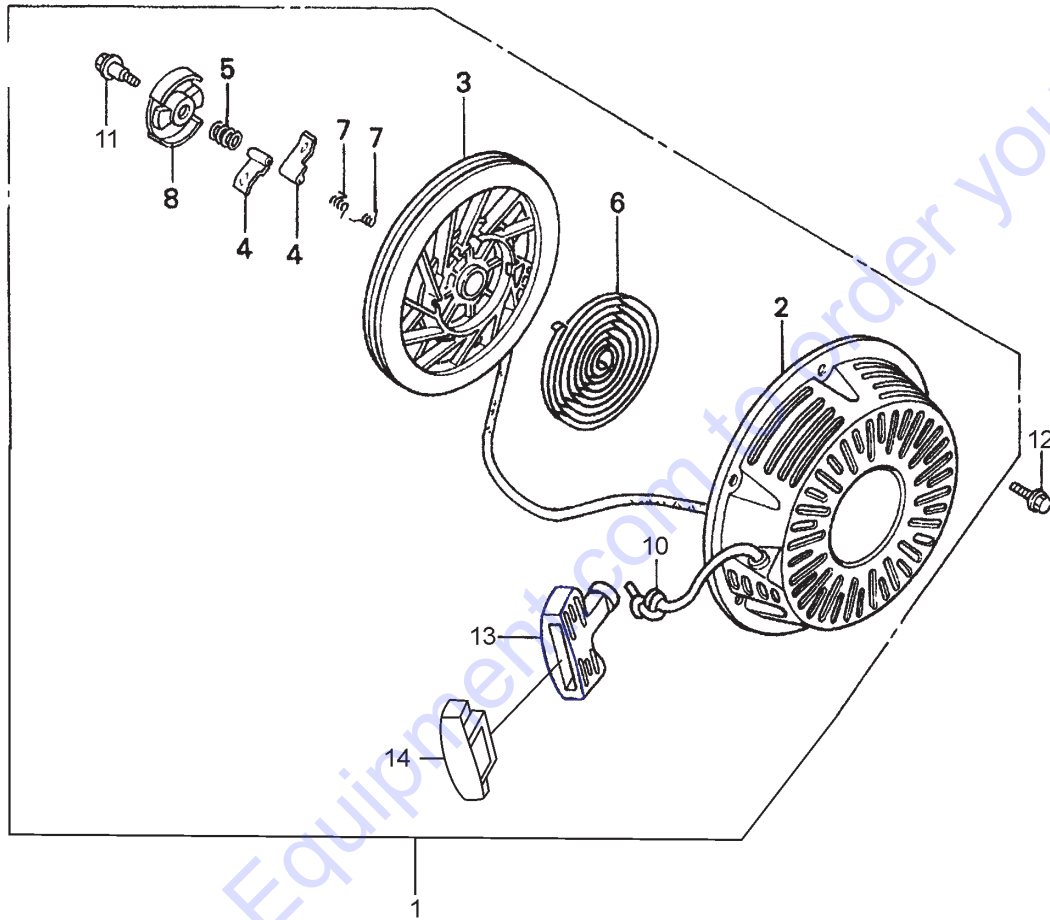

## HONDA GX340K1EDE2/RT2EDE2 — RECOIL STARTER ASSY.

<u>NO.</u>	<u>PART NO.</u>	<u>PART NAME</u>	<u>QTY.</u>	<u>REMARKS</u>
1	28400ZE3W01ZB	STARTER ASSY., RECOIL *NH1*	1	INCLUDES ITEMS W/% GX340K1EDE2
1	28400Z5T013ZB	STARTER ASSY., RECOIL *NH1*	1	INCLUDES ITEMS W/\$ GX340RT2EDE2
2%\$	28410ZE3W01ZB	CASE COMP., RECOIL STARTER *NH1*	1	
3%\$	28421ZE3W01	PULLEY, RECOIL STARTER	1	
4%\$	28422ZE2W01	RATCHET, STARTER	2	
5%\$	28441ZE2W01	SPRING, FRICTION	1	
6%\$	28442ZE2W01	SPRING, STARTER RETURN	1	
7%\$	28443ZE2W01	SPRING, RATCHET	2	
8%\$	28444ZE2W01	RETAINER, SPRING	1	
10%\$	28462ZV7003	ROPE, RECOIL STARTER	1	REPLACES P/N 28462ZE3W01
11%\$	90004ZE2W01	SCREW, CENTER	1	
12	90008ZE2003	BOLT, FLANGE 6X10	3	
13%	28461ZE2W02	GRIP, STARTER, (GX340K1EDE2)	1	
13\$	28461Z5T003	GRIP, STARTER, (GX340RT2EDE2)	1	
14%\$	28463Z5T013	GRIP, REINFORCEMENT	1	

Go to Discount-Equipment.com to order your parts

# HONDA GX340K1EDE2/RT2EDE2 — STARTER MOTOR ASSY.

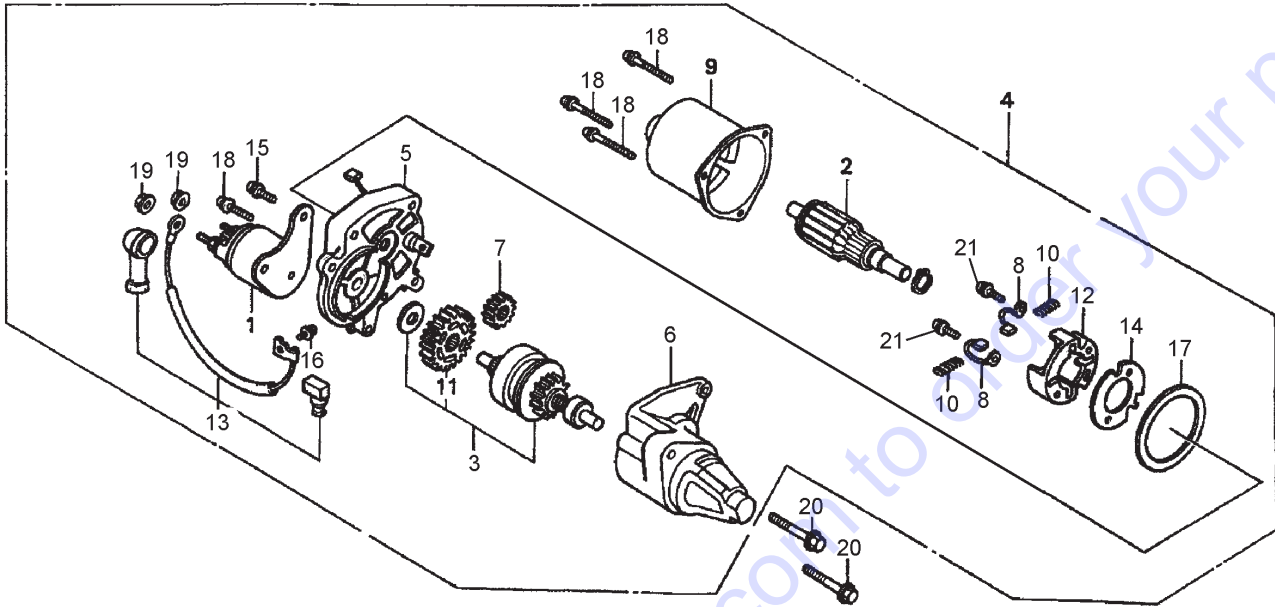

## HONDA GX340K1EDE2/RT2EDE2 — STARTER MOTOR ASSY.

<u>NO.</u>	<u>PART NO.</u>	<u>PART NAME</u>	<u>QTY.</u>	<u>REMARKS</u>
1\$	31204ZA0003	CONTACTOR ASSY.	1	
2\$	31206ZE3003	ARMATURE COMP	1	
3\$	31207ZE3003	CLUTCH COMP., OVERRUNNING .....	1.....	INCLUDES ITEMS W/%
4	31210ZE3023	MOTOR UNIT, STARTER .....	1.....	INCLUDES ITEMS W/\$
5\$	31211ZE2003	BRACKET, CENTER	1	
6\$	31212ZE3003	BRACKET, FR.	1	
7\$	31213ZE2003	GEAR, DRIVE PINION	1	
8\$	31215ZE2003	BRUSH	2	
9\$	31218ZE3003	YOKE COMP	1	
10\$	31219ZE2003	SPRING, BRUSH RETURN	4	
11\$%	31222ZE3791	GEAR, REDUCTION	1	
12\$	31231ZE2003	HOLDER, BRUSH	1	
13\$	31232ZE3003	WIRE, WATER COVER	1	
14\$	31233ZE2003	INSULATOR	1	
15\$	90007ZE2003	BOLT, WASHER 5X14	2	
16\$	90110ZE2003	SCREW, WASHER 4X6	1	
17\$	91601ZE2003	PACKING	1	
18\$	938920503218	SCREW, WASHER 5X32	4	
19\$	9407006080	NUT, WASHER 6MM	2	
20	957010803508	BOLT, FLANGE 8X35	2	
21\$	31219ZE3003	SCREW, WASHER 4X14	2	

# HONDA GX340K1EDE2/RT2EDE2 — SOLENOID ASSY.

---

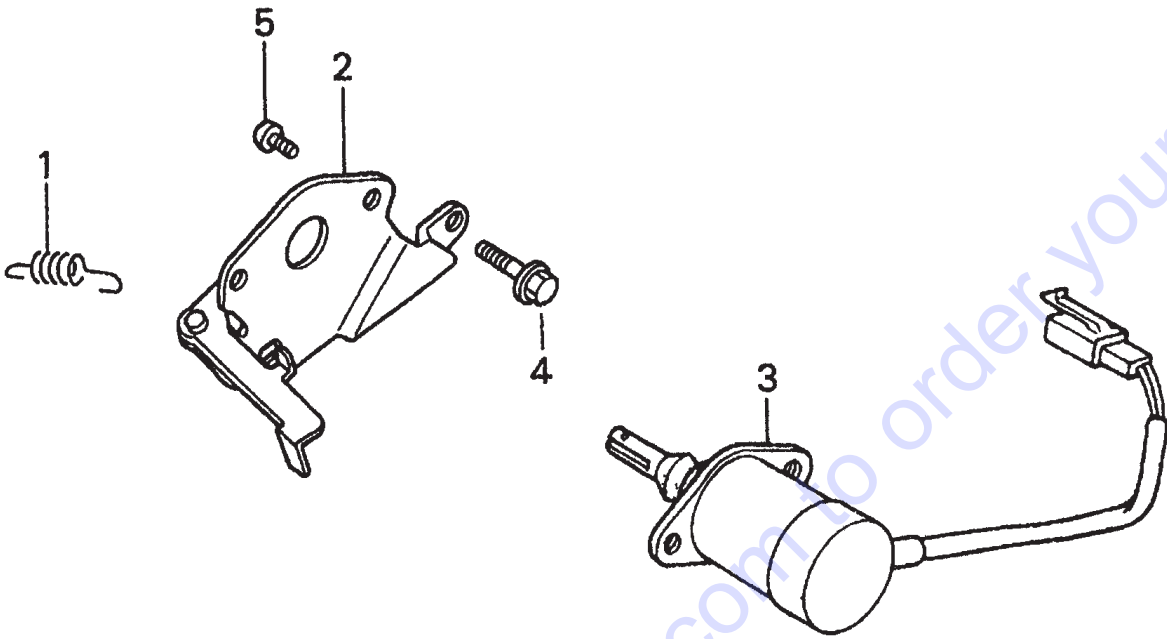

Go to Discount-Equipment.com to order your parts

## HONDA GX340K1EDE2/RT2EDE2 — SOLENOID ASSY.

<u>NO.</u>	<u>PART NO.</u>	<u>PART NAME</u>	<u>QTY.</u>	<u>REMARKS</u>
1	16268893000	SPRING, CHOKE RETURN	1	
2	17850ZD1E30	LEVER COMP., THROTTLE	1	
3	36160ZB4013	SOLENOID ASSY.	1	
4	90013883000	BOLT, FLANGE 6X12	1	
5	93500050080A	SCREW, PAN 5X8	2	

Go to Discount-Equipment.com to order your parts

# HONDA GX340K1EDE2/RT2EDE2 — ENGINE DECALS ASSY.

---

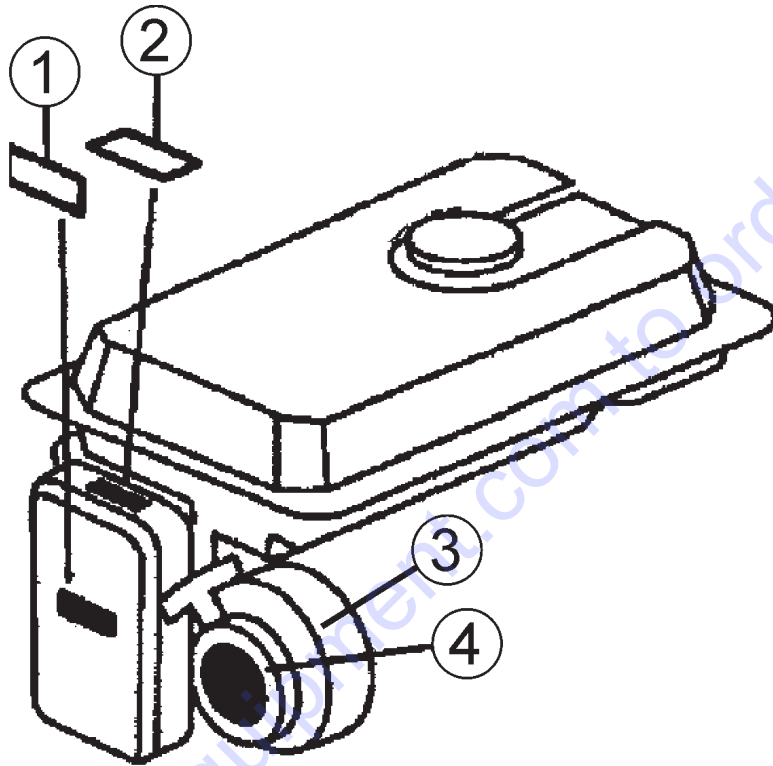



## HONDA GX340K1EDE2/RT2EDE2 — ENGINE DECALS ASSY.

<u>NO.</u>	<u>PART NO.</u>	<u>PART NAME</u>	<u>QTY.</u>	<u>REMARKS</u>
1	87533ZC0630	DECAL: AIR CLEANER (ENGLISH)	1	
2	87528898620	DECAL: CHOKE	1	
3	87594ZB4A00	DECAL: OIL CAUTION	1	
4	87521ZE2W02	EMBLEM, GX340, (GX340K1EDE2)	1	
4	87521Z8T000	EMBLEM, GX340, (GX340RT2EDE2)	1	

Go to Discount-Equipment.com to order your parts

# PARTS FINDER

**Search Website  
by Part Number**



**Search Manual  
Library For Parts  
Manual & Lookup Part  
Numbers – Purchase  
or Request Quote**

**Search Manuals**

Enter your information to help us find the right parts manual for your machine.

\* Brand:

\* Model:

\* Serial:

\* Part Number:

SEARCH

**Can't Find Part or  
Manual? Request Help  
by Manufacturer,  
Model & Description**

**Parts Order Form**

Please fill in the following information to help us find the right part for your machine.

Manufacturer:	<input type="text"/>
Model:	<input type="text"/>
Description:	<input type="text"/>
Part Number:	<input type="text"/>
Quantity:	<input type="text"/>
Notes:	<input type="text"/>

Discount-Equipment.com is your online resource for quality parts & equipment.

Florida: **561-964-4949** Outside Florida TOLL FREE: **877-690-3101**

**Need parts?**

Click on this link: <http://www.discount-equipment.com/category/5443-parts/> and choose one of the options to help get the right parts and equipment you are looking for. Please have the machine model and serial number available in order to help us get you the correct parts. If you don't find the part on the website or on one of the online manuals, please fill out the request form and one of our experienced staff members will get back to you with a quote for the right part that your machine needs.

We sell worldwide for the brands: Genie, Terex, JLG, MultiQuip, Mikasa, Essick, Whiteman, Mayco, Toro Stone, Diamond Products, Generac Magnum, Airman, Haulotte, Barreto, Power Blanket, Nifty Lift, Atlas Copco, Chicago Pneumatic, Allmand, Miller Curber, Skyjack, Lull, Skytrak, Tsurumi, Husquvarna Target, Stow, Wacker, Sakai, Mi-T-M, Sullair, Basic, Dynapac, MBW, Weber, Bartell, Bennar Newman, Haulotte, Ditch Runner, Menegotti, Morrison, Contec, Buddy, Crown, Edco, Wyco, Bomag, Laymor, EZ Trench, Bil-Jax, F.S. Curtis, Gehl Pavers, Heli, Honda, ICS/PowerGrit, IHI, Partner, Imer, Clipper, MMD, Koshin, Rice, CH&E, General Equipment, Amida, Coleman, NAC, Gradall, Square Shooter, Kent, Stanley, Tamco, Toku, Hatz, Kohler, Robin, Wisconsin, Northrock, Oztec, Toker TK, Rol-Air, APT, Wylie, Ingersoll Rand / Doosan, Innovatech, Con X, Ammann, Mecalac, Makinex, Smith Surface Prep, Small Line, Wanco, Yanmar