



**Count on it.**

**Parts Catalog**

**TRX-26 Trencher**

Model No. 22974—Serial No. 313000001 and Up



# Ordering Replacement Parts

To order replacement parts, please supply the part number, the quantity, and the description of each part desired.

## Understanding Reference Numbers

Each identified part in an illustration has a reference number. The reference number for a part also appears in the parts list, along with other information about the part.

This catalog uses two special reference number formats, one to indicate parts in a service assembly and another to indicate the quantity of a given part in an illustration.

## Service Assembly Reference Numbers

Parts in service assemblies have reference numbers in the form a:b. The a represents the reference number of the entire service assembly and the b represents a sequential number unique to each part within the service assembly.

For example, a wheel assembly might be identified by reference number 6, the tire by 6:1, the valve by 6:2, and the wheel by 6:3. When you order the assembly identified by reference number 6, you receive all parts identified by reference numbers 6:1, 6:2, and 6:3. However, you may also order any part individually. Reference numbers of this type appear in illustration and in parts lists.

## Reference Numbers Indicating Quantity

In an illustration, if a reference number indicates more than one part, the reference number has the form nX y. The n represents the quantity of the part, the X is the multiplication symbol, and the y represents the reference number.

For example, in an illustration, the reference number 2X 37 means that two of the parts identified by reference number 37 are indicated.

# List of Abbreviations

**AR:** as required

**ASM:** assembly

**BBC:** blade brake control

**BHTF:** button head thread forming

**CARR:** carriage

**CCW:** counter clockwise

**CW:** clockwise

**DEG:** degrees

**DPA:** Dual Point Adjustment

**ECM:** electronic control module

**EXT:** external

**FH:** flat head

**GA:** gauge

**HD:** heavy-duty

**HF:** hex flange

**HH:** hex head

**HHF:** hex head flange

**HHFTF:** hex head flange thread forming

**HJ:** hex jam

**HLH:** hex lag head

**HOC:** height-of-cut

**HSBH:** hex socket button head

**HSFH:** hex socket flat head

**HSH:** hex socket head

**HWH:** hex washer head

**HWHTF:** hex washer head thread forming

**HYD:** hydraulic

**LH:** left hand

**LP:** Liquefied Petroleum Gas

**LPG:** Liquefied Petroleum Gas

**NI:** nylon insert

**NPTF:** national pipe thread fine

**PFH:** phillips flat head

**PPH:** phillips pan head

**PPHTF:** phillips pan head thread forming

**PRH:** phillips round head

**PTH:** phillips truss head

**PTO:** power-take-off

**RH:** right hand

**ROPS:** roll-over protection system

**RRB:** rear roller brush

**SFH:** slotted fillister head

**SHH:** slotted hex head

**SHWH:** slotted hex washer head

**SPH:** slotted pan head

**SQH:** square head

**SRH:** slotted round head

**STD:** standard

**TAP:** self tapping

**TTH:** torx truss head

# Contents

Main Frame Assembly . . . . .	4
Track and Drive Assembly . . . . .	5
Hydraulic Pump Assembly No. 117-6409 . . . . .	7
Hydraulic Pump Assembly No. 117-6410 . . . . .	8
Hydraulic Motor Assembly No. 104-8470 . . . . .	9
Parking Brake Assembly . . . . .	10
Engine Assembly . . . . .	11
Gear Pump Assembly No. 117-6307 . . . . .	13
Control Assembly . . . . .	14
Trencher Assembly . . . . .	16
Control Tower Assembly . . . . .	17
Hydraulic Control Assembly . . . . .	19
2-Spool Valve Assembly No. 115-4062 . . . . .	20
Oil Cooler Assembly . . . . .	21
Hydraulic Hose Routing Assembly . . . . .	22
Electrical Assembly . . . . .	23
Cylinder and Crankcase Assembly . . . . .	24
Piston and Crankshaft Assembly . . . . .	25
Valve and Camshaft Assembly . . . . .	26
Lubrication Equipment Assembly . . . . .	27
Cooling Equipment Assembly . . . . .	28
Electric Equipment Assembly . . . . .	29
Carburetor Assembly . . . . .	30
Control Equipment Assembly . . . . .	32
Air Filter and Muffler Assembly . . . . .	33
Fuel Tank and Valve Assembly . . . . .	34
Starter Assembly . . . . .	35
Label Set . . . . .	36
Attachments and Accessories . . . . .	37

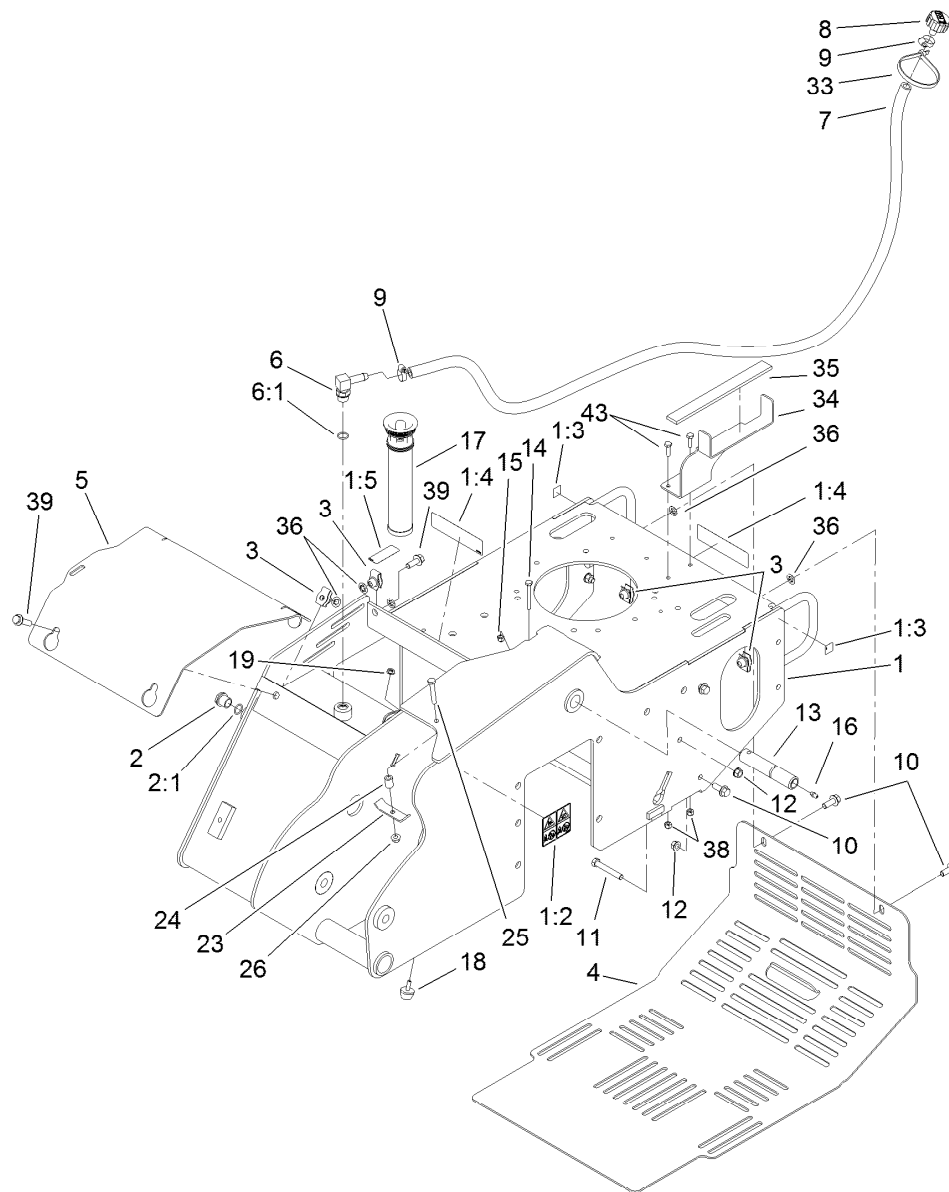

## Main Frame Assembly

Ref.	Part Number	Qty.	Description	Ref.	Part Number	Qty.	Description
1	114-8630	1	Main Frame ASM	13	120-7352	1	Pin-Pivot
1:2	100-4650	1	Decal-Warning	14	321-18	1	Screw-HH
1:3	93-9084	2	Decal-Point, Lift	15	3296-42	1	Nut-Lock, NI
1:4	93-7814	2	Decal-Danger	16	302-5	1	Fitting-Grease
1:5	93-6686	1	Decal-Oil, HYD	17	114-3039	1	In-Tank Filter ASM
2	114-3075	1	Sight Glass ASM	18	1-523420	1	Bumper
2:1	237-79	1	O-Ring	19	32128-33	1	Nut-HF
3	112-4576	5	Nut-Clip, U	23	100-4860	1	Bracket-Clamp
4	115-6503-01	1	Cover-Rear	24	93-5023	1	Spacer
5	119-4566-03	1	Plate-Cover, Front	25	322-10	1	Screw-HH
6	354-120	1	Fitting-HYD, 90 DEG	26	32128-20	1	Nut-HF
6:1	237-79	1	O-Ring	33	3334-945	1	Tie-Cable
7	114-3042	1	Hose-Breather	34	117-6407-01	1	Bracket-Fuel Tank
8	68-6150	1	Breather	35	117-6417	1	Pad-Foam
9	2412-36	2	Clamp-Hose	36	107-3154	5	Nut-Push
10	3234-11	2	Screw-HHF	38	3296-42	2	Nut-Lock, NI
11	323-12	1	Screw-HH	39	3234-18	3	Screw-HHF
12	32128-40	2	Nut-Flange	43	321-6	2	Screw-HH

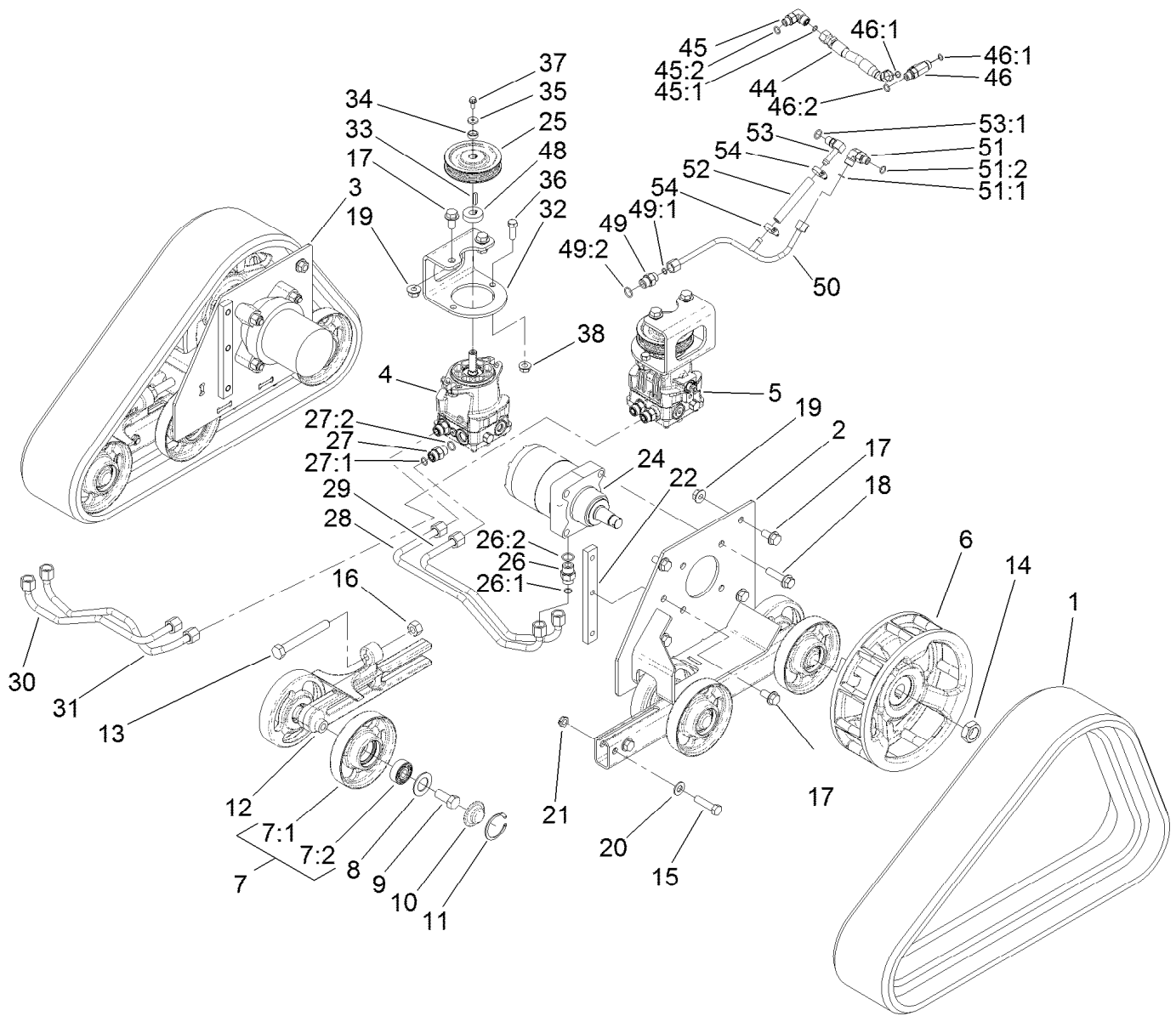

## Track and Drive Assembly

Ref.	Part Number	Qty.	Description	Ref.	Part Number	Qty.	Description
1	112-4816	2	Track-Rubber	20	3256-26	4	Washer-Flat
2	114-2992-03	1	Frame-Track, LH	21	3296-45	4	Nut-Lock, NI
3	114-2993-03	1	Frame-Track, RH	22	114-3091	2	Bar-Thread
4	117-6409	1	RH HYD Pump ASM	24	104-8470	2	HYD Wheel Motor ASM
5	117-6410	1	LH HYD Pump ASM	25	115-1298	2	Sheave
6	117-6426-03	2	Wheel-Drive	26	340-6	4	Fitting-HYD, Straight
7	112-4817	12	Wheel-Tensioner	26:1	237-30	1	O-Ring
7:1	114-3014-03	1	Wheel-Track	26:2	237-80	1	O-Ring
7:2	120-5378	1	Bearing-Ball	27	340-4	4	Fitting-HYD, Straight
8	106-7585	12	Gasket-Bogie	27:1	237-30	1	O-Ring
9	327-4	12	Screw-HH	27:2	237-79	1	O-Ring
10	106-7557	12	Cap-Wheel, Bearing	28	115-1285	1	HYD Tube ASM
11	106-7595	12	Ring-Snap, Internal	29	115-1286	1	HYD Tube ASM
12	114-3077-03	2	Tensioner-Track	30	115-1287	1	HYD Tube ASM
13	112-4874	2	Screw-HH, TAP	31	115-1288	1	HYD Tube ASM
14	106-8159	2	Nut-Lock	32	115-1289-03	2	Bracket-Mount, Pump
15	325-8	4	Screw-HH	33	80-6090	2	Key-Pump
16	3217-11	2	Nut-Hex	34	108-4211	2	Bushing
17	3234-6	10	Screw-HHF	35	73-3580	2	Washer
18	3234-27	8	Screw-HHF	36	324-5	4	Screw-HH
19	32128-49	8	Nut-HHF	37	33103-016	2	Screw-HHF

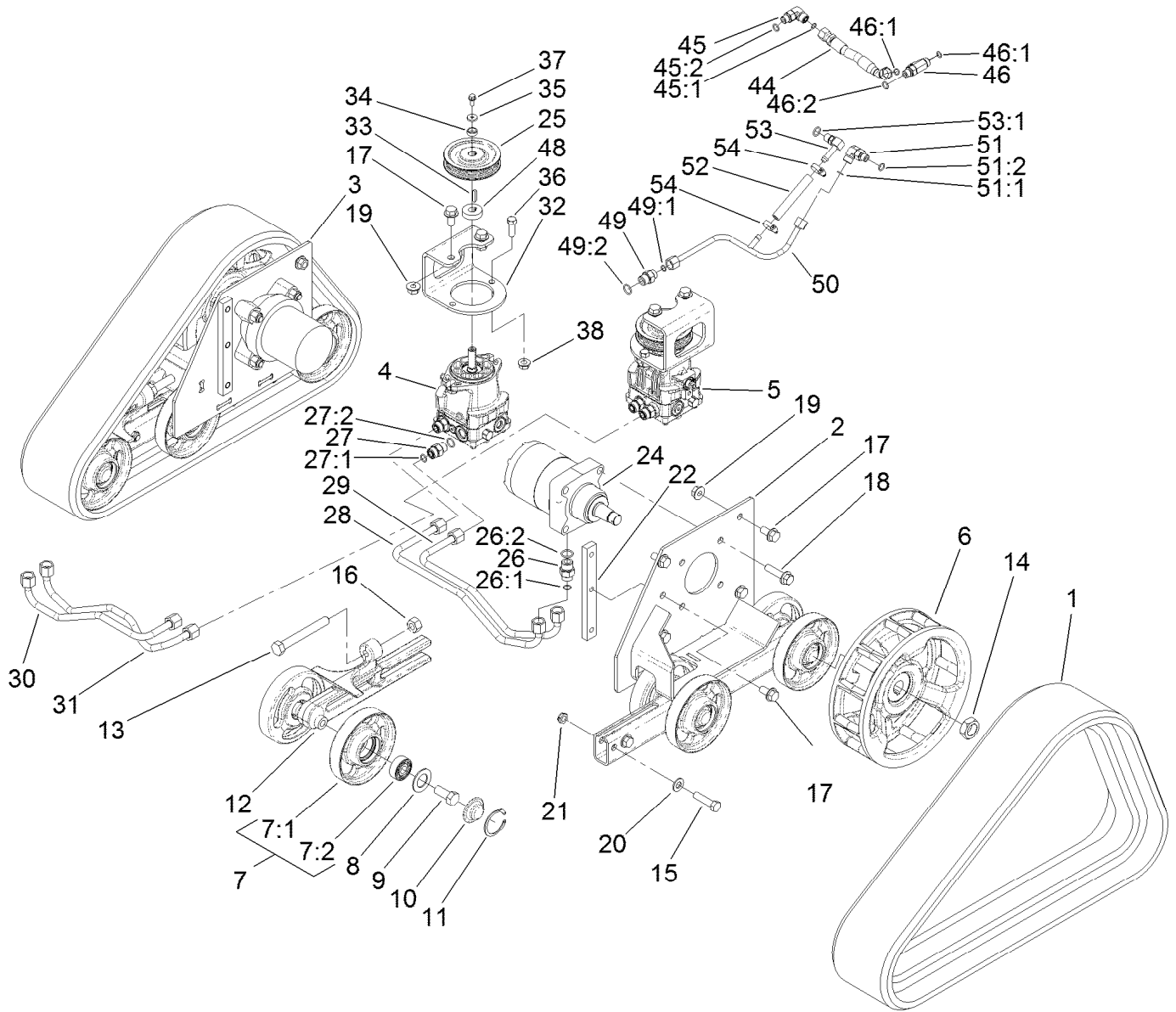

## Track and Drive Assembly (continued)

<i>Ref.</i>	<i>Part Number</i>	<i>Qty.</i>	<i>Description</i>	<i>Ref.</i>	<i>Part Number</i>	<i>Qty.</i>	<i>Description</i>
38	32128-42	4	Nut-HF	49:1	237-22	1	O-Ring
44	115-1297	1	HYD Hose ASM	49:2	237-79	1	O-Ring
45	340-77	1	Fitting-HYD, 90 DEG	50	117-1305	1	HYD Tube ASM
45:1	237-22	1	O-Ring	51	340-77	1	Fitting-HYD, 90 DEG
45:2	237-42	1	O-Ring	51:1	237-22	1	O-Ring
46	340-86	1	Fitting-Tee	51:2	237-42	1	O-Ring
46:1	237-22	2	O-Ring	52	115-4083	1	Hose
46:2	237-42	1	O-Ring	53	100-4887	1	Fitting-Barbed, 90 DEG
48	115-4002	2	Spacer	53:1	237-42	1	O-Ring
49	340-3	1	Adapter	54	2412-36	2	Clamp-Hose

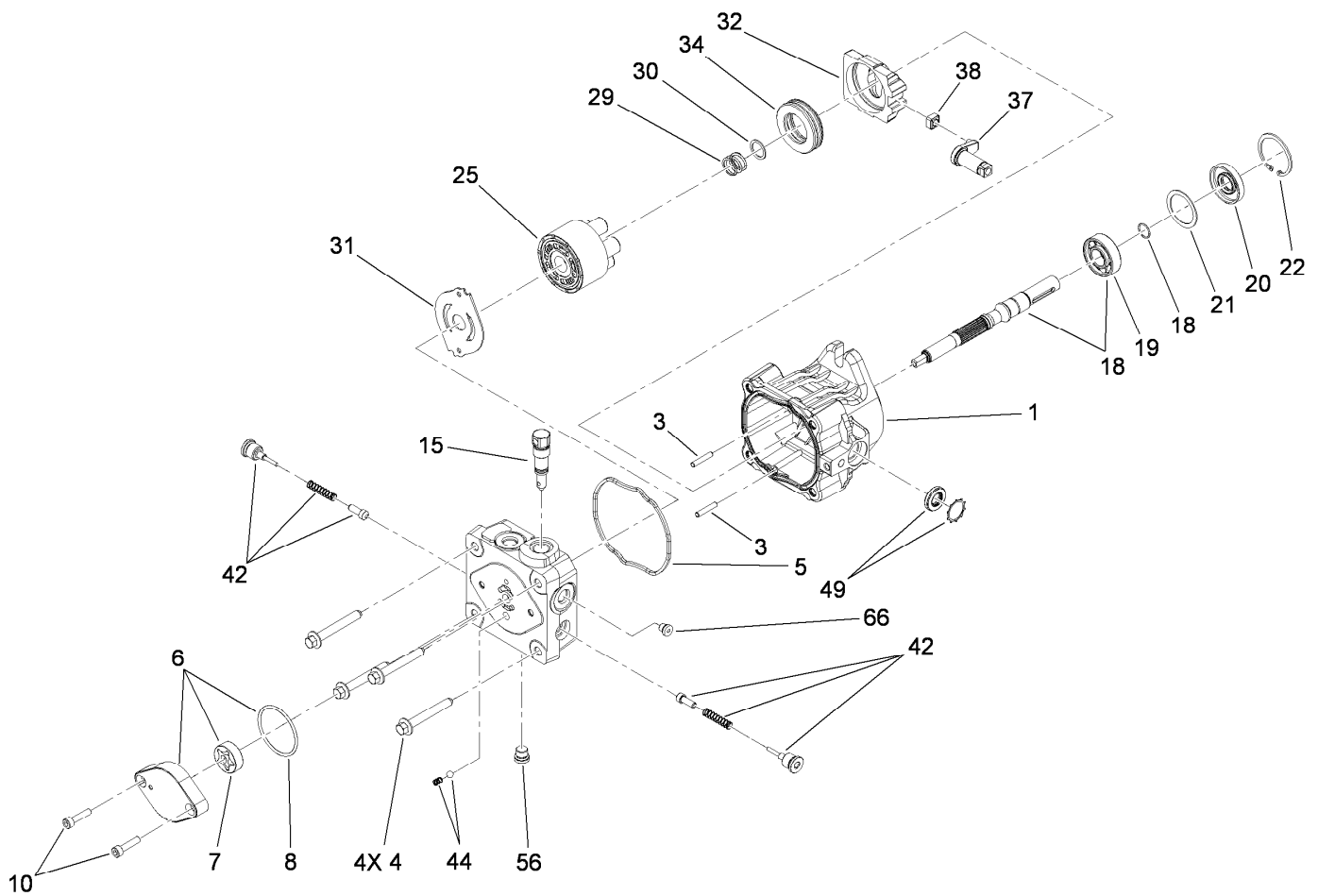

## Hydraulic Pump Assembly No. 117-6409

Ref.	Part Number	Qty.	Description	Ref.	Part Number	Qty.	Description
1	115-4464	1	Housing Kit	29	94-1936	1	Spring-Block
3	106-8753	2	Pin-Headless, Straight	30	94-1937	1	Washer-Thrust
4	106-8754	4	Bolt-HF	31	105-6185	1	Plate-Valve
5	106-8755	1	O-Ring	32	94-1907	1	Swashplate-Variable
6	106-8756	1	Charge Pump Kit	34	94-6922	1	Bearing-Thrust
7	104-2122	1	Gerotor ASM	37	115-4458	1	Arm-Trunnion, Tapered Square
8	106-8757	1	O-Ring	38	94-1910	1	Guide-Slot
10	104-2111	2	Capscrew	42	98-3252	2	Valve-Check (W/Poppet)
15	106-8759	1	Bypass Valve Kit	44	106-8760	1	Charge Relief Valve Kit
18	103-2664	1	Input Shaft Kit	49	114-8155	1	Trunnion Seal Kit
19	104-5311	1	Bearing-Ball	56	106-8762	1	Plug-HSH
20	104-5310	1	Seal-Lip	66	106-8763	1	Plug-HSH
21	104-5308	1	Spacer	99	105-6184	1	Seal Overhaul Kit ●
22	104-5309	1	Ring-Retaining				
25	103-2666	1	Cylinder Block Kit				

● Not illustrated

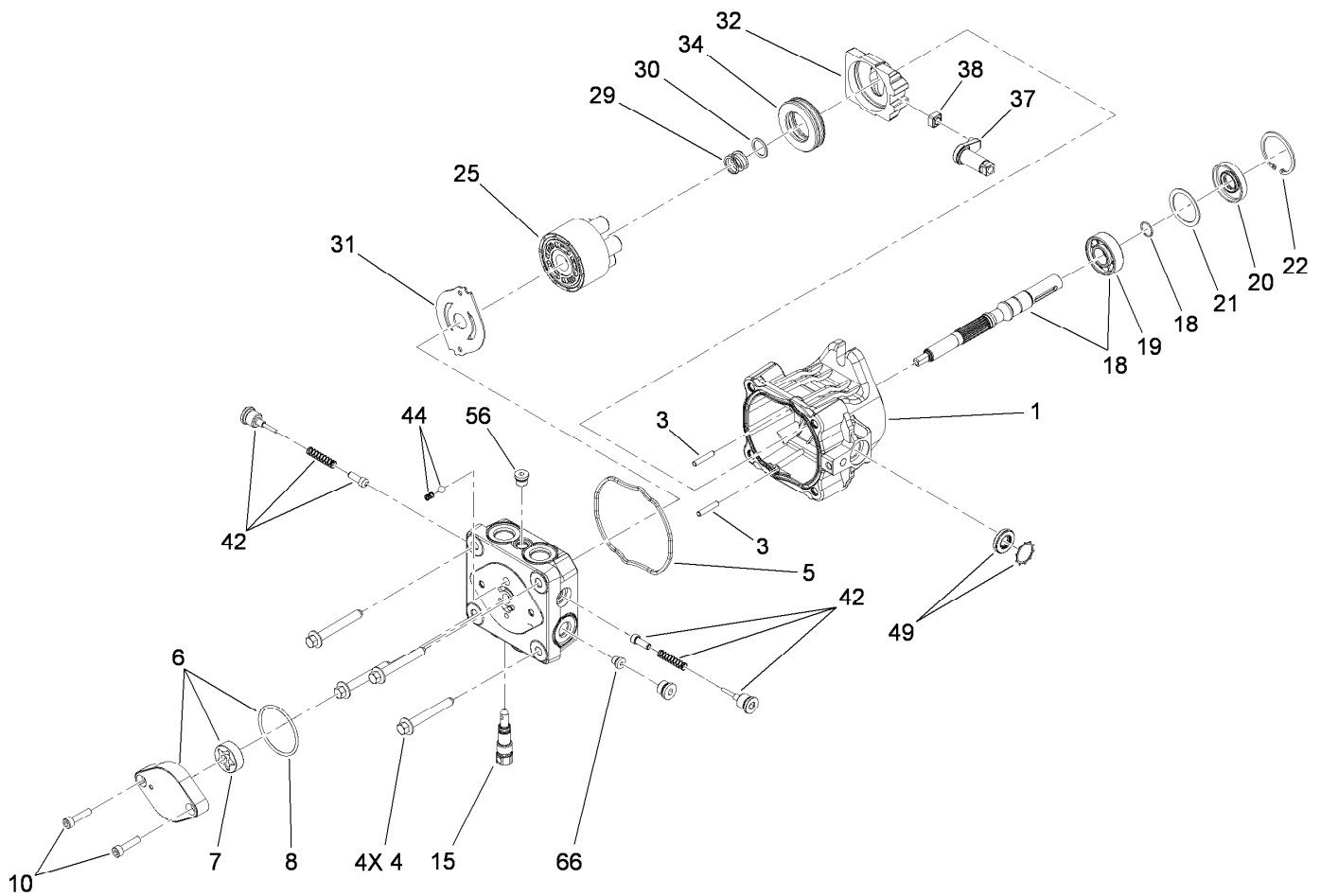

## Hydraulic Pump Assembly No. 117-6410

Ref.	Part Number	Qty.	Description	Ref.	Part Number	Qty.	Description
1	115-4464	1	Housing Kit	29	94-1936	1	Spring-Block
3	106-8753	2	Pin-Headless, Straight	30	94-1937	1	Washer-Thrust
4	106-8754	4	Bolt-HF	31	105-6185	1	Plate-Valve
5	106-8755	1	O-Ring	32	94-1907	1	Swashplate-Variable
6	106-8756	1	Charge Pump Kit	34	94-6922	1	Bearing-Thrust
7	104-2122	1	Gerotor ASM	37	115-4458	1	Arm-Trunnion, Tapered Square
8	106-8757	1	O-Ring	38	94-1910	1	Guide-Slot
10	104-2111	2	Capscrew	42	98-3252	2	Valve-Check (W/Poppet)
15	106-8759	1	Bypass Valve Kit	44	106-8760	1	Charge Relief Valve Kit
18	103-2664	1	Input Shaft Kit	49	114-8155	1	Trunnion Seal Kit
19	104-5311	1	Bearing-Ball	56	106-8762	1	Plug-HSH
20	104-5310	1	Seal-Lip	66	106-8763	1	Plug-HSH
21	104-5308	1	Spacer	99	105-6184	1	Seal Overhaul Kit ●
22	104-5309	1	Ring-Retaining				
25	103-2666	1	Cylinder Block Kit				

● Not illustrated



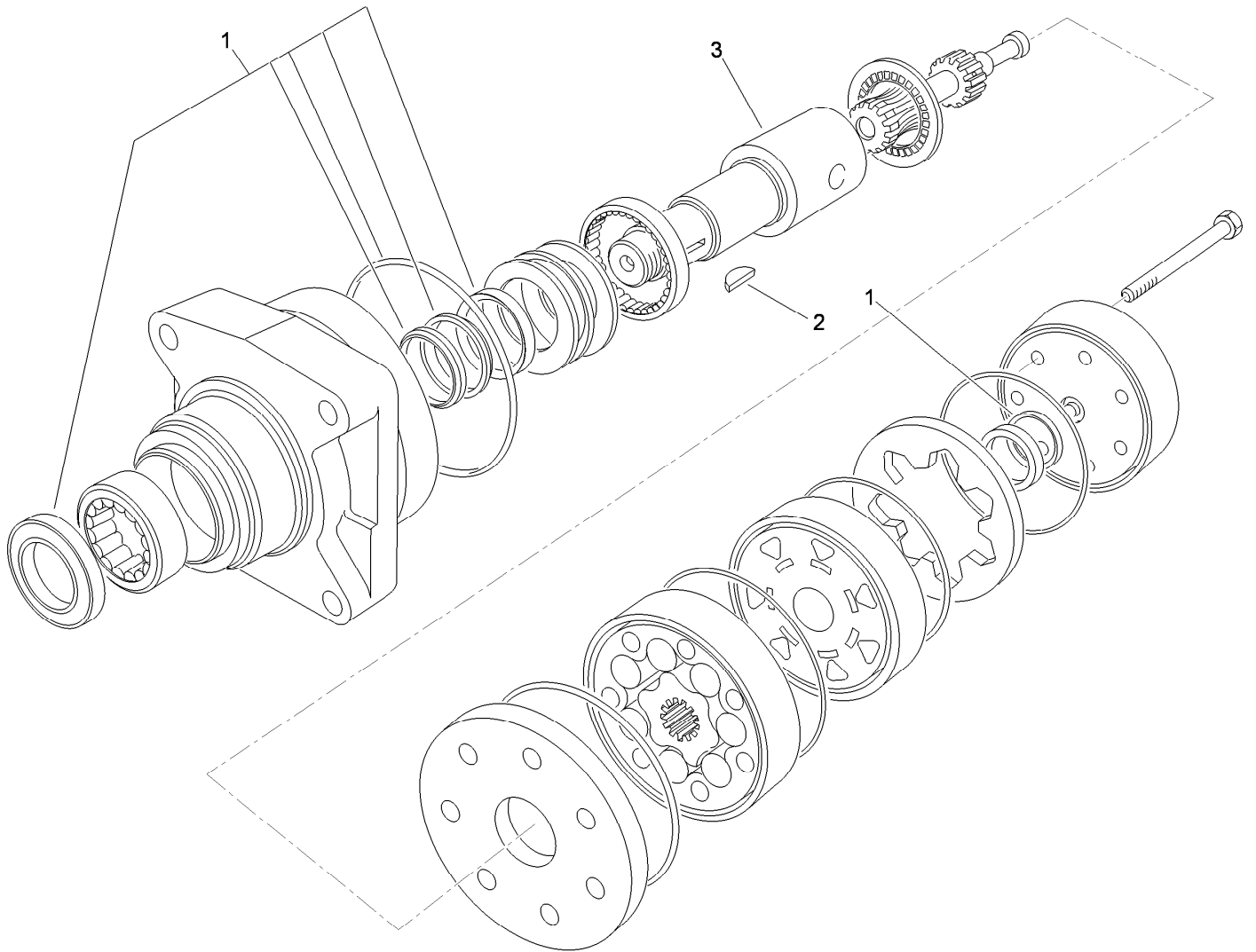

## Hydraulic Motor Assembly No. 104-8470

<i>Ref.</i>	<i>Part Number</i>	<i>Qty.</i>	<i>Description</i>
1	115-4061	1	Seal Kit
2	3257-42	1	Key-Woodruff
3	99-3090	1	Shaft-Coupling

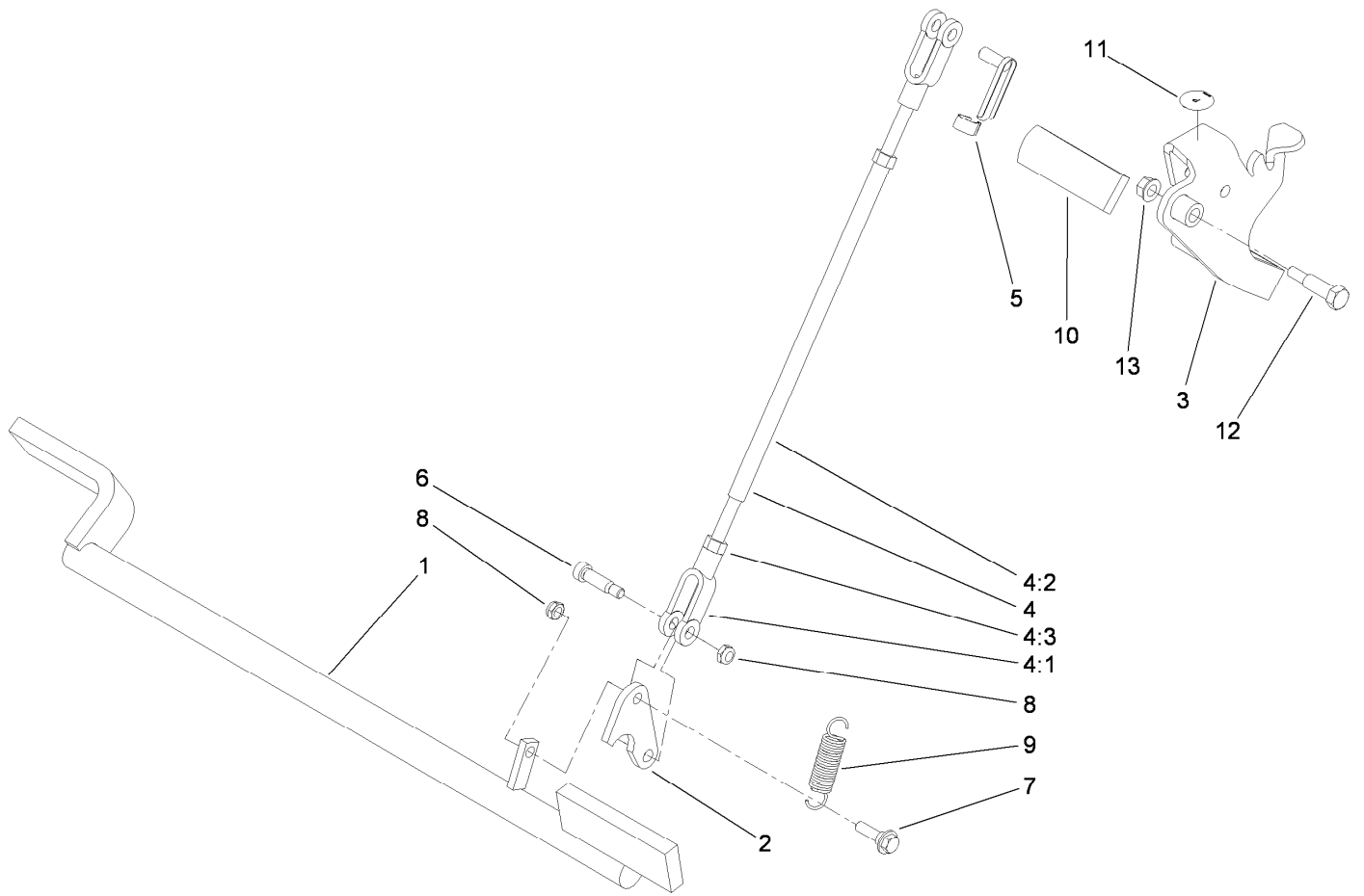

## Parking Brake Assembly

<i>Ref.</i>	<i>Part Number</i>	<i>Qty.</i>	<i>Description</i>	<i>Ref.</i>	<i>Part Number</i>	<i>Qty.</i>	<i>Description</i>
1	114-2972-03	1	Bar-Brake	6	114-8629	1	Bolt-Shoulder
2	114-2975	1	Link-Mounting	7	27-7211	1	Screw-Shoulder
3	117-6421-03	1	Handle-Brake	8	3296-47	2	Nut-Lock, NI
4	103-4335	1	Brake Rod ASM	9	67-1450	1	Spring-Idler
4:1	1-633131	2	Yoke-Linkage, Brake	10	62-9130	1	Grip-Handle
4:2	103-3907	1	Linkage-Handle, Brake	11	107-8495	1	Decal-Parking Brake
4:3	3219-3	2	Nut-Hex	12	7-0030	1	Screw-Shoulder, HH
5	103-2399	1	Pin-Spring, Clevis	13	32128-20	1	Nut-HF

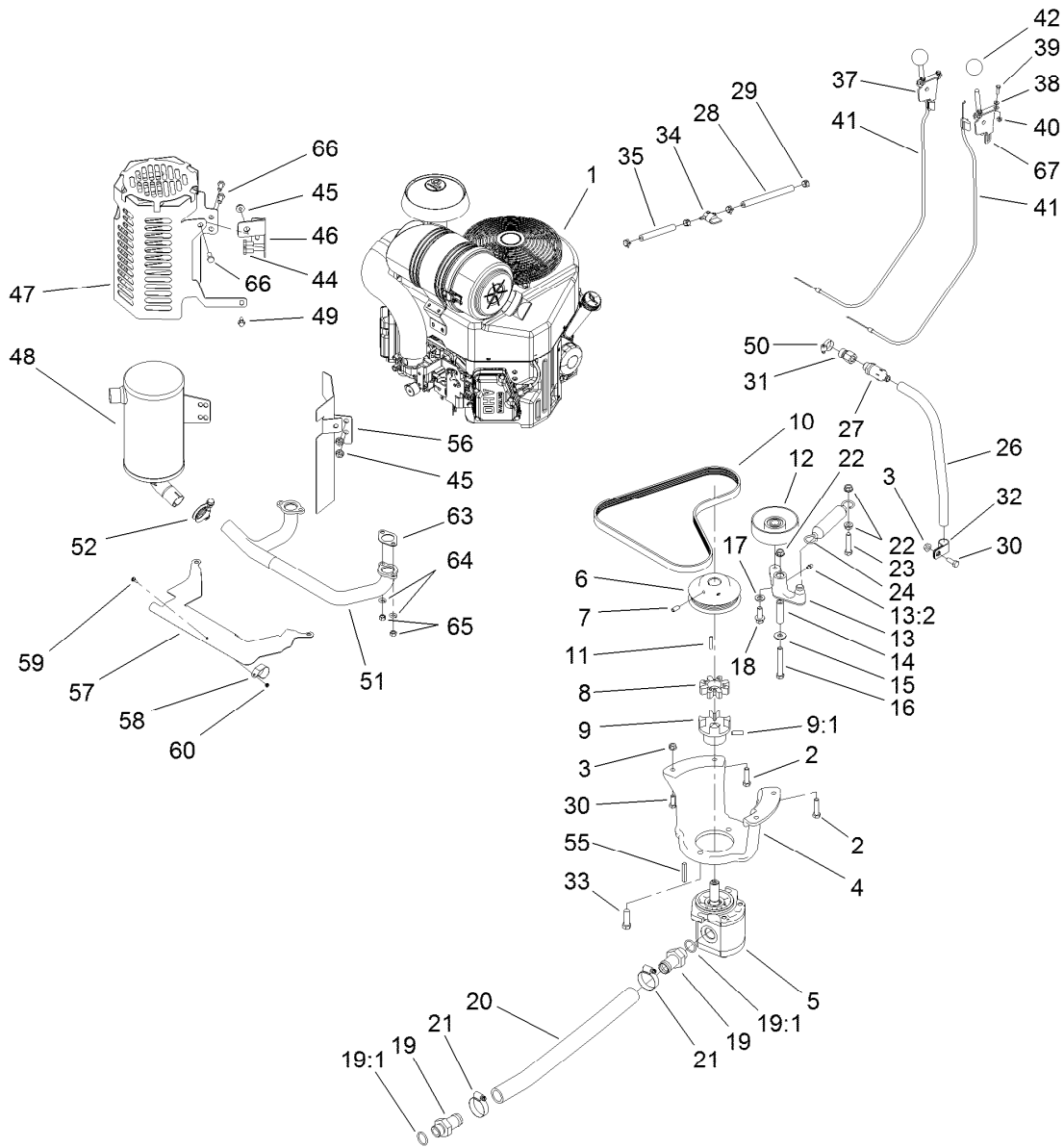

## Engine Assembly

Ref.	Part Number	Qty.	Description	Ref.	Part Number	Qty.	Description
1	117-6305	1	Engine-Kawasaki, Fx730V	19:1	237-81	1	O-Ring
2	323-8	4	Screw-HH	20	114-2917	1	Hose-Suction
3	32128-20	3	Nut-HF	21	2412-111	2	Clamp
4	115-1480-03	1	Mount-Pump	22	3290-357	3	Nut-HHF, Whiz
5	117-6307	1	Gear Pump ASM	23	323-9	1	Screw-HH
6	114-8559-03	1	Pulley-Engine	24	66-4270	1	Spring-Extension
7	3246-6	2	Screw-Set, HSH	26	106-5709	1	Hose-Vent
8	93-8827	1	Spider-Coupler	27	92-6877	1	Valve-Drain, Oil
9	114-2933	1	Coupler-Flex	28	109-0306	1	Hose-Fuel
9:1	100-7594	1	Screw-Set	29	2412-98	4	Clamp-Hose
10	114-2991	1	Belt-V	30	322-4	3	Screw-HH
11	608006	1	Key-Square	31	103-1966	1	Adapter
12	95-8802	1	Pulley-Idler	32	2412-81	1	Clamp-R
13	117-6323	1	Idler Arm ASM	33	324-6	2	Screw-HH
13:2	302-5	1	Fitting-Grease	34	1-603770	1	Valve-Fuel
14	114-2916	1	Bushing-Idler	35	109-0295	1	Hose-Fuel
15	3256-4	1	Washer-Flat	37	108-9730	1	Lever-Control
16	323-13	1	Screw-HH	38	3256-21	4	Washer-Flat
17	3256-24	1	Washer-Flat	39	3290-134	4	Screw
18	3234-11	1	Screw-HHF	40	3296-2	4	Nut-Lock, NI
19	99-3017	2	Fitting	41	115-1211	2	Cable-Control

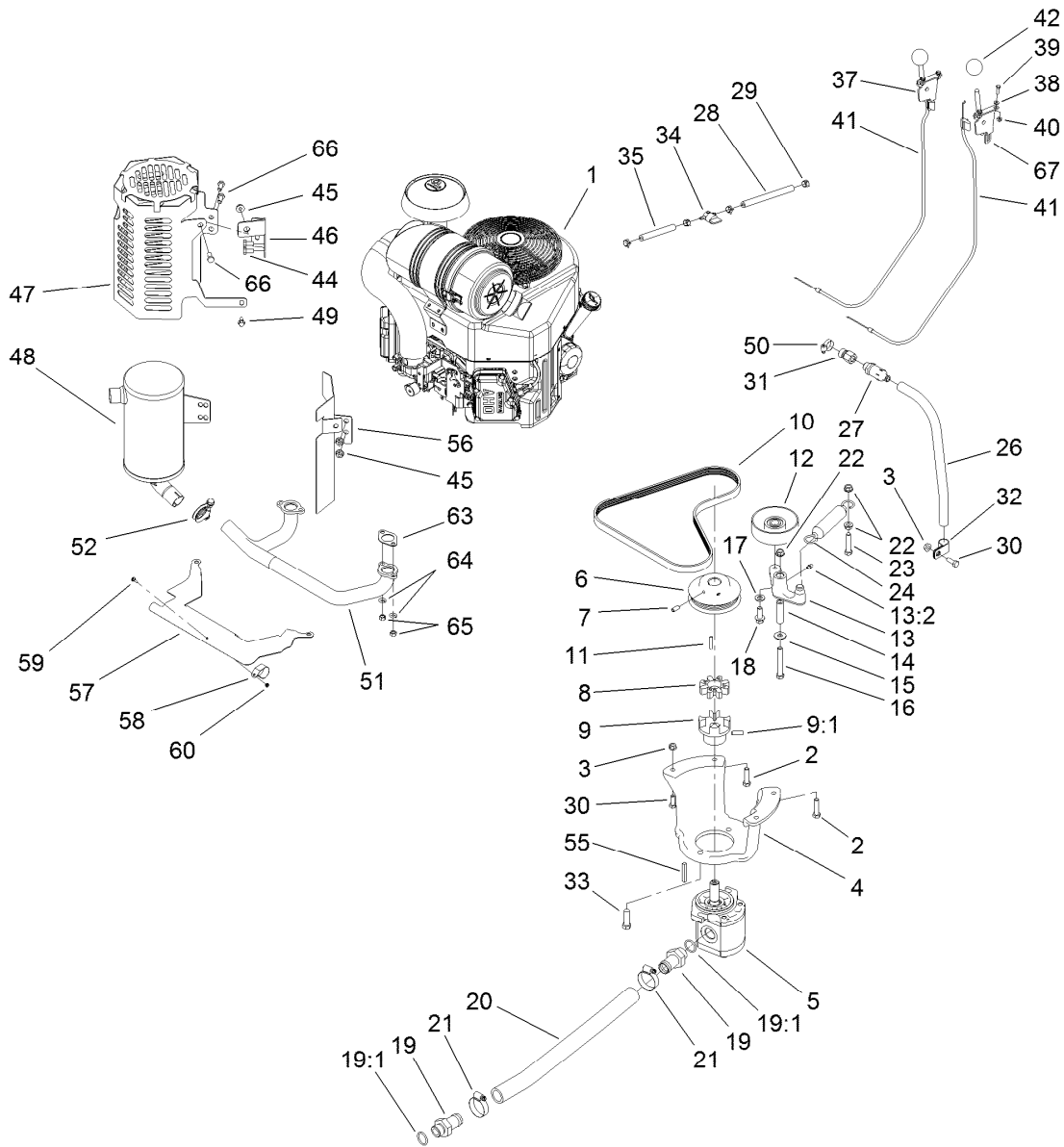

## Engine Assembly (continued)

Ref.	Part Number	Qty.	Description	Ref.	Part Number	Qty.	Description
42	233-42	2	Knob	56	117-6337	1	Bracket-Shield, Heat
44	33114-016	2	Screw-HH	57	115-9227	1	Plate-Shield, Heat
45	112-2844	3	Nut-HF	58	115-6488	1	Clamp
46	115-9233-03	1	Bracket-Mount, Muffler	59	115-6494	1	Screw-Pan
47	115-9234-03	1	Shield-Muffler	60	115-6495	1	Nut-Hex
48	117-6319	1	Muffler	63	1-653313	2	Gasket-Exhaust
49	33103-016	1	Screw-HHF	64	115-6496	4	Washer-Spring (F/W Engine)
50	2412-36	1	Clamp-Hose	65	115-6611	4	Nut-Hex (F/W Engine)
51	117-6318	1	Manifold	66	33114-020	3	Screw-HH
52	2112-11	1	Clamp-Muffler	67	110-5547	1	Lever-Control
55	27-8590	1	Key-Square				

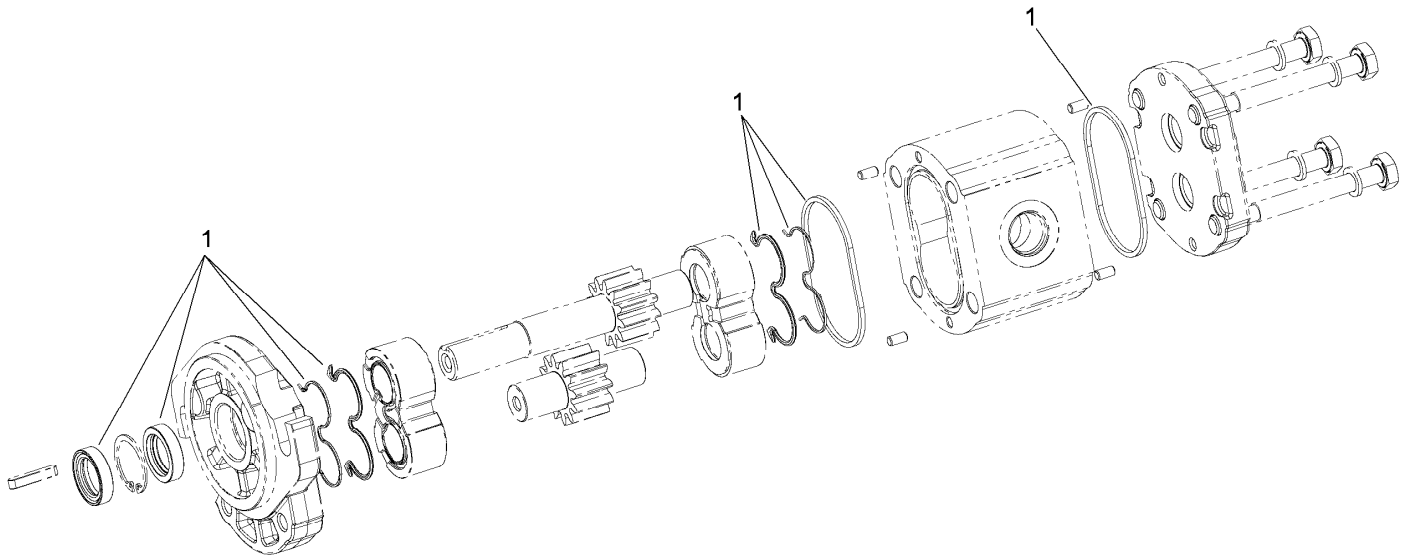

## **Gear Pump Assembly No. 117-6307**

<i>Ref.</i>	<i>Part Number</i>	<i>Qty.</i>	<i>Description</i>
1	115-1265	1	Seal Kit

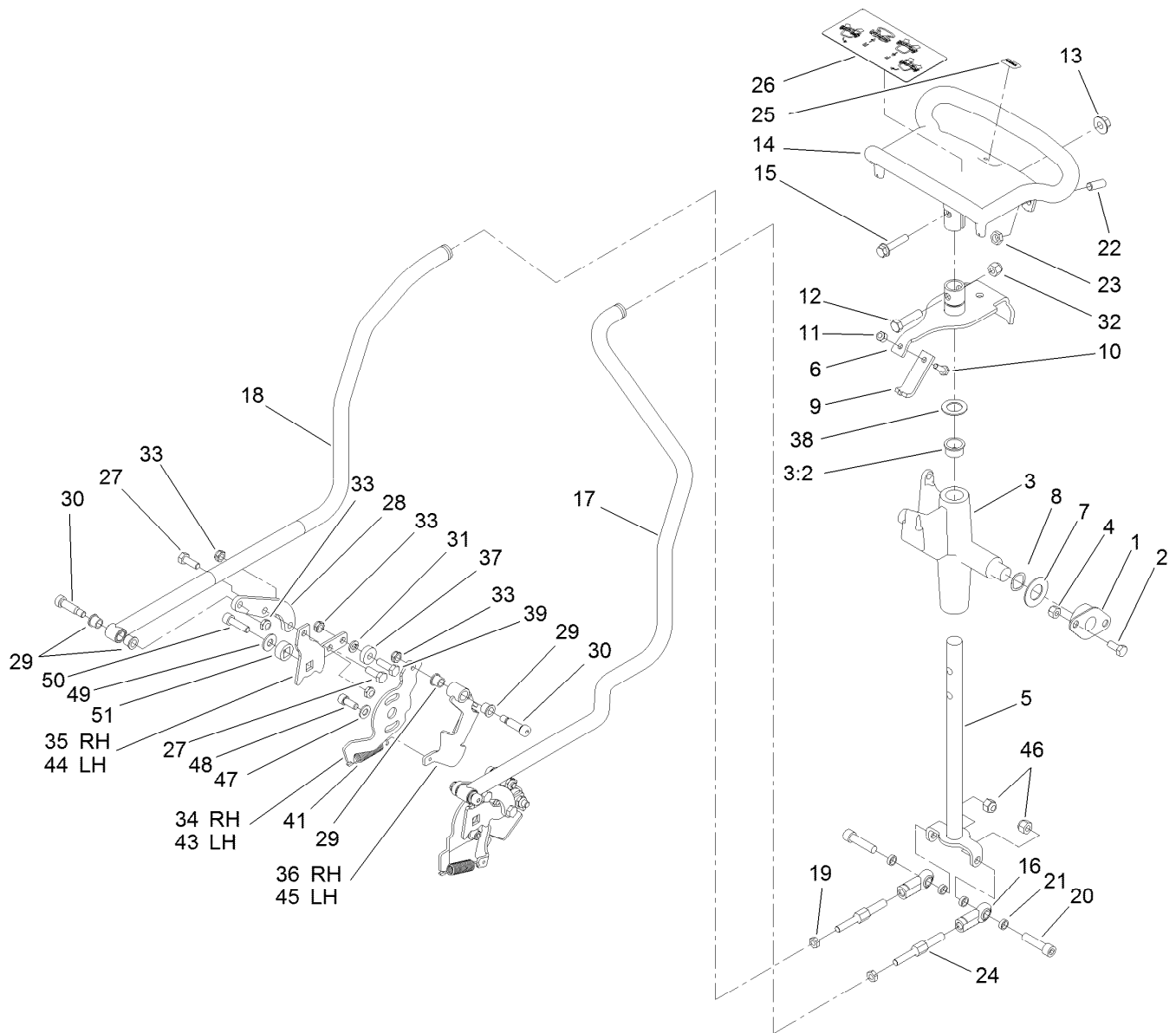

## Control Assembly

Ref.	Part Number	Qty.	Description	Ref.	Part Number	Qty.	Description
1	68-2970	2	Bushing	21	108-0634	4	Spacer-Plate, Retaining
2	322-3	4	Screw-HH	22	3247-6	2	Screw-Set
3	106-5737	1	Control Support ASM	23	3218-3	2	Nut-Jam
3:2	256-252	2	Bearing-Flange	24	117-6334	2	Link-Control, Adjustment
4	3296-29	4	Nut-Lock, NI	25	98-1459	1	Decal
5	117-6335	1	Rod-Drive	26	115-4020	1	Decal-Traction
6	112-2783	1	Lever-Pivot	27	322-4	4	Screw-HH
7	3256-39	2	Washer-Flat	28	115-1290	2	Plate-Adapter, Control, RH
8	95-3703	2	Washer-Spring, Wave	29	256-116	8	Bushing-Flange
9	115-1204	1	Plate-Neutral	30	114-8629	4	Bolt-Shoulder
10	321-4	1	Screw-HH	31	3253-4	2	Washer-Lock
11	3296-42	1	Nut-Lock, NI	32	3296-39	1	Nut-Lock, NI
12	323-8	1	Screw-HH	33	3296-47	10	Nut-Lock, NI
13	32128-43	1	Nut-Flange	34	115-6535	1	Plate-Base, RH
14	120-5380-03	1	Handle-Control	35	115-6536	1	Plate-Arm, Return
15	3234-18	1	Screw-HHF	36	115-6636	1	Pivot-RH
16	103-1167	2	Joint-Ball End, LH	37	251-259	2	Bearing-Ball
17	114-2901	1	Rod-Control, LH	38	257-8	1	Washer-Thrust
18	114-2902	1	Rod-Control, RH	39	322-5	2	Screw-HH
19	3220-2	2	Nut-Jam	41	121-4409	2	Spring-Extension
20	3274-2	2	Screw-HSH	43	115-6549	1	Plate-Base, LH

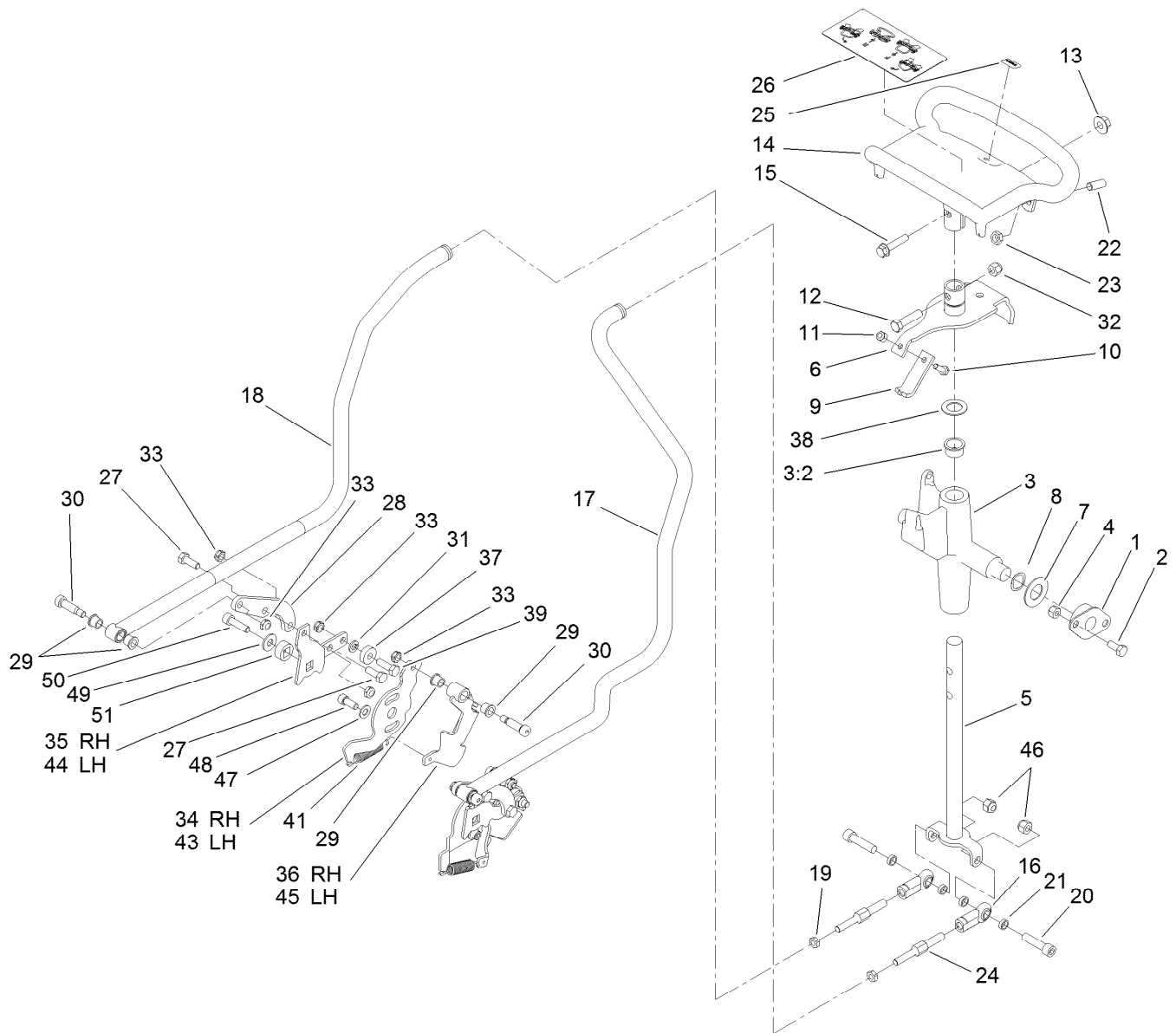

## Control Assembly (continued)

<i>Ref.</i>	<i>Part Number</i>	<i>Qty.</i>	<i>Description</i>	<i>Ref.</i>	<i>Part Number</i>	<i>Qty.</i>	<i>Description</i>
44	115-6628	1	Plate-Arm, Return, LH	48	3273-14	2	Screw-HSH
45	115-6637	1	Pivot-LH	49	3256-3	2	Washer-Flat
46	3296-39	2	Nut-Lock, NI	50	94-3559	2	Screw-HSH
47	3290-456	2	Washer-Belleville	51	117-6429	2	Lock-Trunion

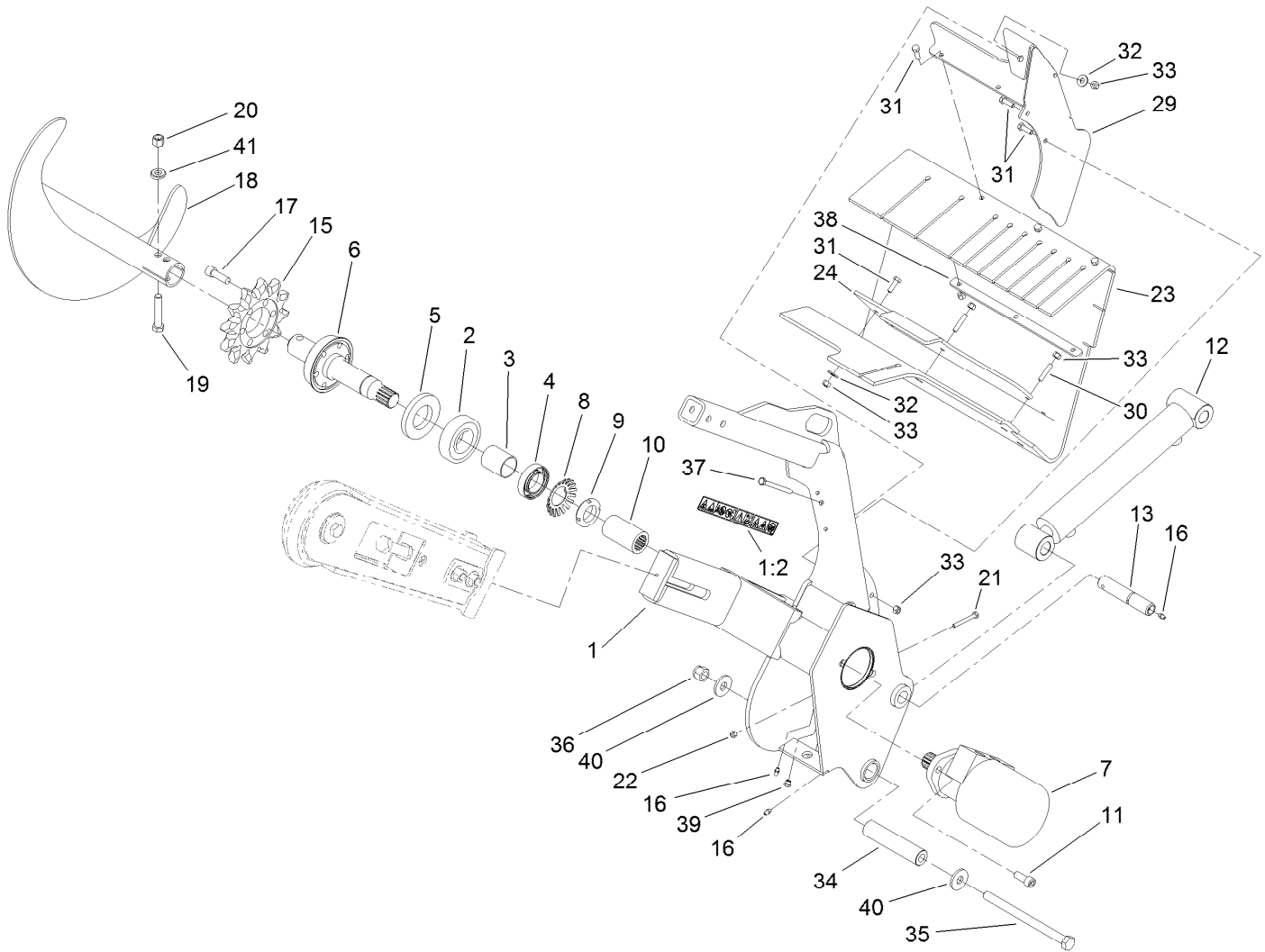

## Trencher Assembly

Ref.	Part Number	Qty.	Description	Ref.	Part Number	Qty.	Description
1	117-6423	1	Trencher Head ASM	20	3296-23	1	Nut-Lock, NI
1:2	99-9952	2	Decal-Danger	21	321-18	1	Screw-HH
2	106-8871	1	Bearing-Ball	22	3296-42	1	Nut-Lock, NI
3	112-4979	1	Spacer	23	117-6317	1	Shield-Dirt
4	111199	1	Bearing-Ball	24	117-6316-03	1	Bar-Clamp
5	114-2955	1	Seal-Grease	29	115-1279-03	1	Bracket-Shield
6	117-6308	1	Shaft-Trencher	30	115-4049	2	Screw-HSH
7	117-6306	1	Hydraulic Motor ASM	31	322-5	8	Screw-HH
8	114-2956	1	Lockwasher-Bearing	32	3256-3	4	Washer-Flat
9	88-1450	1	Locknut-Bearing	33	3296-29	11	Nut-Lock, NI
10	117-6315	1	Collar-Splined	34	114-8573	1	Spacer-Pivot
11	3274-89	2	Screw-HSH	35	117-6327	1	Bolt-HH
12	121-1955	1	HYD Cylinder ASM	36	3296-53	1	Nut-Lock, NI
13	120-7352	1	Pin-Pivot	37	322-23	1	Screw-HH
15	104-1964	1	Sprocket-Trencher	38	115-4001-03	1	Plate-Strap, Shield
16	302-5	3	Fitting-Grease	39	302-34	1	Fitting-Lube
17	3274-4	6	Screw-HSH	40	104-9216	2	Washer-Hardened
18	117-8852-03	1	Auger-Trencher	41	117-3479	2	Washer-Saddle
19	325-13	1	Screw-HH				



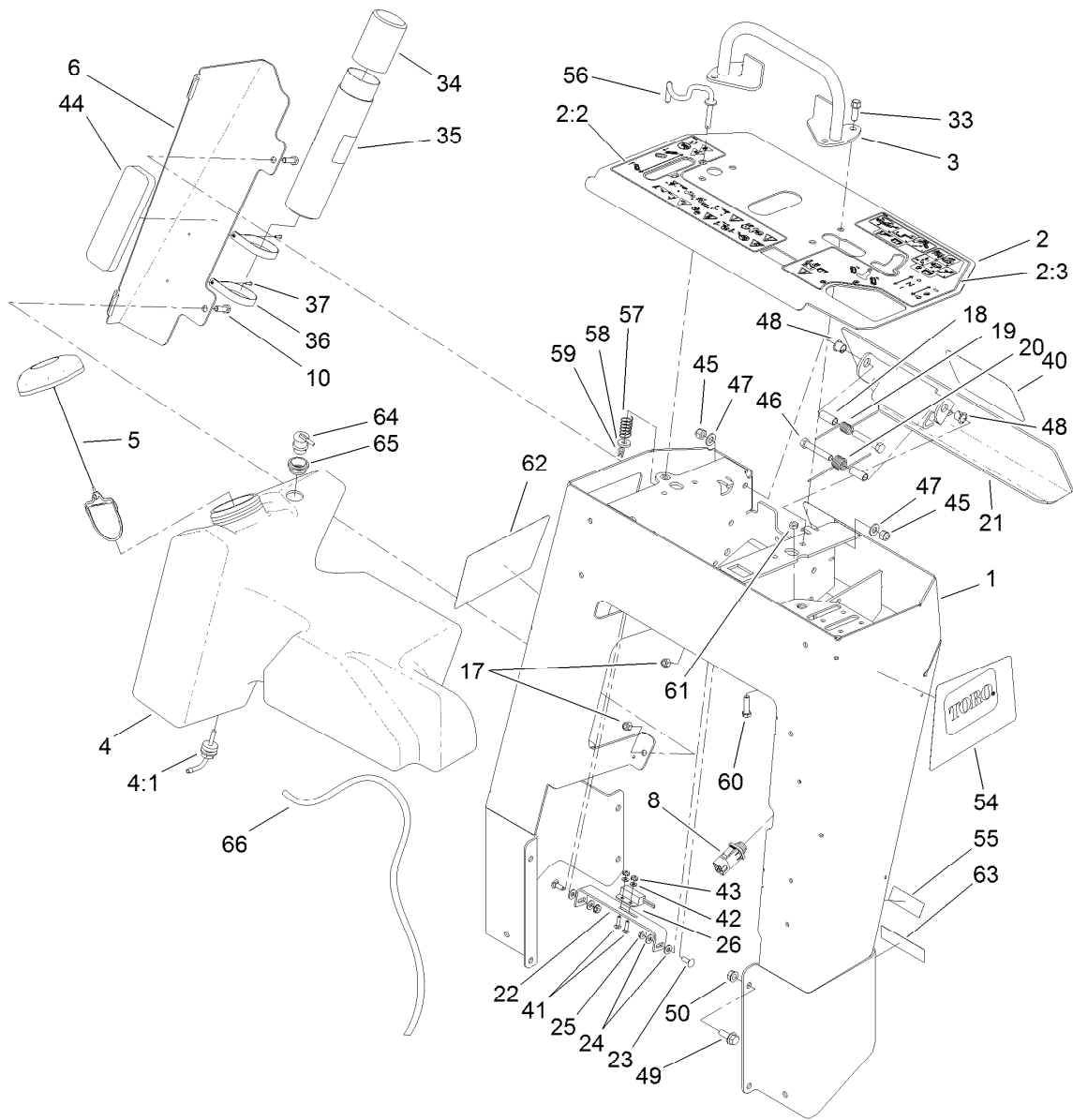

## Control Tower Assembly

Ref.	Part Number	Qty.	Description	Ref.	Part Number	Qty.	Description
1	117-6419-01	1	Tower	33	95-1726	4	Screw-Taptite
2	117-6389	1	Panel-Control	34	104-7048	1	Cap-Housing
2:2	115-1231	1	Decal-Console, RH	35	104-7050	1	Tube-Manual
2:3	115-1230	1	Decal-Console, LH	36	2412-120	2	Clamp-R
3	106-7715	1	Bar-Reference	37	3269-17	2	Rivet-Pop
4	120-7358	1	Tank-Fuel	40	105-1217	1	Decal
4:1	103-2605	1	Fitting-Fuel, Bulkhead	41	3229-20	2	Screw-CARR
5	120-5461	1	Cap-Fuel, Ratcheting	42	3256-51	2	Washer-Flat
6	114-3065-01	1	Bracket-Cover, Tank	43	32149-7	2	Nut-Keps
8	100-1268	1	Switch-Plunger	44	107-7507	1	Pad-Foam
10	322-5	2	Screw-HH	45	3296-39	2	Nut-Lock, NI
17	3296-29	2	Nut-Lock, NI	46	323-11	2	Screw-HH
18	114-1337	2	Spacer-Spring	47	3256-24	2	Washer-Flat
19	98-8425	1	Spring-Torsion, LH	48	256-257	2	Bushing-Nyliner
20	98-8424	1	Spring-Torsion, RH	49	3234-11	8	Screw-HHF
21	114-3012-03	1	Plate-Reverse	50	32128-40	8	Nut-Flange
22	100-1263	1	Plate-Switch	54	117-6415	1	Decal-Side, LH
23	3229-1	2	Bolt-CARR	55	120-7533	1	Decal-Info
24	3256-22	4	Washer-Flat	56	114-8727	1	Rod-Interlock
25	32149-2	2	Nut-Keps	57	85-6750	1	Spring-Control
26	100-1270	1	Switch-Proximity	58	88-7200	1	Washer-Flat

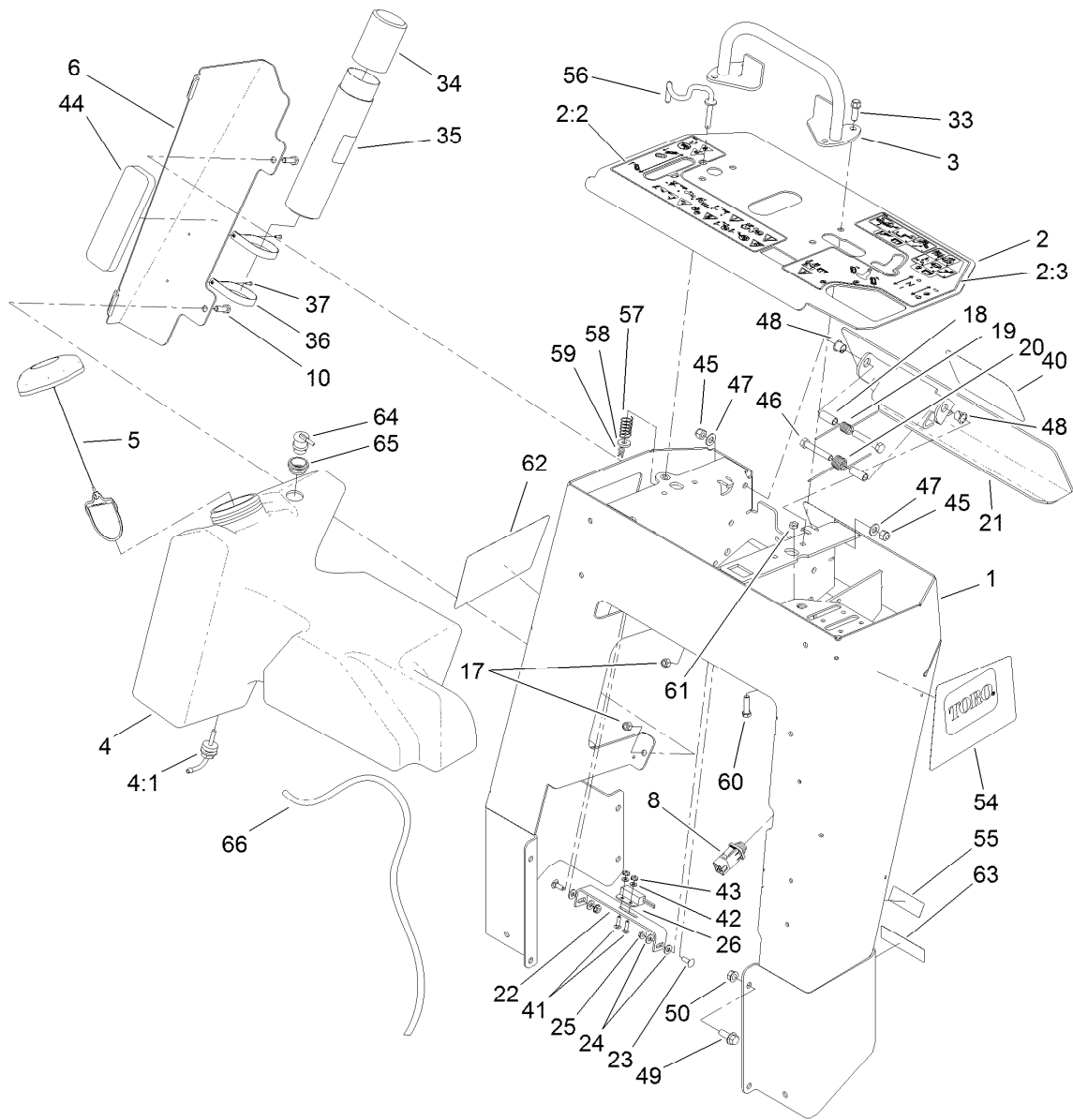

## Control Tower Assembly (continued)

<i>Ref.</i>	<i>Part Number</i>	<i>Qty.</i>	<i>Description</i>	<i>Ref.</i>	<i>Part Number</i>	<i>Qty.</i>	<i>Description</i>
59	3290-307	1	Pin-Hair	63	117-2718	1	Decal-Arrester, Spark
60	3210-7	1	Screw-HH	64	114-0285	1	Valve-Rollover
61	3220-2	2	Nut-Jam	65	114-0284	1	Grommet
62	117-6416	1	Decal-Side, RH	66	117-6396	1	Hose-Vent, Tank

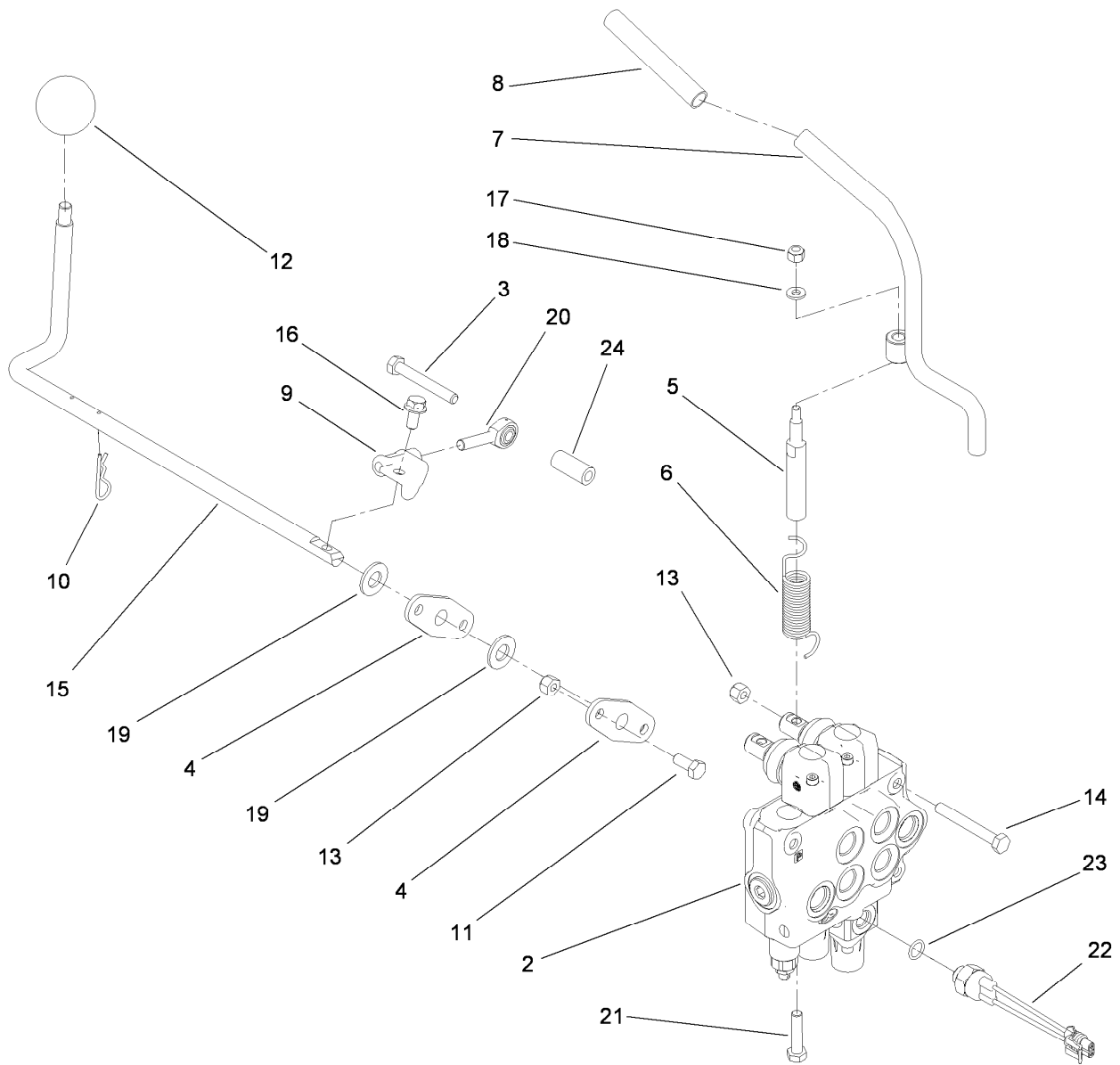

## Hydraulic Control Assembly

Ref.	Part Number	Qty.	Description
2	115-4062	1	HYD Valve ASM
3	33114-060	1	Screw-HH
4	20-1620	2	Bearing-Wheel, Friction
5	104-2827	1	Spacer-Hiflo
6	112-2738	1	Spring-Torsion
7	112-2739	1	Lever-Auxiliary
8	112-2605	1	Grip-Rubber
9	112-7210	1	Bracket-Control
10	3290-467	2	Pin-Hair
11	322-3	4	Screw-HH
12	233-21	1	Knob
13	3296-29	7	Nut-Lock, NI

Ref.	Part Number	Qty.	Description
14	322-12	3	Screw-HH
15	114-8598	1	Rod-Lever, Cylinder
16	3234-14	1	Screw-HHF
17	3296-42	1	Nut-Lock, NI
18	3256-16	1	Washer-Flat
19	3256-26	2	Washer-Flat
20	115-1273	1	Bearing-Rod End
21	48-7740	1	Screw
22	72-4310	1	Switch-Ball
23	237-42	1	O-Ring
24	103-0384	1	Spacer

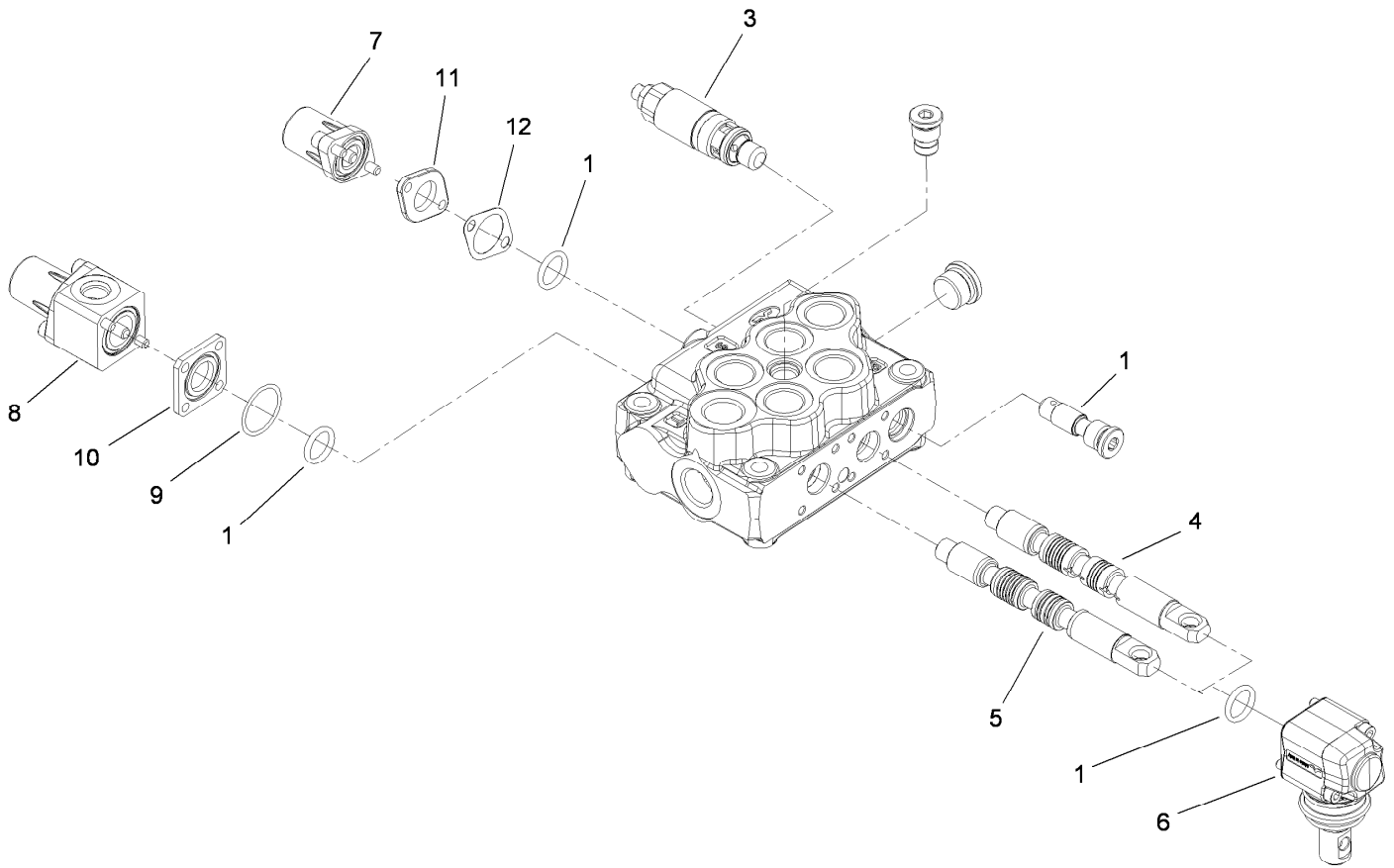

## 2-Spool Valve Assembly No. 115-4062

<i>Ref.</i>	<i>Part Number</i>	<i>Qty.</i>	<i>Description</i>
1	106-7719	4	Seal-Valve
3	100-8805	1	Valve-Relief
4	115-4084	1	Spool-Valve
5	106-7572	1	Spool
6	100-7229	2	Lever Kit
7	115-4092	1	Spring Return Kit
8	115-4093	1	Switch Spring Return Kit
9	115-4097	1	Seal-Return
10	115-4094	1	Spacer-Square
11	115-4089	1	Spacer-Spring Return
12	115-4088	1	Gasket-Return

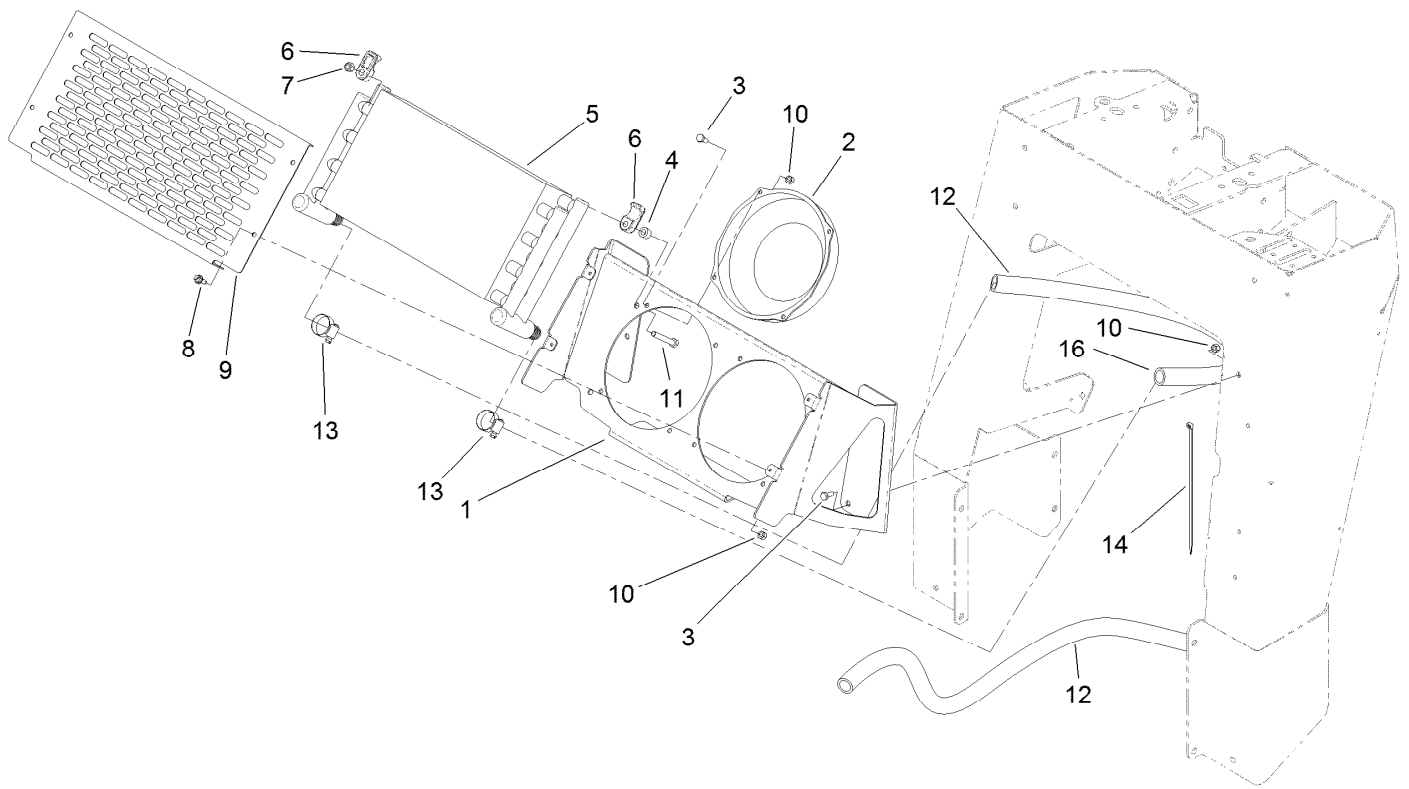

## Oil Cooler Assembly

<i>Ref.</i>	<i>Part Number</i>	<i>Qty.</i>	<i>Description</i>
1	115-9240-01	1	Mount-Cooler
2	120-7390	2	Fan
3	321-3	12	Screw-HH
4	98-4695	4	Spacer
5	117-6320	1	Cooler-Oil
6	105-3943	8	Clamp-Cooler, Oil
7	3296-29	4	Nut-Lock, NI
8	32104-95	4	Screw-HWH
9	119-4633-01	1	Cover-Cooler
10	3296-42	16	Nut-Lock, NI
11	322-11	4	Screw-HH
12	115-1207	1	Hose-Return
13	2412-129	2	Clamp-Hose
14	3334-945	1	Tie-Cable
16	117-3966	1	Hose-Cooler

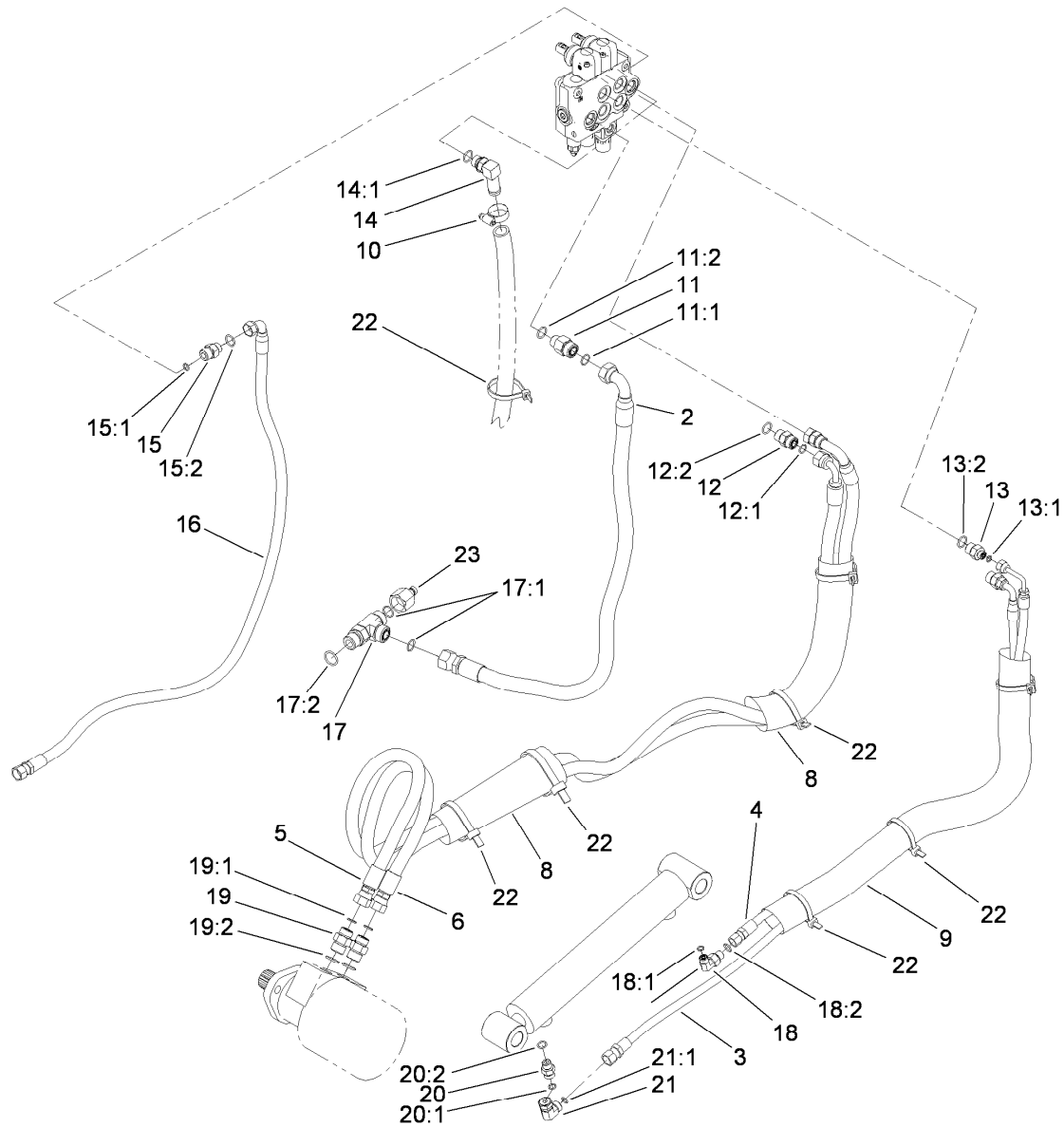

## Hydraulic Hose Routing Assembly

Ref.	Part Number	Qty.	Description	Ref.	Part Number	Qty.	Description
2	114-3043	1	Hose ASM	15:1	237-22	1	O-Ring
3	114-3044	1	Hose ASM	15:2	237-79	1	O-Ring
4	114-3045	1	Hose ASM	16	117-4038	1	Hose ASM
5	114-3046	1	Hose ASM	17	340-22	1	Fitting-HYD, Tee
6	114-3085	1	HYD Hose ASM	17:1	237-65	2	O-Ring
8	99-5648	2	Sleeve-Protective	17:2	237-80	1	O-Ring
9	115-4064	1	Sleeve-Protective	18	340-82	1	Adapter
10	2412-129	2	Clamp-Hose	18:1	237-42	1	O-Ring
11	340-155	1	Fitting-HYD, Straight	18:2	237-21	1	O-Ring
11:1	237-79	1	O-Ring	19	340-6	2	Fitting-HYD, Straight
11:2	237-151	1	O-Ring	19:1	237-30	1	O-Ring
12	340-4	2	Fitting-HYD, Straight	19:2	237-80	1	O-Ring
12:1	237-30	1	O-Ring	20	115-4081	1	Valve-Check
12:2	237-79	1	O-Ring	20:1	237-42	1	O-Ring
13	340-133	2	Adapter	20:2	237-22	1	O-Ring
13:1	237-79	1	O-Ring	21	340-159	1	Fitting-HYD, 90 DEG
13:2	237-21	1	O-Ring	21:1	237-22	2	O-Ring
14	353-954	1	Adapter	22	3334-945	9	Tie-Cable
14:1	237-79	1	O-Ring	23	86-5860	1	Nipple
15	340-3	1	Adapter				

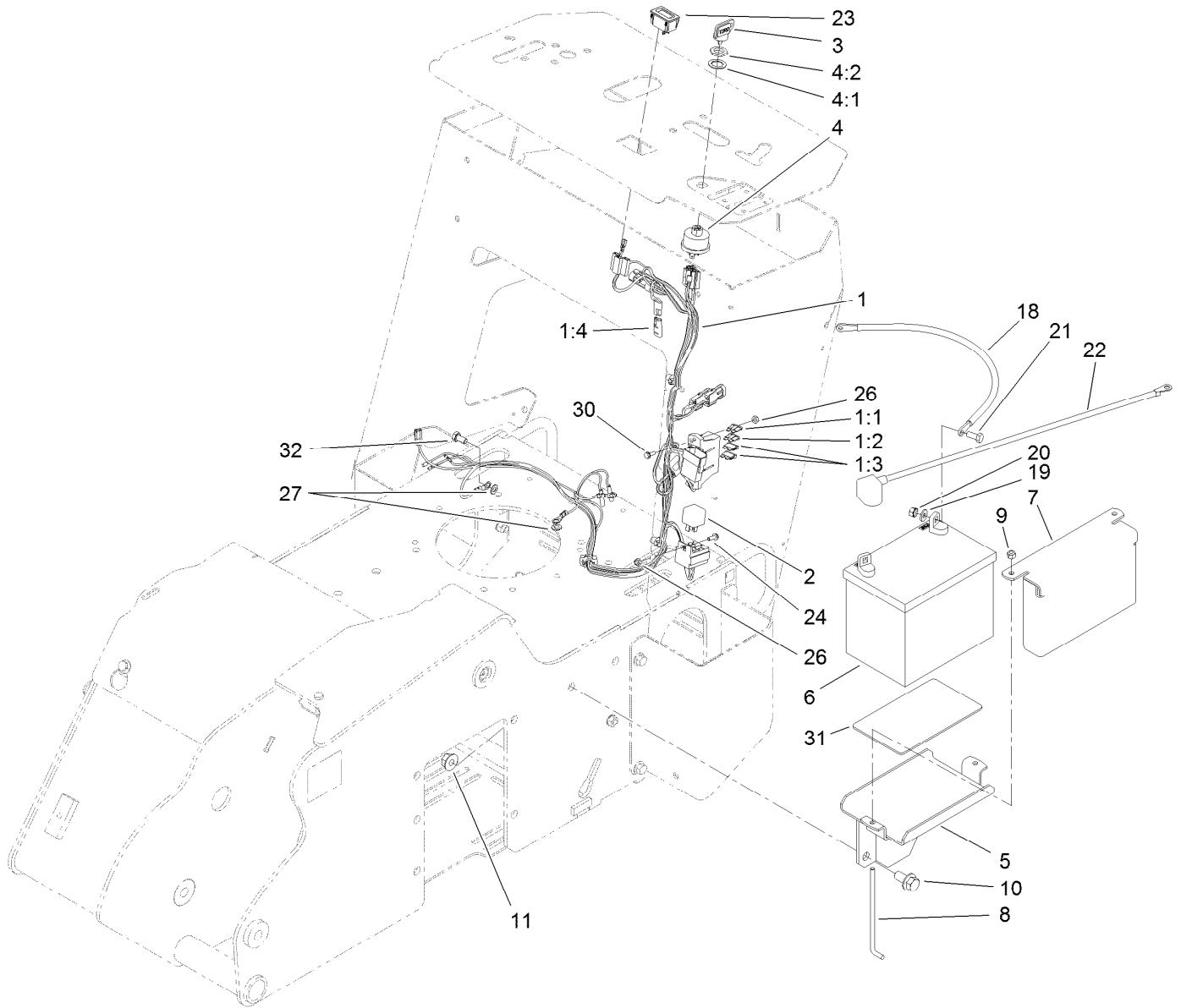

## Electrical Assembly

<i>Ref.</i>	<i>Part Number</i>	<i>Qty.</i>	<i>Description</i>	<i>Ref.</i>	<i>Part Number</i>	<i>Qty.</i>	<i>Description</i>
1	117-6338	1	Harness-Wire	10	3234-6	2	Screw-HHF
1:1	109103	1	Fuse-Blade, 30 Amp	11	32128-49	2	Nut-HHF
1:2	109102	1	Fuse-Blade, 25 Amp	18	106-8945	1	Cable-Battery, Positive
1:3	109101	1	Fuse-Blade, 20 Amp	19	3256-2	2	Washer-Flat
1:4	116-0053	1	Cap-Plug	20	32149-1	2	Nut-Keps
2	98-7249	2	Relay	21	322-3	2	Screw-HH
3	63-8360	1	Key-Ignition (W/Shield)	22	117-6422	1	Cable-Battery, Black
4	88-9830	1	Key Switch ASM	23	120-2244	1	Hourmeter
4:1	3254-5	1	Washer-Tooth, Internal	24	32105-23	1	Screw
4:2	218-461	1	Nut-HH	26	3296-2	2	Nut-Lock, NI
5	105-3150-01	1	Tray-Battery	27	3255-8	1	Washer-Lock
6	104-8162	1	Battery	30	32105-13	1	Screw-HWH
7	115-6621-03	1	Plate-Hold Down, Battery	31	62-4300	1	Pad-Skid, Anti
8	104-8567	2	Holdown-Battery	32	33114-016	1	Screw-HH
9	3296-42	2	Nut-Lock, NI				

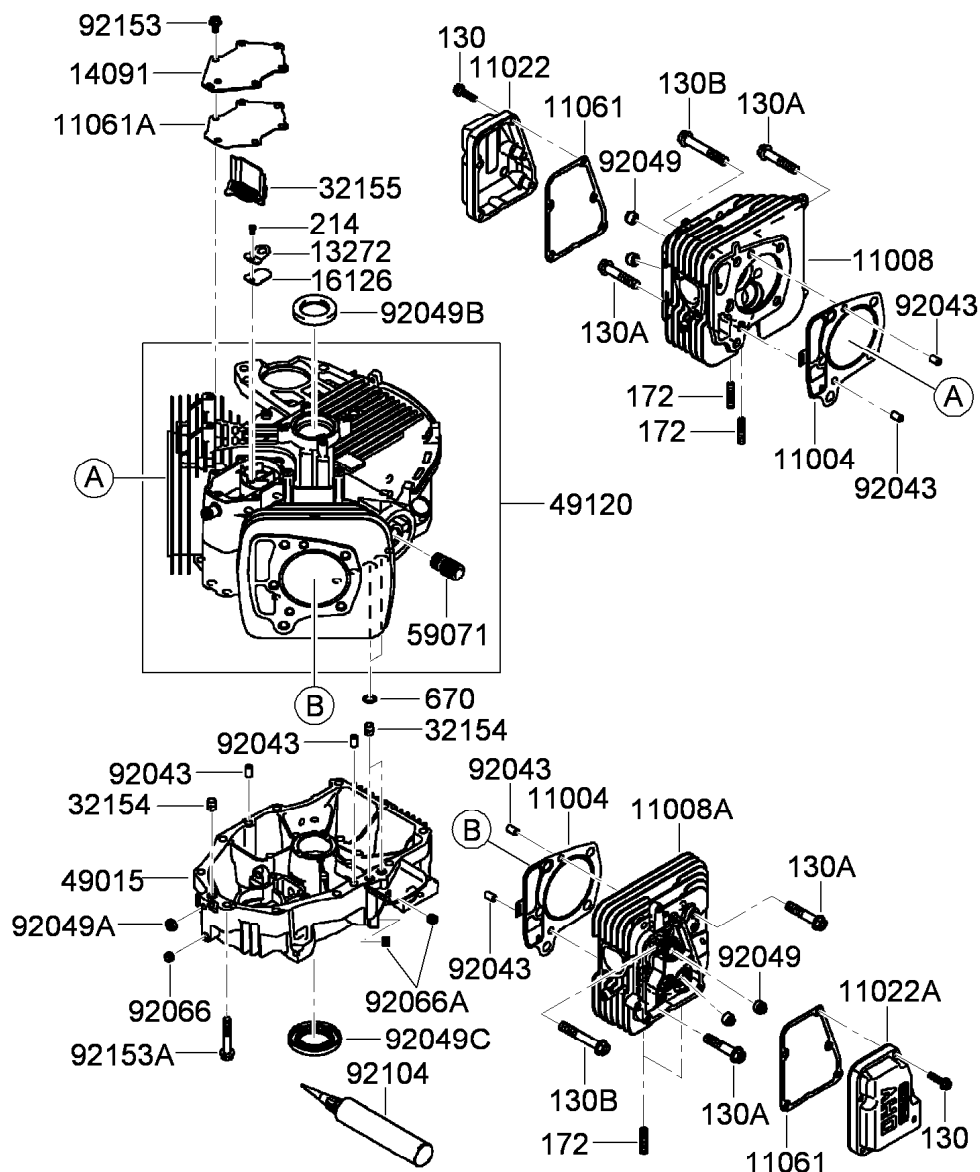

## Cylinder and Crankcase Assembly

Ref.	Part Number	Qty.	Description	Ref.	Part Number	Qty.	Description
130	93-8548	10	Bolt-Flanged (6X25)	32154	119-5811	3	Pipe
130A	119-5822	4	Bolt-Flanged (10X50)	32155	119-5812	1	Pipe-Breather
130B	119-5823	6	Bolt-Flanged (10X65)	49015	119-5813	1	Cover-Crankcase
172	114-8658	4	Bolt-Stud (8X18)	49120	119-5814	1	Crankcase ASM
214	115-6422	1	Screw-Pan (4X8)	59071	95-9715	1	Joint
670	95-9771	2	O-Ring (11Mm)	92043	KW10694	6	Pin
11004	119-5800	2	Gasket-Head	92049	114-8650	4	Seal-Oil, Rv C2 (6X11X10.2)
11008	119-5801	1	Head-Cylinder (No.1)	92049A	119-5816	1	Seal-Oil, So (8X14X5) Hs
11008A	119-5802	1	Head-Cylinder (No.2)	92049B	119-5817	1	Seal-Oil, Sd (35X48X8) R Hs
11022	119-5803	1	Case-Rocker (No.1)	92049C	119-5818	1	Seal-Oil (38X62X8) Mtclv
11022A	119-5804	1	Case-Rocker (No.2)	92066	119-5819	1	Plug
11061	119-5805	2	Gasket-Case, Rocker	92066A	119-5820	2	Plug
11061A	119-5806	1	Gasket-Breather	92104	119-5821	1	Gasket-Liquid (Tb1217H)
13272	119-5808	1	Plate-Breather	92153	114-8655	6	Bolt (6X12)
14091	119-5809	1	Cover-Breather	92153A	114-8656	10	Bolt (8X50)
16126	119-5810	1	Valve-Breather				



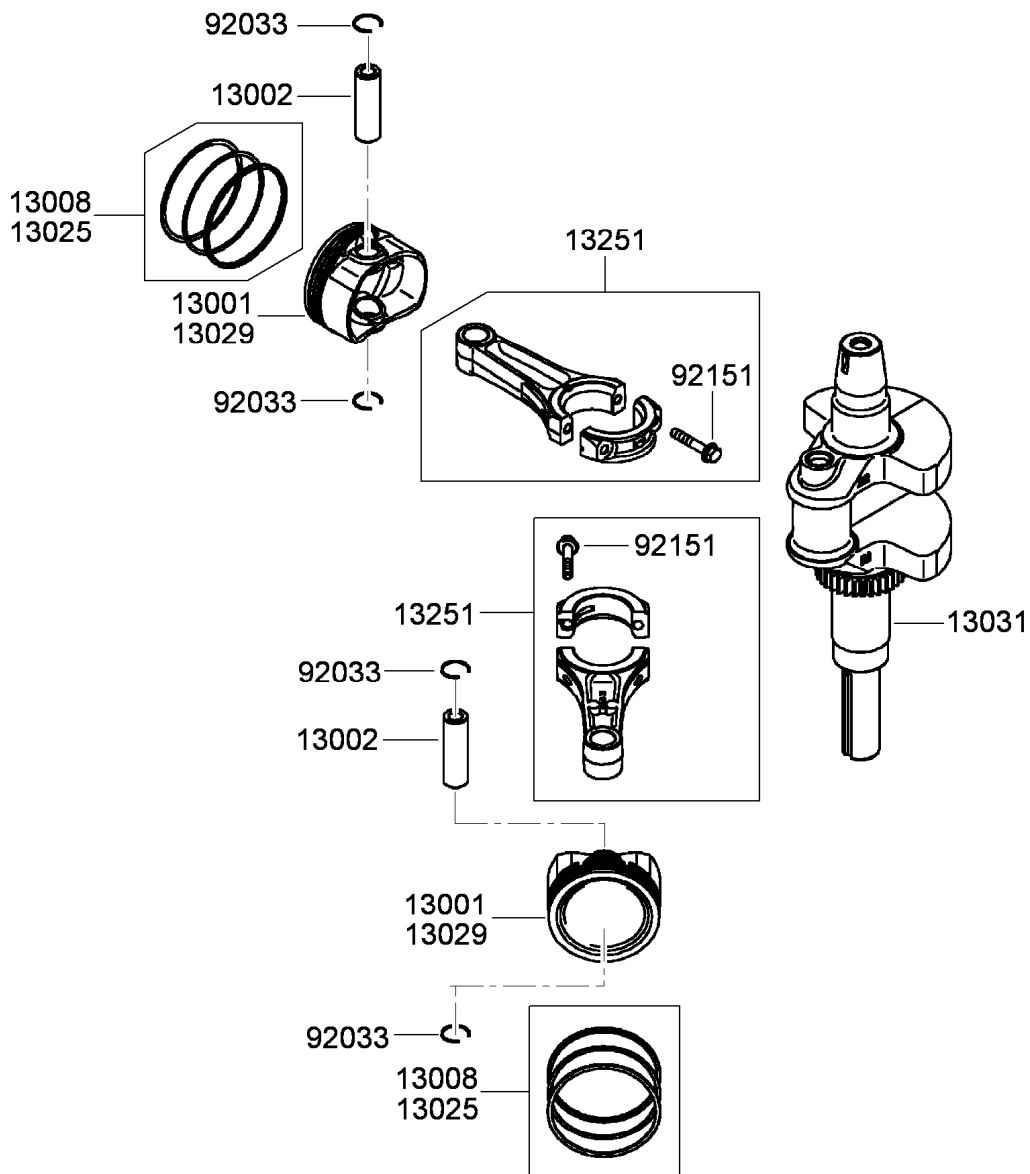

## Piston and Crankshaft Assembly

Ref.	Part Number	Qty.	Description
13001	119-5824	2	Piston-Engine
13002	119-5825	2	Pin-Piston
13008	119-5826	2	Piston Ring Set
13025	119-5827	1	Piston Ring Set, L (0.5)
13029	119-5828	1	Piston-Engine, L (0.5)
13031	119-5829	1	Crankshaft ASM
13251	119-5830	2	Connecting Rod ASM
92033	119-5831	4	Ring-Snap
92151	115-6565	4	Bolt (6X35)

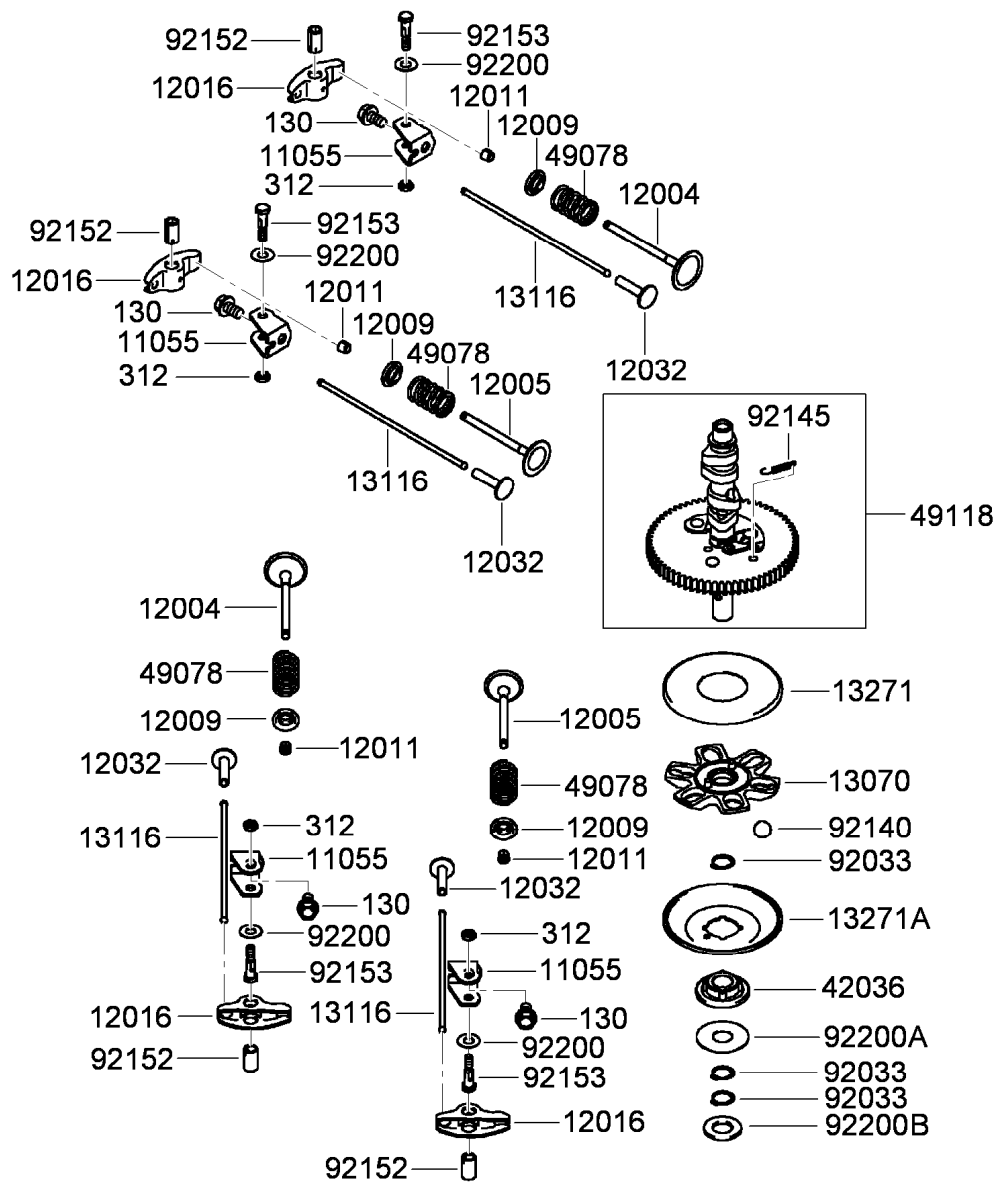

## Valve and Camshaft Assembly

Ref.	Part Number	Qty.	Description	Ref.	Part Number	Qty.	Description
130	119-5845	4	Bolt-Flanged (8X14)	13271A	114-8672	1	Plate-Governor
312	119-5846	4	Nut-Hex (6Mm)	42036	114-8673	1	Sleeve
11055	119-5832	4	Bracket	49078	119-5838	4	Spring-Valve, Engine (In)
12004	119-5833	2	Valve-Intake	49118	119-5839	1	Camshaft ASM
12005	119-5834	2	Valve-Exhaust	92033	114-8675	3	Ring-Snap
12009	108-2525	4	Retainer-Spring, Valve	92140	114-8676	6	Ball
12011	95-8744	8	Plate-Bedbar, Lower	92145	114-8677	1	Spring
12016	119-5835	4	Arm-Rocker	92152	119-5840	4	Collar
12032	108-2527	4	Tappet	92153	119-5841	4	Bolt (6X29.5)
13070	119-5836	1	Guide-Governor	92200	119-5842	4	Washer (8.1X18X0.5)
13116	119-5837	4	Rod-Push	92200A	119-5843	1	Washer (16X42X0.91)
13271	114-8671	1	Plate	92200B	119-5844	1	Washer (16.3X30X2.28)

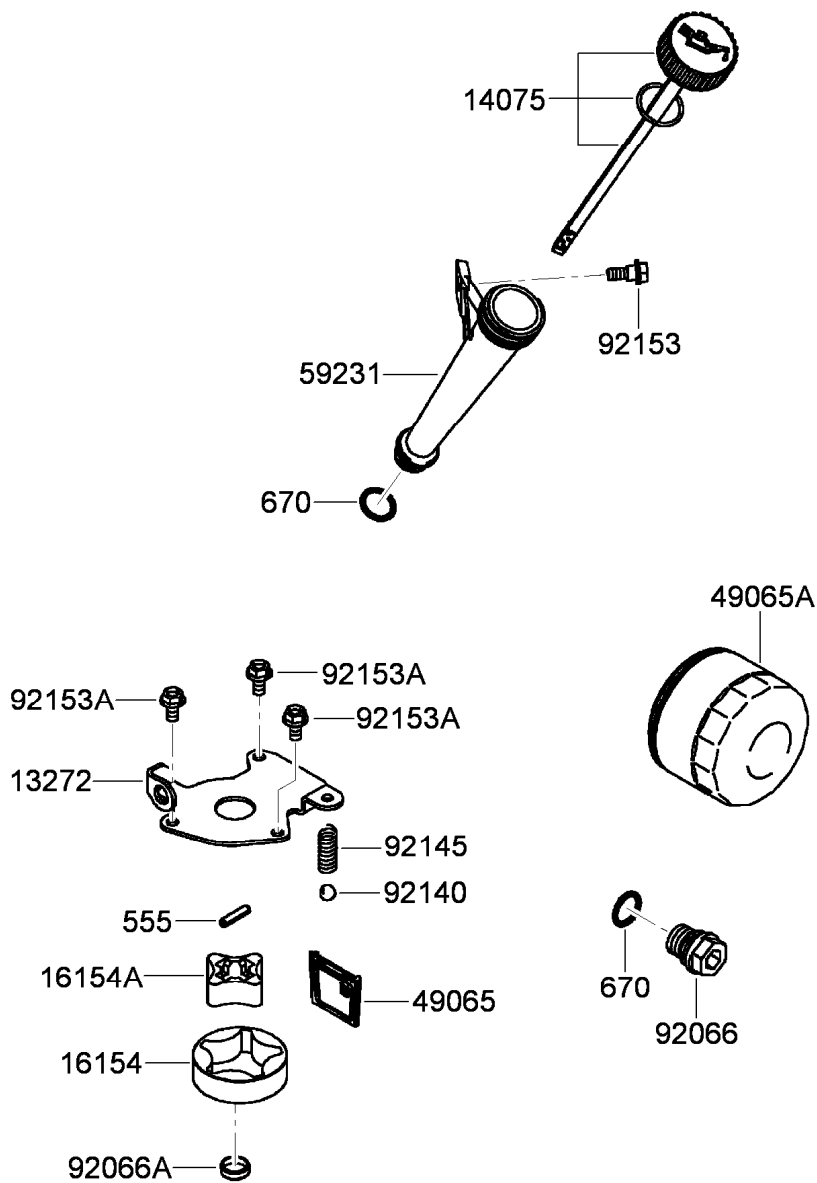

## Lubrication Equipment Assembly

Ref.	Part Number	Qty.	Description
555	119-5859	1	Pin-Spring (4X20)
670	1-413506	2	Discontinued
13272	119-5847	1	Plate-Rotor
14075	119-5848	1	Oil Gauge Cap ASM
16154	119-5849	1	Rotor-Pump, Outer
16154A	119-5850	1	Rotor-Pump, Inner
49065	119-5851	1	Filter-Oil
49065A	119-5852	1	Filter-Oil
59231	119-5853	1	Tube-Filler, Oil
92066	119-5854	1	Plug
92066A	119-5855	1	Plug
92140	119-5856	1	Ball
92145	119-5857	1	Spring
92153	119-5858	1	Bolt
92153A	115-6419	3	Bolt (6X12)

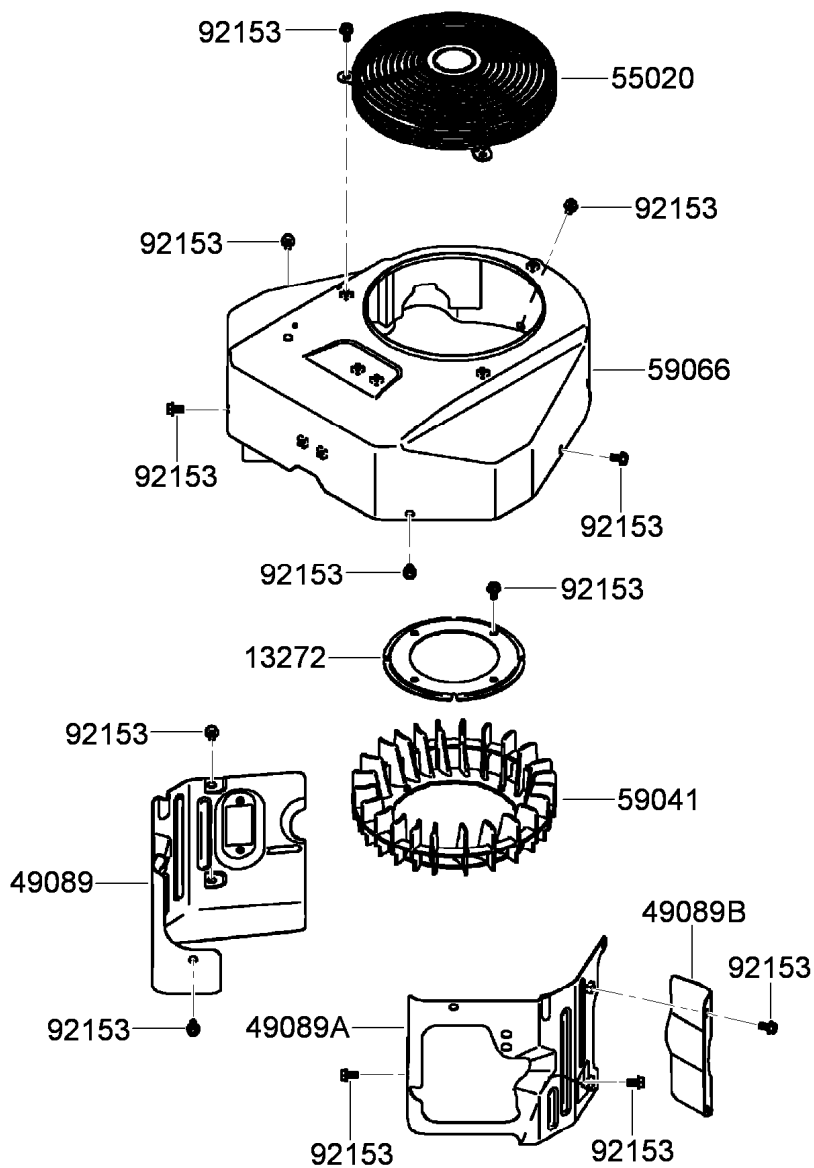

## Cooling Equipment Assembly

<i>Ref.</i>	<i>Part Number</i>	<i>Qty.</i>	<i>Description</i>
13272	119-5860	1	Plate-Fan
49089	119-5862	1	Shroud-Engine
49089A	119-5863	1	Shroud-Engine
49089B	119-5864	1	Shroud-Engine
55020	119-5865	1	Guard
59041	119-5867	1	Fan
59066	119-5868	1	Housing-Fan
92153	114-8655	18	Bolt (6X12)

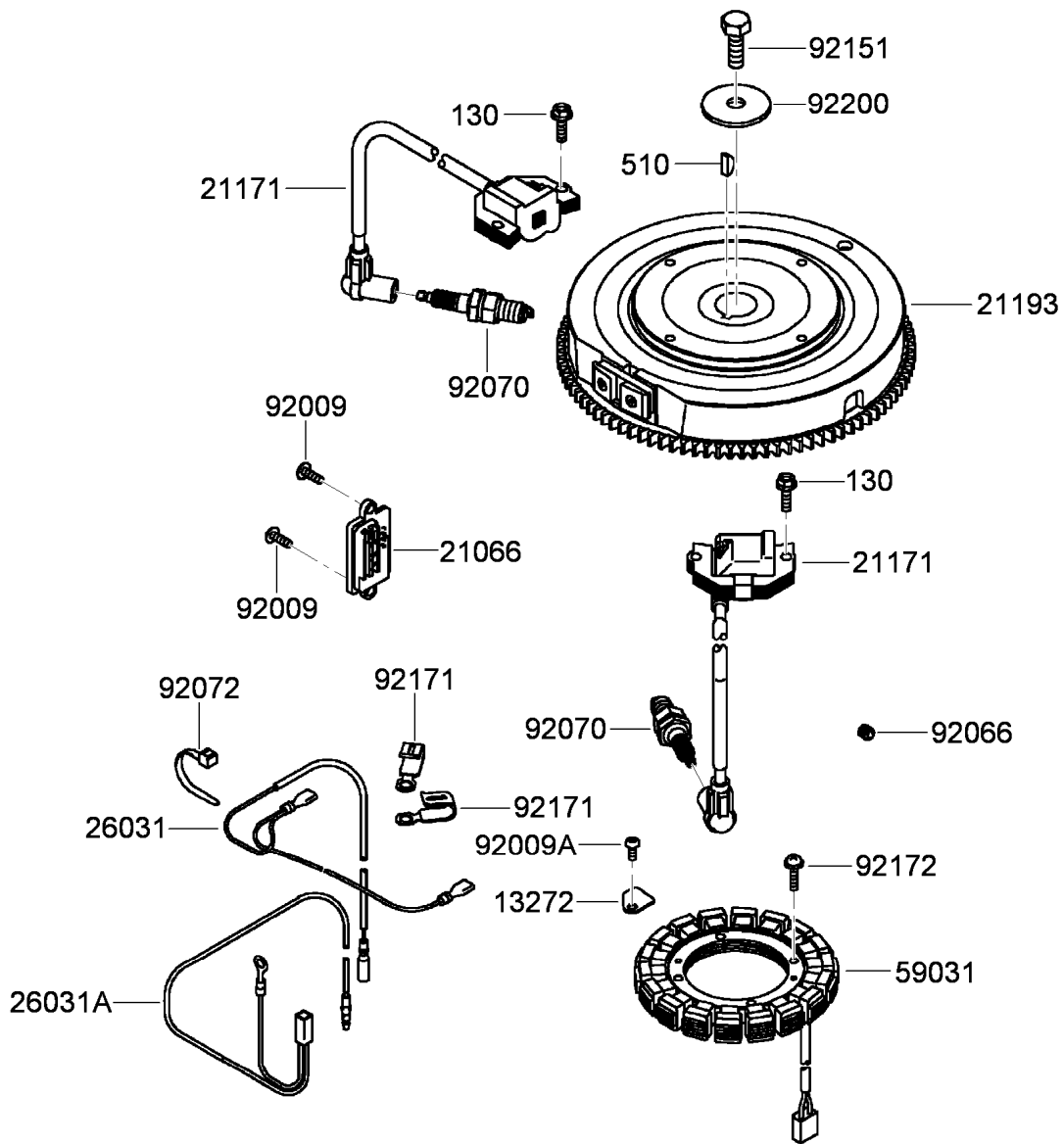

## Electric Equipment Assembly

<i>Ref.</i>	<i>Part Number</i>	<i>Qty.</i>	<i>Description</i>	<i>Ref.</i>	<i>Part Number</i>	<i>Qty.</i>	<i>Description</i>
130	95-9893	4	Bolt-Flanged (6X20)	92009	119-5879	2	Screw
510	KW10163	1	Key-Woodruff	92009A	95-9716	1	Screw
13272	119-5870	1	Plate	92066	119-5820	1	Plug
21066	120-7356	1	Regulator-Voltage	92070	92-2153	2	Spark Plug
21171	119-5872	2	Ignition Coil ASM	92072	115-6585	1	Band
21193	119-5874	1	Flywheel ASM	92151	115-6408	1	Bolt (12X30)
26031	119-5876	1	Harness	92171	115-8665	2	Clamp
26031A	119-5877	1	Harness	92172	115-4030	4	Screw (5X20)
59031	120-7355	1	Coil-Charging	92200	115-4031	1	Washer (12.2X46X3)

# Carburetor Assembly

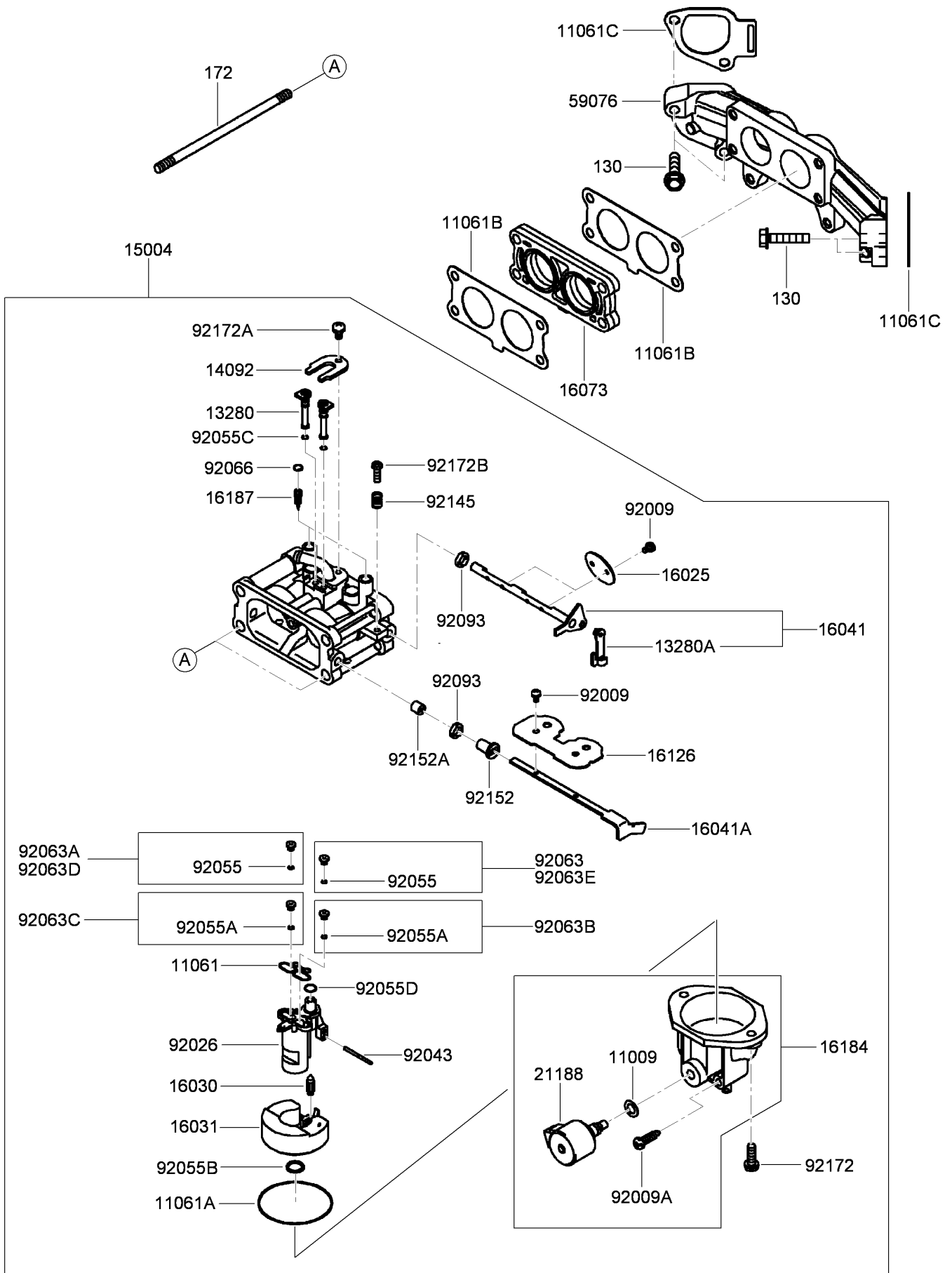

## Carburetor Assembly (continued)

<i>Ref.</i>	<i>Part Number</i>	<i>Qty.</i>	<i>Description</i>	<i>Ref.</i>	<i>Part Number</i>	<i>Qty.</i>	<i>Description</i>
130	119-5940	4	Bolt-Flanged (6X30)	92009A	119-5917	1	Screw-Drain
172	119-5941	2	Bolt-Stud (6X115)	92026	119-5918	1	Spacer
11009	119-5895	1	Gasket	92043	119-5919	1	Pin-Float
11061	119-5896	1	Gasket	92055	119-5920	1	O-Ring
11061A	119-5897	1	Gasket	92055A	119-5921	2	O-Ring
11061B	119-5898	2	Gasket-Carburetor/Manifold	92055B	119-5921	1	O-Ring
11061C	119-5899	2	Gasket-Manifold	92055C	119-5923	2	O-Ring
13280	119-5901	2	Holder	92055D	119-5924	1	O-Ring
13280A	119-5902	1	Holder	92063	119-5926	1	Jet-Main (No. 108)
14092	119-5903	1	Cover	92063A	119-5927	1	Jet-Main (No. 104)
15004	119-5904	1	Carburetor ASM	92063B	119-5928	1	Jet-Main (No. 114)
16025	119-5905	2	Valve-Throttle	92063C	119-5929	1	Jet-Main (No. 110)
16030	119-5906	1	Valve-Float	92063D	119-5930	1	Jet-Main (No. 107)
16031	119-5907	1	Float	92063E	119-5931	1	Jet-Main (No. 111)
16041	119-5908	1	Carburetor Throttle Shaft ASM	92066	119-5932	2	Plug-Expansion
16041A	119-5909	1	Shaft-Choke, Carburetor	92093	119-5933	2	Seal (6.9)
16073	119-5910	1	Insulator	92145	119-5934	1	Spring
16126	119-5911	1	Valve	92152	119-5935	1	Collar
16184	119-5912	1	Float Chamber ASM	92152A	119-5936	1	Collar
16187	119-5913	2	Needle-Jet	92172	119-5937	2	Screw (M5)
21188	119-5914	1	Solenoid	92172A	119-5938	1	Screw (M4)
59076	119-5915	1	Manifold-Intake	92172B	119-5939	1	Screw-Adjust, Throttle
92009	119-5916	6	Screw				

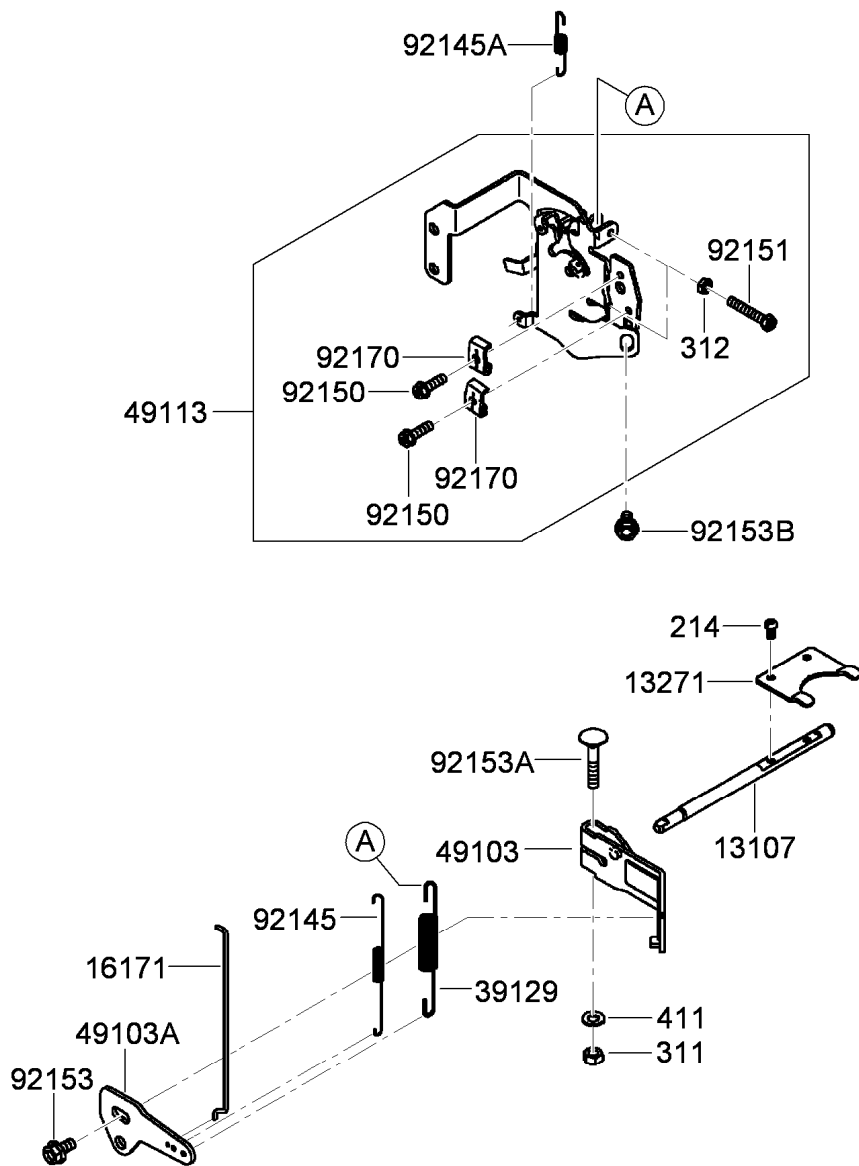

## Control Equipment Assembly

<i>Ref.</i>	<i>Part Number</i>	<i>Qty.</i>	<i>Description</i>	<i>Ref.</i>	<i>Part Number</i>	<i>Qty.</i>	<i>Description</i>
214	115-6422	2	Screw-Pan (4X8)	49113	119-5888	1	Control Panel ASM
311	114-8698	1	Nut-Hex (6Mm)	92145	119-5889	1	Spring
312	119-5894	2	Nut-Hex (5Mm)	92145A	119-5890	1	Spring
411	115-6423	1	Washer-Plain (6Mm)	92150	95-9853	2	Bolt (5X18)
13107	119-5882	1	Shaft-Governor	92151	119-5891	2	Bolt (5X30)
13271	119-5883	1	Plate	92153	119-5892	1	Bolt (6X12)
16171	119-5884	1	Link	92153A	115-6420	1	Bolt (6X35)
39129	119-5885	1	Spring-Governor	92153B	119-5892	1	Bolt (6X12)
49103	119-5886	1	Arm-Governor	92170	115-6421	2	Clamp
49103A	119-5887	1	Arm-Governor				



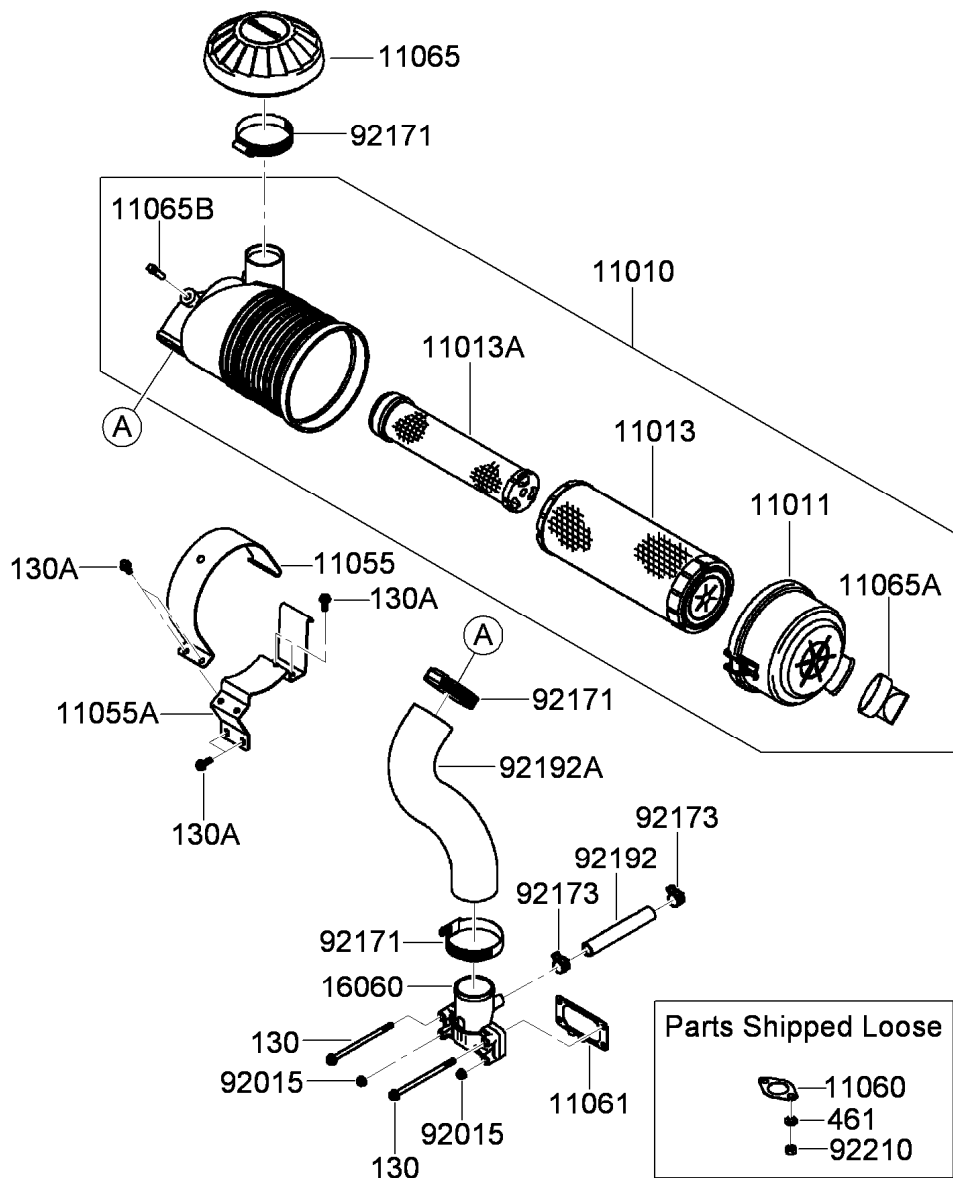

## Air Filter and Muffler Assembly

Ref.	Part Number	Qty.	Description	Ref.	Part Number	Qty.	Description
130	119-5960	2	Bolt-Flanged (6X110)	11065	119-5950	1	Cap
130A	119-5961	6	Bolt-Flanged (6X16)	11065A	119-5951	1	Cap
461	119-5962	4	Washer-Spring (8Mm)	11065B	119-5952	1	Cap
11010	119-5942	1	Air Filter ASM	16060	119-5953	1	Pipe-Intake
11011	119-5943	1	Case-Filter, Air	92015	119-5954	2	Nut
11013	119-5944	1	Element-Filter, Air	92171	119-5955	3	Clamp
11013A	119-5945	1	Element-Filter, Air	92173	119-5956	2	Clamp
11055	119-5946	1	Bracket	92192	119-5957	1	Tube (12.6X18.6X118)
11055A	119-5947	1	Bracket	92192A	119-5958	1	Tube
11060	119-5948	2	Gasket-Muffler	92210	119-5959	4	Nut (M8)
11061	119-5949	1	Gasket				

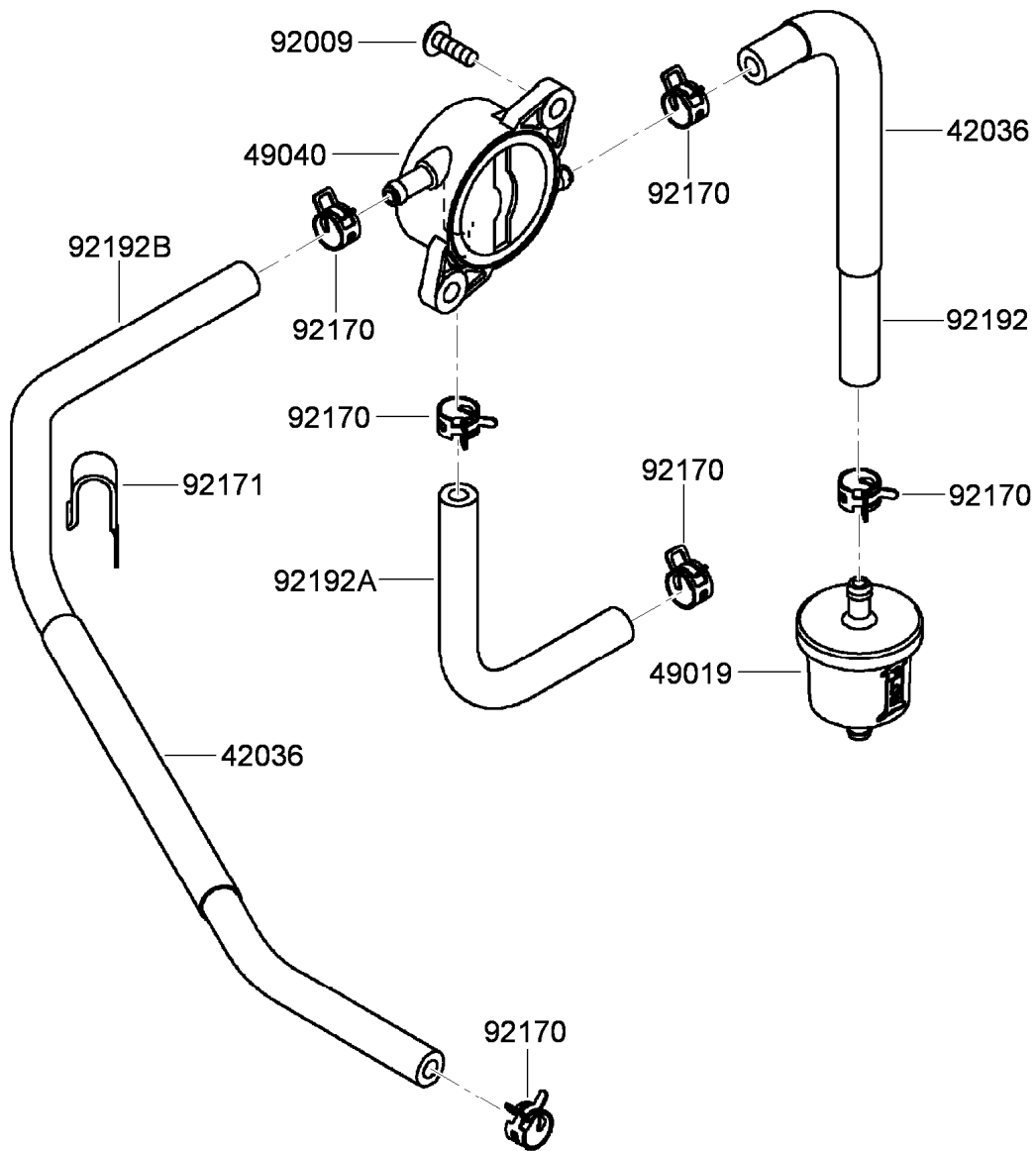

## Fuel Tank and Valve Assembly

<i>Ref.</i>	<i>Part Number</i>	<i>Qty.</i>	<i>Description</i>
42036	119-5963	2	Sleeve
49019	121-4570	1	Filter-Fuel
49040	119-5965	1	Pump-Fuel
92009	119-5879	2	Screw
92170	119-5967	6	Clamp
92171	119-5968	1	Clamp
92192	119-5969	1	Tube (6.35X12.7X185)
92192A	119-5970	1	Tube (6.4X12.7X150)
92192B	119-5971	1	Tube (6.35X12.7X390)

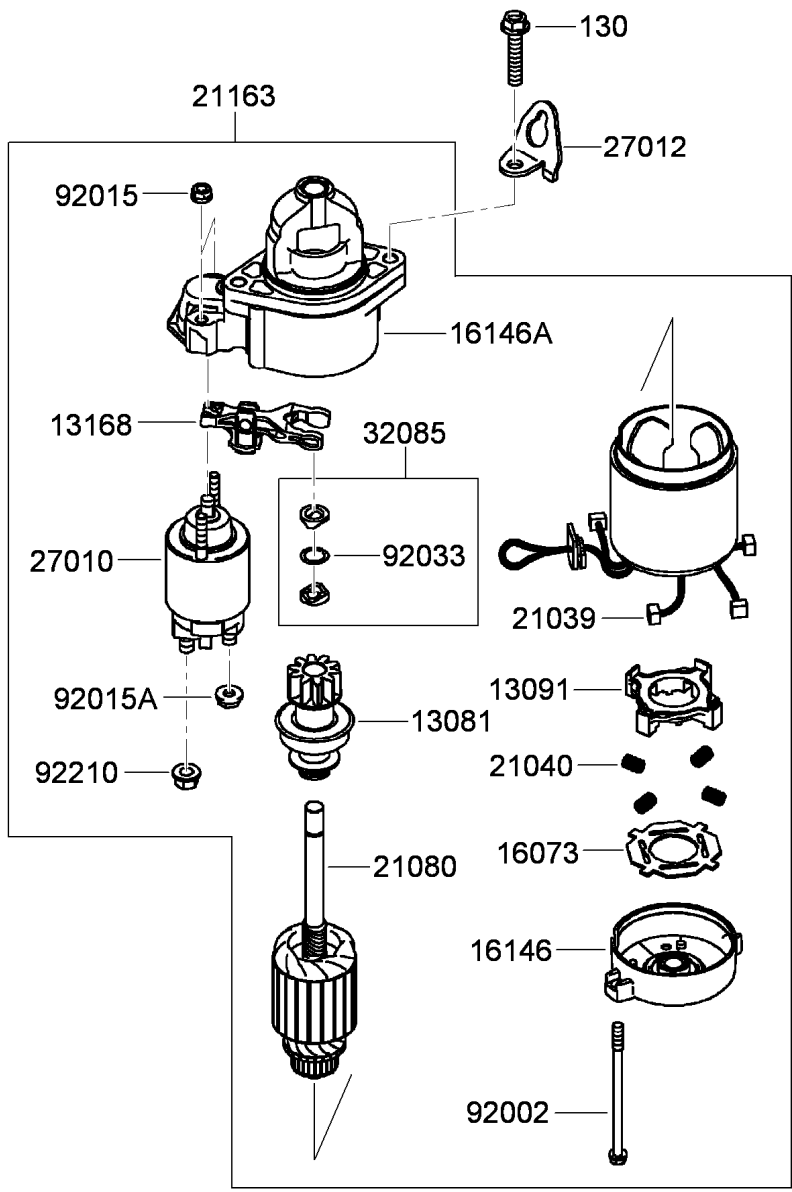

## Starter Assembly

Ref.	Part Number	Qty.	Description
130	119-5991	2	Bolt-Flanged (8X40)
13081	119-5972	1	Clutch ASM
13091	119-5973	1	Holder-Brush
13168	119-5974	1	Lever-Shift
16073	119-5975	1	Insulator
16146	119-5976	1	Cover ASM
16146A	119-5977	1	Cover ASM
21039	119-5978	4	Brush
21040	119-5979	4	Spring-Brush
21080	119-5980	1	Armature

Ref.	Part Number	Qty.	Description
21163	119-5981	1	Starter-Electric
27010	119-5982	1	Switch
27012	119-5983	1	Hook
32085	119-5985	1	Stopper
92002	119-5986	2	Bolt
92015	119-5987	2	Nut
92015A	119-5988	1	Nut
92033	119-5989	1	Ring-Snap
92210	119-5990	1	Nut

56014



56070

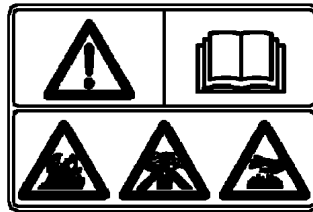

## Label Set

<i>Ref.</i>	<i>Part Number</i>	<i>Qty.</i>	<i>Description</i>
56014	119-5992	1	Emblem
56070	115-6469	1	Label-Warning

# Attachments and Accessories

## For 22974 TRX-26 Trencher

<b>Product Name</b>	<b>Model/Part</b>
8in Chain Conversion Kit for 36in Soil Chain .....	117-3480
Crumber Kit .....	22477
24in X 4in Soil Chain .....	22480
24in X 4in Combination Chain .....	22481
24in X 4in Rock Tooth Chain .....	22482
24in X 6in Soil Chain .....	22483
24in X 6in Combination Chain .....	22484
24in X 6in Rock Tooth Chain .....	22485
36in X 4in Soil Chain .....	22486
36in X 4in Combination Chain .....	22487
36in X 4in Rock Tooth Chain .....	22488
36in X 6in Rock Tooth Chain .....	22489
36in X 6in Soil Chain .....	22490
36in X 6in Combination Chain .....	22491
48in x 4in Soil Chain .....	22492
48in x 4in Combination Chain .....	22493
48in x 6in Soil Chain .....	22494
48in x 6in Combination Chain .....	22495
24in Trencher Boom .....	22975
36in Trencher Boom .....	22976
48in Trencher Boom .....	22977
Backfill Blade .....	22980
Spark Arrestor Screen .....	94-8157

**Notes:**

**Notes:**



**Count on it.**