



Commercial Products

**Hydraulics
Hydrostatics
Schematics
and Test
Equipment**

Introduction

Turf mowing equipment was very cumbersome and inefficient when it was first developed back in the early 1900's.

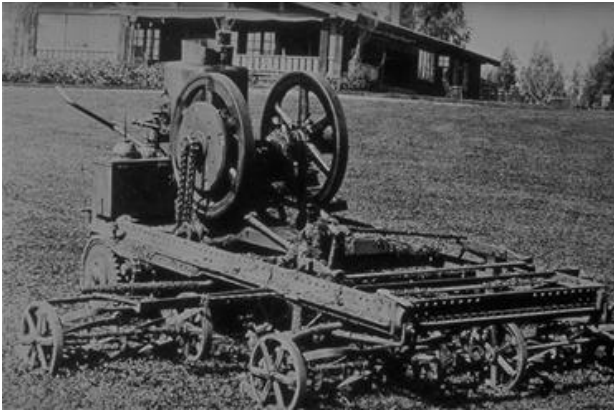

Improvements were made through the years of Turf equipment's development, but it wasn't until hydraulics became a part of the design that significant improvements were made.



Use of hydraulics has increased to form a major portion of turf product designs. Increases efficiency, reliability, lowered maintenance costs, safer products and improved operator comfort are all by-products of the increase in use of hydraulic systems on turf products.



An understanding of hydraulic systems and their function on a product, is a necessity to properly service, adjust, troubleshoot or test turf products.

INDEX

1: HYDRAULIC PRINCIPLES, PAGE 2.

OBJECTIVE: To familiarize the technician with the basic fundamentals of hydraulic systems and their operation.

2: HYDRAULIC SCHEMATICS, PAGE 7.

OBJECTIVE: Improve hydraulic technicians ability to read and comprehend hydraulic schematics, and apply them to various repair jobs.

3: HYDROSTATIC TRANSMISSIONS, PAGE 14.

OBJECTIVE: Provide technicians with helpful information on the operation and maintenance of hydrostatic transmissions.

4: HYDRAULIC HOSES AND FITTINGS, PAGE 19.

OBJECTIVE: Review proper hose and fitting service procedures.

5: TEST EQUIPMENT, PAGE 23.

OBJECTIVE: Instruct technicians on the proper test equipment and procedures to effectively and safely diagnose hydraulic systems.

6: REVIEW QUESTIONS, PAGE 27.

Review Answers

1 - A.	6 - B.	11 - B.	16 - B.
2 - B.	7 - D.	12 - F.	17 - B.
3 - B.	8 - A.	13 - A.	18 - D.
4 - A.	9 - C.	14 - A.	19 - D.
5 - B.	10 - B.	15 - C.	20 - B.

Principles of Hydraulic Circuits and Components



Figure 1

A hydraulic circuit, whether it is simple or complex, uses the following basic hydraulic principles:

1. A liquid can assume any shape and be bi-directional without affecting its free flow movement (Fig 2)

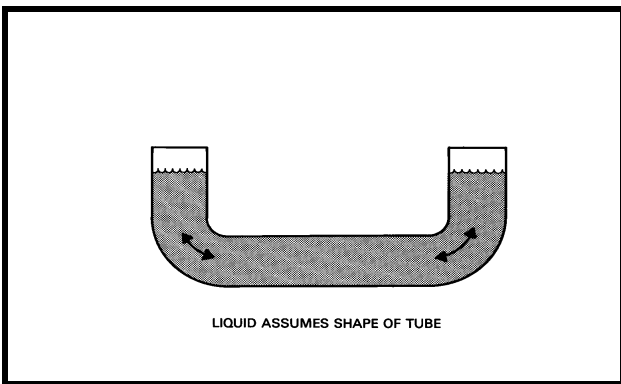

Figure 1

2. Pascal's law states that when a confined fluid is placed under pressure, the pressure is transmitted equally in all directions and on all faces of the container. This is the principle used to extend the ram on a hydraulic cylinder (Fig 3)

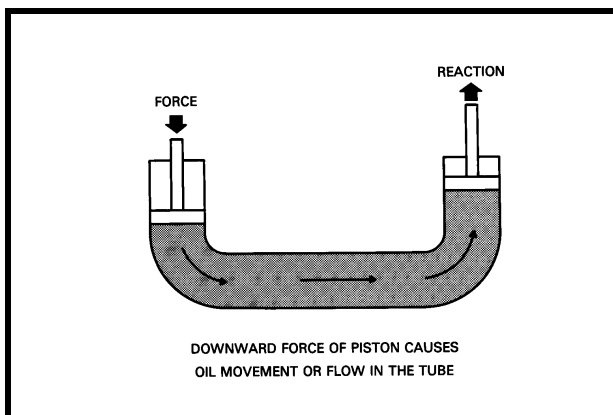

Figure 3

3. By making the containers or cylinders of different sizes, the mechanical advantage in work force increases (Fig. 4)

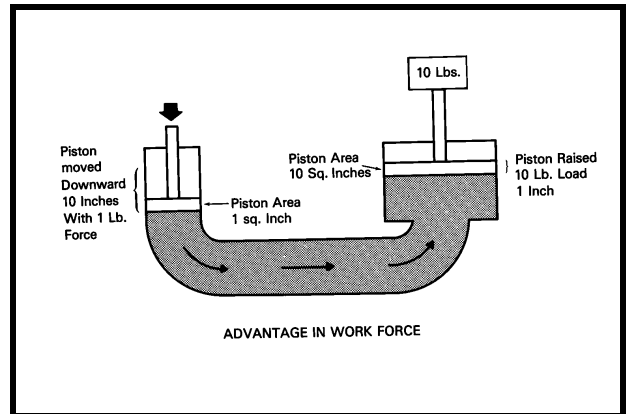

Figure 4

Basic Hydraulic Circuits and Components Used in Turf Equipment.

Although hydraulic circuit layouts may vary significantly in different applications, many of the components are similar in design or function. The principle behind most hydraulic systems is similar to that of the basic hydraulic jack. Oil from the reservoir is drawn past a check ball into the piston type pump during the pistons up-stroke (Fig 5)

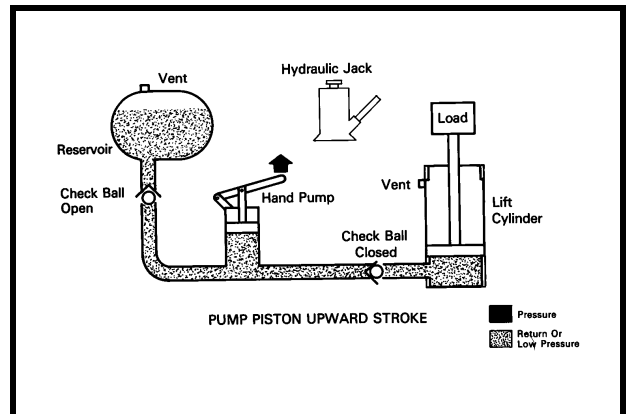

Figure 5

When the piston in the pump is pushed downward, oil will be directed past a second check ball into the cylinder. As the pump is actuated up and down, the incoming oil will cause the cylinder ram to extend. The lift cylinder will hold its extended position because the check ball is being seated by the pressure against it from the load side of the cylinder. The cylinder will return to neutral by unseating or bypassing the check balls, allowing the oil in the cylinder to return back to the reservoir (Fig.6)

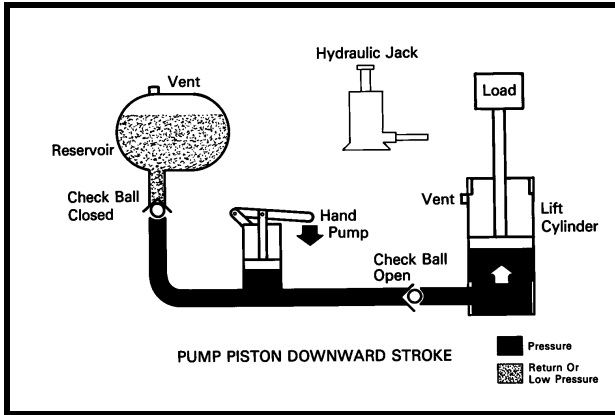

Figure 6

Because the pump displacement is usually much smaller than the cylinder, each stroke of the pump will move the cylinder a very small amount. If the cylinder is required to move at a faster rate, the surface area of the pump piston must be increased and/or the rate which the pump is actuated must be increased. OIL FLOW GIVES THE CYLINDER RAM ITS SPEED OF MOVEMENT AND OIL PRESSURE CREATES WORK FORCE.

We can improve the efficiency and increase the versatility of a basic circuit by adding some sophisticated components and changing the circuit layout. By incorporating a gear pump in place of a hand piston pump, we increase oil flow to the cylinder which will increase the actuation rate of the ram.

The most common type of pump is the gear pump (Fig 7). As the gears in the pump rotate, suction is created at the inlet port of the pump. The fluid is drawn in to the pump and is carried in the spaces between the gear teeth to the discharge port of the pump. At the discharge side of the pump the gear teeth mesh together and the oil is discharged from the pump.

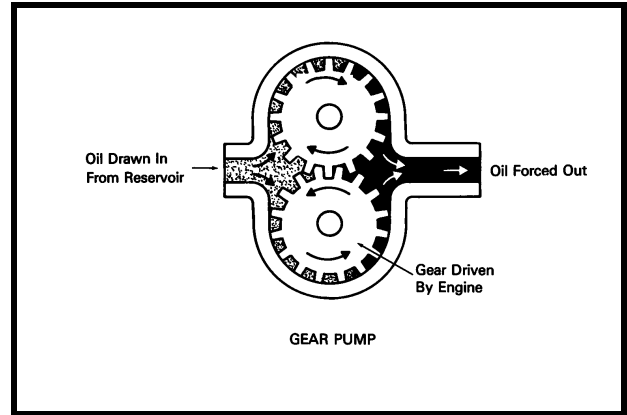

Figure 7

Below is a cutaway view of an actual three section pump.



Figure 8

The flow from the pump to the cylinder is controlled by a sliding spool valve which can be actuated by an electric solenoid, or a hand or foot operated lever. The valve shown in Figure 9 is an open center valve, meaning that the oil flow is returned to the reservoir when the valve is in the neutral position. If the oil flow is stopped in the neutral position than the valve is a closed center valve.

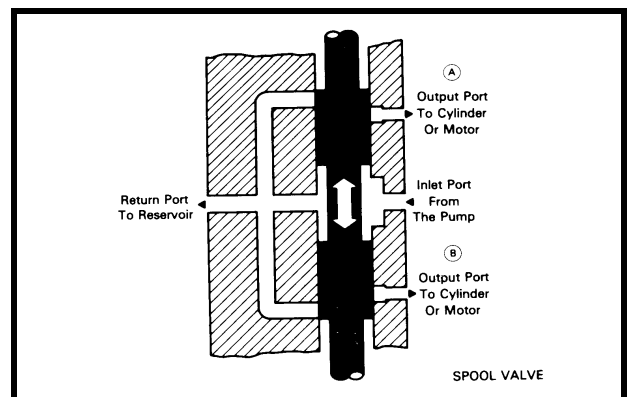

Figure 9

Below is a cutaway of an actual hydraulic control valve (Fig 10).

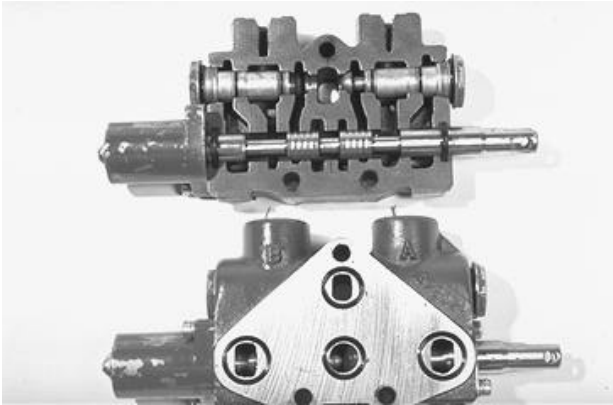

Figure 10

Here we see have a spool valve in our simple hydraulic system, we can see that the valve is in the neutral position and all the flow from the pump is directed back to the reservoir.

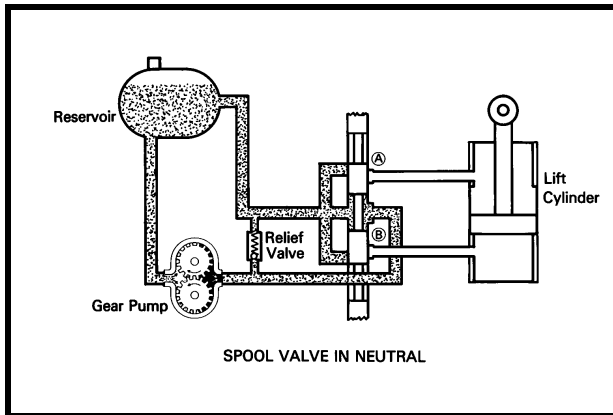

Figure 11

If the spool is moved upward, the oil flow from the pump is directed through the spool to one end of the lift cylinder. The oil in the opposite end of the cylinder is pushed out as the ram extends, and will pass through the spool and return to the reservoir.(Fig 12).

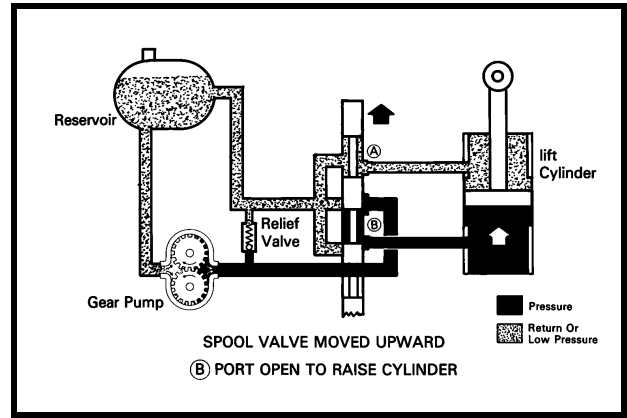

Figure 12

Since the fluid from a positive displacement pump must flow continuously whenever the pump is running it must have some where to go if not being used by the actuators. If the load on the cylinder becomes too great or if the ram bottoms out, the flow from the pump will be directed past the relief valve returning to the reservoir (Fig 13).

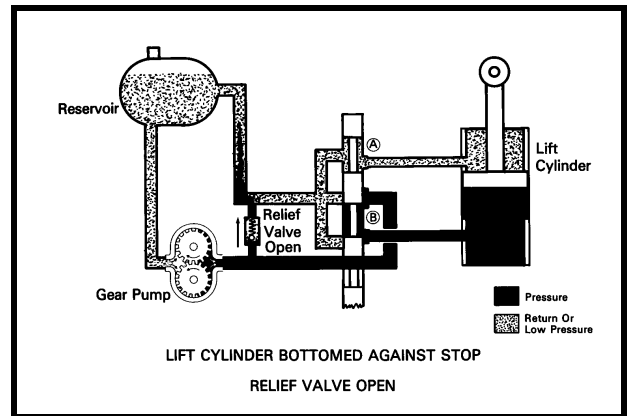

Figure 13

Substituting the lift cylinder with a gear motor, we can now utilize our basic circuit to create rotational movement to drive attachments (Fig 14).

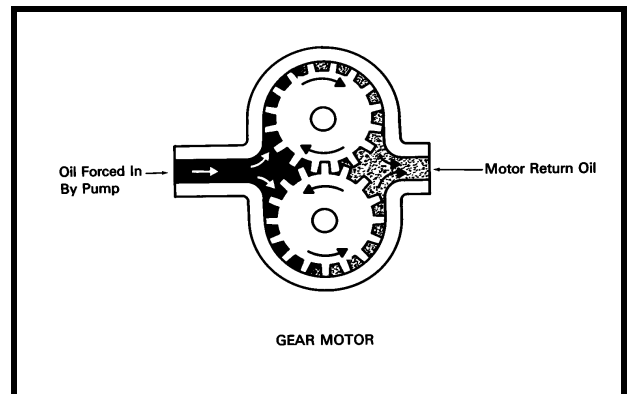

Figure 14

Figure 15 shows a hydraulic reel motor.

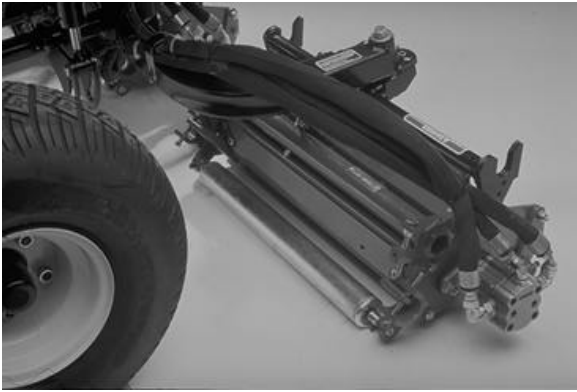

Figure 15

Figure 16 illustrates the basic circuit and components necessary to drive the reel cutting units. With the spool in the upward position, the oil flow is directed through the spool valve to the lower port driving the motor in the forward direction.

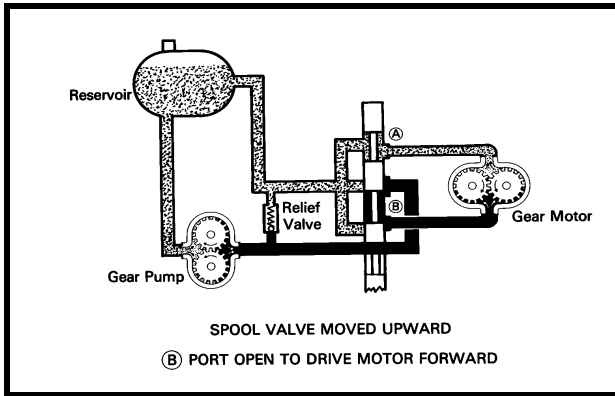

Figure 16

Actuating the spool to the down position, the flow of oil from the pump is directed to the opposite port of the motor. The motor then rotates in the reverse direction (Fig 17).

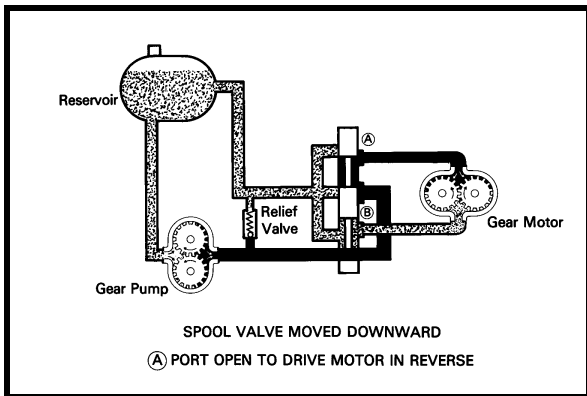

Figure 17

Another type of valve system becoming popular in turf equipment is the electric solenoid type valve system. The solenoid valve system consists of a machined valve body. This valve body contains the

solenoid valves and the internal porting to make the valve operate (Fig 18). The outer ports on the valve body are threaded to allow hoses and lines to be connected to the valve body. Care should be taken when tightening the hose and line fittings so the valve is not distorted by over tightening of the connections. Tighten the line and hose connections to the correct Flats From Finger Tight (F.F.F.T.) spec. listed in the service manual.



Figure 18

The electric solenoid valve operates by supplying electrical current to a coil magnet, the magnetic field moves a valve spool and this directs the oil. The thing to remember is that the only difference between a hydraulic/electric valve, and a regular hydraulic valve is the way that the spool is moved.

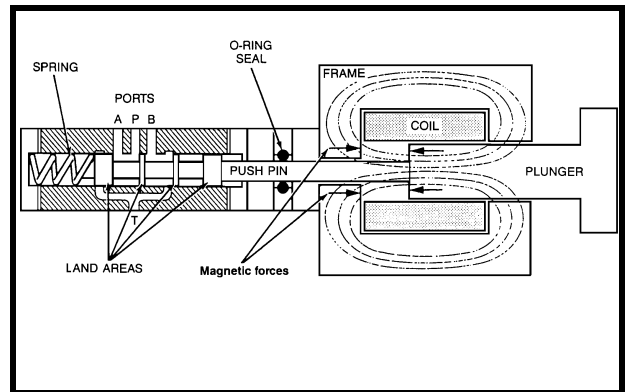

Figure 19

The solenoid valves consist of the valve cartridge and the solenoid coil (Fig 19). To disassemble the valve remove the coil assembly and then carefully unscrew the valve body. The O-rings and seals should be replaced whenever a valve body is removed or replaced.

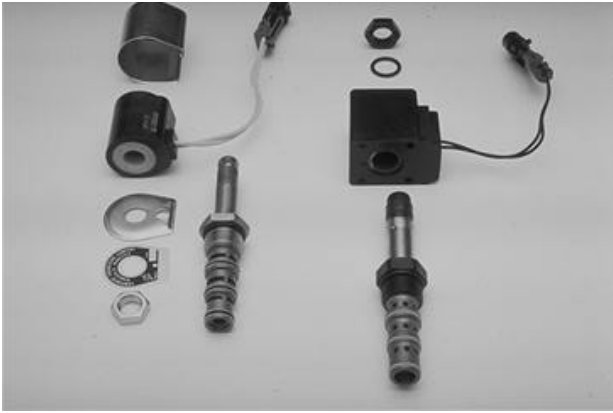

Figure 20

Inside the cartridge valve there is the valve spool, the armature and the armature spring. The manufacturing tolerances are extremely close and great care should be used when cleaning this type of valve. Cartridge valves used in most Toro equipment should not be disassembled. Figure 20 is for illustrative purposes only. The best way to clean the cartridge valve is to submerge the valve in clean mineral sprits and use a probe to push the internal spool in and out 20 to 30 times to flush out the contamination. Mineral sprits does not affect the O-ring material.



Figure 21

Understanding the basic hydraulic systems and components can be of great value when troubleshooting and testing hydraulic equipment. Most hydraulic systems will be similar to one of these two basic systems (Fig 22).

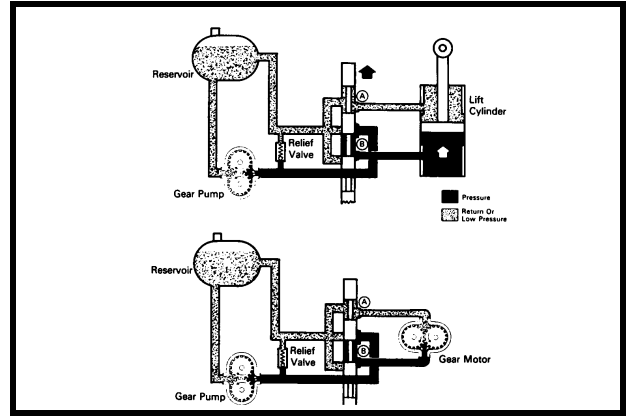

Figure 22

Figure 23 shows the actual hydraulic circuit for a Greensmaster 3000. This circuit and components are used to drive the unit in the No.1 traction position. When the engine is started, the pump draws oil from the reservoir through the suction lines. Oil from the No.4 section of the pump passes through the fitting in the No.4 spool valve into the valve. The traction lever, when located in the No.1 position, moves the spool so oil is directed to flow into the No.5 metering valve section. When the traction pedal is pushed forward oil flows out the lines at the rear of the metering valve section to each motor to drive the motors. Low pressure oil returns through the valve and the main return line, through the filter to the reservoir.

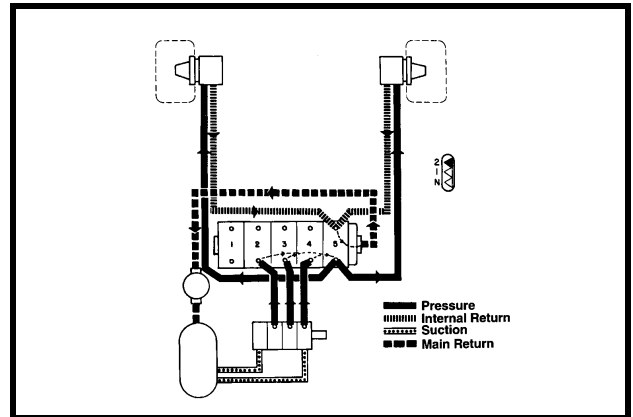

Figure 23

The more sophisticated a hydraulic system becomes, the greater the importance of separating the system into individual circuits when diagnosing a hydraulic problem.

Introduction To Hydraulic Schematics

Accurate diagrams of hydraulic circuits are essential to the technician who must repair it. The diagram shows how the components will interact. It shows the technician how it works, what each component should be doing and where the oil should be going, so that he can diagnose and repair the system.

CIRCUIT DIAGRAMS

There are two types of circuit diagrams.

A: **Cutaway Circuit Diagrams** show the internal construction of the components as well as the oil flow paths. By using colors, shades or various patterns in the lines and passages, they are able to show many different conditions of pressure and flow (Fig 1).

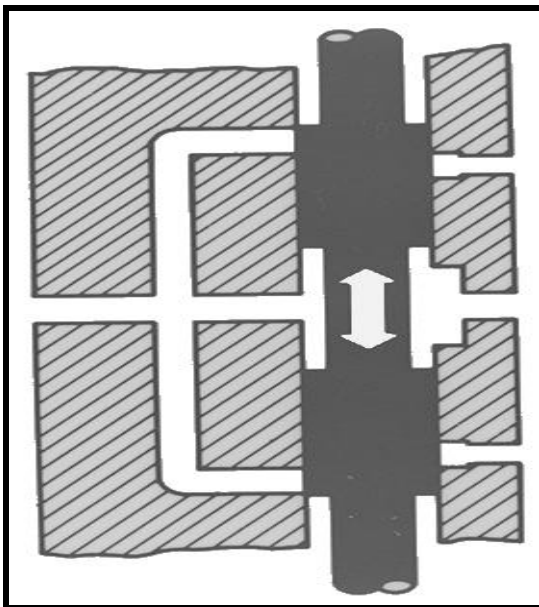

Figure 1

B: **Schematic Circuit Diagrams** are usually preferred for troubleshooting because of their ability to show current and potential system functions. A schematic diagram is made up of consistent geometric symbols for the components and their controls and connections (Fig 2).

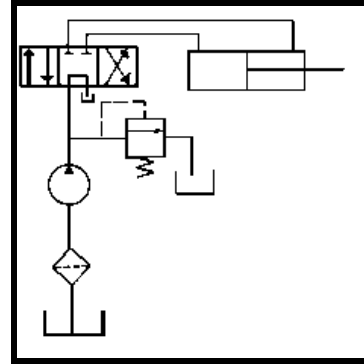

Figure 2

1. Schematic symbol systems

- A: I.S.O = International Standards Organization.
- B: A.N.S.I. = American National Standards Institute
- C: A.S.A = American Standards Association
- D: J.I.C. = Joint Industry Conference

A combination of these symbols are shown in this manual. There are difference between the systems but there is enough similarity so that if you understand the symbols in this manual you will be able to interpret other symbols as well.

2. Hydraulic reservoirs

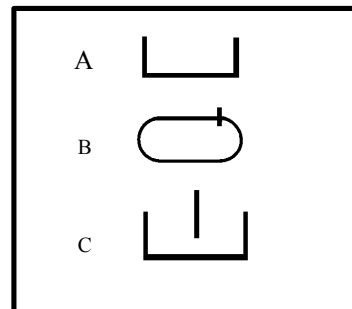

Figure 3

Reservoirs (Fig 3) are pictured as either an open square meaning it is a vented reservoir, or a closed reservoir meaning that it is a pressurized reservoir. Every system reservoir has at least two lines connected to it, and some have many more. Often the components that are connected to it are spread all over the schematic. Rather than having a lot of confusing lines all over the schematic, it is customary to draw individual reservoir symbols close to the component. Similar to the ground symbol in some wiring schematics. The reservoir is usually the only component to be pictured more than once.

3. Lines

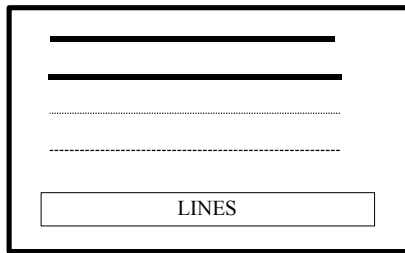

Figure 4

A hydraulic line, tube, hose or any conductor that carries the liquid between components is shown as a line. Some lines have arrows to show direction of oil flow, and lines may be shown as dashed lines to show certain types of oil flow.

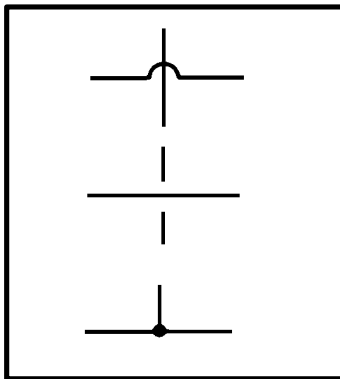

Figure 5

There are lines that cross other lines (Fig 5) but are not connected, there are several ways to show lines that are not connected. Lines that are connected are shown with a dot or sometime just as two lines crossing. If the schematic shows a specific symbol to show lines that are not connected then anything else is connected.

4. Hydraulic pumps

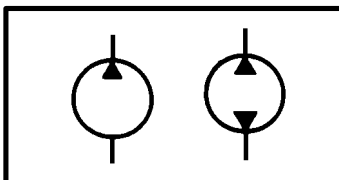

Figure 6

There are many basic pump designs. (Fig 6) A simple fixed displacement pump is shown as a circle with a triangle that is pointing outward. The triangle points in the direction that the oil will flow. If the pump is reversible or is designed to pump in either direction, it will have two triangles in it and they will point opposite of each other indicating that oil may flow in both directions.

5. Hydraulic motors

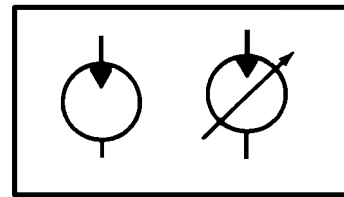

Figure 7

Hydraulic motor symbols (Fig 7) are circles with triangles, but opposite of a hydraulic pump, the triangle points inward to show the oil flows in to the motor. One triangle is used for a non-reversible motor and two triangles are used for a reversible motor. An arrow through a motor shows that it is a variable speed motor.

6. Check valves

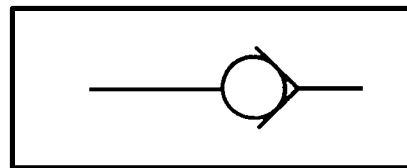

Figure 8

A check valve (Fig 8) is shown as a ball in a V seat. When oil pressure is applied to the left side of the ball, the ball is forced into the V and no oil can flow. When oil pressure is applied to the right side of the ball, the ball moves away from the seat and oil can flow past it. A by-pass check is a one way valve with a spring on the ball end of the symbol. This shows that pressurized oil must overcome the spring pressure before the ball will unseat.

7. Relief valves

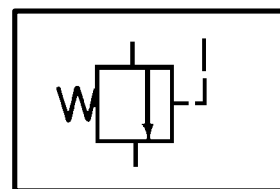

Figure 9

A relief valve (Fig 9) is shown as a normally closed valve with one port connected to the pressure line and the other line connected to the reservoir. The flow direction arrow points away from the pressure line and toward the reservoir. When pressure in the system overcomes the valve spring, pressure is directed through the valve to the reservoir.

8. Hydraulic valves

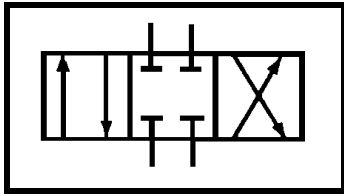

Figure 10

A control valve (Fig 10) has envelopes (squares) that represent the valve spool positions. There is a separate envelope for each valve position and within these envelopes there are arrows showing the flow paths then the valve is shifted to that position. All the port connections are drawn to the envelope that shows the neutral position of the valve. We can mentally visualize the function of the valve in any position. A valve that has parallel lines drawn outside of the valve envelopes shows that this valve is capable of infinite positioning. This valve usually operated between the positions shown. An example of this type of valve would be a flow priority valve or a pressure regulating valve.

9. Actuators

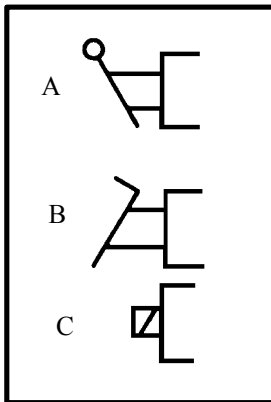

Figure 11

The valve spools can be controlled a variety of ways. The top picture (A) shows the symbol for a lever control. The middle picture (B) shows the symbol for a pedal control (foot operated). The lower control (C) is an electric solenoid.

10. Hydraulic Cylinders

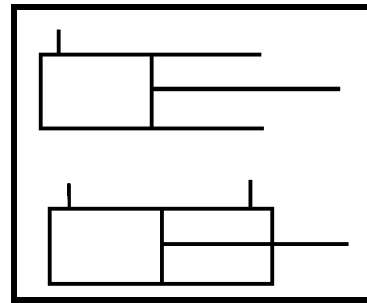

Figure 12

A cylinder symbol (Fig 12) is a simple rectangle representing the barrel. The rod and piston are represented by a tee that is inserted into the rectangle. The symbol can be drawn in any position.

11. Miscellaneous

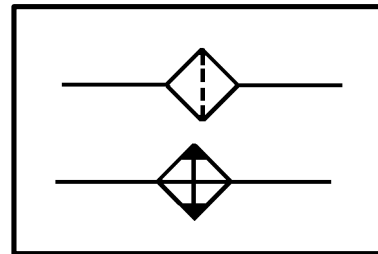

Figure 13

Filters, strainers and heat exchangers (coolers) are shown as squares that are turned 45 degrees and have port connections at the corners. A dotted line 90 degrees to the oil flow indicates a filter or a strainer. A solid line 90 degrees to the oil flow with 2 triangles pointing out indicates a cooler. The symbol for a heater is like that of a cooler, except the triangles point inward.

12. Flow controls

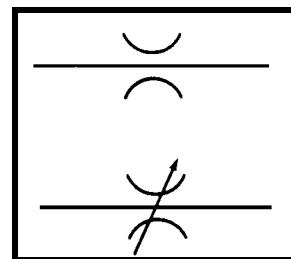









Figure 14



The basic flow control (Fig 14) is a representation of a restrictor. If the restrictor is adjustable a slanted arrow will be drawn across the symbol.

COMMON SYMBOLS







Lines and Line Functions

	Solid Line Main Line
	Dashed Line Pilot or Signal Line
	Enclosure Outline
	Lines Crossing
	Lines Joining
	Liquid Supply
	Gaseous Supply
	Flexible Line

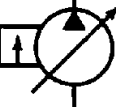

Mechanical Devices

	Mechanical Connections Two Parallel Lines (Shafts, Levers, etc)
	Variable Component (Run Arrow through Symbol at 45 degrees)
	Spring

Pumps and Motors

	Hydraulic Pump Fixed Displacement
	Variable Displacement
	Pressure Compensated Variable Displacement Pump
	Fixed Displacement Hydraulic Pump (Two Directional Flow)
	Hydraulic Motor Fixed Displacement
	Hydraulic Motor Variable Displacement
	Hydraulic Oscillator

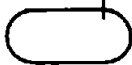
Reservoirs

	Reservoir Open to Atmosphere
	Pressurized
	Line to Reservoir Below Fluid Level
	Line to Reservoir Above Fluid Level

COMMON SYMBOLS

Cylinders

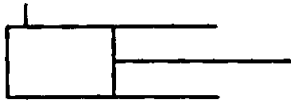

Single Acting

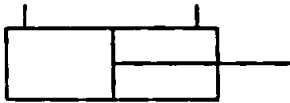

Double Acting
Single Rod End



Double Rod End

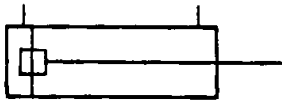

Single Rod End
Fixed Cushion Both Ends

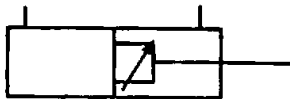

Single Rod End
Adjustable Cushion
Rod End Only

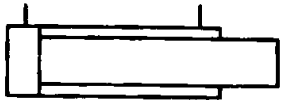

Differential
Cylinder

Valves

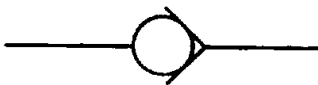

Check



Pilot Operated Check



ON-OFF
Manual Shut Off



Regulating or
Selector Valves

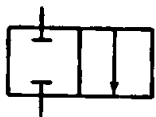

2 Position - 2 Way

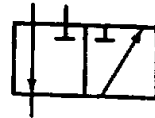

2 Position - 3 Way

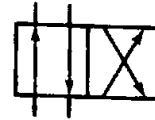

2 Position - 4 Way

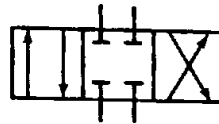

3 Position - 4 Way

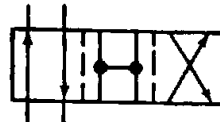

2 Position - 4 Way
Open Center Cross Over

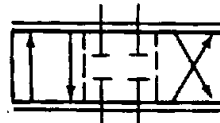

Valve Capable of Infinite
Positioning (Indicated by
Horizontal Lines Drawn
Parallel to the Envelope)

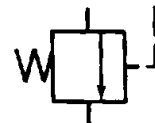

Pressure Relief

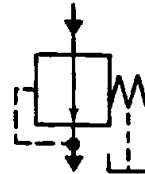

Pressure Reducing

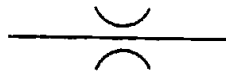

Non-Adjustable Restrictor



Adjustable Restrictor

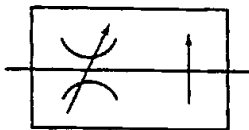

Adjustable Restrictor
Pressure Compensated

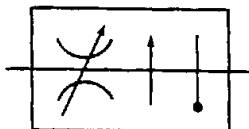

Adjustable Restrictor
(Temperature and
Pressure Compensated)

COMMON SYMBOLS

Valve Actuators



Solenoid



Detent



Spring

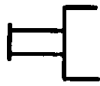

Manual

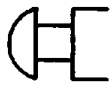

Push Button

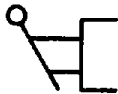

Push-Pull Lever



Pedal



Mechanical



Pressure Compensated



Pilot Pressure
Remote Supply



Liquid Supply

Accessories



Filter



Cooler



Heater



Temperature
Controller



Accumulator
Hydro-Pneumatic



Reversing Motor



Station or
Test Point



Pressure Indicator



Temperature Indicator



Pressure Switch

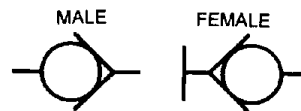

Quick Disconnects
(Disconnected)

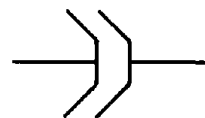

Connection
(Shows Option or
Attachment)

Hydrostatic Transmissions

Hydrostatic transmissions have become quite popular in Turf equipment applications. Their increased use has been due to their simplicity, low maintenance requirements, compact design, operator convenience, and resistance to operator abuse. Hydrostatic transmissions can be easily repaired and maintained if you have a basic understanding of the components and their function.

To begin to understand hydrostatic drive units, let's start by looking at the various types and configurations of hydrostatic transmissions.

The first type is a hydrostatic system which consists of a hydrostatic pump with a remotely mounted motor. (Fig 1) In this type of hydrostatic system the hydrostatic pump is mounted by, and driven by, the units engine. The pump is connected to the drive motor by hoses or steel lines. These motors can be mounted directly to the wheels or to a drive axle.

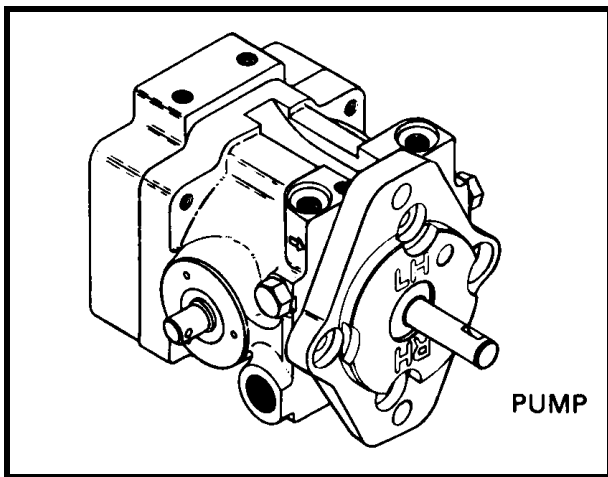

Figure 1

A different type of hydrostatic drive system is an inline pump and motor system. (Fig 2) In this system the motor and pump are constructed as a single unit, this eliminates the necessity of high pressure drive lines between the pump and the motor. This unit is normally mounted to a drive axle or transaxle.

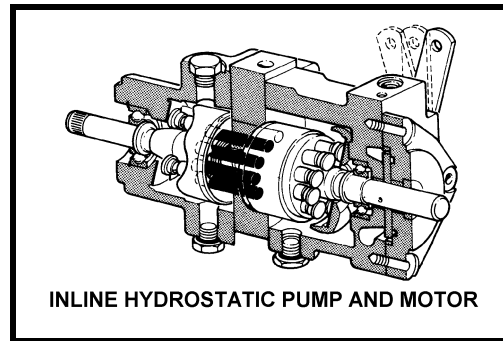

Figure 2

A similar version is the U-type transmission (Fig 3). In this type of system the pump and motor are constructed as a common component with the pump usually located above the motor.

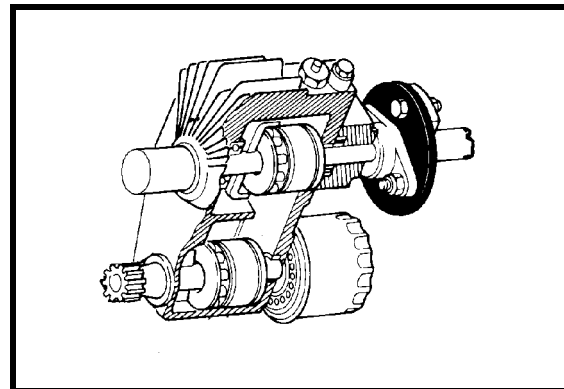

Figure 3

All three systems work well in their designed applications. The remote motor design works well when there is no transmission or transaxle, or when the location of the engine and the drive system call for such a configuration. The U type hydrostatic system is more compact while the inline hydrostatic system is usually easier to repair and maintain.

We will be using the inline hydrostatic pump and motor system in this session for illustration purposes.

A hydrostatic drive consists of a hydrostatic pump, which pumps oil to a drive motor. The most significant feature of a hydrostatic system is the pump. The pump is a variable displacement pump. This means that the output of the pump can be varied and is not controlled only by the engine RPMs like a fixed displacement pump. This requires that the pump needs to be a piston pump.

The pump consists of the following components.

The piston group assembly. (Fig 4)

This rotating piston group is mounted to the input shaft and is driven by the engine. It consists of a piston block with numerous precision machined bores which house the pump pistons. The small pump pistons consist of the piston and the piston slipper. The slipper is usually a brass or aluminum component which is connected to the piston and moves the pistons when the pump is operating.

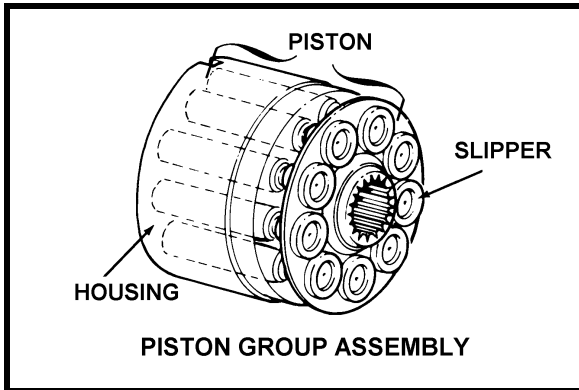

Figure 4

The swash plate. (Fig 5)

The piston slippers pivot and slide against a hardened washer called a thrust washer. The thrust washer is located in the swash plate. The swash plate pivots on two support pins and controls the pump output. As the operator moved the traction control pedal to increase travel speed the swash plate angle increases.

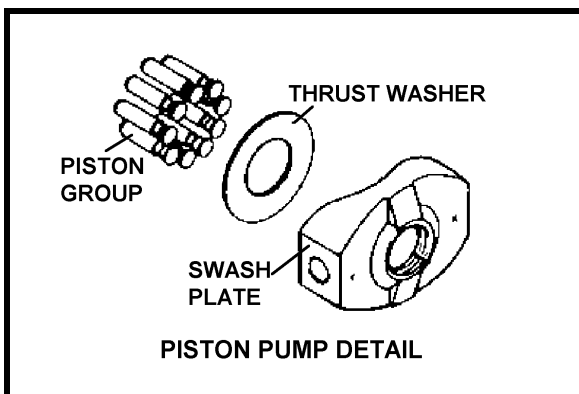

Figure 5

As the piston group spins the pistons are moved in and out of their bores and they pump oil. The quantity of the oil being pumped is controlled by the angle of the swash plate. As long as the swash plate is kept in the neutral position, no oil will be

pumped. As the operator moves the traction control pedal the angle of the swash plate increases, this in turn increases the piston travel. As the piston travel increases the amount of oil pumped increases and the travel speed changes.

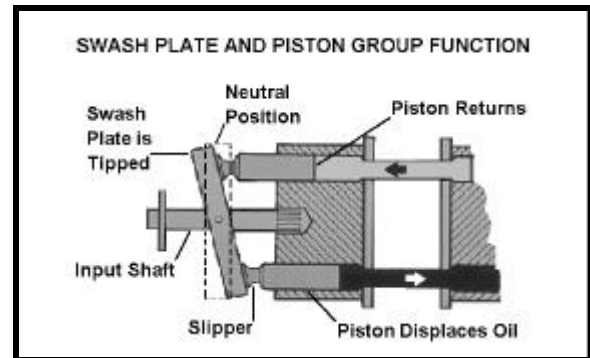

Figure 6

The charge pump. (Fig 7)

While the transmission is in operation there is a constant loss of oil (by design) within the components of the pump and motor. For example, holes in the end of each piston allow a small amount of oil to form a cushion between the slipper's face and the thrust washer. This oil must be continuously replenished. Built in to the system is pump called a charge pump. This pump can be a gear pump, or a gerotor pump. Both of these pumps are fixed displacement. Fixed displacement means that the pump's output is fixed by the RPM of the engine. It cannot be varied except by increasing or decreasing the speed of the engine. Excessive oil not required by the drive circuit opens the charge relief valve and flows back to the reservoir.

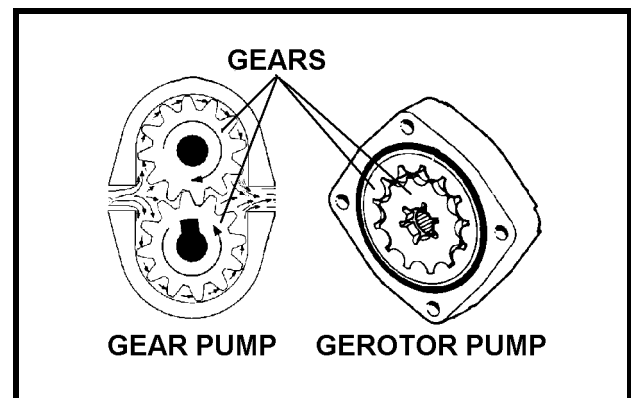

Figure 7

Directional charge checks. (Fig 8)

Directional charge check valves are incorporated into the charge circuit to direct the charge pump output to the low pressure side of the drive circuit. The oil will flow into the low pressure side to replace the oil lost through normal leakage. The oil in the high pressure side closes the remaining charge check valve so that no high pressure oil can bleed off into the charge circuit.

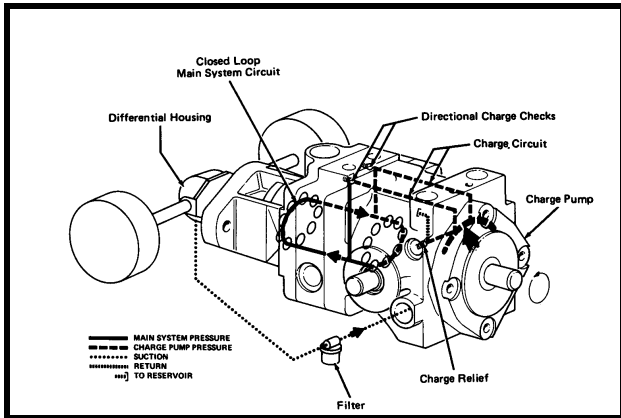

Figure 8

Hydrostatic motor. (Fig 9)

On a remote hydrostatic motor type system the hydrostatic motors can be a simple gear type motor or a piston type motor. When the motor is built as part of the complete assembly like an inline or U type system the motor is a piston type motor very similar the piston pump except that the swash plate is usually a fixed swash plate. Being fixed the stroke of the pistons remain constant. The motor's speed of rotation can not be changed except by changing the volume of oil that it receives from the pump. Remember that a given column of oil will cause the motor to turn at a given speed. More oil will increase the motor speed. Less oil will slow it down.

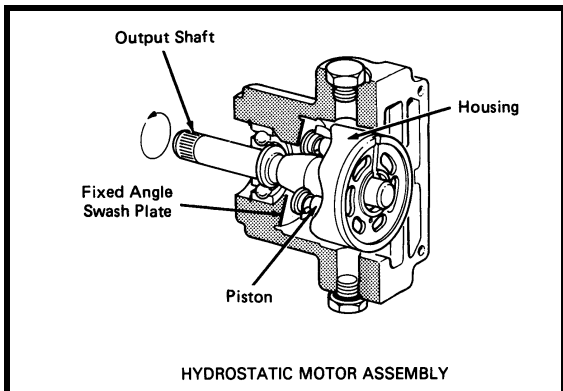

Figure 9

OVERALL OPERATION

As the engine turns the pump rotating group, the pistons run on the swash plate which is in the neutral position. (Fig 10) With the swash plate in neutral there is no movement of the pistons so no oil is being pumped.

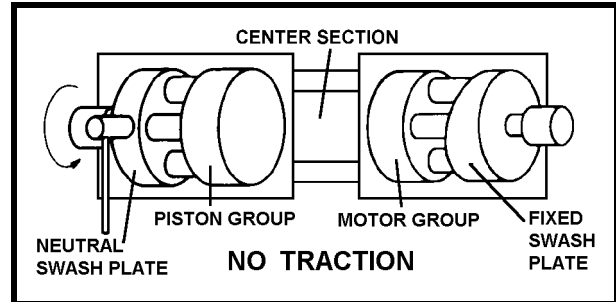

Figure 10

As the operator moves the traction control pedal the swash plate angle increases and the pump pistons begin to displace oil. This oil is directed to the pump section and the unit moves. (Fig 11)

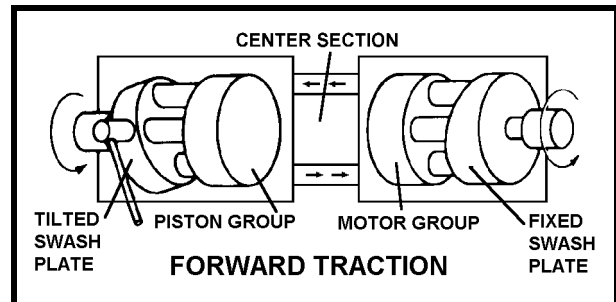

Figure 11

When the operator needs to change directions the traction pedal is moved back to the neutral position and then moved to the reverse position. In the reverse position the swash plate moves in the opposite direction as it did in the forward direction. In this position the oil is pumped to the opposite side of the motor and the unit moves in reverse. (Fig 12)

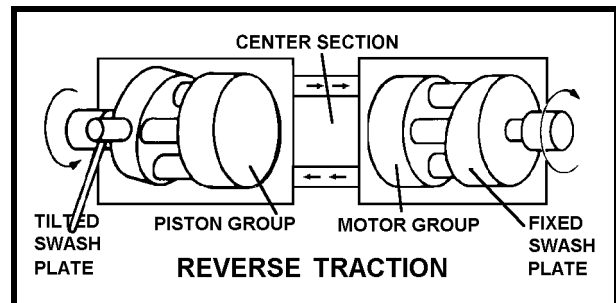

Figure 12

IMPLEMENT CIRCUIT (Fig 13)

Some machines require hydraulic oil to operate the implement lift functions. This can be accomplished by using a larger charge pump. This pump has a larger displacement of oil than is needed to replenish the oil lost in the drive circuit. The excess oil not required to replenish the drive circuit, opens and passes through the charge relief and is directed to the implement lift valve. At the implement valve the oil can be directed to a lift cylinder.

NOTE: It is important to realize that the main circuit must have enough oil flow and pressure supplied to it to replenish the oil lost in the drive circuit. Should the main circuit develop excessive leakage, the charge relief valve will not be opened and no oil will flow to the implement circuit.

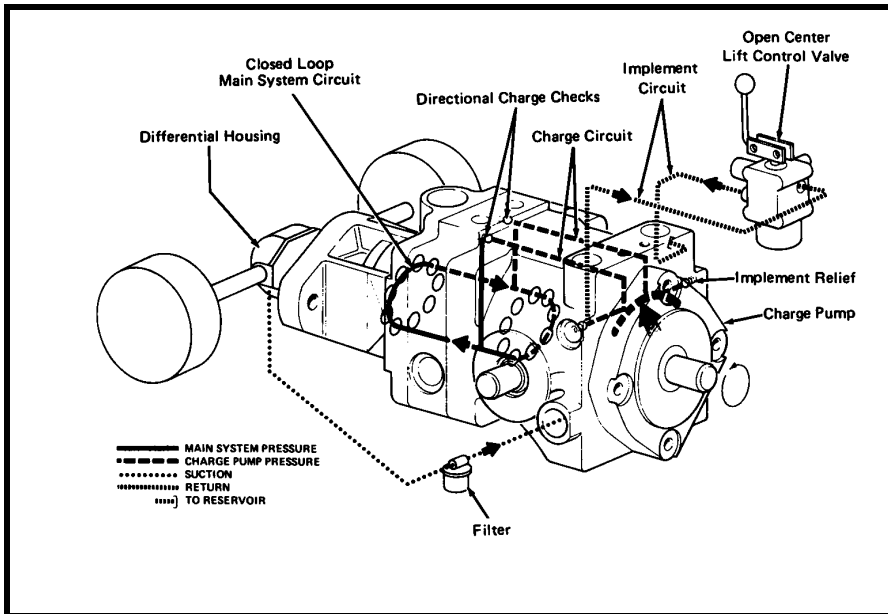

Figure 13

If the lift control lever remains actuated after the lift cylinder is extended, (Fig 14) the flow from the charge pump is forced through the implement relief valve and will return to the reservoir.

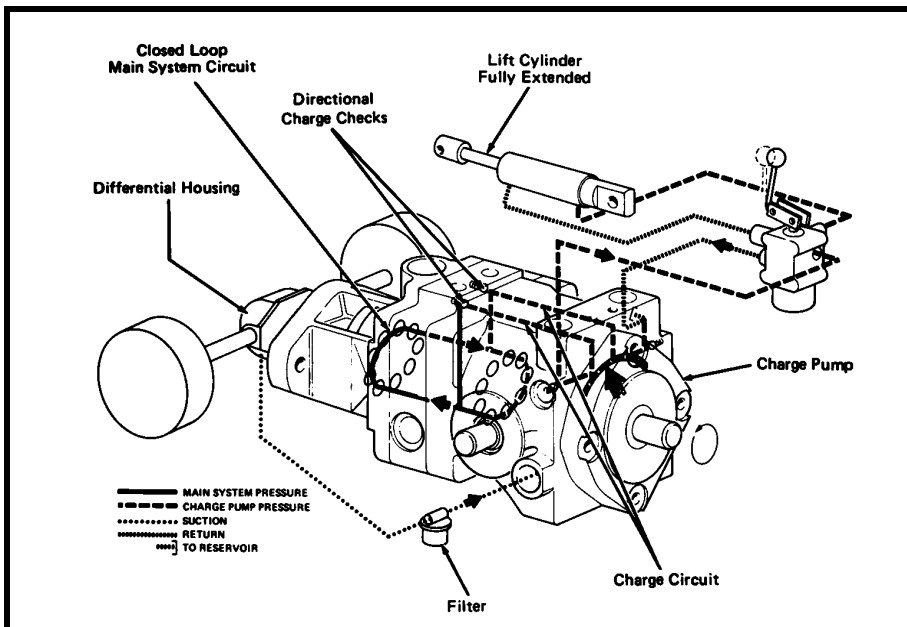

Figure 14

Hydraulic Hoses and Fittings

Hydraulic Hoses

Hydraulic hoses are subject to extreme conditions such as, pressure differentials during operation and exposure to weather, sun, chemicals, high temperature operating conditions or mishandling during operation or storage. Hoses that move during operation are more susceptible to these conditions than others.

Inspect hoses frequently for signs of deterioration or damage. Check hoses for leakage and replace when leaks are found.



Figure 1

When replacing a hydraulic hose, be sure that the hose is straight (not twisted) before tightening the fittings. This can be done by observing the imprint on the hose. Using two wrenches, hold the hose straight with one wrench and use the other wrench to tighten the hose swivel nut to the fitting. Use procedures shown in the Toro Hydraulic Hose Servicing Manual, Form No. 94-813-SL.



WARNING

Before disconnecting or performing any work on a hydraulic system, all pressure in the system must be relieved by stopping the engine and lowering or supporting the implement.



Keep body and hands away from pin hole leaks or nozzles that eject hydraulic fluid under pressure. Use paper or cardboard, not hands, to search for leaks. Hydraulic fluid escaping under pressure can have sufficient force to penetrate the skin and do serious damage. If fluid is injected into the skin, it must be surgically removed within a few hours by a doctor familiar with this type of injury or gangrene may result.



Figure 2

O-ring Face Seal (ORFS) Fittings

1. Make sure both threads and sealing surfaces are free of burrs, nicks, scratches, or any foreign material.
2. Make sure the O-ring is installed and properly seated in the groove. It is recommended that the O-ring be replaced any time the connection is opened.
3. Lubricate the O-ring with a light coating of oil.
4. Put the tube and fitting squarely into position on the face seal end of the fitting and tighten the nut until finger tight.
5. Mark the nut and fitting body. Hold the body with a wrench. Use another wrench to tighten the nut to the correct flats from finger tight (F.F.F.T). The markings on the fittings will verify that the connection has been tightened.

Size	F.F.F.T
4 (1/4 in. Nominal hose or tubing)	.75 ± .25
6 (3/8 in.)	.75 ± .25
8 (1/2 in.)	.75 ± .25
10 (5/8 in.)	1.00 ± .25
16 (1 in.)	.75 ± .25

JIC 37° Flare Fittings

1. Make sure both threads and sealing surfaces are free of burrs, nicks, scratches, or any foreign material. Check for a cracked or distorted flare (sealing point).
2. Tighten the nut finger tight until it bottoms out against the seat. Mark a line on the nut and the fitting body.
3. Hold the body with a wrench. Use another wrench to tighten the nut to the correct flats from finger tight (F.F.F.T). The markings on the nut and fitting body will verify that the connection has been tightened. After tightening, extend the line from the nut to the body (optional for ease of remake).

Size	Initial F.F.F.T.	Remake F.F.F.T
4 (1/4 in. Nominal)	2 - 2½	¾ - 1
6 (3/8 in.)	2 - 2¼	1
8 (1/2 in.)	1½ - 1¾	1
10 (5/8 in.)	1½ - 1¾	¾
12 (3/4 in)	1½	¾
14 (5/8 in)	2	1¼
16 (1 in.)	1¼ - 1½	¾ - 1

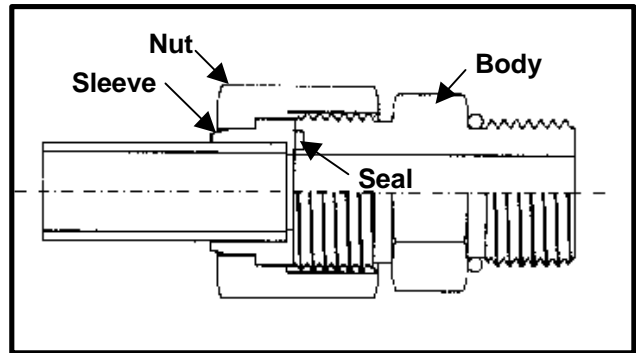

Figure 3

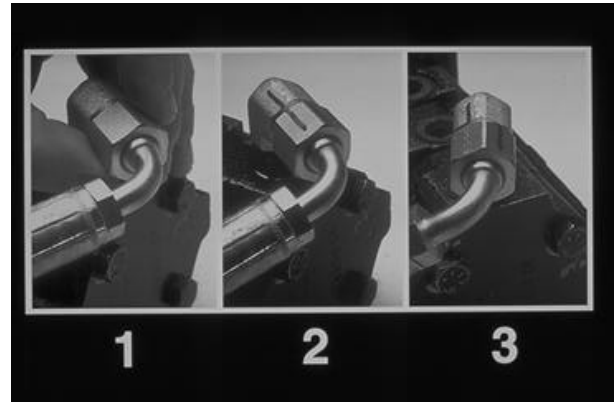

Figure 4

Line tightening procedure:

1. Tighten connection finger tight.
2. Mark connector.
3. Tighten correct number of flats from spec. Chart.



Figure 5

SAE Straight thread O-ring Port Fittings (Non-Adjustable)

1. Make sure both threads and sealing surfaces are free of burrs, nicks, scratches, or any foreign material.
2. Always replace the O-ring seal when this type of fitting shows signs of leakage.
3. Lubricate the O-ring with a light coating of oil.
4. Install the fitting into the port and tighten it down until finger tight.
5. Tighten the fitting to the correct flats from finger tight (F.F.F.T.).

Size	F.F.F.T.
4 (1/4 in. nominal hose or tubing)	1.00 ± .25
6 (3/8 in.)	1.50 ± .25
8 (1/2 in.)	1.50 ± .25
10 (5/8 in.)	1.50 ± .25
12 (3/4 in.)	1.50 ± .25
16 (1 in.)	1.50 ± .25

SAE Straight thread O-ring Port Fittings (Adjustable)

1. Make sure both threads and sealing surfaces are free of burrs, nicks, scratches, or nay foreign material.
2. Always replace the O-ring seal when this type of fitting shows signs of leakage.
3. Lubricate the O-ring with a light coating of oil.
4. Turn back the jam nut as far as possible. Make sure the back up washer is not loose and is pushed up as far as possible (step 1).
5. Install the fitting into the port and tighten finger tight until the washer contacts the face of the port (step 2).
6. To put the fitting in the desired position, unscrew it by the required amount, but no more than one full turn (step 3).
7. Hold the fitting in the desired position with a wrench and turn the jam nut with another wrench to the correct flats from finger tight (F.F.F.T.) (step 4)

Size	F.F.F.T.
4 (1/4 in. nominal hose or tubing)	1.00 ± .25
6 (3/8 in.)	1.50 ± .25
8 (1/2 in.)	1.50 ± .25
10 (5/8 in.)	1.50 ± .25
12 (3/4 in.)	1.50 ± .25
16 (1 in.)	1.50 ± .25

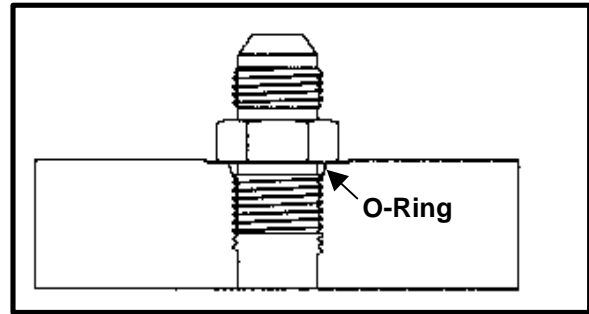

Figure 6

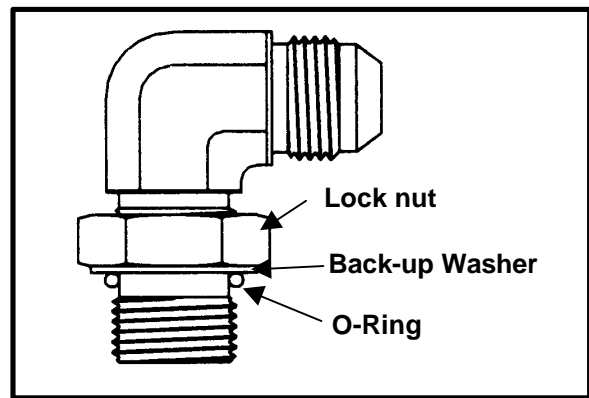

Figure 7

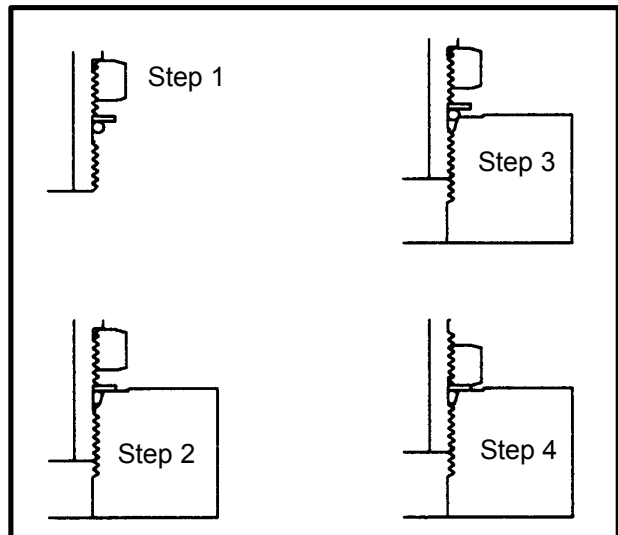

Figure 8

O-ring Kit

O-ring face seal connections on Toro equipment require the use of special 90 Durometer O-rings. Toro recommends that the O-rings need to be replaced whenever a connection is loosened. An O-ring kit is available containing quantities of O-rings for both face seal and port seal connections used in Toro equipment.

O-ring Kit: P/N 16-3799



Figure 9

Removing Hydraulic System Components

1. Thoroughly clean the machine before disconnecting, removing or disassembling any hydraulic components. Always keep in mind the need for cleanliness when working on hydraulic equipment.
2. Put caps or plugs on any hydraulic lines or fitting left open or exposed.
3. Put labels on disconnected hydraulic lines and hoses for proper installation after repairs are completed.

After Repair or Replacement of Components

1. Check oil level in hydraulic reservoir and add correct oil if necessary.

IMPORTANT: Drain and refill hydraulic system reservoir and change oil filter if component failure was severe or system is contaminated. If there is a severe failure in a closed loop system, flush all lines and components in the system.

2. After repairs, check the control linkage for proper adjustment, binding or broken parts.
3. After disconnecting or replacing components, operate the machine functions slowly until the air is out of the system.
4. Check for hydraulic leaks. Shut off the engine and correct leaks if necessary. Check oil level in the reservoir and add the correct oil if necessary.

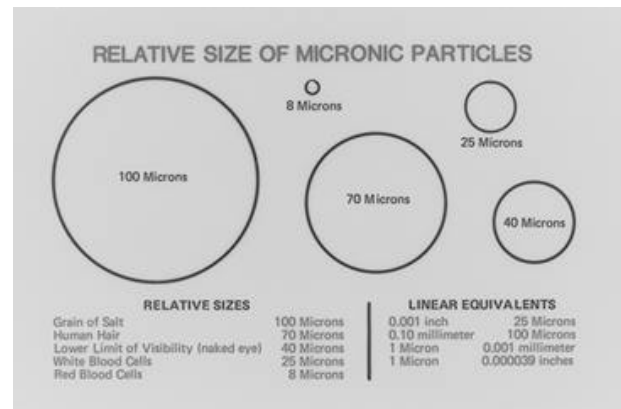

The most important rule of hydraulic system maintenance is...

**KEEP EVERYTHING
CLEAN !**

Principles of Hydraulic Test Equipment

A hydraulic system with an excessive increase in heat or noise is a potential failure. Should either of these conditions be noticed, immediately stop the machine, turn off the engine, locate the cause of the trouble, and correct it before allowing the machine to be used again. Continued use of an improperly functioning hydraulic system could lead to extensive internal damage.

When troubleshooting a hydraulic problem:

1. Know the hydraulic system for the machine:
 - Study the schematics, Operators Manual and Service Manual.
 - Know how the system works and what the relief valve setting and the pump output should be.
2. Talk to the operator:
 - How did the machine act just as it started to malfunction?
 - Was any “do-it-yourself” service performed or did anyone else attempt to repair the machine?
 - How was the machine used and when was maintenance last performed?
3. Operate the machine:
 - Operate the machine in conditions simulating when the malfunction occurred. Verify what the operator described.
 - Are the gauges and warning lights operating correctly.
 - Do the controls feel spongy or stick.
 - Check for any unusual sounds, smells, or smoke. At what speed or operating cycles does this occur.
4. Inspect the machine:
 - Check the hydraulic fluid level and condition. Is the fluid dirty or filters plugged?
 - Check for overheating. Does the oil have a burnt odor? Is the oil cooler plugged or lines caked with dirt?
 - Look for bent or collapsed fluid lines. Check for leaks, loose fasteners, cracked welds, binding pivot points, damaged linkage, etc.
5. List possible causes:
 - Note what was reported by the operator and verified by you.
 - List what you found during your inspection.
 - Remember that there may be more than one cause leading to the failure or malfunction.

6. Determine which cause is most likely the problem:
 - Look at your list of most possible causes and determine which are the most likely. Use the troubleshooting charts in the Service Manual.
7. Test your findings
 - Operate the machine with a hydraulic tester connected to the suspected malfunctioning circuit.
 - It may be necessary to replace or adjust a component to verify your findings.

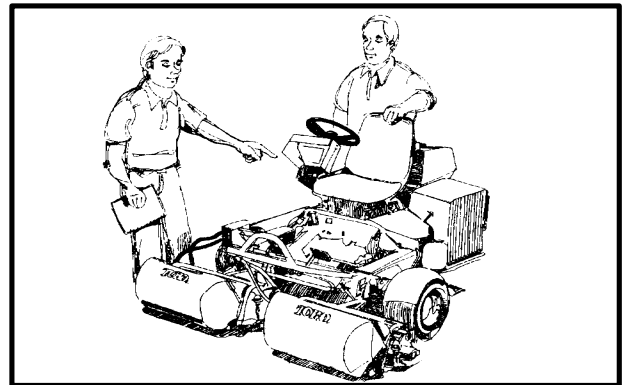

Figure 1

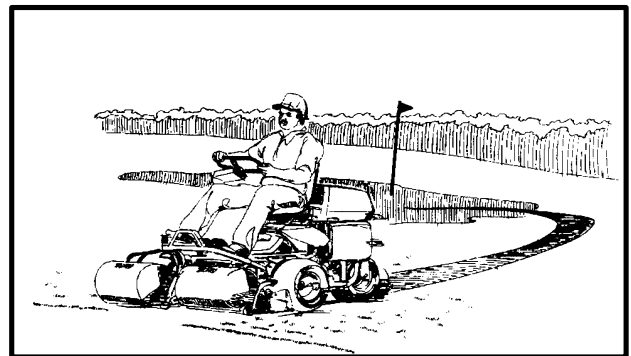

Figure 2

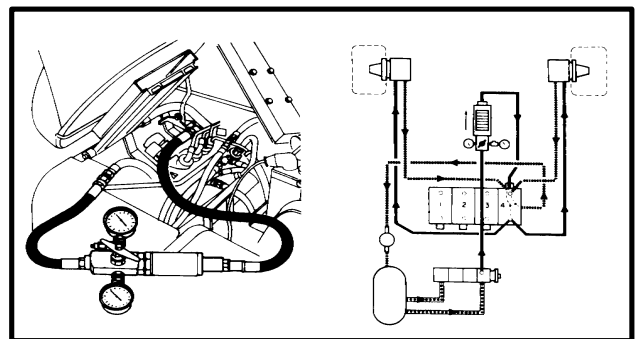

Figure 3

Hydraulic test equipment allows you to observe the amount of oil pressure and oil flow in a circuit under various conditions.

Hydraulic testers may vary significantly in size, construction, accuracy, and cost. The decision as to which tester to purchase should be influenced by what type of tests will be performed on all the hydraulically powered equipment in the shop.

High And Low Pressure Test Gauges

Low pressure gauge 1000 PSI, high pressure gauge 5000 PSI, and associated hoses and fittings.



Figure 4

Hydraulic Pressure Gauges (Quick Disconnect type)

For use on Toro machines that have test ports with quick disconnect adapters. 1000, 5000, and 10,000 PSI gauges with extension hose and quick disconnect fittings.

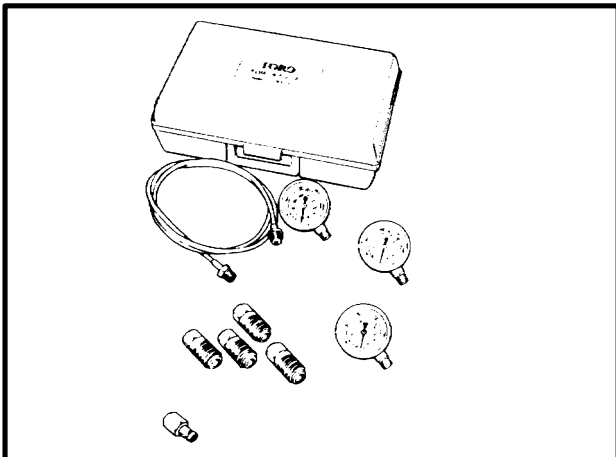

Figure 5

Hydraulic Tester (With Pressure and Flow Capabilities)

1. INLET HOSE: Hose connected from the system circuit to the inlet side of the tester.

2. LOAD VALVE: If required, upon turning the valve to restrict flow, a simulated working load is created in the circuit.

3. LOW PRESSURE GAUGE: Low range gauge to provide accurate readings at low pressure, 0-1000 PSI.

This gauge has a protector valve which cuts out when pressure is about to exceed the normal range for the gauge. The cutout pressure is adjustable.

4. HIGH PRESSURE GAUGE: High range gauge to accommodate pressure beyond the capacity of the low pressure gauge, 0 - 5000 PSI.

5. FLOW METER: This meter measures actual oil flow in the operating circuit. The reading is given in gallons per minute (GPM) with a gauge rated at 15 GPM.

6. OUTLET HOSE: Hose from the outlet side of the hydraulic tester to be connected the hydraulic circuit.



Figure 6

Before Performing Hydraulic Tests

ALL OBVIOUS AREAS SUCH AS OIL SUPPLY, FILTERS, IMPROPER ADJUSTMENT BINDING LINKAGE, OR LOOSE FASTENERS MUST BE CHECKED BEFORE ASSUMING THAT A HYDRAULIC COMPONENT IS THE SOURCE OF THE PROBLEM BEING EXPERIENCED.

1. Thoroughly clean the machine before disconnecting or disassembling any hydraulic components. Always keep in mind the need for cleanliness when working on hydraulic equipment.
2. Put caps or plugs on any hydraulic lines left open or exposed during testing or removal of components.
3. The engine must be in good operating condition. Always use a tachometer when doing a hydraulic test. ENGINE SPEED WILL AFFECT THE ACCURACY OF THE TESTER READINGS.
4. To prevent damage to the tester or components, the inlet and outlet hoses must be properly connected and not reversed (tester with pressure and flow capabilities).
5. To minimize the possibility of damaging the components, completely open the load valve by

turning it counter clockwise (tester with pressure and flow capabilities).

IMPORTANT: Pumps used on Toro equipment are of a positive displacement type. If a tester is installed in a portion of the circuit not protected by a relief valve and the pumps output flow is completely restricted or stopped, damage to the pump or other components could occur.

6. Install fittings finger tight, far enough to insure that they are not cross-threaded, before tightening them with a wrench.
7. Position the tester hoses so that rotating machine parts will not make contact with them and result in hose damage.
8. Check the oil level in the reservoir.
9. Check the control linkage for improper adjustment, binding or broken parts.
10. All hydraulic test should be made with the hydraulic system at normal operating temperature.
11. Use gauges of proper pressure ratings when performing hydraulic tests.
12. Always keep safety in mind while performing tests. Keep bystanders away from the equipment.

HOOK UP NO. 1

TEST A: PUMP FLOW

Connect the tester in series with the pump output circuit, (Fig 7) and shift the spool valve to the neutral (off) position, we can then measure the pump output to insure that the oil flow is adequate to drive the motor at the desired speed. **Use extreme caution when using this procedure. There is no relief valve between the pump and the restrictor valve when tested in this manner. Be absolutely sure the flow meter is open when starting the engine.**

TEST B: MECHANICAL BINDING

Using the same hookup as in test A, if we shift the spool valve to the run position, we can observe the pressure gauge reading and verify the pressure required to rotate the hydraulic motor.

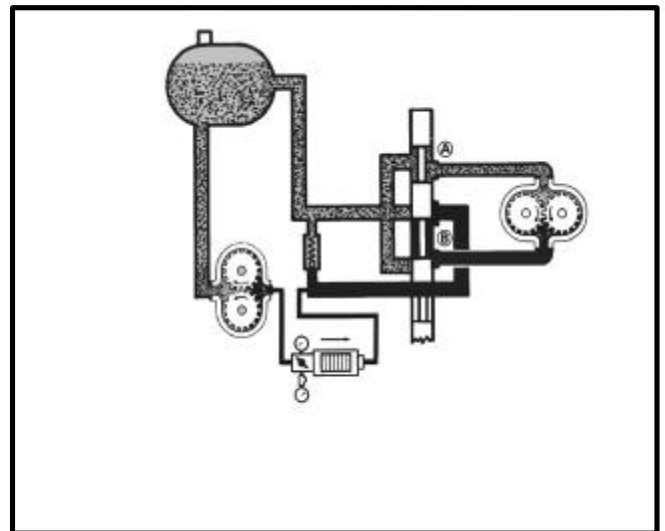

Figure 7

REVIEW QUESTIONS

Answer the following review questions.

1: A larger displacement pump operating at the same speed will:

- A: Move more oil
- B: Move less oil.
- C: Displacement has no effect on oil flow.

2: When a open center spool valve is in the neutral position:

- A. All oil flow stops.
- B. Oil flows back to reservoir.
- C: Oil flows to lower port.
- D: Oil flows to raise port.

3: The o-rings on a solenoid valve are matched to the valve and should never be replaced.

- A: True
- B: False

4: The hydraulic oil pump supplies the system with:

- A: Oil flow, (gpm)
- B: Oil pressure (psi)
- C: Non of the above

5: The increase in mechanical advantage in a hydraulic system is affected by:

- A: The rate of oil flow
- B: The diameter of the pistons.
- C: The relief valve setting.
- D: all of the above.

6: The following symbol is:

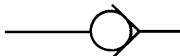

- A : Variable speed motor.
- B: Check Valve.
- C: Orifice.
- D: Accumulator.

7: The following symbol is:



- A: Oil Cooler.
- B: Reversible Hydraulic Motor.
- C: Combination pump\motor.
- D: Reversible Hydraulic Pump.

8: The following symbol is:



- A: Vented Reservoir.
- B: Pressurized Reservoir.
- C: Open Center Valve.
- D: Operators Manual Box.

9: The following symbol is:

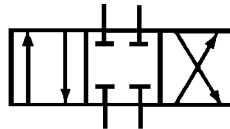

- A: 3 Position Valve.
- B: Closed Center Valve.
- C: All Of The Above.

10: The following symbol is:



- A: Oil Cooler.
- B: Oil Filter.
- C: Flow restrictor.
- D: None Of The Above

REVIEW QUESTIONS

- 11: A Hydrostatic Drive pump is:
- A: Fixed displacement.
 - B: Variable displacement.
 - C: Driven by the wheels.
- 12: The purpose of the charge pressure circuit is:
- A: Pressurize the hydraulic filter.
 - B: Replenish internal oil leakage in drive circuit.
 - C: Pressurize transaxle case to keep dirt out.
 - D: Keep battery charged
 - E: Supply pressurized oil to the rotating group, keeping the slippers against the swash plate.
 - F: Both B & E.
 - G: None of the above.
- 13: A hydraulic motor converts fluid energy into rotational movement.
- A: True.
 - B: False.
- 14: Never use your hands to try and find a hydraulic oil leak.
- A: True.
 - B: False.
- 15: F.F.F.T is
- A: Fractional Fitting Face Turns
 - B: Fitting Face Flat Turns
 - C: Flats From Finger Tight
 - D: None of the above
- 16: A properly installed hose will have a 45° twist in the hose.
- A: True
 - B: False
- 17: Fitting O-rings should always be installed dry.
- A: True
 - B: False
- 18: When checking pump flow:
- A: Completely restrict pump flow.
 - B: Use extreme caution if tester is ahead of relief valve.
 - C: Connect tester in series with the system.
 - D: Both B & C.
- 19: Hydraulic test should be conducted with:
- A: The reservoir full of oil.
 - B: The hydraulic system at normal operating temperature.
 - C: The proper size gauges installed.
 - D: All of the above.
- 20: The units engine has no effect on hydraulic tests.
- A: True
 - B: False



Commercial Products