



## DLW400ESA4

Welder

### WhisperWeld™

DC Rated Output — 400 Amps

AC Max. Output — 14 kW (14 kVA)

AC Rated Output — 12 kW (12 kVA)

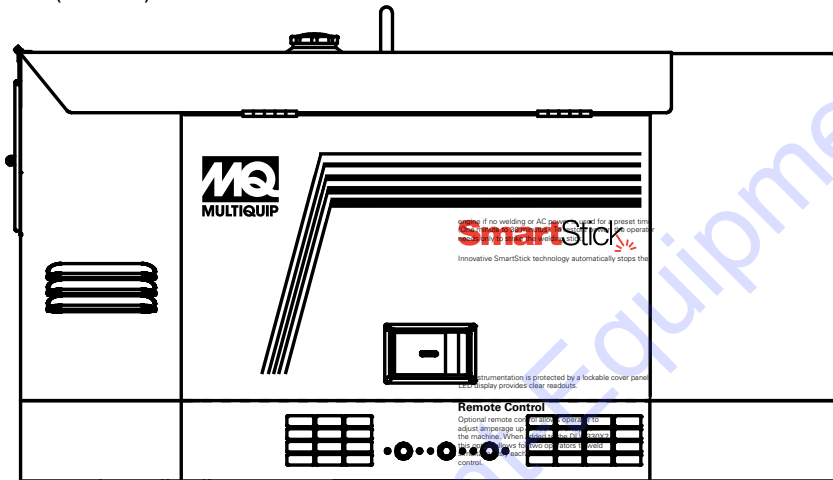

#### STANDARD FEATURES

- Heavy duty, 4-cycle, direct injection, diesel engine provides maximum reliability.
- EPA emissions certified — Tier 4 Final emissions compliant.
- Single-Side Maintenance Design — Quick, direct access to all filters. External fluid drain extensions allow fast, easy service.
- Electronic governor system maintains frequency to  $\pm 0.25\%$
- Sound attenuated, weather resistant, compact steel housing provides operation at 70dB(A) at 23 feet. Fully lockable enclosure allows safe unattended operation.
- E-coat and powder coat paint provides durability and weather protection.
- Internal fuel tank with digital fuel gauge.
- Brushless alternator reduces service and maintenance requirements and meets temperature rise standards for Class F insulation systems.
  - Open delta alternator design provides virtually unlimited excitation for maximum motor starting capability.
  - Automatic voltage regulator (AVR) provides precise regulation.
- Simultaneous AC and DC power.
- Multi-process welding - SMAW, FCAW, GMAW, GTAW and ACAC.
- Smart Stick function automatically shuts the engine down during periods of no load. The operator only needs to tap the welding rod to the grounded work for the engine to restart.
- E-mode improves fuel efficiency by allowing one or two operators to weld up to a total of 200 amps.
- Arc Force control allows the operator to fine tune DC current during low voltage welding conditions which helps in preventing electrodes from sticking during short arc length welding.
- Dual operator output ability.
- Fully-covered power panel — Single phase receptacles allow fast and convenient hookup for most applications.
- Complete generator instrumentation — Includes a 2-pole circuit breaker, AC voltmeter, hour meter, idle control switch, warning lamp display, and ignition switch.
- Automatic safety shutdown system monitors low oil pressure, high water temperature and battery charge via warning lamp display module.
- Full panel GFCI protection - OSHA and NEC compliant.



# DLW400ESA4

## Welder

### SPECIFICATIONS

Generator Specifications	
Design	Revolving field, self-ventilated brushless, drip-proof, single bearing
Armature Connection	Series
Phase	Single Phase (3-wire)
Max. Output	14 kW (14 kVA)
Rated Output	12 kW (12 kVA)
Rated Voltage	120, 240 V
Power Factor	1
Voltage Regulation (No load to full load)	120V $\pm$ 5% / 240V $\pm$ 1.5%
Generator RPM	3600
Frequency	60 Hz
No. of Poles	2
Winding Pitch	2/3
No. of Leads	4
Frequency Regulation: No Load to Full Load	3 - 5% of mean value for constant loads from no load to full load.
Frequency Regulation: Steady State	$\pm$ 0.25% of mean value for constant loads from no load to full load.
Insulation	Class F
Sound Level dB(A) Full load at 23 feet	70

Engine Specifications	
Make / Model	Kubota / D902-E4B
Emissions	EPA Tier 4 Final Certified
Starting System	Electric
Design	Vertical, 4-cycle, liquid cooled, diesel engine
Displacement	54.8 in <sup>3</sup> (898 cc)
No. cylinders	3
Bore x Stroke	2.83 x 2.89 in. (72 x 73.6 mm)
Rated Engine Power Output	23.9 hp (17.8 kW)
Engine Speed	3600 rpm
Oil Capacity	0.95 gallons (3.6 liters)
Coolant Capacity	1.12 gallons (4.25 liters)
Starting System	Electric
Battery	12V 45Ah x 1. (55B24L), Group No.: 22F, CCA: 410

Fuel System		
Recommended Fuel	ASTM-D975-No.1 & No.2-D*	
Fuel Tank Capacity	11.1 gallons (42 liters)	
<b>Fuel Consumption**</b>	<b>gph</b>	<b>lph</b>
At 350A load	1.32	5.0
At 260A load	1.00	3.7
At 175A load	0.78	3.0
At 88A load	0.63	2.3

\* - Use ultra-low sulfur diesel fuel.  
\*\* - DC Welding Current.

Amperage (AC)	
Rated Voltage	Amps
120 Volt	50 x 2 Continuous
240 Volt	50 Continuous

Welding Output (DC)	Constant Voltage (CV)	Constant Current (CC)
Single Operation		
Rated Output (kW)	11.0	11.9
Rated Current (Amps)	350	350
Rated Voltage***	31.5	34.0
Voltage Range	14 ~ 36	N/A
Current Range	N/A	30 ~ 400
Rated Duty Cycle	100%	100%
Dual Operation		
Rated Output (kW)	3.99 x 2	4.73 x 2
Rated Current (Amps)	175 x 2	175 x 2
Rated Voltage***	22.8	27.0
Voltage Range	14 ~ 28	N/A
Current Range	N/A	30 ~ 200
Rated Duty Cycle	100%	100%

\*\*\* - Rated voltage at 100% duty cycle.

e Mode Selector Switch	Single			Dual		
	Low (2300 rpm)	Variable (2300-3600 rpm)	High (3600 rpm)	Low (2300 rpm)	Variable (2300-3600 rpm)	High (3600 rpm)
VARIABLE /LOW	N/L, 30-200A	N/L, 200-400A	—	N/L, A+B Total 30-200A	N/L, A+B Total 200-400A	—
HIGH/LOW	N/L	—	30-400A	N/L	—	A+B Total 30-400A
HIGH	—	—	N/L, 30-400A	—	—	N/L, A+B Total 30-400A

	Single			Dual		
	Low (2300 rpm)	Variable (2300-3600 rpm)	High (3600 rpm)	Low (2300 rpm)	Variable (2300-3600 rpm)	High (3600 rpm)
Current Range	30-200A	30-400A	30-400A	30-200A	30-200A	30-200A
Electrode Size	$\phi$ 3/32" to $\phi$ 3/16"	$\phi$ 3/32" to $\phi$ 5/16"	$\phi$ 3/32" to $\phi$ 5/16"	$\phi$ 3/32" to $\phi$ 3/16"	$\phi$ 3/32" to $\phi$ 3/16"	$\phi$ 3/32" to $\phi$ 3/16"

### WARRANTY\*

#### Kubota Engine

12 months from date of purchase with unlimited hours or 24 months from date of purchase with 2000 hours (whichever comes first).

#### Welder

24 months from date of purchase or 2000 hours (whichever occurs first).

#### Trailer

12 months excluding normal wear items.

\* Refer to the express written, one-year limited warranty sheet for additional information.

### NOTICE

Specifications sheet is subject to change and is not intended for use in installation design.



# DLW400ESA4

## Welder

**MQ POWER DECIBEL LEVELS**

Our soundproof housing allows substantially lower operating noise levels than competitive designs. WhisperWelds are at home on construction sites, in residential neighborhoods, and at hospitals — just about anywhere.

- 90 — Subway / truck traffic
- 80 — Average city traffic
- 70 — **WhisperWeld at 23 feet**  
— Inside car at 60 mph
- 60 — Air conditioner at 20 feet
- 50 — Normal conversation

### OPTIONAL WELDER FEATURES

- **Wire Remote Control** — allows the operator to adjust amperage/voltage up to 100 feet away from the machine.
- **Electrode and Work Clamp Welding Cable** — superior flexibility and durability.
- **Battery Charger** — automatically monitors and maintains the battery even after full charge has been achieved.
- **Oil Pan Heater** — for easy starting in cold weather climates (125 watts).
- **In-Line Fuel Heater** — recommended for de-gelling fuel in cold weather starting conditions (ambient temperatures ranging at or below  $\leq 32^{\circ}\text{F}$ ).
- **Trailer Mounted Package** — Heavy duty highway legal trailer with single axle configuration.

- TRLRMP without fuel tank
- TRLRMPXF with 28 gallon fuel tank

### WELDER CONTROL PANEL

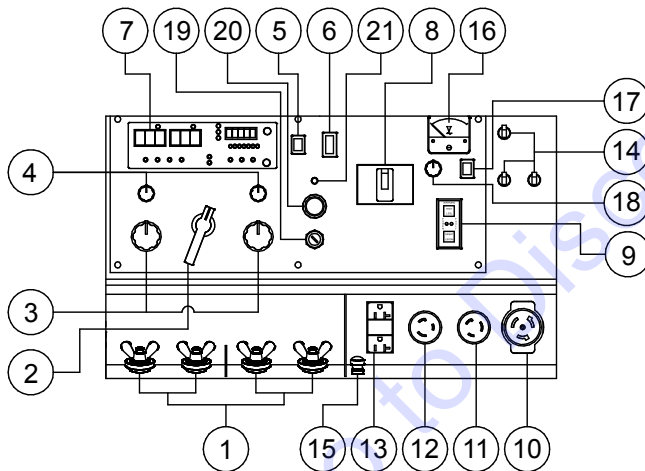

- |   |                                    |
|---|------------------------------------|
| 1. DC Welding Output Terminal           | 9. GFCI Sensing Module             |
| 2. Single - Dual Selector Switch        | 10. CS6369 Receptacles (120/240V)  |
| 3. Current/Voltage Regulator            | 11. L6-30R Receptacles (240V)      |
| 4. Arc Force Trimmer                    | 12. L5-30R Receptacles (120V)      |
| 5. Welding Mode Selector Switch (CC/CV) | 13. 5-20R Receptacles (120V, GFCI) |
| 6. E Mode Selector Switch               | 14. AC Circuit Breakers            |
| 7. Digital Panel:                       | 15. Ground Terminal (for GFCI)     |
| - DC Weld Meter                         | 16. AC Voltmeter                   |
| - Idle Stop Monitor                     | 17. Idle Stop Selector Switch      |
| - Hour Meter                            | 18. Time Regulator (SmartStick)    |
| - Fuel Meter                            | 19. Starter Switch                 |
| - Warning Lamp                          | 20. Engine Start Button            |
| 8. AC Circuit Breaker                   | 21. Operation Lamp                 |

### OPTIONAL TRAILER FEATURES

- **Lockable Trailer Storage Box** — ideal for securing welding cable, tools and supplies.
- **Cable Carriers** — Holds two 100 ft. lengths of 2/0 cable per side of trailer.
- **Coupler** — 2" ball, 2 5/16" ball and 3" pintle.
- **Spare Tire** — with lockable mounting bracket.



# DLW400ESA4

Welder

## UNIT ONLY DIMENSIONS

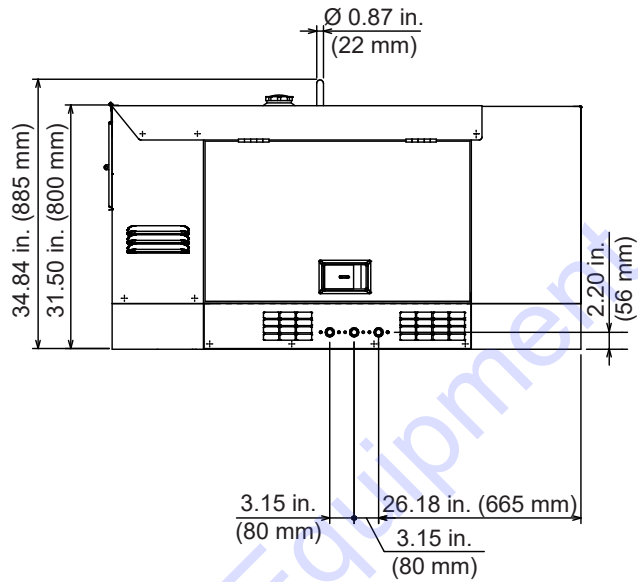
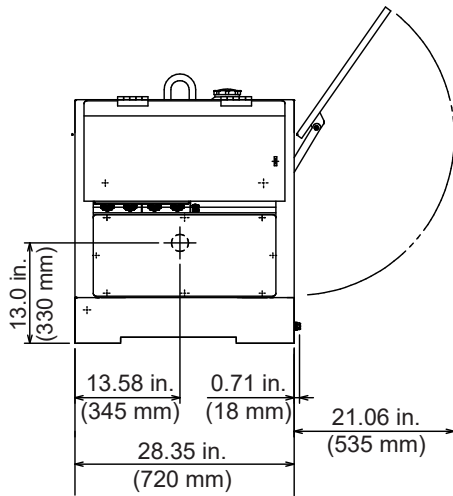

## TRAILER-MOUNTED DIMENSIONS

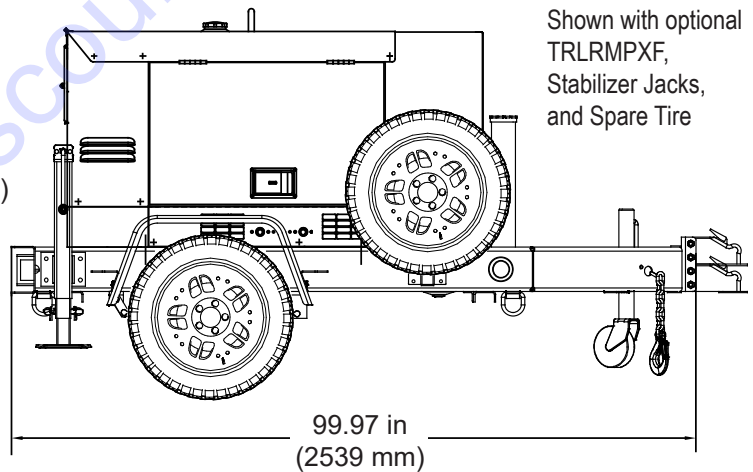
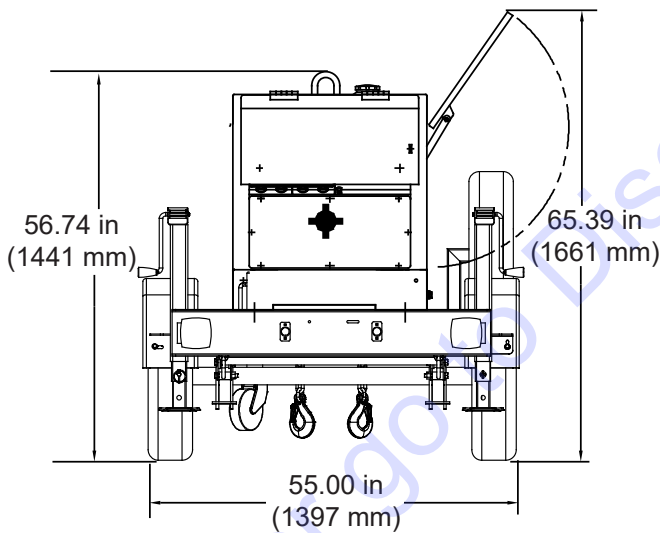

### DLW400ESA4 Weights\*

Dry Weight	1,026 lbs. (465 kg)
Wet Weight	1,143 lbs. (518 kg)
Max. Lifting Point Capacity	1,708 lbs. (775 kg)

\*Weights do not include options.

### DLW400ESA4 and TRLRMPXF Weights\*

Dry Weight (with TRLRMPXF)	1,540 lbs. (751 kg)
Wet Weight (with TRLRMPXF)	1,857 lbs. (842 kg)

Welder can be placed on MQ Power Model TRLRMP (XF) Trailer.

### NOTICE

Features and Specifications are subject to change without notice.



**TO PURCHASE THIS PRODUCT PLEASE CONTACT US**



**Equipment Financing and  
Extended Warranties Available**



**Discount-Equipment.com is your online resource for  
commercial and industrial quality parts and equipment sales.**

**561-964-4949**

**visit us on line @ [www.discount-equipment.com](http://www.discount-equipment.com)**

Select an option below to find your Equipment

**Search by Manufacturer**

**Search by Product Type**

**Request a Quote**

We sell worldwide for the brands: Genie, Terex, JLG, MultiQuip, Mikasa, Essick, Whiteman, Mayco, Toro Stone, Diamond Products, Generac Magnum, Airman, Haulotte, Barreto, Power Blanket, Nifty Lift, Atlas Copco, Chicago Pneumatic, Allmand, Miller Curber, Skyjack, Lull, Skytrak, Tsurumi, Husquvarna Target, Stow, Wacker, Sakai, Mi-T-M, Sullair, Basic, Dynapac, MBW, Weber, Bartell, Bennar Newman, Haulotte, Ditch Runner, Menegotti, Morrison, Contec, Buddy, Crown, Edco, Wyco, Bomag, Laymor, EZ Trench, Bil-Jax, F.S. Curtis, Gehl Pavers, Heli, Honda, ICS/PowerGrit, IHI, Partner, Imer, Clipper, MMD, Koshin, Rice, CH&E, General Equipment, Amida, Coleman, NAC, Gradall, Square Shooter, Kent, Stanley, Tamco, Toku, Hatz, Kohler, Robin, Wisconsin, Northrock, Oztec, Toker TK, Rol-Air, APT, Wylie, Ingersoll Rand / Doosan, Innovatech, Con X, Ammann, Mecalac, Makinex, Smith Surface Prep, Small Line, Wanco, Yanmar