



DIS100SSK4F

MQ POWER Air Compressor

CFM Rating — 95



STANDARD FEATURES

- Heavy duty, 4-cycle, direct injection, diesel engine provides maximum reliability.
- EPA emissions certified - Tier 4 final emissions compliant.
- Sound attenuated, weather resistant, steel housing provides operation at 70 dB(A) at 23 feet. Fully lockable enclosure allows safe unattended operation.
- Large side doors to provide access to engine and compressor.
- Bolt-on steel fender.
- D.O.T approved tail lamps, stop lamps, turn signal lamps and side marker lamps.
- Tongue mounted swivel jack with caster.
- 4-hole channel allows 3-position, adjustable coupler height; 4-inches O/A.
- Single-axle design with leaf spring suspension.
- E-coat and powder coat paint provide durability and weather protection.
- Controller provides readouts and warning lamps.

Readouts:

- Air Pressure Gauge
- Hour Meter
- Preheat
- Fuel Level

Warning Lamps (LED):

- Oil Pressure
- Water Temperature
- Charging
- Residual Tank Pressure
- Engine Low Speed
- Discharge Air Temperature



DIS100SSK4F

MQ POWER Air Compressor

SPECIFICATIONS

Air Compressor Specifications

Type	Rotary Screw
Rated Delivery	95 CFM (2.7 m ³ /min)
Rated Operating Pressure	100 psi (6.9 Bar)
Minimum Operation Pressure	73 psi (5.0 Bar)
Maximum Operation Pressure	120 psi (8.3 Bar)
Oil Capacity	3.3 gallons (12.5 liters)
Air Service Connections	Two 3/4" NPT
Cooling System	Oil Cooler
Air Cleaner (Air Compressor)	2-Stage Filter
Sound Level dB(A) Full Load at 23 Feet	70

Engine Specifications

Make / Model	Kubota / D1005-E4B
Emissions	Tier 4 Final Certified
Starting System	Electric
Design	4-cycle, Water Cooled, Direct Injection
Displacement	61.1 in ³ (1001 cc)
Gross Engine Power Output	24.4 HP
Engine Speed (RPM)	3200
Idle Speed (RPM)	2000
Oil Capacity	1.4 gallons (5.1 Liters)
Coolant Capacity	1.06 gallons (4.0 Liters)
Air Cleaner (Engine)	2-Stage Filter
Battery	12V, Group 24, CCA 650

Fuel System

Recommend Fuel	ASTM-D975-No. 1 & No. 2-D*	
Fuel Tank Capacity	10.6 gallons (40 liters)	
Fuel Consumption	gph	lph
At full load	1.61	6.1
At 1/2 load	1.16	4.4

* Ultra low Sulfur Diesel Fuel

Trailer Specifications

Gross Axle Weight Rating (GAWR)	2500 lbs. (1334 kg)
Tire Size	ST175/80D13 LR-C
Tow Bar Design	Bolt on "A" Frame
Jack Stand type	Caster

NOTICE

Specifications sheet is subject to change and is not intended for use in installation design.



DIS100SSK4F

MQ POWER Air Compressor

MQ POWER DECIBEL LEVELS

Our soundproof housing allows substantially lower operating noise levels than competitive designs. DIS100SSK4F is at home on construction sites, in residential neighborhoods, and at hospitals — just about anywhere.

- 90 — Subway / truck traffic
- 80 — Average city traffic
- 70 — **DIS100SSK4F at 23 feet**
- 60 — Air conditioner at 20 feet
- 50 — Normal conversation

70.0
DECIBELS

Coupler Options

2" Ball Coupler
10,000 lbs. (4,536 kg)

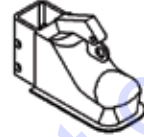

#EE43254

2-5/16" Ball Coupler
14,000 lbs. (6,350 kg)

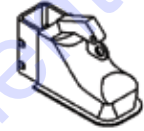

#EE43253

3" Pintle Eye
25,000 lbs. (11,340 kg)



#EE36264

CONTROL PANEL

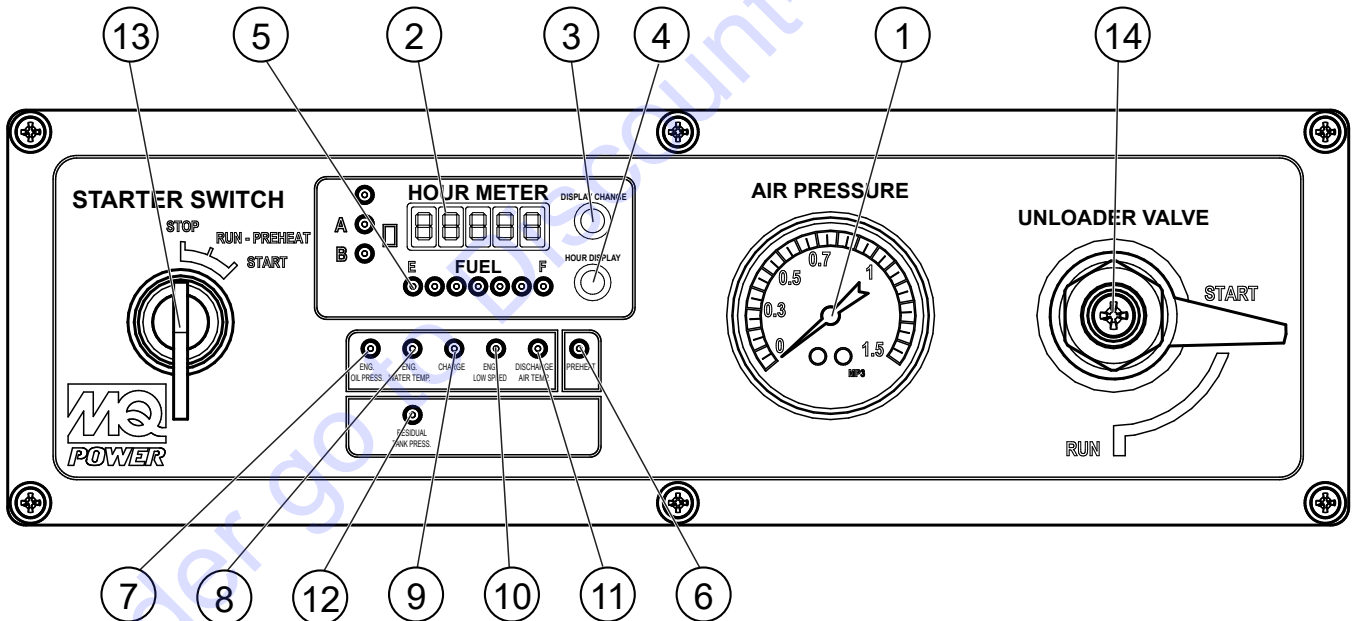

- | | |
|--|--|
| 1. Delivery Air Pressure Gauge | 8. Water Temperature Warning Lamp |
| 2. Hour Meter | 9. Charging Warning Lamp |
| 3. Hour Meter Select Switch | 10. Engine Low Speed Warning Lamp |
| 4. Hour Meter Check Switch | 11. Discharge Air Temperature Warning Lamp |
| 5. Fuel Level Gauge | 12. Residual Tank Pressure Starting Lamp |
| 6. Preheat Lamp | 13. Starter Switch |
| 7. Engine Lube Oil Pressure Warning Lamp | 14. Unloader Valve |



DIS100SSK4F

MQ POWER Air Compressor

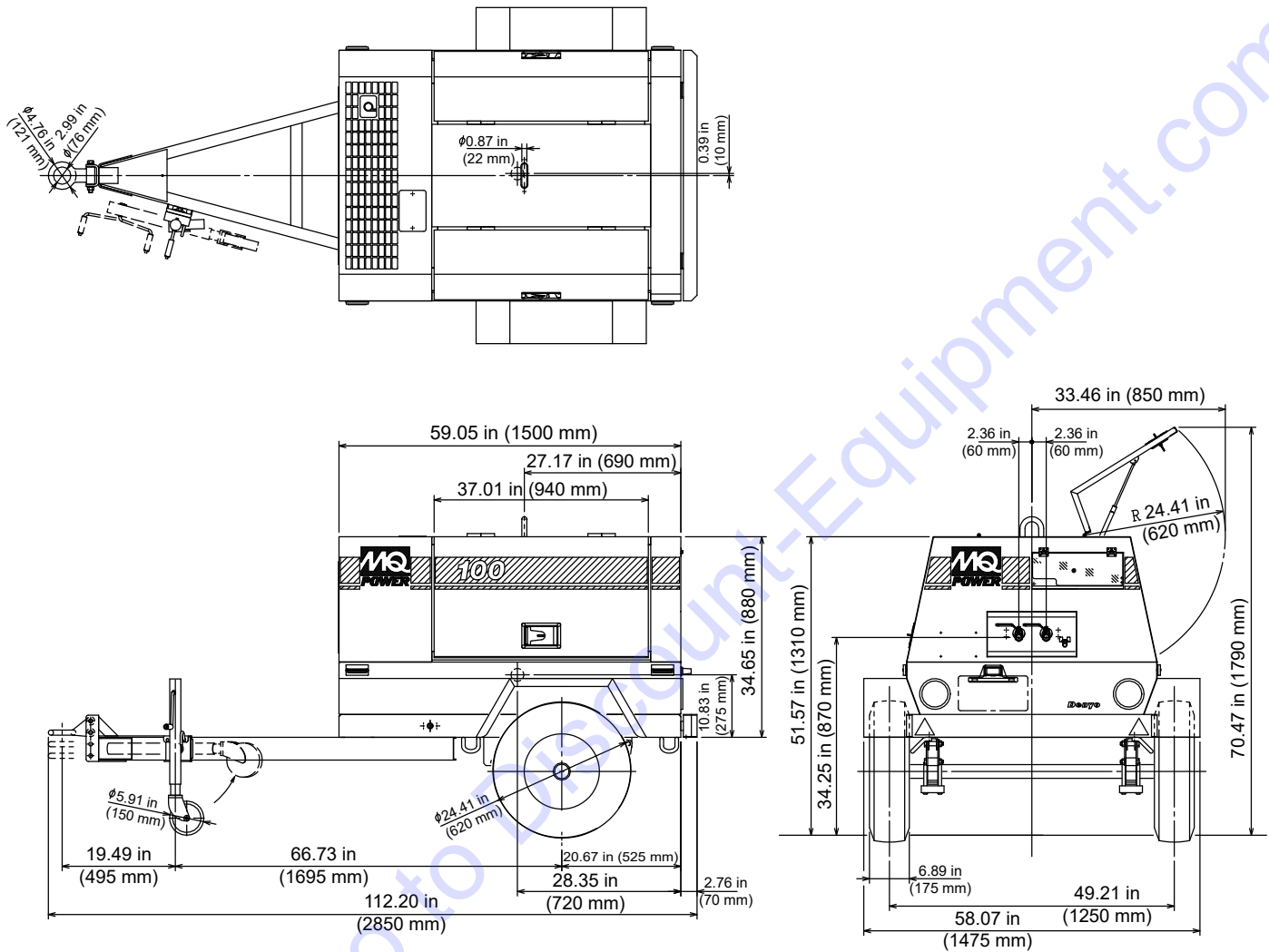

DIS100SSK4F Weights

Dry Weight	1,521.19 lbs. (690 kg)
Wet Weight	1,631.42 lbs. (740 kg)
Max. Lifting Point Capacity	1,650 lbs. (748 kg)

NOTICE

Features and Specifications are subject to change without notice.



TO PURCHASE THIS PRODUCT PLEASE CONTACT US



**Equipment Financing and
Extended Warranties Available**



**Discount-Equipment.com is your online resource for
commercial and industrial quality parts and equipment sales.**

561-964-4949

visit us on line @ www.discount-equipment.com

Select an option below to find your Equipment

Search by Manufacturer

Search by Product Type

Request a Quote

We sell worldwide for the brands: Genie, Terex, JLG, MultiQuip, Mikasa, Essick, Whiteman, Mayco, Toro Stone, Diamond Products, Generac Magnum, Airman, Haulotte, Barreto, Power Blanket, Nifty Lift, Atlas Copco, Chicago Pneumatic, Allmand, Miller Curber, Skyjack, Lull, Skytrak, Tsurumi, Husquvarna Target, Stow, Wacker, Sakai, Mi-T-M, Sullair, Basic, Dynapac, MBW, Weber, Bartell, Bennar Newman, Haulotte, Ditch Runner, Menegotti, Morrison, Contec, Buddy, Crown, Edco, Wyco, Bomag, Laymor, EZ Trench, Bil-Jax, F.S. Curtis, Gehl Pavers, Heli, Honda, ICS/PowerGrit, IHI, Partner, Imer, Clipper, MMD, Koshin, Rice, CH&E, General Equipment, Amida, Coleman, NAC, Gradall, Square Shooter, Kent, Stanley, Tamco, Toku, Hatz, Kohler, Robin, Wisconsin, Northrock, Oztec, Toker TK, Rol-Air, APT, Wylie, Ingersoll Rand / Doosan, Innovatech, Con X, Ammann, Mecalac, Makinex, Smith Surface Prep, Small Line, Wanco, Yanmar