



**Count on it.**

**Parts Catalog**

**CM-250E-PWB Concrete Mixer**

Model No. 68003—Serial No. 313000001 and Up



# Concrete Mixer Assembly with Stand

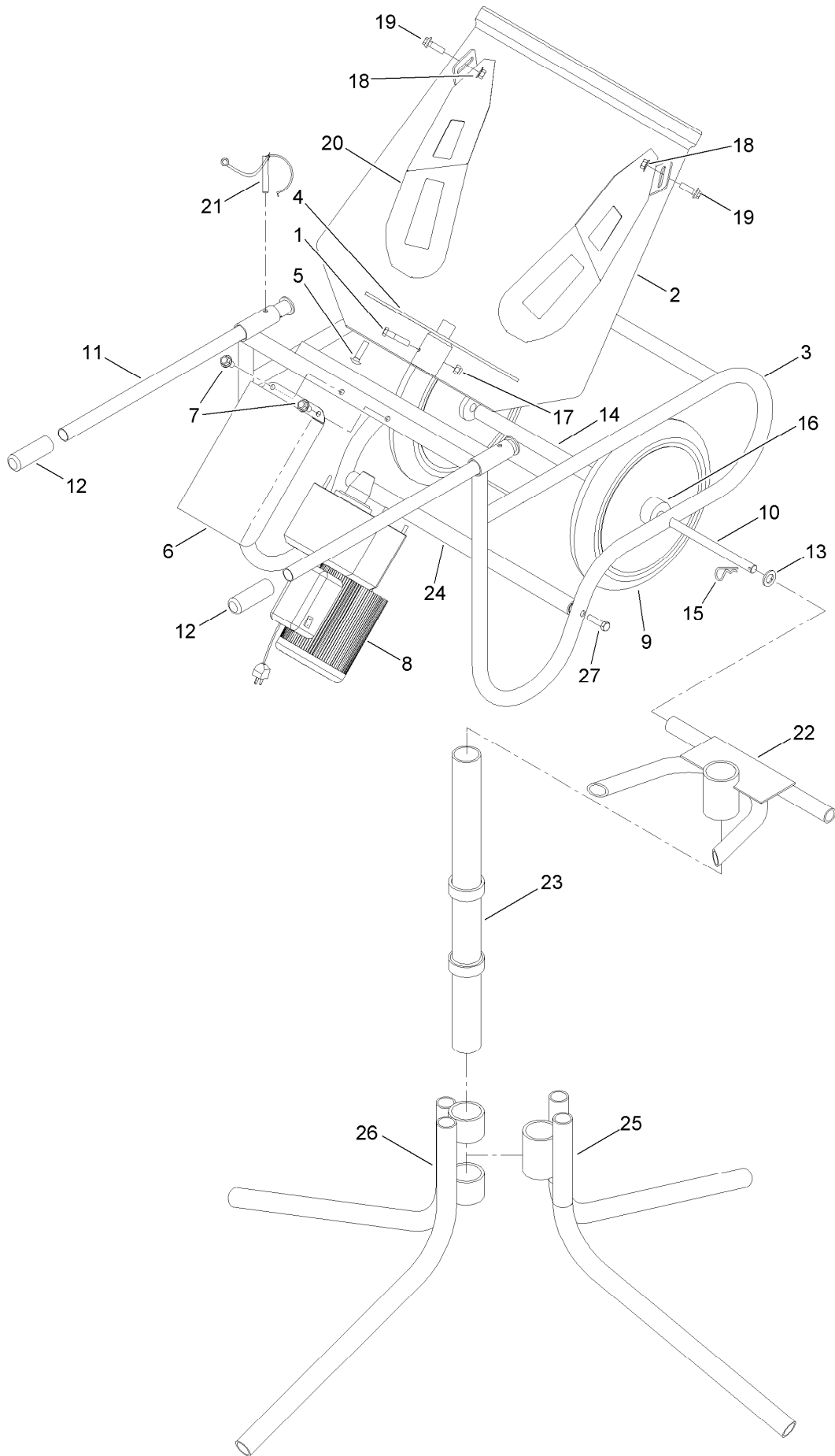

## Concrete Mixer Assembly with Stand (continued)

<i>Ref.</i>	<i>Part Number</i>	<i>Qty.</i>	<i>Description</i>	<i>Ref.</i>	<i>Part Number</i>	<i>Qty.</i>	<i>Description</i>
1	127-5527	1	Bolt	17	3290-357	13	Nut-HHF, Whiz
2	127-5528	1	Drum-Polyethylene	18	32128-20	4	Nut-HF
3	127-5529	1	Frame-Wheelbarrow	19	3234-17	2	Screw-HHF
4	127-5530	1	Inside Plate ASM (W/ Straight Bushing)	20	127-5540	2	Blade-Mixing
5	3234-18	12	Screw-HHF	21	127-5541	2	Pin-Locking (W/ Lanyards)
6	127-5531	1	Cover-Motor	22	127-5542	1	Brace-Support, Tri-Pod Stand
7	127-5532	2	Screw-Whizlock	23	127-5543	1	Support-Vertical, Tri-Pod Stand
8	127-5533	1	Gear Motor ASM	24	127-5544	1	Bracket-Horizontal, Tri-Pod Stand
9	127-5534	2	Flat Free Wheel ASM	25	127-5545	1	Pipe-Support, Leg 1 (Tri-Pod Stand)
10	127-5547	1	Axle	26	127-5546	1	Pipe-Support, Leg 2 (Tri-Pod Stand)
11	127-5535	2	Handle-Frame	27	3234-18	1	Screw-HHF
12	127-5536	2	Grip-Handle				
13	1-303007	2	Washer				
14	127-5537	1	Spacer-Tube, Axle				
15	127-5538	2	Clip-R				
16	127-5539	4	Bearing-Wheel				



**Count on it.**