

### ENGINE SYSTEM

- Mitsubishi® L2E
- Diesel fueled
- EPA Tier 4 Final
- 2 cylinder
- 0.635 L displacement
- Power @ 1,800 rpm: 7.1 hp (5.2 kW)
- Air filter: Dry type cartridge

### Fuel System

- Tank usable capacity: 39.9 gal (151.04 L)
- Run time – hr:
 

	Standard	Export Power Option
• Lights only:	162*	165*
• 100% load:	NA	144*
- Fuel consumption – gph (Lph):
 

	Standard	Export Power Option
• Lights only:	0.25 (0.95)*	0.24 (0.91)
• 100% load:	NA	0.28 (1.06)
- Fill port diameter: 3.5 in (89 mm)

### Cooling System

- Liquid cooled

### Lubrication System

- Oil filter: Full flow, spin-on type
- 1,000-hr service interval\*\*†

\*Data based on engine manufacturer and field test data after 50-hr engine break-in period. Actual results may vary, according to factors such as age and maintenance of equipment, environmental conditions, and fuel density. For fuel and maintenance recommendations, see owner's manual.

\*\*For maximum service interval, replace oil filter after 50-hr break-in period. For oil filter model number, see owner's manual.

†Air and fuel filter vary, according to environmental factors.

### GENERATOR

- 60 Hz
- Marathon Electric® brushless

### SYSTEM

- |                       | Standard | Export Power Option |
|-----------------------|----------|---------------------|
| • System rating – kW: | 1.4      | 2.4                 |
| • Receptacle rating:  | NA       | 20 A/120 V          |

### CONTROLS

- Illuminated control panel with sealed switches
- Key-activated switch with 4 positions (GLOW PLUG, OFF, RUN, START)
- Digital hour meter
- Automatic shutdown for low oil pressure and high coolant temperature
- One switch controls all light fixtures



Picture shown may not reflect actual configuration.

### FLOODLIGHTS

- Four 320 W LED (G4) fixtures
- Aluminum and polymer housing
- Efficiency: 147 LPW
- Lm/fixture: 47,000
- Total lm: 188,000
- Coverage at 0.5 ft-c: 24,060 ft<sup>2</sup> (2,235 m<sup>2</sup>)
- IP68 LED modules; IP65 rated drivers
- Fixture-mounted drivers

### ELECTRICAL SYSTEM

- Start trip breaker (ensures no-load condition exists at start-up)
- Floodlight circuits with sealed breakers
- Wiring is sized and fused to required amperage draw
- 440 CCA wet cell battery

### MAST

- Vertical operation and storage
- Five tubular steel sections with polymer guides
- Winch: Dual handle, manual crank, self-braking
- Distinctive angled fixture mount for common light distribution
- 359° rotation, lockable and adjustable from ground
- Industrial-black powder-coat
- Self-retracting, coiled mast cord

### ENCLOSURE

- Hood:
  - Injection-molded with UV protected colorant
  - Flip-up design for ease of service
- Sound rating: 67 dB(A) at 23 ft (7 m) – lights only
- Lifting point and fork pockets
- Multi-lingual operating and safety decals
- Illuminated license plate holder
- Document holder with owner's manual – includes AC and DC wiring diagrams

### TRAILER

- Tubular steel frame
- 2 in (50.8 mm) ball hitch
- Three 1,200 lb (544 kg) tube-and-sleeve leveling jacks – lockable into stowed positions
- Side outriggers
- 7,800 lb (3,538 kg) safety chains with spring loaded safety hooks
- Removable and foldable tongue – 48 in (121.9 cm) long
- DOT approved LED lights: Tail, side, brake, and directionals
- 2,200 lb (998 kg) leaf spring axle
- Tires: ST175/80D13, 6 ply

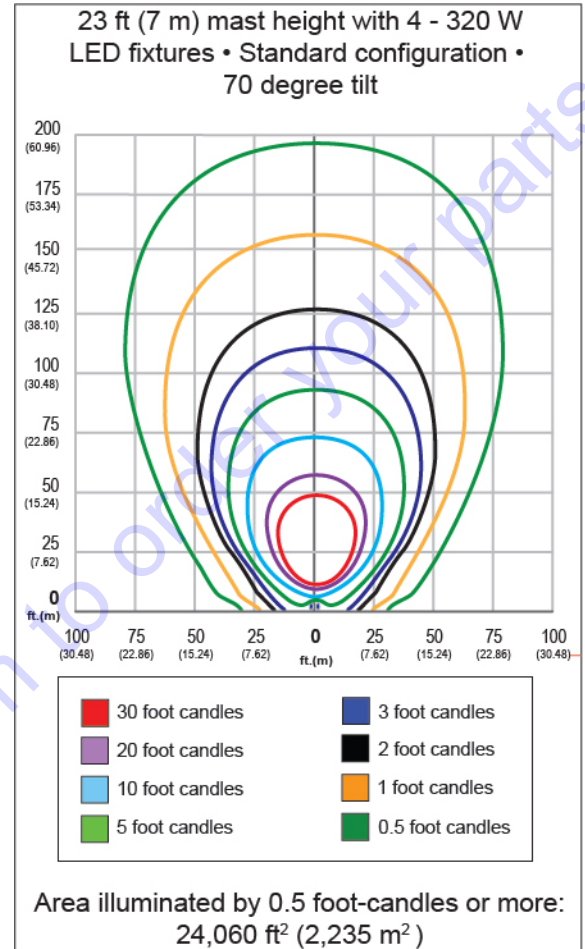

**OPTIONS**

- Electric winch
- Winch cover
- Positive air shutdown
- 2.4 kW export power – 20 A × 120 V duplex
- Import power
- Containment (oil and coolant)
- Tandem tow
- Battery charger
- Battery disconnect
- 60/40 coolant
- Diffused LEDs
- Diffused LED lens storage
- Autolight digital controller
- Lower radiator hose heater
- Fuel filter heater
- Flat 4 to round 7 spade

**DIMENSIONS**

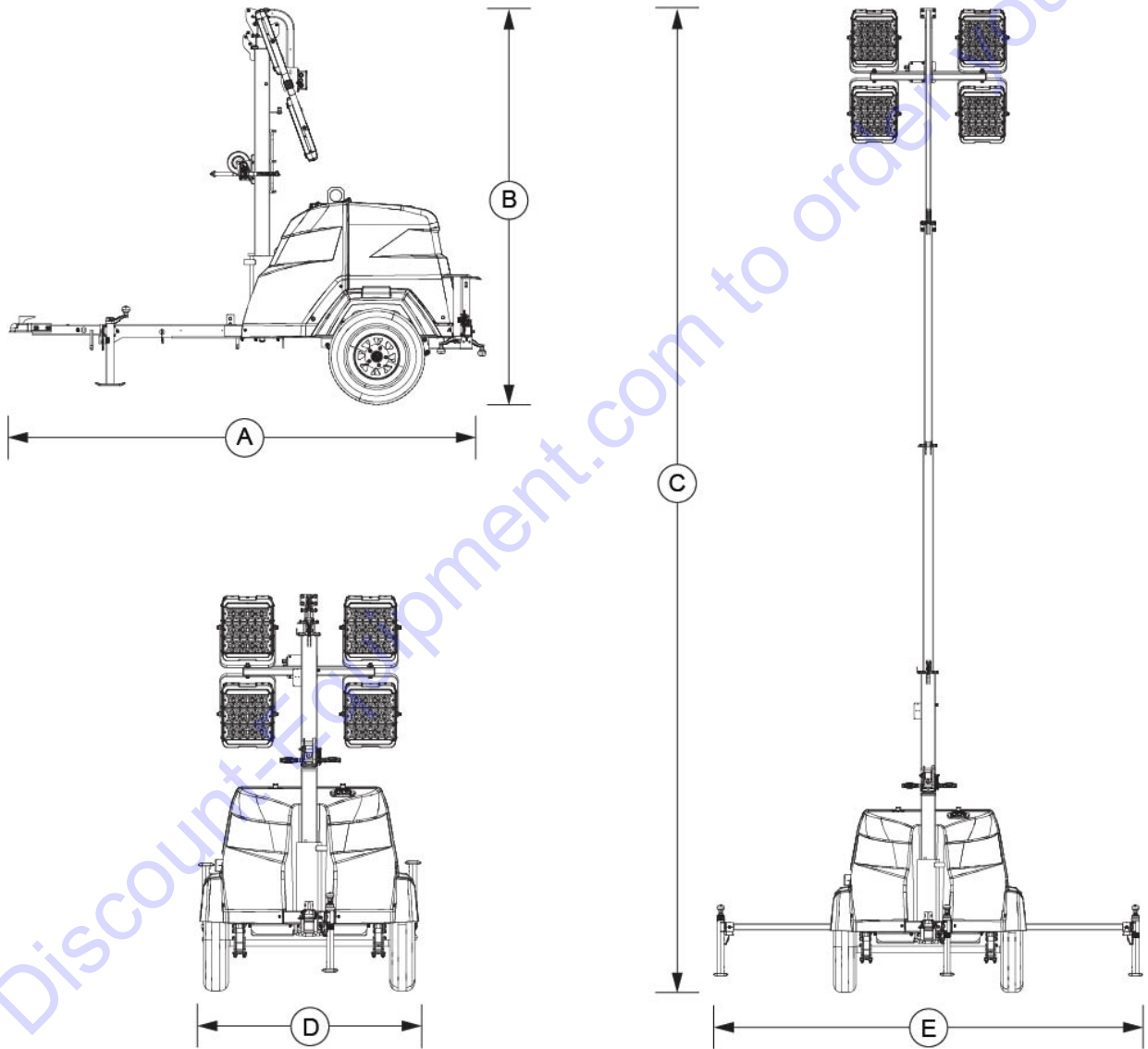

009807

A	B	C	D	E
118 in (3 m)	101 in (2.6 m)	23 ft (7 m)	57 in (1.45 m)	10 ft (3.05 m)

**WEIGHT**

- |              | <u>Standard</u>     | <u>Export Power Option</u> |
|--------------|---------------------|----------------------------|
| • Dry:       | 1,110 lb (503.5 kg) | 1,185 lb (537.5 kg)        |
| • Operating: | 1,415 lb (641.8 kg) | 1,440 lb (653.2 kg)        |



**AMBIENT CLIMATE RATINGS**

- Wind rating: 65 mph (105 km/h)
- Air temperature ratings:
  - Standard units: 0 °F to 120 °F (-18 °C to 49 °C)
  - Units equipped with cold-weather options: -18 °F to 120 °F (-28 °C to 49 °C)

**WARRANTY**

- Tower: 1 year, unlimited hours/2 years, 2,000 hours
- LED modules and drivers: 5 year limited warranty

**CERTIFICATIONS**

- CSA certified

Go to [Discount-Equipment.com](http://Discount-Equipment.com) to order your parts

**TO PURCHASE THIS PRODUCT PLEASE CONTACT US**



**Equipment Financing and  
Extended Warranties Available**



**Discount-Equipment.com is your online resource for  
commercial and industrial quality parts and equipment sales.**

**561-964-4949**

**visit us on line @ [www.discount-equipment.com](http://www.discount-equipment.com)**

Select an option below to find your Equipment

**Search by Manufacturer**

**Search by Product Type**

**Request a Quote**

We sell worldwide for the brands: Genie, Terex, JLG, MultiQuip, Mikasa, Essick, Whiteman, Mayco, Toro Stone, Diamond Products, Generac Magnum, Airman, Haulotte, Barreto, Power Blanket, Nifty Lift, Atlas Copco, Chicago Pneumatic, Allmand, Miller Curber, Skyjack, Lull, Skytrak, Tsurumi, Husquvarna Target, Stow, Wacker, Sakai, Mi-T-M, Sullair, Basic, Dynapac, MBW, Weber, Bartell, Bennar Newman, Haulotte, Ditch Runner, Menegotti, Morrison, Contec, Buddy, Crown, Edco, Wyco, Bomag, Laymor, EZ Trench, Bil-Jax, F.S. Curtis, Gehl Pavers, Heli, Honda, ICS/PowerGrit, IHI, Partner, Imer, Clipper, MMD, Koshin, Rice, CH&E, General Equipment, Amida, Coleman, NAC, Gradall, Square Shooter, Kent, Stanley, Tamco, Toku, Hatz, Kohler, Robin, Wisconsin, Northrock, Oztec, Toker TK, Rol-Air, APT, Wylie, Ingersoll Rand / Doosan, Innovatech, Con X, Ammann, Mecalac, Makinex, Smith Surface Prep, Small Line, Wanco, Yanmar