

Parts List
for Portable Generators
English

CPG 20-25 KD



Engine V2403M

CPG 20-25 KD

Engine 2403M

Parts Index	5
Warranty and Liability	7
Safety Precautions for Portable compressors.....	9
Ordering Spare Parts.....	8
Parts Lists	15

PARTS INDEX

PART	PAGE	PART	PAGE	PART	PAGE
A		COVER RED BATTERY CONNECTOR	26	FUSE HOLDER	30, 31
ADAPTER	28, 38	CUBICLE ASSEMBLY	30, 31	G	
AIR FILTER	18	CUBICLE DOOR	43	GENCOOL	16
AIR INLET	18	CUBICLE PANEL	30, 31	GENOIL	17
ALTERNATOR	22	CURRENT TRANSFORMER	30, 31	GROMMET	38
ALTERNATOR AND ACCESSORIES	22, 23	D		GUARD	20
AMMETER	53	DIN RAIL	30	H	
AXLE ASSEMBLY	58	DOOR	30, 43, 47, 48	HANDGRIP	53
B		DOOR ASSEMBLY	24, 43, 47, 48	HANDLE	43, 47, 48
BAFFLE AIR INLET	24	DOOR CUBICLE	43, 53	HARTING HOUSING	30
BAFFLE ASSEMBLY	52	DOOR CUBICLE ASSEMBLY	24, 43	HEXAGON PLUG	28, 36
BALL VALVE	28	DOOR PLATE	30	HINGE	40, 43, 44, 45, 46, 47, 48
BATTERY	56	DOOR TERMINAL	31	HOLDER DOCUMENT	24
BATTERY CABLE	56	DRAINS	28	HORIZONTAL LIFTING BEAM	24
BATTERY CHARGER	56	E		HOSE	38
BATTERY SWITCH	60	EARTH RAIL ASSEMBLY	30, 31	HOSE ASSEMBLY ENGINE OIL DRAIN	28
BODYWORK	24, 25	ELECTRICAL SYSTEM	26, 27, 56, 57	HOSE CLAMP	20, 38
C		ELEMENT	18	HOSE CLIP	38, 54
CABLE GLAND	20, 30, 31	EMERGENCY STOP	30	HUMP HOSE	20
CABLE TIE	56	ENGINE	19	I	
CABLE TY	24, 26	ENGINE AND ACCESSORIES	19	INFORMATION LABEL	54
CANOPY SET	24	ENGINE COOLANT	16	INSERT MALE	31
CAP	24, 38	ENGINE OIL	17	INSULATOR TERMINAL	26, 56
CIRCUIT BREAKER	30, 31	E-STOP	31	J	
CLAMP	26, 29, 36, 56	EXHAUST MUFFLER	29	JACK TOUNGUE	58
CLAMP HOSE	18	EXHAUST SYSTEM	29	K	
CONTACT	53	F		KEY ATLAS COPCO SPEC	24
CONTACT MALE	31	FAN BOX	20	L	
CONTACTOR	30, 31	FENDER	58	LABEL CALIFORNIA EMISSIONS	32, 34
CONTROL PANEL ASSEMBLY	30, 31, 53	FILTER FUEL	38	LABEL CAUTION HOT EXHAUST	32, 34
CONTROLLER	53	FLANGE	36	LABEL COOLANT MUST MEET	32, 34
COOLANT RECOVERY BOTTLE	20	FOOT ENGINE	19	LABEL CP INTERNET	32, 34
COOLER	20	FRAME	36, 58	LABEL CP LOGO	32, 34
COOLING SYSTEM	20, 21	FRAME AND MOUNTS	36, 37	LABEL HIGH VOLTAGE	32, 34
CORNER	44, 45, 46	FUEL FILTER	38	LABEL LOGO	45, 46
CORNER ASSEMBLY	24, 40, 44, 45, 46	FUEL FILTER HOUSING	38		
CORNER CUBICLE	40	FUEL HOSE	20, 38, 54		
COVER	38, 53	FUEL SYSTEM	38, 39		
COVER BATTERY CABLE	56	FUELTANK	38		
COVER COOLER	49	FUSE	30, 31, 53		

PARTS INDEX

PART	PAGE	PART	PAGE	PART	PAGE
L					
LABEL NEUTRAL GROUNDED.....	32, 34	RUBBER ELBOW	18		
LABEL OIL FILL TYPE.....	32, 34	S			
LABEL OPERATING INSTRUCTION	32, 34	SAFETY CARTRIDGE.....	18		
LABEL QC1002 OPERATING	32, 34	SAFETY CHAIN.....	58		
LABEL RELAY FUNCTION.....	32, 34	SENSOR LEVEL.....	38		
LABEL SELECTOR SW POSITION	32, 34	SERVICE PAK.....	14, 15		
LABEL SELECTOR SW VOLTAGES	32, 34	SHIELD	36		
LABEL SERVICE PAKS.....	32, 34	SHIELD EXHAUST PIPE	29		
LABEL WARNING ALTERNATOR.....	32, 34	SHUNT TRIP.....	30		
LABEL WARNING-UNIT	32, 34	SOCKET	30, 53		
LAMP	53	SPACER DOOR CATCH	41, 42		
LATCH DOOR	31	SUPPORT	22, 36, 49, 50, 54		
LIGHT MARKER.....	58	SUPPORT AIR INLET.....	18		
LIFTING BEAM ASSEMBLY.....	24, 41, 42	SWITCH	53		
M					
MARKINGS	32, 33, 34, 35	SWITCH SELECTOR	22		
MODEL DESIGNATION	32, 34	T			
P					
PANEL ASSEMBLY SERVICE	24	TAIL LIGHT.....	58		
PANEL SERVICE.....	51	TAIL LIGHT ASSEMBLY	58		
PANEL LIGHT	53	TERMINAL	30, 31		
PIPE EXHAUST.....	29	TERMINAL BORAD.....	30, 31		
PIPE RADIATOR	20	TIRE AND WHEEL ASSEMBLY	58		
PLASTIC TUBE	20, 38	TOWING EYE.....	58		
PLATE	20, 22, 36	TRAILER ASSEMBLY.....	58, 59		
PLATE AIR DIVERTER	24	TRIP COIL.....	31		
PLATE CUBICLE CORNER	40	TUBE	20		
PLUG.....	30, 31, 38	TUBE AIR INLET.....	18		
POTMETER	53	V			
PROTECTION	31	VALVE.....	54		
PTFE TUBE.....	38	VALVE AND FITTINGS	54, 55		
R					
RAIL	31	VERT LIFTING BEAM	24, 41, 42		
RAINCAP	29	VIBRATION MOUNT	19, 22		
RECEPTACLE.....	30, 31	VOLTMETER	53		
RELAY	26, 30, 31, 53, 56	W			
ROOF.....	49, 50	WINDOW CUBICLE DOOR	43		
ROOF ASSEMBLY.....	24, 49, 50	WIRE HARNESS	26, 56, 58		
		WIRE SET	22		

Warranty and Liability Limitation

Use only authorized parts.

Any damage or malfunction caused by the use of unauthorized parts is not covered by Warranty or Product Liability.

The manufacturer does not accept any liability for any damage arising for modifications, additions or conversions made without the manufacturer's approval in writing.

Copyright 2012, Chicago Pneumatic

Any unauthorized use or copying of the contents or any part thereof is prohibited.

This applies in particular to trademarks, model denominations, part numbers and drawings

Limitation de garantie et de responsabilité

Utiliser uniquement les pièces homologuées.

Tout dommage ou mauvais fonctionnement dû à l'utilisation de pièces non homologuées n'est pas couvert par la garantie ou la responsabilité des produits défectueux.

Le fabricant décline toute responsabilité en cas de dommage faisant suite à des modifications, des ajouts ou des conversions effectués sans l'accord écrit du fabricant.

Copyright 2012, Chicago Pneumatic

Toute utilisation ou copie du contenu, ou d'une partie de celui-ci, non autorisée est interdite.

Cette interdiction s'applique en particulier aux marques de commerce, aux dénominations des modèles, aux numéros des pièces et aux schémas.

Limitación de garantía y responsabilidad

Use sólo piezas autorizadas.

La garantía o responsabilidad del producto no cubre ningún daño o funcionamiento defectuoso provocado por el uso de piezas no autorizadas.

El fabricante no acepta ninguna responsabilidad por los daños provocados por modificaciones, adiciones o conversiones realizadas sin la aprobación por escrito del fabricante.

Derechos de reproducción 2012, Chicago Pneumatic,

Está prohibida toda utilización o reproducción total o parcial no autorizada de estos contenidos,

en especial de las marcas registradas, denominaciones de modelos, números de piezas y planos

SAFETY PRECAUTIONS FOR PORTABLE GENERATORS

To be read attentively and acted accordingly before towing, lifting, operating, performing maintenance or repairing the generator

0.1 INTRODUCTION

The policy of Chicago Pneumatic is to provide the users of their equipment with safe, reliable and efficient products. Factors taken into account are among others:

- the intended and predictable future use of the products, and the environments in which they are expected to operate,
- applicable rules, codes and regulations,
- the expected useful product life, assuming proper service and maintenance,
- providing the manual with up-to-date information.

Before handling any product, take time to read the relevant instruction manual. Besides giving detailed operating instructions, it also gives specific information about safety, preventive maintenance, etc.

Keep the manual always at the unit location, easy accessible to the operating personnel.

See also the safety precautions of the engine and possible other equipment, which are separately sent along or are mentioned on the equipment or parts of the unit.

These safety precautions are general and some statements will therefore not always apply to a particular unit.

Only people that have the right skills should be allowed to operate, adjust, perform maintenance or repair on Chicago Pneumatic equipment. It is the responsibility of management to appoint operators with the appropriate training and skill for each category of job.

Skill level 1: Operator

An operator is trained in all aspects of operating the unit with the push-buttons, and is trained to know the safety aspects.

Skill level 2: Mechanical technician

A mechanical technician is trained to operate the unit the same as the operator. In addition, the mechanical technician is also trained to perform maintenance and repair, as described in the instruction manual, and is allowed to change settings of the control and safety system. A mechanical technician does not work on live electrical components.

Skill level 3: Electrical technician

An electrical technician is trained and has the same

qualifications as both the operator and the mechanical technician. In addition, the electrical technician may carry out

electrical repairs within the various enclosures of the unit. This includes work on live electrical components.

Skill level 4: Specialist from the manufacturer

This is a skilled specialist sent by the manufacturer or its agent to perform complex repairs or modifications to the equipment.

In general it is recommended that not more than two people operate the unit, more operators could lead to unsafe operating conditions. Take necessary steps to keep unauthorized persons away from the unit and eliminate all possible sources of danger at the unit.

When handling, operating, overhauling and/or performing maintenance or repair on Chicago Pneumatic equipment, the mechanics are expected to use safe engineering practices and to observe all relevant local safety requirements and ordinances. The following list is a reminder of special safety directives and precautions mainly applicable to Chicago Pneumatic equipment.

Neglecting the safety precautions may endanger people as well as environment and machinery:

- endanger people due to electrical, mechanical or chemical influences,
- endanger the environment due to leakage of oil, solvents or other substances,
- endanger the machinery due to function failures.

All responsibility for any damage or injury resulting from neglecting these precautions or by non-observance of ordinary caution and due care required in handling, operating, maintenance or repair, also if not expressly mentioned in this instruction manual, is disclaimed by Chicago Pneumatic.

The manufacturer does not accept any liability for any damage arising from the use of non-original parts and for modifications, additions or conversions made without the manufacturer's approval in writing.

If any statement in this manual does not comply with local legislation, the stricter of the two shall be applied.

Statements in these safety precautions should not be interpreted as suggestions, recommendations or inducements that it should be used in violation of any

applicable laws or regulations.

0.2 GENERAL SAFETY PRECAUTIONS

- 1 The owner is responsible for maintaining the unit in a safe operating condition. Unit parts and accessories must be replaced if missing or unsuitable for safe operation.
- 2 The supervisor, or the responsible person, shall at all times make sure that all instructions regarding machinery and equipment operation and maintenance are strictly followed and that the machines with all accessories and safety devices, as well as the consuming devices, are in good repair, free of abnormal wear or abuse, and are not tampered with.
- 3 Whenever there is an indication or any suspicion that an internal part of a machine is overheated, the machine shall be stopped but no inspection covers shall be opened before sufficient cooling time has elapsed; this to avoid the risk of spontaneous ignition of oil vapour when air is admitted.
- 4 Normal ratings (pressures, temperatures, speeds, etc.) shall be durably marked.
- 5 Operate the unit only for the intended purpose and within its rated limits (pressure, temperature, speeds, etc.).
- 6 The machinery and equipment shall be kept clean, i.e. as free as possible from oil, dust or other deposits.
- 7 To prevent an increase in working temperature, inspect and clean heat transfer surfaces (cooler fins, intercoolers, water jackets, etc.) regularly. See the maintenance schedule.
- 8 All regulating and safety devices shall be maintained with due care to ensure that they function properly. They may not be put out of action.
- 9 Pressure and temperature gauges shall be checked regularly with regard to their accuracy. They shall be replaced whenever outside acceptable tolerances.
- 10 Safety devices shall be tested as described in the maintenance schedule of the instruction manual to determine that they are in good operating condition.
- 11 Mind the markings and information labels on the unit.
- 12 In the event the safety labels are damaged or destroyed, they must be replaced to ensure operator safety.

- 13 Keep the work area neat. Lack of order will increase the risk of accidents.
- 14 When working on the unit, wear safety clothing. Depending on the kind of activities these are: safety glasses, ear protection, safety helmet (including visor), safety gloves, protective clothing, safety shoes. Do not wear the hair long and loose (protect long hair with a hairnet), or wear loose clothing or jewelry.
- 15 Take precautions against fire. Handle fuel, oil and anti-freeze with care because they are inflammable substances. Do not smoke or approach with naked flame when handling such substances. Keep a fire-extinguisher in the vicinity.
- 16a **Portable generators (with earthing pin):**
Earth the generator as well as the load properly.
- 16b **Portable generators IT:**
Note: This generator is built to supply a sheer alternating current IT network.
Earth the load properly.

0.3 SAFETY DURING TRANSPORT AND INSTALLATION

To lift a unit, all loose or pivoting parts, e.g. doors and towbar, shall first be securely fastened.

Do not attach cables, chains or ropes directly to the lifting eye; apply a crane hook or lifting shackle meeting local safety regulations. Never allow sharp bends in lifting cables, chains or ropes.

Helicopter lifting is not allowed.

It is strictly forbidden to dwell or stay in the risk zone under a lifted load. Never lift the unit over people or residential areas. Lifting acceleration and retardation shall be kept within safe limits.

- 1 Before towing the unit:
 - check the towbar, the brake system and the towing eye. Also check the coupling of the towing vehicle,
 - check the towing and brake capability of the towing vehicle,
 - check that the towbar, jockey wheel or stand leg is safely locked in the raised position,
 - ascertain that the towing eye can swivel freely on the hook,
 - check that the wheels are secure and that the tyres are in good condition and inflated correctly,
 - connect the signalisation cable, check all lights and connect the pneumatic brake couplers,
 - attach the safety break-away cable or safety chain to the towing vehicle,
 - remove wheel chocks, if applied, and disengage the parking brake.
- 2 To tow a unit use a towing vehicle of ample capacity. Refer to the documentation of the towing vehicle.
- 3 If the unit is to be backed up by the towing vehicle, disengage the overrun brake mechanism (if it is not an automatic mechanism).
- 4 Never exceed the maximum towing speed of the unit (mind the local regulations).
- 5 Place the unit on level ground and apply the parking brake before disconnecting the unit from the towing vehicle. Unclip the safety break-away cable or safety chain. If the unit has no parking brake or jockey wheel, immobilize the unit by placing chocks in front of and/or behind the wheels. When the towbar can be positioned vertically, the locking device must be applied and kept

in good order.

- 6 To lift heavy parts, a hoist of ample capacity, tested and approved according to local safety regulations, shall be used.
- 7 Lifting hooks, eyes, shackles, etc., shall never be bent and shall only have stress in line with their design load axis. The capacity of a lifting device diminishes when the lifting force is applied at an angle to its load axis.
- 8 For maximum safety and efficiency of the lifting apparatus all lifting members shall be applied as near to perpendicular as possible. If required, a lifting beam shall be applied between hoist and load.
- 9 Never leave a load hanging on a hoist.
- 10 A hoist has to be installed in such a way that the object will be lifted perpendicular. If that is not possible, the necessary precautions must be taken to prevent load-swinging, e.g. by using two hoists, each at approximately the same angle not exceeding 30° from the vertical.
- 11 Locate the unit away from walls. Take all precautions to ensure that hot air exhausted from the engine and driven machine cooling systems cannot be recirculated. If such hot air is taken in by the engine or driven machine cooling fan, this may cause overheating of the unit; if taken in for combustion, the engine power will be reduced.
- 12 Generators shall be stalled on an even, solid floor, in a clean location with sufficient ventilation. If the floor is not level or can vary in inclination, consult Chicago Pneumatic.
- 13 The electrical connections shall correspond to local codes. The machines shall be earthed and protected against short circuits by fuses or circuit breakers.
- 14 Never connect the generator outlets to an installation which is also connected to a public mains.
- 15 Before connecting a load, switch off the corresponding circuit breaker, and check whether frequency, voltage, current and power factor comply with the ratings of the generator.

0.4 SAFETY DURING USE AND OPERATION

- 1 When the unit has to operate in a fire-hazardous environment, each engine exhaust has to be provided with a spark arrestor to trap incendiary sparks.
- 2 The exhaust contains carbon monoxide which is a lethal gas. When the unit is used in a confined space, conduct the engine exhaust to the outside atmosphere by a pipe of sufficient diameter; do this in such a way that no extra back pressure is created for the engine. If necessary, install an extractor. Observe any existing local regulations. Make sure that the unit has sufficient air intake for operation. If necessary, install extra air intake ducts.
- 3 When operating in a dust-laden atmosphere, place the unit so that dust is not carried towards it by the wind. Operation in clean surroundings considerably extends the intervals for cleaning the air intake filters and the cores of the coolers.
- 4 Never remove a filler cap of the cooling water system of a hot engine. Wait until the engine has sufficiently cooled down.
- 5 Never refill fuel while the unit is running, unless otherwise stated in the Chicago Pneumatic Instruction Book (AIB). Keep fuel away from hot parts such as air outlet pipes or the engine exhaust. Do not smoke when fuelling. When fuelling from an automatic pump, an earthing cable should be connected to the unit to discharge static electricity. Never spill nor leave oil, fuel, coolant or cleansing agent in or around the unit.
- 6 All doors shall be shut during operation so as not to disturb the cooling air flow inside the bodywork and/or render the silencing less effective. A door should be kept open for a short period only e.g. for inspection or adjustment.
- 7 Periodically carry out maintenance works according to the maintenance schedule.
- 8 Stationary housing guards are provided on all rotating or reciprocating parts not otherwise protected and which may be hazardous to personnel. Machinery shall never be put into operation, when such guards have been removed, before the guards are securely reinstalled.
- 9 Noise, even at reasonable levels, can cause irritation and disturbance which, over a long period of time, may cause severe injuries to the nervous system of human beings.
When the sound pressure level, at any point where

- personnel normally has to attend, is:
below 70 dB(A):no action needs to be taken,
above 70 dB(A):noise-protective devices should be provided for people continuously being present in the room,
below 85 dB(A):no action needs to be taken for occasional visitors staying a limited time only,
above 85 dB(A):room to be classified as a noise-hazardous area and an obvious warning shall be placed permanently at each entrance to alert people entering the room, for even relatively short times, about the need to wear ear protectors,
above 95 dB(A):the warning(s) at the entrance(s) shall be completed with the recommendation that also occasional visitors shall wear ear protectors,
above 105 dB(A):special ear protectors that are adequate for this noise level and the spectral composition of the noise shall be provided and a special warning to that effect shall be placed at each entrance.
- 10 Insulation or safety guards of parts the temperature of which can be in excess of 80 °C (175 °F) and which may be accidentally touched by personnel shall not be removed before the parts have cooled to room temperature.
 - 11 Never operate the unit in surroundings where there is a possibility of taking in flammable or toxic fumes.
 - 12 If the working process produces fumes, dust or vibration hazards, etc., take the necessary steps to eliminate the risk of personnel injury.
 - 13 When using compressed air or inert gas to clean down equipment, do so with caution and use the appropriate protection, at least safety glasses, for the operator as well as for any bystander. Do not apply compressed air or inert gas to your skin or direct an air or gas stream at people. Never use it to clean dirt from your clothes.
 - 14 When washing parts in or with a cleaning solvent, provide the required ventilation and use appropriate protection such as a breathing filter, safety glasses, rubber apron and gloves, etc.
 - 15 Safety shoes should be compulsory in any workshop and if there is a risk, however small, of falling objects, wearing of a safety helmet should be included.
 - 16 If there is a risk of inhaling hazardous gases, fumes or dust, the respiratory organs must be protected and depending on the nature of the hazard, so must the eyes and skin.
 - 17 Remember that where there is visible dust, the finer,

- invisible particles will almost certainly be present too; but the fact that no dust can be seen is not a reliable indication that dangerous, invisible dust is not present in the air.
- 18 Never operate the generator in excess of its limits as indicated in the technical specifications and avoid long no-load sequences.
 - 19 Never operate the generator in a humid atmosphere. Excessive moisture causes worsening of the generator insulation.
 - 20 Do not open electrical cabinets, cubicles or other equipment while voltage is supplied. If such cannot be avoided, e.g. for measurements, tests or adjustments, have the action carried out by a qualified electrician only, with appropriate tools, and ascertain that the required bodily protection against electrical hazards is applied.
 - 21 Never touch the power terminals during operation of the machine.
 - 22 Whenever an abnormal condition arises, e.g. excessive vibration, noise, odour, etc., switch the circuit breakers to OFF and stop the engine. Correct the faulty condition before restarting.
 - 23 Check the electric cables regularly. Damaged cables and insufficient lightening of connections may cause electric shocks. Whenever damaged wires or dangerous conditions are observed, switch the circuit breakers to OFF and stop the engine. Replace the damaged wires or correct the dangerous condition before restarting. Make sure that all electric connections are securely tightened.
 - 24 Avoid overloading the generator. The generator is provided with circuit breakers for overload protection. When a breaker has tripped, reduce the concerned load before restarting.
 - 25 If the generator is used as stand-by for the mains supply, it must not be operated without control system which automatically disconnects the generator from the mains when the mains supply is restored.
 - 26 Never remove the cover of the output terminals during operation. Before connecting or disconnecting wires, switch off the load and the circuit breakers, stop the machine and make sure that the machine cannot be started inadvertently or there is any residual voltage on the power circuit.
 - 27 Running the generator at low load for long periods will reduce the lifetime of the engine.

0.5 SAFETY DURING MAINTENANCE AND REPAIR

Maintenance, overhaul and repair work shall only be carried out by adequately trained personnel; if required, under supervision of someone qualified for the job.

- 1 Use only the correct tools for maintenance and repair work, and only tools which are in good condition.
- 2 Parts shall only be replaced by genuine Chicago Pneumatic replacement parts.
- 3 All maintenance work, other than routine attention, shall only be undertaken when the unit is stopped. Steps shall be taken to prevent inadvertent starting. In addition, a warning sign bearing a legend such as "work in progress; do not start" shall be attached to the starting equipment.
On engine-driven units the battery shall be disconnected and removed or the terminals covered by insulating caps.
On electrically driven units the main switch shall be locked in open position and the fuses shall be taken out. A warning sign bearing a legend such as "work in progress; do not supply voltage" shall be attached to the fuse box or main switch.
- 4 Prior to stripping an engine or other machine or undertaking major overhaul on it, prevent all movable parts from rolling over or moving.
- 5 Make sure that no tools, loose parts or rags are left in or on the machine. Never leave rags or loose clothing near the engine air intake.
- 6 Never use flammable solvents for cleaning (fire-risk).
- 7 Take safety precautions against toxic vapours of cleaning liquids.
- 8 Never use machine parts as a climbing aid.
- 9 Observe scrupulous cleanliness during maintenance and repair. Keep away dirt, cover the parts and exposed openings with a clean cloth, paper or tape.
- 10 Never weld on or perform any operation involving heat near the fuel or oil systems. Fuel and oil tanks must be completely purged, e.g. by steam-cleaning, before carrying out such operations. Never weld on, or in any way modify, pressure vessels. Disconnect the alternator cables during arc welding on the unit.
- 11 Support the towbar and the axle(s) securely if working underneath the unit or when removing a wheel. Do not

rely on jacks.

- 12 Do not remove any of, or tamper with, the sound-damping material. Keep the material free of dirt and liquids such as fuel, oil and cleansing agents. If any sound-damping material is damaged, replace it to prevent the sound pressure level from increasing.
- 13 Use only lubricating oils and greases recommended or approved by Chicago Pneumatic or the machine manufacturer. Ascertain that the selected lubricants comply with all applicable safety regulations, especially with regard to explosion or fire-risk and the possibility of decomposition or generation of hazardous gases. Never mix synthetic with mineral oil.
- 14 Protect the engine, alternator, air intake filter, electrical and regulating components, etc., to prevent moisture ingress, e.g. when steam-cleaning.
- 15 When performing any operation involving heat, flames or sparks on a machine, the surrounding components shall first be screened with non-flammable material.
- 16 Never use a light source with open flame for inspecting the interior of a machine.
- 17 When repair has been completed, the machine shall be barred over at least one revolution for reciprocating machines, several revolutions for rotary ones to ensure that there is no mechanical interference within the machine or driver. Check the direction of rotation of electric motors when starting up the machine initially and after any alteration to the electrical connection(s) or switch gear, to check that the oil pump and the fan function properly.
- 18 Maintenance and repair work should be recorded in an operator's logbook for all machinery. Frequency and nature of repairs can reveal unsafe conditions.
- 19 When hot parts have to be handled, e.g. shrink fitting, special heat-resistant gloves shall be used and, if required, other body protection shall be applied.
- 20 When using cartridge type breathing filter equipment, ascertain that the correct type of cartridge is used and that its useful service life is not surpassed.
- 21 Make sure that oil, solvents and other substances likely to pollute the environment are properly disposed of.
- 22 Before clearing the generator for use after maintenance or overhaul, submit it to a testrun, check that the AC power performance is correct and that the control and shutdown devices function correctly.

0.6 TOOL APPLICATIONS SAFETY

Apply the proper tool for each job. With the knowledge of correct tool use and knowing the limitations of tools, along with some common sense, many accidents can be prevented.

Special service tools are available for specific jobs and should be used when recommended. The use of these tools will save time and prevent damage to parts.

0.7 SPECIFIC SAFETY PRECAUTIONS

Batteries

When servicing batteries, always wear protecting clothing and glasses.

- 1 The electrolyte in batteries is a sulphuric acid solution which is fatal if it hits your eyes, and which can cause burns if it contacts your skin. Therefore, be careful when handling batteries, e.g. when checking the charge condition.
- 2 Install a sign prohibiting fire, open flame and smoking at the post where batteries are being charged.
- 3 When batteries are being charged, an explosive gas mixture forms in the cells and might escape through the vent holes in the plugs.
Thus an explosive atmosphere may form around the battery if ventilation is poor, and can remain in and around the battery for several hours after it has been charged. Therefore:
 - never smoke near batteries being, or having recently been, charged,
 - never break live circuits at battery terminals, because a spark usually occurs.
- 4 When connecting an auxiliary battery (AB) in parallel to the unit battery (CB) with booster cables: connect the + pole of AB to the + pole of CB, then connect the - pole of CB to the mass of the unit. Disconnect in the reverse order.

SERVICE PAK

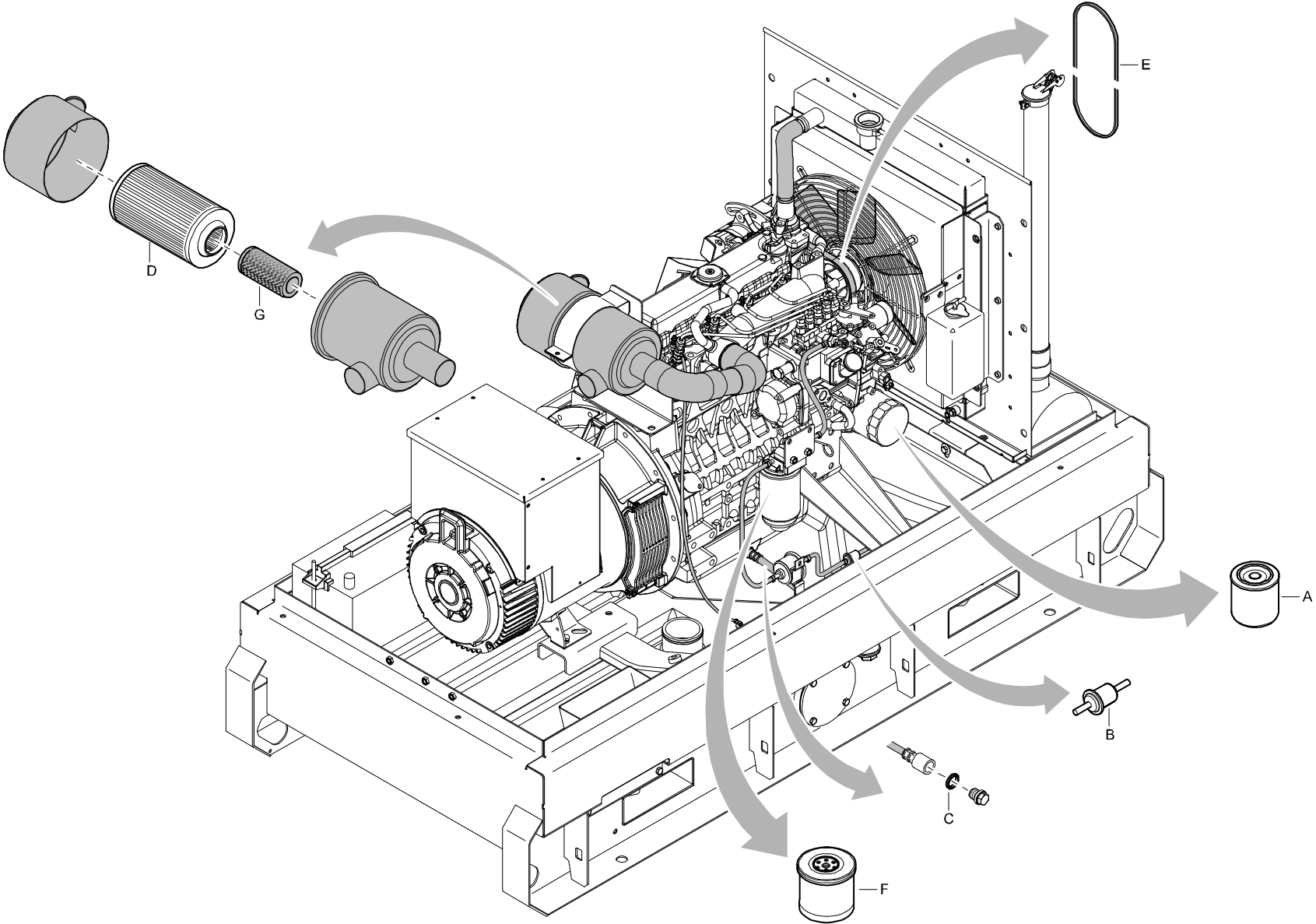

SERVICE PAK

REF	PART NUMBER	DESIGNATION	QTY	REF	PART NUMBER	DESIGNATION	QTY	REF	PART NUMBER	DESIGNATION	QTY
-	1310 3004 22	SERVICE PAK 500 HR									
•A	-	OIL FILTER	1								
•B	-	FUEL PREFILTER	1								
•C	-	GASKET	1								
•D	-	AIR FILTER	1								
•E	-	V-BELT	1								
•F	-	FUEL FILTER	1								
-	1310 3004 23	SERVICE PAK 1000 HR									
•A	-	OIL FILTER	1								
•B	-	FUEL PREFILTER	1								
•C	-	GASKET	1								
•D	-	AIR FILTER	1								
•E	-	V-BELT	1								
•F	-	FUEL FILTER	1								
•G	-	SAFETY CARTRIDGE	1								

ENGINE COOLANT - GENCOOL EG

REF	PART NUMBER	DESIGNATION	QTY
A	1626 2255 00	GENCOOL EG (5 LITER)	1
B	1626 2257 00	GENCOOL EG (5 LITER) CONCENTRATE	1
C	1626 2256 00	GENCOOL EG (20 LITER)	1

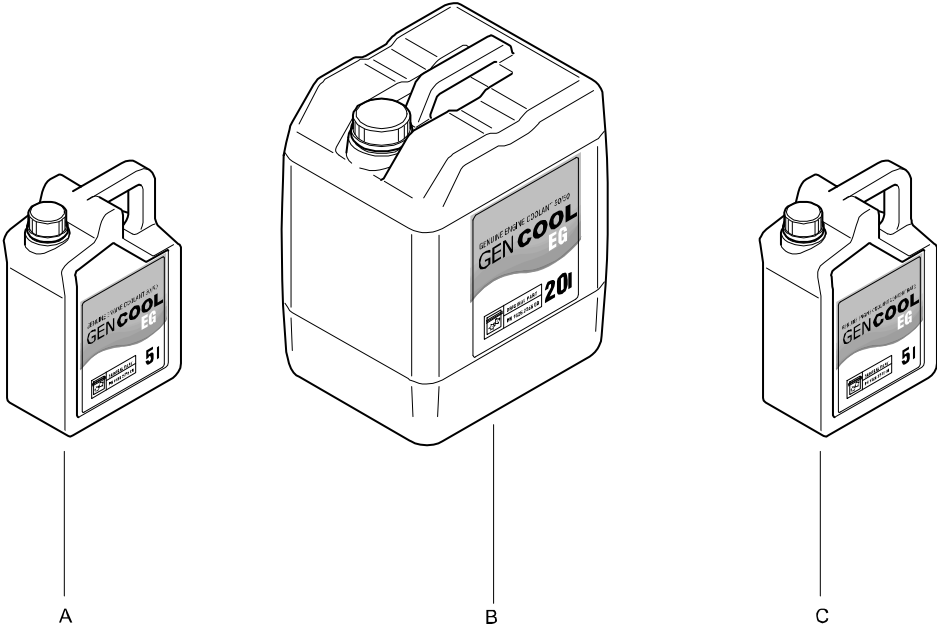

ENGINE OIL - GENOIL 15W40

REF	PART NUMBER	DESIGNATION	QTY
A	1626 2262 00	GENOIL 15W 40 (5 LITER)	1
B	1626 2263 00	GENOIL 15W 40 (20 LITER)	1

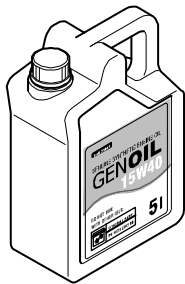

A



B

AIR INLET - STANDARD

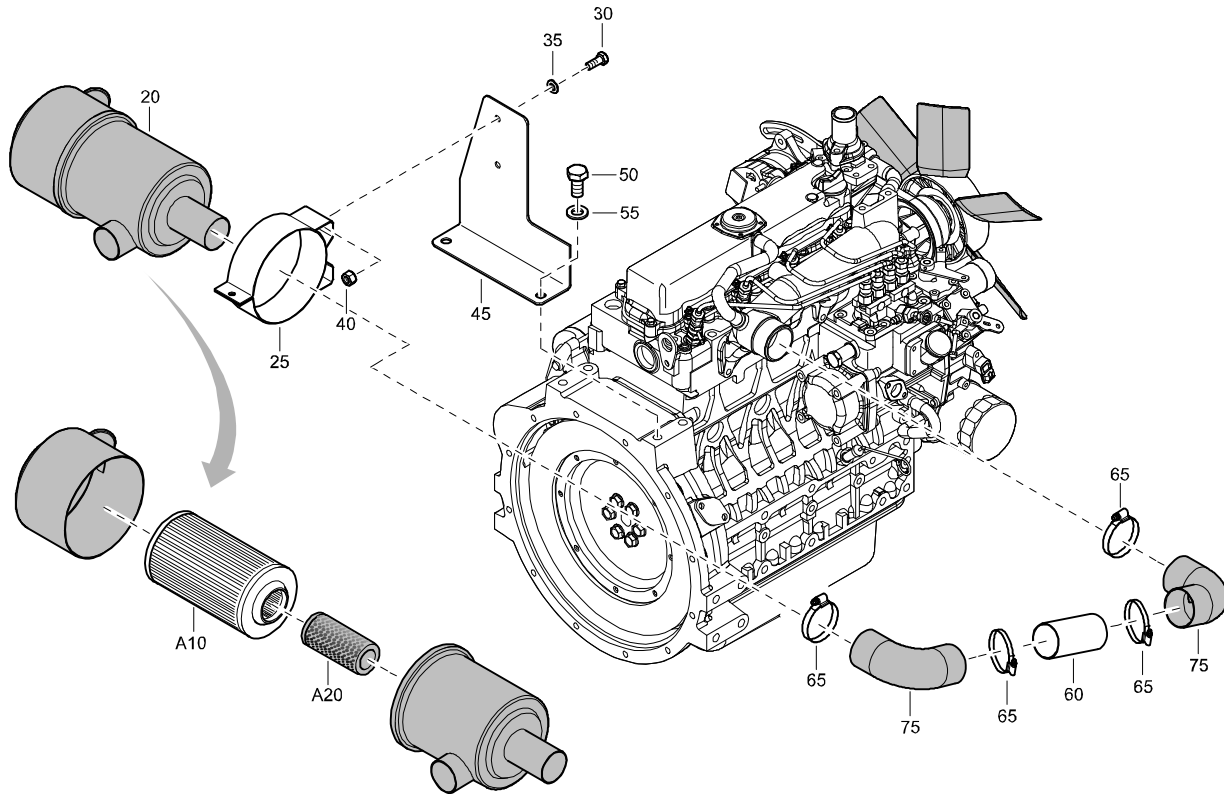

REF	PART NUMBER	DESIGNATION	QTY
20	1310 4853 00	AIR FILTER	1
A10	2914 9302 00	ELEMENT	1
A20	2914 9303 00	SAFETY CARTRIDGE	1
25	1310 0720 79	BRACKET AIR FILTER	1
30	0147 1323 03	HEX HEAD SCREW	2
35	0301 2335 00	PLAIN WASHER	2
40	0266 2110 00	HEX.NUT	2
45	1310 4860 00	SUPPORT AIR INLET	1
50	0144 3360 00	SCREW	2
55	0301 2358 00	FLAT WASHER	2
60	1310 0720 78	TUBE AIR INLET	1
65	0347 6114 00	CLAMP-HOSE	4
75	1310 0304 85	RUBBER ELBOW	2

ENGINE AND ACCESSORIES - STANDARD

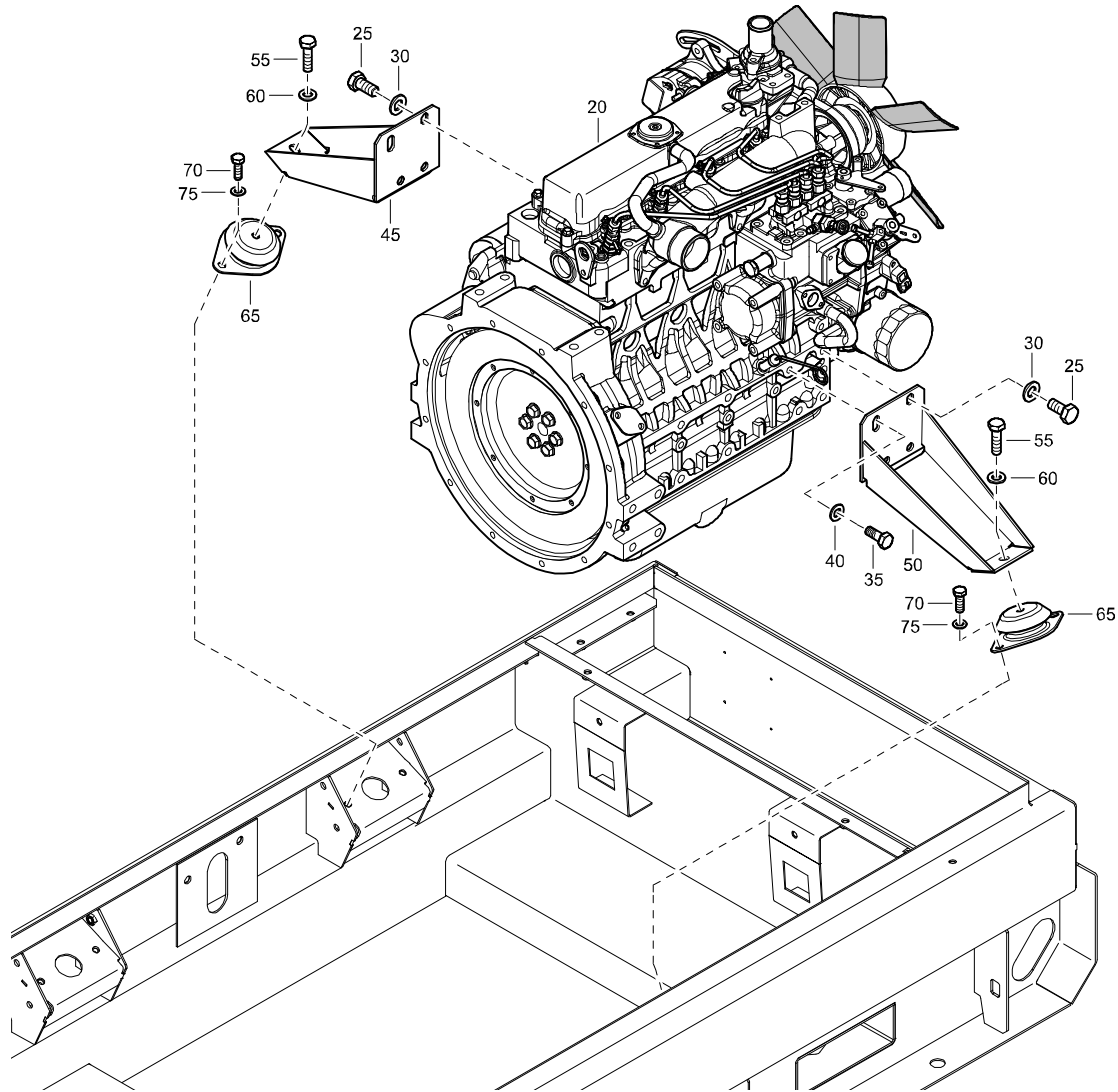

REF	PART NUMBER	DESIGNATION	QTY
20	1310 4837 00	ENGINE	1
25	0147 1959 50	HEX HEAD SCREW	6
30	0301 2358 00	FLAT WASHER	6
35	0147 1959 42	HEX HEAD SCREW	2
40	0301 2344 00	FLAT WASHER	2
45	1310 4850 01	FOOT ENGINE RIGHT	1
50	1310 4851 01	FOOT ENGINE LEFT	1
55	0147 1363 15	HEX HEAD SCREW	2
60	0301 2344 00	FLAT WASHER	2
65	1615 4945 02	VIBRATION MOUNT	2
70	0147 1323 15	HEX HEAD SCREW	4
75	0301 2335 00	FLAT WASHER	4

COOLING SYSTEM - STANDARD

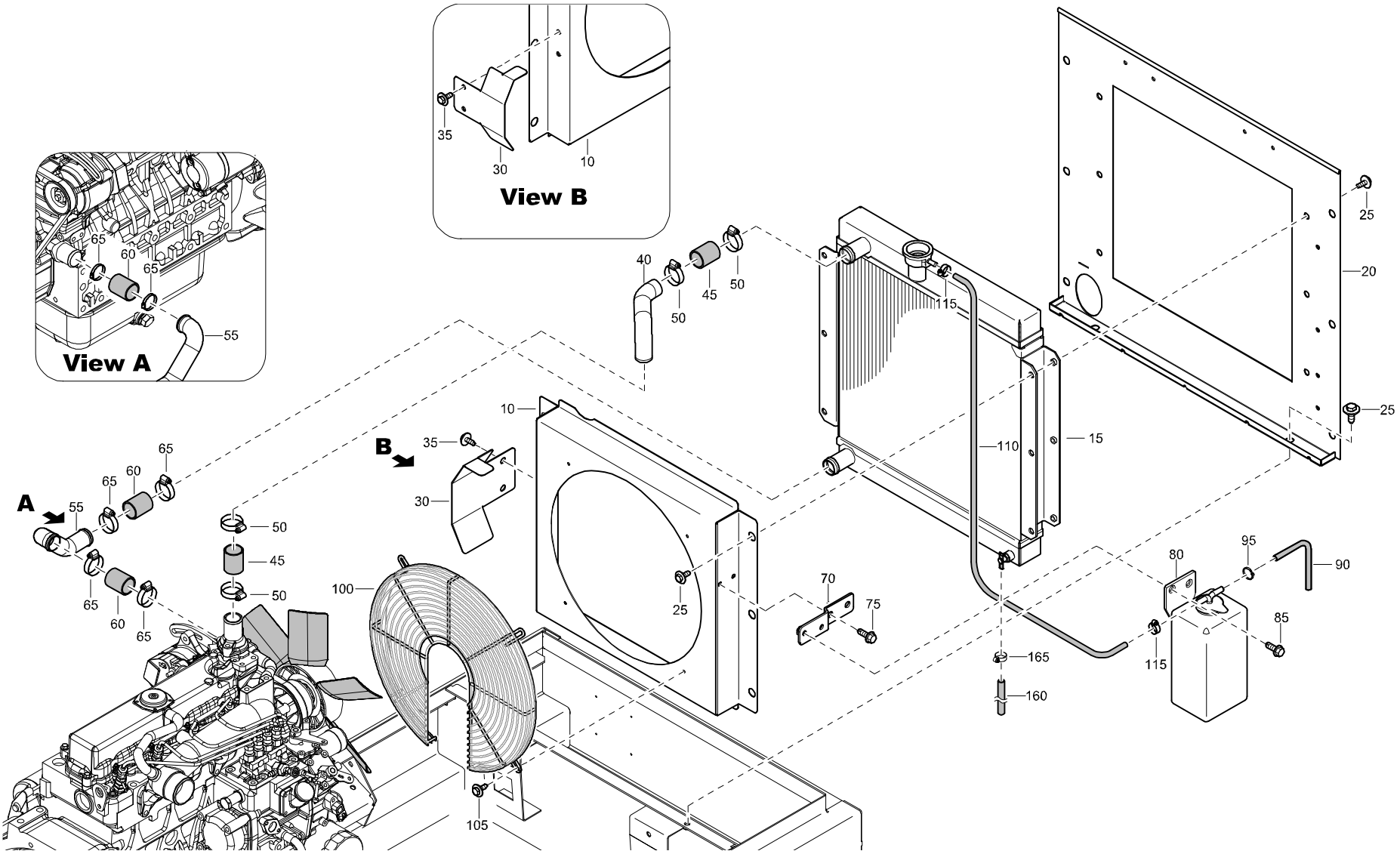

COOLING SYSTEM - STANDARD

REF	PART NUMBER	DESIGNATION	QTY	REF	PART NUMBER	DESIGNATION	QTY	REF	PART NUMBER	DESIGNATION	QTY
10	1310 4859 30	FAN BOX	1								
15	1310 4805 00	COOLER	1								
20	1310 4806 00	PLATE	1								
25	1615 5664 00	HEX. HEAD SCREW	14								
30	1310 4866 00	BRACKET	1								
35	1615 5664 00	HEX. HEAD SCREW	2								
40	1310 6000 59	PIPE UPPER RADIATOR	1								
45	1310 6000 73	HUMP HOSE	2								
50	0347 6113 00	HOSE CLAMP	4								
55	1310 6000 51	PIPE LOWER RADIATOR	1								
60	1310 6000 73	HUMP HOSE	2								
65	0347 6113 00	HOSE CLAMP	4								
70	1310 4865 00	BRACKET	1								
75	1619 2766 00	HEX. HEAD SCREW	2								
80	1310 6000 72	COOLANT RECOVERY BOTTLE	1								
85	1619 2766 00	HEX. HEAD SCREW	2								
90	0099 9910 28	PLASTIC TUBE	AR								
95	0348 0101 17	CABLE TIE	1								
100	1310 0720 82	GUARD	1								
105	1615 5664 00	HEX. HEAD SCREW	4								
110	0075 4005 55	FUEL HOSE	AR								
115	0347 6103 00	HOSE CLAMP	2								
160	1310 0355 56	TUBE	3								
165	1310 0323 84	HOSE CLAMP	1								

ALTERNATOR AND ACCESSORIES - STANDARD

AVR - R220 - 2914844400

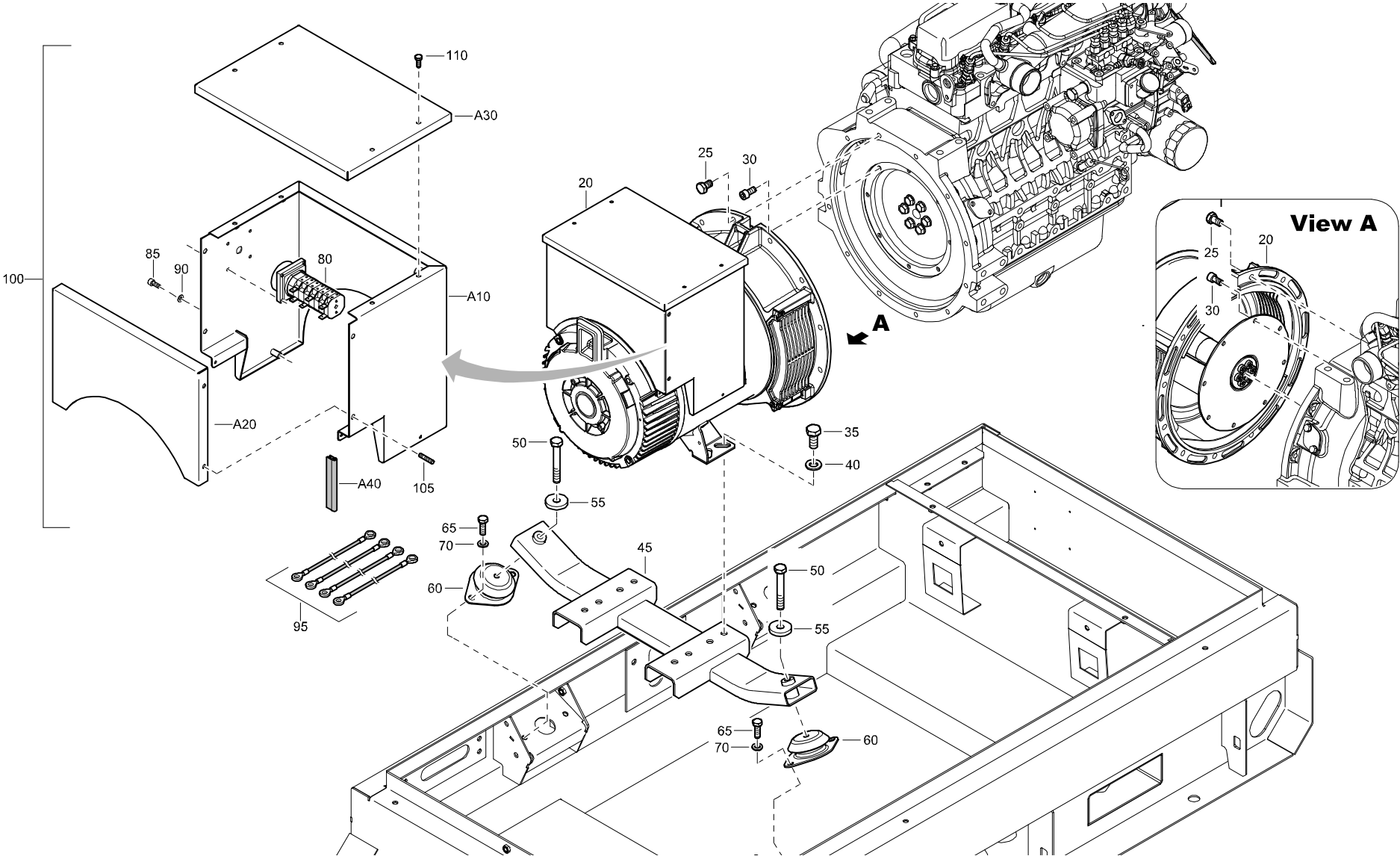

ALTERNATOR AND ACCESSORIES - STANDARD

REF	PART NUMBER	DESIGNATION	QTY	REF	PART NUMBER	DESIGNATION	QTY	REF	PART NUMBER	DESIGNATION	QTY
20	1310 6066 05	ALTERNATOR W/O PMG	1								
25	0144 3287 03	HEX HEAD SCREW	8								
30	0211 5162 03	SCREW	8								
35	0147 1398 03	HEX HEAD SCREW	2								
40	0301 2358 00	PLAIN WASHER	2								
45	1626 3881 03	SUPPORT	1								
50	0147 1107 39	HEX HEAD SCREW	2								
55	1503 0205 00	PLAIN WASHER	2								
60	1615 4945 02	VIBRATION MOUNT	2								
65	0147 1323 15	HEX HEAD SCREW	4								
70	0301 2335 00	FLAT WASHER	4								
80	1089 9378 24	SWITCH SELECTOR	1								
85	0211 1957 42	SOC HEAD CAP SCREW	4								
90	0301 2318 00	FLAT WASHER	4								
95	1310 4949 00	WIRE SET	1								
100	1310 6080 80	ALTERNATOR HOUSING	1								
A10	1310 6080 00	PLATE ALT FRONT HOUSING	1								
A20	1310 6079 00	PLATE REAR ALT HOUSING	1								
A30	1310 6078 00	PLATE TOP ALT HOUSING	1								
A40	1202 6584 00	SEAL-EDGE	AR								
105	1310 2500 63	INSERT-THD	8								
110	1310 0308 82	HEX HEAD SCREW	8								

BODYWORK - STANDARD

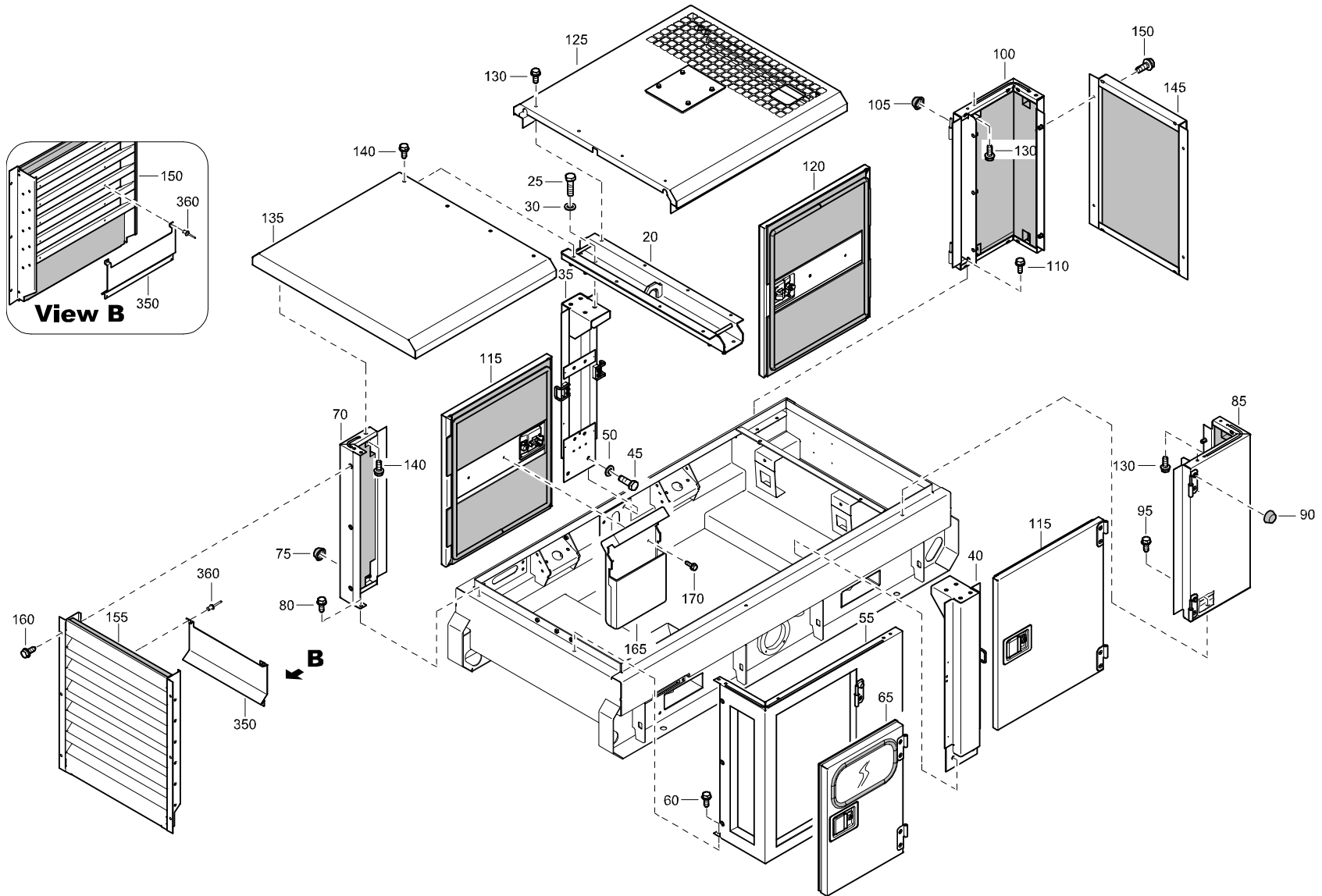

BODYWORK - STANDARD

REF	PART NUMBER	DESIGNATION	QTY	REF	PART NUMBER	DESIGNATION	QTY	REF	PART NUMBER	DESIGNATION	QTY
20	1310 4827 00	BEAM	1	165	1310 0356 39	HOLDER (DOCUMENT)	1				
25	0147 1363 15	HEX. HEAD SCREW	8	170	1619 5898 01	HEX. HEAD SCREW	4				
30	0301 2344 00	PLAIN WASHER	8	350	1310 4846 00	SUPPORT	1				
35	1310 4828 80	LIFTING VERT BEAM ASSY (For details see page 41)	1	360	0129 3116 00	BLIND RIVET	4				
40	1310 4828 90	LIFTING VERT BEAM ASSY (For details see page 42)	1								
45	0147 1958 74	HEX. HEAD SCREW	4								
50	0301 2344 00	PLAIN WASHER	4								
55	1310 4829 80	CORNER CUBICLE ASSY (For details see page 40)	1								
60	1619 2766 00	HEX. HEAD SCREW	2								
65	1310 4831 80	DOOR CUBICLE ASSY (For details see page 43)	1								
70	1310 4833 80	CORNER ASSY (For details see page 44)	1								
75	1613 3672 00	CAP	2								
80	1619 2766 00	HEX. HEAD SCREW	2								
85	1310 4834 80	CORNER FRONT GREY ASSY (For details see page 45)	1								
90	1613 3672 00	CAP	2								
95	1619 2766 00	HEX. HEAD SCREW	2								
100	1310 4835 80	CORNER FRONT GREY ASSY (For details see page 46)	1								
105	1613 3672 00	CAP	2								
110	1619 2766 00	HEX. HEAD SCREW	2								
115	1310 4836 80	DOOR ASSY (For details see page 47)	2								
120	1310 4837 80	DOOR ASSY (For details see page 48)	1								
125	1310 4838 80	ROOF ASSY FRONT (For details see page 49)	1								
130	1619 2766 00	HEX. HEAD SCREW	8								
135	1310 4842 80	ROOF ASSY REAR (For details see page 50)	1								
140	1619 2766 00	HEX. HEAD SCREW	8								
145	1310 4844 80	PANEL SERVICE ASSY (For details see page 51)	1								
150	1619 2766 00	HEX. HEAD SCREW	4								
155	1310 4845 80	BAFFLE ASSY AIR INLET (For details see page 52)	1								
160	1619 2766 00	HEX. HEAD SCREW	4								

ELECTRICAL SYSTEM - WITHOUT BATTERY SWITCH - STANDARD

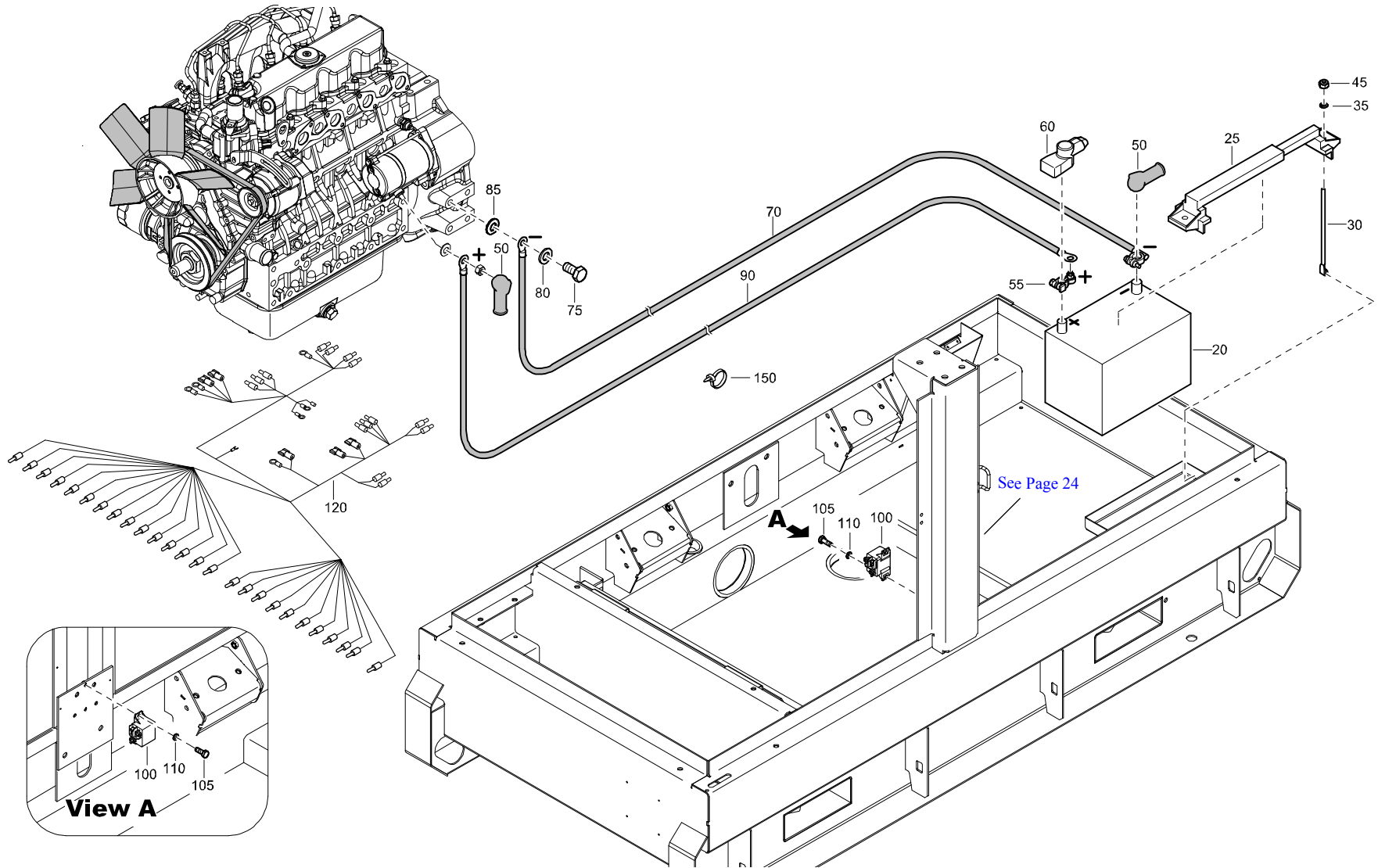

ELECTRICAL SYSTEM - WITHOUT BATTERY SWITCH - STANDARD

REF	PART NUMBER	DESIGNATION	QTY	REF	PART NUMBER	DESIGNATION	QTY	REF	PART NUMBER	DESIGNATION	QTY
20	1310 6000 17	BATTERY	1								
25	1310 6000 53	BRACKET BATTERY HOLDER	1								
30	1310 0311 67	BOLT-J	2								
35	0333 2225 00	SPRING WASHER	2								
45	0291 1108 00	LOCKNUT	2								
50	1310 0363 91	INSULATOR TERMINAL	2								
55	1604 5043 00	CLAMP	1								
60	1604 7216 00	COVER RED BATTERY CONNECTOR	1								
70	1310 0333 25	BATTERY CABLE	1								
75	0147 1400 03	HEX HEAD SCREW	1								
80	0301 2358 00	FLAT WASHER	1								
85	1088 0019 03	CONTACT WASHER	1								
90	1310 4098 00	BATTERY CABLE	1								
100	1310 0304 71	RELAY	1								
105	0147 1246 03	HEX HEAD SCREW	2								
110	0301 2321 00	FLAT WASHER	2								
120	1626 1791 03	WIRE HARNESS	1								
150	1088 1301 02	CABLE TY	10								

DRAINS - STANDARD

REF	PART NUMBER	DESIGNATION	QTY
10	1310 0353 82	HOSE ASY ENGINE OIL DRAIN	1
20	VAL02131	BALL VALVE	1
30	0603 0118 14	NIPPLE	1
40	0663 3122 00	O-RING	1
50	1310 0354 87	ADAPTER	1
60	1310 0355 25	HEX PLUG	1

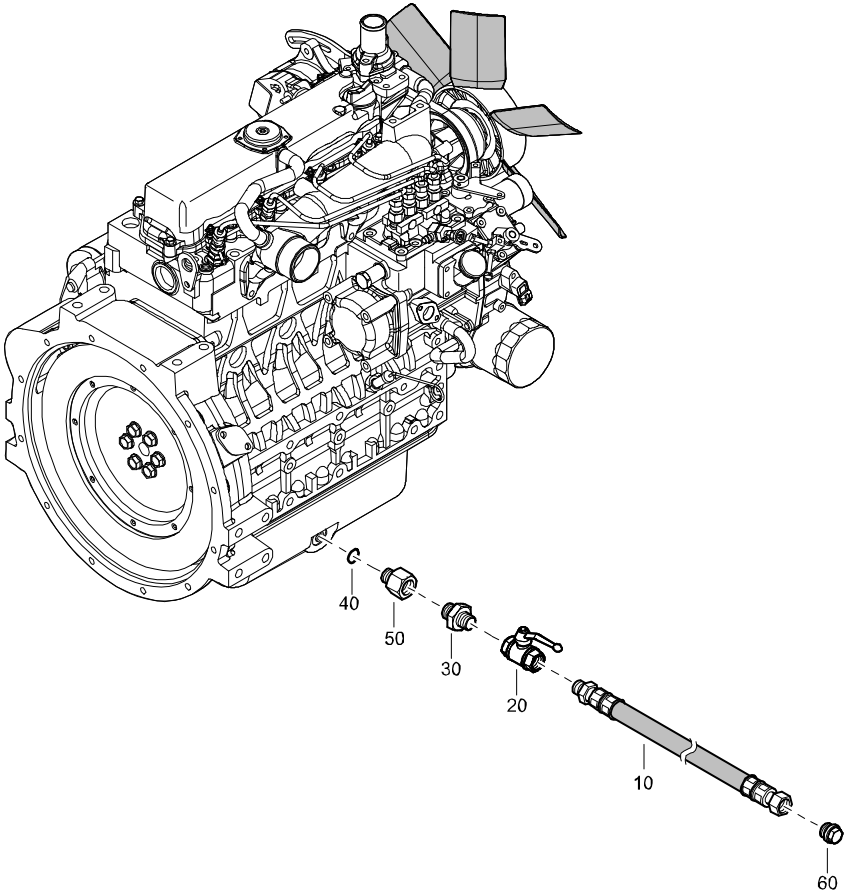

EXHAUST SYSTEM - STANDARD

REF	PART NUMBER	DESIGNATION	QTY
20	1310 4811 00	EXHAUST MUFFLER	1
30	1615 5664 00	SCRAPER BOLT	4
35	1626 0927 01	PIPE EXHAUST	1
40	0346 3001 08	CLAMP EXHAUST	1
45	0147 1323 03	HEX HEAD SCREW	4
50	0301 2335 00	FLAT WASHER	4
60	1310 4814 00	PIPE EXHAUST	1
65	1615 7123 00	RAINCAP	1
70	1310 4813 00	SHIELD EXHAUST PIPE	1
75	1619 2766 00	SELF TAP SCREW	1

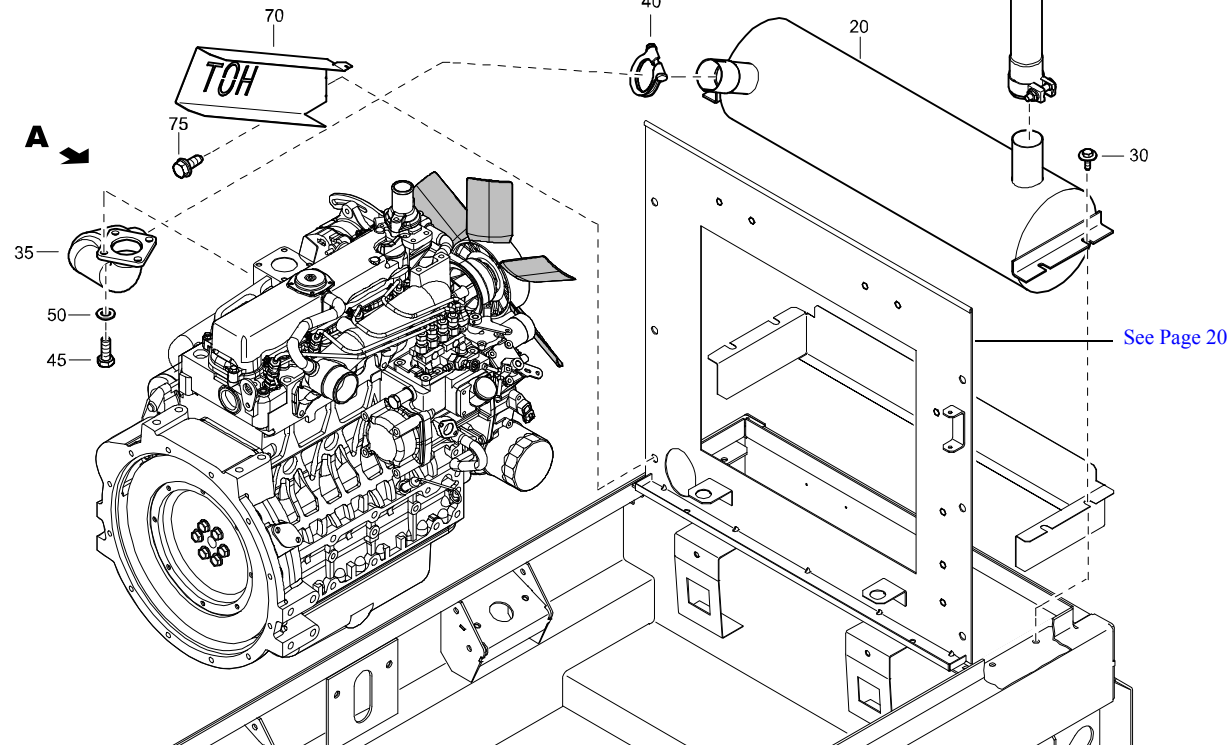
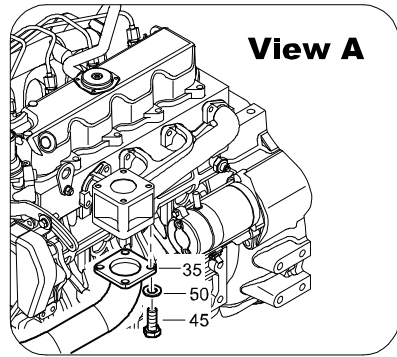

CUBICLE ASSEMBLY - CPG 20 - STANDARD

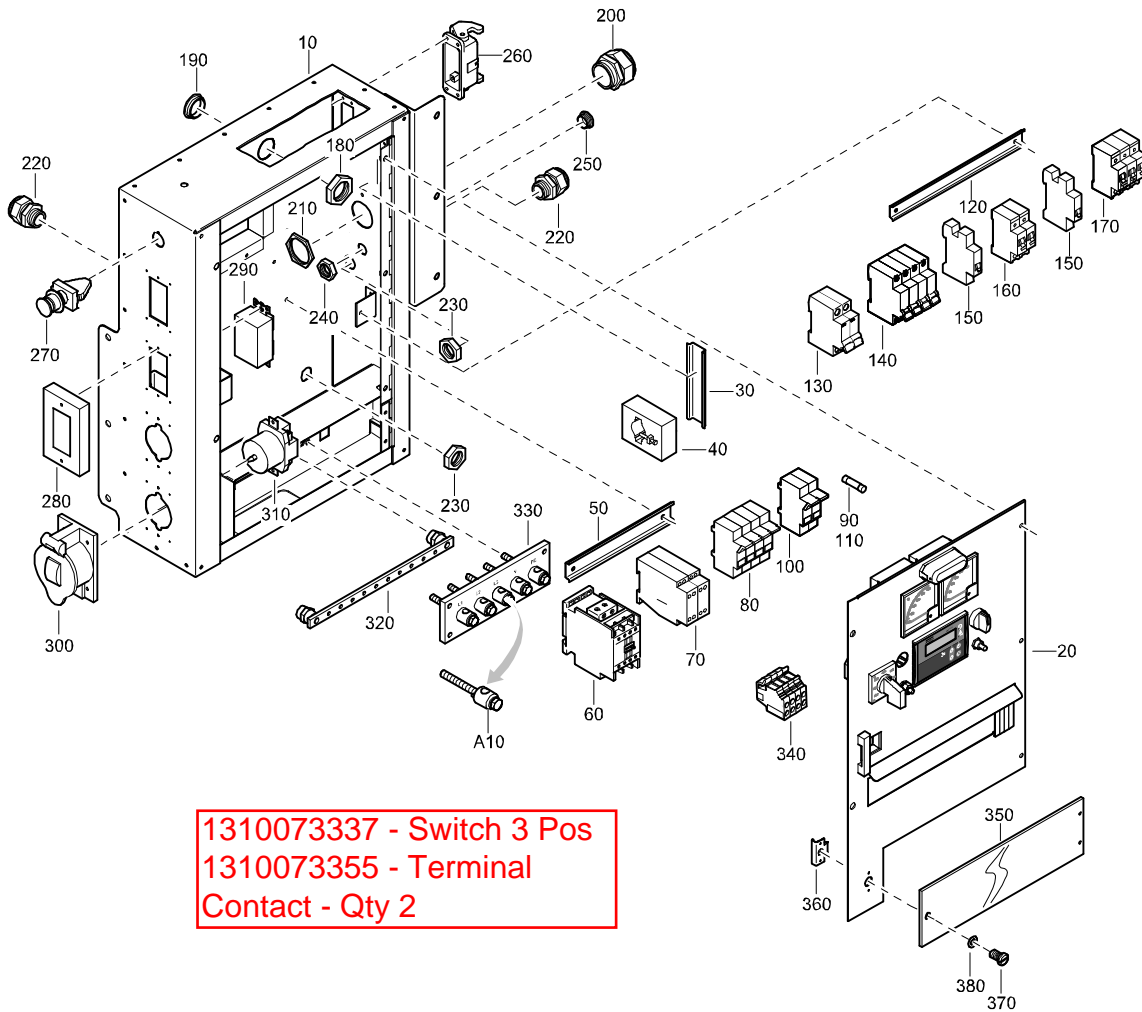

1310073337 - Switch 3 Pos
 1310073355 - Terminal
 Contact - Qty 2

REF	PART NUMBER	DESIGNATION	QTY
10	1310 4900 00	CUBICLE PANEL	1
20	1310 4901 80	CONTROL PANEL ASSY (For details see page 53)	1
30	0090 1400 02	DIN RAIL	AR
40	1310 0307 35	CURRENT TRANSFORMER	1
50	0090 1400 02	DIN RAIL	AR
60	1089 9496 20	CONTACTOR	1
70	1089 9384 01	RELAY	2
80	1089 9333 15	FUSE HOLDER	4
90	1089 9332 01	FUSE	3
100	1089 9333 13	FUSE HOLDER	2
110	1089 9332 01	FUSE	3
120	0090 1400 02	DIN RAIL	AR
130	C20-C60N	CIRCUIT BREAKER	2
140	1089 9472 25	CIRCUIT BREAKER	2
150	1089 9473 13	SHUNT TRIP	2
160	1089 9472 36	CIRCUIT BREAKER	2
170	1089 9472 33	CIRCUIT BREAKER	1
180	0697 9809 23	HEX NUT	1
190	0697 9810 28	PLUG	1
200	0698 5140 75	CABLE GLAND	1
210	0697 9809 24	HEX NUT	1
220	0698 5140 72	CABLE GLAND	2
230	0697 9809 21	HEX NUT	2
240	0697 9809 20	HEX NUT	2
250	0697 9810 44	PLUG	2
260	1088 0029 50	HARTING HOUSING	1
270	1089 9422 01	EMERGENCY STOP	1
280	1089 9412 11	SOCKET	2
290	1089 9412 01	RECEPTACLE	2
300	1089 9412 12	SOCKET	2
310	1089 9412 02	RECEPTACLE	2
320	1604 2282 00	EARTH RAIL ASSY	1
330	1604 6174 00	TERMINAL BOARD	1
A10	1615 7280 00	TERMINAL	5
340	1088 0027 02	TERMINAL	4
350	1626 2414 00	DOOR LEXEN	1
360	1615 6728 00	DOOR PLATE	1
370	1615 7166 00	SCREW	1
380	1615 6727 00	WASHER	1

CUBICLE ASSEMBLY - CPG 25 - STANDARD

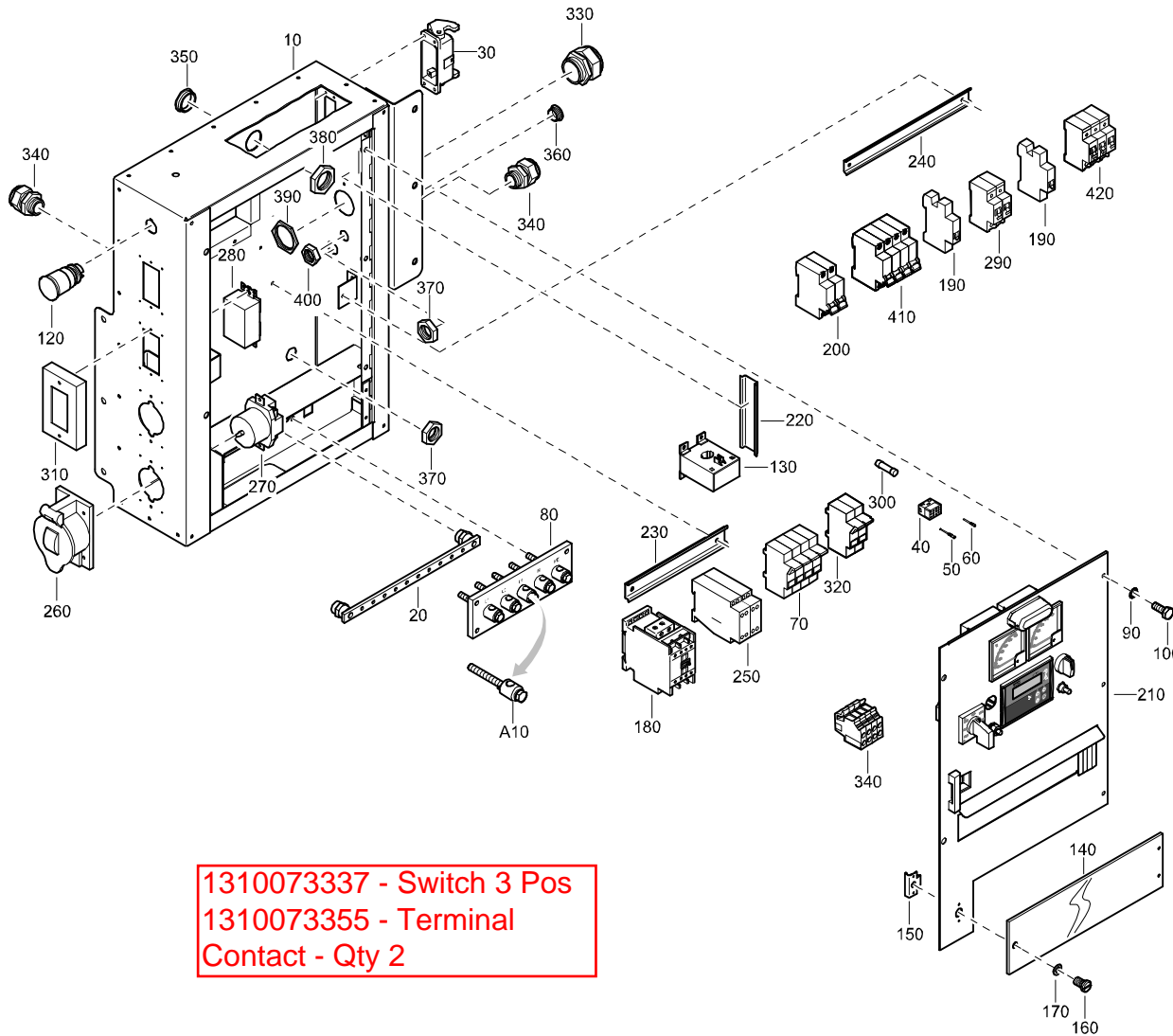

1310073337 - Switch 3 Pos
 1310073355 - Terminal
 Contact - Qty 2

REF	PART NUMBER	DESIGNATION	QTY
10	1310 4900 00	CUBICLE PANEL	1
20	1604 2282 00	EARTH RAIL ASSY	1
30	1088 0029 50	HOUSING	1
40	1088 0029 45	INSERT MALE	1
50	1088 0029 61	CONTACT MALE	1
60	1088 0029 55	CONTACT MALE	1
70	1089 9333 15	FUSEHOLDER	4
80	1604 6174 00	TERMINAL BORAD	1
A10	1615 7280 00	TERMINAL BORAD	1
90	0333 2174 37	LOCK WASHER	5
100	0147 1322 03	HEX HEAD SCREW	5
110	1088 0027 02	TERMINAL	4
120	1089 9622 09	E-STOP	1
130	1089 9357 51	CURRENT TRANSFORMER	1
140	1626 2414 00	DOOR TERMINAL	1
150	1615 6278 00	LATCH DOOR	1
160	1615 7166 00	STUD	1
170	1615 6727 00	WASHER	1
180	1089 9496 20	CONTACTOR	1
190	1089 9473 13	TRIP COIL	2
200	1089 9472 21	CIRCUIT BREAKER	2
210	1310 4901 80	CONTROL PANEL ASSY	1
<i>(For details see page 53)</i>			
220	0090 1400 02	RAIL	1
230	0090 1400 02	RAIL	1
240	0090 1400 02	RAIL	1
250	1089 9384 01	RELAY	2
260	1089 9412 12	PROTECTION	2
270	1089 9412 02	RECEPTACLE	2
280	1089 9412 01	RECEPTACLE	2
290	1089 9472 36	CIRCUIT BREAKER	1
300	1089 9332 01	FUSE	5
310	1089 9412 11	PROTECTION	2
320	1089 9333 13	FUSEHOLDER	2
330	0698 5140 75	CABLE GLAND	1
340	0698 5140 72	CABLE GLAND	2
350	0697 9810 28	PLUG	1
360	0697 9810 44	PLUG	2
370	0697 9809 21	LOCKNUT	2
380	0697 9809 23	LOCKNUT	1
390	0697 9809 24	LOCKNUT	1
400	0697 9809 20	LOCKNUT	2
410	1089 9472 25	CIRCUIT BREAKER	1
420	1089 9472 33	CIRCUIT BREAKER	1

MARKINGS - CPG 20 - STANDARD

30

CPG 20-25

SERVICE PAK

Every 500h / 4 months 1310 3004 92
Every 1000h / Yearly 1310 3004 93

Engine Oil GEN OIL 15W40

51	QUANTITY	1626 2262 00
201	DESCRIPTION	1626 2263 00

Engine Coolant GEN COOL EG

51	QUANTITY	1626 2257 00 (CONCENTRATE)
51	QUANTITY	1626 2258 00
201	DESCRIPTION	1626 2259 00

110

15W 40 OIL

50

WARNING

SEVERE HAZARD!
Machine can start automatically. Disconnect battery prior to servicing. Failure to comply can result in death or serious injury.

140

CAUTION

BURN HAZARD!
Keep clear. Hot exhaust may burn. Failure to comply may result in moderate or minor injury.

60

WARNING

CALIFORNIA PROPOSITION 65 WARNING
Diesel engine exhaust and some of its constituents are known to the State of California to cause cancer, birth defects, and other reproductive harm.

CPG 20

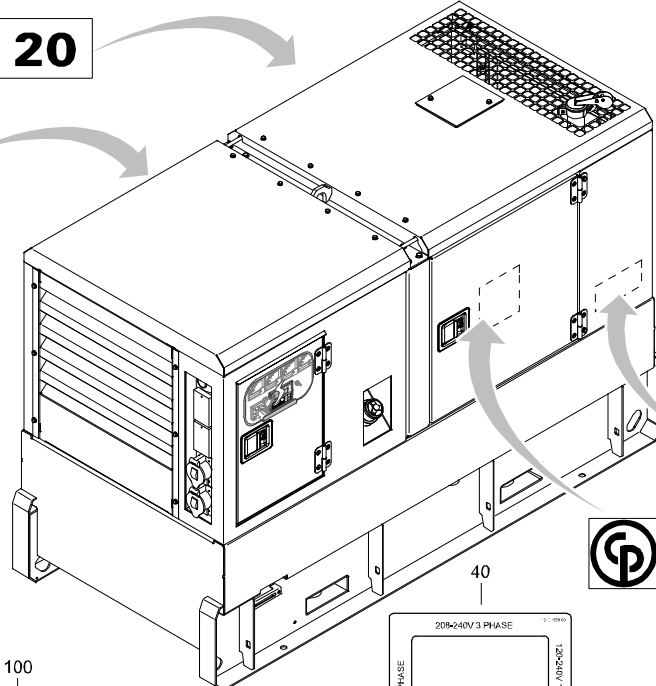

90

WARNING

FIRE HAZARD!
Shut down generator before changing voltage selector switch. Failure to comply could result in death or serious injury.

DANGER HIGH VOLTAGE

CAUTION:
Do not operate selector switch while generator is running. Do not connect to bus panel while generator is running. Do not use L-3 terminal in single phase mode.

SELECTOR SWITCH POSITION	BUS PANEL CONNECTION	CONNECTION VOLTAGE	MAX. AMPS
277/480 3 Phase	L1-N	277 V ac, 1.0PF	31
	L2-N	277 V ac, 1.0PF	31
	L3-N	277 V ac, 1.0PF	31
120/208 3 Phase	L1-N	120 V ac, 1.0PF	70
	L2-N	120 V ac, 1.0PF	70
	L3-N	120 V ac, 1.0PF	70
139/240 3 Phase	L1-L2-L3	208 V ac, 0.8PF	120
	L1-N	139 V ac, 1.0PF	62
	L2-N	139 V ac, 1.0PF	62
120/240	L1-N	120 V ac, 1.0PF	120
	L2-N	120 V ac, 1.0PF	120
	L1-L2	240 V ac, 1.0PF	120

www.cpg.com 180

150

160

Identification of symbols

1. Power on - Local start
2. Remote Start
3. To scroll up through menu
4. To scroll down through menu
5. To enter selection
6. To go back to main menu
7. Warning indication
8. Power ON
9. Remote start Indication

CPG 20

100

CAUTION

Coolant must meet ASTM D6210 OR ASTM D6211. Use of Incorrect coolant will result in damage to the radiator and engine. Refer to the Instruction Manual

120

Relay Function

K 11	High Voltage shunt trip
K 12	Low Voltage shunt trip
K 13	Socket enable contactor

40

208-240V 3 PHASE

480V 3 PHASE

2PH-1NUL, 1ØØP-2ØL

130

NEUTRAL GROUNDED

10

ATTENTION

VOLTAGE SELECTOR POSITION

208-240V 3 PHASE

480V 3 PHASE

2PH-1NUL, 1ØØP-2ØL

70

MARKINGS - CPG 20 - STANDARD

REF	PART NUMBER	DESIGNATION	QTY	REF	PART NUMBER	DESIGNATION	QTY	REF	PART NUMBER	DESIGNATION	QTY
10	1310 4561 00	LABEL SELECTOR SW POSITION	1								
20	1310 4762 00	LABEL QC1002 OPERATING	1								
30	1310 6066 13	LABEL SERVICE PAKS	1								
40	1310 4560 00	LABEL SELECTOR SW VOLTAGES	1								
50	1310 0353 72	LABEL WARNING-UNIT CAN START	2								
60	1310 3112 36	LABEL CALIFORNIA EMISSIONS	1								
70	1310 4946 00	LABEL OPERATING INSTRUCTION	1								
80	1310 4766 00	LABEL HIGH VOLTAGE	1								
90	1310 0356 37	LABEL WARNING ALTERNATOR	1								
100	1310 0356 95	LABEL COOLANT MUST MEET ASTM D	1								
110	1310 0356 38	LABEL OIL FILL TYPE,	1								
120	1310 3124 68	LABEL RELAY FUNCTION	1								
130	1310 3124 67	LABEL NEUTRAL GROUNDED	1								
140	1310 0313 24	LABEL CAUTION HOT EXHAUST	1								
150	-	DATA PLATE (Not available separately)	1								
160	1310 0361 69	RIVET	4								
170	1310 6002 07	MODEL DESIGNATION	2								
180	1310 0720 95	LABEL CP INTERNET	2								
190	1310 4474 00	LABEL CP LOGO	3								

MARKINGS - CPG 25 - STANDARD

30

CPG 20-25			
SERVICE PAK			
Every 500h / 6 months	1310 3004 22		
Every 1000h / 1 year	1310 3004 23		
Engine Oil GEN OIL 15W40			
5 l / 1.3 US gal	1626 2262 00		
20 l / 5.3 US gal	1626 2263 00		
Engine Coolant GEN COOL EG			
5 l / 1.3 US gal	1626 2257 00 (CONCENTRATE)		
5 l / 1.3 US gal	1626 2258 00		
20 l / 5.3 US gal	1626 2259 00		

110
15W 40 OIL
1310 050 18

170
CPG 25

WARNING

FIRE HAZARD!
Shut down generator before changing voltage selector switch. Failure to comply could result in death or serious injury.

1310 0356 17

DANGER
HIGH VOLTAGE

CAUTION:
Do not operate selector switch while generator is running.
Do not connect to bus panel while generator is running.
Do not use L-3 terminal in single phase mode.

1310 4768 00

SELECTOR SWITCH POSITION	BUS PANEL CONNECTION	CONNECTION VOLTAGE	MAX. AMPERE
277/480 3 Phase	L1-N	277 Vac 1.0PF	31
	L2-N	277 Vac 1.0PF	31
	L1-L2-L3	480 Vac 0.8PF	54
120/208 3 Phase	L1-N	120 Vac 1.0PF	70
	L2-N	120 Vac 1.0PF	70
	L1-L2-L3	208 Vac 0.8PF	120
139/240 3 Phase	L1-N	139 Vac 1.0PF	62
	L2-N	139 Vac 1.0PF	62
	L1-L2-L3	240 Vac 0.8PF	108
120/240 1 Ph L1-L2	L1-N	120 Vac 1.0PF	120
	L1-L2	240 Vac 1.0PF	120

www.cp.com —180

WARNING

SEVERE HAZARD!
Machine can start automatically.
Disconnect battery prior to servicing.
Failure to comply can result in death or serious injury.

1310 0355 72

CAUTION

BURN HAZARD!
Keep clear.
Hot exhaust may burn.
Failure to comply may result in moderate or minor injury.

1310 0357 74

60

WARNING

CALIFORNIA PROPOSITION 65 WARNING
Diesel engine exhaust and some of its constituents are known to the State of California to cause cancer, birth defects, and other reproductive harm.

1310 0358 76

100

CAUTION

Coolant must meet ASTM D6210 OR ASTM D6211.
Use of incorrect coolant will result in damage to the radiator and engine.
Refer to the Instruction Manual

1310 0359 66

120

Relay	Function
K 11	High Voltage shunt trip
K 12	Low Voltage shunt trip
K 13	Socket enable contactor

1310 3124 08

130
NEUTRAL GROUNDED
1310 0361 00

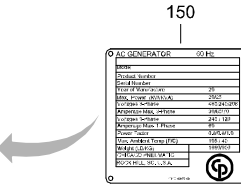

170
CPG 25

10

ATTENTION

VOLTAGE SELECTOR POSITION

208-240V 3 PHASE

480V 3 PHASE

120-240V 1 Ph L1-L2

1310 0362 00

80

Qc1002

Identification of symbols

1. Power on - Local start
2. Remote Start
3. To scroll up through menu
4. To scroll down through menu
5. To enter selection
6. To go back to main menu
7. Warning Indication
8. Power ON
9. Remote start indication

1310 4762 00



MARKINGS - CPG 25 - STANDARD

REF	PART NUMBER	DESIGNATION	QTY	REF	PART NUMBER	DESIGNATION	QTY	REF	PART NUMBER	DESIGNATION	QTY
10	1310 4561 00	LABEL SELECTOR SW POSITION	1								
20	1310 4762 00	LABEL QC1002 OPERATING	1								
30	1310 6066 13	LABEL SERVICE PAKS	1								
40	1310 4560 00	LABEL SELECTOR SW VOLTAGES	1								
50	1310 0353 72	LABEL WARNING-UNIT CAN START	2								
60	1310 3112 36	LABEL CALIFORNIA EMISSIONS	1								
70	1310 4946 00	LABEL OPERATING INSTRUCTION	1								
80	1310 4766 00	LABEL HIGH VOLTAGE	1								
90	1310 0356 37	LABEL WARNING ALTERNATOR	1								
100	1310 0356 95	LABEL COOLANT MUST MEET ASTM D	1								
110	1310 0356 38	LABEL OIL FILL TYPE,	1								
120	1310 3124 68	LABEL RELAY FUNCTION	1								
130	1310 3124 67	LABEL NEUTRAL GROUNDED	1								
140	1310 0313 24	LABEL CAUTION HOT EXHAUST	1								
150	-	DATA PLATE (Not available separately)	1								
160	1310 0361 69	RIVET	4								
170	1310 6066 90	MODEL DESIGNATION	2								
180	1310 0720 95	LABEL CP INTERNET	2								
190	1310 4474 00	LABEL CP LOGO	3								

FRAME AND MOUNTS - STANDARD

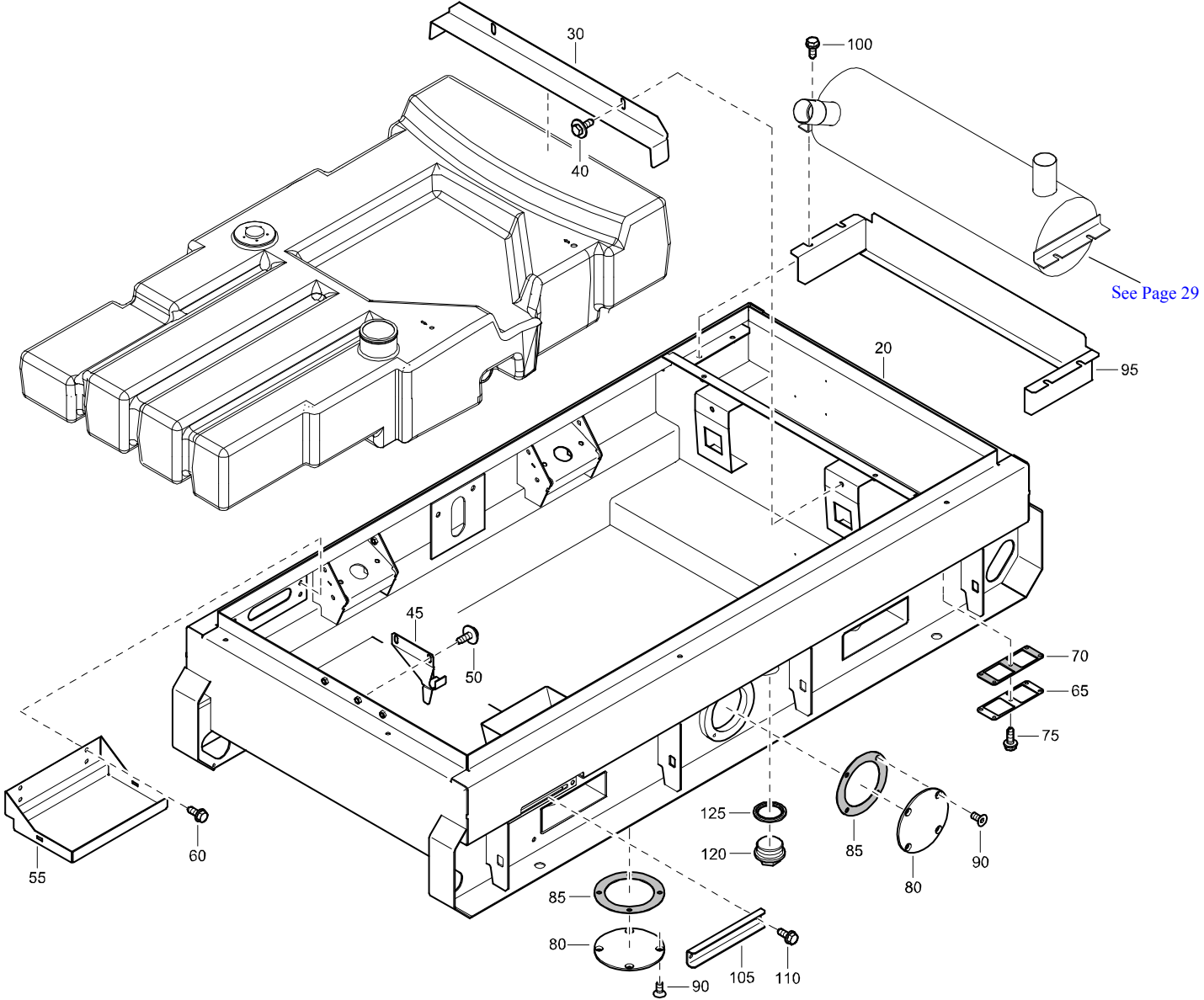

FRAME AND MOUNTS - STANDARD

REF	PART NUMBER	DESIGNATION	QTY	REF	PART NUMBER	DESIGNATION	QTY	REF	PART NUMBER	DESIGNATION	QTY
20	1310 4818 00	FRAME	1								
30	1310 4819 00	BRACKET	1								
40	1615 5664 00	HEX. HEAD SCREW	2								
45	1310 4820 00	BRACKET	1								
50	1615 5664 00	HEX. HEAD SCREW	2								
55	1310 6074 00	SUPPORT	1								
60	1619 2766 00	HEX. HEAD SCREW	4								
65	1310 4604 00	PLATE	1								
70	1310 4747 00	SEAL	1								
75	1619 5898 01	HEX. HEAD SCREW	6								
80	1310 4605 00	FLANGE	2								
85	1310 4637 00	GASKET	2								
90	0147 1322 03	HEX. HEAD SCREW	8								
95	1310 4825 00	SHIELD	1								
100	1619 2766 00	HEX. HEAD SCREW	4								
105	1310 4826 00	CLAMP	1								
110	1619 2766 00	HEX. HEAD SCREW	2								
120	0686 3716 09	HEXAGON PLUG	1								
125	0661 1056 00	SEALING WASHER	1								

FUEL SYSTEM - STANDARD

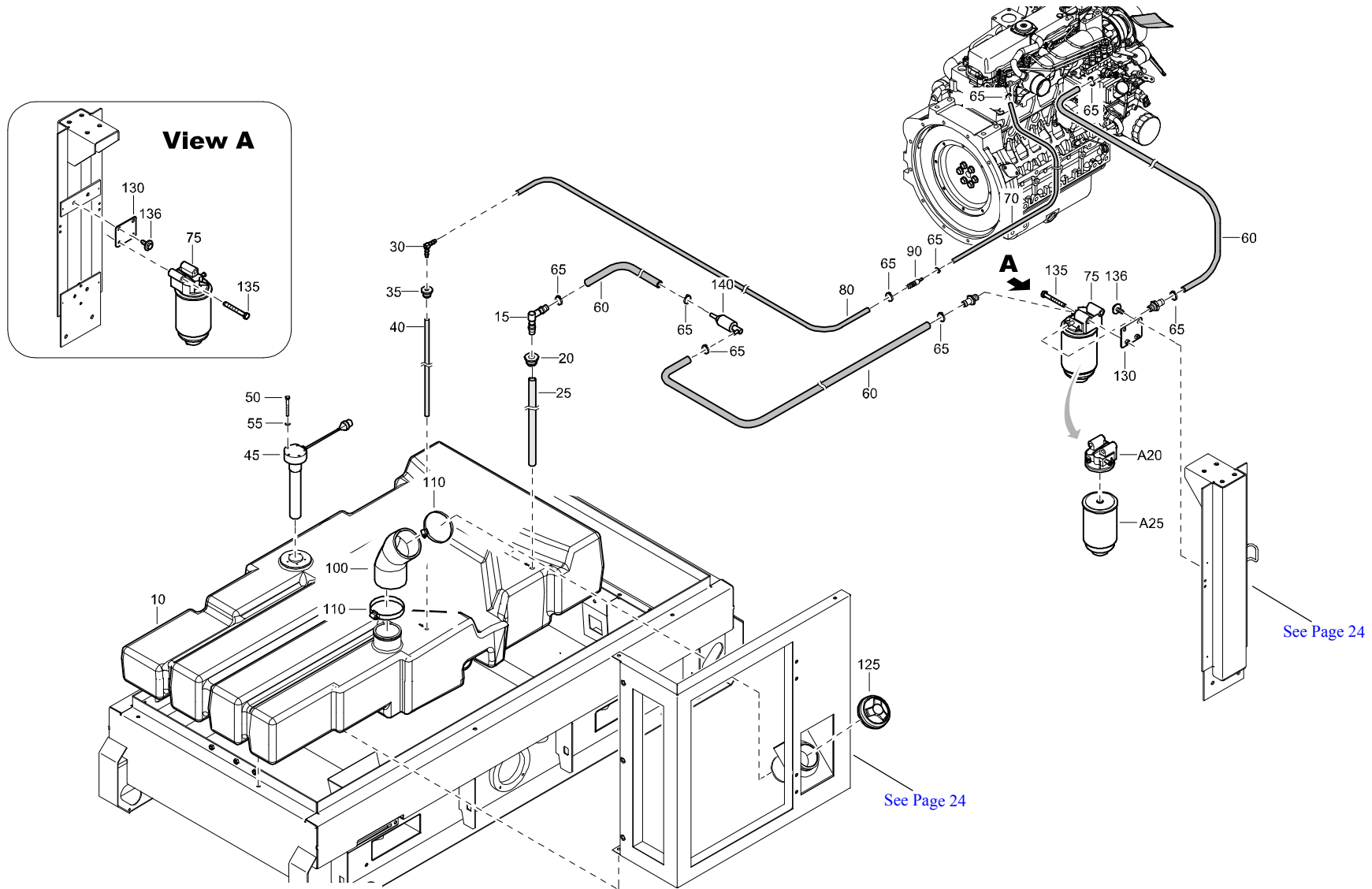

FUEL SYSTEM - STANDARD

REF	PART NUMBER	DESIGNATION	QTY	REF	PART NUMBER	DESIGNATION	QTY	REF	PART NUMBER	DESIGNATION	QTY
10	1310 6025 00	FUELTANK	1								
15	1615 6651 00	ADAPTER	1								
20	1615 6652 00	GROMMET	1								
25	0070 6002 15	PLASTIC TUBE	AR								
30	1615 8515 01	HOSE NIPPLE	1								
35	1615 8516 01	GROMMET	1								
40	0070 6002 43	PTFE TUBE	AR								
45	1089 0659 16	SENSOR LEVEL	1								
50	0147 1213 03	HEX. HEAD SCREW	5								
55	0301 2318 00	PLAIN WASHER	5								
60	1310 0311 98	HOSE	AR								
65	1310 0323 84	HOSE CLAMP	8								
70	1310 4310 00	FUEL HOSE	AR								
75	1615 8818 80	FILTER FUEL	1								
A20	1615 8818 00	FUEL FILTER HOUSING	1								
A25	1615 8875 00	FUEL FILTER	1								
80	1310 4310 00	FUEL HOSE	AR								
90	1604 5014 00	HOSE NIPPLE	1								
100	1626 1866 01	HOSE	1								
110	0347 6131 00	HOSE CLAMP	2								
125	1615 6947 01	COVER	1								
130	1310 6000 09	BRACKET FUEL FILTER	1								
135	0147 1213 03	HEX. HEAD SCREW	2								
136	1615 5664 00	HEX. HEAD SCREW	2								
140	1310 0315 80	FILTER	1								

CORNER ASSEMBLY - CUBICLE - STANDARD

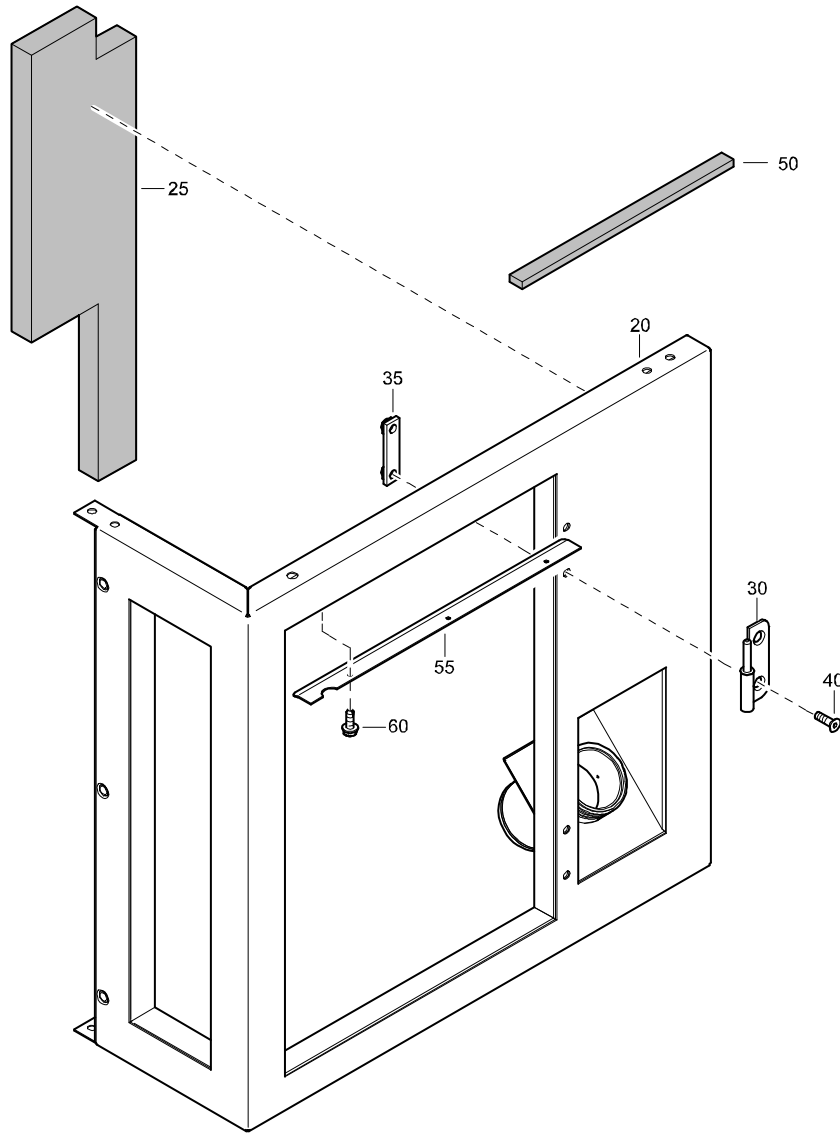

REF	PART NUMBER	DESIGNATION	QTY
-	1310 4829 80	CORNER ASSEMBLY CUBICLE (From page 24)	
20	1310 4829 00	CORNER CUBICLE	1
25	1310 4829 70	FOAM CUBICLE CORNER	1
30	1604 3430 00	HINGE W/PIN	2
35	1615 5684 00	BRACKET HINGE RETAINER	2
40	0216 1324 03	SOC HEAD CAP SCREW	2
50	1615 7057 00	SEAL	2
55	1310 4830 00	PLATE CUBICLE CORNER	1
60	1619 2766 00	SELF TAP SCREW	2

LIFTING BEAM ASSEMBLY - LEFT - STANDARD

REF	PART NUMBER	DESIGNATION	QTY
-	1310 4828 80	VERT LIFTING BEAM LEFT (From page 24)	
20	1310 4828 00	VERT LIFTING BEAM	1
25	1604 5031 00	BRACKET DOOR CATCH	2
30	0215 0006 30	BUTTON HEAD SCREW	4
35	1310 4019 00	SPACER DOOR CATCH	2
40	0291 1108 00	LOCKNUT	4

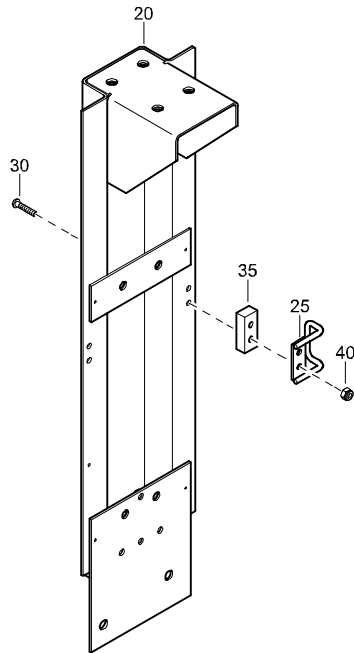

LIFTING BEAM ASSEMBLY - RIGHT - STANDARD

REF	PART NUMBER	DESIGNATION	QTY
-	1310 4828 90	VERT LIFTING BEAM RIGHT (From page 24)	
20	1310 4828 00	VERT LIFTING BEAM	1
25	1604 5031 00	BRACKET DOOR CATCH	1
30	0215 0006 30	BUTTON HEAD SCREW	2
35	1310 4019 00	SPACER DOOR CATCH	1
40	0291 1108 00	LOCKNUT	2

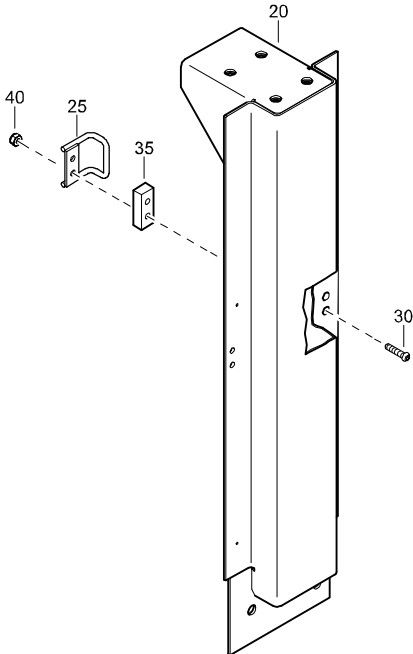

DOOR ASSEMBLY - CUBICLE - STANDARD

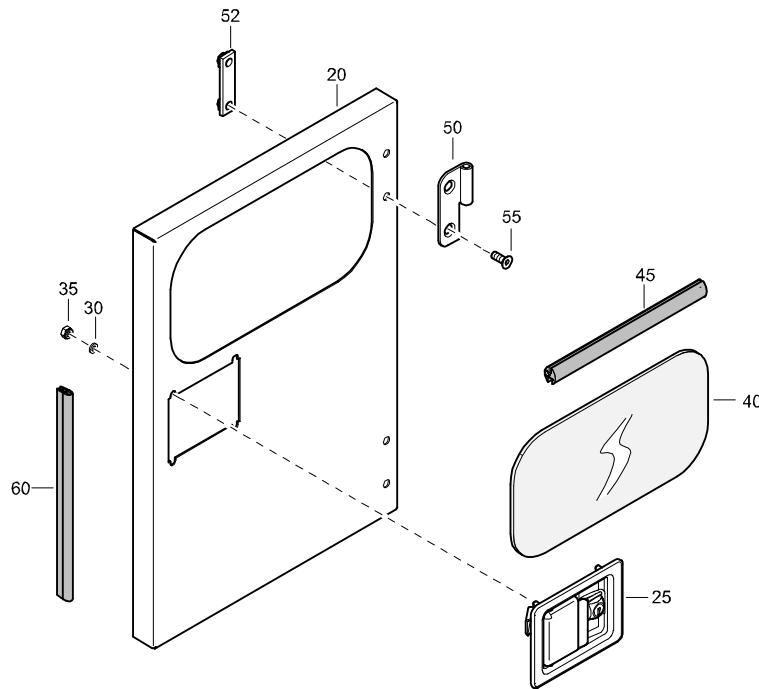

REF	PART NUMBER	DESIGNATION	QTY
-	1310 4831 80	CUBICLE DOOR ASSEMBLY (From page 24)	
20	1310 4831 00	CUBICLE DOOR	1
25	1615 6967 03	HANDLE	1
30	0301 2321 00	FLAT WASHER	4
35	0291 1108 00	LOCKNUT	4
40	1310 6253 00	WINDOW CUBICLE DOOR	1
45	1310 4049 00	SEAL	1
50	1604 3431 00	HINGE W/O PIN	2
52	1615 5684 00	BRACKET HINGE RETAINER	2
55	0216 1324 03	SOC HEAD CAP SCREW	4
60	1619 2795 00	SEAL-EDGE	1

CORNER ASSEMBLY - SMALL - STANDARD

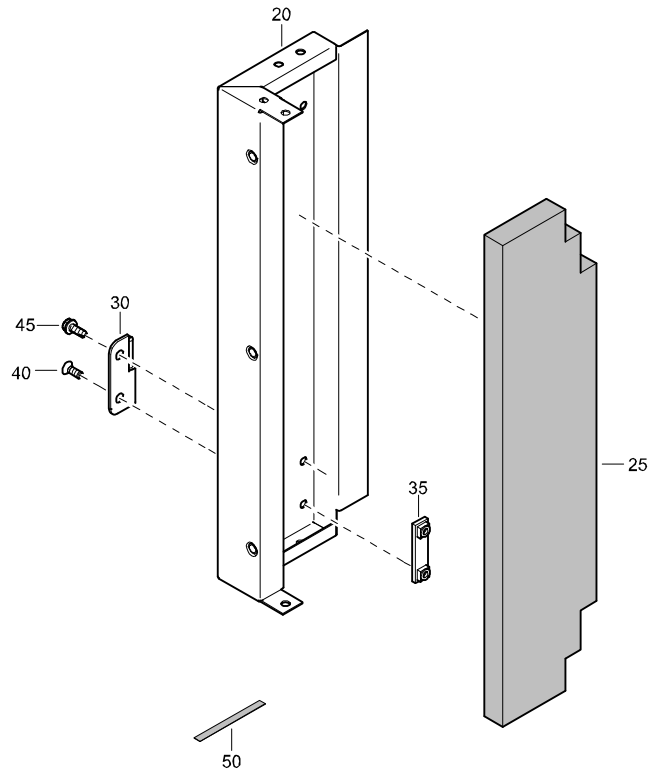

REF	PART NUMBER	DESIGNATION	QTY
-	1310 4833 80	CORNER ASSEMBLY SMALL (From page 24)	
20	1310 4833 00	CORNER SMALL	1
25	1310 4833 70	INSULATION CORNER SMALL	1
30	1604 3430 00	HINGE W/PIN	2
35	1615 5684 00	BRACKET HINGE RETAINER	2
40	0216 1324 03	SOC HEAD CAP SCREW	2
45	1619 2766 00	SELF TAP SCREW	2
50	1615 7057 00	SEAL	AR

CORNER ASSEMBLY - FRONT RIGHT - STANDARD

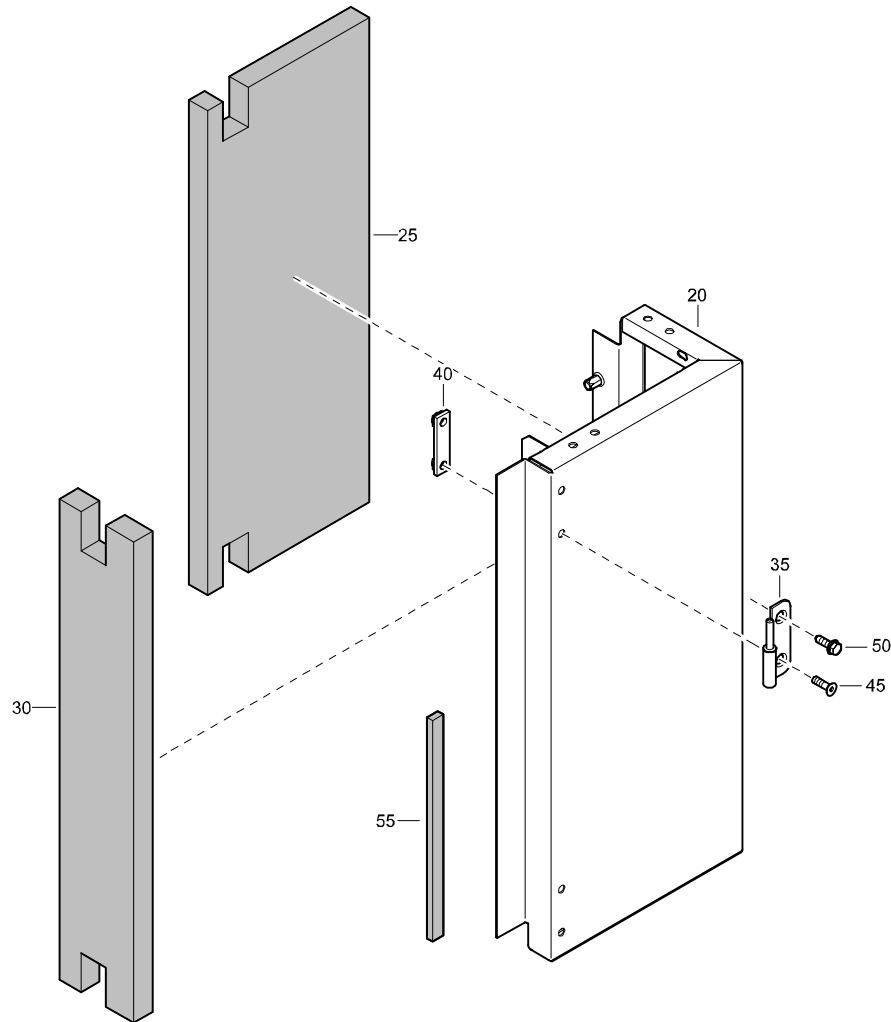

REF	PART NUMBER	DESIGNATION	QTY
-	1310 4834 80	CORNER ASSEMBLY FRONT RIGHT (From page 24)	
20	1310 4834 00	CORNER FRONT RIGHT ASSY	1
25	1310 4834 70	INSULATION CORNER FRONT	1
30	1310 4834 71	INSULATION CORNER FRONT	1
35	1604 3430 00	HINGE W/PIN	2
40	1615 5684 00	BRACKET HINGE RETAINER	2
45	0216 1324 03	SOC HEAD CAP SCREW	2
50	1619 2766 00	SELF TAP SCREW	2
55	1615 7057 00	SEAL	2

CORNER ASSEMBLY - FRONT LEFT - STANDARD

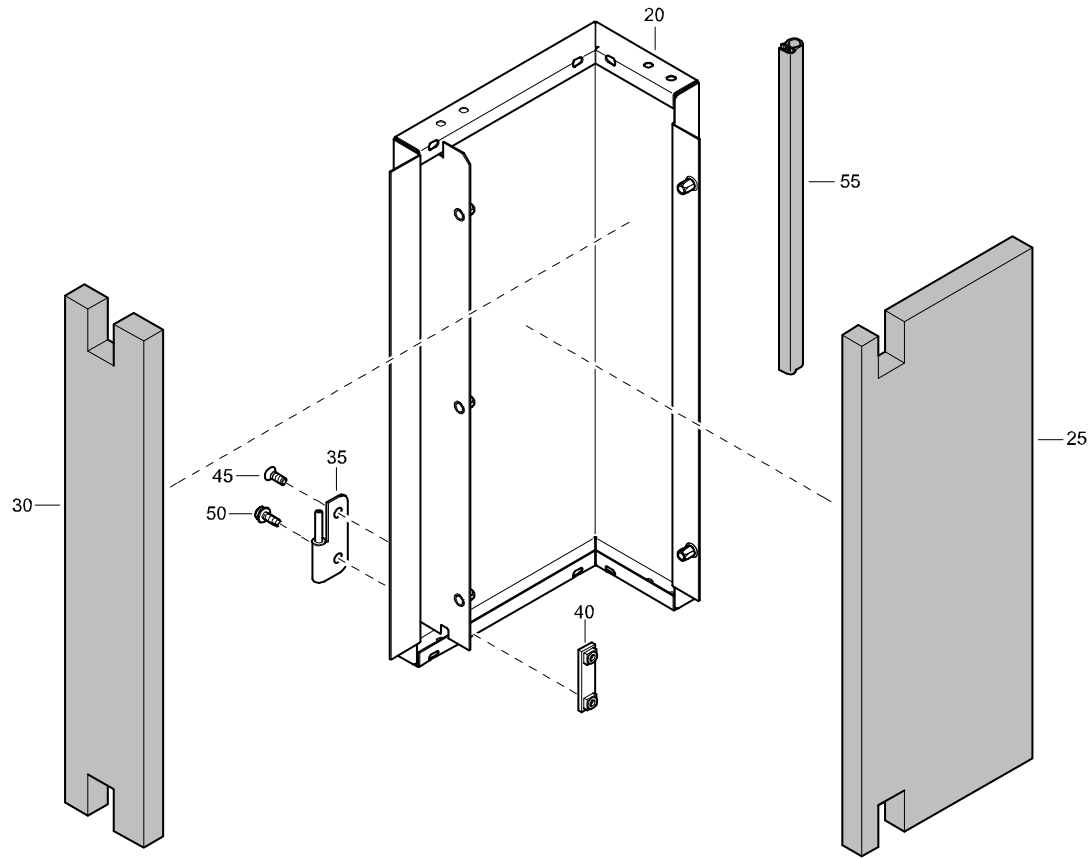

REF	PART NUMBER	DESIGNATION	QTY
-	1310 4835 80	CORNER ASSEMBLY FRONT LEFT (From page 24)	
20	1310 4835 00	CORNER FRONT LEFT	1
25	1310 4834 70	INSULATION CORNER FRONT	1
30	1310 4834 71	INSULATION CORNER FRONT	1
35	1604 3430 00	HINGE W/PIN	2
40	1615 5684 00	BRACKET HINGE RETAINER	2
45	0216 1324 03	SOC HEAD CAP SCREW	2
50	1619 2766 00	SELF TAP SCREW	2
55	1615 7057 00	SEAL	2

DOOR ASSEMBLY - STANDARD

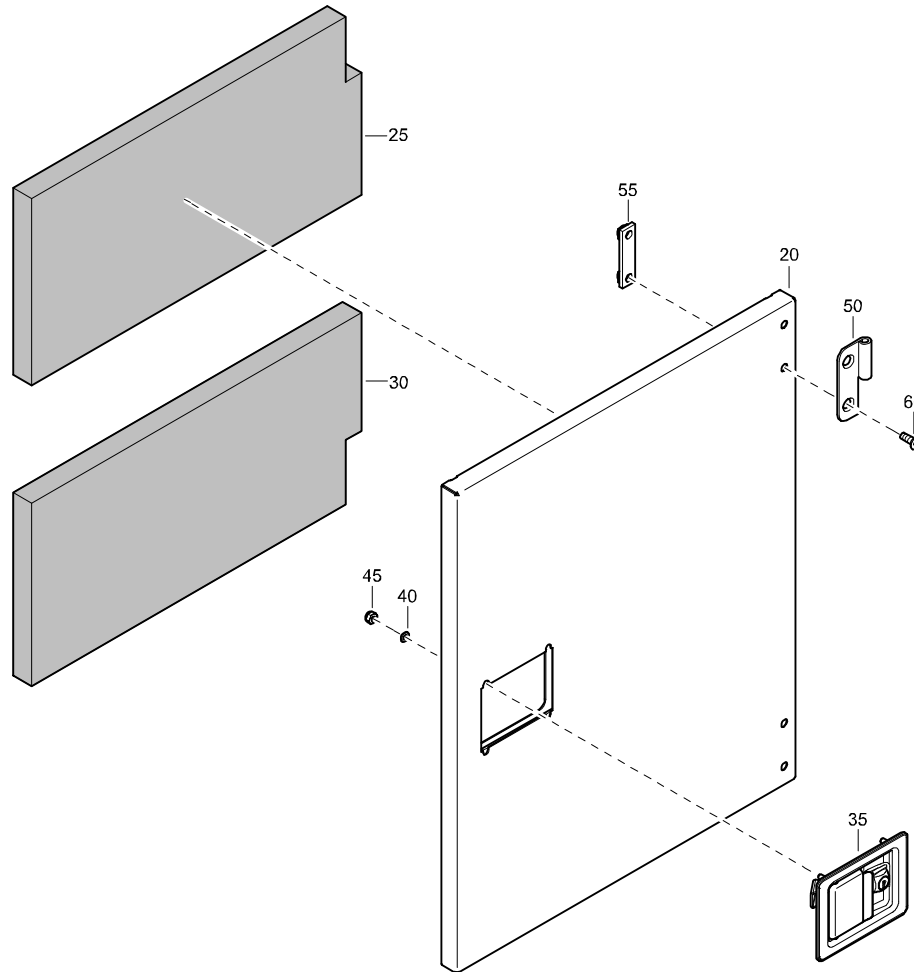

REF	PART NUMBER	DESIGNATION	QTY
-	1310 4836 80	DOOR ASSEMBLY (From page 24)	
20	1310 4836 00	DOOR	1
25	1310 4836 70	INSULATION DOOR	1
30	1310 4836 71	INSULATION DOOR	1
35	1615 6967 03	HANDLE	1
40	0301 2321 00	FLAT WASHER	4
45	0291 1108 00	LOCKNUT	4
50	1604 3431 00	HINGE W/O PIN	2
55	1615 5684 00	BRACKET HINGE RETAINER	2
60	0216 1324 03	SOC HEAD CAP SCREW	4

DOOR ASSEMBLY - STANDARD

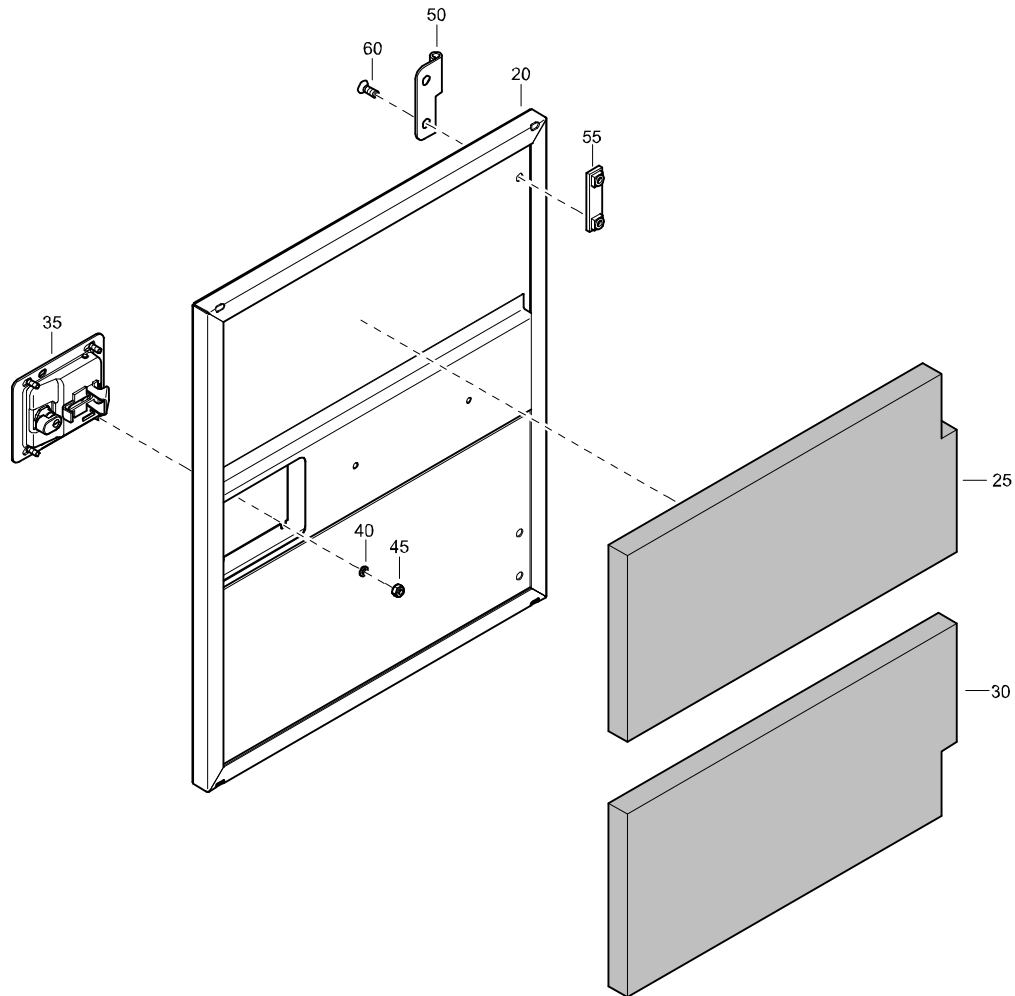

REF	PART NUMBER	DESIGNATION	QTY
-	1310 4837 80	DOOR ASSEMBLY (From page 24)	
20	1310 4836 00	DOOR	1
25	1310 4836 70	INSULATION DOOR	1
30	1310 4837 70	INSULATION DOOR	1
35	1615 6967 03	HANDLE	1
40	0301 2321 00	FLAT WASHER	4
45	0291 1108 00	LOCKNUT	4
50	1604 3431 00	HINGE W/O PIN	2
55	1615 5684 00	BRACKET HINGE RETAINER	2
60	0216 1324 03	SOC HEAD CAP SCREW	4

ROOF ASSEMBLY - STANDARD

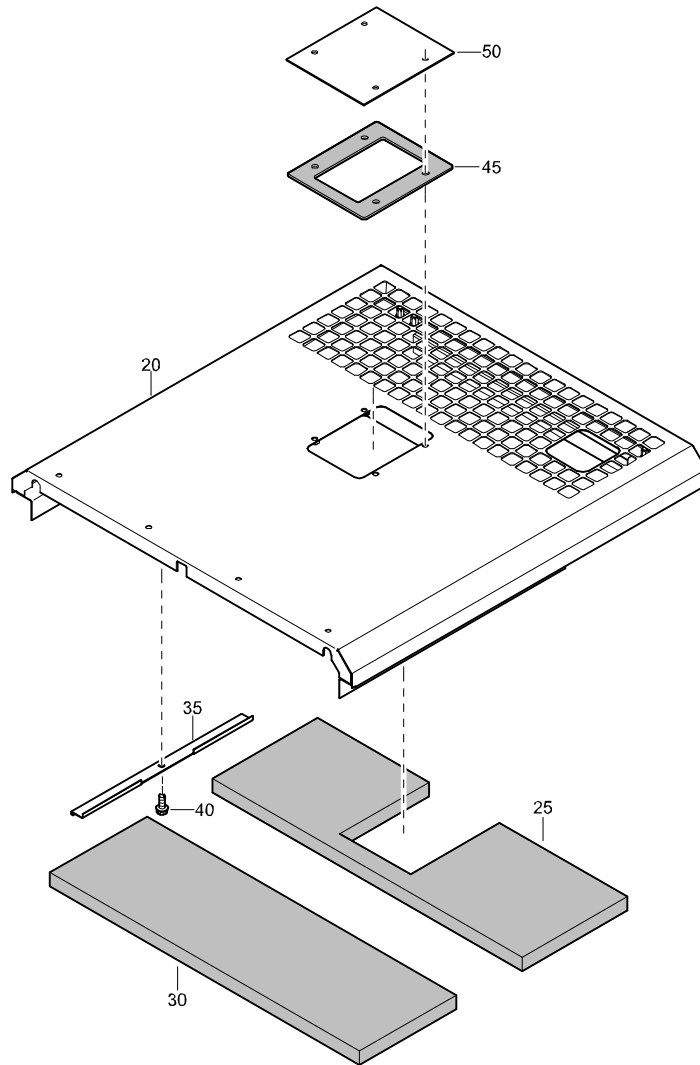

REF	PART NUMBER	DESIGNATION	QTY
-	1310 4838 80	ROOF ASSEMBLY (From page 24)	
20	1310 4838 00	ROOF	1
25	1310 4838 70	INSULATION ROOF	1
30	1310 4838 71	INSULATION ROOF	1
35	1310 4839 00	SUPPORT	1
40	1619 2766 00	SELF TAP SCREW	6
45	1310 4840 00	SEAL GASKET	1
50	1310 4841 00	COVER COOLER	1

ROOF ASSEMBLY - REAR - STANDARD

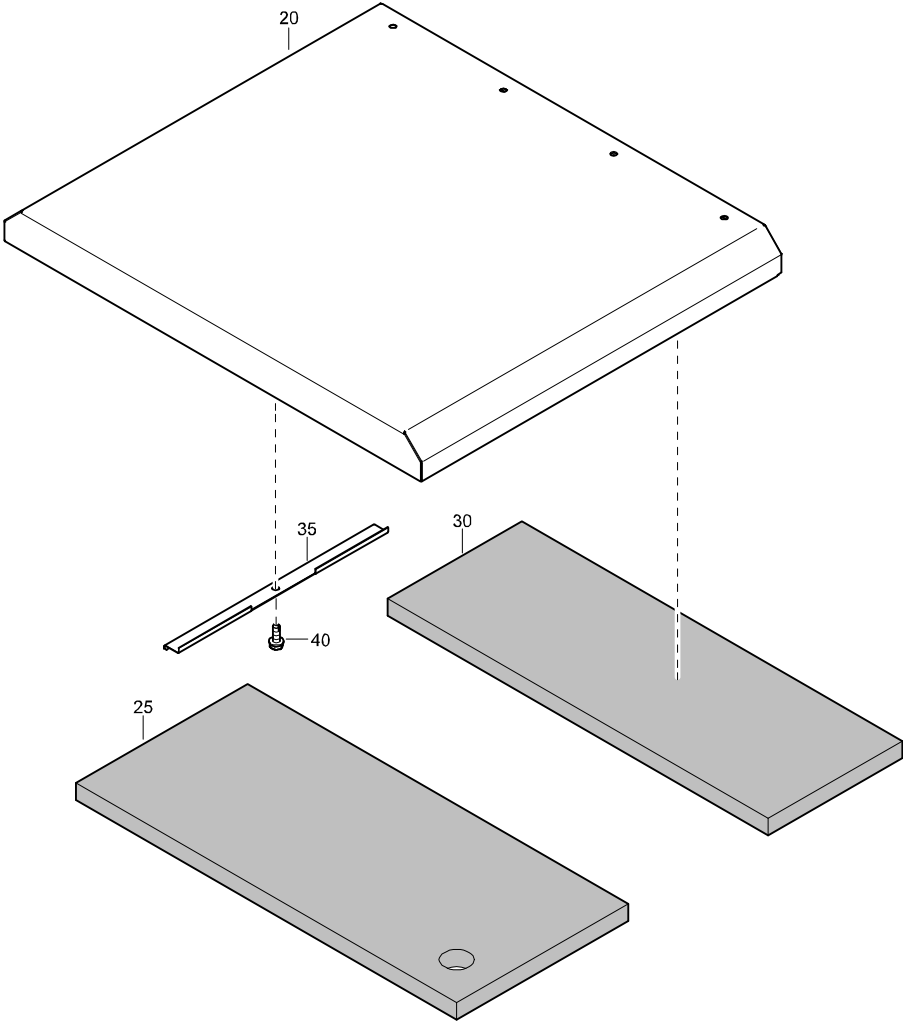

REF	PART NUMBER	DESIGNATION	QTY
-	1310 4842 80	ROOF ASSEMBLY REAR (From page 24)	
20	1310 4842 00	ROOF REAR	1
25	1310 4842 70	INSULATION ROOF REAR	1
30	1310 4842 71	INSULATION ROOF REAR	1
35	1310 4843 00	SUPPORT	1
40	1619 2766 00	SELF TAP SCREW	2

SERVICE PANEL ASSEMBLY - STANDARD

REF	PART NUMBER	DESIGNATION	QTY
-	1310 4844 80	PANEL ASSEMBLY SERVICE (From page 24)	
20	1310 4844 00	PANEL SERVICE	1

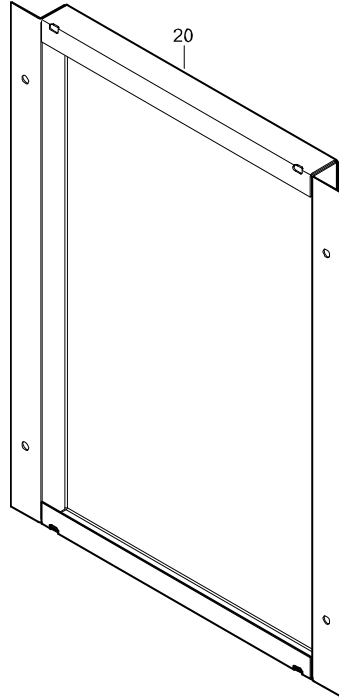

BAFFLE ASSEMBLY - AIR INLET - STANDARD

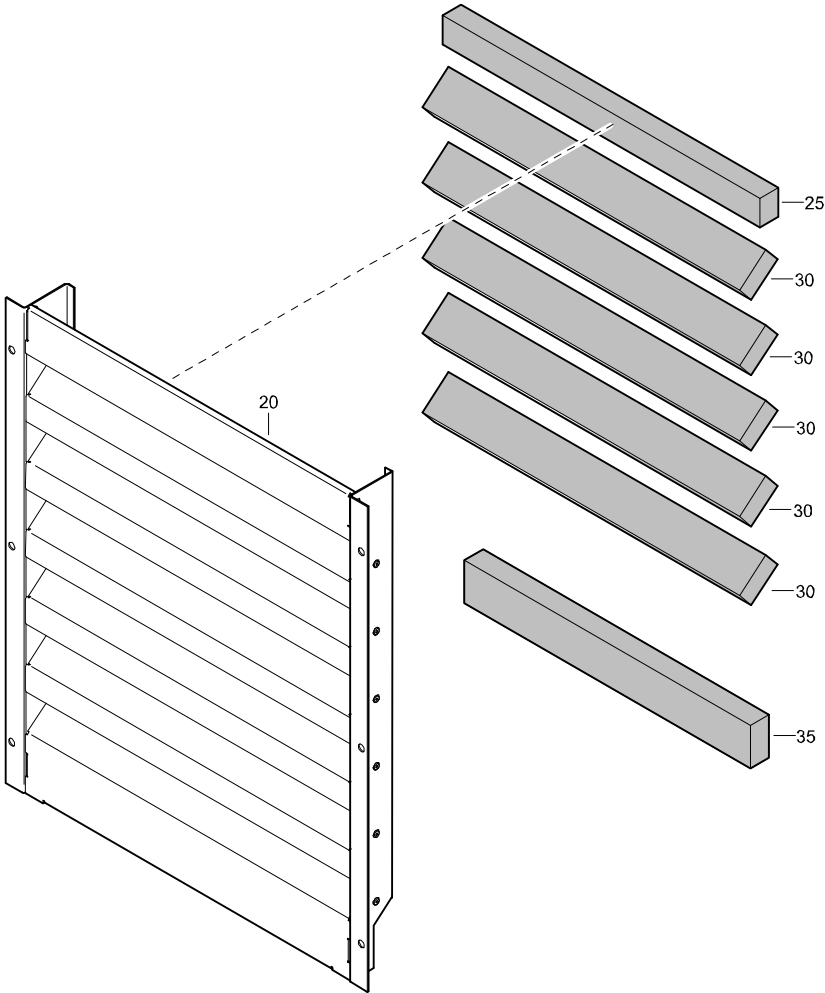

REF	PART NUMBER	DESIGNATION	QTY
-	1310 4845 80	BAFFLE ASSEMBLY AIR INLET (From page 24)	
20	1310 4845 00	BAFFLE AIR INLET	1
25	1310 4845 70	INSULATION BAFFLE AIR IN	1
30	1310 4845 71	INSULATION BAFFLE AIR IN	1
35	1310 4845 72	INSULATION BAFFLE AIR IN	5

CONTROL PANEL ASSEMBLY - STANDARD

REF	PART NUMBER	DESIGNATION	QTY
-	1310 4901 80	CONTROL PANEL ASSEMBLY (From page 30, 31)	
10	1310 4901 00	DOOR CUBICLE	1
20	1604 9382 01	CONTROLLER	1
30	1089 0341 01	RELAY	1
40	1089 0358 01	SOCKET-EL	1
50	1089 9381 05	AMMETER	1
60	1089 9383 01	VOLTMETER	1
70	1089 9082 22	SWITCH	1
80	1089 9423 01	FUSE	1
90	1089 9371 21	POTMETER	1
100	1089 9371 50	LOCK	1
110	1089 9622 04	SWITCH 3 POS	1
120	1089 9354 01	PANEL LIGHT	1
130	1619 1609 00	LAMP	1
140	1088 0500 05	COVER	1
150	1626 2526 00	HANDGRIP	1
160	1089 9622 05	CONTACT	1
170	1089 9622 08	CONTACT	1

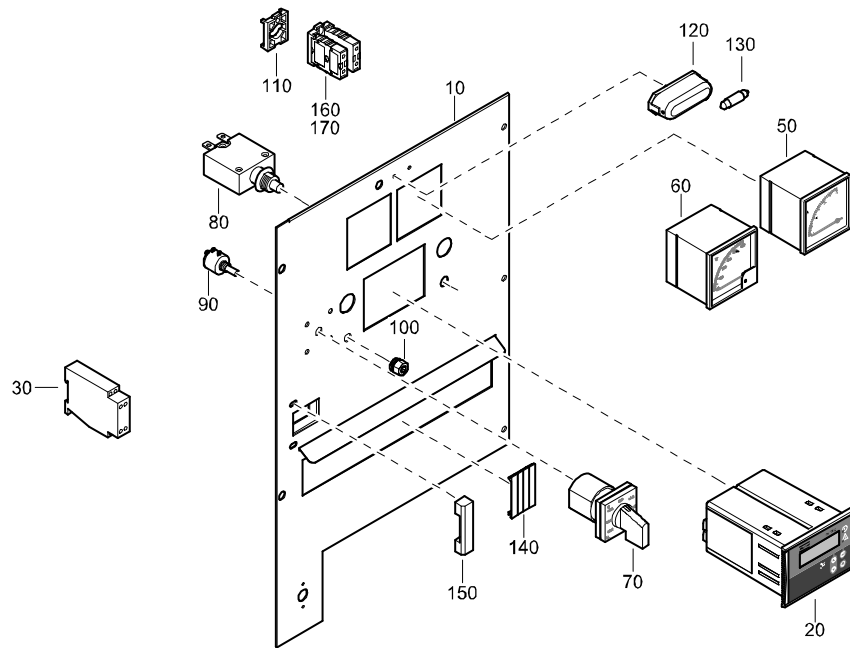

1310073337 - Switch 3 Pos
1310073355 - Terminal
Contact - Qty 2

VALVE AND FITTINGS - FOR GENERATOR WITH EXTERNAL FUEL TANK CONNECTION - OPTIONS

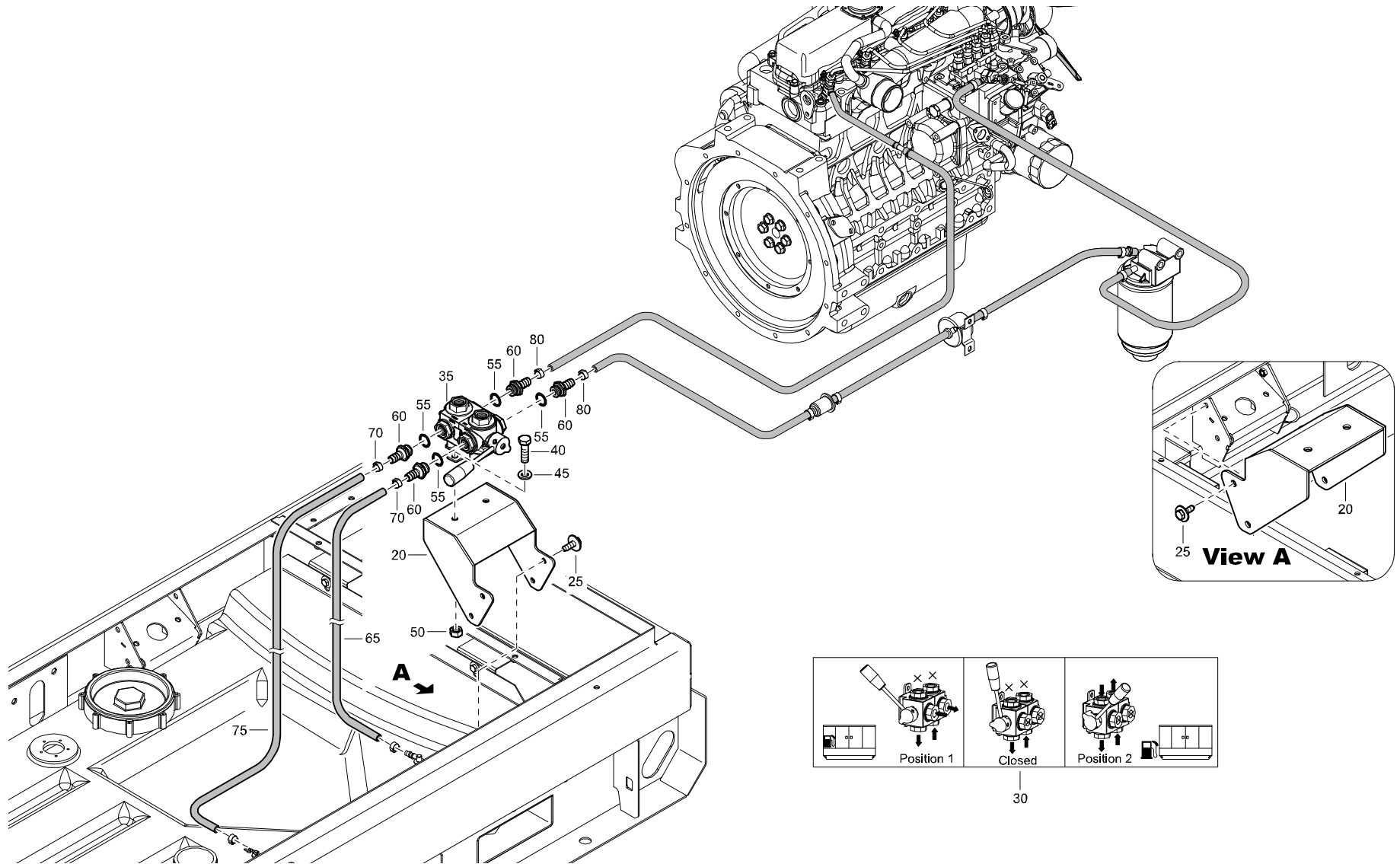

VALVE AND FITTINGS - FOR GENERATOR WITH EXTERNAL FUEL TANK CONNECTION - OPTIONS

REF	PART NUMBER	DESIGNATION	QTY	REF	PART NUMBER	DESIGNATION	QTY	REF	PART NUMBER	DESIGNATION	QTY
20	1626 1851 01	SUPPORT	1								
25	1615 5664 00	HEX. HEAD SCREW	4								
30	1079 9925 00	INFORMATION LABEL	1								
35	1604 6111 01	VALVE	1								
40	0147 1363 03	HEX. HEAD SCREW	2								
45	0301 2344 00	PLAIN WASHER	4								
50	0266 2111 00	HEXAGON NUT	2								
55	0653 1124 00	FLAT GASKET	4								
60	0571 0020 14	HOSE NIPPLE	4								
65	0075 4005 55	FUEL HOSE	AR								
70	1604 4137 00	HOSE CLIP	2								
75	0071 8401 63	FUEL HOSE	AR								
80	1604 4137 00	HOSE CLIP	2								

ELECTRICAL SYSTEM - WITH BATTERY SWITCH - OPTIONS

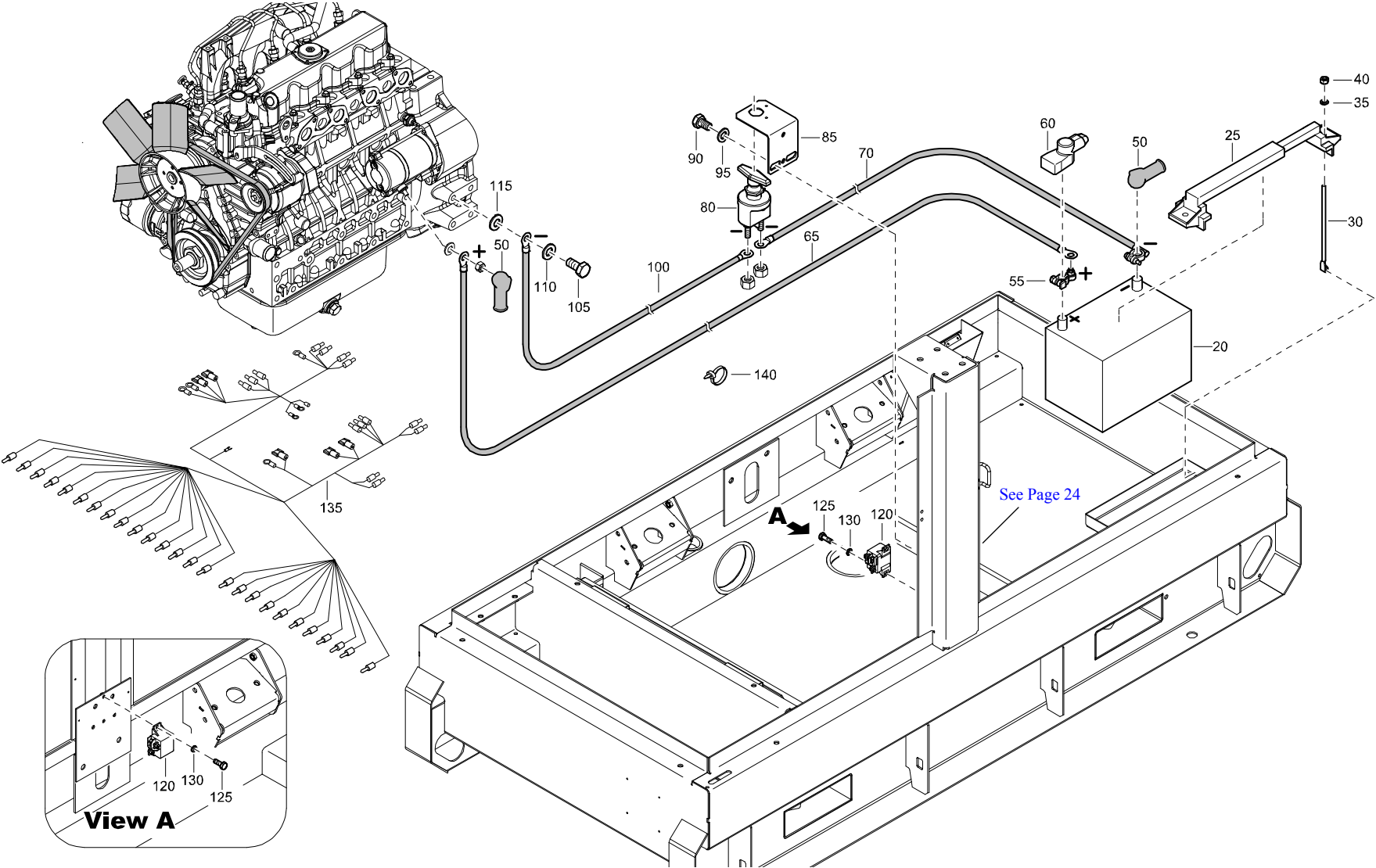

ELECTRICAL SYSTEM - WITH BATTERY SWITCH - OPTIONS

REF	PART NUMBER	DESIGNATION	QTY	REF	PART NUMBER	DESIGNATION	QTY	REF	PART NUMBER	DESIGNATION	QTY
20	1310 6000 17	BATTERY	1								
25	1310 6000 53	BATTERY BRACKET	1								
30	1310 0311 67	BOLT-J	2								
35	0333 2225 00	SPRING WASHER	2								
40	0268 3205 00	HEX NUT	2								
50	1310 0363 91	INSULATOR TERMINAL	2								
55	1604 5043 00	CLAMP	1								
60	1604 7216 00	COVER BATTERY CABLE	1								
65	1310 4098 00	BATTERY CABLE +VE	1								
70	1310 0333 25	BATTERY CABLE -VE	1								
80	1089 0584 01	BATTERY SWITCH	1								
85	1604 3473 02	BRACKET	1								
90	0144 3360 00	HEX HEAD SCREW	2								
95	0301 2358 00	FLAT WASHER	5								
100	1310 3128 61	BATTERY CABLE +VE	1								
105	0147 1400 03	HEX HEAD SCREW	1								
110	0301 2358 00	FLAT WASHER	1								
115	1088 0019 03	CONTACT WASHER	1								
120	1310 0304 71	RELAY	1								
125	0147 1246 03	HEX HEAD SCREW	2								
130	0301 2321 00	FLAT WASHER	2								
135	1626 1791 03	WIRE HARNESS	1								
140	1088 1301 02	CABLE TY	15								

TRAILER ASSEMBLY - OPTIONS

New Trailer Assy - 1310030701

Not Illustrated			
Ref	Part Number	Designation	Qty
90	1310 0724 01	Wire Harness	1

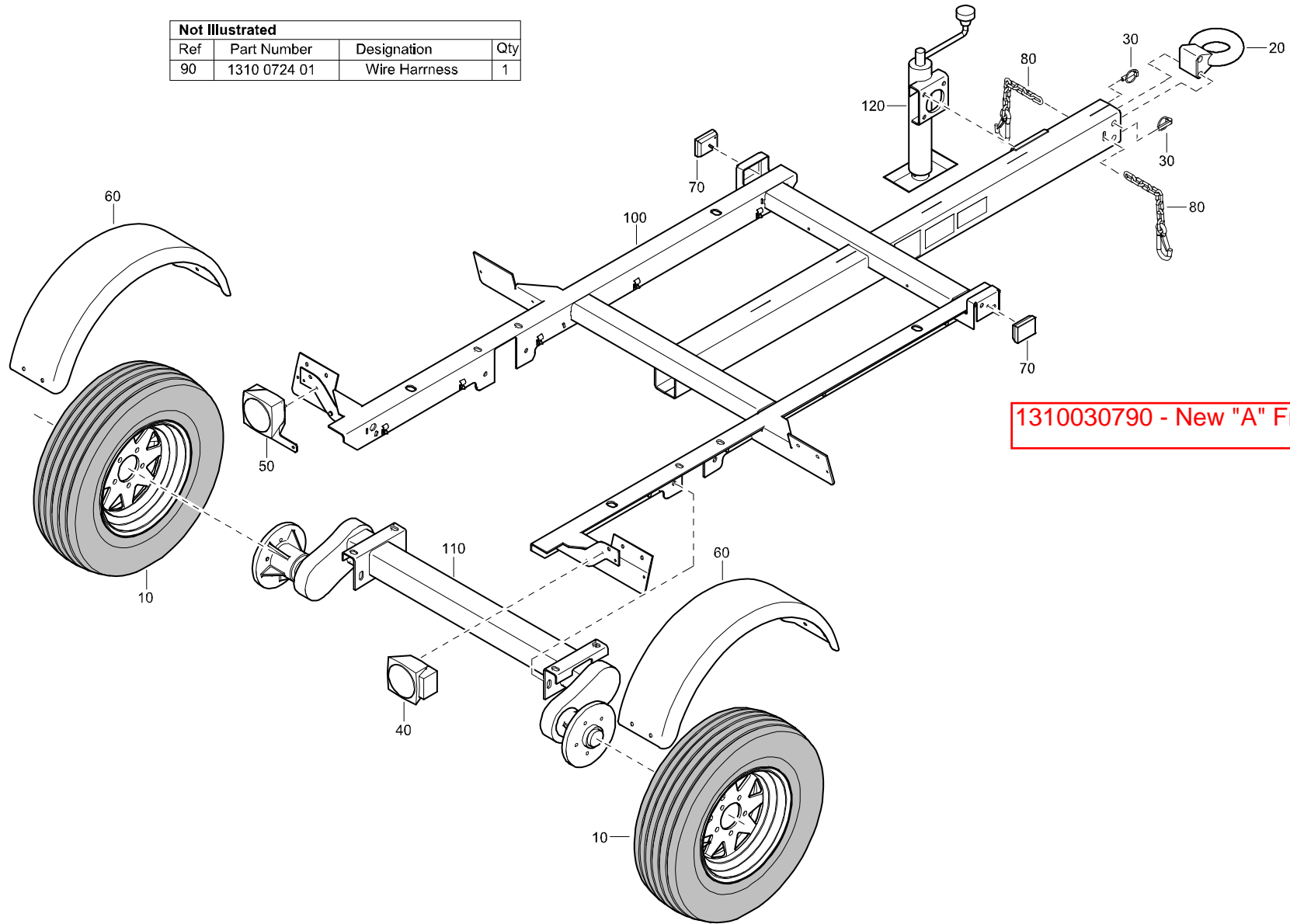

1310030790 - New "A" Frame Style

TRAILER ASSEMBLY - OPTIONS

REF	PART NUMBER	DESIGNATION	QTY	REF	PART NUMBER	DESIGNATION	QTY	REF	PART NUMBER	DESIGNATION	QTY
10	1310 0723 96	TIRE AND WHEEL ASSY	2								
20	1310 0346 73	TOWING EYE	1								
30	1310 0723 97	PIN	1								
40	1310 0723 98	TAIL LIGHT	1								
50	1310 0367 25	TAIL LIGHT ASSY	1								
60	1310 0723 99	FENDER	2								
70	1310 0367 21	LIGHT MARKER	2								
80	1310 0308 14	SAFETY CHAIN	2								
90	1310 0724 01	WIRE HARNESS	1								
100	1310 0724 02	FRAME	1								
110	1310 0723 94	AXLE ASSY	1								
120	1310 0723 95	JACK TOUNGUE	1								

BATTERY CHARGER - OPTIONS

REF	PART NUMBER	DESIGNATION	QTY
20	1900 1037 49	BATTERY CHARGER	1
A490	1310 6000 48	BATTERY CHARGER	1

