



The Benchmark of Service

Service Bulletin No. CO20050706 Rev A
Subject: Volute and Drain Cover Change
Model: QP- 3TE, QP- 3TH
Product Group: Trash Pumps
Date: 06 Jul 2005

SERVICE BULLETIN

Group: CO

Mandatory
 Information
 Recommended Change

Series/Parts Affected: QP-3TE and QP-3TH Trash Pumps

Machines that may be affected:

3TE-0001 to 3TE-0097

3TH-0001 to 3TH-1969

[Note: Since serial number 3TH-1970 the cap screw was changed which almost totally eliminated the problem. Since then there had only been 3 incidences of the volute cap screws coming loose but we recognize that there may be a handful of units since serial number 3TH-1969 that may encounter this problem.]

SERVICE INFORMATION	
The volute under certain conditions would loosen from the drain cover creating excessive wear on the impeller and possibly damaging the impeller. The volute and drain cover design was changed from a 2-bolt fastening system to a 4-bolt system. This problem did not occur in all pumps, usually the problem was noticed very soon after a new pump was placed into service.	

NEW PARTS INFORMATION – COUNTERMEASURE ASSEMBLY KIT			
Qty	Part #	Description	Remarks
1ea.	3TVDCKIT	Kit, Drain Cover/Volute Assembly	Consists of the following parts:
1	1992-100172	Drain Cover- (4 post)	Replaces 1992-100171
1	1992-000134	Volute casing	Replaces 1992-000133
1	1992-250700	Wear Plate	[No change in design]
4	013119-0823	Cap Screw (Volute casing)	Replaces 014109-0820
3	020449-0060	U-nut	[No change in design]
4	045129-0080	Spring Washer	[No change in design]
1	048057-0850	O-ring (volute casing)	[No change in design]

WARRANTY PARTS ORDERING INSTRUCTIONS
To replace your volute/drain cover assembly to the new style please send in the attached fax order form (page 3 of this bulletin) and the quantity of kits required will be shipped to you.

INSTALLATION INSTRUCTIONS

Remove drain cover with attached volute, remove O-ring from center of volute. Add new O-ring to center of new drain cover-volute assembly and place back into pump. The volute cap screws have already been fastened with Loctite and assembled with the proper torque (see the next section for details of fastening the volute to the drain cover if required for future servicing).

ADDITIONAL SERVICE INFORMATION

If the volute is ever removed from the drain cover use the following procedure to assure the volute cap screws are re-attached properly:

- Use Loctite thread cleaner on cap screws before re-using
- Use Loctite # 243 on volute cap screws and tighten to torque of 130-160 in-lbs.

Old Style (2-post)

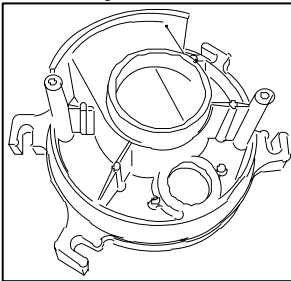

New Style (4-post)

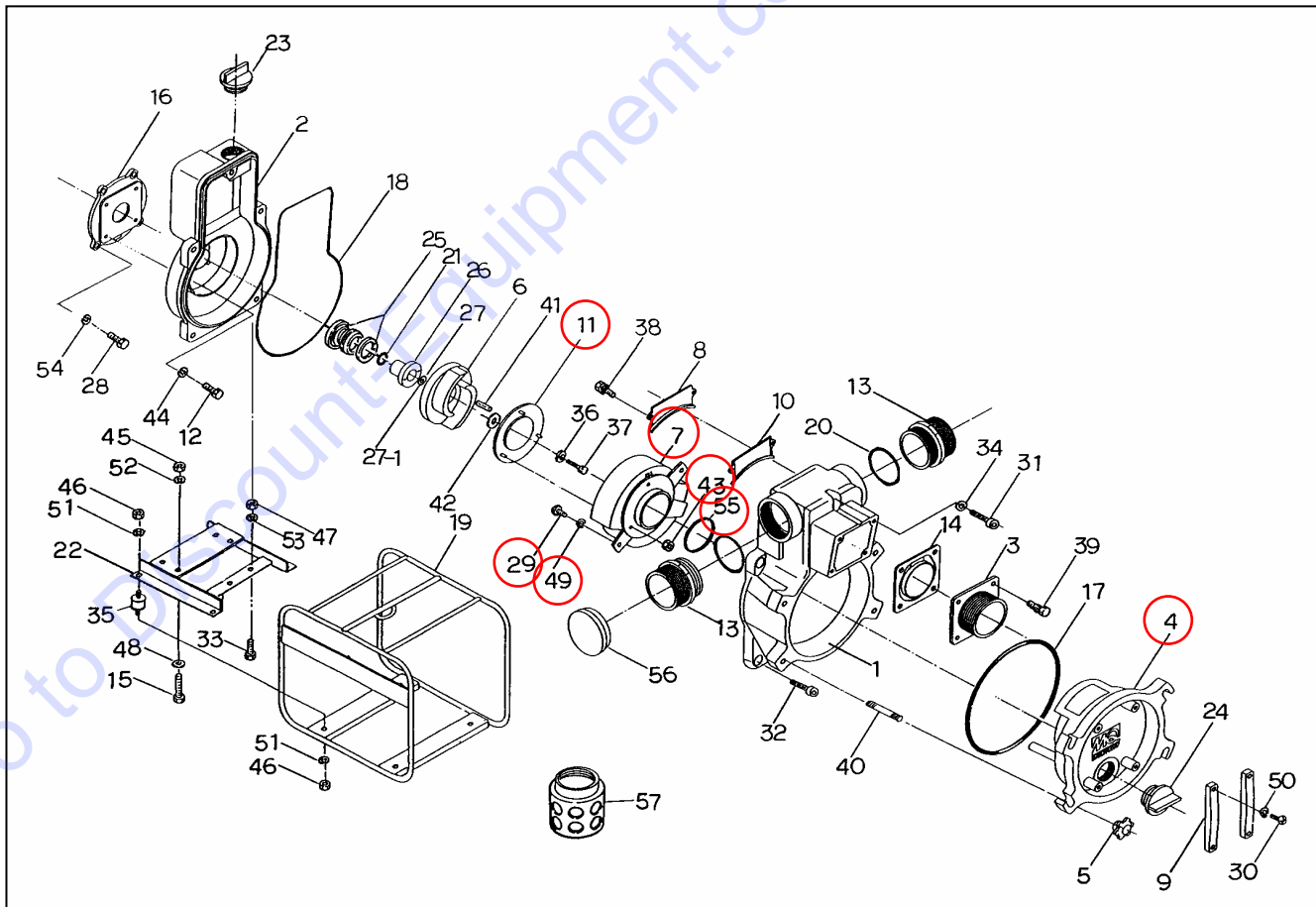
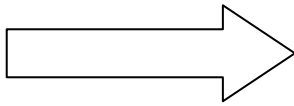
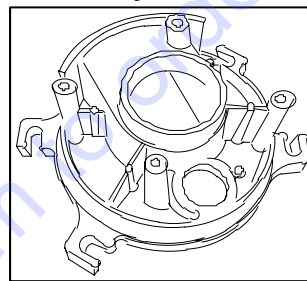

- Parts Order Form on next page -

PARTS FINDER

**Search Website
by Part Number**



**Search Manual
Library For Parts
Manual & Lookup Part
Numbers – Purchase
or Request Quote**

Search Manuals

Enter your information to help us find the right parts manual for your machine.

* Brand:

* Model:

* Serial:

* Part Number:

SEARCH

**Can't Find Part or
Manual? Request Help
by Manufacturer,
Model & Description**

Parts Order Form

Please fill in the following information to help us find the right part for your machine.

Manufacturer:	<input type="text"/>
Model:	<input type="text"/>
Description:	<input type="text"/>
Part Number:	<input type="text"/>
Quantity:	<input type="text"/>
Notes:	<input type="text"/>

Submit

Discount-Equipment.com is your online resource for quality parts & equipment.

Florida: **561-964-4949** Outside Florida TOLL FREE: **877-690-3101**

Need parts?

Click on this link: <http://www.discount-equipment.com/category/5443-parts/> and choose one of the options to help get the right parts and equipment you are looking for. Please have the machine model and serial number available in order to help us get you the correct parts. If you don't find the part on the website or on one of the online manuals, please fill out the request form and one of our experienced staff members will get back to you with a quote for the right part that your machine needs.

We sell worldwide for the brands: Genie, Terex, JLG, MultiQuip, Mikasa, Essick, Whiteman, Mayco, Toro Stone, Diamond Products, Generac Magnum, Airman, Haulotte, Barreto, Power Blanket, Nifty Lift, Atlas Copco, Chicago Pneumatic, Allmand, Miller Curber, Skyjack, Lull, Skytrak, Tsurumi, Husquvarna Target, Stow, Wacker, Sakai, Mi-T-M, Sullair, Basic, Dynapac, MBW, Weber, Bartell, Bennar Newman, Haulotte, Ditch Runner, Menegotti, Morrison, Contec, Buddy, Crown, Edco, Wyco, Bomag, Laymor, EZ Trench, Bil-Jax, F.S. Curtis, Gehl Pavers, Heli, Honda, ICS/PowerGrit, IHI, Partner, Imer, Clipper, MMD, Koshin, Rice, CH&E, General Equipment, Amida, Coleman, NAC, Gradall, Square Shooter, Kent, Stanley, Tamco, Toku, Hatz, Kohler, Robin, Wisconsin, Northrock, Oztec, Toker TK, Rol-Air, APT, Wylie, Ingersoll Rand / Doosan, Innovatech, Con X, Ammann, Mecalac, Makinex, Smith Surface Prep, Small Line, Wanco, Yanmar