

PARTS MANUAL



MODEL QP3Ti TRASH PUMP (HONDA iGX270UT2QZMD GASOLINE ENGINE)

Revision #3 (05/28/20)



THIS MANUAL MUST ACCOMPANY THE EQUIPMENT AT ALL TIMES.

PARTS FINDER

**Search Website
by Part Number**



**Search Manual
Library For Parts
Manual & Lookup Part
Numbers – Purchase
or Request Quote**

Search Manuals

Enter your information to help us find the right parts manual for your machine.

* Brand:

* Model:

* Serial:

* Part Number:

SEARCH

**Can't Find Part or
Manual? Request Help
by Manufacturer,
Model & Description**

Parts Order Form

Please fill in the following information to help us find the right part for your machine.

Manufacturer:	<input type="text"/>
Model:	<input type="text"/>
Description:	<input type="text"/>
Part Number:	<input type="text"/>
Quantity:	<input type="text"/>
Notes:	<input type="text"/>

Discount-Equipment.com is your online resource for quality parts & equipment.

Florida: **561-964-4949** Outside Florida TOLL FREE: **877-690-3101**

Need parts?

Click on this link: <http://www.discount-equipment.com/category/5443-parts/> and choose one of the options to help get the right parts and equipment you are looking for. Please have the machine model and serial number available in order to help us get you the correct parts. If you don't find the part on the website or on one of the online manuals, please fill out the request form and one of our experienced staff members will get back to you with a quote for the right part that your machine needs.

We sell worldwide for the brands: Genie, Terex, JLG, MultiQuip, Mikasa, Essick, Whiteman, Mayco, Toro Stone, Diamond Products, Generac Magnum, Airman, Haulotte, Barreto, Power Blanket, Nifty Lift, Atlas Copco, Chicago Pneumatic, Allmand, Miller Curber, Skyjack, Lull, Skytrak, Tsurumi, Husquvarna Target, Stow, Wacker, Sakai, Mi-T-M, Sullair, Basic, Dynapac, MBW, Weber, Bartell, Bennar Newman, Haulotte, Ditch Runner, Menegotti, Morrison, Contec, Buddy, Crown, Edco, Wyco, Bomag, Laymor, EZ Trench, Bil-Jax, F.S. Curtis, Gehl Pavers, Heli, Honda, ICS/PowerGrit, IHI, Partner, Imer, Clipper, MMD, Koshin, Rice, CH&E, General Equipment, Amida, Coleman, NAC, Gradall, Square Shooter, Kent, Stanley, Tamco, Toku, Hatz, Kohler, Robin, Wisconsin, Northrock, Oztec, Toker TK, Rol-Air, APT, Wylie, Ingersoll Rand / Doosan, Innovatech, Con X, Ammann, Mecalac, Makinex, Smith Surface Prep, Small Line, Wanco, Yanmar

QP3Ti Centrifugal Pump

Explanation Of Code In Remarks Column..... 4
Suggested Spare Parts 5

Component Drawings

Nameplate And Decals Assembly 6-7
Pump Assembly 8-11
Control Panel Assembly 12-13
Float Switches And Utility Box Assembly 14-15
Frame And Battery Assembly 16-17
Honda iGX270UT2QZMD Service Parts 18-19

NOTICE

Specifications and part numbers are subject to change without notice.

Go to Discount-Equipment.com to order your parts

EXPLANATION OF CODE IN REMARKS COLUMN

The following section explains the different symbols and remarks used in the Parts section of this manual. Use the help numbers found on the back page of the manual if there are any questions.

NOTICE

The contents and part numbers listed in the parts section are subject to change **without notice**. Multiquip does not guarantee the availability of the parts listed.

SAMPLE PARTS LIST

NO.	PART NO.	PART NAME	QTY.	REMARKS
1	12345	BOLT	1	INCLUDES ITEMS W/%
2%		WASHER, 1/4 IN.		NOT SOLD SEPARATELY
2%	12347	WASHER, 3/8 IN. ...	1	MQ-45T ONLY
3	12348	HOSE	A/R	MAKE LOCALLY
4	12349	BEARING	1	S/N 2345B AND ABOVE

NO. Column

Unique Symbols — All items with same unique symbol (@, #, +, %, or >) in the number column belong to the same assembly or kit, which is indicated by a note in the “Remarks” column.

Duplicate Item Numbers — Duplicate numbers indicate multiple part numbers, which are in effect for the same general item, such as different size saw blade guards in use or a part that has been updated on newer versions of the same machine.

NOTICE

When ordering a part that has more than one item number listed, check the remarks column for help in determining the proper part to order.

PART NO. Column

Numbers Used — Part numbers can be indicated by a number, a blank entry, or TBD.

TBD (To Be Determined) is generally used to show a part that has not been assigned a formal part number at the time of publication.

A blank entry generally indicates that the item is not sold separately or is not sold by Multiquip. Other entries will be clarified in the “Remarks” Column.

QTY. Column

Numbers Used — Item quantity can be indicated by a number, a blank entry, or A/R.

A/R (As Required) is generally used for hoses or other parts that are sold in bulk and cut to length.

A blank entry generally indicates that the item is not sold separately. Other entries will be clarified in the “Remarks” Column.

REMARKS Column

Some of the most common notes found in the “Remarks” Column are listed below. Other additional notes needed to describe the item can also be shown.

Assembly/Kit — All items on the parts list with the same unique symbol will be included when this item is purchased.

Indicated by:

“INCLUDES ITEMS W/(unique symbol)”

Serial Number Break — Used to list an effective serial number range where a particular part is used.

Indicated by:

“S/N XXXXX AND BELOW”

“S/N XXXX AND ABOVE”

“S/N XXXX TO S/N XXX”

Specific Model Number Use — Indicates that the part is used only with the specific model number or model number variant listed. It can also be used to show a part is NOT used on a specific model or model number variant.

Indicated by:

“XXXXX ONLY”

“NOT USED ON XXXX”

“Make/Obtain Locally” — Indicates that the part can be purchased at any hardware shop or made out of available items. Examples include battery cables, shims, and certain washers and nuts.

“Not Sold Separately” — Indicates that an item cannot be purchased as a separate item and is either part of an assembly/kit that can be purchased, or is not available for sale through Multiquip.

SUGGESTED SPARE PARTS

QP3Ti TRASH PUMP 1 TO 3 UNITS

Qty.	P/N	Description
1	KIT3TE	MECHANICAL SEAL KIT
1	1992040033	ASSY IMPELLER KIT
1	43342012400011	IMPELLER WASHER
1	0480570850	O-RING, VOLUTE CASING
2	0631211159	CAP, FLOOD/DRAIN W/O-RING
2	1992108050	CAP

HONDA iGX270UT2QZMD GASOLINE ENGINE 1 TO 3 UNITS

Qty.	P/N	Description
3	17210Z5KW00	ELEMENT COMP. A/C
1	17218ZE2505	FILTER, OUTER A/C
3	9807955846	SPARK PLUG
1	17620Z4H900	CAP COMP. FUEL TANK
1	9820040750	FUSE, MINI 7.5A
1	9820043000	FUSE, MINI 30A

NOTICE

Part numbers on this Suggested Spare Parts list may supersede/replace the part numbers shown in the following parts lists.

NAMEPLATE AND DECALS ASSEMBLY

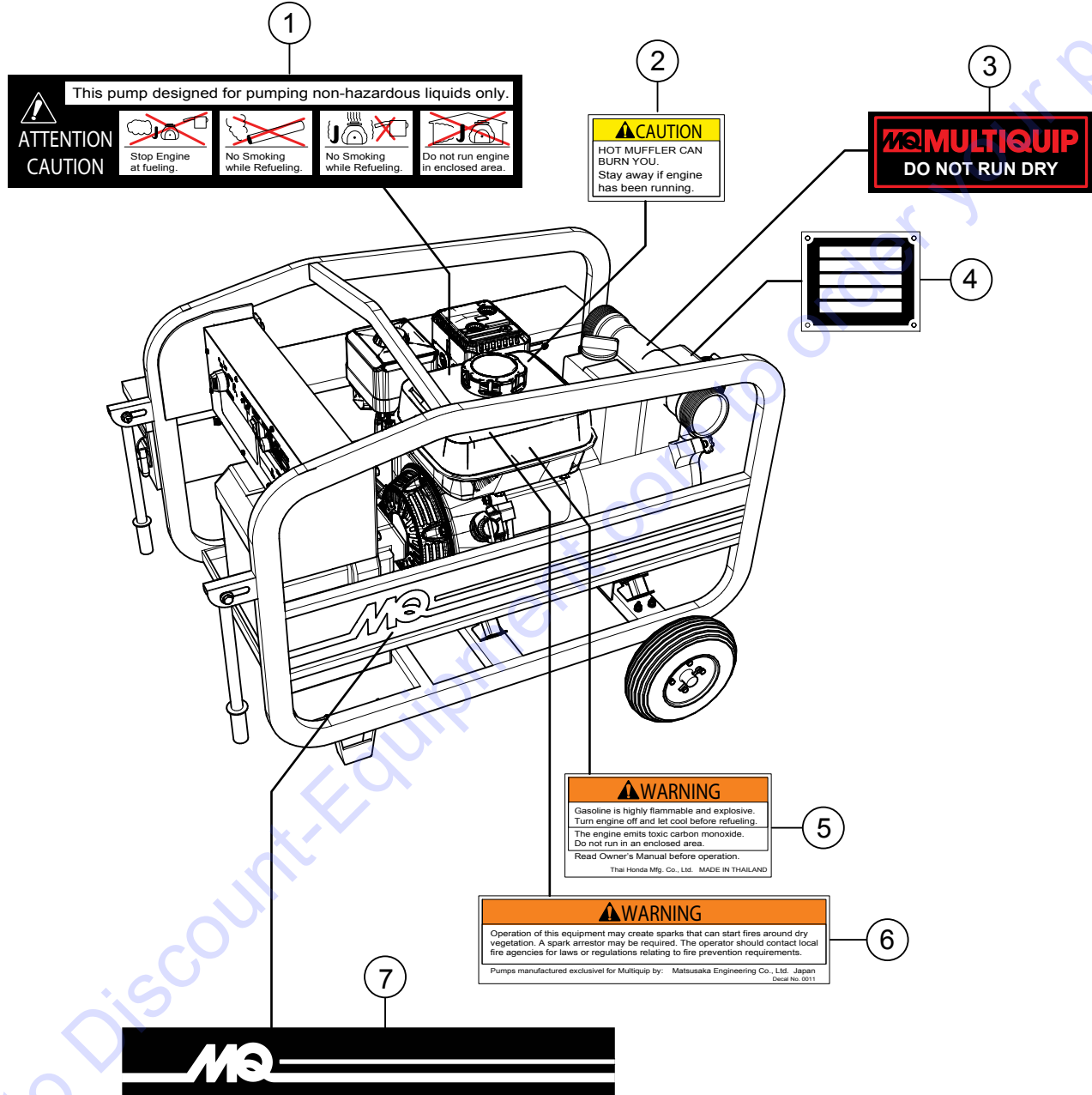

NAMEPLATE AND DECALS ASSEMBLY

<u>NO.</u>	<u>PART NO.</u>	<u>PART NAME</u>	<u>QTY.</u>	<u>REMARKS</u>
1	2200121	DECAL, CAUTION, NO SMOKING	1	
2	TBD	DECAL, CAUTION, HOT MUFFLER	1	
3	2200201	DECAL, DO NOT RUN PUMP DRY	1	
4		SERIAL PLATE	1	
5	TBD	DECAL, WARNING, FLAMMABLE	1	
6	2200231	DECAL, WARNING, START FIRES	1	
7	2200131	DECAL, MQ LOGO/STRIPE	1	

Go to Discount-Equipment.com to order your parts

PUMP ASSEMBLY

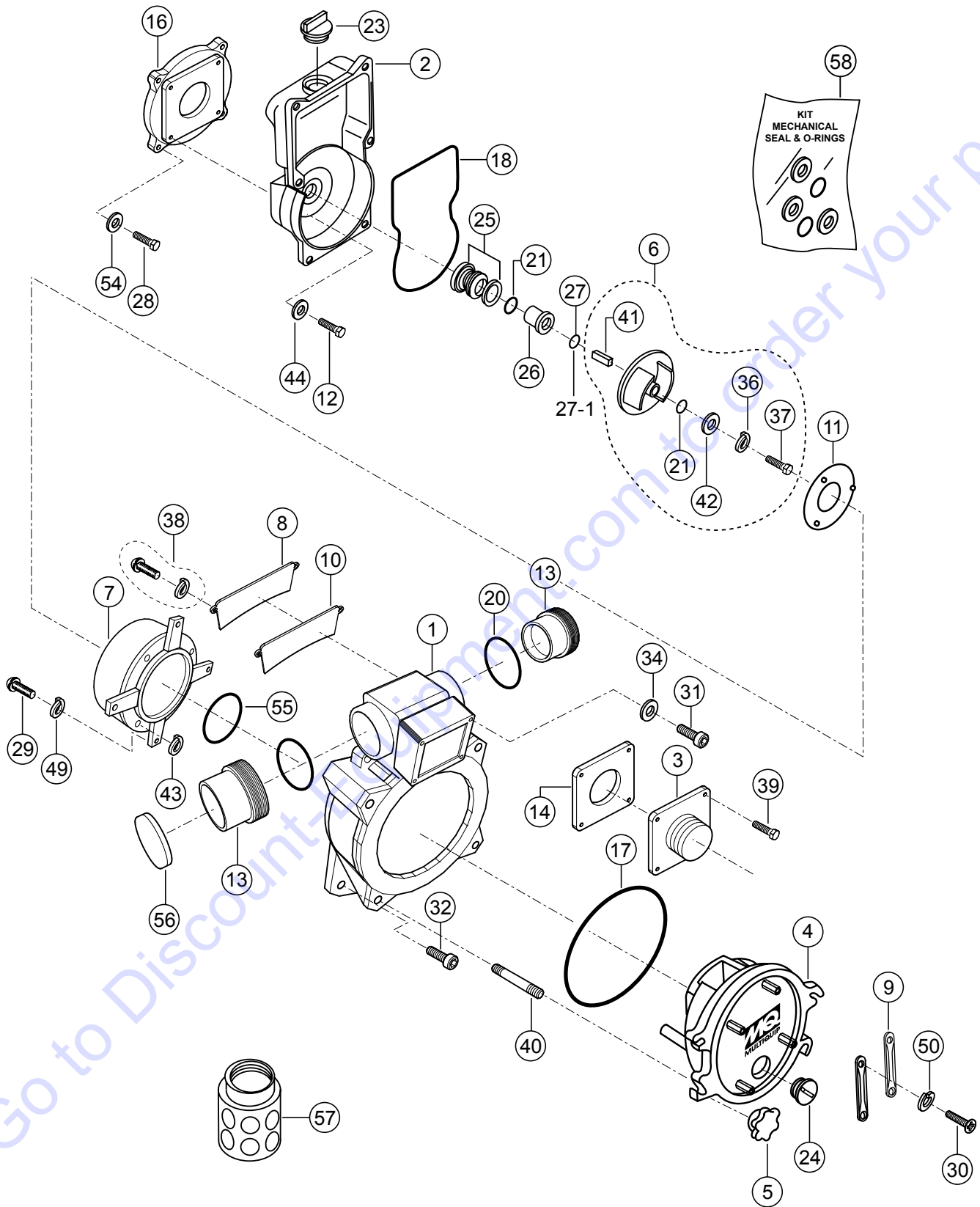

PUMP ASSEMBLY

<u>NO.</u>	<u>PART NO.</u>	<u>PART NAME</u>	<u>QTY.</u>	<u>REMARKS</u>
1	1992100011	CASING	1	
2	1992100020	CASING COVER	1	
3	13910001600014	SUCTION COVER	1	
4	1992100173	DRAIN COVER	1	
5	19920002200014	DRAIN COVER HANDLE	4	
6	1992040033ASSY	IMPELLER ASSY.....	1	REPLACES P/N 1992040033 INCLUDES ITEMS W/#
7	1992000110	VOLUTE CASING	1	
8	1992100742	SUCTION PLATE	1	
9	12471002500002	DRAIN COVER SET HANDLE.....	2	REPLACES P/N 1247100250
10	1992330410	SUCTION PLATE PACKING	1	
11	1992250700	WEAR PLATE	1	
12	2008020	BOLT, CASING COVER.....	4	REPLACES P/N 0105090820
13	07904330300014	NIPPLE, NPS 3X3 NPT	2	
14	1378350350	CHECK VALVE	1	
16	43130006000014	CASING COVER SET PLATE	1	
17@	0483602250	O-RING, DRAIN COVER	1	
18	0489403400	O-RING, CASING	1	
19	0105091020	BOLT	2	
20	0481310800	O-RING, NIPPLE	2	
21#@	0482200240	O-RING	2	
23	0631211159	FLOODING CAP	1	
24	0631211159	DRAIN CAP	1	
25@	0803442930	MECHANICAL SEAL	1	
26@	0811885446	MECHANICAL SEAL SLEEVE	1	
27@	0852834525	ADJUST LINER	1	
27-1@	0852854525	ADJUST LINER	1	
28	0191170625	BOLT, CASING COVER SET PLATE	4	
29	0131190823	CAP SCREW, VOLUTE CASING	4	
30	0141090825	SCREW, DRAIN COVER SET HANDLE	4	
31	0131191290	CAP SCREW, CASING	1	
32	0131191235	CAP SCREW, CASING	4	
34	0459220120	SEAL WASHER, CASING	1	
36#	0458220100	SEAL WASHER, IMPELLER	1	
37#	0191190750	BOLT, IMPELLER	1	

NOTICE

Item 21, O-ring, is included in Impeller Kit, Item 6. When ordered as part of the kit, quantity of -ring is one. Replacement Impeller requires two O-rings, so it is necessary to order one additional O-ring.

PUMP ASSEMBLY (CONTINUED)

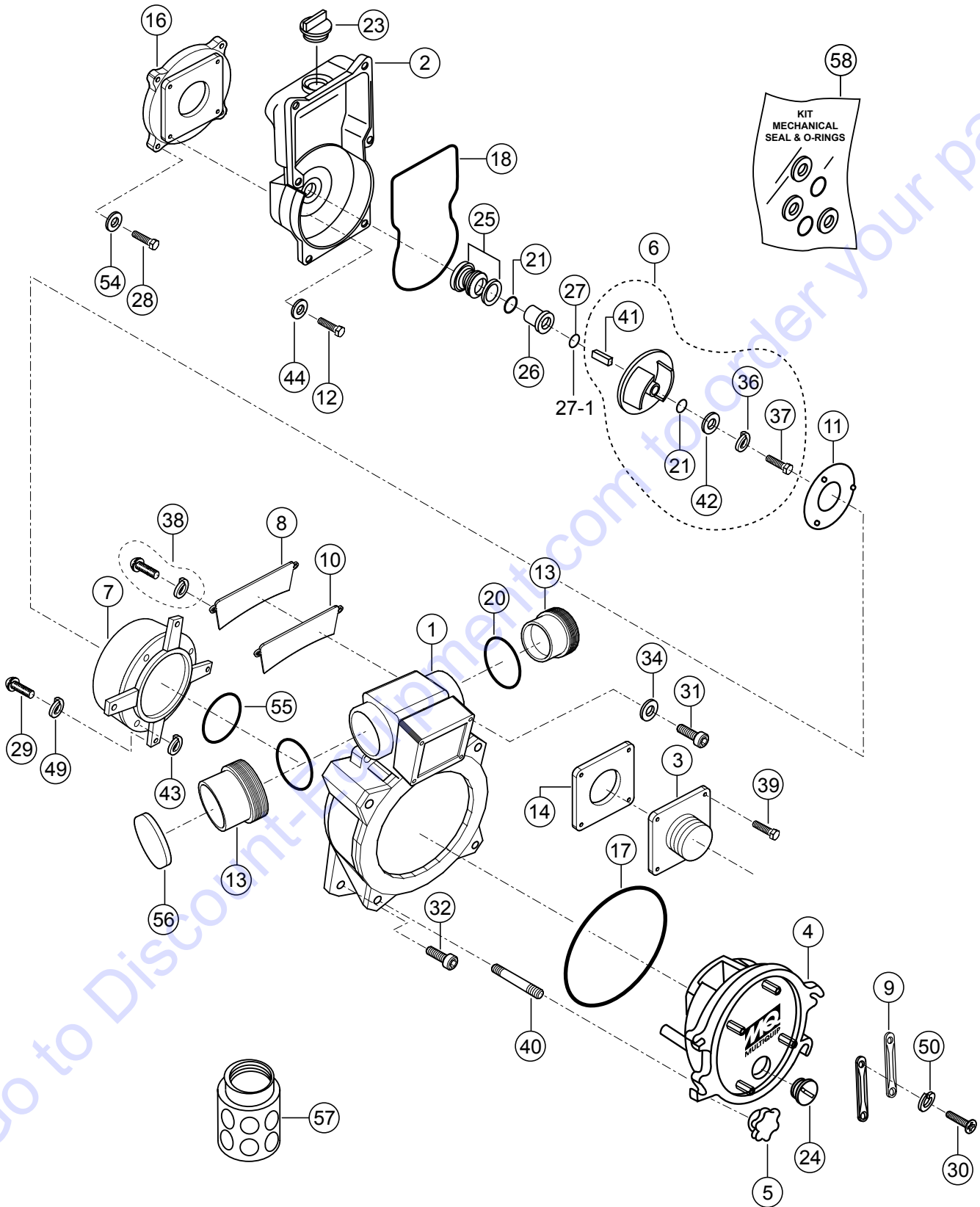

PUMP ASSEMBLY (CONTINUED)

<u>NO.</u>	<u>PART NO.</u>	<u>PART NAME</u>	<u>QTY.</u>	<u>REMARKS</u>
38	0181090820	BOLT SET WITH LOCK WASHER	2	
39	0181090825	BOLT SET WITH LOCK WASHER	4	
40	0151191257	STUD BOLT, DRAIN COVER HANDLE	4	
41#	0520040431	KEY, IMPELLER	1	
42	1466251240	IMPELLER WASHER.....	1.....	REPLACES P/N 43342012400011
43	0204490060	U-NUT, WEAR PLATE	3	
44	0458220080	SEAL WASHER, CASING COVER	4	
49	0451290080	WASHER, LOCK VOLUTE CASING	4	
50	0451290080	WASHER, LOCK SS 20 MM	4	
54	0451250100	WASHER, LOCK.....	4.....	REPLACES P/N 0451290100
55	0480570850	O-RING, VOLUTE CASING	1	
56	1992108050	CAP	1	
57	0742214080	STRAINER	1	
58@	KIT3TE	MECHANICAL SEAL KIT.....	1.....	INCLUDES ITEMS W/@

CONTROL PANEL ASSEMBLY

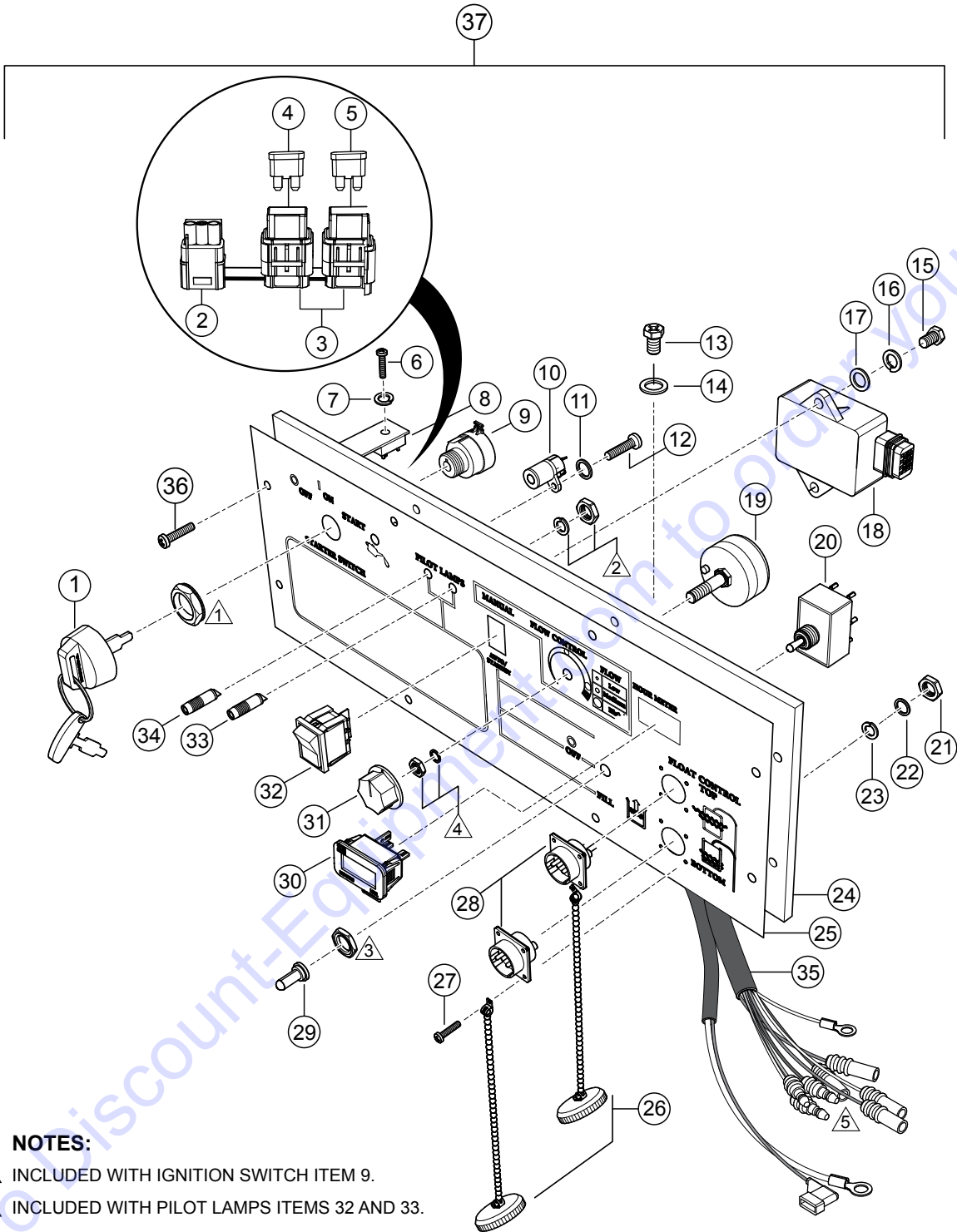

NOTES:

- ① INCLUDED WITH IGNITION SWITCH ITEM 9.
- ② INCLUDED WITH PILOT LAMPS ITEMS 32 AND 33.
- ③ INCLUDED WITH DRAIN/FILL SWITCH ITEM 20.
- ④ INCLUDED WITH FLOW CONTROL POTENTIOMETER ITEM 19.
- ⑤ WIRE HARNESS INCLUDED WITH CONTROL PANEL.

CONTROL PANEL ASSEMBLY

<u>NO.</u>	<u>PART NO.</u>	<u>PART NAME</u>	<u>QTY.</u>	<u>REMARKS</u>
1#	TBD	IGNITION KEYS W/BOOT	2	
2#	TBD	CONNECTOR, 2-PIN, TEST PORT	1	
3#	TBD	FUSE HOLDER	2	
4#	TBD	FUSE, 7.5 AMP	1	
5#	TBD	FUSE, 30 AMP	1	
6#	TBD	SCREW	1	
7#	TBD	WASHER, LOCK	1	
8#	TBD	RECTIFIER	1	
9#	TBD	IGNITION SWITCH	1	
10#	TBD	OIL LAMP/HOLDER	1	
11#	TBD	SCREW	1	
12#	TBD	WASHER, LOCK	1	
13#	TBD	MACHINE SCREW	1	
14#	TBD	WASHER, FLAT	1	
15#	TBD	SCREW	2	
16#	TBD	WASHER, LOCK	2	
17#	TBD	WASHER, FLAT	2	
18#	7308802700	ECU	1	
19#	TBD	POTENTIOMETER	1	
20#	TBD	DRAIN FILL SWITCH	1	
21#	TBD	HEX NUT	8	
22#	TBD	WASHER, FLAT	8	
23#	TBD	WASHER, LOCK	8	
24#	TBD	CONTROL PANEL	1	
25#	TBD	PANEL OVERLAY	1	
26#	TBD	WATER PROOF CAP/WCHAIN	2	
27#	TBD	MACHINE SCREW	8	
29#	7308343200	RUBBER BOOT, SWITCH	1	
30#	TBD	HOUR METER	1	
31#	7308662910	KNOB	1	
32#	TBD	ROCKER SWITCH, AUTO/STANDBY	1	
33#	TBD	PILOT LAMP RED	1	
34#	TBD	PILOT LAMP GREEN	1	
35#	TBD	WIRE HARNESS	1	
36#.	0143090510	TRUSS HEAD SCREW	8	
37	3TIOPTCOPN	CONTROL PANEL ASSY.....	1.....	INCLUDES ITEMS W/#

FLOAT SWITCHES AND UTILITY BOX ASSEMBLY

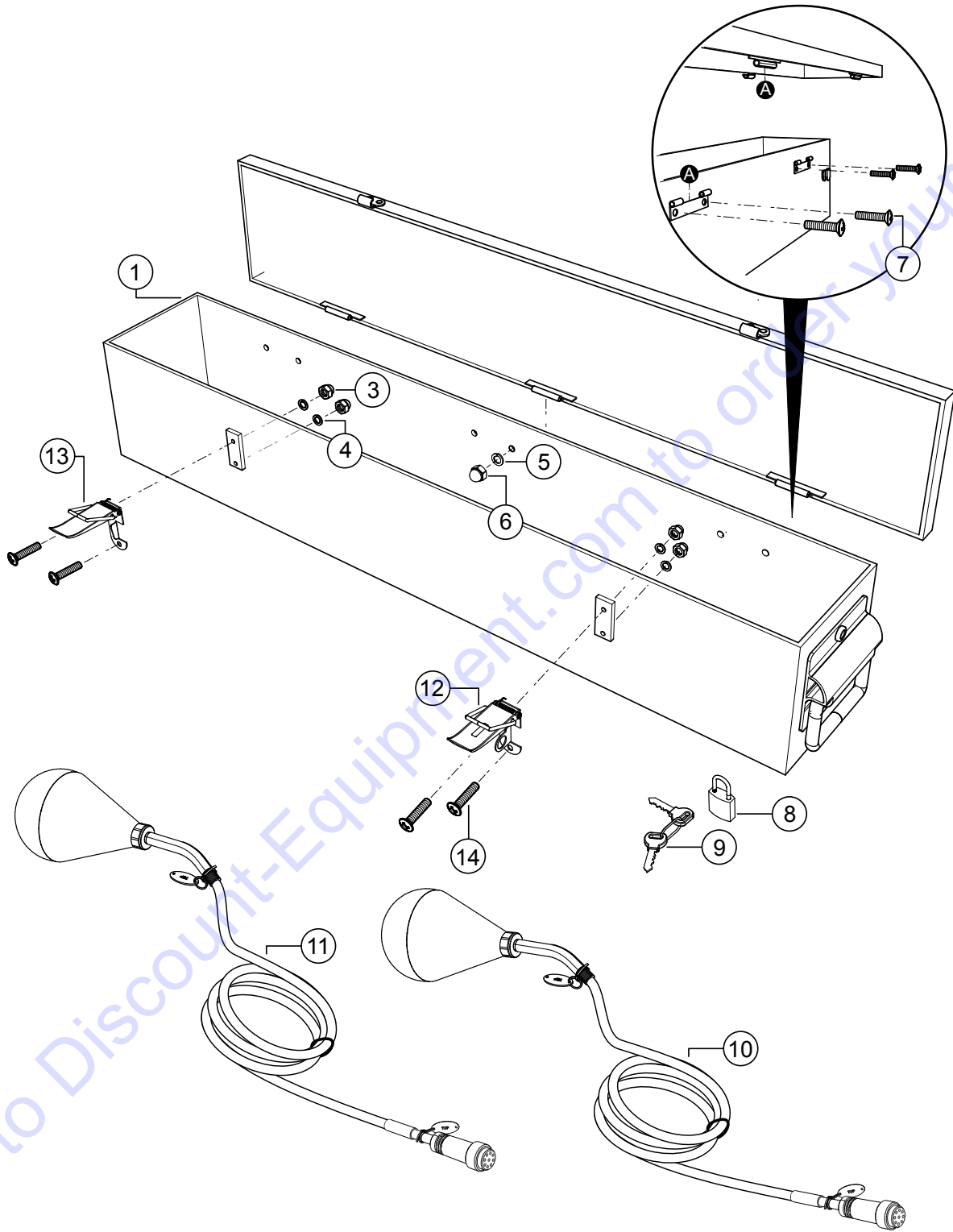

FLOAT SWITCHES AND UTILITY BOX ASSEMBLY

<u>NO.</u>	<u>PART NO.</u>	<u>PART NAME</u>	<u>QTY.</u>	<u>REMARKS</u>
1	QP3BOX	UTILITY BOX, COMPLETE	1.....	OPTION
3	TBD	NUT, ACORN, SMALL	4	
4	TBD	WASHER, FLAT	4	
5	TBD	WASHER, LOCK	6	
6	TBD	NUT, ACORN, LARGE	6	
7	TBD	PAN HEAD SCREW	6	
8	TBD	PAD LOCK	1	
9	TBD	KEYS/LOCK	2	
10	FS43	FLOAT SWITCH, DUAL FLT. ASSY., 43', 13M	1	
11	FS65	FLOAT SWITCH, DUAL FLT. ASSY., 65', 20M	1.....	OPTION
12	TBD	LATCH RIGHT-SIDE	1	
13	TBD	LATCH LEFT-SIDE	1	
14	TBD	PHILLIPS HEAD SCREW	4	

Go to Discount-Equipment.com to order your parts

FRAME AND BATTERY ASSEMBLY

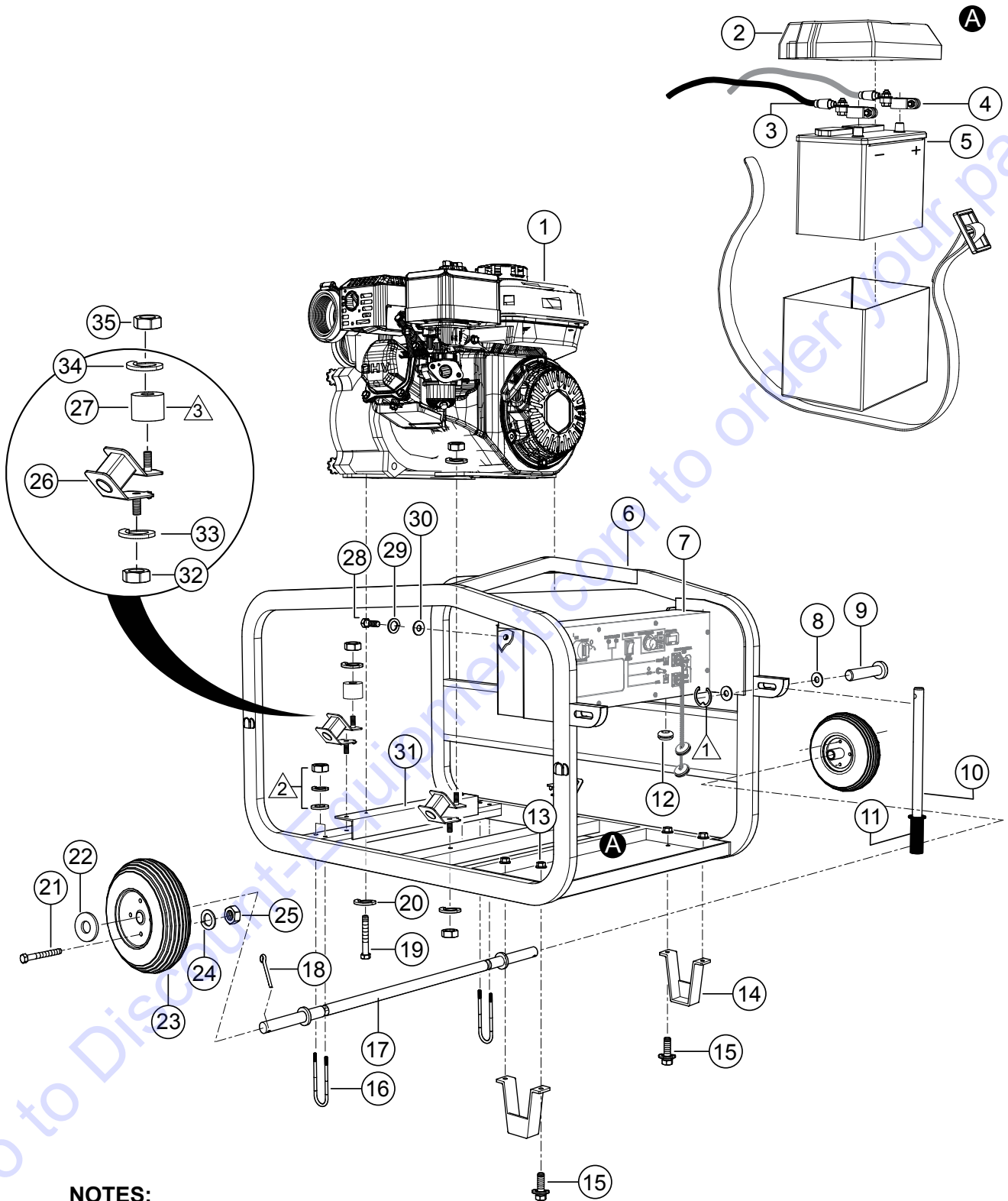

NOTES:

- ① INCLUDED WITH HINGE PIN ITEM# 9.
- ② INCLUDED WITH U-BOLT ITEM 16.
- ③ USE WITH PUMP END ONLY.

FRAME AND BATTERY ASSEMBLY

<u>NO.</u>	<u>PART NO.</u>	<u>PART NAME</u>	<u>QTY.</u>	<u>REMARKS</u>
1	iGX270UT2QZMD	ENGINE	1	
2	7308805200	BATTERY BOX	1	
3	0972159055	BATTERY CABLE (-)	1	
4	0972159075	BATTERY CABLE (+)	1	
5	TBD	BATTERY	1	
6	7308214010P002	BASE, PIPE FRAME	1	
7	TBD	CONTROL BOX, REAR PANEL	1	
8	0401650080	WASHER, FLAT	4	
9	0652500830	HINGE PIN WITH SNAP RING	2	
10	73082148700014	HANDLE	2	
11	0732502211	GRIP, RUBBER	2	
12	7308343000	GROMMET	1	
13	0209190080	FLANGE NUT	4	
14	73082139500014	PUMP STAND	2	
15	2008020	BOLT SET WITH LOCK WASHER.....	4	REPLACES P/N 0105090820
16	0190102057	U-BOLT	2	INCLUDES MTG.HDW
17	73082092300014	AXLE	1	
18	0641400430	COTTER PIN	2	
19	0105091020	BOLT	2	
20	0451250100	WASHER, LOCK.....	6	REPLACES P/N 0451290100
21	TBD	BOLT	8	
22	0401450200	WASHER, 20 MM	2	
23	0982601906	TIRE	2	
24	TBD	WASHER, LOCK	8	
25	TBD	NUT	8	
26	0725223229	CUSHION RUBBER, SLANT MOUNT	4	
27	73082246500014	CUSHION RUBBER SPACER	2	
28	0105090612	BOLT	4	
29	0451290060	WASHER, LOCK	4	
30	0401650060	WASHER, FLAT	4	
31	73082445500014	CUSHION RUBBER STAY	1	
32	0205490080	NUT	4	
33	0451290080	WASHER, LOCK 8MM	4	
34	0451290100	WASHER, LOCK	4	
35	0205490101	NUT	4	

HONDA iGX270UT2QZMD ENGINE SERVICE PARTS

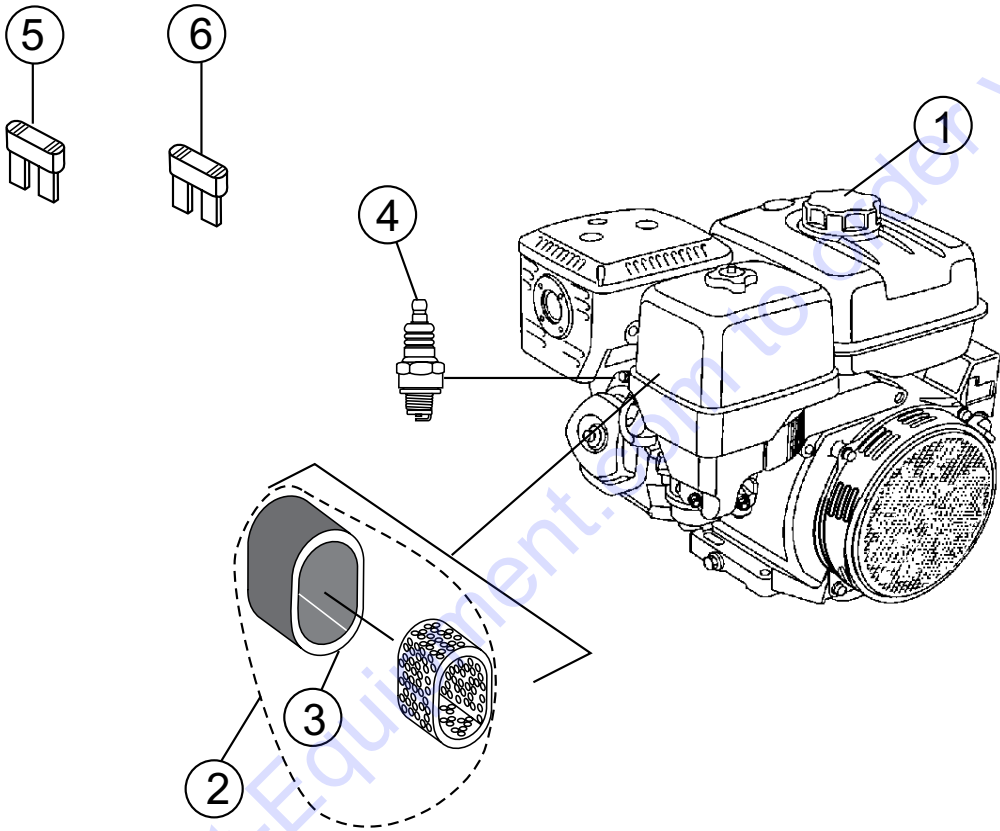

HONDA iGX270UT2QZMD ENGINE SERVICE PARTS

<u>NO.</u>	<u>PART NO.</u>	<u>PART NAME</u>	<u>QTY.</u>	<u>REMARKS</u>
1	17620Z4H900	CAP COMP., FUEL TANK	1	
2	17210Z5KW00	ELEMENT COMP., AIR CLEANER.....	1	INCLUDES ITEM W/ #
3#	17218ZE2505	FILTER, OUTER	1	
4	9807955846	SPARK PLUG (BPR5ES)	1	
5	9820040750	FUSE, MINI 7.5A	1	
6	9820043000	FUSE, MINI 30A	1	

Go to Discount-Equipment.com to order your parts

PARTS FINDER

**Search Website
by Part Number**



**Search Manual
Library For Parts
Manual & Lookup Part
Numbers – Purchase
or Request Quote**

Search Manuals

Enter your information to help us find the right parts manual for your machine.

* Brand:

* Model:

* Serial:

* Part Number:

SEARCH

**Can't Find Part or
Manual? Request Help
by Manufacturer,
Model & Description**

Parts Order Form

Please fill in the following information to help us find the right part for your machine.

Manufacturer:	<input type="text"/>
Model:	<input type="text"/>
Description:	<input type="text"/>
Part Number:	<input type="text"/>
Quantity:	<input type="text"/>
Notes:	<input type="text"/>

Discount-Equipment.com is your online resource for quality parts & equipment.

Florida: **561-964-4949** Outside Florida TOLL FREE: **877-690-3101**

Need parts?

Click on this link: <http://www.discount-equipment.com/category/5443-parts/> and choose one of the options to help get the right parts and equipment you are looking for. Please have the machine model and serial number available in order to help us get you the correct parts. If you don't find the part on the website or on one of the online manuals, please fill out the request form and one of our experienced staff members will get back to you with a quote for the right part that your machine needs.

We sell worldwide for the brands: Genie, Terex, JLG, MultiQuip, Mikasa, Essick, Whiteman, Mayco, Toro Stone, Diamond Products, Generac Magnum, Airman, Haulotte, Barreto, Power Blanket, Nifty Lift, Atlas Copco, Chicago Pneumatic, Allmand, Miller Curber, Skyjack, Lull, Skytrak, Tsurumi, Husquvarna Target, Stow, Wacker, Sakai, Mi-T-M, Sullair, Basic, Dynapac, MBW, Weber, Bartell, Bennar Newman, Haulotte, Ditch Runner, Menegotti, Morrison, Contec, Buddy, Crown, Edco, Wyco, Bomag, Laymor, EZ Trench, Bil-Jax, F.S. Curtis, Gehl Pavers, Heli, Honda, ICS/PowerGrit, IHI, Partner, Imer, Clipper, MMD, Koshin, Rice, CH&E, General Equipment, Amida, Coleman, NAC, Gradall, Square Shooter, Kent, Stanley, Tamco, Toku, Hatz, Kohler, Robin, Wisconsin, Northrock, Oztec, Toker TK, Rol-Air, APT, Wylie, Ingersoll Rand / Doosan, Innovatech, Con X, Ammann, Mecalac, Makinex, Smith Surface Prep, Small Line, Wanco, Yanmar