

PARTS MANUAL



MODEL QP15HP HIGH PRESSURE CENTRIFUGAL PUMP (HONDA GXH50UWKE4 GASOLINE ENGINE)

Revision #3 (06/03/20)



THIS MANUAL MUST ACCOMPANY THE EQUIPMENT AT ALL TIMES.

PARTS FINDER

**Search Website
by Part Number**



**Search Manual
Library For Parts
Manual & Lookup Part
Numbers – Purchase
or Request Quote**

Search Manuals

Enter your information to help us find the right parts manual for your machine.

* Brand:

* Model:

* Serial:

* Part Number:

SEARCH

**Can't Find Part or
Manual? Request Help
by Manufacturer,
Model & Description**

Parts Order Form

Please fill in the following information to help us find the right part for your machine.

MANUFACTURER:

MODEL:

DESCRIPTION:

SEARCH

Discount-Equipment.com is your online resource for quality parts & equipment.

Florida: **561-964-4949** Outside Florida TOLL FREE: **877-690-3101**

Need parts?

Click on this link: <http://www.discount-equipment.com/category/5443-parts/> and choose one of the options to help get the right parts and equipment you are looking for. Please have the machine model and serial number available in order to help us get you the correct parts. If you don't find the part on the website or on one of the online manuals, please fill out the request form and one of our experienced staff members will get back to you with a quote for the right part that your machine needs.

We sell worldwide for the brands: Genie, Terex, JLG, MultiQuip, Mikasa, Essick, Whiteman, Mayco, Toro Stone, Diamond Products, Generac Magnum, Airman, Haulotte, Barreto, Power Blanket, Nifty Lift, Atlas Copco, Chicago Pneumatic, Allmand, Miller Curber, Skyjack, Lull, Skytrak, Tsurumi, Husquvarna Target, Stow, Wacker, Sakai, Mi-T-M, Sullair, Basic, Dynapac, MBW, Weber, Bartell, Bennar Newman, Haulotte, Ditch Runner, Menegotti, Morrison, Contec, Buddy, Crown, Edco, Wyco, Bomag, Laymor, EZ Trench, Bil-Jax, F.S. Curtis, Gehl Pavers, Heli, Honda, ICS/PowerGrit, IHI, Partner, Imer, Clipper, MMD, Koshin, Rice, CH&E, General Equipment, Amida, Coleman, NAC, Gradall, Square Shooter, Kent, Stanley, Tamco, Toku, Hatz, Kohler, Robin, Wisconsin, Northrock, Oztec, Toker TK, Rol-Air, APT, Wylie, Ingersoll Rand / Doosan, Innovatech, Con X, Ammann, Mecalac, Makinex, Smith Surface Prep, Small Line, Wanco, Yanmar

QP15HP Centrifugal Pump

Explanation of Code in Remarks Column..... 4
Suggested Spare Parts 5

Component Drawings

Pump Assembly..... 6-7
Engine Mounting Assembly..... 8-9
Engine Service Parts..... 10-11

NOTICE

Specifications and part numbers are subject to change without notice.

Go to Discount-Equipment.com to order your parts

EXPLANATION OF CODE IN REMARKS COLUMN

The following section explains the different symbols and remarks used in the Parts section of this manual. Use the help numbers found on the back page of the manual if there are any questions.

NOTICE

The contents and part numbers listed in the parts section are subject to change **without notice**. Multiquip does not guarantee the availability of the parts listed.

SAMPLE PARTS LIST

NO.	PART NO.	PART NAME	QTY.	REMARKS
1	12345	BOLT	1	INCLUDES ITEMS W/%
2%		WASHER, 1/4 IN.		NOT SOLD SEPARATELY
2%	12347	WASHER, 3/8 IN. ...	1	MQ-45T ONLY
3	12348	HOSE	A/R	MAKE LOCALLY
4	12349	BEARING	1	S/N 2345B AND ABOVE

NO. Column

Unique Symbols — All items with same unique symbol (@, #, +, %, or >) in the number column belong to the same assembly or kit, which is indicated by a note in the “Remarks” column.

Duplicate Item Numbers — Duplicate numbers indicate multiple part numbers, which are in effect for the same general item, such as different size saw blade guards in use or a part that has been updated on newer versions of the same machine.

NOTICE

When ordering a part that has more than one item number listed, check the remarks column for help in determining the proper part to order.

PART NO. Column

Numbers Used — Part numbers can be indicated by a number, a blank entry, or TBD.

TBD (To Be Determined) is generally used to show a part that has not been assigned a formal part number at the time of publication.

A blank entry generally indicates that the item is not sold separately or is not sold by Multiquip. Other entries will be clarified in the “Remarks” Column.

QTY. Column

Numbers Used — Item quantity can be indicated by a number, a blank entry, or A/R.

A/R (As Required) is generally used for hoses or other parts that are sold in bulk and cut to length.

A blank entry generally indicates that the item is not sold separately. Other entries will be clarified in the “Remarks” Column.

REMARKS Column

Some of the most common notes found in the “Remarks” Column are listed below. Other additional notes needed to describe the item can also be shown.

Assembly/Kit — All items on the parts list with the same unique symbol will be included when this item is purchased.

Indicated by:

“INCLUDES ITEMS W/(unique symbol)”

Serial Number Break — Used to list an effective serial number range where a particular part is used.

Indicated by:

“S/N XXXXX AND BELOW”

“S/N XXXX AND ABOVE”

“S/N XXXX TO S/N XXX”

Specific Model Number Use — Indicates that the part is used only with the specific model number or model number variant listed. It can also be used to show a part is NOT used on a specific model or model number variant.

Indicated by:

“XXXXX ONLY”

“NOT USED ON XXXX”

“Make/Obtain Locally” — Indicates that the part can be purchased at any hardware shop or made out of available items. Examples include battery cables, shims, and certain washers and nuts.

“Not Sold Separately” — Indicates that an item cannot be purchased as a separate item and is either part of an assembly/kit that can be purchased, or is not available for sale through Multiquip.

SUGGESTED SPARE PARTS

QP15HP HIGH PRESSURE CENTRIFUGAL PUMP

1 to 3 units

Qty.	P/N	Description
2	0806112515	MECHANICAL SEAL
2	0852831812	ADJUST LINER
2	0852851812	ADJUST LINER
1	1129100030	IMPELLER
2	0631211060	FLOODING CAP

NOTICE

Part numbers on this Suggested Spare Parts list may supersede/replace the part numbers shown in the following parts lists.

HONDA GXH50UWKE4 GASOLINE ENGINE

1 to 3 units

Qty.	P/N	Description
2	17211ZM7000	ELEMENT, AIR
3	9805655777	SPARK PLUG (NKG)
3	28462ZM70003	ROPE, STARTER
1	17620ZL8023	CAP, FUEL
1	28461ZM3003	KNOB, RECOIL STARTER
1	35480ZM7801	OIL LEVEL SWITCH

PUMP ASSEMBLY

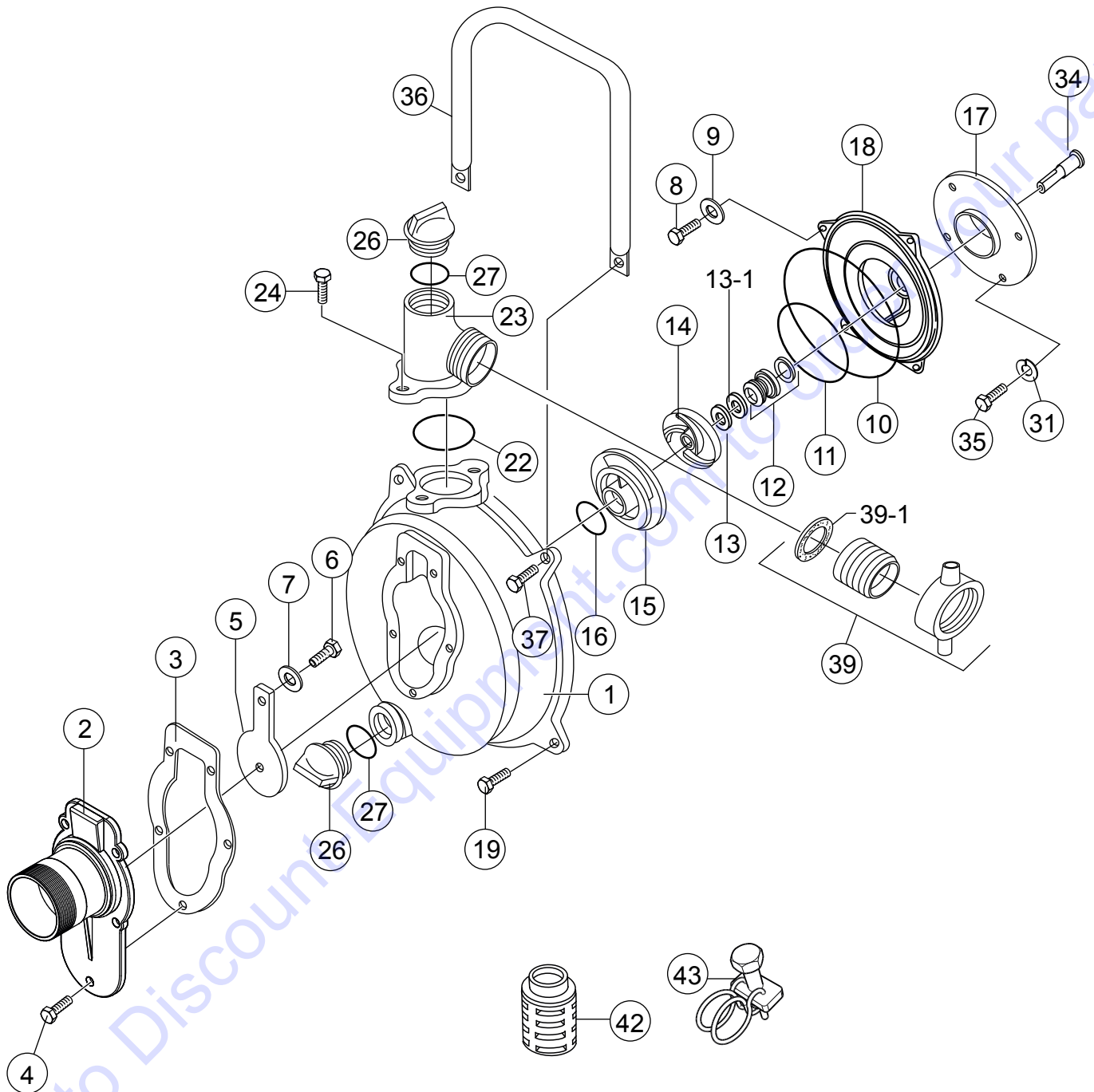

PUMP ASSEMBLY

<u>NO.</u>	<u>PART NO.</u>	<u>PART NAME</u>	<u>QTY.</u>	<u>REMARKS</u>
1	1714100010	CASING	1	
2	1749100160	SUCTION COVER	1	
3	1714330370	SUCTION COVER PACKING	1	
4	0141050512	SCREW	5	
5	1701350350	CHECK VALVE	1	
6	0141090510	SCREW	1	
7	0401450050	WASHER	1	
8	0105050620	BOLT	4	
9	0458220060	SEAL WASHER	4	
10	0489311810	O-RING	1	
11	0489241380	O-RING	1	
12	0806112515	MECHANICAL SEAL	1	
13	0852831812	ADJUST LINER	1	
13-1	0852851812	ADJUST LINER	1	
14	1129100030	IMPELLER	1	
15	1714100130	VOLUTE CASING	1	
16	0482200380	O-RING	1	
17	1129060600	CASING COVER SET PLATE	1	
18	1714100021	CASING COVER	1	
19	0181051025	BOLT SET WITH LOCK WASHER	2	
22	0480350440	O-RING	1	
23	1749100090	DELIVERY ELBOW	1	
24	0181050820	BOLT SET WITH LOCK WASHER	2	
26	0631211060	FLOODING/DRAIN CAP	2	
27	0481310250	FLOODING/DRAIN CAP O-RING	2	
31	0451250060	LOCK WASHER	4	
34	1129221010	PUMP SHAFT	1	
35	0141050620	SCREW	4	
36	17462070100014	HANDLE	1	
37	0181051030	BOLT SET WITH LOCK WASHER	2	
39	0741158040	HOSE COUPLING SET	2	INCLUDES ITEM W/#
39-1#	0744310401	HOSE COUPLING PACKING	2	
42	0742214040	STRAINER	1	
43	0932251120	WIRE HOSE BAND	3	

ENGINE MOUNTING ASSY.

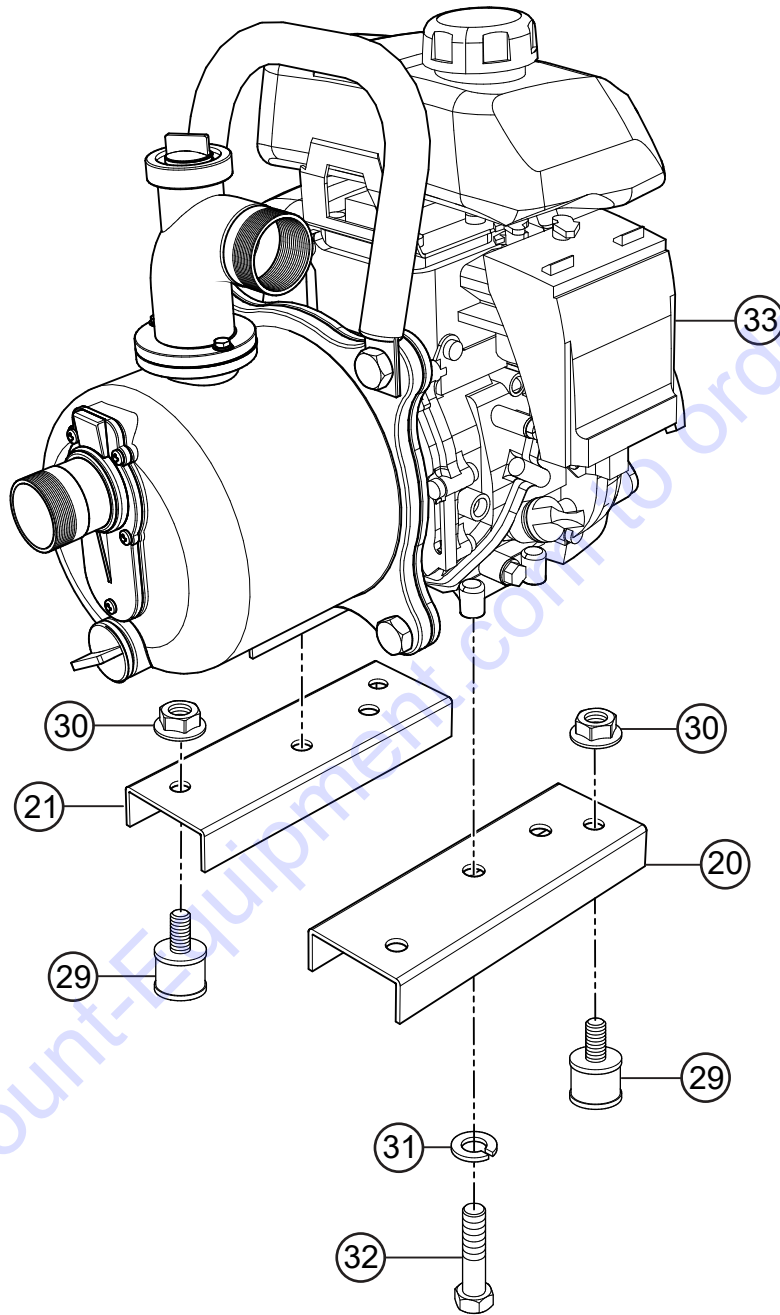

ENGINE MOUNTING ASSY.

<u>NO.</u>	<u>PART NO.</u>	<u>PART NAME</u>	<u>QTY.</u>	<u>REMARKS</u>
20	17492040100014	BASE, RIGHT	1	
21	17492042600014	BASE, LEFT	1	
29	0723322030R	CUSHION RUBBER	4	
30	0209150060	FLANGE NUT	4	
31	0451250060	WASHER, LOCK	4	
32	0105050616	BOLT	4	
33	GXH50UWKE4	ENGINE, GASOLINE 2.1 HP	1	

Go to Discount-Equipment.com to order your parts

ENGINE SERVICE PARTS

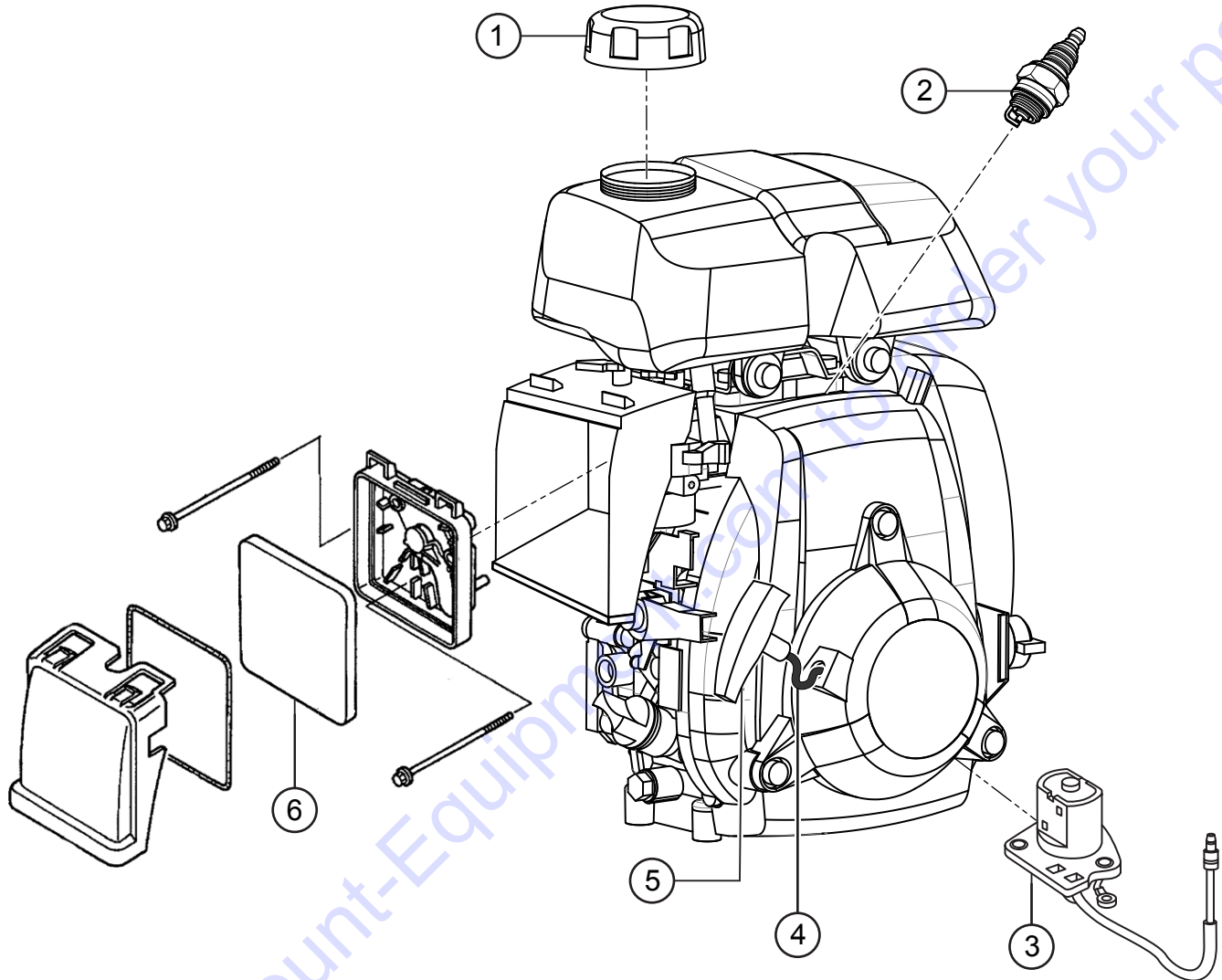

ENGINE SERVICE PARTS

<u>NO.</u>	<u>PART NO.</u>	<u>PART NAME</u>	<u>QTY.</u>	<u>REMARKS</u>
1	17620ZL8023	CAP, FUEL	1	
2	9805655777	SPARK PLUG (NKG)	1	
3	35480ZM7801	OIL LEVEL SWITCH ASSY.	1	
4	28462ZM70003	ROPE, STARTER	1	
5	28461ZM3003	KNOB, RECOIL STARTER	1	
6	17211ZM7000	ELEMENT, AIR	1	

Go to Discount-Equipment.com to order your parts

PARTS FINDER

**Search Website
by Part Number**



**Search Manual
Library For Parts
Manual & Lookup Part
Numbers – Purchase
or Request Quote**

Search Manuals

Enter your information to help us find the right parts manual for your machine.

* Brand:

* Model:

* Serial:

* Part Number:

SEARCH

**Can't Find Part or
Manual? Request Help
by Manufacturer,
Model & Description**

Parts Order Form

Please fill in the following information to help us find the right part for your machine.

Manufacturer:	<input type="text"/>
Model:	<input type="text"/>
Description:	<input type="text"/>
Part Number:	<input type="text"/>
Quantity:	<input type="text"/>
Notes:	<input type="text"/>

Submit

Discount-Equipment.com is your online resource for quality parts & equipment.

Florida: **561-964-4949** Outside Florida TOLL FREE: **877-690-3101**

Need parts?

Click on this link: <http://www.discount-equipment.com/category/5443-parts/> and choose one of the options to help get the right parts and equipment you are looking for. Please have the machine model and serial number available in order to help us get you the correct parts. If you don't find the part on the website or on one of the online manuals, please fill out the request form and one of our experienced staff members will get back to you with a quote for the right part that your machine needs.

We sell worldwide for the brands: Genie, Terex, JLG, MultiQuip, Mikasa, Essick, Whiteman, Mayco, Toro Stone, Diamond Products, Generac Magnum, Airman, Haulotte, Barreto, Power Blanket, Nifty Lift, Atlas Copco, Chicago Pneumatic, Allmand, Miller Curber, Skyjack, Lull, Skytrak, Tsurumi, Husquvarna Target, Stow, Wacker, Sakai, Mi-T-M, Sullair, Basic, Dynapac, MBW, Weber, Bartell, Bennar Newman, Haulotte, Ditch Runner, Menegotti, Morrison, Contec, Buddy, Crown, Edco, Wyco, Bomag, Laymor, EZ Trench, Bil-Jax, F.S. Curtis, Gehl Pavers, Heli, Honda, ICS/PowerGrit, IHI, Partner, Imer, Clipper, MMD, Koshin, Rice, CH&E, General Equipment, Amida, Coleman, NAC, Gradall, Square Shooter, Kent, Stanley, Tamco, Toku, Hatz, Kohler, Robin, Wisconsin, Northrock, Oztec, Toker TK, Rol-Air, APT, Wylie, Ingersoll Rand / Doosan, Innovatech, Con X, Ammann, Mecalac, Makinex, Smith Surface Prep, Small Line, Wanco, Yanmar